



THE DATASHEET OF UT1201-7G





MELCHER™
The Power Partners.

T Series

500 W AC-DC Converters

FEATURES

- RoHS lead-free-solder and lead-solder-exempted products available
- Universal AC input range 70 to 255 VAC with PFC
- Class I equipment
- DC output for 24 and 48 V loads
- Battery charging for 24 and 48 V batteries with remote temperature control
- 4 kVAC I/O electric strength test voltage
- Telecom rectifier applications
- Very high efficiency, typically 93%
- Power factor >0.96, low RFI
- Harmonics according to IEC/EN 61000-3-2
- No inrush current, hot swap capability
- High power density, rugged mechanical design, all boards covered with a protective lacquer
- Very compact 19" cassette (28 TE, 3 U, 160 mm)
- Safety-approved to the latest edition of IEC/EN 62368-1 and UL/CSA 60950-1

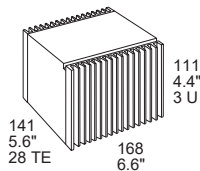

Table of Contents

Description.....	2
Model Selection.....	2
Functional Description.....	4
Electrical Input Data.....	5
Electrical Output Data.....	8
Control Features of the Battery Chargers.....	14
Auxiliary Functions.....	14

Different Configurations and Applications.....	22
Electromagnetic Compatibility (EMC).....	26
Environmental Conditions.....	27
Mechanical Data.....	29
Safety and Installation Instructions.....	31
Description of Options.....	34
Accessories.....	35



DESCRIPTION

The T Series converters are electrically isolated AC-DC converters with an output power of up to 550 W. For higher power requirements several converters may be connected in parallel.

The input is ideally adapted to the mains: Full power factor correction, no inrush current, low RFI level, and high transient and surge immunity are key design features. A T Series converter behaves similar to a resistive load.

The LT models can be operated from a universal AC-input range from 85 to 255 VAC. It is the preferred type for 230 VAC mains, whereas the UT models are optimized for 110/120 VAC mains. The output delivers an electrically isolated energy source class 1 (ES1) and is short-circuit and no-load proof. Depending on the type, two output characteristics are available, intended either for rectifier applications or for battery charging purposes.

The latter types can be integrated into systems, where the output voltage is backed-up by a battery. The float charge of the battery can be set by a cell-voltage selector switch according to the battery type used. These converters are equipped with a temperature sensor input, in order to improve the life expectancy of the battery.

The rectifier models are suited for DC-bus applications at constant voltage. As the output voltage is ES1, even electrically non-isolated switching regulators, such as the PSx models, may be connected to the output.

The LT/UT1701 models are especially optimized to build distributed power systems together with the 48Q, CQ, or CP Series DC-DC converters, as the signaling capabilities of both families are matched. Distributed power systems have as one advantage less power losses over load lines and fewer regulation problems.

Bel Power Solutions also offers backplanes for fast and simple set-up of 19" DIN-rack systems with T Series converters; see *Accessories*.

MODEL SELECTION

Table 1: Model types LT and UT.

Output voltage $V_{o\ set}$ at $V_{i\ nom}^7$ 0.5 $I_{o\ nom}$ [VDC]	Output current $I_{o\ nom}$ [A]	Operating input voltage range and efficiency				Options
		$V_{i\ min} - V_{i\ max}$ 70 - 140 VAC	η_{min}^1 [%]	$V_{i\ min} - V_{i\ max}$ 85 - 255 VAC	η_{min}^1 [%]	
24.25	16	UT1201-7G ^{2,4}	91	LT1201-7G ^{2,6}	90.5	D B1 non-G
25.25 – (27.25) – 28.25	14.5	UT1240-7ZG ^{3,4}	91	LT1240-7ZG ^{3,6}	90	
30.5	15.2	UT1404-7G ^{2,5}	90	–	–	
45.5	9.5	–	–	LT1804-7G ⁶	91.5	
48	11	–	–	LT1702-7G ⁶	92.5	
54.5	10	UT1701-7G ⁵	92	LT1701-7G ⁶	92.5	
50.5 – (54.5) – 56.5	10	UT1740-7ZG ^{3,5}	92	LT1740-7ZG ^{3,6}	92	

¹ Min. efficiency measured at $V_{i\ nom}$ and $I_{o\ nom}$; typ. values are approx. 1% better.

² Instead of output power limitation, output current limitation.

³ Output voltage range controlled by input V_{cr} , remote temperature sensor, and cell voltage selector switch.

⁴ Reduced output power for $V_i = 70 - 95$ VAC; see *Output Power Limitation*.

⁵ Reduced output power for $V_i = 70 - 100$ VAC; see *Output Power Limitation*.

⁶ Reduced output power for $V_i = 85 - 155$ VAC; see *Output Power Limitation*.

NFND: Not for new designs

Preferred for new designs



Part Number Description

LT1740-7DZB1G

Operating input range V_i, f_i	
70 – 140 VAC, 47 – 63 Hz.....	U
85 – 255 VAC, 47 – 63 Hz	L
Series	T
Number of outputs	1
Output setting voltage $V_{o\ set}$	
24, 27.25 V.....	2
48, 54.5 V.....	7
Rectifier version	01, 02 ³
Battery charger version.....	40 ⁴
Other voltages.....	00 to 99
Ambient temperature range T_A	
–25 to 71 °C.....	-7
Customer-specific models.....	-0 to -6
Auxiliary functions and options ¹	
Undervoltage monitor (option).....	D
Cell voltage selector switch.....	Z ²
Baseplate (option).....	B1
RoHS compliant for all six substances.....	G

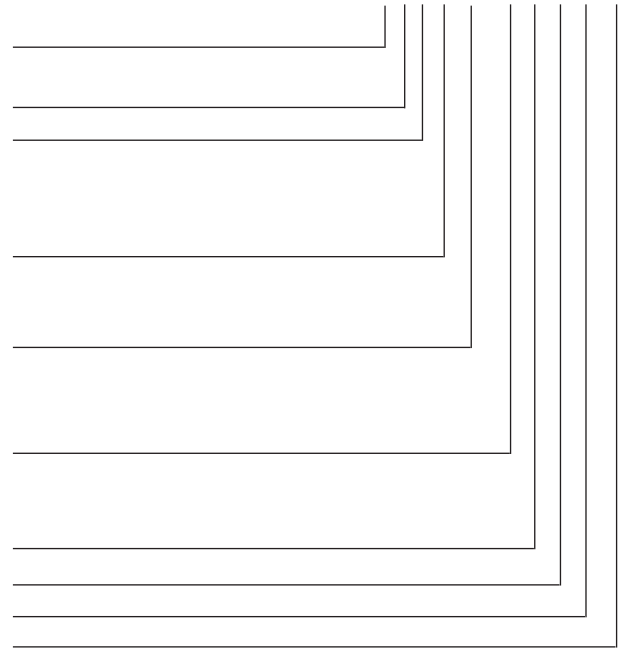

¹ See *Description of Options*. Contact the factory for availability and lead times

² Only for T1240/1740

³ No input for battery temperature sensor

⁴ With input for battery temperature sensor

Note: The sequence of options must follow the order above.

Example: LT1740-7ZG: AC-DC converter, input voltage range 85 – 255VAC, single output 50.5 – 56.5V, 10 A, operational ambient temperature –25 to 71 °C, with cell voltage selector switch, RoHS-compliant for all six substances.

Product Marking

Basic type designation, applicable approval marks, CE mark, warnings, pin designation, Company logo, type designation, nominal input voltage range, nominal output voltage and current, degree of protection, batch no., serial no., and data code including production site, version, and date of production.



FUNCTIONAL DESCRIPTION

The T Series AC-DC converters are primary controlled with a constant switching frequency of 65.5 kHz. The power factor corrected single step conversion of the line input voltage to a low output voltage results in extremely high efficiency.

The input voltage is fed via input fuse, filter, and rectifier to the main transformer. The wideband input filter with small input capacitance generates virtually no inrush current. Transient suppressors protect the converter against overvoltage and surges. An auxiliary converter generates an internal supply voltage for the primary control logic. The input voltage waveform is sensed by the primary control logic to provide active power factor correction.

The main transformer is connected to a rectifier, large output capacitors, and an efficient output filter, which ensures low output ripple and spikes, and provides the necessary hold-up time. The output voltage is fed back to the primary control logic via a signal transformer.

The inhibit signal and the T failure signal are transferred by a second signal transformer (no optocouplers are used!).

System Good and Output OK are each indicated by a green LED; inhibit and T System Failure by a red LED.

System Good and Power Down are available as open collector signals at the connector. The threshold level of the Power Down signal can be externally adjusted at the D set input.

Test sockets at the front panel allow for the measurement of the output voltage.

The battery charger version provides additional features to control the output voltage. To set it to different battery float-charge voltages, a 16-step selector switch (Z) is standard.

A control input to control the output voltage by an external temperature sensor is available at a control pin. A trim-potentiometer allows fine adjustment of the output voltage.

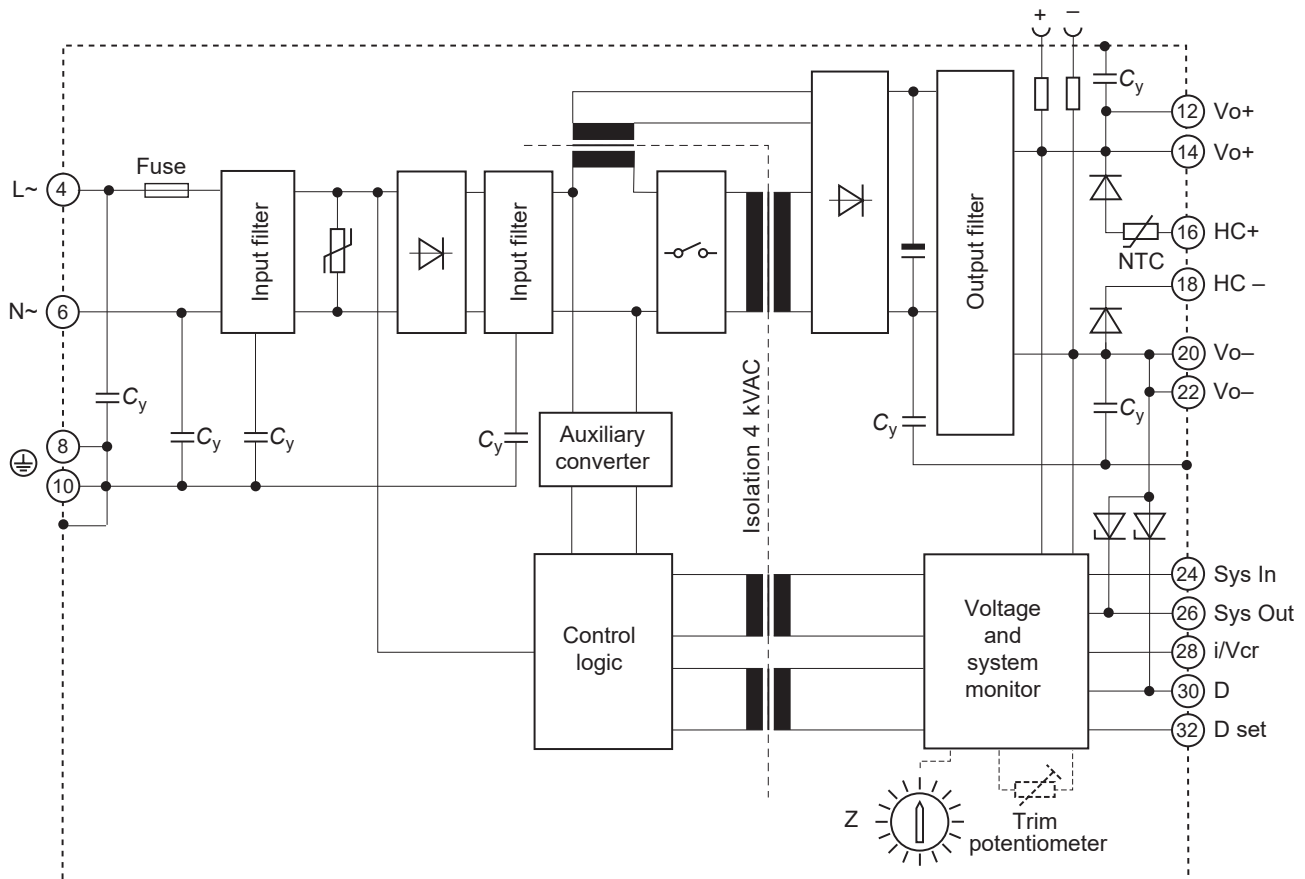

Fig. 1
Block diagram (version V105)

ELECTRICAL INPUT DATA

General condition: $T_A = 20\text{ °C}$, unless specified.

Table 2a: Input data of LT models

Model			LT12xx			LT17xx			LT1804			Unit
Characteristics		Conditions	min	typ	max	min	typ	max	min	typ	max	
V_i	Operating input voltage range with full output power	47 - 63 Hz ²	155		255	155		255	155		255	VAC
$V_{i\text{red}}$	Operating input voltage range with reduced output power ¹		85		155	85		155	85		155	
$V_i(V_{i\text{nom}})$	Rated (nominal) input voltage	50 - 60 Hz ²	100	(230)	240	100	(230)	240	100	(230)	240	
$I_{i\text{nom}}$	Nominal input current	$V_{i\text{nom}}, I_{o\text{nom}}$		1.9			2.6			2.2		A
I_{iL}	Input current limit			3			4			3.4		
P_{i0}	No-load input power	$V_{i\text{min}} - V_{i\text{max}}, I_o = 0$		6			8			8		W
$P_{i\text{inh}}$	Input power when inhibited	$V_{i\text{min}} - V_{i\text{max}}$ inhibit = low		3			3			3		
PF	Power factor	$V_{i\text{nom}}, I_{o\text{nom}}$	96			98			98			%
C_i	Input capacitance ³			4			4			4		μF
t_{on}	Switch on delay	$V_{i\text{nom}}, I_{o\text{nom}}$		400			400			400		ms
	Conducted emissions	$V_{i\text{nom}}, V_{o\text{nom}}, I_{o\text{nom}}$ EN 55032		A			A			A		
	Radiated emissions			A			A			A		
V_{iP}	Input overvoltage protection ⁴			264			264			264		VAC
V_{iL}	Input undervoltage lockout			65			65			65		

Table 2b: Input data of UT models

Model			UT12xx			UT17xx			Unit
Characteristics		Conditions	min	typ	max	min	typ	max	
V_i	Operating input voltage range with full output power	47 - 63 Hz ²	95		140	100		140	VAC
$V_{i\text{red}}$	Operating input voltage range with reduced output power ¹		70		95	70		100	
$V_i(V_{i\text{nom}})$	Rated (nominal) input voltage	50 - 60 Hz ²	100	(110)	125	100	(110)	125	
$I_{i\text{nom}}$	Nominal input current	$V_{i\text{nom}}, I_{o\text{nom}}$		3.8			5.2		A
I_{iL}	Input current limit			5			6		
P_{i0}	No-load input power	$V_{i\text{min}} - V_{i\text{max}}, I_o = 0$		6			8		W
$P_{i\text{inh}}$	Input power when inhibited	$V_{i\text{min}} - V_{i\text{max}}$ inhibit = low		3			3		
PF	Power factor	$V_{i\text{nom}}, I_{o\text{nom}}$	98			98			%
C_i	Input capacitance ³			4			4		μF
t_{on}	Switch on delay	$V_{i\text{nom}}, I_{o\text{nom}}$		400			400		ms
	Conducted emissions	$V_{i\text{nom}}, V_{o\text{nom}}, I_{o\text{nom}}$ EN 55032		A			A		
	Radiated emissions			A			A		
V_{iP}	Input overvoltage protection ⁴			165			165		VAC
V_{iL}	Input undervoltage lockout			65			65		

¹ See Output Power Limitation

² Contact the Company for operation with other input frequencies or different waveforms

³ Inrush current stays factor 10 below ETS 300132-1.

⁴ In the case of an overvoltage, the converter switches temporarily off, resulting in reduced output power.

Input Fuse

An input fuse (5 × 20 mm) in series with the input line (L) inside the converter protects against severe defects; see also *Safety and Installation Instructions*.

Table 3: Fuse Type

Series	Schurter type	Part number
LT	SPF 6.3 A, 250 V	0001.1012
UT	SPT 10 A, 250 V	0001.2514

Inrush Current

The converters exhibit an input capacitance of only 4 μF, resulting in a low and short peak current, when the converter is connected to the mains. During switch-on, the converter current can rise up to the input current limit I_{IL} .

As a direct result of the low and short inrush current and controlled charging procedure of the output capacitors, the converter can be hot swapped. The LT inrush current is a factor 10 smaller than defined in the ETS 300132-1 standard for Telecom systems. However the converter should be plugged-in smoothly, giving time to the output capacitors to be charged.

Input Under-/Overvoltage Lockout

If the specified input voltage range V_i is exceeded, the converter stops operation temporarily resulting in reduced output power and increased RFI. The input is protected by varistors. Continuous overvoltage will destroy the converter.

If the sinusoidal input voltage stays below the input under-voltage lockout threshold V_i , the converter will be inhibited.

Power Factor, Harmonics

Power factor correction PFC is achieved by controlling the input current waveform synchronously with the input voltage. PFC is active in all operating conditions (voltage regulation, output power limitation, current limitation).

The power factor control also works with different input voltage waveforms and frequencies. For special applications with different frequencies or non-sinusoidal waveforms, please contact Bel Power Solutions.

Efficiency

The extremely high efficiency (see Fig. 3) is achieved by using a single-step power factor corrected topology together with the most advanced technology in power conversion. It allows a very compact design in a fully enclosed case without forced cooling.

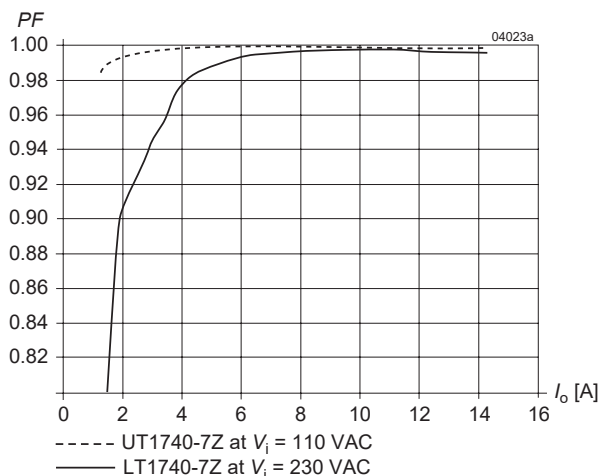

Fig. 2
Power factor

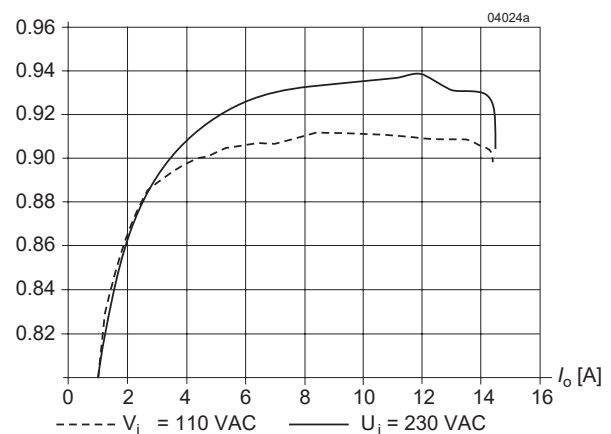

Fig. 3
Efficiency versus load of LT1701

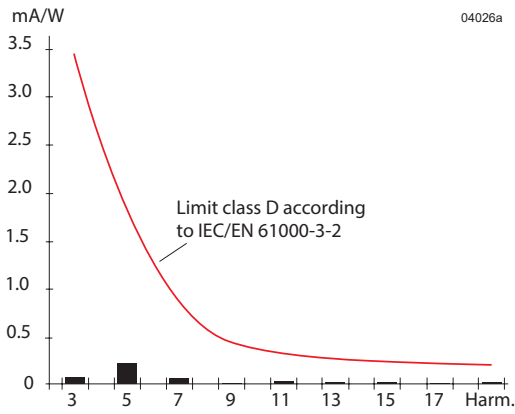

Fig. 4
Harmonic distortion at input LT1740-7Z, $V_i = V_{i nom}$, $I_o = I_{o nom}$

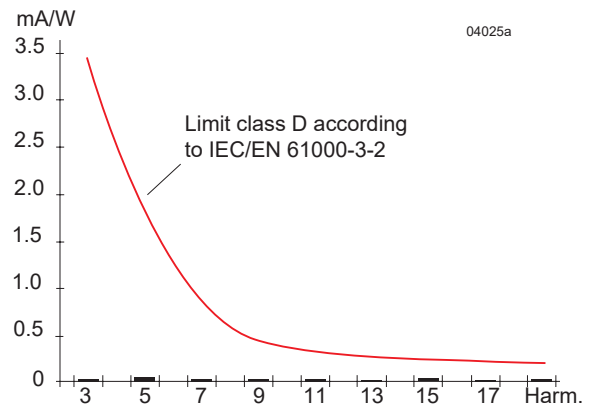

Fig. 5
Harmonic distortion at input UT1740-7Z, $V_i = V_{i nom}$, $I_o = I_{o nom}$

ELECTRICAL OUTPUT DATA

General conditions:

- $T_A = 20\text{ °C}$, unless specified.
- $V_i = V_{i\text{nom}}$, $f_i = 50\text{ Hz}$

Table 4: Output data of rectifier versions

Model		LT/UT1201			LT/UT1701			LT1702			Unit		
Characteristics		Conditions		min	typ	max	min	typ	max	min	typ	max	
$V_{o\text{ set}}$	Output voltage adjustment	$V_{i\text{ nom}}$		24.25			54.5			48.0			V
$V_{o\text{ set tol}}$	V_o setting tolerance	$I_o = 0.5 \cdot I_{o\text{ nom}}$		24.0	24.5		54.25	54.75		47.75	48.25		
V_o	Output voltage over input voltage and load ¹	$V_{i\text{ min}} - V_{i\text{ max}}^1$ $(0.01 - 1) \cdot I_{o\text{ nom}}$		23.35	24.95		52.8	55.8		46.3	49.3		
V_{oL}	Overvoltage protection by second control loop				32.5			59.3			59.3		
α_{V_o}	Temperature coefficient of output voltage				-5			-5			-5		mV/K
$I_{o\text{ nom}}$	Nominal output current				16			10			11		A
I_{oL}	Current limit ²	$V_o = 20\text{ V}$			18 ⁴			14.5			14.5		W
P_{oL}	Output power limit ²	$V_{i\text{ nom}}$			400			550			550		
V_o	Output voltage noise	Low frequency	$I_{o\text{ nom}}$			850			1000			1000	mV _{pp}
		Switching freq.	IEC/EN 61204 BW = 20 MHz			40			40			40	
		Total				900			1000			1000	
ΔV_{oI}	Static load regulation (droop) ¹	$(0.01 - 1) \cdot I_{o\text{ nom}}$			-6			-1.2			-1.2		V
ΔV_{oV}	Static line regulation	$V_{i\text{ min}} - V_{i\text{ max}}^1 \cdot I_{o\text{ nom}}$				0.3			0.8			0.8	
V_{od}	Dynamic load regulation ³	Voltage deviation	$V_{i\text{ nom}}$			1.7			2.2			2.2	
t_d		Recovery time	$0.1 \cdot I_{o\text{ nom}} \leftrightarrow I_{o\text{ nom}}$ IEC/EN 61204 ⁵			0.25			0.25			0.25	s
C_o	Internal output capacitance				86			41			41		mF

¹ Output voltage decreases with rising output current due to the droop characteristic to ease current sharing; see fig. 7.

² Due to the large output capacitance, the maximum transient value can be much higher.

³ Deviation limited by output overvoltage protection

⁴ No power limitation, but current limitation

⁵ See fig. *Dynamic load regulation*.

General conditions:

- $T_A = 20\text{ °C}$, unless specified.
- $V_i = V_{i\text{nom}}$, $f_i = 50\text{ Hz}$

Table 5: Output data of battery charger versions

Model		LT/UT1240-7Z			LT/UT1740-7Z			Unit	
Characteristics		Conditions		min	typ	max	min	typ	max
$V_{o\text{set}}$	Output voltage adjustment ⁶	$V_{i\text{nom}}$		27.25			54.5		
$V_{o\text{set tol}}$	V_o setting tolerance ⁶	$I_o = 0.5 \cdot I_{o\text{nom}}$		27.2	27.3		54.45	54.55	
V_o	Output voltage range ⁴			25.25	28.25		50.5	56.5	
	Output voltage over input voltage & load ^{1,6}	LT	$V_{i\text{min}} - V_{i\text{max}}$	26.8	27.6		53.8	55	
		UT	$(0.01 - 1) \cdot I_{o\text{nom}}$	26.9	27.6		53.8	56.6	
V_{oL}	Overvoltage protection by second control loop				32.5			59.3	
α_{V_o}	Temperature coefficient of output voltage				-3			-3	
$I_{o\text{nom}}$	Nominal output current				14.5			10	
I_{oL}	Current limit ²				20			14.5	
P_{oL}	Output power limit ²	$V_{i\text{nom}}$			400			550	
V_o	Output voltage noise	Low frequency	$I_{o\text{nom}}$		700			1000	
		Switching freq.	IEC/EN 61204		40			40	
		Total	BW = 20 MHz		750			1000	
ΔV_{oI}	Static load regulation (droop) ¹	$(0.01 - 1) \cdot I_{o\text{nom}}$			-0.4			-0.6	
ΔV_{oV}	Static line regulation	$V_{i\text{min}} - V_{i\text{max}}, I_{o\text{nom}}$				0.2			0.35
V_{od}	Dynamic load regulation ³	Voltage deviation	$V_{i\text{nom}}$		1.6			2.0	
t_d		Recovery time	$0.1 \cdot I_{o\text{nom}} \leftrightarrow I_{o\text{nom}}$		0.2			0.2	
C_o	Internal output capacitance				86			41	

¹ V_o decreases with rising output current due to the droop characteristic to ease current sharing; see fig. 8.

² Due to the large output capacitance, the maximum transient value can be much higher.

³ Deviation limited by output overvoltage protection

⁴ Defined by temperature sensor, by remote control, and by voltage selector switch

⁵ See fig. *Dynamic load regulation*.

⁶ Output voltage adjustment with $V_{cr} = 9.5\text{ V}$ (2.27 V/cell)

Output Characteristic

The models T1701/1702 and the battery chargers T1240/1740/1840 can be operated in 3 different modes:

- Output voltage regulation
- Output power limitation
- Output current limitation

Caution: In output power or current limitation mode, the max. ambient temperature T_A should not exceed 65 °C with free air convection cooling.

The output of all models is fully protected against continuous short circuit. The maximum constant current is limited to I_{oL} (see table *Electrical output data*). As the LEDs indicating the system status are driven from the output voltage, all LEDs switch off in the case of a short circuit.

Output Overvoltage Protection

A slight output voltage overshoot may occur at turn-on, inhibit release, or during fast load changes. A second, independent control loop interrupts the operation above V_{oL} and indicate it by the red warning LED. The output voltage remains below 60 V (ES1) under all operating conditions.

Note: There is no specific built-in protection against externally applied overvoltages or transients.

Output Voltage Regulation (Rectifier Version)

The output voltage is adjusted to a fixed value $V_{o\ set}$. It relates to the output current and the input voltage, which ensures current sharing without further precautions, when several converters are connected in parallel. Rising output current and falling input voltage lead to a decrease of the output voltage, according to the formula:

$$V_o \approx V_{o\ set\ tol} + (0.5 - I_o/I_{o\ nom}) \cdot \Delta V_{o\ i} + (\Delta V_i - \Delta V_{i\ nom})/100\ V \cdot \Delta V_{o\ v}$$

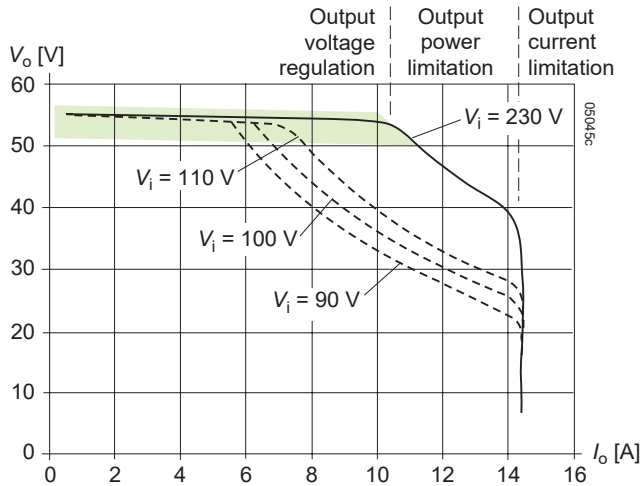

Fig. 6 Output characteristics LT1701-7 and LT1740-7Z

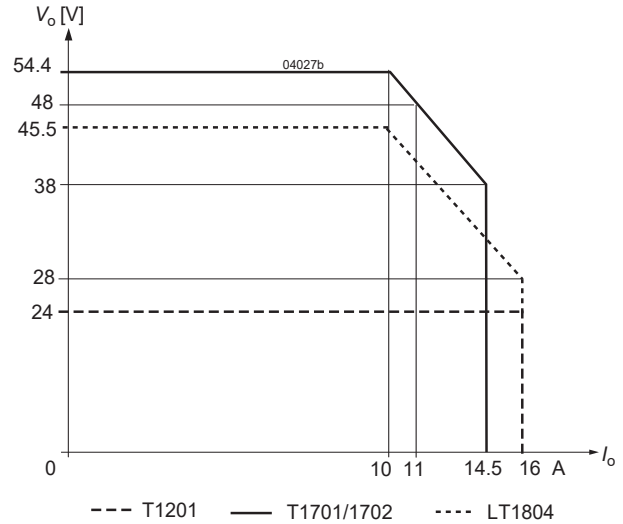

Fig. 7 Output characteristic of T1201, T1701/1702, LT1804.

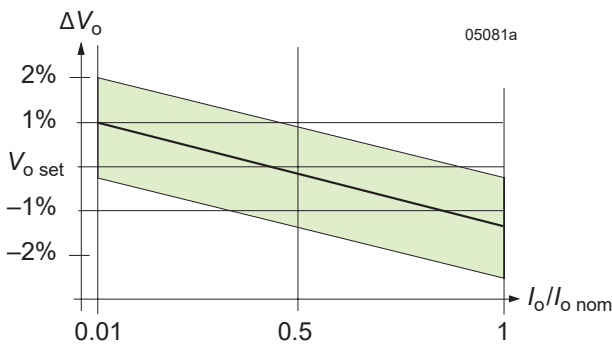

Fig. 8 Typical output droop (LT 1701)

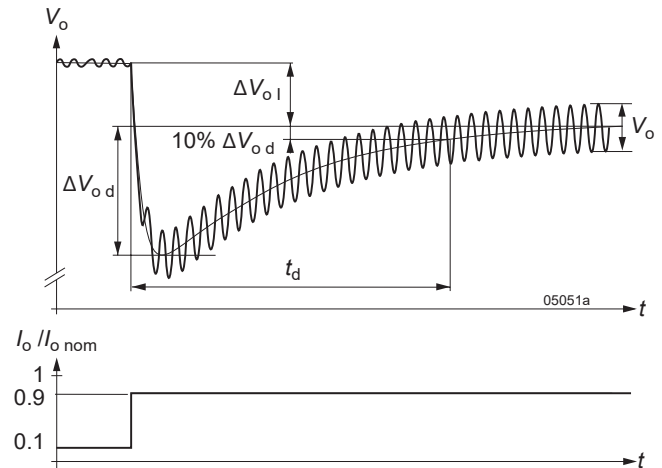

Fig. 9 Typ. dynamic characteristics (at load step)

Output Power Limitation (Rectifier Version)

Especially for power systems with an output voltage of 48 V, the rectifier models T1701/1702 exhibit an output power limitation mode. The output power is kept constant down to an output voltage of approximately 38 V. This provides improved start-up capability of power systems including switched-mode power supplies connected to the output (e.g. 48Q Series). At maximum load there is no need for a special start-up procedure.

The maximum input current is limited to $I_{i\ L}$. At lower input voltage $V_{i\ red}$ the maximum output power is limited to:

$$P_o \approx \eta \cdot V_{i\ red} \cdot I_{i\ L} \quad (\eta = \text{efficiency approx. } 90\%)$$

T1201 models have no output power limitation mode.



Pulse Loading (Rectifier Version)

To prevent the output and filter capacitors from overload, the superimposed AC ripple current at the output should be limited as shown in the figure below. For high-current pulse loads, external capacitors are recommended.

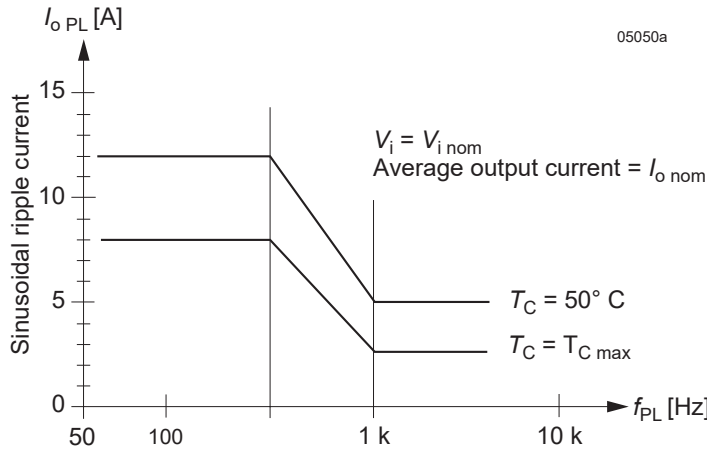

Fig. 10
Maximum AC ripple output current superimposed on the average output current $I_{o\text{ nom}}$ for LT1701.

Output Voltage Regulation (Battery Charger)

In normal operating mode (neither in power limitation nor in current limitation) the output is regulated by a voltage feedback loop. It is adjusted to $V_{o\text{ set}}$ and can be set by the cell voltage selector switch to the appropriate float charge voltage of the battery.

A control input (pin 28) allows for adjustment of the output voltage either by a voltage source, a temperature sensor, or an external potential divider (see *External Output Voltage Control*). For fine tuning, the converter is fitted with a trim potentiometer accessible from the rear side.

The output voltage relates to the output current and the input voltage, which ensures current sharing without further precautions, when several converters are connected in parallel. An increase in output current and a decrease in input voltage decrease the output voltage, according to the formula:

$$V_o \approx V_{o\text{ set tol}} + (0.5 - I_o/I_{o\text{ nom}}) \cdot \Delta V_{o1} + (\Delta V_i - \Delta V_{i\text{ nom}})/100 \text{ V} \cdot \Delta V_{oV}$$

The dynamic characteristic is shown in fig. 9.

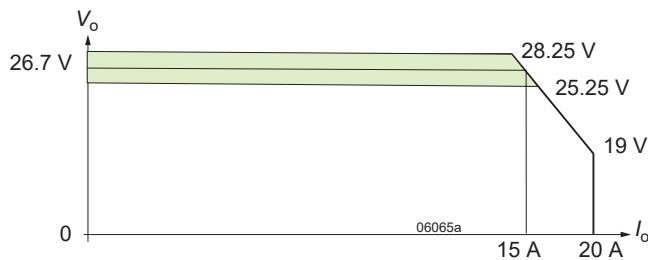

Fig. 11
Output characteristic of T1240 (typ.).
The droop is shown in fig. 12.

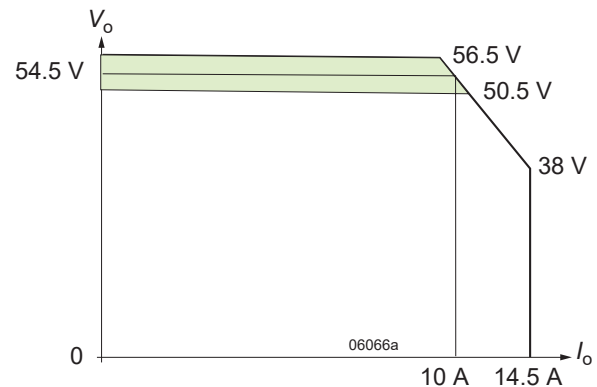

Fig. 12
Output characteristic of T1740 (typ.).
The droop is shown in fig. 12.

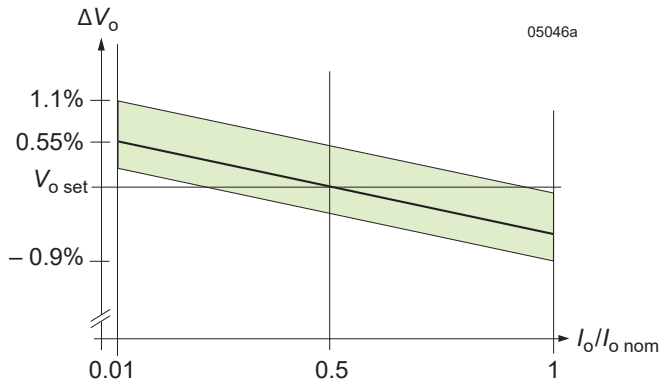

Fig. 13
Typical output droop T1240/1740

Output Power Limitation (Battery Charger)

All battery charger versions exhibit an output power limitation mode, where the output power is kept constant from 2.35 V/cell (for lead acid batteries) to 1.6 V/cell.

The maximum input current is limited to I_{iL} . At lower input voltage V_{ired} , the maximum output power is limited to:

$$P_o \approx \eta \cdot V_{ired} \cdot I_{iL} \quad (\eta = \text{efficiency approx. 90\%})$$

Inhibit (Rectifier Version)

The rectifier version converters are equipped with a simple inhibit function (with no adjustment of V_o). The converter is enabled by a logic high signal and disabled by a logic low signal. This input is TTL/CMOS compatible, a resistor $<50 \Omega$ disables the converter, a resistor $>30 \text{ k}\Omega$ enables it. The switch-on time t_r , i.e., the time delay between powering until the full output power is available, is typically 100 ms.

The hold-up time at the output after inhibiting depends on the load, the internal and external capacitance at the output.

Note: The inhibit input is protected against overvoltage up to 60 V.

Table 6: Characteristics of the inhibit signal

Characteristics		Conditions	min	typ	max	Units
V_{inh}	Inhibit voltage	$V_o = \text{on}$	2.5	60		V
R_{inh}	Resistance to Vo-	$V_o = \text{on}$	30			k Ω
V_{inh}	Inhibit voltage	$V_o = \text{off}$	-0.7	0.4		V
R_{inh}	Resistance	$V_o = \text{off}$		50		Ω
t_r	Switch-on time until full power avail.	$V_{i,nom}$		100		ms
P_{inh}	Input power with inhibited unit			3		W

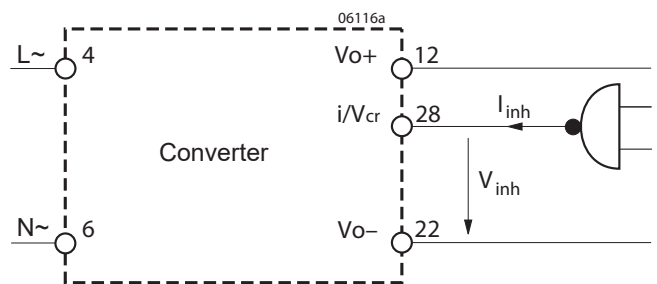

Fig. 14
Inhibit connection

Hold-Up Time

The hold-up time depends upon the output voltage at the time of failure, the minimum acceptable output voltage, and the load according to the formula:

$$t_{\text{hold}} = \frac{V_o^2 - V_{o \text{ min v}}^2}{2 \cdot P_o} \cdot (C_o + C_{\text{ext}})$$

where:

- V_o = Output voltage at the moment of mains' failure
- $V_{o \text{ min v}}$ = Minimum acceptable output voltage
- P_o = Average output power during hold-up time
- C_o = Internal output capacitance
- C_{ext} = External output capacitance

Examples of t_{hold} are given in the table below:

Table 7: Hold-up time t_{hold} for T1701

$V_o = 54 \text{ V}$ P_o [W]	$V_{o \text{ min v}}$				Unit
	46 V	43 V	40 V	38 V	
100	164	219	270	302	ms
200	82	109	135	151	
300	55	73	90	101	
400	41	55	67	75	
500	33	44	54	60	
550	30	40	49	55	

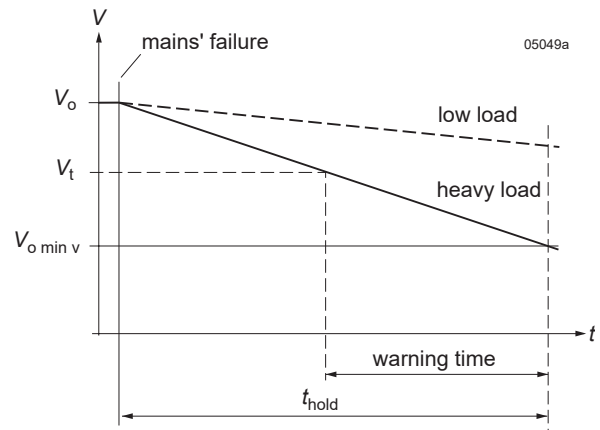

Fig. 15 Hold-up and warning time with Power Down output signal.

Note: The table *Hold-up time* also informs about the warning time of the Power Down signal. For example, if the threshold level V_t of the Power Down signal is set to 43 V and the minimum acceptable voltage of the load is 38 V, the time between the activation of the power-down signal and the switch-off of the load (550 W) will be 15 ms (= 55 ms – 40 ms).

Series and Parallel Connection

The output of the T Series converters may either be connected in series or in parallel.

Connection in parallel: Current sharing between paralleled converters is ensured by the output droop (slope) characteristic.

Note: Several Txx40 battery chargers connected in parallel can be controlled by a single voltage source or a single sensor wired to the inputs i/Vcr.

Connection in series: A maximum of two T Series converters may be connected in series, however the resulting output voltage of up to 110 V would no longer be ES1.

CONTROL FEATURES OF THE BATTERY CHARGERS

According to the recommendations of battery manufacturers, the float-charge voltage of lead-acid batteries should be temperature-compensated. Depending on the battery type and size, charging with different temperature coefficients may be required. An excessive float-charge voltage may damage the battery through overcharging.

Most lead-acid battery manufacturers recommend cell voltages between 2.23 V and 2.32 V, with the nominal cell voltage defined at 20 °C and temperature coefficients per cell between -3 and -4 mV/K.

The value of the negative temperature coefficient is specified by the type of T temperature sensor.

With the cell voltage selector switch Z, the required cell voltage can be adjusted at the rear of the converter, making the system flexible to different float-charge voltages. If the selector switch Z is not applicable, a cell voltage adjustment can also be provided by the temperature sensor; see *Temperature Sensor T*).

Although it is not recommended, the output voltage can be set to a fixed value without temperature compensation by an external voltage source or a resistive voltage divider at the remote control input, for instance if the battery temperature shall be controlled by other systems; see *External Output Voltage Control*.

Cell Voltage Selector Switch (Z)

The battery chargers are equipped with a cell voltage selector switch at the rear side, which provides an easy way of external adjustment to the required float-charge voltage. Each switch position allows a step in the output voltage of 10 mV per cell, whereby the switch position "0" represents a cell voltage of 2.23 V at 20 °C; position "C" gives 2.35 V per cell.

The cell voltage selector switch fits together with the 2.23 V temperature sensor. The float-charge voltage is set by the switch, and the temperature coefficient is specified by the sensor type.

Caution: Setting the switch to the correct battery cell voltage is vital for the proper operation of a battery system.

Note: Switching to a different cell voltage while the battery charger is operating may cause a short distortion of the output voltage.

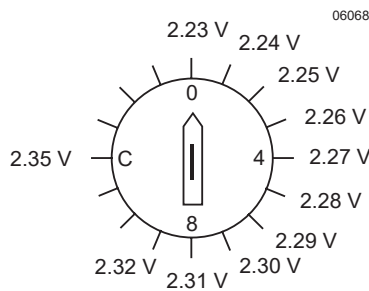

Fig. 16
Cell voltage selector switch

Potentiometer for Fine Tuning

The battery chargers are equipped with a one-turn potentiometer for fine tuning of the output voltage to within $\pm 3.7\%$ of V_o . The potentiometer is protected by a plastic cover. To adjust the output voltage for improved current sharing or compensation for voltage drops over the load lines, each battery charger in a system should be unplugged and adjusted individually to the same output voltage at equal load; otherwise current sharing may adversely be affected.

External Output Voltage Control

The i/Vcr control input (pin 28) provides two functions:

- External adjustment of the output voltage
- Inhibiting of the converter.

A voltage <0.4 V inhibits the output, a voltage >2.5 V enables it.

With the i/Vcr input in the range of 5.5 V to 11.5 V, the output voltage V_{o_set} can be adjusted within a range of +3.6% to -7.9%. This feature is optimized to control the float-charge of a lead acid battery.

Outside of the control range, the sensor monitoring circuit generates a system error signal (see also *System Good*).

In the case of a excessively high control voltage, the output voltage is reduced.

The remote control input is protected against DC overvoltage up to 60 V.

Table 8: Characteristics of the remote control

Characteristics		Conditions	LT/UT1240 typ	LT/UT1740	Unit
V_o	Output voltage at	V_{cr} fail 2.5 – 5.5 V	25.25	50.5 V	V
		V_{cr} control 5.5 – 11.5 V	$22.5 + V_{cr} \cdot 0.5$	$45 + V_{cr}$	
		V_{cr} clamp 11.5 – 14 V	28.25	56.5	
		V_{cr} fail 14 – 60 V	25.25	50.5	
R_{cr}	Input impedance	$V_{i\text{nom}}, 0.5 \cdot I_{o\text{nom}}$	1	1	MΩ
f_{cr}	Frequency limit		1	1	Hz

Table 9: Characteristics of the inhibit signal

Characteristics			Conditions	min	typ	max	Unit
V_{inh}	Inhibit voltage	$V_o = \text{on}$	$V_{i\text{min}} - V_{i\text{max}}, T_{C\text{min}} - T_{C\text{max}}$	2.5		60	V
R_{inh}	Resistance to Vo-	$V_o = \text{on}$		30 k			Ω
V_{inh}	Inhibit voltage	$V_o = \text{off}$		-0.7		0.4	V
R_{inh}	Resistance to Vo-	$V_o = \text{off}$				50	Ω
t_r	Switch on time until full power available	$V_{i\text{nom}}$			100		ms
P_{inh}	Input power at inhibited converter	$V_{i\text{nom}}$			3		W

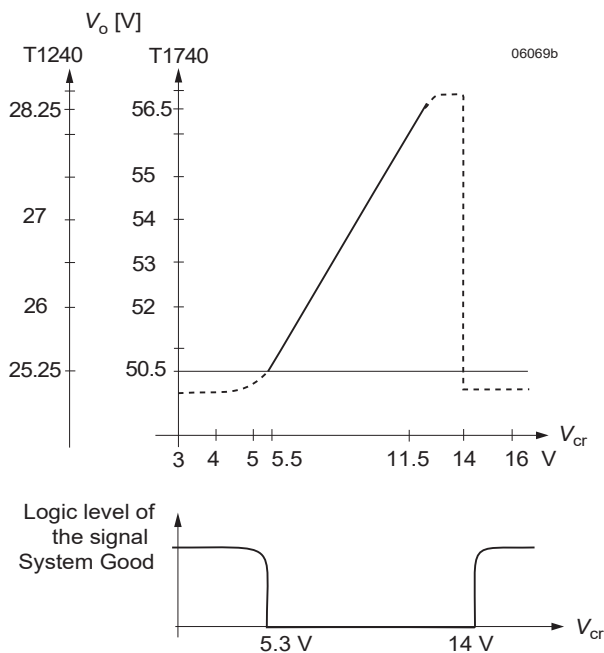

Fig. 17
Output voltage V_o versus control voltage V_{cr} , with the corresponding signal System Good

Note: An open inhibit/ V_{cr} remote control input leads to a sensor error signal which is indicated by the Error LED at the front and high impedance of the “System good” signal. The output voltage is reduced to V_{cr} fail condition. If the voltage selector switch Z is not set at 2.23 V per cell, the V_{cr} fail voltage rises accordingly.

The inhibit input of battery charger models is not TTL/CMOS compatible and should be triggered by a switch, a relay, or an open-collector transistor.

Control by external resistors

With a resistive potential divider or a potentiometer connected to the remote control input, a fixed output voltage can be programmed:

$$V_{cr} = V_o - 45 \text{ V} \quad (\text{T1740})$$

$$V_{cr} = 2 \cdot V_o - 45 \text{ V} \quad (\text{T1240})$$

$$V_{cr} = \frac{V_o \cdot R_2}{(R_1 + R_2)}$$

R_2 : Value with 1 MΩ internal resistance in parallel with R.

It is mandatory that:

$$\frac{(R_1 \cdot R_2)}{(R_1 + R_2)} > 35 \text{ k}\Omega$$

otherwise the converter might not be able to start.

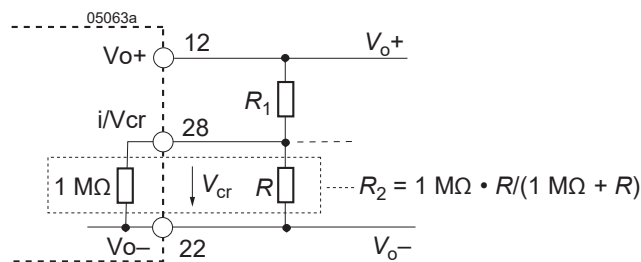

Fig. 18
Voltage setting by external resistors

Control by an external voltage source

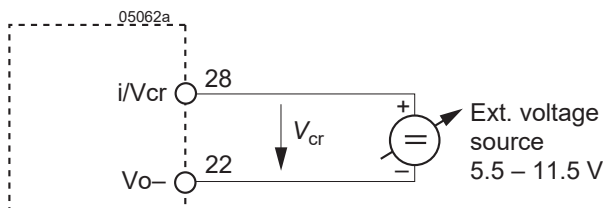

Fig. 19
Voltage setting by an external voltage source

Control by the temperature sensor T

The temperature sensor provides a temperature-compensated charging process for lead-acid batteries; see *Accessories, Temperature Sensor T*.

AUXILIARY FUNCTIONS

Available Signals and Status Monitoring

The T Series exhibits an inhibit function as well as several voltage monitoring and indicating functions for easy control and surveillance of a complete customer-specific power supply system. All the surveillance functions are driven from the output. Consequently, it also operates, when the input voltage is off, down to an output voltage of 5 V. The power consumption of the surveillance circuit is typically 10 to 20 mA.

Available functions:

– Power Down	D	pin 30
	D set	pin 32
– System Good	Sys In	pin 24
	Sys Out	pin 26
– Inhibit/Vcr remote control	i/Vcr	pin 28

The status is indicated by 3 LEDs on the front panel:

– System	(OK)	green
– V_o	(OK)	green
– Error		red

Test sockets at the front panel allow easy measurement of V_o .

Power Down Function

The power down circuitry monitors V_o and changes the status of output D (pin 30) from low to high impedance, when V_o falls below the low threshold level, and changes back to low impedance, when V_o exceeds the upper threshold level.

The rectifier versions have a relatively small hysteresis of 1 V, the battery charger versions have a large hysteresis. The upper threshold level is given, but the low threshold level is externally adjustable at the D set pin 32. The Power Down signal D (pin 30) can for example be used as a save data signal, for low voltage warning, as a low-battery signal to avoid deep discharge of the battery, or to prevent connected converters from starting-up at a low bus voltage. For application examples, see figures below using the signal D.

As it is driven from the output, the power down circuitry operates independently of the input voltage and the load conditions, even if the converter is inhibited.

The standard version monitors V_o internally; see fig. 20.

With option D, the output voltage can be sensed externally, for example, to monitor the system bus decoupled from the power supplies by diodes or fuses. An external resistor of 43.2 k Ω 1% must be fitted into the sense line to the bus; see fig. 21 below.

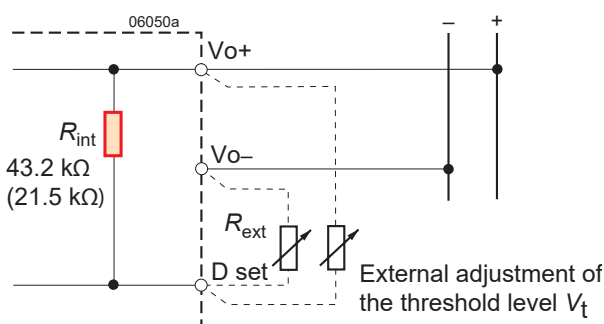

Fig. 20
Standard version; the power down circuitry monitors directly V_o via R_{int} . R_{ext} is not necessary.

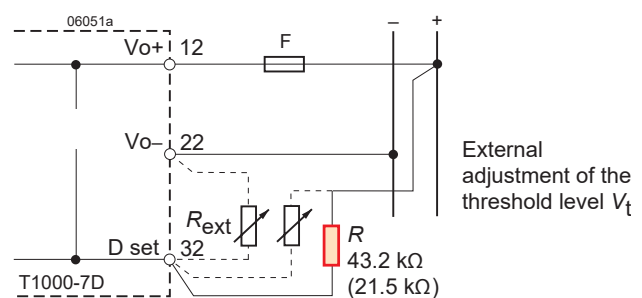

Fig. 21
Option D (D-set internally not connected); the power down circuitry monitors the power bus decoupled by the fuse F.

Adjustment of the threshold level

With the resistor (R_{ext}) connected to D set (pin 32) and Vo- (or Vo+), the low threshold level can be increased (or decreased) respectively; see fig. 20 and 21.

If the D set input is left open-circuit, the low threshold level of the power down circuitry is factory-set to:

T12xx: $V_{t\ set} = 21.0\ V \quad \pm 0.2\ V$

T17xx: $V_{t\ set} = 42.5\ V \quad \pm 0.5\ V$

The approximate resistor values for given threshold levels can be calculated from the table below:

Table 10: Calculation of R_{ext}

Model	$V_t > V_{t\ set}$ (R_{ext} connected to Vo-)	$V_t < V_{t\ set}$ (R_{ext} connected to Vo+)
T12xx	$R_{ext}(V_t) = \frac{463.5}{V_t - 21.0} \text{ [k}\Omega\text{]}$	$R_{ext}(V_t) = \frac{43.2 V_t - 463.5}{21.0 - V_t} \text{ [k}\Omega\text{]}$
T17xx	$R_{ext}(V_t) = \frac{933}{V_t - 42.5} \text{ [k}\Omega\text{]}$	$R_{ext}(V_t) = \frac{43.2 V_t - 933}{42.5 - V_t} \text{ [k}\Omega\text{]}$

Table 11: Typ. values for R_{ext} for a given V_t value for LT1740

Characteristics	Conditions	V_t	Unit
V_t Power down threshold level set by R_{ext}	69 kΩ to Vo+	34.4	V
	106 kΩ to Vo+	36.4	
	254 kΩ to Vo+	39.5	
	left open-circuit	42.5	
	309 kΩ to Vo-	45.5	
	154 kΩ to Vo-	48.5	
	102 kΩ to Vo-	51.6	

The threshold level is adjusted for a DC output voltage. If in operation a sinusoidal low frequency output ripple is superimposed to the DC output voltage, it can be estimated with $V_{ov} = I_o / (2 \cdot \pi \cdot f \cdot C_o)$, where C_o is the internal output capacitance.

Upper threshold level

The upper threshold level of the power down function is given.

The rectifier models have a relatively small hysteresis of 1 V to prevent the signal from oscillation.

The battery chargers have a larger hysteresis. The upper level is set at 2.05 V/cell.

To avoid deep discharge of the battery, the load should be disconnected from the battery at the low level of the power down signal. The battery voltage will then recover slowly up to its chemical equilibrium, about 2 V/cell. The load may not be connected again to the battery, until the T converter is operating and charging it. Then the output voltage will be higher than 2.05 V/cell.

High level of output signal D (pin 30):

LT/UT1240: $24.6\ V \quad \pm 0.3\ V$

LT/UT1740: $49.2\ V \quad \pm 0.5\ V$

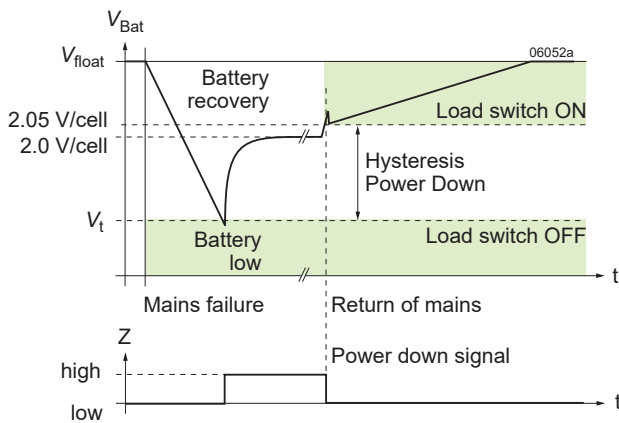

Fig. 22

Hysteresis of D output signal for battery chargers with corresponding level of Power Down signal

Signal output characteristics

Output D (pin 30) is an open-collector signal, referenced to Vo-, protected by a 62 V Zener diode; it is well suited to drive an external relay.

Under normal operating conditions ($V_o > V_t$), output D has low impedance. If the output voltage drops below the power down threshold level, output D becomes high impedance.

Table 12: Characteristics of power down functions

Characteristics	Conditions	min	typ	max	Units
I_D	Output sink current	$T_{C\ min} - T_{C\ max}$		50 ¹	V
V_{sat}	Saturation voltage	$I_D = 50\ \text{mA}$		0.2	V
V_Z	Zener voltage			62	
P_Z	Z-diode P_{LOSS}	$T_C = 95\ ^\circ\text{C}$		500	mW

¹ To be limited to 50 mA by the external circuitry.

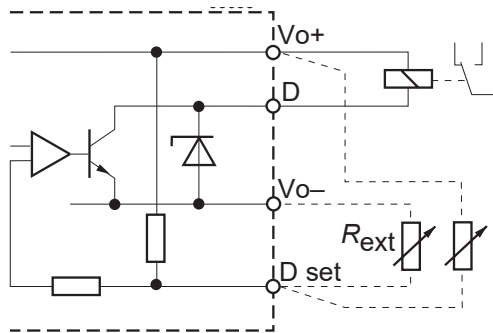

Fig. 23
Power down function (D output)
– External adjustment of threshold level V_t
– Signal electrically isolated by an external relay

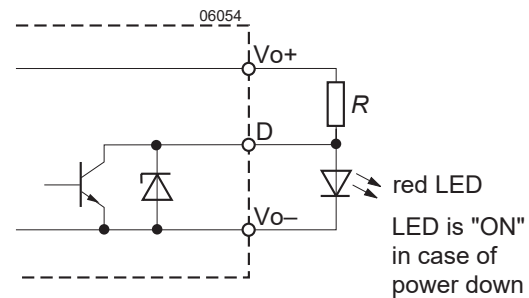

Fig. 24
Remote indication of signal D by LED

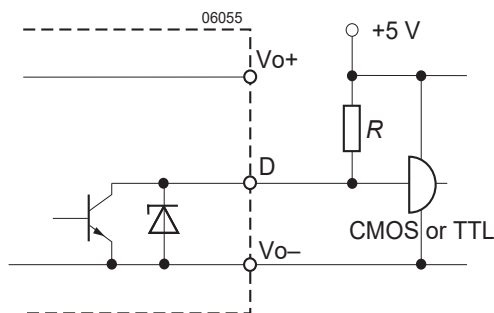

Fig. 25
Remote indication of the output voltage status (output D) by CMOS/TTL interface (e.g., for data saving)

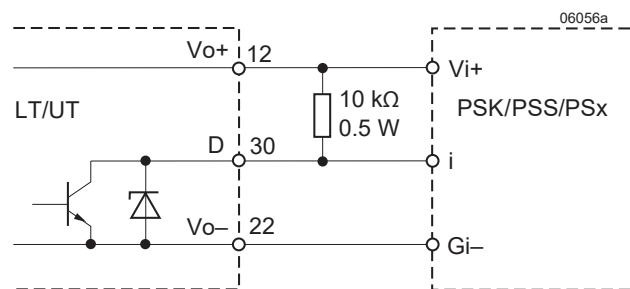

Fig. 26
Output D signal used as inhibit to enable a system start-up in the case of subsequently connected step-down converters PSK/PSS/PSx with low start-up voltage. (For 48Q/CQ units, no pull-up resistor is required.)

Table 13: Characteristics of System Good input and output

Characteristics	Conditions	min	typ	max	Units	
I_{Trig}	Trigger level for logic	current-driven		100	μA	
V_{Trig}	low input (= System OK)	voltage-driven		-0.4	6.2	V
I_{Trig}	Trigger level for logic	current-driven		0	A	
V_{Trig}	high input (= System Failure)	voltage-driven		>7.5	60	V
I_{sys}	Output sink current ¹			50	mA	
V_{sat}	Saturation voltage	$I_{Sys\ Out} = 50\ \text{mA}$		0.2	V	
V_Z	Zener voltage protection diode			62		
P_Z	Power dissipation Zener diode	$T_C = 95\ ^\circ\text{C}$		500	mW	

¹ To be limited to 50 mA by the external circuitry.

System Good Function

The Sys Out signal (pin 26) provides information about the general function of the converter. It can be used to monitor the status of a single T Series converter, or can be linked with other signals within a power system to drive one single-logic signal for the status of the whole system by connecting the output Sys Out of one converter to the input Sys In (pin 24) of the next one. Low voltage (impedance) of the input and output has the meaning of “system good”. The first input of the system has to be connected to Vo-.

The signal Sys Out is activated (low impedance), if the following conditions are met:

No external fault

- the Sys In signal (pin 24) is logic low,

AND:

No faults monitored by the T Series converter, such as:

- Input overvoltage
- Input undervoltage (mains failure)
- Output overvoltage
- Output short circuit
- Internal overtemperature
- Internal circuit fault.
- i/Vcr input error such as voltage $< 2.5\text{ V}$ (rectifier type); control voltage out of range $5.3\text{ V} > V_{cr} > 14\text{ V}$ (battery charger), or sensor not connected, open remote control input.

Signal input

The input Sys In (pin 24) can be voltage- or current- driven. To trigger the internal comparator, the voltage at the Sys In pin has to be $< 6.2\text{ V}$, if voltage-driven. If current-driven, the sink current to Vo- has to be $> 100\text{ }\mu\text{A}$. An easy way to drive this input is achieved by means of an open collector transistor, or a 10 V CMOS interface.

Note: If only the internal status of a T Series converter should be monitored, Sys In has to be connected to Vo-.

Signal output

The signal Sys Out (pin 26) has the meaning of “system good”. It is built by an open collector transistor referenced to Vo-, protected by a 62 V Zener diode.

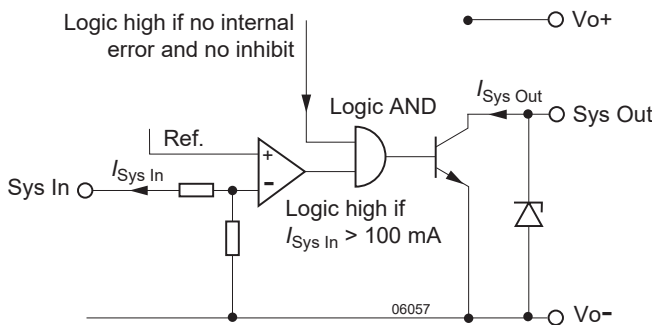

Fig. 27
Equivalent circuit of Sys In and Sys Out

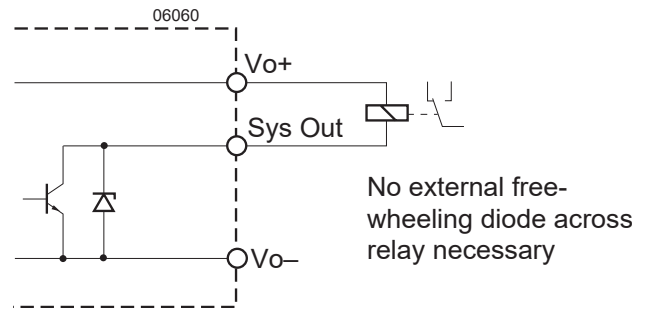

Fig. 28
System status signal electrically isolated by an external relay

Series and Parallel Connection of Power Down and System Good

To achieve a logic-OR function of the signals Sys Out and D, connect the D output to Sys In. The desired function is then obtained from the Sys Out output. The output signal becomes high, if the output voltage is lower than the threshold of the power down circuit, inhibit is applied, or an internal error has occurred.

To achieve a logic AND function of the Sys Out and D, connect the D output with the Sys Out. This combination generates an output signal only in the case of severe system errors. Only a T system fault together with a simultaneous power down of the output voltage will cause this output signal to become high impedance.

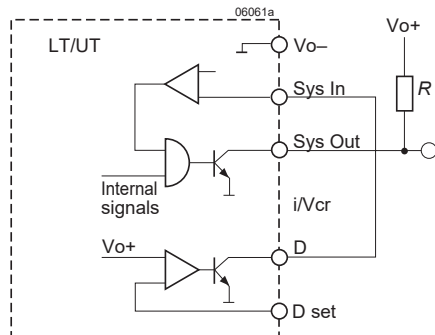

Fig. 29
Sys out and D connected in series. The output signal will indicate an error at start-up.

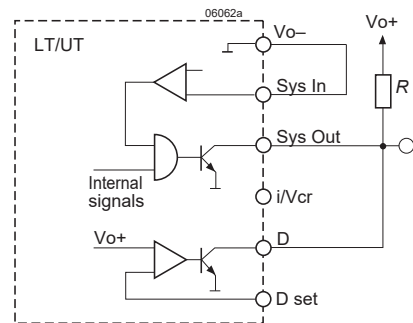

Fig. 30
Sys out and D connected in parallel.

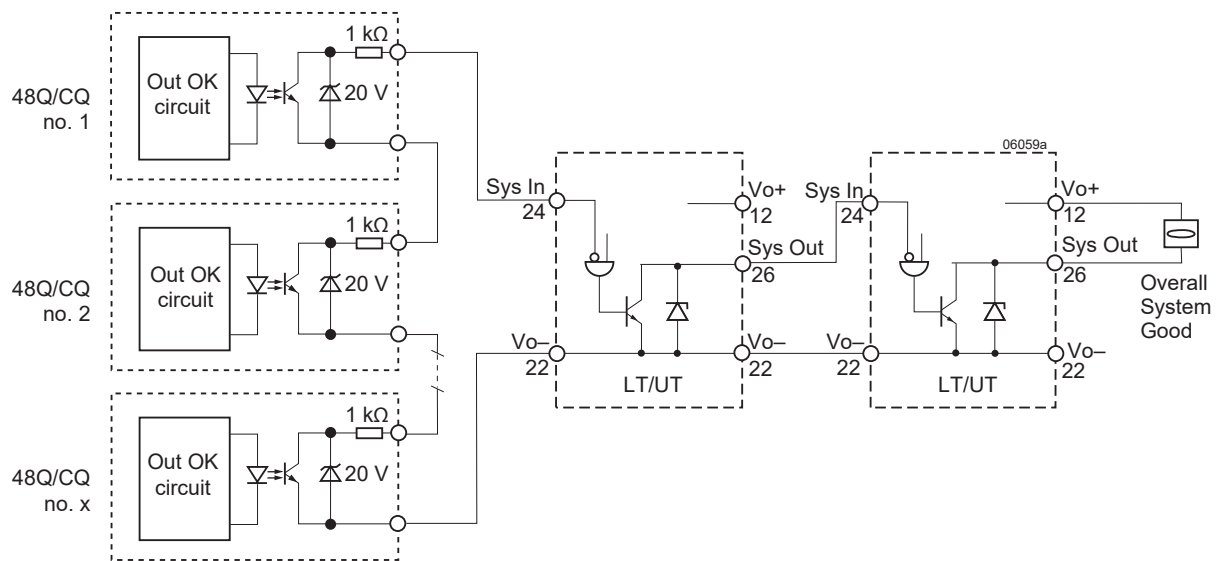

Fig. 31
Wired AND of isolated open collector signals (e.g. the OUT OK signal of 48/CQ units) with the Sys Out signals of T units in series to achieve one signal about the status of the whole system

Table 14: System monitoring.

Signal status and LED display status depending on the situation of the various system elements

Possible Situation	Open collector output		LED		
	System Good	Power Good	Sys OK	V _o OK	Error
All OK	low	low	on	on	off
No mains and battery OK or no mains and $V_o > V_t$	high	low	off	on	on
Unit inhibited and battery OK or unit inhibited and $V_o > V_t$					
Internal error					
Sys In input	high	low	off	on	off
No mains and battery low or no mains and $V_o < V_t$	high	high	off	off	on ¹
Short circuit on LT/UT output, $V_o < 4 V$	high	high	off	off	off
Current limit LT/UT output, $V_o > 4 V$, $V_o < V_t$	low	high	on	off	on
Battery chargers: sensor not connected or out of range	high	low	off	on	on

¹ LED is on until the output capacitors are discharged.

² Sys In connected to Vo-.

³ Sys In not connected to Vo- (single T status monitoring) or system status monitoring.

Display Status of LEDs

LED Sys OK

A green LED corresponds to the signal System Good. It lights, if no internal or external error is detected.

LED V_o OK

Another green LED indicates the output voltage status, corresponding to the signal Power Down. The LED lights, as long as V_o exceeds the upper threshold level and has not fallen below the low threshold level V_{L1} .

LED Error

This red LED lights, if one or more of the following conditions are detected:

- Input overvoltage
- Input undervoltage (mains failure)
- Output overvoltage
- Output short circuit
- Output voltage below threshold V_t
- Internal overtemperature
- Internal circuit fault
- i/Vcr remote control input error, such as:
 - Inhibit voltage < 2.5 V (rectifier models)
 - Remote control voltage V_{cr} out of range 5.3 – 14 V (battery chargers)
 - Sensor not connected, open remote control input.

DIFFERENT CONFIGURATIONS AND APPLICATIONS

Power Boosting, Redundant Configuration, Hot Swap

For redundant configurations the outputs should be decoupled by ORing diodes, protecting the DC-bus in case of an internal short circuit at the output of one converter.

Decoupling can also be done using appropriate fuses in the output path of each converter. If the battery voltage has to be monitored, choose option D.

ORing diodes provide reverse polarity protection with no reverse current in case of hot plug-in, but have the disadvantage of some forward voltage drop.

For battery applications, decoupling with fuses is recommended, since the voltage drop over the diodes would decrease the battery voltage. In case of an internal short circuit of a converter, the battery will deliver a very large current causing the respective fuse to blow. The fuse should be mounted in the positive power path of the converter, since the monitoring signals are referenced to the negative path. The fuse type should be suitable for DC application having a current rating of 20 A or more with high breaking capability, e.g., Littlefuse, series 314.

To enable hot plug-in in systems decoupled with fuses, the T Series converters are fitted with an NTC resistor, limiting the reverse current flowing into the discharged output capacitors (see *Functional Description*).

For this purpose HC+ (pin 16) and HC- (pin 18) have to be connected to V_{o+} and V_{o-} respectively; see fig. 33. Since pins 16 and 18 are leading pins, the output capacitors are precharged through the internal NTC resistor, before any other pin makes contact. This protects the connector and prevents the DC bus voltage from dropping during hot plug-in. Hot swap should be done gently. Subsequent hot-swap actions should be avoided. After disconnecting an operating converter, it should be cooled down prior to reconnecting to the bus to avoid damage of the fuse or the converter.

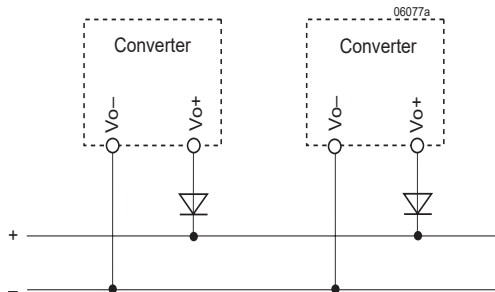

Fig. 32
Redundant configuration without battery back-up

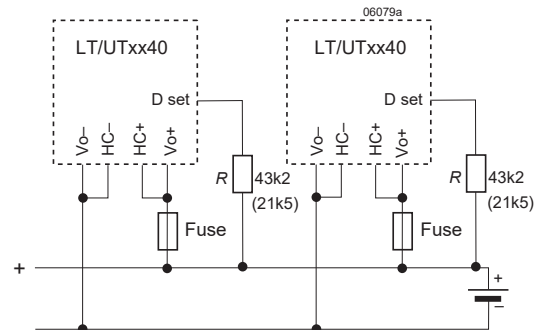

Fig. 33
T xx40 with battery back-up. Power Down signal monitoring the battery voltage.

Note: The internal NTC limits the reverse charge current flowing into the output capacitors, when the converter is plugged into a battery-buffered bus. Should however the converter already be connected, when the battery is switched to the bus, the resulting charge current will not be limited. To avoid having the fuse blow or a possible arc across the circuit breaker, the battery charger should be powered by the mains prior to connecting the battery. With ORing diodes, no reverse charge current flows from the power bus into the output capacitors.

Battery Size and Ripple Current

Some consideration should be given to the battery size. According to VDE 0510 part 2, the low frequency ripple current of the floating charge current should not exceed 5 A per 100 Ah capacity (0.05 C). The power factor corrected single step conversion of the line input voltage to the low DC output voltage generates a ripple voltage at the output of twice the input frequency, causing a ripple current into the connected battery.

For systems where only a small battery back-up time is required, battery charging by one T unit may be sufficient; see fig. below.

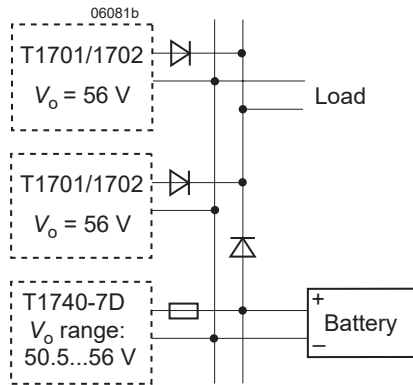

Fig. 34
Configuration for a larger system with only a small battery

Caution: Lead-acid batteries can generate certain amounts of H₂ and O₂ gas, which can form explosive gas mixtures. Sufficient ventilation must be provided in battery cabinets and installation rooms.

Note: Local regulations must be observed. Further information about designing battery systems is contained in VDE 0510, part 2.

Combination with DC-DC Converters

The T Series converters are designed to be operated with DC-DC converter loads. Particularly suitable are 48Q models, as they start working at approx. 38 V, thus avoiding high currents at ramp-up. But also other series may be used, for instance our CQ or P Series.

In a complete power system consisting of several T converters connected in parallel combined with 48Q/CQ units, it may be desirable to have one common signal indicating the status of the whole system.

The DC-DC converters provide a galvanically isolated signal Out OK. To obtain a logic AND, all Out OK signals should be connected in series; see fig. below:

If in a system with 2 redundant T Series converters Power Down is desired as one common signal, simply connect the D pins of the two T converters. Then, Power Down only becomes active, if both T converters fail, which would result in the bus voltage failing (see fig. below).

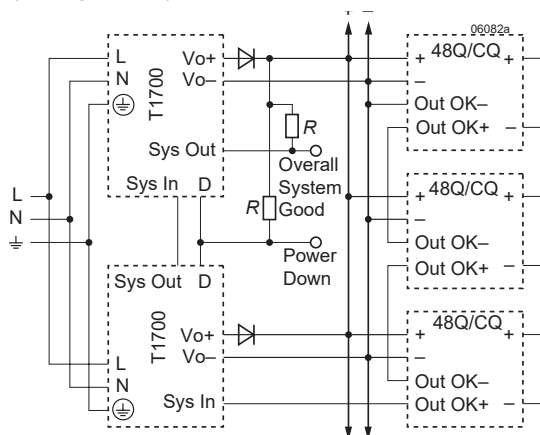

Fig. 35
Overall System Good and Power Down signal in a redundant system



Low-Battery Discharge Protection

Since all monitoring functions are powered by the output of the T converter or the battery, in the case of a mains' failure, Power Down can be used to monitor the status of the battery and to disconnect the load or part of it via the inhibit of the connected DC/DC converters, when the battery voltage drops below the threshold level of Power Down. This prevents further discharge of the battery.

Storing the System Good Signal

For battery back-up systems located in inaccessible areas it could be of interest to know, whether there has been a Power Fail (interruption of the mains). To obtain this information, Sys Out should be connected to Sys In with a reset button connected to Vo-. In this way a system failure like an interruption of the mains will be stored at Sys Out until, the reset button is pressed.

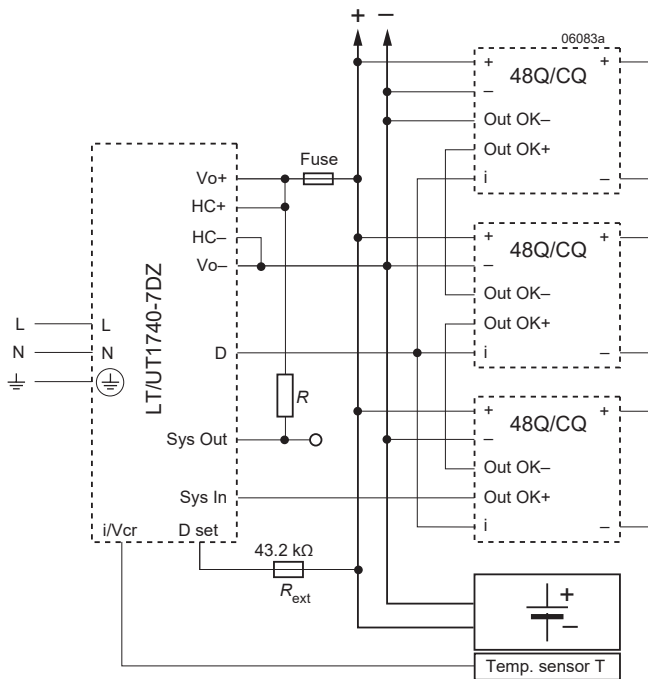

Fig. 36
Disconnecting the loads at low battery voltage in case of mains' failure

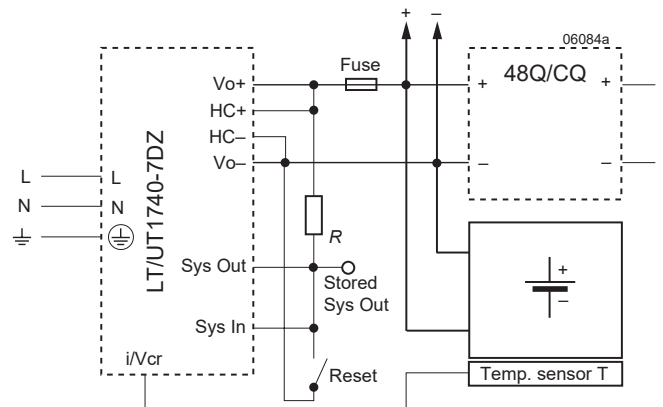

Fig. 37
Storing the System Good signal

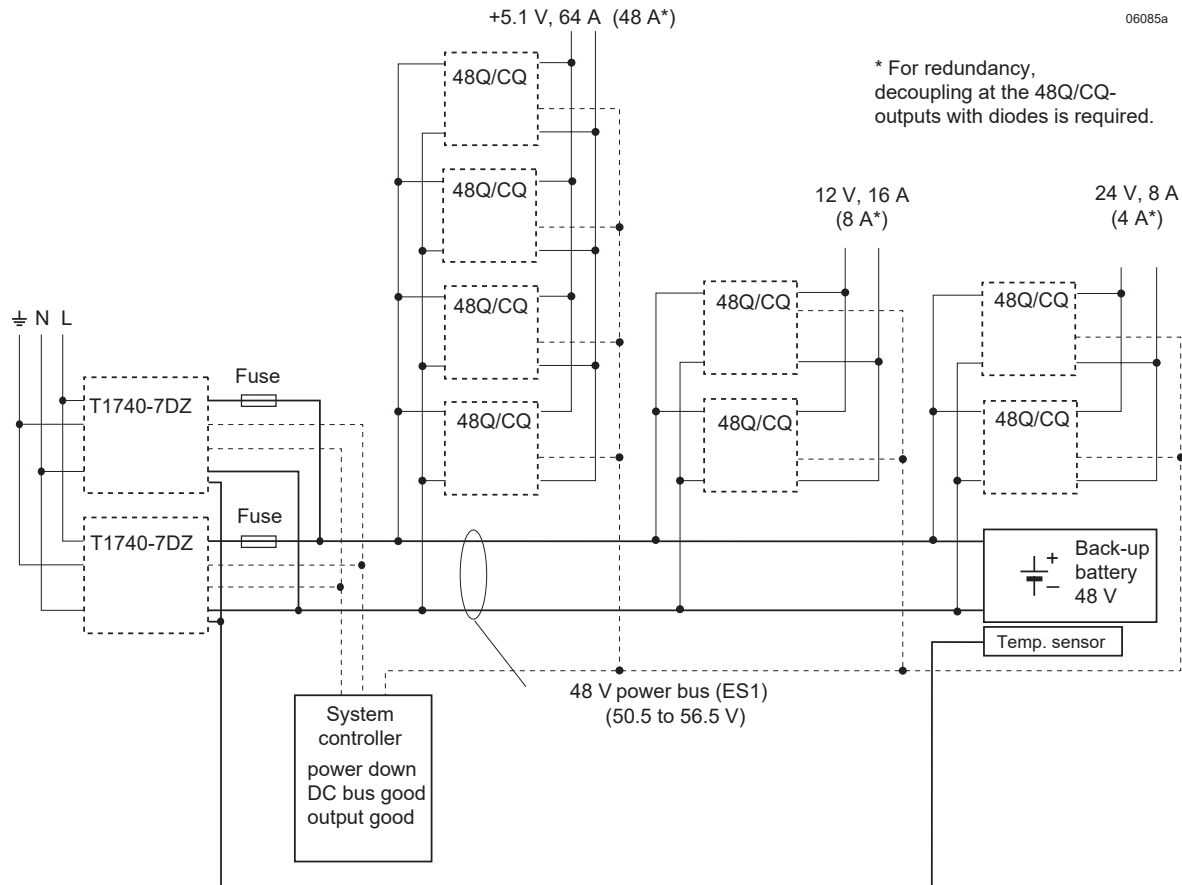

Fig. 38
UPS uninterruptible power supply system

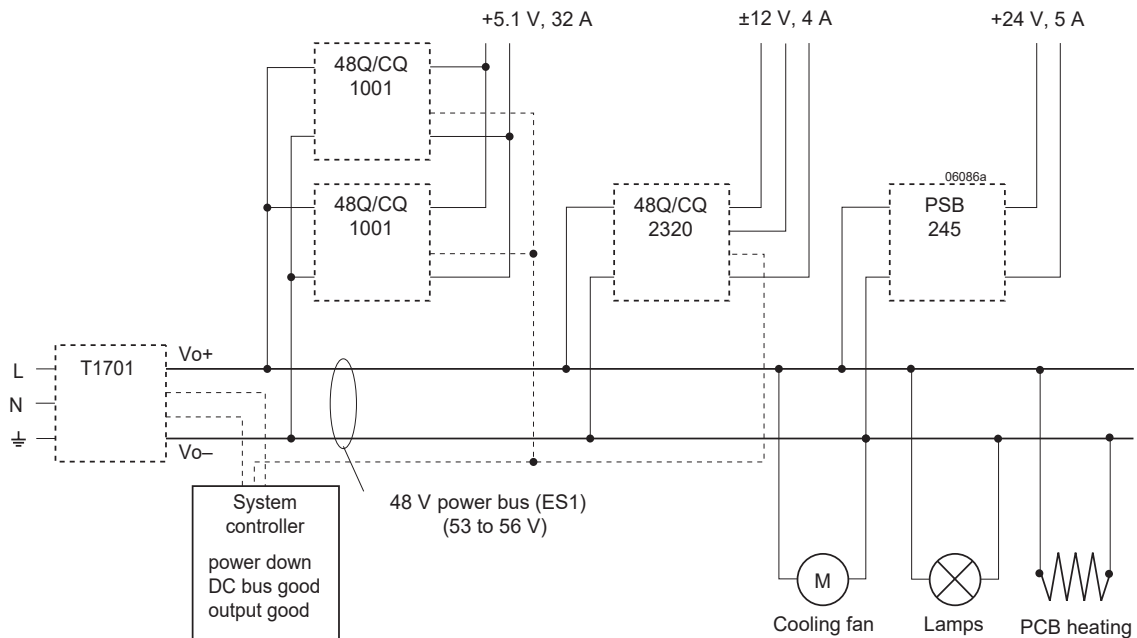

Fig. 39
Front end with various loads (example)

ELECTROMAGNETIC COMPATIBILITY (EMC)

A suppressor diode or a metal oxide VDR (depending on type) together with an input fuse and an input filter form an effective protection against input transient voltages, which typically occur in most installations, but especially in battery-driven mobile applications. The T Series has been successfully tested to the following specifications.

Electromagnetic Immunity

Table 15: Immunity type tests

Phenomenon	Standard	Level	Coupling mode ¹	Value applied	Waveform	Source imped.	Test procedure	In oper.	Perf. crit. ²
Electrostatic discharge (to case)	IEC/EN 61000-4-2	4	contact discharge	8000 V _p	1/50 ns	330 Ω 150 pF	10 pos. & 10 neg. discharges	yes	A
			air discharge	15000 V _p					
Electromagnetic field	IEC/EN 61000-4-3	3	antenna	10 V/m	AM 80% / 1 kHz	N/A	26 – 1000 MHz	yes	A
Electrical fast transients/burst	IEC/EN 61000-4-4	4	capacitive, o/c	±2000 V _p	bursts of 5/50 ns; 2.5/5 kHz over 15 ms; burst period: 300 ms	50 Ω	60 s positive 60 s negative transients per coupling mode	yes	A
		4	direct ± i/c, +i/-i	±4000 V _p					
Surges	IEC/EN 61000-4-5	3	± i/c	±2000 V _p	1.2 / 50 μs	12 Ω/9 μF 2 Ω/18 μF	5 pos. & 5 neg. surges per coupling mode	yes	B
			+i/-i	±1000 V _p					
Conducted disturbances	IEC/EN 61000-4-6	3	i, o, signal wires	10 VAC (140 dBμV)	AM 80% / 1 kHz	150 Ω	0.15 – 80 MHz	yes	A
Power frequency magnetic field	IEC/EN 61000-4-8			100 A/m			60 s in all 3 axis	yes	A

¹ i = input, o = output, c = case.

² A = Normal performance, B = Temporary loss of function or degradation of performance, not requiring an operator.

Electromagnetic Harmonics and Emission

The converters comply with the standards in table 16. For details see fig. 2, 3 and 4.

The radiated emissions between 30 MHz and 1 GHz on the input- and output-side comply with class A as per EN 55032.

The radiated emissions between 30 MHz and 1 GHz are reduced, if the converters are inserted in a 19" DIN-rack, fitted with front panels. For converters mounted otherwise, e.g. wall-mounted with option B1 (base plate), the radiated noise may exceed level A.

Table 16: Electromagnetic emissions

Phenomenon	Standards	Condition	Results
Harmonics	EN 61000-3-2:2006	V _i = 230 V, V _{o nom} , I _{o nom}	Class A, D
Voltage fluctuation and flicker	EN 61000-3-3 + A2:2005	V _i = 230 V, V _{o nom} , I _{o nom}	Complied

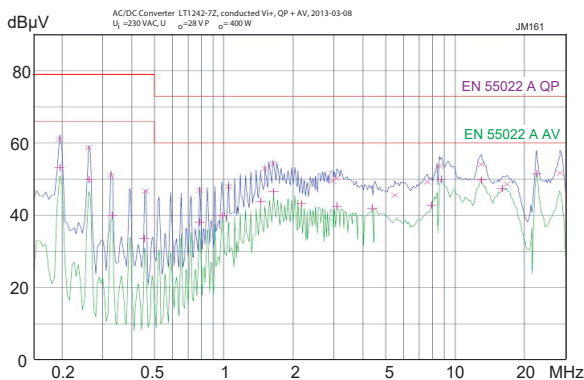

Fig. 40
Conducted emissions (quasi-peak, average) at the input, as per EN 55032, LT1242 (V_i = 230 V, V_o = 28 V, P_o = 400 W)

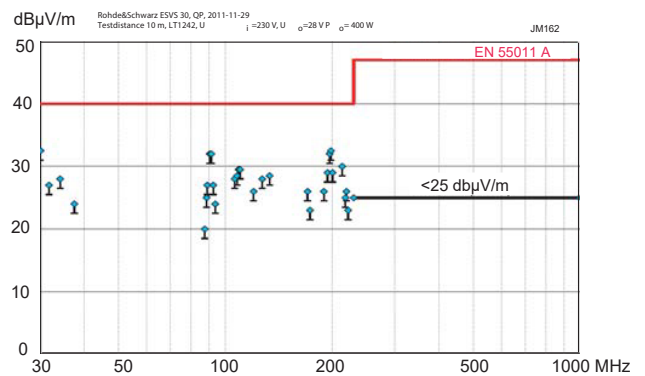

Fig. 41
Radiated emissions (quasi peak), as per EN 55032, distance 10 m, LT1242 (V_i = 230 V, V_o = 28 V, P_o = 400 W)

ENVIRONMENTAL CONDITIONS

Table 17: Mechanical and climatic stress.

Test method		Standard	Test Conditions	Status
Cab	Damp heat steady state	IEC/EN 60068-2-78	Temperature: 40 ±2 °C Relative humidity: 93 35 ^{+2/-3} % Duration: 56 days	Converter not operating
Ea	Shock (half-sinusoidal)	IEC/EN 60068-2-27	Acceleration amplitude: 100 g _n = 981 m/s ² Bump duration: 6 ms Number of bumps: 18 (3 each direction)	Converter operating
Fc	Vibration (sinusoidal)	IEC/EN 60068-2-6	Acceleration amplitude: 0.21 mm (10 – 60 Hz) 3 g _n = 29.4 m/s ² (60 – 2000 Hz) Frequency (1 Oct/min): 10 – 2000 Hz Test duration: 7.5 h (2.5 h each axis)	Converter operating
Fda	Random vibration wide band Reproducibility high	IEC/EN 60068-2-35 DIN 40046 part 23	Acceleration spectral density: 0.05 g _{n,rms} Frequency band: 20 – 500 Hz Acceleration magnitude: 4.9 g _{n,rms} Test duration: 3 h (1 h each axis)	Converter operating
Kb	Salt mist test sodium chloride (NaCl) solution	IEC/EN 60068-2-52	Concentration: 5% (30 °C) Duration: 2 h per cycle Storage: 40 °C, 93% rel. humidity Storage duration: 22 h per cycle Number of cycles: 3	Converter not operating

Temperatures

Table 18: Temperature specifications

Model		-7			Unit
Characteristics		Conditions	min	typ	max
T _A	Ambient operational temperature range	I _o = 0 – I _{o,nom}	- 25		70
		I _o > I _{o,nom}	- 25		65
T _C	Case temperature range at measurement point; see <i>Mechanical Data</i>	I _o = 0 – I _{o,nom}	- 25		95
		I _o > I _{o,nom}	- 25		90
T _S	Storage temperature range (not operating)		- 40		85
T _{Cs}	Case temperature, when shut down				100
R _{th,CA}	Thermal resistance case to ambient	convection cooling		0.5	K/W
t _c	Thermal time constant of case			1	h

Reliability

Table 19: MTBF

Values at specified case temperature	Model	Ground benign	Ground fixed		Ground mobile	Unit
		40°C	40°C	70°C	50°C	
MTBF ¹	LT1701-7	198 000	56 000	26 000	20 000	h
Device hours ²			810 000			

¹ Calculated in accordance with MIL-HDBK-217E (calculation accord. to edition F would show even better results)

² Statistical values, based on an average of 4300 working hours per year and in general field use, over 3 years

Thermal Considerations

Even though the T Series converters have a very high efficiency, the operating losses will heat the case. The two heat sinks are designed to dissipate the power losses at maximum output power over the specified temperature range without forced cooling, if the convection cooling provides sufficient air volume, without any obstruction for vertical air exchange below and above the converter.

Due to the slightly higher power losses in output power and current limitation mode, the maximum admissible ambient and case temperature is then lower than in output voltage regulation mode.

A built-in sensor disables the output in case of overtemperature. The converter automatically recovers, when the temperature falls below the limit.

Derating is required for applications with higher operational ambient temperature. The fig. below shows the derating of the output power versus operational temperature above the ambient temperature of 71 °C of an LT17xx unit. Two different conditions are shown:

a) Converter operating with convection cooling (solid line).

For example, if the operational ambient temperature reaches 80 °C, the output power should be limited to approx. 290 W. In this case steady operation in output power or current limitation mode is not possible.

b) Converter operating with forced cooling (dotted line).

Under these conditions, the case temperature T_C is decisive. With sufficient cooling provided (air flow!), the converter still delivers 550 Watts in voltage regulation mode even at $T_A = 85^\circ\text{C}$, provided that $T_C \leq 95^\circ\text{C}$ (T_C = measuring point of case temperature; see *Mechanical Data*). At $T_C \leq 90^\circ\text{C}$, steady operation in output power or current limitation mode is still possible. Nevertheless, it is not recommended to operate the converter continuously close to $T_{C\text{max}}$, since lifetime will be affected.

Since the operating temperature is of major importance to reliability, the following conditions should be observed:

Do not cover heat sinks.

42. Do not obstruct air flow around the heat sinks.

43. Maximize free space around the converter !

44. If the power supplies and the loads are located in the same enclosure, forced cooling is recommended.
The converters should be placed on the bottom of the enclosure.

45. Always check the maximum ambient and case temperature after system integration.

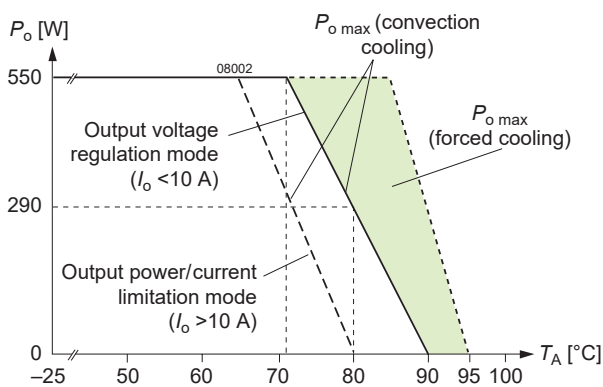

Fig. 46
Output power versus ambient temperature of LT17xx

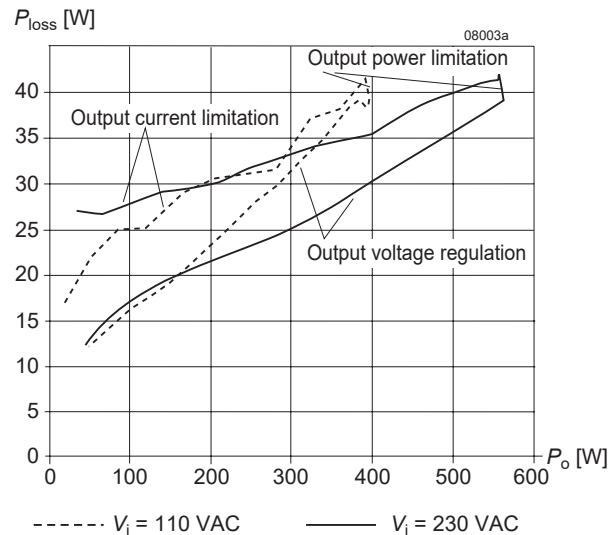

Fig. 47
Internal power losses versus nominal output power (LT17xx)

MECHANICAL DATA

Dimensions in mm. The converters are designed to be inserted into a 19" rack, 160 mm long, according to IEC 60297-3.

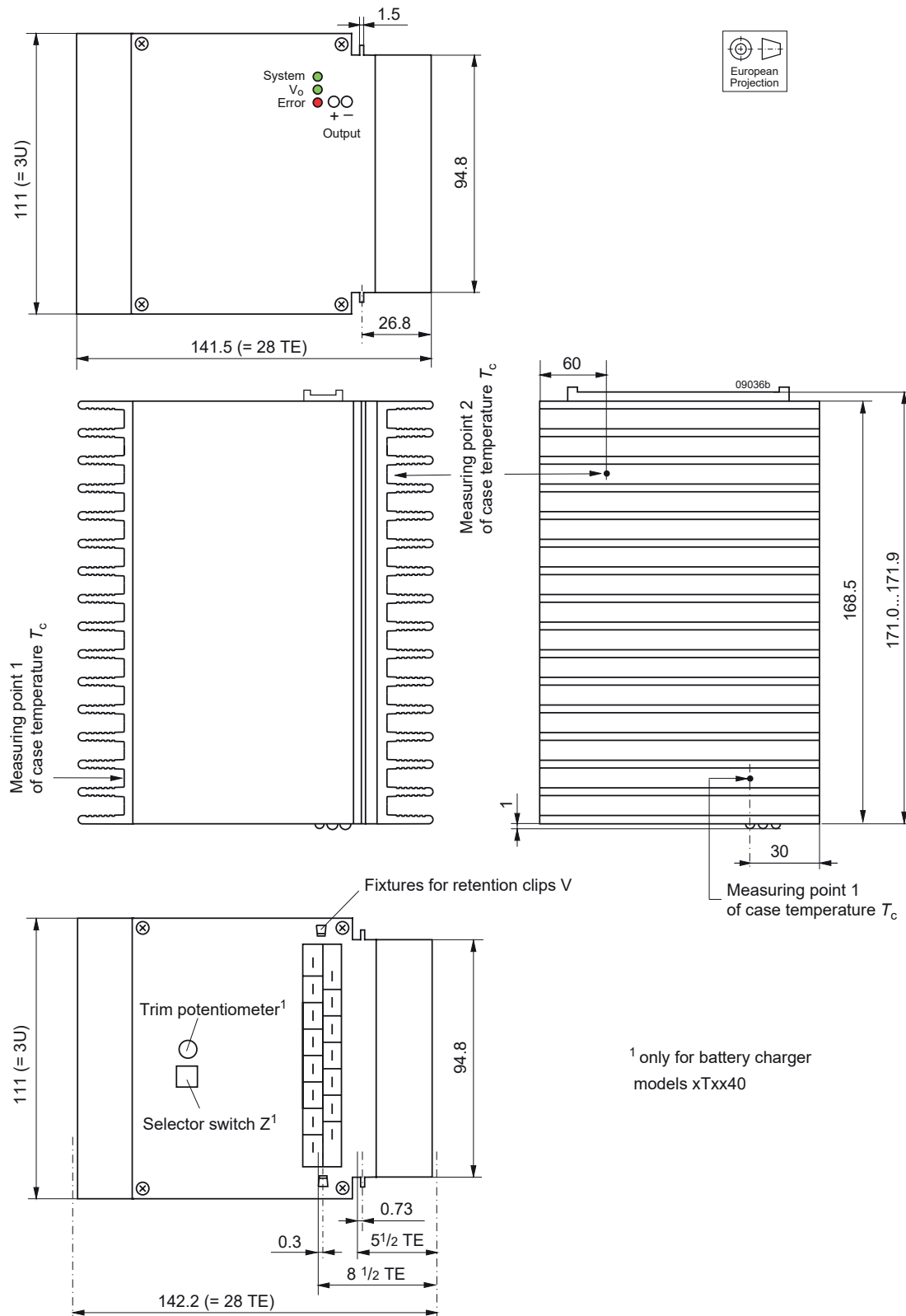

Fig. 48
Case T01, weight approx. 3 kg

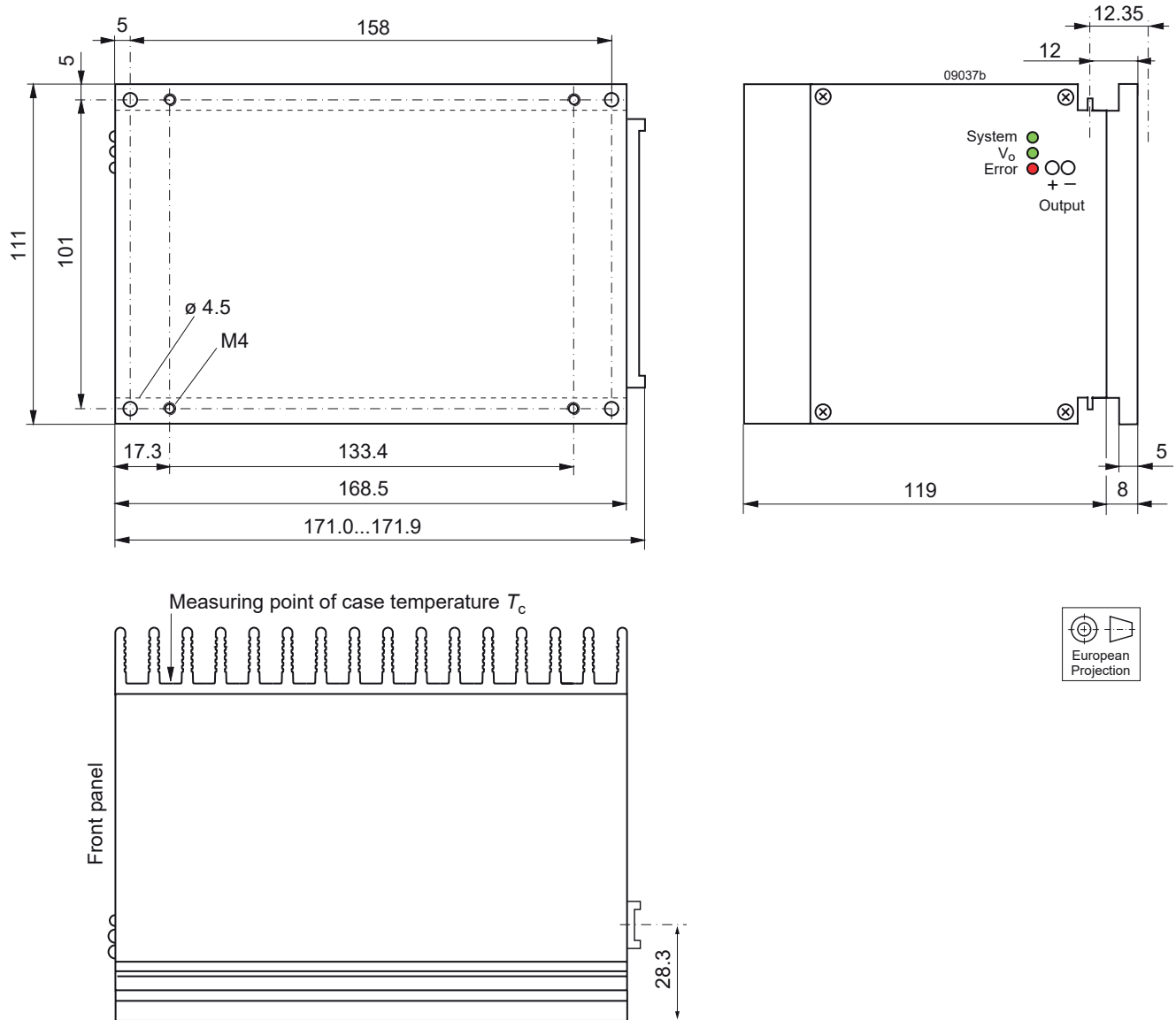

Fig. 49
Case T01 with option B1 (cooling plate)

SAFETY AND INSTALLATION INSTRUCTION

Connector Pin Allocation

The connector pin allocation table defines the electrical potentials and the physical pin positions at the H15 connector. Pin 8 and 10 (protective earth) are reliably connected to the case of the converter. They are leading pins, ensuring that they make contact with the female connector first.

Pin 16 (HC+) and pin 18 (HC-) are also leading pins to enable hot-swapping of the converter.

Table 20: Connector pin allocation

Pin	Electrical determination	Designation
4	Phase line input	L~
6	Neutral line input	N~
8 ¹	Protective earth PE ¹	
10 ¹	Protective earth PE ¹	
12	Output voltage positive	Vo+
14	Output voltage positive	Vo+
16 ¹	Hot plug-in contact positive	HC+
18 ¹	Hot plug-in contact negative	HC-
20	Output voltage negative	Vo-
22	Output voltage negative	Vo-
24	System Good signal input	Sys In
26	System Good signal output	Sys Out
28	Inhibit or remote control input	i/Vcr
30	Power Down signal	D
32	Power Down signal threshold of V_o	D set

¹ Leading pin (pre-connecting)

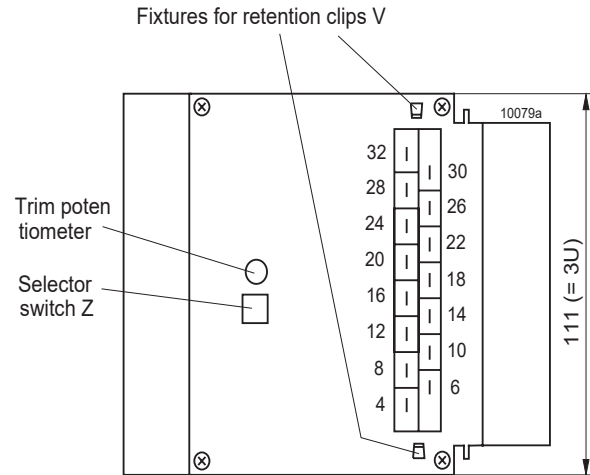

Fig. 50
H15 male connector

Installation Instruction

All T Series converters are components, intended exclusively for inclusion within other equipment by an industrial assembly operation or by professional installers. Installation must strictly follow the national safety regulations in compliance with the enclosure, mounting, creepage, clearance, casualty, markings, and segregation requirements of the end-use application.

Connection to the system shall be made via the female connector H15 (see *Accessories*). Other installation methods may not meet the safety requirements.

The converters are provided with pins 8 and 10 () , which are reliably connected to the case. For safety reasons it is essential to connect at least one of these pins reliably to the protective earth (PE) of the supply system.

Input L~ (pin 4) is internally fused. This fuse is designed to protect the converter in case of overcurrent and may not be able to satisfy all customer requirements. External fuses in the wiring to one or both inputs (pin 4 and/or pin 6) may therefore be necessary to ensure compliance with local requirements. A second fuse in the wiring to the neutral line N~ is needed, if:

- Local requirements demand an individual fuse in each source line
- Neutral to earth impedance is high or undefined
- Phase and neutral of the mains are not defined or cannot be assigned to the corresponding terminals (L~ to phase and N~ to neutral).

Important: Do not open the converter, or warranty will be invalidated.

Caution: Prior to handling, the converter must be disconnected from mains and from other sources (such as batteries).

Hazardous energy levels may be present at the output terminals for 3 minutes, even after the input voltage has been disconnected or switched off. This is indicated by the red error LED.

To prevent an unwanted short-circuit across the output of a disconnected converter, pins 16 and 18 are leading pins. In case of a short-circuit across the output of a T unit, all LEDs will be off, even though the mains may be present.

Due to high output current value, the T Series converters provide for each the positive and the negative output path two internally parallel connected contacts (pins 12/14 and pins 20/22). It is recommended to connect the load to both female connector pins of each path, in order to keep the voltage drop and power loss across the connector pins as small as possible.

If a T Series converter is used for battery charging, check whether the position of the cell voltage selector switch corresponds to the required battery cell voltage.

Caution: Lead-acid batteries can generate H₂ and O₂ gas, which can form explosive mixtures. Sufficient ventilation must be provided in battery cabinets and installation rooms.

Further information about designing battery systems is contained in VDE 0510, part 2.

If T Series converters are connected in parallel, it is recommended to connect the two hot plug-in pins of each female connector, HC+ (pin 16) and HC– (pin 18), to their respective output pins Vo+ and Vo–.

Make sure that there is sufficient air flow available for convection cooling. This should be verified by measuring the case temperature, when the converter is installed and operated in the end-use application. The maximum specified case temperature $T_{C_{max}}$ must not be exceeded. See also *Thermal Considerations*.

If the end-product is to be UL certified, the temperature test may be repeated as part of the end-product investigation.

Ensure that a converter failure (e.g., by an internal short-circuit) does not result in a hazardous condition. See also *Safety of Operator-Accessible Output*.

Protection Degree and Cleaning Liquids

If the female connector is fitted, the protection degree is IP30. Since the converters are not hermetically sealed, any penetration of cleaning fluids must be prevented.

Audible Noise

Under certain operating conditions, a T Series converter may generate a slight audible noise due to magnetostriction in the transformer. This noise does neither affect the function of the converter, nor is it detrimental to its performance over time.

Standards and Approvals

All T Series converters correspond to class I equipment. They comply with the latest issue of IEC/EN 62368-1. They are CE-marked and safety-approved by CSA and NEMKO. They have been evaluated for:

- Building in
- Basic insulation between input and case, based on 250 VAC
- Double or reinforced insulation between input and output, based on 250 VAC
- Operational insulation between output and case
- The use in a pollution degree 2 environment
- Connecting the input to a primary circuit with a maximum transient rating of 2500 V (overvoltage class III based on a 110 VAC primary circuit, overvoltage class II based on a 230 VAC primary circuit).

The converters are subject to manufacturing surveillance in accordance with the above mentioned standards and with ISO 9001.

Isolation

The electric strength test is performed in the factory as routine test in accordance with EN 62911 and IEC/EN 62368-1 and should not be repeated in the field. The Company will not honor any warranty claims resulting from incorrectly executed electric strength tests.

Table 21: Isolation

Characteristics		Input to Case & Output	Output to Case	Temp. Sensor T Output to Case	Unit
Electric strength test	Factory test >1 s	2.8 ¹	1.4	1.4	kVDC
	AC test voltage equivalent to factory test	2.0 ¹	1.0	1.0	kVAC
Insulation resistance at 500 VDC		>300	>300	>100	MW

¹ Subassemblies connecting input to output are pretested with 5.6 kVDC or 4.0 kVAC.

Touch Currents

Touch currents flow due to internal leakage capacitances and Y-capacitors. The current values are proportional to the supply voltage and are specified in the table below.

Table 22: Touch currents

Characteristics		Class I	Unit
Max. touch current	Permissible according to IEC/EN 62368-1	5.0	mA
	Typical value at 264 V, 60 Hz	2.0	

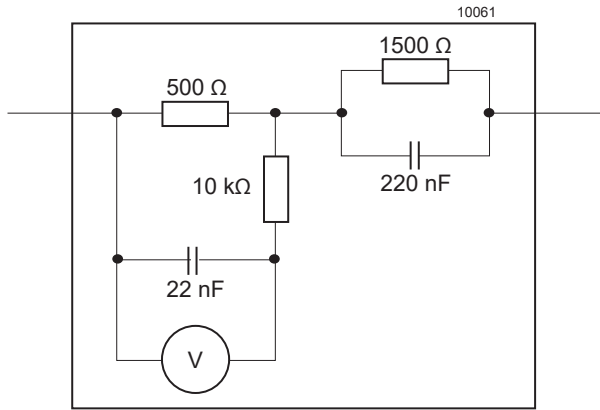

Fig. 51
Measuring instrument (MI) for earth leakage current test according to IEC/EN 62368-1, Annex D.

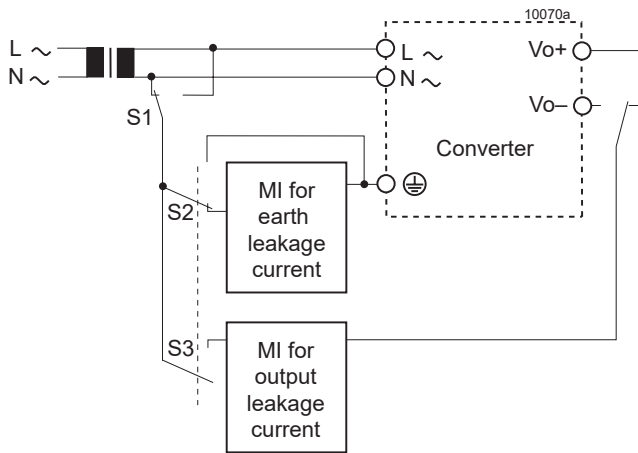

Fig. 52
Test set-up for leakage current in single phase configuration. S1 is used to simulate the interchanging of phase and neutral. S2, S3 select either the earth or output leakage current test, S4 selects either the positive or negative output.

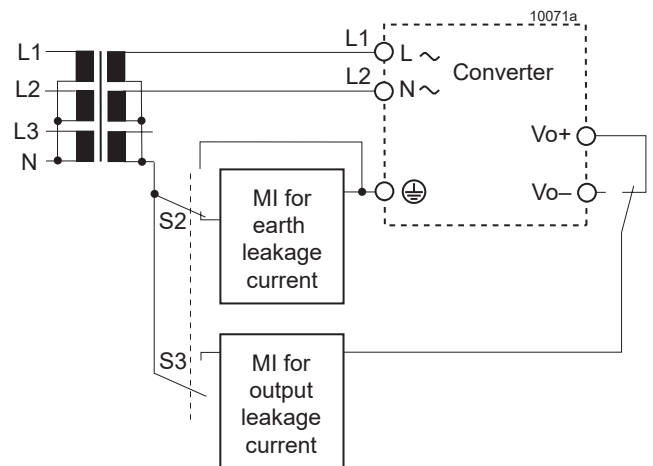

Fig. 53
Test set-up for leakage current in 208 V phase to phase configuration. S2, S3 select either the earth or output leakage current test, S4 selects either the positive or negative output.

Table 23: Leakage currents

Characteristics		LT / UT	Unit
Earth leakage current	Permissible according to IEC/EN 62368-1	3.5	mA
	Specified value at 255 V, 50 Hz (LT)	1.8 ¹	
	Specified value at 127 V, 60 Hz (LT or UT)	1.1 ¹	
Output leakage current	Permissible according to IEC/EN 62368-1	0.25	
	Specified value at 255 V, 50 Hz (LT)	< 0.1	
	Specified value at 127 V, 60 Hz (LT or UT)	< 0.1	

¹ In phase to phase configuration, the leakage current is lower.

Safety of Operator-Accessible Output Circuits

If the output circuit of a converter is operator-accessible, it shall be an ES1 according to the safety standard IEC/EN 62368-1.

The following table shows a possible installation configuration, compliance with which causes the output circuit to be an ES1 circuit up to a configured output voltage (sum of nominal voltages if in series or +/- configuration) of 56.5 V.

However, it is the sole responsibility of the installer to assure the compliance with the relevant and applicable safety regulations.

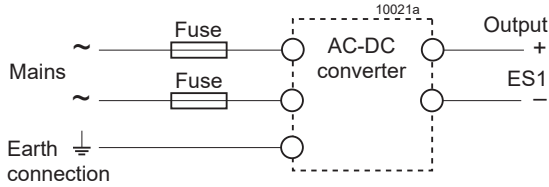

Fig. 54
Schematic safety concept

Table 24: Safety concept leading to an ES1 circuit

Conditions	AC-DC converter	Installation	Results
Supply voltage	Grade of isolation between input and output, provided by the AC-DC converter	Measures to achieve the resulting safety status of the output circuit	Safety status of the AC-DC converter output circuit
Mains ≤ 250 VAC	Double or reinforced	Installation according to the applicable standards	ES1 circuit

DESCRIPTION OF OPTIONS

D Undervoltage Monitor Adjust

This option is designed for systems using backplanes or is intended for use in applications, where a fuse or a decoupling diode is fitted into the positive supply line to the system bus. The status of the system bus/battery voltage can be monitored rather than the output status of a single T unit. Input D set (pin 32) is not internally connected to Vo+ (R_{int} is missing; see fig. 20).

To maintain the adjustment capabilities and resistor values for setting the different threshold values, a 43.2 kΩ (21.5 kΩ) resistor should be fitted into the sense line to the bus. If D set (pin 32) is left open, output D (pin 30) is permanently signaling low bus voltage.

For details see also *Auxiliary functions, Power Down*.

B1 Cooling Plate

If a cooling surface is available, the converters can be provided with a mounting plate (option B1) instead of the standard heat sink on the right-hand side; see *Mechanical Data*.

Since approximately 50% of the losses have to be dissipated through the remaining heat sink on the left-hand side, sufficient free air flow must still be provided.

Option G:

RoHS-compliant for all six substances.

ACCESSORIES

A variety of electrical and mechanical accessories are available.

T Series Front Panels 28 TE

These front panels fit to all T Series converters (case size T01).

Table 25: T case front panel selection

TE	Width mm	Case size	Part no.	HZZ no.
28	141.9	T01	G28-T01METSLEEVE	HZZ00890
28	141.9	T01	G28-T01	HZZ00837

Delivery content: G28-T01:

Front panel with 2 grey plastic handles, 3 countersunk screws, set of 4 plastic or metal retainers with captive screws, and assembly instructions.

G28-T01METSLEEVE [HZZ00890]: metal screw retainers;
G28-T01 [HZZ00837]: plastic screw retainers.

Blind plates: To close a non fully equipped 19" DIN-rack (only one or two converters fitted), 28 TE wide blind plates without holes are available:

G28-T01-BLANKMET [HZZ00847]: metal screw retainers,
G28-T01-BLANKPLAS [HZZ00848]: plastic screw retainers.

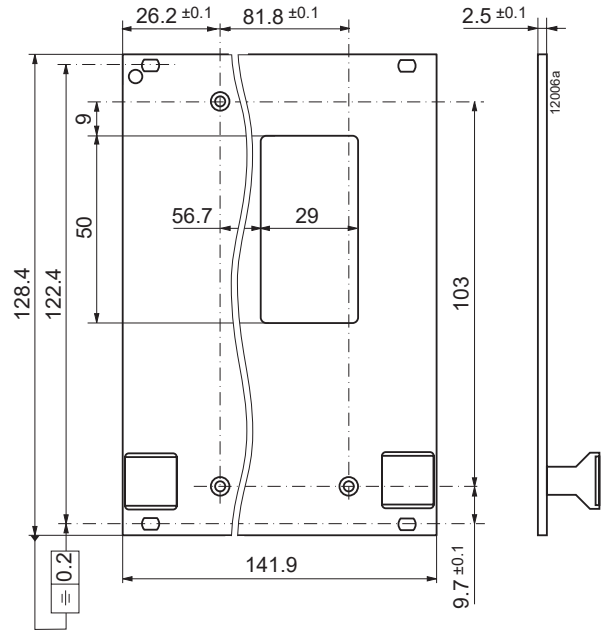

Fig. 55
Front panels for T Series (case T01)

Different female connectors are listed in the data sheet [Cassette Style Mating Connectors](#) on our website.

- Female H15 connectors with screw, solder, faston, or pressfit terminals
- Code key system for connector coding
- Connector retention clips and brackets
- Different cable hoods.



Fig. 56
H15 female connector (with code system)

19" DIN-rack systems are described in our data sheet [Front Panels and DIN-Racks](#)

- MQB02002 (Rittal)
- MQB02020G (Schroff, rugged version)



Fig. 57
19" DIN-rack

Backplanes for system integration matching 19" DIN-rails are described in [Backplanes BPD, BPF for T Series](#) data sheet.



Fig. 58
Backplane for system integration

Temperature Sensors T

The T Series battery chargers exhibit a cell voltage selector switch Z to set the required floating charge voltage at 20 °C directly at the converter. If this Z switch is used, the 2.23 V/cell sensor types should be selected in any case as a basis, and the selection criteria are only the temperature coefficient and the nominal voltage of the battery. For example, if a 24 V battery is used, which has a cell voltage of 2.23 V and a cell temperature coefficient of -3.5 mV/K, the sensor type is S24-2.23-35-02. The setting on the Z switch should be 2.23.

For T Series converters without Z selector switch, a sensor according to both criteria should be selected. In our example it should be S24-2.23-35-02.

The active temperature sensor T is of robust construction, mounted into a sealed aluminum tube of 12 mm outer diameter and 50mm length. The sensors are waterproof (IP 66) and high-voltage tested with 1.4 kVDC. Connection should be done via the colored 3 wire cable to the output of the converter (Vo+ and Vo-) and the remote control input i/Vcr (pin 28).

Caution: Wrong connection may damage the sensor and the converter.

Note: Battery specific sensors with cell voltages from 2.23 V up to 2.32 V and temperature coefficients from -2 up to -4.5 mV/K per cell or different cable lengths are available upon request.

Note: For installation of batteries, see VDE 510 as well as the recommendations of the battery manufacturers.

If sensors are connected in parallel (redundant configuration), they should be decoupled by 200 kΩ resistors; see fig. below. An individual sensor for each parallel connected T converter is not recommended, because current sharing is affected by the sensor tolerance.

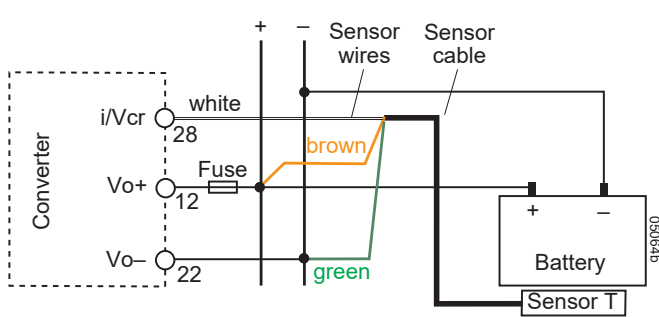

Fig. 59
Wiring diagram sensor

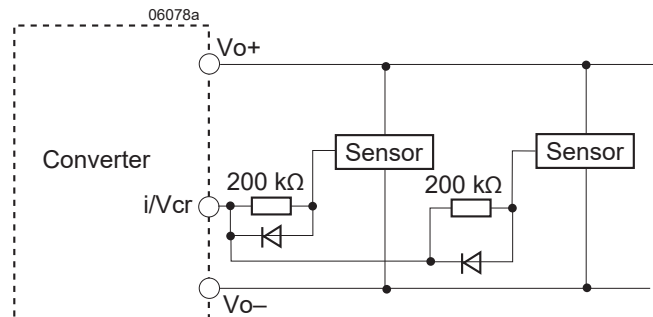

Fig. 60
Sensors connected in parallel.
Sensors in parallel provide redundant voltage adjustment in case of one of the sensors goes into an open-circuit or short-circuit condition (add. external components required)

Table 26: Type survey temperature sensors T

Sensor type	Nominal battery voltage [V]	Cell voltage [V]	Temp. coefficient per cell [mV/K]	Cable length [m]
S24-2.23-45-02	24	2.23	- 4.5	2
S36-2.23-30-02	36	2.23	- 3.0	2
S48-2.23-30-02	48	2.23	- 3.0	2
S48-2.23-35-02	48	2.23	- 3.5	2

Obsolete, no longer available.

Table 27: Sensor data

Characteristics		Conditions	min	typ	max	Unit
T_{Sensor}	Sensor temperature range	$V_{\text{cr}} = 5.5 - 11.5 \text{ V}$	- 10		60	°C
V_{cr}	Control voltage range	Absolute ratings	3.9		15	V
V_{cr}	Control voltage tolerance	$T_{\text{Sensor}} = 20 \text{ °C}$			±0.1	
		$T_{\text{Sensor}} = 0 - 53 \text{ °C}$			±0.2	

T Series

500 W AC-DC Converters



MELCHER™
The Power Partners.

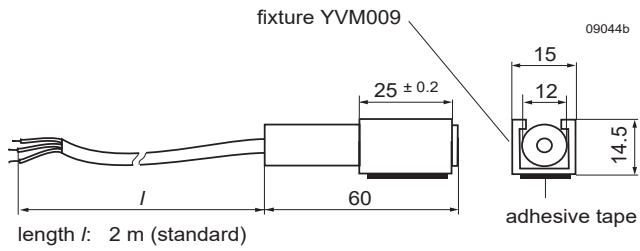

Fig. 61
Mechanical dimensions (in mm)



Fig. 62
Temperature sensor *T* with mounting fixture.

NUCLEAR AND MEDICAL APPLICATIONS - These products are not designed or intended for use as critical components in life support systems, equipment used in hazardous environments, or nuclear control systems.

TECHNICAL REVISIONS - The appearance of products, including safety agency certifications pictured on labels, may change depending on the date manufactured. Specifications are subject to change without notice.



Asia-Pacific
+86 755 298 85888

EMEA
+353 61 49 8941

North America
+1 866 513 2839

tech.support@psbel.com
belfuse.com/power-solutions

© 2023 Bel Fuse Inc.

BCD20023_AG

9 August 2023

Looking for pricing, stock, or lifecycle information?

Click below to explore more details on WIN SOURCE:

- [View UT1201-7G on WIN SOURCE](#)
- [Bel Power Solutions Information](#)

Optimize Your Supply Chain with WIN SOURCE Solutions

- ✓ Global Sourcing Solution
- ✓ Obsolete Management
- ✓ Cost Control Management
- ✓ Shortage Management
- ✓ Alternative Solution
- ✓ Excess Inventory Management