

SN74ALVCH16245 16-Bit Bus Transceiver With 3-State Outputs

1 Features

- Member of the Texas Instruments Widebus™ Family
- Operates From 1.65 V to 3.6 V
- Max t_{pd} of 3 ns at 3.3 V
- ± 24 -mA Output Drive at 3.3 V
- Bus Hold on Data Inputs Eliminates the Need for External Pullup or Pulldown Resistors
- Latch-Up Performance Exceeds 250 mA Per JESD 17
- ESD Protection Exceeds JESD 22
 - 2000-V Human-Body Model (A114-A)
 - 200-V Machine Model (A115-A)

2 Applications

- Cable Modem Termination Systems
- Servers
- LED Displays
- Network Switches
- Telecom Infrastructure
- Motor Drivers
- I/O Expanders

3 Description

This 16-bit (dual-octal) noninverting bus transceiver is designed for 1.65-V to 3.6-V V_{CC} operation.

The SN74ALVCH16245 device is designed for asynchronous communication between two data buses. The logic levels of the direction-control (DIR) input and the output-enable (\overline{OE}) input activate either the B-port outputs or the A-port outputs or place both output ports into the high-impedance mode. The device transmits data from the A bus to the B bus when the B-port outputs are activated, and from the B bus to the A bus when the A-port outputs are activated. The input circuitry on both A and B ports is always active and must have a logic high or low level applied to prevent excess I_{CC} and I_{CCZ} .

To ensure the high-impedance state during power up or power down, \overline{OE} should be tied to V_{CC} through a pullup resistor; the minimum value of the resistor is determined by the current-sinking capability of the driver.

Active bus-hold circuitry holds unused or undriven inputs at a valid logic state. Use of pullup or pulldown resistors with the bus-hold circuitry is not recommended.

Device Information⁽¹⁾

PART NUMBER	PACKAGE	BODY SIZE (NOM)
SN74ALVCH16245ZRD	BGA MICROSTAR JUNIOR (56)	4.50 mm × 7.00 mm
SN74ALVCH16245ZQL	BGA MICROSTAR JUNIOR (54)	5.50 mm × 8.00 mm
SN74ALVCH16245DGG	TSSOP (48)	6.10 mm × 12.50 mm
SN74ALVCH16245DGV	TVSOP (48)	4.40 mm × 9.70 mm
SN74ALVCH16245DL	SSOP (48)	7.50 mm × 15.80 mm

(1) For all available packages, see the orderable addendum at the end of the data sheet.

Logic Diagram (Positive Logic)

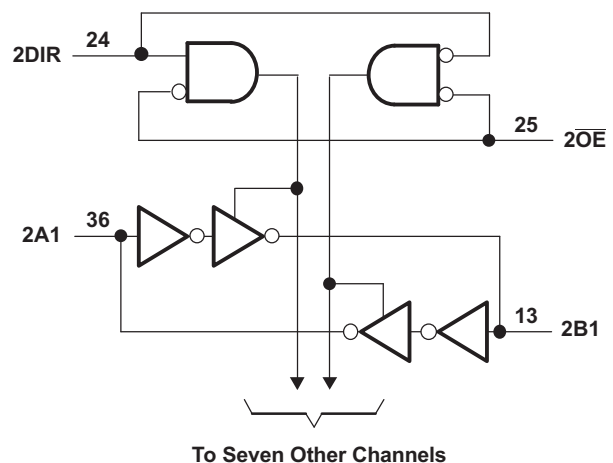
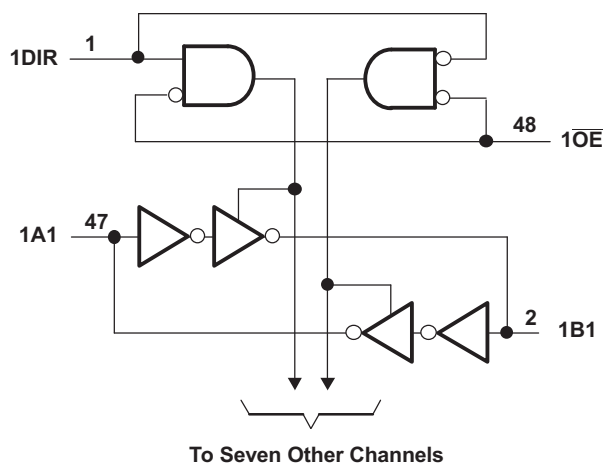

Table of Contents

<p>1 Features 1</p> <p>2 Applications 1</p> <p>3 Description 1</p> <p>4 Revision History 2</p> <p>5 Pin Configuration and Functions 3</p> <p>6 Specifications 6</p> <p style="padding-left: 20px;">6.1 Absolute Maximum Ratings 6</p> <p style="padding-left: 20px;">6.2 ESD Ratings 6</p> <p style="padding-left: 20px;">6.3 Recommended Operating Conditions 7</p> <p style="padding-left: 20px;">6.4 Thermal Information 7</p> <p style="padding-left: 20px;">6.5 Electrical Characteristics 8</p> <p style="padding-left: 20px;">6.6 Switching Characteristics 8</p> <p style="padding-left: 20px;">6.7 Operating Characteristics 8</p> <p style="padding-left: 20px;">6.8 Typical Characteristics 9</p> <p>7 Parameter Measurement Information 10</p> <p>8 Detailed Description 11</p> <p style="padding-left: 20px;">8.1 Overview 11</p>	<p style="padding-left: 20px;">8.2 Functional Block Diagrams 11</p> <p style="padding-left: 20px;">8.3 Feature Description 11</p> <p style="padding-left: 20px;">8.4 Device Functional Modes 11</p> <p>9 Application and Implementation 12</p> <p style="padding-left: 20px;">9.1 Application Information 12</p> <p style="padding-left: 20px;">9.2 Typical Application 12</p> <p>10 Power Supply Recommendations 13</p> <p>11 Layout 13</p> <p style="padding-left: 20px;">11.1 Layout Guidelines 13</p> <p style="padding-left: 20px;">11.2 Layout Example 13</p> <p>12 Device and Documentation Support 14</p> <p style="padding-left: 20px;">12.1 Community Resources 14</p> <p style="padding-left: 20px;">12.2 Trademarks 14</p> <p style="padding-left: 20px;">12.3 Electrostatic Discharge Caution 14</p> <p style="padding-left: 20px;">12.4 Glossary 14</p> <p>13 Mechanical, Packaging, and Orderable Information 14</p>
--	--

4 Revision History

NOTE: Page numbers for previous revisions may differ from page numbers in the current version.

Changes from Revision L (November 2005) to Revision M	Page
<ul style="list-style-type: none"> • Added ESD Rating table, Feature Description section, Device Functional Modes, Application and Implementation section, Power Supply Recommendations section, Layout section, Device and Documentation Support section, and Mechanical, Packaging, and Orderable Information section. 	1

5 Pin Configuration and Functions

**DGG, DGV, or DL Package
48-Pin TSSOP, TVSOP, or SSOP
Top View**

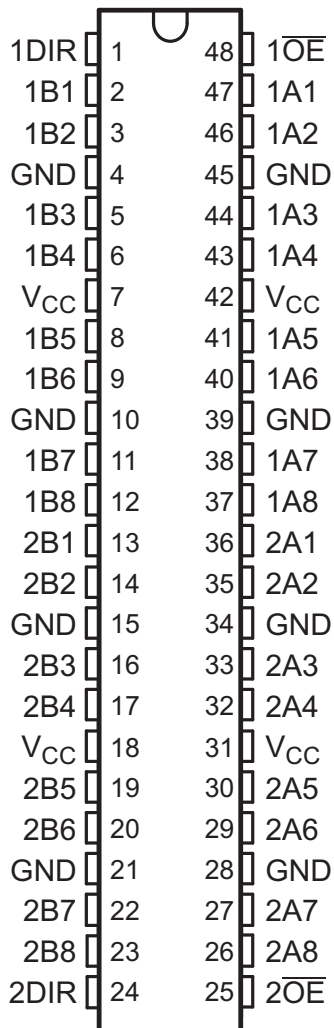

**GQL or ZQL Package
56-Pin BGA MICROSTAR JUNIOR
Top View**

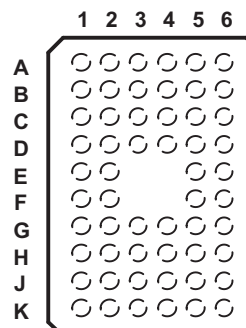

**GRD or ZRD Package
54-Pin BGA MICROSTAR JUNIOR
Top View**

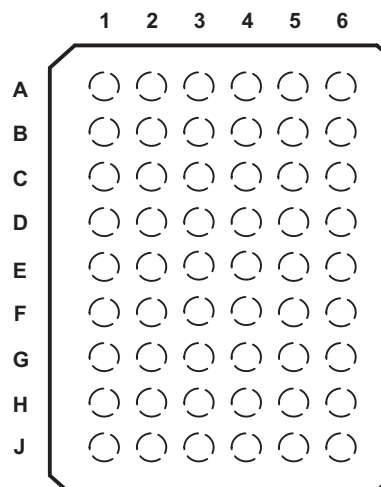

Pin Functions

NAME	PIN			I/O	DESCRIPTION
	TSSOP, TVSOP, SSOP	FBGA (56)	FBGA (54)		
1A1	47	B5	A6	I/O	Transceiver I/O pin
1A2	46	B6	B5	I/O	Transceiver I/O pin
1A3	44	C5	B6	I/O	Transceiver I/O pin
1A4	43	C6	C5	I/O	Transceiver I/O pin
1A5	41	D5	C6	I/O	Transceiver I/O pin
1A6	40	D6	D5	I/O	Transceiver I/O pin
1A7	38	E5	D6	I/O	Transceiver I/O pin
1A8	37	E6	E5	I/O	Transceiver I/O pin
2A1	36	F6	E6	I/O	Transceiver I/O pin
2A2	35	F5	F5	I/O	Transceiver I/O pin
2A3	33	G6	F6	I/O	Transceiver I/O pin

Pin Functions (continued)

NAME	PIN			I/O	DESCRIPTION
	TSSOP, TVSOP, SSOP	FBGA (56)	FBGA (54)		
2A4	32	G5	G5	I/O	Transceiver I/O pin
2A5	30	H6	G6	I/O	Transceiver I/O pin
2A6	29	H5	H5	I/O	Transceiver I/O pin
2A7	27	J6	H6	I/O	Transceiver I/O pin
2A8	26	J5	J6	I/O	Transceiver I/O pin
1DIR	1	A1	A3	I	Direction control. When high, the signal propagates from A to B. When low, the signal propagates from B to A.
$\overline{1OE}$	48	A6	A4	I	Output enable
2DIR	24	K1	J3	I	Direction control. When high, the signal propagates from A to B. When low, the signal propagates from B to A.
$\overline{2OE}$	25	K6	J4	I	Output enable
1B1	2	B2	A1	I/O	Transceiver I/O pin
1B2	3	B1	B2	I/O	Transceiver I/O pin
1B3	5	C2	B1	I/O	Transceiver I/O pin
1B4	6	C1	C2	I/O	Transceiver I/O pin
1B5	8	D2	C1	I/O	Transceiver I/O pin
1B6	9	D1	D2	I/O	Transceiver I/O pin
1B7	11	E2	D1	I/O	Transceiver I/O pin
1B8	12	E1	E2	I/O	Transceiver I/O pin
2B1	13	F1	E1	I/O	Transceiver I/O pin
2B2	14	F2	F2	I/O	Transceiver I/O pin
2B3	16	G1	F1	I/O	Transceiver I/O pin
B4	17	G2	G2	I/O	Transceiver I/O pin
2B5	19	H1	G1	I/O	Transceiver I/O pin
2B6	20	H2	H2	I/O	Transceiver I/O pin
2B7	22	J1	H1	I/O	Transceiver I/O pin
2B8	23	J2	J1	I/O	Transceiver I/O pin
GND	4,10,15,21,28,34,39,45	B3, B4, D3, D4, G3, G4, J3, J4	D3, D4, E3, E4, F3, F4	—	Ground
V _{CC}	7,18,31,42	C3, C4, H3, H4,	C3, C4, G3, G4	—	Power pin
NC	—	A2, A3, A4, A5, K2, K3, K4, K5	A2, A5, B3, B4, H3, H4, J2, J5	—	No connect

**Pin Assignments⁽¹⁾
(56-Ball GQL or ZQL Package)**

	1	2	3	4	5	6
A	1DIR	NC	NC	NC	NC	$\overline{1OE}$
B	1B2	1B1	GND	GND	1A1	1A2
C	1B4	1B3	V _{CC}	V _{CC}	1A3	1A4
D	1B6	1B5	GND	GND	1A5	1A6
E	1B8	1B7			1A7	1A8
F	2B1	2B2			2A2	2A1
G	2B3	2B4	GND	GND	2A4	2A3
H	2B5	2B6	V _{CC}	V _{CC}	2A6	2A5
J	2B7	2B8	GND	GND	2A8	2A7
K	2DIR	NC	NC	NC	NC	$\overline{2OE}$

(1) NC – No internal connection

**Pin Assignments ⁽¹⁾
(54-Ball GRD or ZRD Package)**

	1	2	3	4	5	6
A	1B1	NC	1DIR	$\overline{1OE}$	NC	1A1
B	1B3	1B2	NC	NC	1A2	1A3
C	1B5	1B4	V _{CC}	V _{CC}	1A4	1A5
D	1B7	1B6	GND	GND	1A6	1A7
E	2B1	1B8	GND	GND	1A8	2A1
F	2B3	2B2	GND	GND	2A2	2A3
G	2B5	2B4	V _{CC}	V _{CC}	2A4	2A5
H	2B7	2B6	NC	NC	2A6	2A7
J	2B8	NC	2DIR	$\overline{2OE}$	NC	2A8

(1) NC – No internal connection

6 Specifications

6.1 Absolute Maximum Ratings

over operating free-air temperature range (unless otherwise noted)⁽¹⁾

		MIN	MAX	UNIT
V_{CC}	Supply voltage	−0.5	4.6	V
V_I	Input voltage ⁽²⁾⁽³⁾	−0.5	$V_{CC} + 0.5$	V
V_O	Output voltage ⁽²⁾⁽³⁾	−0.5	$V_{CC} + 0.5$	V
I_{IK}	Input clamp current	$V_I < 0$	−50	mA
I_{OK}	Output clamp current	$V_O < 0$	−50	mA
I_O	Continuous output current		±50	mA
	Continuous current through each V_{CC} or GND		±100	mA
T_{stg}	Storage temperature	−65	150	°C

- (1) Stresses beyond those listed under *Absolute Maximum Ratings* may cause permanent damage to the device. These are stress ratings only, and functional operation of the device at these or any other conditions beyond those indicated under *Recommended Operating Conditions* is not implied. Exposure to absolute-maximum-rated conditions for extended periods may affect device reliability.
- (2) The input negative-voltage and output voltage ratings may be exceeded if the input and output current ratings are observed.
- (3) This value is limited to 4.6 V maximum.

6.2 ESD Ratings

		VALUE	UNIT
$V_{(ESD)}$	Electrostatic discharge	Human body model (HBM), per ANSI/ESDA/JEDEC JS-001, all pins ⁽¹⁾	2000
		Charged-device model (CDM), per JEDEC specification JESD22-C101, all pins ⁽²⁾	1000

- (1) JEDEC document JEP155 states that 500-V HBM allows safe manufacturing with a standard ESD control process.
- (2) JEDEC document JEP157 states that 250-V CDM allows safe manufacturing with a standard ESD control process.

6.3 Recommended Operating Conditions

 See ⁽¹⁾.

		MIN	MAX	UNIT
V _{CC}	Supply voltage	1.65	3.6	V
V _{IH}	High-level input voltage	V _{CC} = 1.65 V to 1.95 V	0.65 × V _{CC}	V
		V _{CC} = 2.3 V to 2.7 V	1.7	
		V _{CC} = 2.7 V to 3.6 V	2	
V _{IL}	Low-level input voltage	V _{CC} = 1.65 V to 1.95 V	0.35 × V _{CC}	V
		V _{CC} = 2.3 V to 2.7 V	0.7	
		V _{CC} = 2.7 V to 3.6 V	0.8	
V _I	Input voltage	0	V _{CC}	V
V _O	Output voltage	0	V _{CC}	V
I _{OH}	High-level output current	V _{CC} = 1.65 V	–4	mA
		V _{CC} = 2.3 V	–12	
		V _{CC} = 2.7 V	–12	
		V _{CC} = 3 V	–24	
I _{OL}	Low-level output current	V _{CC} = 1.65 V	4	mA
		V _{CC} = 2.3 V	12	
		V _{CC} = 2.7 V	12	
		V _{CC} = 3 V	24	
Δt/Δv	Input transition rise or fall rate		10	ns/V
T _A	Operating free-air temperature	–40	85	°C

(1) All unused control inputs of the device must be held at V_{CC} or GND to ensure proper device operation. Refer to the TI application report, *Implications of Slow or Floating CMOS Inputs*, [SCBA004](#).

6.4 Thermal Information⁽¹⁾

THERMAL METRIC ⁽¹⁾	SN74ALVCH16245					UNIT	
	DGG (TSSOP) ⁽²⁾	DGV (TVSOP) ⁽²⁾	DL (SSOP) ⁽²⁾	GQL/ZQL (BGA MICROSTAR JUNIOR) ⁽²⁾	GRD/ZRD (BGA MICROSTAR JUNIOR) ⁽²⁾		
	48 PINS	48 PINS	48 PINS	56 PINS	54 PINS		
R _{θJA}	Junction-to-ambient thermal resistance	70	58	63	42	36	°C/W

(1) For more information about traditional and new thermal metrics, see the *Semiconductor and IC Package Thermal Metrics* application report, [SPRA953](#).

(2) The package thermal impedance is calculated in accordance with JESD 51-7.

6.5 Electrical Characteristics

over recommended operating free-air temperature range (unless otherwise noted)

PARAMETER	TEST CONDITIONS	V _{CC}	MIN	TYP ⁽¹⁾	MAX	UNIT
V _{OH}	I _{OH} = –100 μA	1.65 V to 3.6 V	V _{CC} – 0.2			V
	I _{OH} = –4 mA	1.65 V	1.2			
	I _{OH} = –6 mA	2.3 V	2			
	I _{OH} = –12 mA	2.3 V	1.7			
		2.7 V	2.2			
		3 V	2.4			
I _{OH} = –24 mA	3 V	2				
V _{OL}	I _{OL} = 100 μA	1.65 V to 3.6 V	0.2			V
	I _{OL} = 4 mA	1.65 V	0.45			
	I _{OL} = 6 mA	2.3 V	0.4			
	I _{OL} = 12 mA	2.3 V	0.7			
		2.7 V	0.4			
	I _{OL} = 24 mA	3 V	0.55			
I _I	V _I = V _{CC} or GND	3.6 V	±5			μA
I _{I(hold)}	V _I = 0.58 V	1.65 V	25			μA
	V _I = 1.07 V	1.65 V	–25			
	V _I = 0.7 V	2.3 V	45			
	V _I = 1.7 V	2.3 V	–45			
	V _I = 0.8 V	3 V	75			
	V _I = 2 V	3 V	–75			
	V _I = 0 to 3.6 V ⁽²⁾	3.6 V	±500			
I _{OZ} ⁽³⁾	V _O = V _{CC} or GND	3.6 V	±10			μA
I _{CC}	V _I = V _{CC} or GND, I _O = 0	3.6 V	40			μA
ΔI _{CC}	One input at V _{CC} – 0.6 V, Other inputs at V _{CC} or GND	3 V to 3.6 V	750			μA
C _i Control inputs	V _I = V _{CC} or GND	3.3 V	4			pF
C _{io} A or B ports	V _O = V _{CC} or GND	3.3 V	8			pF

 (1) All typical values are at V_{CC} = 3.3 V, T_A = 25°C.

(2) This is the bus-hold maximum dynamic current. It is the minimum overdrive current required to switch the input from one state to another.

 (3) For I/O ports, the parameter I_{OZ} includes the input leakage current.

6.6 Switching Characteristics

over recommended operating free-air temperature range (unless otherwise noted) (see Figure 7)

PARAMETER	FROM (INPUT)	TO (OUTPUT)	V _{CC} = 1.8 V	V _{CC} = 2.5 V ± 0.2 V		V _{CC} = 2.7 V		V _{CC} = 3.3 V ± 0.3 V		UNIT
			TYP	MIN	MAX	MIN	MAX	MIN	MAX	
t _{pd}	A or B	B or A	See ⁽¹⁾	1	3.7	3.6		1	3	ns
t _{en}	\overline{OE}	A or B	See ⁽¹⁾	1	5.7	5.4		1	4.4	ns
t _{dis}	\overline{OE}	A or B	See ⁽¹⁾	1	5.2	4.6		1	4.1	ns

(1) This information was not available at the time of publication.

6.7 Operating Characteristics

 T_A = 25°C

PARAMETER	TEST CONDITIONS	V _{CC} = 1.8 V	V _{CC} = 2.5 V	V _{CC} = 3.3 V	UNIT
		TYP	TYP	TYP	
C _{pd} Power dissipation capacitance	Outputs enabled	See ⁽¹⁾	22	29	pF
	Outputs disabled	See ⁽¹⁾	4	5	

(1) This information was not available at the time of publication.

6.8 Typical Characteristics

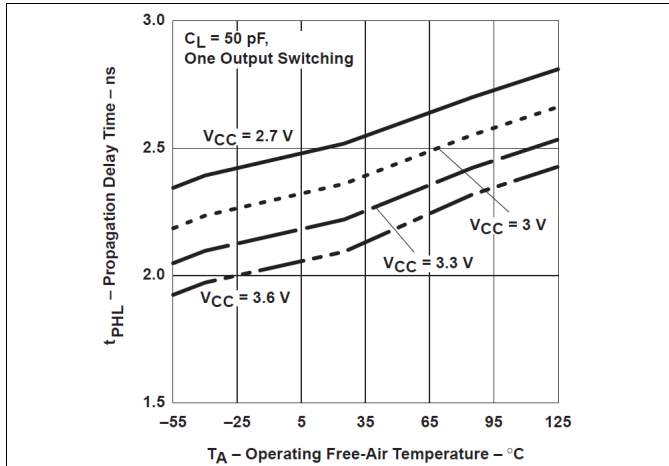

Figure 1. Propagation Delay Time vs Operating Free-Air Temperature

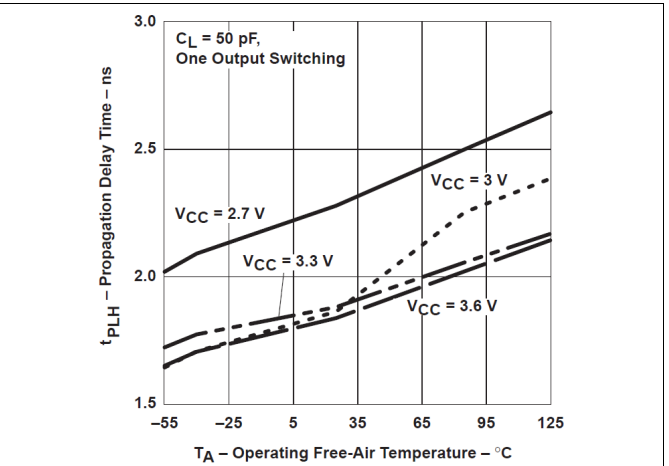

Figure 2. Propagation Delay Time vs Operating Free-Air Temperature

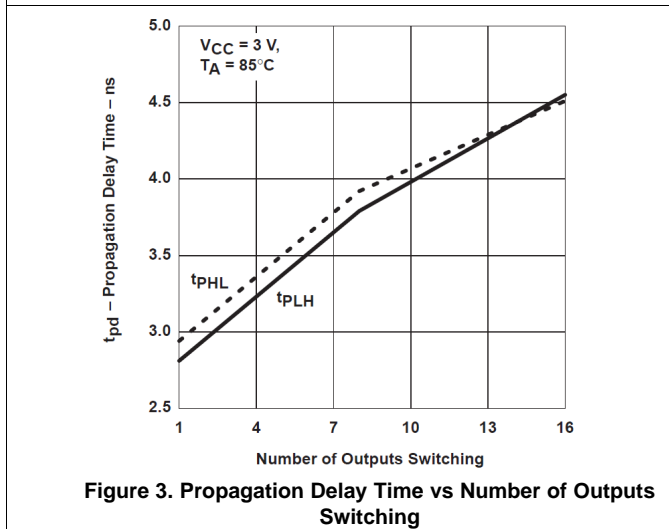

Figure 3. Propagation Delay Time vs Number of Outputs Switching

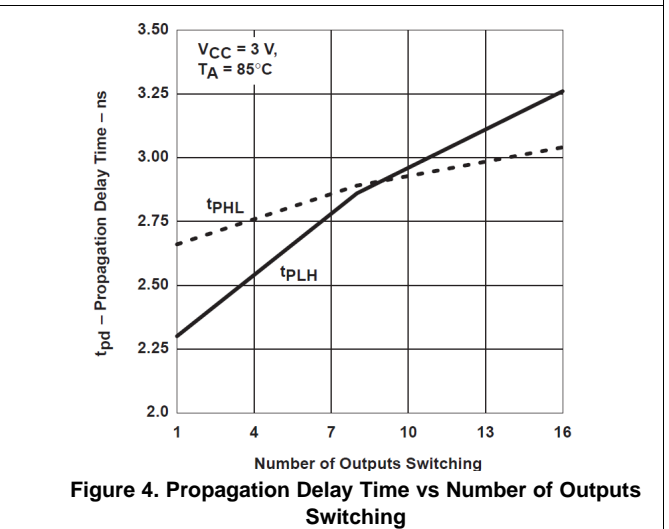

Figure 4. Propagation Delay Time vs Number of Outputs Switching

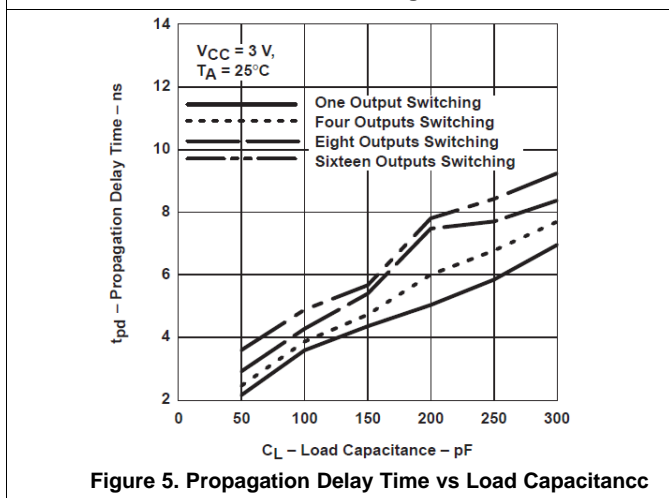

Figure 5. Propagation Delay Time vs Load Capacitance

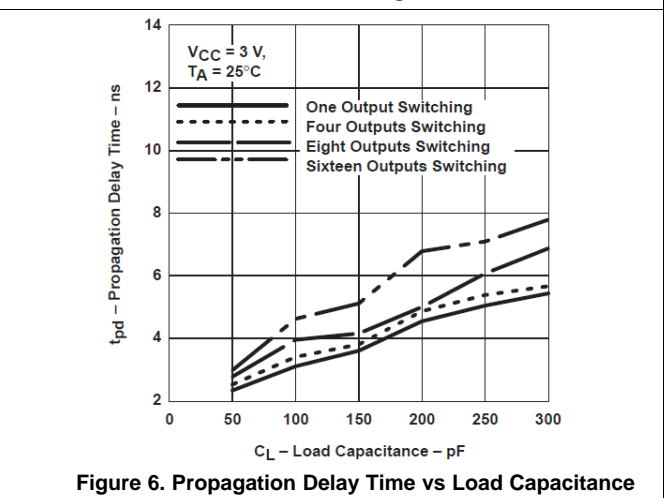
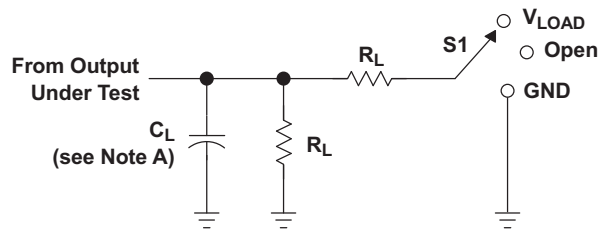

Figure 6. Propagation Delay Time vs Load Capacitance

7 Parameter Measurement Information

LOAD CIRCUIT

TEST	S1
t_{pd}	Open
t_{PLZ}/t_{PZL}	V_{LOAD}
t_{PHZ}/t_{PHL}	GND

V_{CC}	INPUT		V_M	V_{LOAD}	C_L	R_L	V_D
	V_I	t_r/t_f					
1.8 V	V_{CC}	≤ 2 ns	$V_{CC}/2$	$2 \times V_{CC}$	30 pF	1 k Ω	0.15 V
$2.5 \text{ V} \pm 0.2 \text{ V}$	V_{CC}	≤ 2 ns	$V_{CC}/2$	$2 \times V_{CC}$	30 pF	500 Ω	0.15 V
2.7 V	2.7 V	≤ 2.5 ns	1.5 V	6 V	50 pF	500 Ω	0.3 V
$3.3 \text{ V} \pm 0.3 \text{ V}$	2.7 V	≤ 2.5 ns	1.5 V	6 V	50 pF	500 Ω	0.3 V

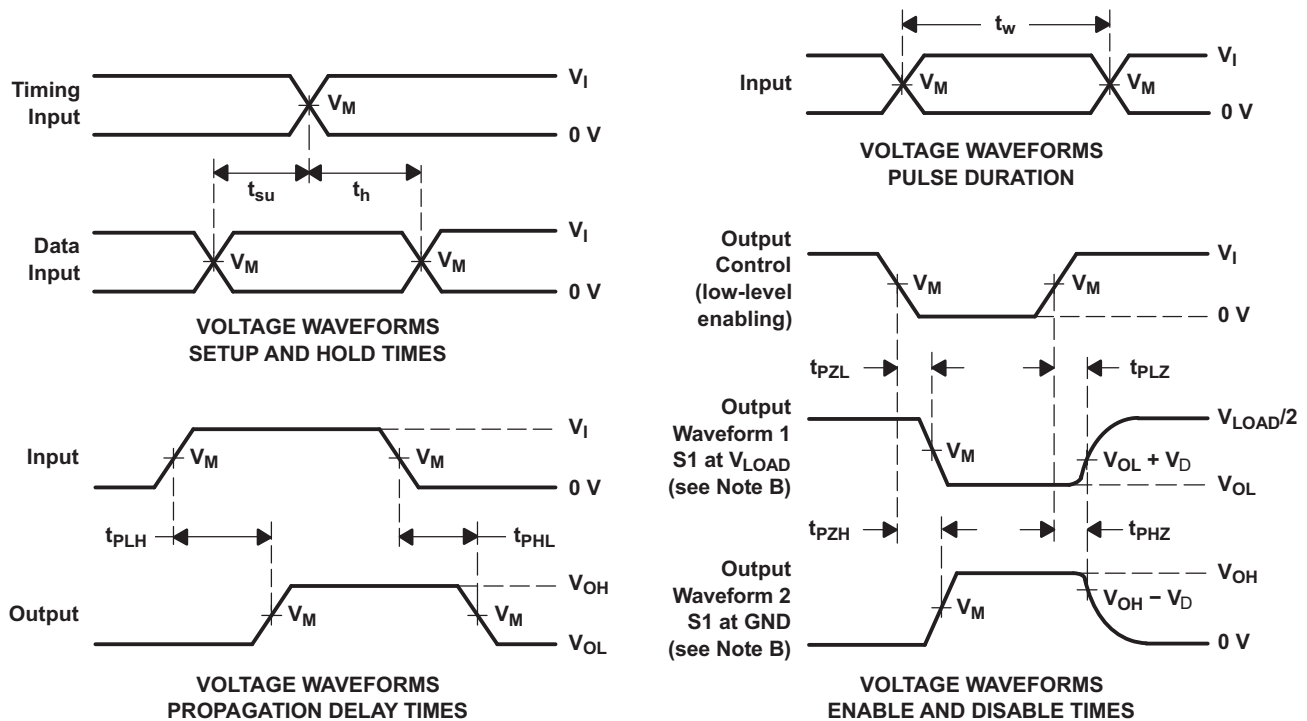

- NOTES:
- C_L includes probe and jig capacitance.
 - Waveform 1 is for an output with internal conditions such that the output is low except when disabled by the output control. Waveform 2 is for an output with internal conditions such that the output is high, except when disabled by the output control.
 - All input pulses are supplied by generators having the following characteristics: $PRR \leq 10$ MHz, $Z_O = 50 \Omega$.
 - The outputs are measured one at a time, with one transition per measurement.
 - t_{PLZ} and t_{PHZ} are the same as t_{dis} .
 - t_{PZL} and t_{PZH} are the same as t_{en} .
 - t_{PLH} and t_{PHL} are the same as t_{pd} .
 - All parameters and waveforms are not applicable to all devices.

Figure 7. Load Circuit and Voltage Waveforms

8 Detailed Description

8.1 Overview

The SN74ALVCH16245 device is designed for asynchronous communication between two data buses. The logic levels of the direction-control (DIR) input and the output-enable (\overline{OE}) input activate either the B-port outputs or the A-port outputs or place both output ports into the high-impedance mode. The device transmits data from the A bus to the B bus when the B-port outputs are activated, and from the B bus to the A bus when the A-port outputs are activated. The input circuitry on both A and B ports is always active and must have a logic high or low level applied to prevent excess I_{CC} and I_{CCZ} .

To ensure the high-impedance state during power up or power down, \overline{OE} should be tied to V_{CC} through a pullup resistor; the minimum value of the resistor is determined by the current-sinking capability of the driver.

Active bus-hold circuitry holds unused or undriven inputs at a valid logic state. Use of pullup or pulldown resistors with the bus-hold circuitry is not recommended.

8.2 Functional Block Diagrams

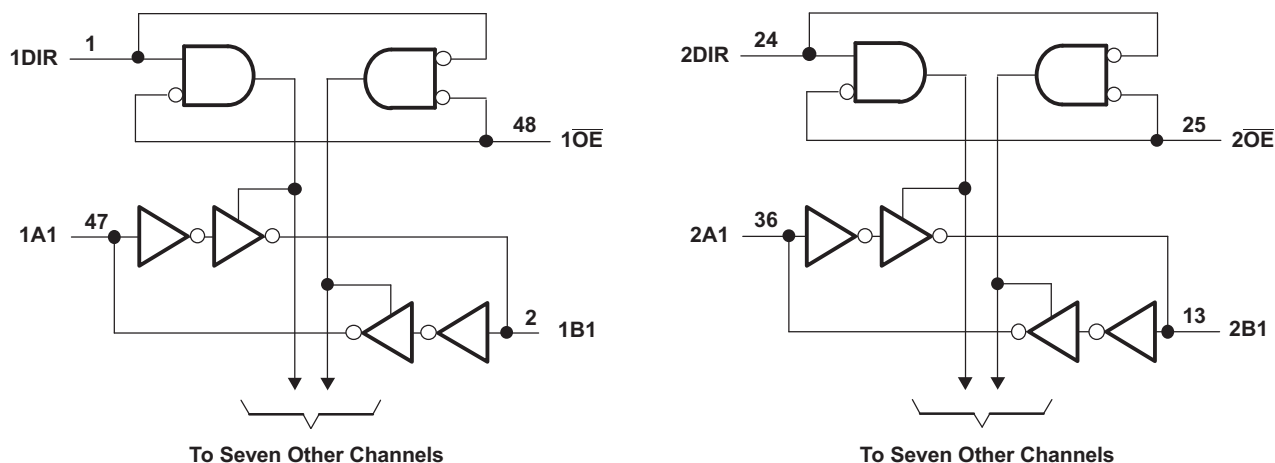

8.3 Feature Description

The input tolerance of 5.5V inputs allows the device to be used in down voltage translation applications as well for example if translation is required from 5 V to 3.3 V or 1.8 V. Also bus hold on data inputs eliminates the need for external pullup or pulldown resistors to be used, enabling customer to save board space and system cost.

8.4 Device Functional Modes

Table 1 lists the functional modes for SN74ALVCH16245.

Table 1. Function Table

INPUTS		OPERATION
\overline{OE}	DIR	
L	L	B data to A bus
L	H	A data to B bus
H	X	Isolation

9 Application and Implementation

NOTE

Information in the following applications sections is not part of the TI component specification, and TI does not warrant its accuracy or completeness. TI's customers are responsible for determining suitability of components for their purposes. Customers should validate and test their design implementation to confirm system functionality.

9.1 Application Information

SN74ALVCH16245A is a high-drive CMOS device that can be used for a multitude of bus interface type applications where output drive or PCB trace length is a concern. The inputs can accept voltages to 5.5 V at any valid V_{CC} making it ideal for down translation.

9.2 Typical Application

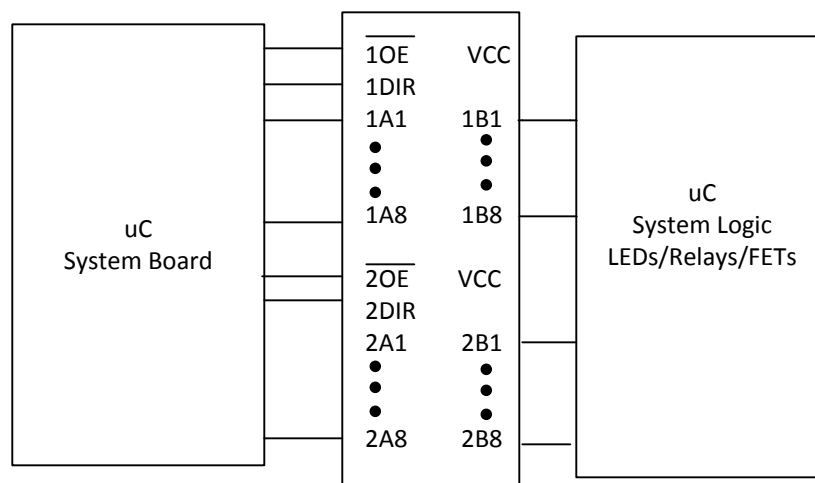

Figure 8. Typical Application Schematic

9.2.1 Design Requirements

This device uses CMOS technology and has balanced output drive. Take care to avoid bus contention because it can drive currents that would exceed maximum limits. The high drive will also create fast edges into light loads so routing and load conditions should be considered to prevent ringing.

9.2.2 Detailed Design Procedure

1. Recommended Input Conditions
 - For rise time and fall time specification, see [Switching Characteristics](#)
 - For specified high and low levels, see (V_{IH} and V_{IL}) in the [Electrical Characteristics](#) table.
 - Inputs are overvoltage tolerant allowing them to go as high as (V_I max) in the [Absolute Maximum Ratings](#) table at any valid V_{CC} .
2. Recommend Output Conditions
 - Load currents should not exceed (I_O max) per output and should not exceed (Continuous current through V_{CC} or GND) total current for the part. These limits are located in the [Recommended Operating Conditions](#) table.
 - Outputs should not be pulled above V_{CC} .

Typical Application (continued)

9.2.3 Application Curves

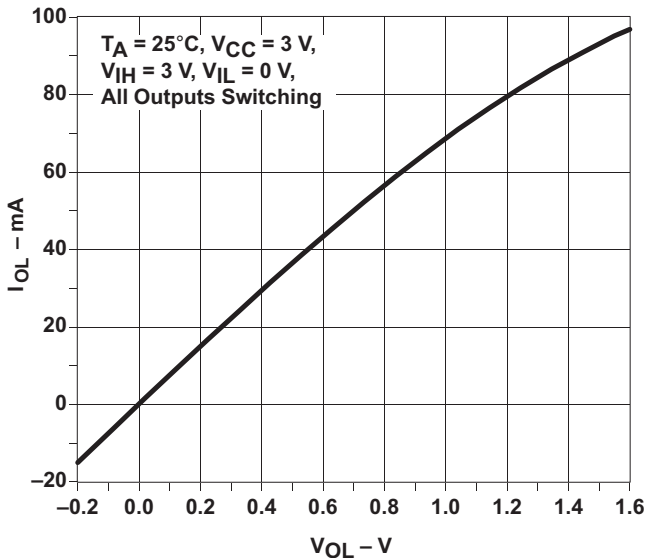

Figure 9. Output Drive Current (I_{OL}) vs LOW-level Output Voltage (V_{OL})

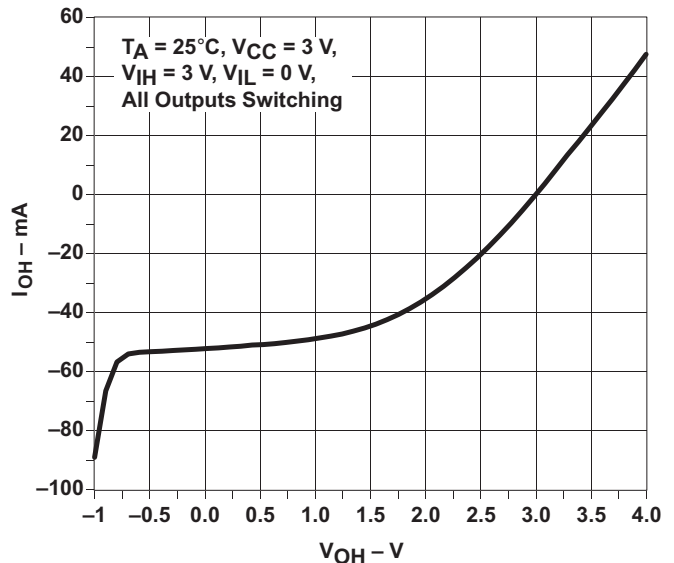

Figure 10. Output Drive Current (I_{OH}) vs HIGH-level Output Voltage (V_{OH})

10 Power Supply Recommendations

The power supply can be any voltage between the minimum and maximum supply voltage rating located in the [Absolute Maximum Ratings](#) table.

Each V_{CC} terminal should have a good bypass capacitor to prevent power disturbance. For devices with a single-supply, a 0.1- μF capacitor is recommended. If there are multiple V_{CC} terminals then 0.01- μF or 0.022- μF capacitors are recommended for each power terminal. It is ok to parallel multiple bypass capacitors to reject different frequencies of noise. Multiple bypass capacitors may be paralleled to reject different frequencies of noise. The bypass capacitor should be installed as close to the power terminal as possible for the best results.

11 Layout

11.1 Layout Guidelines

When using multiple bit logic devices, inputs should not float. In many cases, functions or parts of functions of digital logic devices are unused. Some examples are when only two inputs of a triple-input AND gate are used, or when only 3 of the 4-buffer gates are used. Such input pins should not be left unconnected because the undefined voltages at the outside connections result in undefined operational states.

Specified in [Figure 11](#) are rules that must be observed under all circumstances. All unused inputs of digital logic devices must be connected to a high or low bias to prevent them from floating. The logic level that should be applied to any particular unused input depends on the function of the device. Generally they will be tied to GND or V_{CC} , whichever makes more sense or is more convenient.

11.2 Layout Example

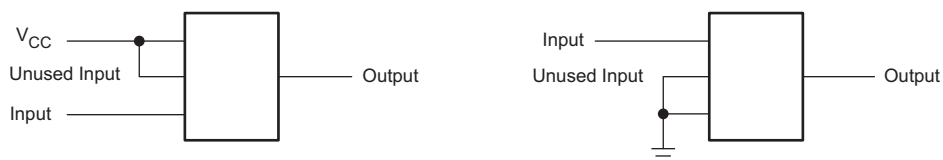

Figure 11. Layout Diagram

12 Device and Documentation Support

12.1 Community Resources

The following links connect to TI community resources. Linked contents are provided "AS IS" by the respective contributors. They do not constitute TI specifications and do not necessarily reflect TI's views; see TI's [Terms of Use](#).

TI E2E™ Online Community *TI's Engineer-to-Engineer (E2E) Community*. Created to foster collaboration among engineers. At e2e.ti.com, you can ask questions, share knowledge, explore ideas and help solve problems with fellow engineers.

Design Support *TI's Design Support* Quickly find helpful E2E forums along with design support tools and contact information for technical support.

12.2 Trademarks

Widebus, E2E are trademarks of Texas Instruments.
All other trademarks are the property of their respective owners.

12.3 Electrostatic Discharge Caution



These devices have limited built-in ESD protection. The leads should be shorted together or the device placed in conductive foam during storage or handling to prevent electrostatic damage to the MOS gates.

12.4 Glossary

[SLYZ022](#) — *TI Glossary*.

This glossary lists and explains terms, acronyms, and definitions.

13 Mechanical, Packaging, and Orderable Information

The following pages include mechanical, packaging, and orderable information. This information is the most current data available for the designated devices. This data is subject to change without notice and revision of this document. For browser-based versions of this data sheet, refer to the left-hand navigation.

PACKAGING INFORMATION

Orderable Device	Status (1)	Package Type	Package Drawing	Pins	Package Qty	Eco Plan (2)	Lead finish/ Ball material (6)	MSL Peak Temp (3)	Op Temp (°C)	Device Marking (4/5)	Samples
74ALVCH16245DGGRG4	ACTIVE	TSSOP	DGG	48	2000	RoHS & Green	NIPDAU	Level-1-260C-UNLIM	-40 to 85	ALVCH16245	Samples
SN74ALVCH16245DGGR	ACTIVE	TSSOP	DGG	48	2000	RoHS & Green	NIPDAU	Level-1-260C-UNLIM	-40 to 85	ALVCH16245	Samples
SN74ALVCH16245DGVR	ACTIVE	TVSOP	DGV	48	2000	RoHS & Green	NIPDAU	Level-1-260C-UNLIM	-40 to 85	VH245	Samples
SN74ALVCH16245DL	ACTIVE	SSOP	DL	48	25	RoHS & Green	NIPDAU	Level-1-260C-UNLIM	-40 to 85	ALVCH16245	Samples
SN74ALVCH16245DLR	ACTIVE	SSOP	DL	48	1000	RoHS & Green	NIPDAU	Level-1-260C-UNLIM	-40 to 85	ALVCH16245	Samples

(1) The marketing status values are defined as follows:

ACTIVE: Product device recommended for new designs.

LIFEBUY: TI has announced that the device will be discontinued, and a lifetime-buy period is in effect.

NRND: Not recommended for new designs. Device is in production to support existing customers, but TI does not recommend using this part in a new design.

PREVIEW: Device has been announced but is not in production. Samples may or may not be available.

OBSOLETE: TI has discontinued the production of the device.

(2) **RoHS:** TI defines "RoHS" to mean semiconductor products that are compliant with the current EU RoHS requirements for all 10 RoHS substances, including the requirement that RoHS substance do not exceed 0.1% by weight in homogeneous materials. Where designed to be soldered at high temperatures, "RoHS" products are suitable for use in specified lead-free processes. TI may reference these types of products as "Pb-Free".

RoHS Exempt: TI defines "RoHS Exempt" to mean products that contain lead but are compliant with EU RoHS pursuant to a specific EU RoHS exemption.

Green: TI defines "Green" to mean the content of Chlorine (Cl) and Bromine (Br) based flame retardants meet JS709B low halogen requirements of <=1000ppm threshold. Antimony trioxide based flame retardants must also meet the <=1000ppm threshold requirement.

(3) MSL, Peak Temp. - The Moisture Sensitivity Level rating according to the JEDEC industry standard classifications, and peak solder temperature.

(4) There may be additional marking, which relates to the logo, the lot trace code information, or the environmental category on the device.

(5) Multiple Device Markings will be inside parentheses. Only one Device Marking contained in parentheses and separated by a "~" will appear on a device. If a line is indented then it is a continuation of the previous line and the two combined represent the entire Device Marking for that device.

(6) Lead finish/Ball material - Orderable Devices may have multiple material finish options. Finish options are separated by a vertical ruled line. Lead finish/Ball material values may wrap to two lines if the finish value exceeds the maximum column width.

Important Information and Disclaimer: The information provided on this page represents TI's knowledge and belief as of the date that it is provided. TI bases its knowledge and belief on information provided by third parties, and makes no representation or warranty as to the accuracy of such information. Efforts are underway to better integrate information from third parties. TI has taken and continues to take reasonable steps to provide representative and accurate information but may not have conducted destructive testing or chemical analysis on incoming materials and chemicals. TI and TI suppliers consider certain information to be proprietary, and thus CAS numbers and other limited information may not be available for release.

In no event shall TI's liability arising out of such information exceed the total purchase price of the TI part(s) at issue in this document sold by TI to Customer on an annual basis.

OTHER QUALIFIED VERSIONS OF SN74ALVCH16245 :

- Enhanced Product: [SN74ALVCH16245-EP](#)

NOTE: Qualified Version Definitions:

- Enhanced Product - Supports Defense, Aerospace and Medical Applications

TAPE AND REEL INFORMATION

QUADRANT ASSIGNMENTS FOR PIN 1 ORIENTATION IN TAPE



*All dimensions are nominal

Device	Package Type	Package Drawing	Pins	SPQ	Reel Diameter (mm)	Reel Width W1 (mm)	A0 (mm)	B0 (mm)	K0 (mm)	P1 (mm)	W (mm)	Pin1 Quadrant
SN74ALVCH16245DGGR	TSSOP	DGG	48	2000	330.0	24.4	8.6	13.0	1.8	12.0	24.0	Q1
SN74ALVCH16245DGVR	TVSOP	DGV	48	2000	330.0	16.4	7.1	10.2	1.6	12.0	16.0	Q1
SN74ALVCH16245DLR	SSOP	DL	48	1000	330.0	32.4	11.35	16.2	3.1	16.0	32.0	Q1

TAPE AND REEL BOX DIMENSIONS

*All dimensions are nominal

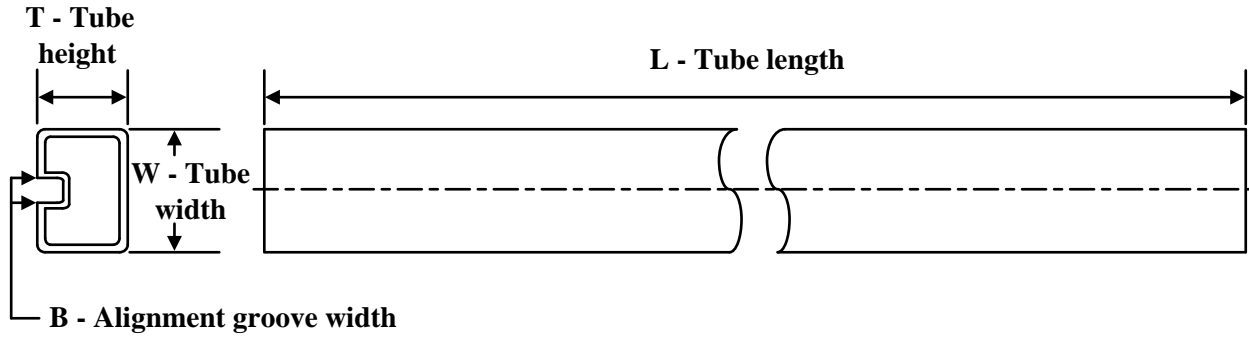
Device	Package Type	Package Drawing	Pins	SPQ	Length (mm)	Width (mm)	Height (mm)
SN74ALVCH16245DGGR	TSSOP	DGG	48	2000	367.0	367.0	45.0
SN74ALVCH16245DGVR	TVSOP	DGV	48	2000	356.0	356.0	35.0
SN74ALVCH16245DLR	SSOP	DL	48	1000	367.0	367.0	55.0

TUBE

*All dimensions are nominal

Device	Package Name	Package Type	Pins	SPQ	L (mm)	W (mm)	T (μm)	B (mm)
SN74ALVCH16245DL	DL	SSOP	48	25	473.7	14.24	5110	7.87

MECHANICAL DATA

DL (R-PDSO-G48)

PLASTIC SMALL-OUTLINE PACKAGE



- NOTES:
- All linear dimensions are in inches (millimeters).
 - This drawing is subject to change without notice.
 - Body dimensions do not include mold flash or protrusion not to exceed 0.006 (0,15).
 - Falls within JEDEC MO-118

PowerPAD is a trademark of Texas Instruments.

DGV (R-PDSO-G**)

PLASTIC SMALL-OUTLINE

24 PINS SHOWN

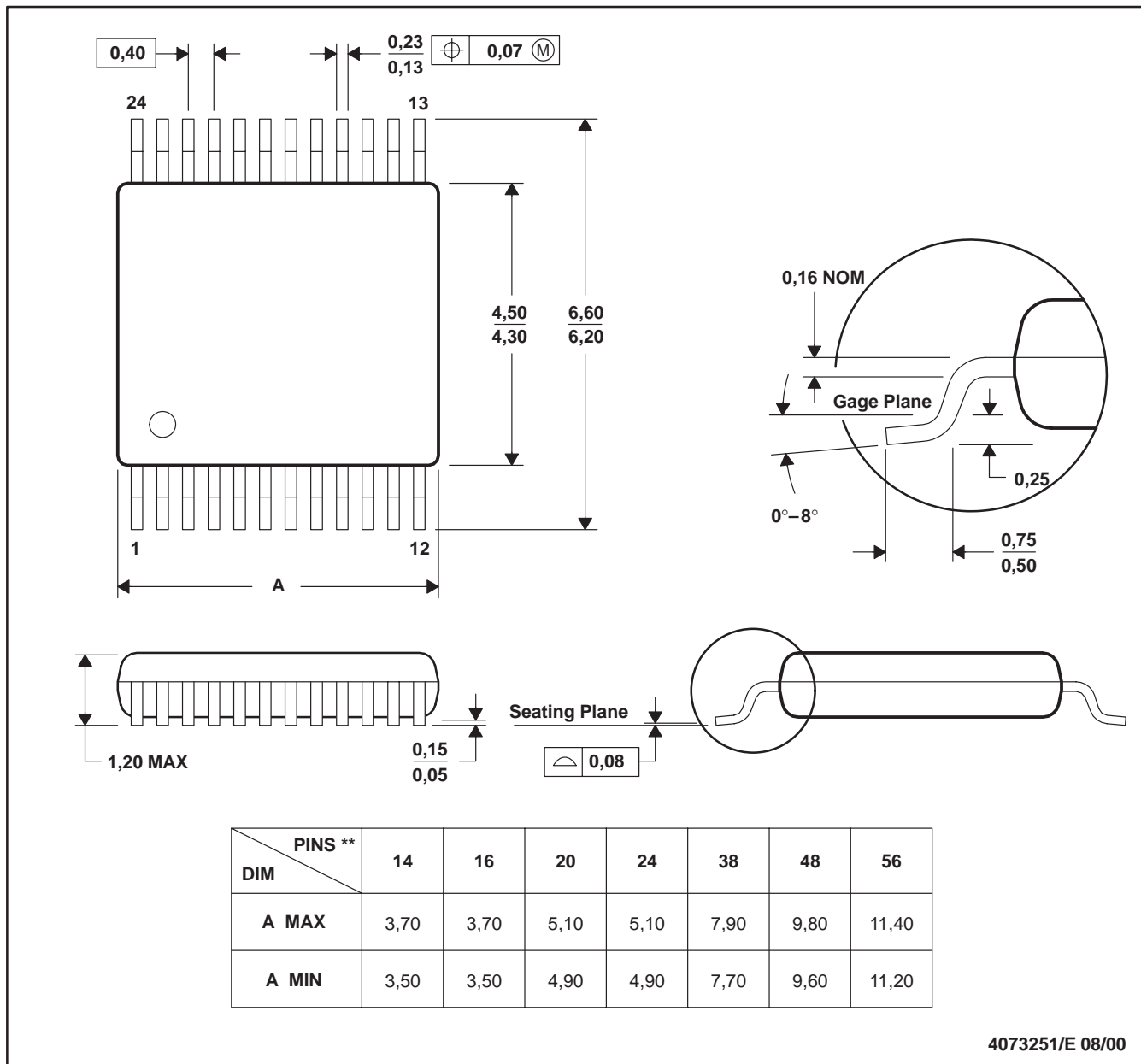

- NOTES: A. All linear dimensions are in millimeters.
 B. This drawing is subject to change without notice.
 C. Body dimensions do not include mold flash or protrusion, not to exceed 0,15 per side.
 D. Falls within JEDEC: 24/48 Pins – MO-153
 14/16/20/56 Pins – MO-194

EXAMPLE BOARD LAYOUT

DGG0048A

TSSOP - 1.2 mm max height

SMALL OUTLINE PACKAGE

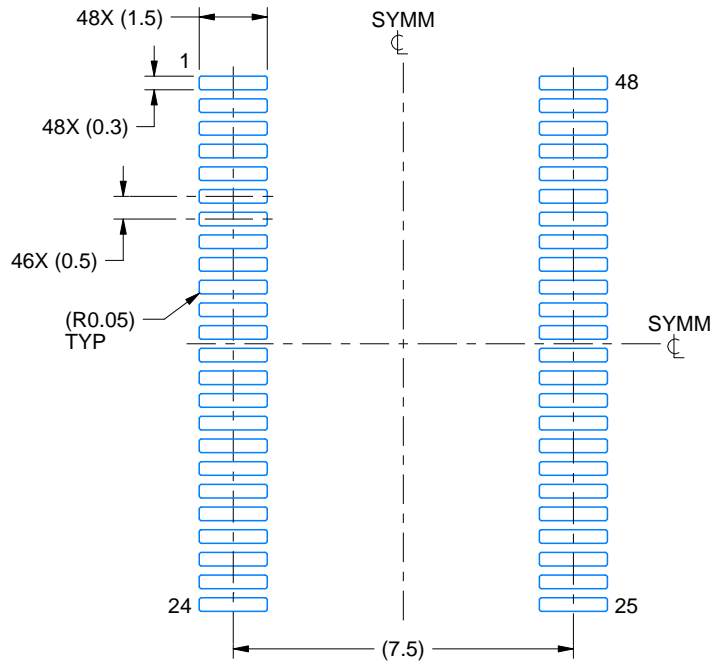

LAND PATTERN EXAMPLE
SCALE:6X

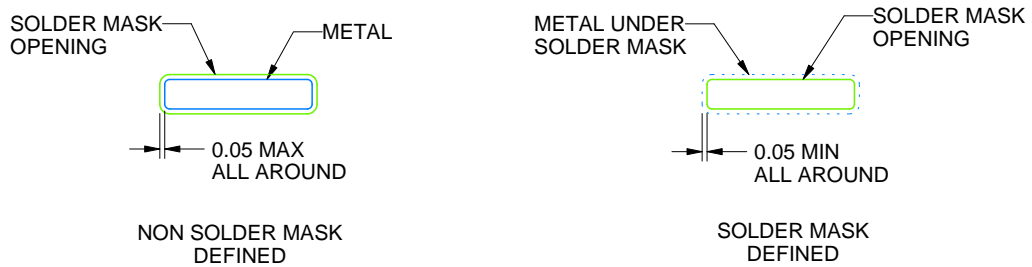

SOLDER MASK DETAILS

4214859/B 11/2020

NOTES: (continued)

5. Publication IPC-7351 may have alternate designs.
6. Solder mask tolerances between and around signal pads can vary based on board fabrication site.

EXAMPLE STENCIL DESIGN

DGG0048A

TSSOP - 1.2 mm max height

SMALL OUTLINE PACKAGE

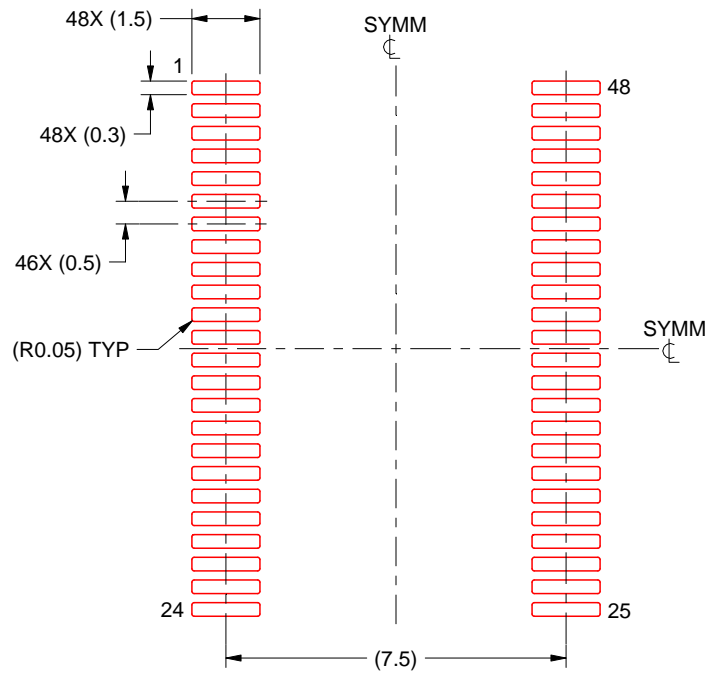

SOLDER PASTE EXAMPLE
BASED ON 0.125 mm THICK STENCIL
SCALE:6X

4214859/B 11/2020

NOTES: (continued)

7. Laser cutting apertures with trapezoidal walls and rounded corners may offer better paste release. IPC-7525 may have alternate design recommendations.
8. Board assembly site may have different recommendations for stencil design.

DGG (R-PDSO-G**)

PLASTIC SMALL-OUTLINE PACKAGE

48 PINS SHOWN

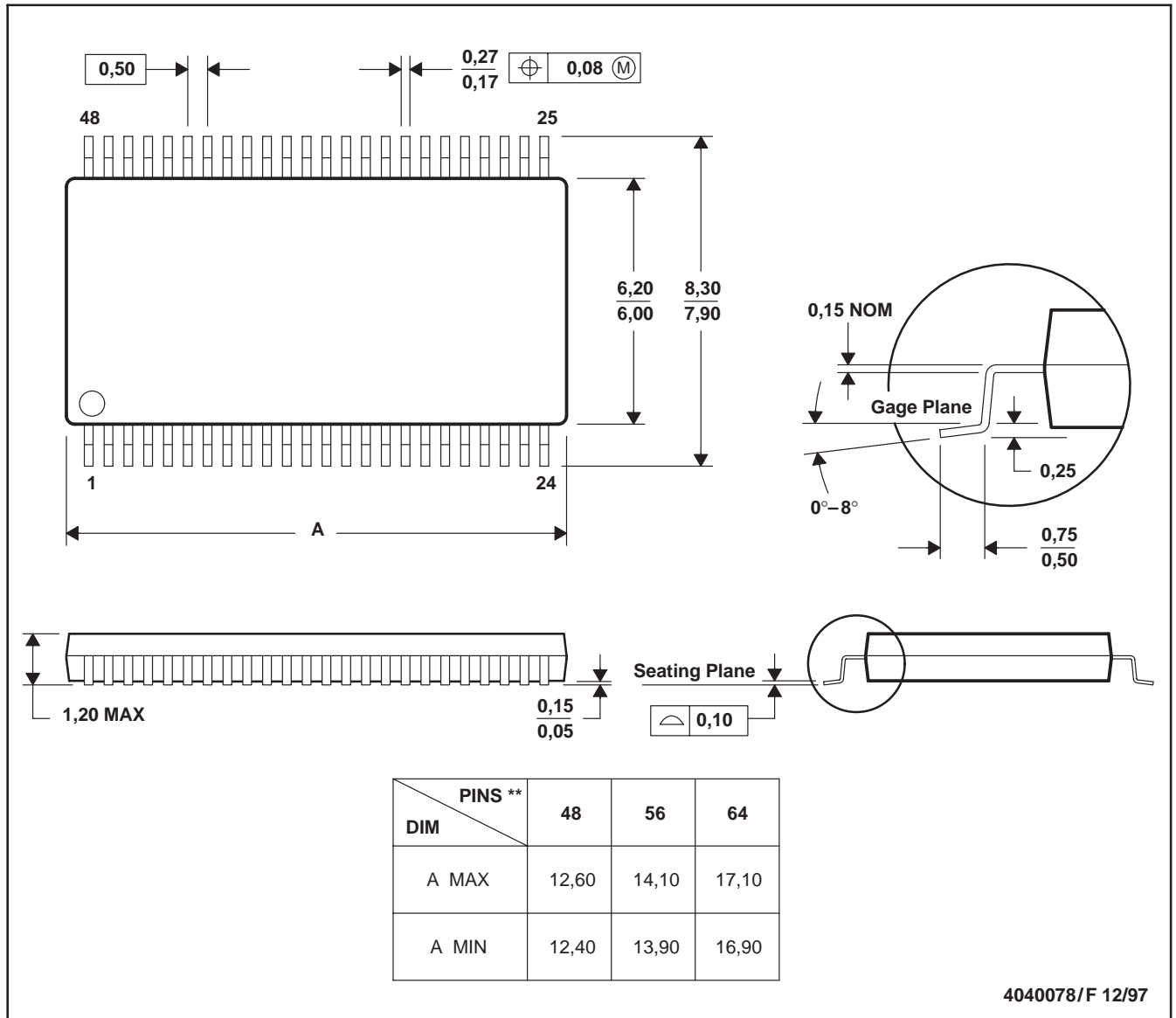

- NOTES: A. All linear dimensions are in millimeters.
 B. This drawing is subject to change without notice.
 C. Body dimensions do not include mold protrusion not to exceed 0,15.
 D. Falls within JEDEC MO-153

IMPORTANT NOTICE AND DISCLAIMER

TI PROVIDES TECHNICAL AND RELIABILITY DATA (INCLUDING DATA SHEETS), DESIGN RESOURCES (INCLUDING REFERENCE DESIGNS), APPLICATION OR OTHER DESIGN ADVICE, WEB TOOLS, SAFETY INFORMATION, AND OTHER RESOURCES "AS IS" AND WITH ALL FAULTS, AND DISCLAIMS ALL WARRANTIES, EXPRESS AND IMPLIED, INCLUDING WITHOUT LIMITATION ANY IMPLIED WARRANTIES OF MERCHANTABILITY, FITNESS FOR A PARTICULAR PURPOSE OR NON-INFRINGEMENT OF THIRD PARTY INTELLECTUAL PROPERTY RIGHTS.

These resources are intended for skilled developers designing with TI products. You are solely responsible for (1) selecting the appropriate TI products for your application, (2) designing, validating and testing your application, and (3) ensuring your application meets applicable standards, and any other safety, security, regulatory or other requirements.

These resources are subject to change without notice. TI grants you permission to use these resources only for development of an application that uses the TI products described in the resource. Other reproduction and display of these resources is prohibited. No license is granted to any other TI intellectual property right or to any third party intellectual property right. TI disclaims responsibility for, and you will fully indemnify TI and its representatives against, any claims, damages, costs, losses, and liabilities arising out of your use of these resources.

TI's products are provided subject to [TI's Terms of Sale](#) or other applicable terms available either on ti.com or provided in conjunction with such TI products. TI's provision of these resources does not expand or otherwise alter TI's applicable warranties or warranty disclaimers for TI products.

TI objects to and rejects any additional or different terms you may have proposed.

Mailing Address: Texas Instruments, Post Office Box 655303, Dallas, Texas 75265
Copyright © 2022, Texas Instruments Incorporated

Looking for pricing, stock, or lifecycle information?

Click below to explore more details on WIN SOURCE:

 [View 74ALVCH16245ZQLR on WIN SOURCE](#)

 [Texas Instruments](#) Information

Optimize Your Supply Chain with WIN SOURCE Solutions

-  Global Sourcing Solution
-  Obsolete Management
-  Cost Control Management
-  Shortage Management
-  Alternative Solution
-  Excess Inventory Management