



# THE DATASHEET OF MAX514AENG



# MAXIM

## CMOS Quad, 12-Bit, Serial-Input Multiplying DAC

MAX514

### General Description

The MAX514 contains four 12-bit R-2R multiplying digital-to-analog converters (DACs), each with a serial-in parallel-out shift register, a DAC register, and control logic. The MAX514's 3-wire serial interface design minimizes the number of package pins and internal level translators, so it uses less board space and dissipates less power (10mW max) than parallel-interface devices.

When used with microprocessors ( $\mu$ Ps) with a serial port, the MAX514 minimizes digital-noise feedthrough from its logic input pins to its analog output. To further reduce noise, the  $\mu$ P serial port can be used as a dedicated analog bus and kept inactive while the MAX514 is in use. Serial interfacing also simplifies opto-coupler or transformer-isolated applications.

This device uses low-tempco thin-film resistors, laser trimmed to  $\pm 1$ LSB linearity, with gain accuracy better than  $\pm 1\frac{1}{2}$ LSB.

The MAX514 is specified with a +5V power supply. All logic inputs are TTL and CMOS compatible. It comes in space-saving 24-pin DIP and 28-pin SO packages.

### Applications

- Digital Offset/Gain Adjustment
- Arbitrary Waveform Generators
- Industrial Process Controls
- Automatic Test Equipment
- Motion Control Systems
- Programmable Amplifiers/Attenuators
- $\mu$ P-Controlled Systems

### Functional Diagram

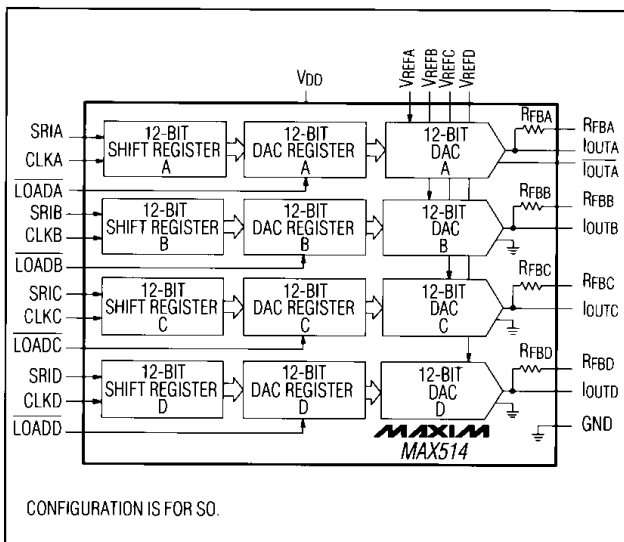

### Features

- ◆ Four 12-Bit Accurate DACs
- ◆ Fast 3-Wire Serial Interface
- ◆ Low Differential Nonlinearity:  $\pm \frac{1}{2}$ LSB Max
- ◆ Low Integral Nonlinearity:  $\pm 1$ LSB Max
- ◆ Gain Accuracy to  $\pm 1\frac{1}{2}$ LSB Max
- ◆ Low Gain Tempco: 5ppm/ $^{\circ}$ C Max
- ◆ Operates from a Single +5V Power Supply
- ◆ TTL/CMOS Compatible
- ◆ Available in 24-Pin DIP and 28-Pin SO Packages

### Ordering Information

PART	TEMP. RANGE	PIN-PACKAGE	DNL (LSBs)
MAX514ACNG	0 $^{\circ}$ C to +70 $^{\circ}$ C	24 Narrow Plastic DIP	$\pm 1/2$
MAX514BCNG	0 $^{\circ}$ C to +70 $^{\circ}$ C	24 Narrow Plastic DIP	$\pm 1$
MAX514ACWI	0 $^{\circ}$ C to +70 $^{\circ}$ C	28 Wide SO	$\pm 1/2$
MAX514BCWI	0 $^{\circ}$ C to +70 $^{\circ}$ C	28 Wide SO	$\pm 1$
MAX514AENG	-40 $^{\circ}$ C to +85 $^{\circ}$ C	24 Narrow Plastic DIP	$\pm 1/2$
MAX514BENG	-40 $^{\circ}$ C to +85 $^{\circ}$ C	24 Narrow Plastic DIP	$\pm 1$
MAX514AEWI	-40 $^{\circ}$ C to +85 $^{\circ}$ C	28 Wide SO	$\pm 1/2$
MAX514BEWI	-40 $^{\circ}$ C to +85 $^{\circ}$ C	28 Wide SO	$\pm 1$

### Pin Configurations

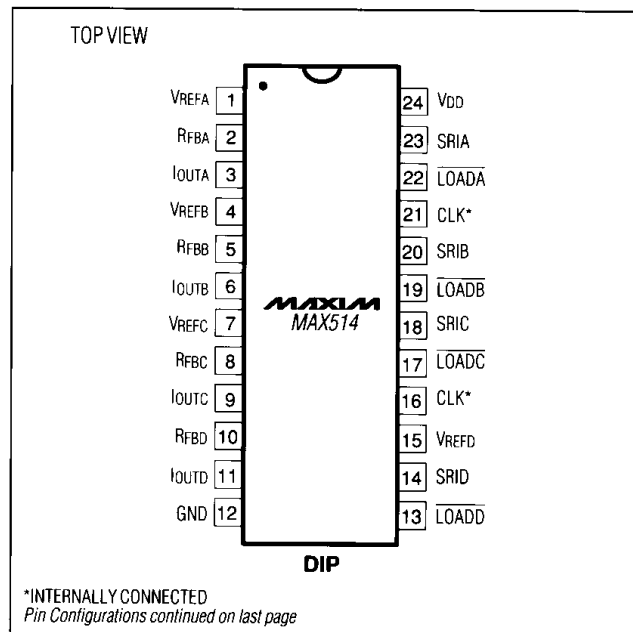

# CMOS Quad, 12-Bit, Serial-Input Multiplying DAC

## ABSOLUTE MAXIMUM RATINGS (Note 1)

V <sub>DD</sub> to GND	-0.3V, +17V
V <sub>REF</sub> to GND	±25V
V <sub>RFB</sub> to GND	±25V
Digital Input Voltage to GND	-0.3V, V <sub>DD</sub> + 0.3V
I <sub>OUTA</sub> to GND	-0.3V, V <sub>DD</sub> + 0.3V
Continuous Power Dissipation (T <sub>A</sub> = +70°C)	
24-Pin Narrow Plastic DIP	
(derate 8.7mW/°C above +70°C)	696mW

28-Pin Wide SO	
(derate 12.5mW/°C above +70°C)	1000mW/°C
Maximum Current into Any Pin	50mA
Operating Temperature Ranges:	
MAX514_C__	0°C to +70°C
MAX514_E__	-40°C to +85°C
Storage Temperature Range	-65°C to +150°C
Lead Temperature (soldering, 10 sec)	+300°C

Stresses beyond those listed under "Absolute Maximum Ratings" may cause permanent damage to the device. These are stress ratings only, and functional operation of the device at these or any other conditions beyond those indicated in the operational sections of the specifications is not implied. Exposure to absolute maximum rating conditions for extended periods may affect device reliability.

## ELECTRICAL CHARACTERISTICS

(V<sub>DD</sub> = +5V, V<sub>REF</sub> = +10V, I<sub>OUT</sub> = I<sub>OUTA</sub> = GND = 0V, T<sub>A</sub> = T<sub>MIN</sub> to T<sub>MAX</sub>, unless otherwise noted.)

PARAMETER	SYMBOL	CONDITIONS		MIN	TYP	MAX	UNITS
<b>STATIC PERFORMANCE</b>							
Resolution	N			12			Bits
Integral Nonlinearity	INL					±1	LSB
Differential Nonlinearity	DNL	Guaranteed monotonic	MAX514A			±1/2	LSB
			MAX514B			±1	
Full-Scale Error (Gain Error)	FSE	Using internal R <sub>FB</sub>	T <sub>A</sub> = +25°C	MAX514A		±1.5	LSB
			T <sub>A</sub> = T <sub>MIN</sub> to T <sub>MAX</sub>	MAX514B		±2.5	
Full-Scale Temperature Coefficient (Note 1)	TCFS	Using internal R <sub>FB</sub>			±1	±5	ppm/°C
DC Power-Supply Rejection	PSR	V <sub>DD</sub> = 4.75V to 5.25V				±0.001	%/%
<b>DYNAMIC PERFORMANCE (Note 1)</b>							
Current Settling Time	t <sub>s</sub>	T <sub>A</sub> = +25°C, to 1/2LSB, I <sub>OUT</sub> load is 100Ω    113pF, DAC register alternately loaded with all 1s and all 0s		0.25		1	μs
Digital Feedthrough	Q	V <sub>REF</sub> = 0V, I <sub>OUT</sub> load is 100Ω    113pF, DAC register alternately loaded with all 1s and all 0s		2		20	nV-s
AC Feedthrough at I <sub>OUT</sub>	FTE	V <sub>REF</sub> = ±10V <sub>p-p</sub> at 10kHz, DAC register loaded with all 0s		0.4		1	mV <sub>p-p</sub>
Total Harmonic Distortion	THD	V <sub>REF</sub> = 6V <sub>RMS</sub> at 1kHz, DAC register loaded with all 1s		-85			dB
Output Noise Voltage Density	e <sub>n</sub>	T <sub>A</sub> = +25°C, 10Hz to 100kHz, measured between R <sub>FB</sub> and I <sub>OUT</sub>		13		15	nV/√Hz
<b>REFERENCE INPUT</b>							
Reference Input Resistance	R <sub>REF</sub>	V <sub>REF</sub> pin to I <sub>OUT</sub>		7	11	25	kΩ
Input Resistance Tempco	TCR					-200	ppm/°C
<b>ANALOG OUTPUTS</b>							
I <sub>OUT</sub> Leakage Current	I <sub>LKG</sub>	DAC register loaded with all 0s	T <sub>A</sub> = +25°C	±0.5		±5	nA
			T <sub>A</sub> = T <sub>MIN</sub> to T <sub>MAX</sub>			±25	
I <sub>OUTA</sub> Leakage Current (DAC A, SO package only)	I <sub>LKG</sub>	DAC register loaded with all 1s	T <sub>A</sub> = +25°C	±0.5		±5	nA
			T <sub>A</sub> = T <sub>MIN</sub> to T <sub>MAX</sub>			±25	
I <sub>OUT</sub> Capacitance (Note 1)	C <sub>OUT1</sub>	DAC register loaded with all 0s		55		80	pF
		DAC register loaded with all 1s		85		110	
I <sub>OUTA</sub> Capacitance (DAC A, SO package only) (Note 1)	C <sub>OUT2</sub>	DAC register loaded with all 0s		85		110	pF
		DAC register loaded with all 1s		55		80	

# CMOS Quad, 12-Bit, Serial-Input Multiplying DAC

MAX514

## ELECTRICAL CHARACTERISTICS (continued)

( $V_{DD} = +5V$ ,  $V_{REF} = +10V$ ,  $I_{OUT} = \overline{I_{OUTA}} = GND = 0V$ ,  $T_A = T_{MIN}$  to  $T_{MAX}$ , unless otherwise noted.)

PARAMETER	SYMBOL	CONDITIONS	MIN	TYP	MAX	UNITS
<b>DIGITAL INPUTS</b>						
Digital Input High Voltage	$V_{IH}$		2.4			V
Digital Input Low Voltage	$V_{IL}$				0.8	V
Digital Input Leakage Current	$I_{IN}$	$V_{IN} = 0V$ or $V_{DD}$			$\pm 1$	$\mu A$
CLK Input Leakage Current (DIP only, pins 16, 21)	$I_{IN}$	$V_{IN} = 0V$ or $V_{DD}$			$\pm 4$	$\mu A$
Digital Input Capacitance (Note 1)	$C_{IN}$	$V_{IN} = 0V$ or $V_{DD}$			8	pF
CLK Input Capacitance (DIP only, pins 16, 21) (Note 1)	$C_{IN}$	$V_{IN} = 0V$ or $V_{DD}$			32	pF
<b>SWITCHING CHARACTERISTICS</b>						
CLK Pulse Width High	$t_{CH}$		90			ns
CLK Pulse Width Low	$t_{CL}$		120			ns
SRI Data to CLK Setup	$t_{DS}$		40			ns
SRI Data to CLK Hold	$t_{DH}$		80			ns
$\overline{LOAD}$ Pulse Width	$t_{LD}$		120			ns
LSB CLK to $\overline{LOAD}$	$t_{SL}$		0			ns
$\overline{LOAD}$ High to CLK	$t_{LC}$		0			ns
<b>POWER SUPPLIES</b>						
Positive Supply Voltage	$V_{DD}$	For specified performance	4.75		5.25	V
Positive Supply Current	$I_{DD}$	All digital inputs at $V_{IL}$ or $V_{IH}$			2000	$\mu A$
		All digital inputs at $0V$ or $V_{DD}$		20	400	

**Note 1:** Guaranteed by design, not subject to test.

## Typical Operating Characteristics

**GAIN vs. FREQUENCY**  
(OUTPUT AMPLIFIER: MAX400)

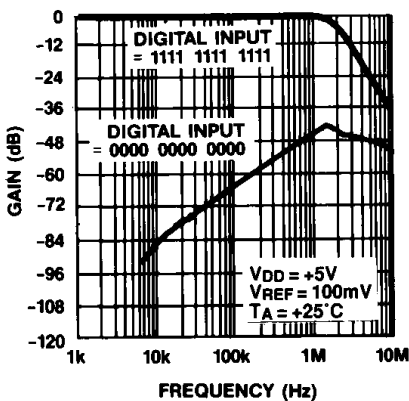

**TOTAL HARMONIC DISTORTION vs. FREQUENCY (MULTIPLYING MODE)**

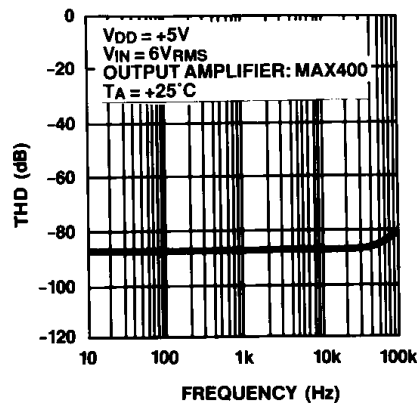

**SUPPLY CURRENT vs. LOGIC INPUT VOLTAGE**

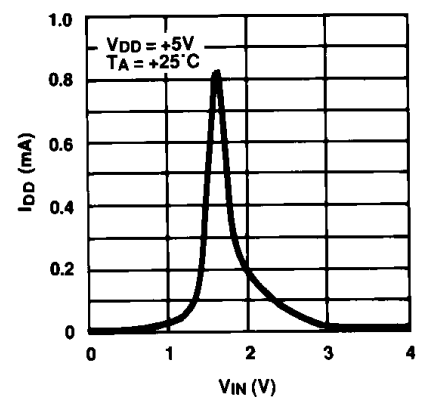

# CMOS Quad, 12-Bit, Serial-Input Multiplying DAC

## Typical Operating Characteristics (continued)

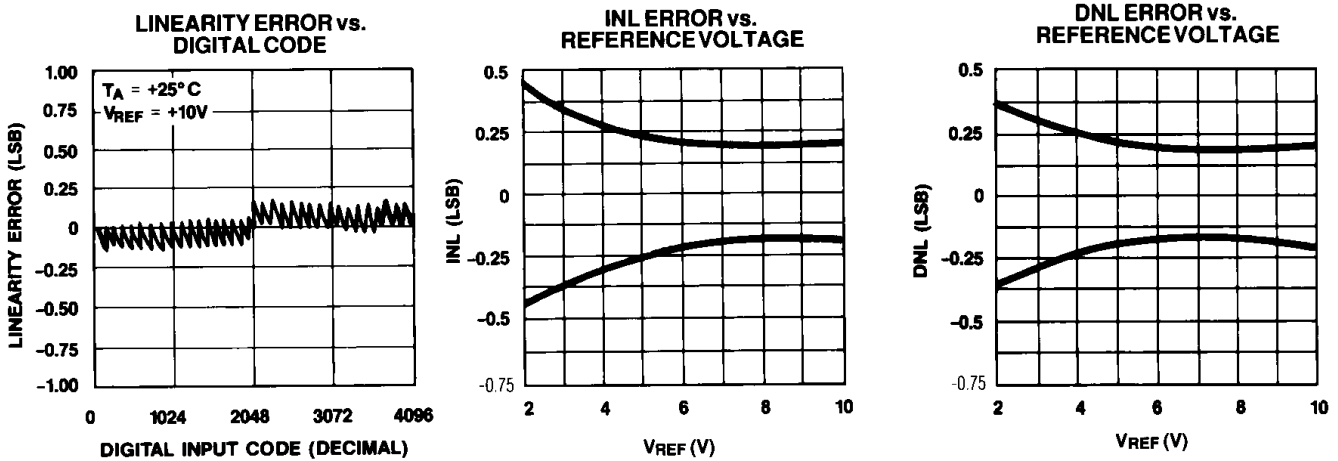

## Pin Description

24-PIN DIP	28-PIN SO	NAME	FUNCTION
1	1	VREFA	Reference Voltage Input for DACA
2	2	RFBA	Internal Feedback Resistor for DACA
3	3	IQUTA	DACA Output Current
-	4	IQUTA	DACA Inverted Current Output
4	5	VREFB	Reference Voltage Input for DACB
5	6	RFBB	Internal Feedback Resistor for DACB
6	7	IQUTB	DACB Output Current
7	8	VREFC	Reference Voltage Input for DACC
8	9	RFBC	Internal Feedback Resistor for DACC
9	10	IQUTC	DACC Output Current
15	11	VREFD	Reference Voltage Input for DACD
10	12	RFBD	Internal Feedback Resistor for DACD
11	13	IQUTD	DACD Output Current
12	14	GND	Power-Supply Ground
13	15	LOADD	Load DACD Input (active low). Driving this input low transfers the contents of shift register D to DAC register D and updates analog output D.
14	16	SRID	Serial Data Input for DACD
-	17	CLKD	Serial Clock Input for DACD
16, 21	-	CLK	Serial Clock Input for all four DACs. CLK pins are internally connected on DIP packaged parts.
17	18	LOADC	Load DACC Input (active low). Driving this input low transfers the contents of shift register C to DAC register C and updates analog output C.
18	19	SRIC	Serial Data Input for DACC
-	20	CLKC	Serial Clock Input for DACC
19	21	LOADB	Load DACB Input (active low). Driving this input low transfers the contents of shift register B to DAC register B and updates analog output B.
20	22	SRIB	Serial Data Input for DACB
-	23	CLKB	Serial Clock Input for DACB
-	24	N.C.	No Connect
22	25	LOADA	Load DACA Input (active low). Driving this input low transfers the contents of shift register A to DAC register A and updates analog output A.
23	26	SRIA	Serial Data Input for DACA
-	27	CLKA	Serial Clock Input for DACA
24	28	VDD	Positive Supply Voltage

# CMOS Quad, 12-Bit, Serial-Input Multiplying DAC

MAX514

## Detailed Description

### DAC Section

The MAX514 contains four current-output digital-to-analog converters (DACs). Each DAC consists of a laser-trimmed R-2R resistor array with NMOS current switches as shown in Figure 1. Binary weighted currents are switched to either I<sub>OUT</sub> or GND (I<sub>OUTA</sub> for DAC A, SO package only), depending upon the status of each input data bit.

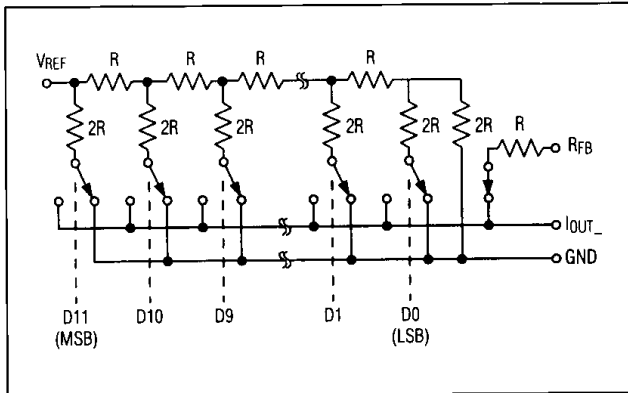

Figure 1. Simplified D/A Circuit for 1/4 of MAX514

Each of the current outputs (I<sub>OUT</sub>) can be converted to a voltage by adding an external output amplifier as shown in Figure 3. V<sub>REF</sub> inputs accept a wide range of signals, including fixed and time-varying voltage or current inputs. If a current source is used for the reference input, a low tempco external resistor should be used for R<sub>FB</sub> to minimize gain variation with temperature.

Each internal feedback resistor (R<sub>FB</sub>) is compensated with an NMOS switch that matches the NMOS switches used in the R-2R array. This results in excellent power-supply rejection and gain-temperature coefficient.

### Digital Inputs and Interface Logic

Figure 2 shows the write-cycle timing diagram for the MAX514. The most significant bit (MSB) is always loaded first on the rising edge of the clock (CLK). Once all data is shifted into the MAX514, each DAC register is loaded by taking the corresponding  $\overline{\text{LOAD}}$  signal low. The DAC registers are transparent when their  $\overline{\text{LOAD}}$  input is low, and latched when their  $\overline{\text{LOAD}}$  input is high. If  $\overline{\text{LOAD}}$  is taken low before the least significant bit (LSB) is shifted into the shift register, the DAC output can produce a "glitch." If this is undesirable, avoid it by delaying the  $\overline{\text{LOAD}}$  signal 30ns after the rising edge of the LSB CLK edge.

The digital interface of the dual-in-line package (DIP) and small outline (SO) devices differs slightly. Each DAC in the SO has its own CLK input, while DACs in the DIP share a common CLK input. The common CLK input of the DIPs is located on pins 16 and 21, which are internally connected. DACs can be individually loaded by separately controlling the four  $\overline{\text{LOAD}}$  inputs. Data is shifted into each DAC through its SRI pin using the common CLK input. The output voltage of each DAC is updated after its  $\overline{\text{LOAD}}$  input has been exercised, while the remaining DAC outputs are unchanged.

If simultaneous updating of all four DAC outputs is desired, the  $\overline{\text{LOAD}}$  inputs on DIP devices should be bussed together and driven from a common source. Simultaneous updating of the four DAC outputs on SO devices can be accomplished by bussing the four CLK inputs together and the four  $\overline{\text{LOAD}}$  inputs together.

The MAX514's input buffers act as level shifters, converting TTL levels into DAC switch-drive levels. Input buffers are compatible with both TTL and 5V CMOS logic, however the power supply current (I<sub>DD</sub>) is dependent upon the input logic levels. Supply current is significantly

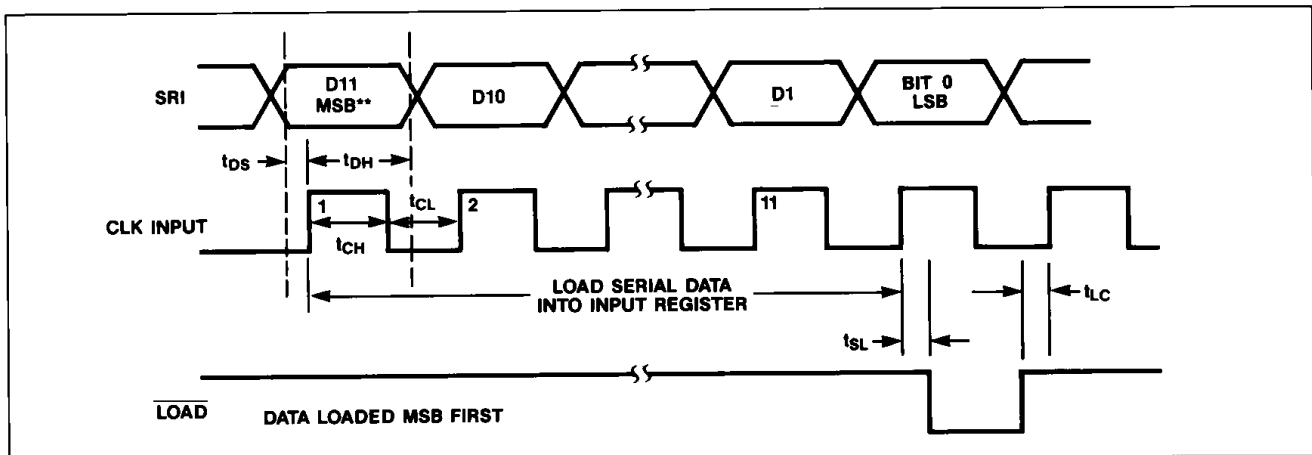

Figure 2. Write-Cycle Timing Diagram

# CMOS Quad, 12-Bit, Serial-Input Multiplying DAC

reduced when logic inputs are driven as close to DGND as possible, and above 4V. This phenomenon is shown in the *Supply Current vs. Logic Input Voltage* graph in the *Typical Operating Characteristics*.

## Circuit Configurations Unipolar Operation

Figure 3 shows the basic application circuit for one-fourth of the MAX514. This circuit is used for unipolar operation or 2-quadrant multiplication. The unipolar output-code table is given in Table 1. Note that the polarity of the output voltage is the inverse of the reference voltage input (VREF).

In many applications, gain adjustment will not be necessary: The gain accuracy of the part may be sufficient, or gain may be trimmed at the reference source. In these cases, resistors R1 and R2 in Figure 3 can be omitted. When the DAC is trimmed and operated over a wide

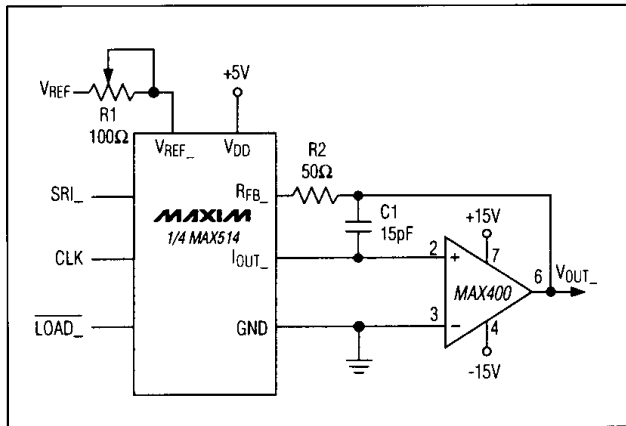

Figure 3. Unipolar Operation for 1/4 of MAX514

Table 1. Unipolar Binary Code Table for Circuit of Figure 3

DIGITAL INPUT		ANALOG OUTPUT
MSB	LSB	
1 1 1 1	1 1 1 1	$-V_{REF} \left( \frac{4095}{4096} \right)$
1 0 0 0	0 0 0 0	$-V_{REF} \left( \frac{2048}{4096} \right) = -\frac{V_{REF}}{2}$
0 0 0 0	0 0 0 1	$-V_{REF} \left( \frac{1}{4096} \right)$
0 0 0 0	0 0 0 0	0

temperature range, use low tempco (<300ppm/°C) resistors for R1 and R2.

The capacitor, C1, provides phase compensation and reduces overshoot and ringing when fast amplifiers are used at the DAC outputs.

## Bipolar Operation

Figure 4 shows the MAX514 operating in the bipolar, or 4-quadrant multiplying mode. A second amplifier and three matched resistors (R3, R4, and R5) are required for each DAC output. These resistors must be of the same material (preferably metal film or wire-wound) for good temperature tracking characteristics (<15ppm/°C), and should match to 0.01% for 12-bit performance. The output code is offset binary and is listed in Table 2. In multiplying applications, the MSB determines output polarity while the other 11 bits control the amplitude. The MSB can be inverted in software using an exclusive-OR

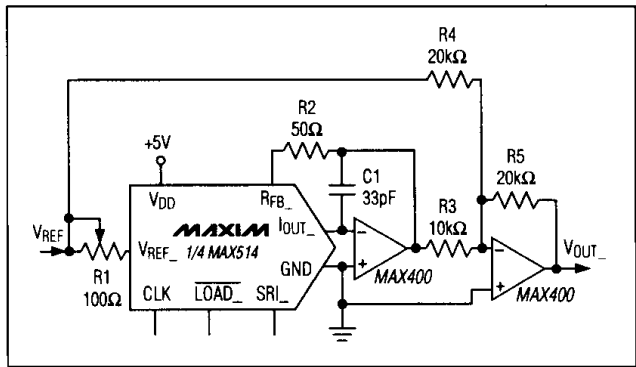

Figure 4. Bipolar Operation for 1/4 of MAX514

Table 2. Offset Binary Code Table for Circuit of Figure 4

DIGITAL INPUT		ANALOG OUTPUT
MSB	LSB	
1 1 1 1	1 1 1 1	$+V_{REF} \left( \frac{2047}{2048} \right)$
1 0 0 0	0 0 0 1	$+V_{REF} \left( \frac{1}{2048} \right)$
1 0 0 0	0 0 0 0	0
0 1 1 1	1 1 1 1	$-V_{REF} \left( \frac{1}{2048} \right)$
0 0 0 0	0 0 0 0	$-V_{REF} \left( \frac{2048}{2048} \right)$

# CMOS Quad, 12-Bit, Serial-Input Multiplying DAC

MAX514

Table 3. Twos Complement Code Table

DIGITAL INPUT			ANALOG OUTPUT
MSB	LSB		
0 1 1 1	1 1 1 1	1 1 1 1	$+V_{REF} \left( \frac{2047}{2048} \right)$
0 0 0 0	0 0 0 0	0 0 0 1	$+V_{REF} \left( \frac{1}{2048} \right)$
0 0 0 0	0 0 0 0	0 0 0 0	0
1 1 1 1	1 1 1 1	1 1 1 1	$-V_{REF} \left( \frac{1}{2048} \right)$
1 0 0 0	0 0 0 0	0 0 0 0	$-V_{REF} \left( \frac{2048}{2048} \right)$

instruction to make the MAX514 work with twos-complement coding. Table 3 shows the code relationships to output voltage for the twos-complement operation.

To adjust the circuit, load the DAC with a code of 1000 0000 0000 and trim R1 for a 0V output. With R1 and R2 omitted, an alternative zero trim is used to adjust the ratio of R3 and R4 for 0V out. Full-scale error can be trimmed by loading the DAC with all 0s or all 1s, and adjusting the amplitude of VREF or varying R5 until the desired positive or negative output is obtained. Gain adjustment will not be necessary in many applications, in which case resistors R1 and R2 in Figure 4 can be omitted. If gain trimming is desired, low tempco (<300ppm/°C) resistors should be used for R1 and R2.

### Single-Supply Operation (Voltage Mode)

The MAX514 can be conveniently used in voltage mode with a single supply. IOUT must not be allowed to go 0.3V lower than GND or 0.3V higher than VDD. Otherwise, internal protection diodes may turn on, causing high current flow and possible damage to the device.

Figure 5 shows the MAX514 connected as a voltage-output DAC. IOUT is connected to the reference voltage source and GND is grounded (IOUTA, on the SO package, should also be grounded). The DAC output now appears at the VREF pin, which has a constant impedance equal to the reference input resistance (typically 11kΩ). This output should be buffered with an op amp when lower output impedance is required. The RFB pin is not used in this mode.

The input impedance of the reference input (IOUT) for this mode is code dependent, and the circuit response time

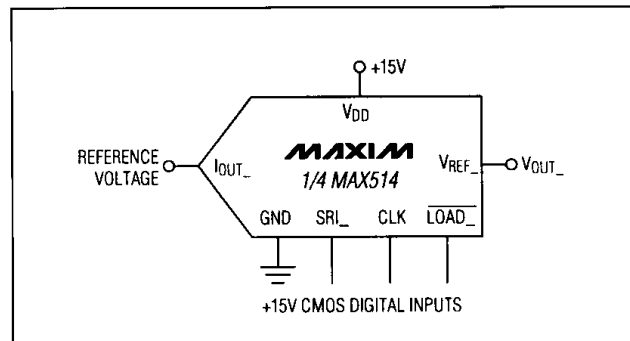

Figure 5. Single-Supply Operation for 1/4 of MAX514 Using Voltage Switching Mode

depends on the reference source's behavior with changing load conditions.

Since a negative reference is not required for a positive output when operating in voltage mode, the complete circuit can be powered from a single supply. Note that, when operating in voltage mode, the reference input (IOUT) must always be positive and is limited to no more than 2.5V when VDD is 15V. If the reference voltage is greater than 2.5V or VDD is reduced, resistance mismatches in the DAC's internal NMOS switches result in degraded integral nonlinearity (INL) and differential nonlinearity (DNL).

The unipolar and bipolar circuits in Figures 3 and 4 can all be converted to voltage output mode.

## Applications Information

### Output Amplifier Offset

For best linearity, IOUT, IOUTA, and GND should be terminated at exactly 0V. In most applications, IOUT is connected to the summing junction of an inverting op amp. The amplifier's input offset voltage can degrade the DAC's linearity by causing IOUT to be terminated to a non-zero voltage. The resulting error is:

$$\text{Error Voltage} = V_{OS} (1 + R_{FB} / R_O)$$

where VOS is the op amp's offset voltage and RO is the output resistance of the DAC. RO is a function of the digital input code, and varies from approximately 11kΩ to 33kΩ. The error voltage range is then typically 4/3VOS to 2VOS, a change of 2/3VOS. An amplifier with 3mV of offset, therefore, degrades linearity by 2mV — almost a full LSB when a 10V reference voltage is used. For best linearity, amplifiers with low offset voltage (such as the MAX400) should be used as output amplifiers for the MAX514. A good rule of thumb is that VOS should be no more than 1/10LSB.

The output-amplifier input bias current (IB) can also limit performance since IB x RFB generates an offset error. IB should, therefore, be much less than the DAC output

# CMOS Quad, 12-Bit, Serial-Input Multiplying DAC

current for 1LSB, which is typically 250nA with a 10V reference voltage. One-tenth of this value, 25nA, is recommended. Offset and linearity can also be impaired if the output amplifier noninverting input is grounded through a "bias-current compensation resistor." This resistor adds to the offset at this pin and should not be used. Best performance is obtained when the noninverting input is directly connected to GND.

## Dynamic Considerations

In static or DC applications, the AC characteristics of the output amplifier are not critical. In higher speed applications, where either the reference input is an AC signal or the DAC output must quickly settle to a new programmed value, the AC parameters of the output op amp must be considered.

Another error source in dynamic applications is parasitic signal coupling from the VREF inputs to IOUT. This coupling is primarily a function of board layout and lead-to-lead package capacitance. Noise signals can also be injected into the DAC outputs when the digital inputs are switched. This digital feedthrough is usually dependent upon the circuit-board layout and on-chip capacitive coupling. Guard traces between the digital input, VREF inputs, and IOUT pins minimize layout-induced feedthrough. Each DAC output follows the digital inputs when the corresponding LOAD pin is low. In this state, invalid outputs and voltage glitches can appear at the DAC outputs. Keeping the LOAD inputs high until all of the data is shifted into the DAC eliminates this problem.

## Compensation

A compensation capacitor, C1, may be required when the DAC is used with a high-speed output amplifier. The purpose of the capacitor is to cancel the pole formed by the DAC output capacitance, C<sub>OUT</sub>, and the internal feedback resistor, R<sub>F</sub>. The value of this capacitor depends on the type of op amp used, but it typically ranges from 10pF to 33pF. Too small a value causes output ringing, while excessive capacitance overdamps the output. The size of C1 can be minimized and the output voltage settling time improved by keeping the circuit-board trace and stray capacitance at IOUT at low as possible.

The capacitance at each IOUT pin (C<sub>OUT</sub>) is code dependent and is typically 55pF with all switches connected to GND, and 85pF with all switches connected to IOUT.

## Grounding and Bypassing

Since IOUT and the noninverting input of the output amplifier are sensitive to offset voltages, nodes that are to be grounded should be connected directly to a "single point" ground through a separate, low-resistance (less than 0.2Ω) connection. The current at IOUT and GND varies with input code, creating a code-dependent error

if these terminals are connected to GND (or a "virtual ground") through a resistive path.

A 1μF bypass capacitor, in parallel with a 0.01μF ceramic capacitor, should be connected across the DAC V<sub>DD</sub> and GND as close to the pins as possible.

The MAX514 has high-impedance digital inputs. To minimize noise pick-up and prevent static charge accumulation if the pins are left floating (such as when a circuit card is left unconnected), they should be tied to either V<sub>DD</sub> or GND through high-value resistors (1MΩ).

## Pin Configurations (continued)

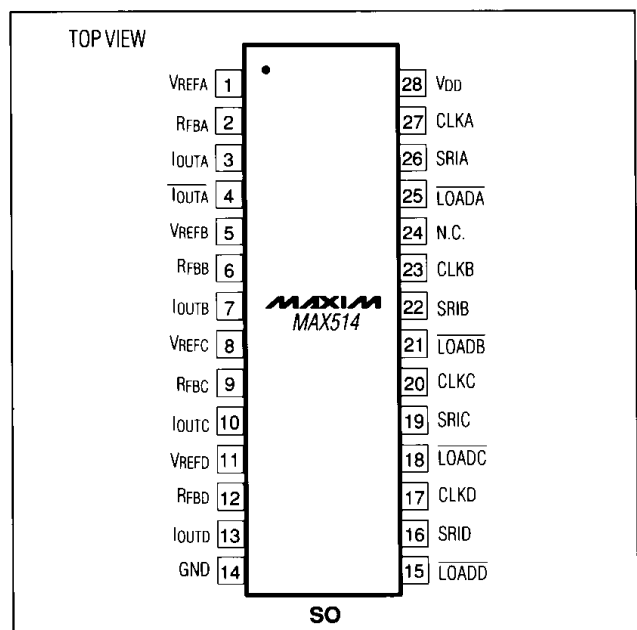

Maxim cannot assume responsibility for use of any circuitry other than circuitry entirely embodied in a Maxim product. No circuit patent licenses are implied. Maxim reserves the right to change the circuitry and specifications without notice at any time.

8 Maxim Integrated Products, 120 San Gabriel Drive, Sunnyvale, CA 94086 408-737-7600

## Looking for pricing, stock, or lifecycle information?

Click below to explore more details on WIN SOURCE:

 [View MAX514AENG on WIN SOURCE](#)

 [Maxim Integrated](#) Information

## Optimize Your Supply Chain with WIN SOURCE Solutions

-  Global Sourcing Solution
-  Obsolete Management
-  Cost Control Management
-  Shortage Management
-  Alternative Solution
-  Excess Inventory Management