



**THE DATASHEET OF  
CHL8225-02CRT**



## FEATURES

- 5-phase & 8-phase dual output PWM Controller with phases flexibly assigned between Loops 1 & 2
- Dynamic voltage control by 2-bit parallel interface with Gamer Mode override and Vmax setting
- Input Voltage Management for up to 3 Input Voltages
- I<sub>CRITICAL</sub> Monitor and Phase Current Capture Mode
- Phase Switching frequency from 200kHz to 1.2MHz
- CHiL Efficiency Shaping Features including Variable Gate Drive, Dynamic Phase Control
- Programmable 1-phase or 2-phase for Light Loads and Active Diode Emulation for Very Light Loads
- CHiL Adaptive Transient Algorithm (ATA) minimizes output bulk capacitors and system cost
- Designed for use with coupled inductors
- Per-Loop Fault Protection: OVP, UVP, OCP, OTP
- I2C/SMBus/PMBus system interface for telemetry of Temperature, Voltage, Current & Power for both loops
- Non-Volatile Memory (NVM) for custom configuration
- Compatible with CHiL ATL and 3.3V tri-state Drivers
- +3.3V supply voltage; 0°C to 85°C ambient operation
- Pb-Free, RoHS, 6x6 40pin & 8x8 56pin QFN packages

## DESCRIPTION

The CHL8225/8 are dual-loop digital multi-phase buck controllers. The CHL8225 drives up to 5 phases and the CHL8228 drives up to 8 phases. They feature Input Voltage Management allowing up to 3 input voltages to be monitored to ensure adequate power is delivered to the load. Dynamic voltage control is provided by 4 registers which are programmed through I2C/SMBus/PMBus and then selected using a 2-bit parallel bus for fast access.

The CHL8225/8 NVM saves pins and enables a small package size.

The CHL8225/8 includes the CHiL Efficiency Shaping Technology to deliver exceptional efficiency at minimum cost across the entire load range. CHiL Variable Gate Drive optimizes the MOSFET gate drive voltage as a function of real-time load current. CHiL Dynamic Phase Control adds and drops phases based upon load current. The CHL8225/8 can be configured to enter 1-phase operation and active diode emulation mode based upon load current or by command.

CHiL's unique Adaptive Transient Algorithm (ATA), based on proprietary non-linear digital PWM algorithms, minimizes output bulk capacitors. In addition, a coupled inductor mode, with phases added/dropped in pairs enables further improvement in transient response and form factor.

The I2C/PMBus interface can communicate with up to 16 CHL8225/8 based VR loops. Device configuration and fault

parameters are easily defined using the CHiL Intuitive Power Designer (IPD) GUI and stored in on-chip NVM.

The CHL8225/8 provides extensive OVP, UVP, OCP and OTP fault protection and includes thermistor based temperature sensing with VRHOT signal.

The CHL8225/8 includes numerous features like register diagnostics for fast design cycles and platform differentiation, simplifying VRD design and enabling fastest time-to-market with its "set-and-forget" methodology.

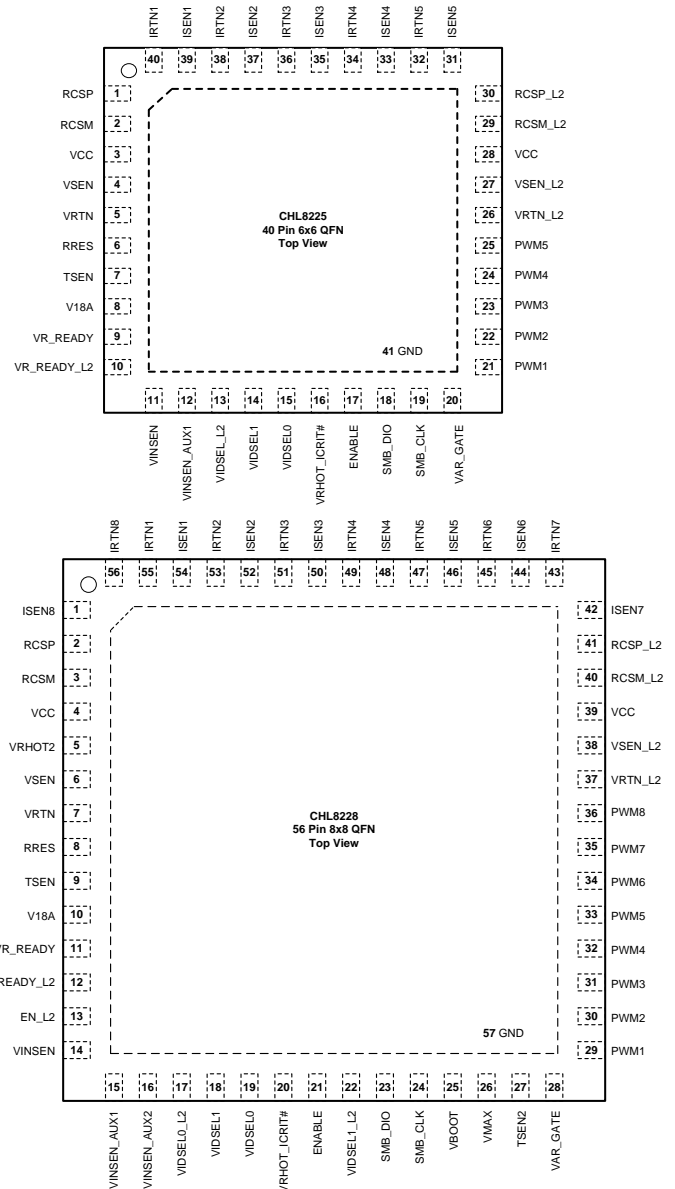
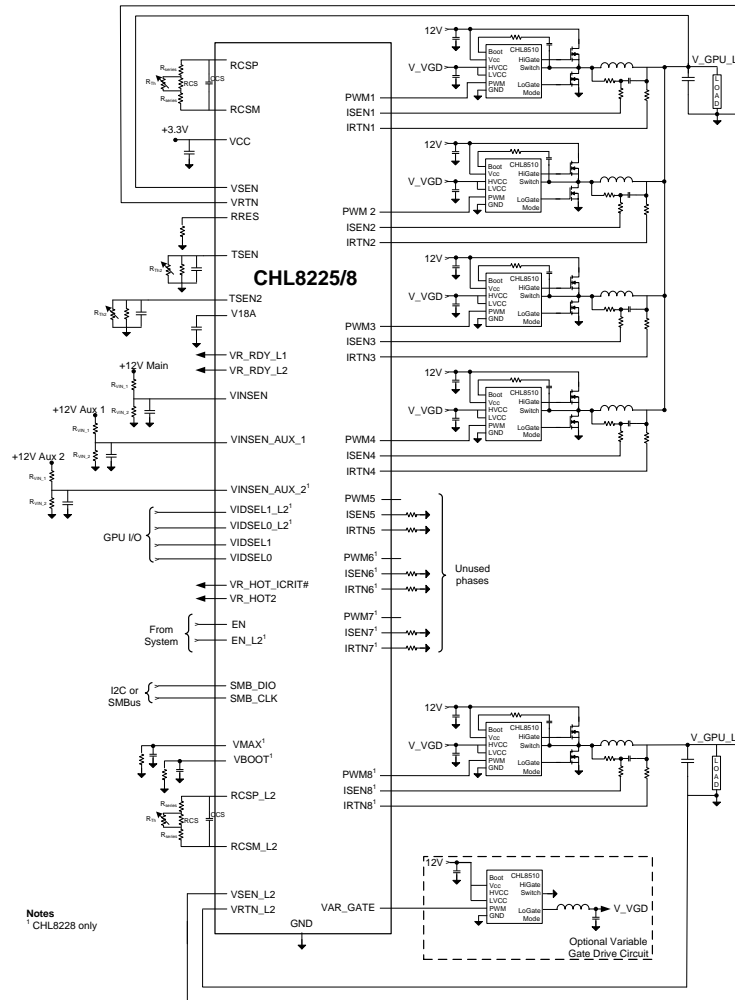

Figure 1: CHL8225 & CHL8228 Packages

## APPLICATIONS

- Multiphase GPU systems

**TYPICAL APPLICATIONS BLOCK DIAGRAM**



**ORDERING INFORMATION**

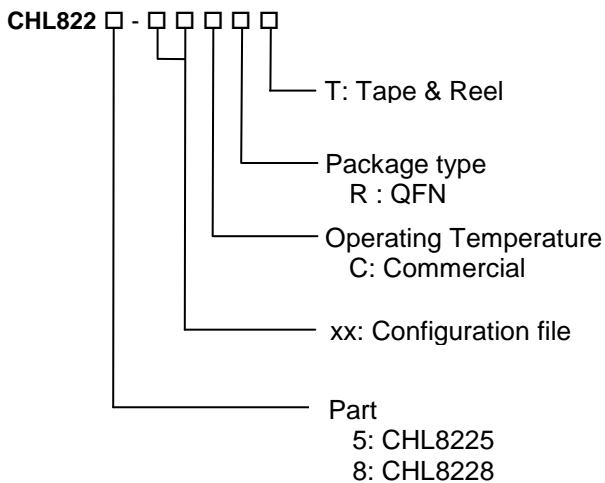

Package	Tape & Reel Qty	Part Number
QFN	3000	CHL8225-00CRT <sup>1</sup>
QFN	3000	CHL8225-xxCRT <sup>2</sup>
QFN	3000	CHL8228-00CRT <sup>1</sup>
QFN	3000	CHL8228-xxCRT <sup>2</sup>

**Notes**

- 1 For unprogrammed/default parts, use configuration file 00. Unprogrammed parts will not start up until programmed in order to insure a safe power up.
- 2 -xx indicates a customer specific configuration file.

## Looking for pricing, stock, or lifecycle information?

Click below to explore more details on WIN SOURCE:

 [View CHL8225-02CRT on WIN SOURCE](#)

 [Infineon Technologies](#) Information

## Optimize Your Supply Chain with WIN SOURCE Solutions

-  Global Sourcing Solution
-  Obsolete Management
-  Cost Control Management
-  Shortage Management
-  Alternative Solution
-  Excess Inventory Management