



**THE DATASHEET OF
AP3968DMTR-G1**



Primary Side Power Switcher for Off-line SMPS**AP3968D****General Description**

The AP3968D consists of a primary side regulation controller and a high voltage transistor, and is specially designed for off-line power supplies within 4W output power. Typical applications include adapter for ADSL and auxiliary supplies.

The AP3968D operates at pulse frequency modulation (PFM), and provides accurate constant voltage, constant current (CV/CC) regulation without requiring an opto-coupler and secondary control circuitry. It has internal cable compensation function for tight constant voltage regulation.

The AP3968D solution has fewer component numbers, smaller size, and lower total cost.

The AP3968D is packaged in SOIC-7.

Features

- Primary Side Control for Eliminating Opto-coupler and Secondary CV/CC Control Circuitry
- Built-in NPN Transistor with $700V_{CBO}$
- Low Start-up Current: $0.2\mu A$ (Typ.)
- Internal Output Cable Voltage Drop Compensation
- Random Frequency Modulation for Low EMI
- Short Circuit Protection
- Low Total Cost Solution
- Output Power Range: For 4W Adapter

Applications

- Chargers
- Adapters
- Set Top Boxes
- Auxiliary Supplies
- DVD
- LED Driver



Figure 1. Package Type of AP3968D

Pin Configuration

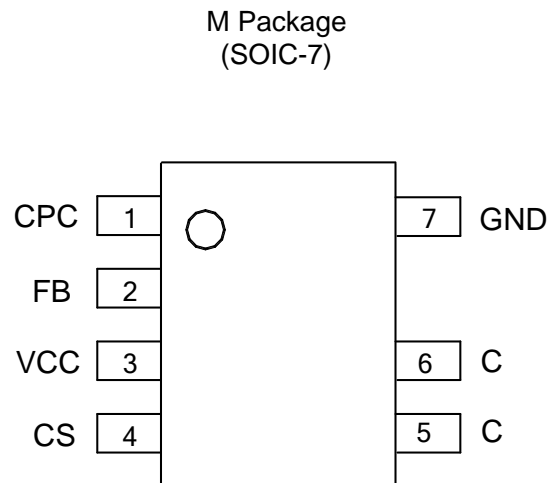

Figure 2. Pin Configuration of AP3968D (Top View)

Pin Description

Pin Number	Pin Name	Function
1	CPC	This pin connects a capacitor to GND for output cable compensation
2	FB	The voltage feedback from auxiliary winding
3	VCC	This pin receives rectified voltage from the auxiliary winding of the transformer
4	CS	Current sense for primary side of transformer
5, 6	C	This pin is connected with an internal power BJT's collector
7	GND	This pin is the signal reference ground

Functional Block Diagram

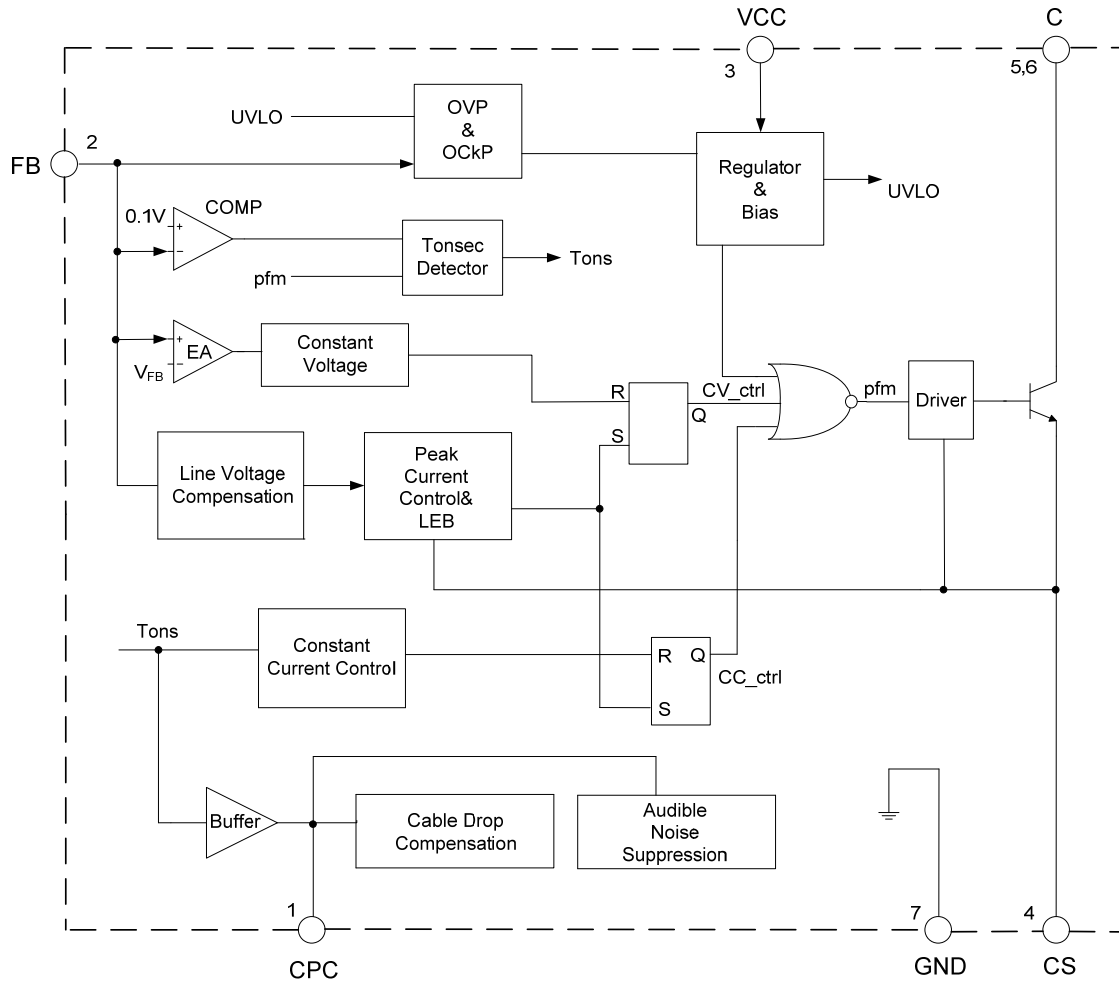

Figure 3. Functional Block Diagram of AP3968D



Primary Side Power Switcher for Off-line SMPS

AP3968D

Ordering Information

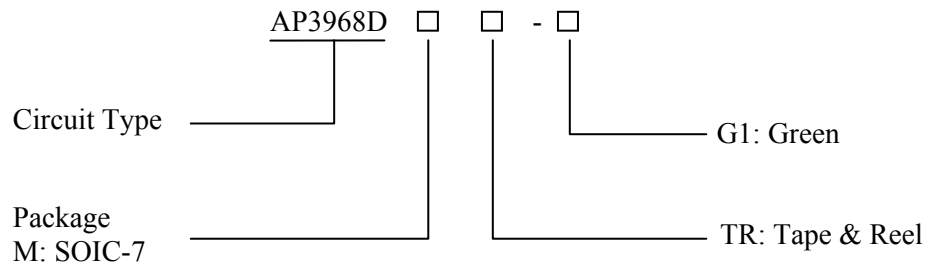

Package	Temperature Range	Part Number	Marking ID	Packing Type
SOIC-7	-40 to 85°C	AP3968DMTR-G1	3968DM-G1	Tape & Reel

BCD Semiconductor's Pb-free products, as designated with "G1" suffix in the part number, are RoHS compliant and green.

**Primary Side Power Switcher for Off-line SMPS****AP3968D****Absolute Maximum Ratings (Note 1)**

Parameter	Symbol	Value	Unit
Supply Voltage	V_{CC}	-0.3 to 22	V
FB Input Voltage	V_{FB}	-1 to 10	V
Collector-emitter Voltage	V_{CBO}	700	V
Collector DC Current		0.8	A
Operating Junction Temperature	T_J	150	°C
Storage Temperature	T_{STG}	-65 to 150	°C
Lead Temperature (Soldering, 10 sec)	T_{LEAD}	300	°C
ESD (Machine Model)		200	V
ESD (Human Body Model)		2000	V

Note 1: Stresses greater than those listed under “Absolute Maximum Ratings” may cause permanent damage to the device. These are stress ratings only, and functional operation of the device at these or any other conditions beyond those indicated under “Recommended Operating Conditions” is not implied. Exposure to “Absolute Maximum Ratings” for extended periods may affect device reliability.

Recommended Operating Conditions

Parameter	Symbol	Min	Max	Unit
Supply Voltage	V_{CC}		22	V
Operating Temperature Range	T_{OP}	-40	85	°C
Maximum Operating Frequency	f_{MAX}		60	kHz

**Primary Side Power Switcher for Off-line SMPS****AP3968D****Electrical Characteristics** $V_{CC}=15V$, $T_J=25^{\circ}C$, unless otherwise specified.

Parameter	Symbol	Conditions	Min	Typ	Max	Unit
UVLO Section						
Turn-on Voltage	V_{ON}		13	15	17	V
Turn-off Voltage	V_{OFF}	No drive Current	4.5	5.3	6.3	V
Standby Current Section						
Start-up Current	I_{ST}	$V_{CC}=V_{ON}-0.5V$		0.2	0.6	μA
Operating Current	I_{CC}		320	435	550	
Feedback Input Section						
FB Input Current	I_{FB}	$V_{FB}=4V$	1.5	3.5	5.5	μA
FB Threshold Voltage	V_{FB}		4.214	4.278	4.342	V
Power Transistor Section						
Collector-emitter Saturation Voltage	$V_{CE(SAT)}$	$I_C=200mA$			0.3	V
DC Current Gain	h_{FE}		15	23		
Leakage Current	I_{CEO}				60	nA
Over Temperature Protection						
Shutdown Temperature	T_{SHDN}	Surface temperature	125	160		$^{\circ}C$
Temperature Hysteresis				40		$^{\circ}C$

Thermal Impedance

Parameter	Symbol	Value	Unit
Junction to Ambient	θ_{JA}	80	$^{\circ}C/W$
Junction to Case	θ_{JC}	40	



Typical Performance Characteristics

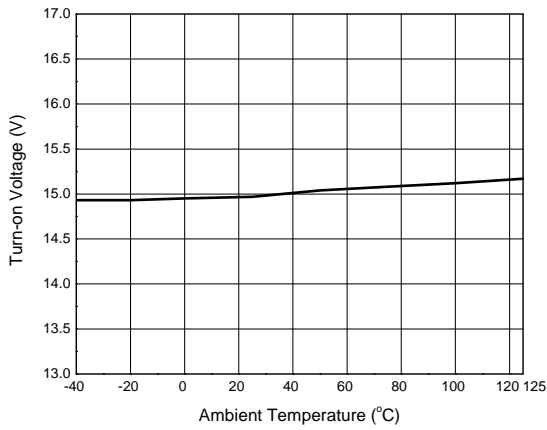

Figure 4. Turn-on Voltage vs. Ambient Temperature

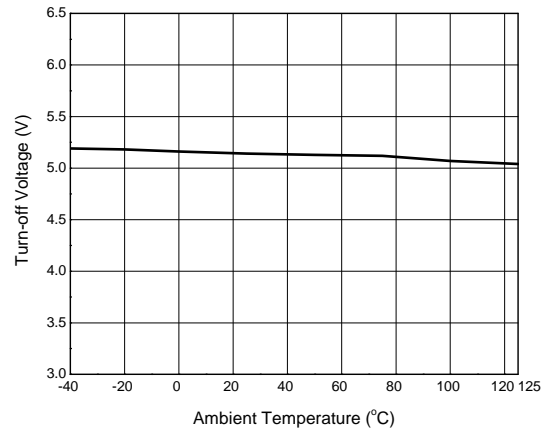

Figure 5. Turn-off Voltage vs. Ambient Temperature

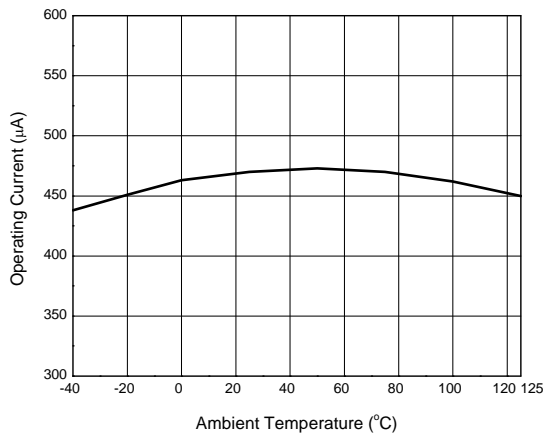

Figure 6. Operating Current vs. Ambient Temperature

Operation Description

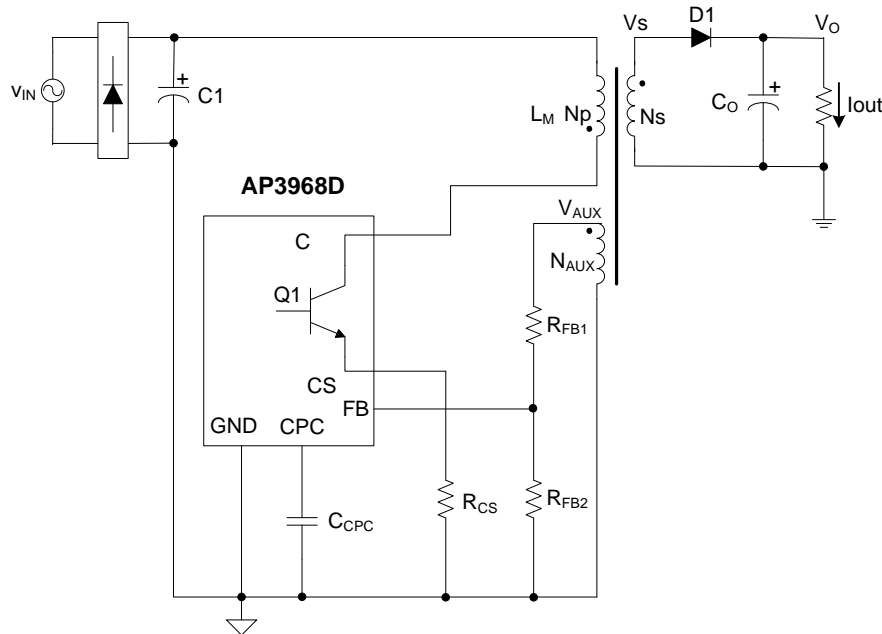

Figure 7. Simplified Flyback Converter Controlled by AP3968D

Figure 7 illustrates a simplified flyback converter controlled by AP3968D.

$$I_{pk} = \frac{V_{cs}}{R_{cs}} \dots\dots\dots(2)$$

Constant Primary Peak Current

The primary current $I_p(t)$ is sensed by a current sense resistor R_{CS} as shown in Figure 7.

The energy stored in the magnetizing inductance L_M each cycle is therefore:

The current rises up linearly at a rate of:

$$E_g = \frac{1}{2} \cdot L_M \cdot I_{pk}^2 \dots\dots\dots(3)$$

$$\frac{di_p(t)}{dt} = \frac{v_g(t)}{L_M} \dots\dots\dots(1)$$

So the power transferring from input to output is given by:

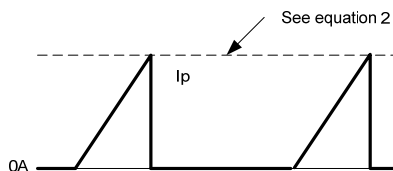

$$P = \frac{1}{2} \cdot L_M \cdot I_{pk}^2 \cdot f_{sw} \dots\dots\dots(4)$$

Figure 8. Primary Current Waveform

Where f_{sw} is the switching frequency. When the peak current I_{pk} is constant, the output power depends on the switching frequency f_{sw} .

As illustrated in Figure 8, when the current $I_p(t)$ rises up to I_{pk} , the switch Q1 turns off. The constant peak current is given by:

Constant Voltage Operation

The AP3968D captures the auxiliary winding feedback voltage at FB pin and operates in constant-voltage (CV) mode to regulate the output

Primary Side Power Switcher for Off-line SMPS

AP3968D

voltage. Assuming the secondary winding is master, the auxiliary winding is slave during the D1 on-time. The auxiliary voltage is given by:

$$V_{AUX} = \frac{N_{AUX}}{N_S} \cdot (V_O + V_d) \dots\dots\dots(5)$$

Where V_d is the diode forward drop voltage, N_{AUX} is the turns of auxiliary winding, and N_S is the turns of secondary winding.

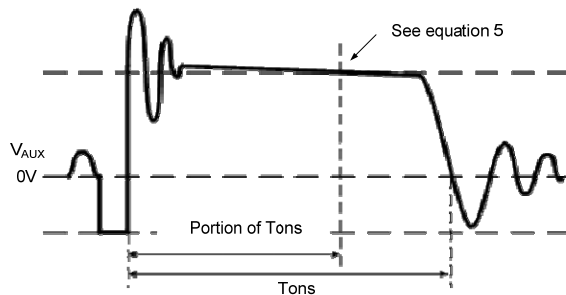

Figure 9. Auxiliary Voltage Waveform

The output voltage is different from the secondary voltage in a diode forward drop voltage V_d which depends on the current. If the secondary voltage is always detected at a constant secondary current, the difference between the output voltage and the secondary voltage will be a fixed V_d . The voltage detection point is portion of T_{ons} after D1 is turned on. The CV loop control function of AP3968D then generates a D1 off-time to regulate the output voltage.

Constant Current Operation

The AP3968D is designed to work in constant current (CC) mode. Figure 10 shows the secondary current waveforms.

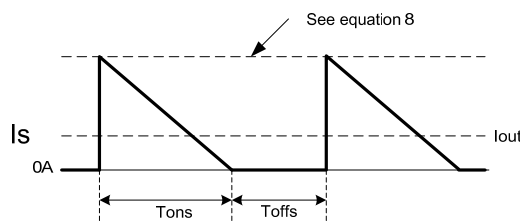

Figure 10. Secondary Current Waveform

In CC operation, the CC loop control function of AP3968D will keep a fixed proportion between D1 on-time T_{ons} and D1 off-time T_{offs} by discharging or

charging the built-in capacitance connected. This fixed proportion is:

$$\frac{T_{ons}}{T_{offs}} = \frac{4}{3} \dots\dots\dots(6)$$

The relation between the output constant-current and secondary peak current I_{pks} is given by:

$$I_{out} = \frac{1}{2} \cdot I_{pks} \cdot \frac{T_{ons}}{T_{ons} + T_{offs}} \dots\dots\dots(7)$$

At the instant of D1 turn-on, the primary current transfers to the secondary at an amplitude of:

$$I_{pks} = \frac{N_P}{N_S} \cdot I_{pk} \dots\dots\dots(8)$$

Thus the output constant current is given by:

$$I_{out} = \frac{2}{7} \cdot \frac{N_P}{N_S} \cdot I_{pk} \dots\dots\dots(9)$$

Leading Edge Blanking (LEB)

When the power switch is turned on, a turn-on spike on the output pulse rising edge will occur on the sense-resistor. To avoid false termination of the switching pulse, a typical 500ns leading edge blanking is built in. During this blanking period, the current sense comparator is disabled and the gate driver can not be switched off.

The built-in LEB in AP3968D has shorter delay time from current sense terminal to output pulse than those IC solutions adopting external RC filter as LEB.

Built-in Cable Compensation

The AP3968D has built-in fixed voltage of 0.35V typical to compensate the drop of output cable when the load is changed from zero to full load. A typical 0.01μF external capacitor connected to the CPC pin is used to smooth voltage signal for cable compensation.

Over Temperature Protection

The AP3968D has internal thermal sensing circuit to shut down the PFM driver output when the die temperature reaches 160°C typical. When the die temperature drops about 40°C, the IC will recover automatically to normal operation.

Typical Application

Figure 11. Typical Application of AP3968D (5V/700mA)

Item	Description	QTY	Item	Description	QTY
C1	10.0 μ F/400V, electrolytic	1	R1	11 Ω , 2W	1
C2	4.7 μ F/400V, electrolytic	1	R3	3.3M Ω /0.25W	1
C3	3.3 μ F/50V, electrolytic	1	R5	3.9 Ω , 0805	1
C5	1nF/1kV, ceramic	1	R6	150k Ω , 1206	1
C8	0.01 μ F, 0805	1	R7	1.3 Ω , 1206	1
C11	1nF, 0805	1	R8	20k Ω , 0805	1
C12	470 μ F/10V	1	R9	13k Ω , 0805	1
D1 to D6	1N4007, rectifier diode	2	R10	200 Ω , 0805	1
D12	APD260	6	R11	27 Ω , 0805	1
L1	470 μ H, inductor	1	R12	1.2k Ω , 0805	1
L2	Bead, 0805	1	T1	EE13 core, PC40, transformer	1
U1	AP3968D	1			

Primary Side Power Switcher for Off-line SMPS

AP3968D

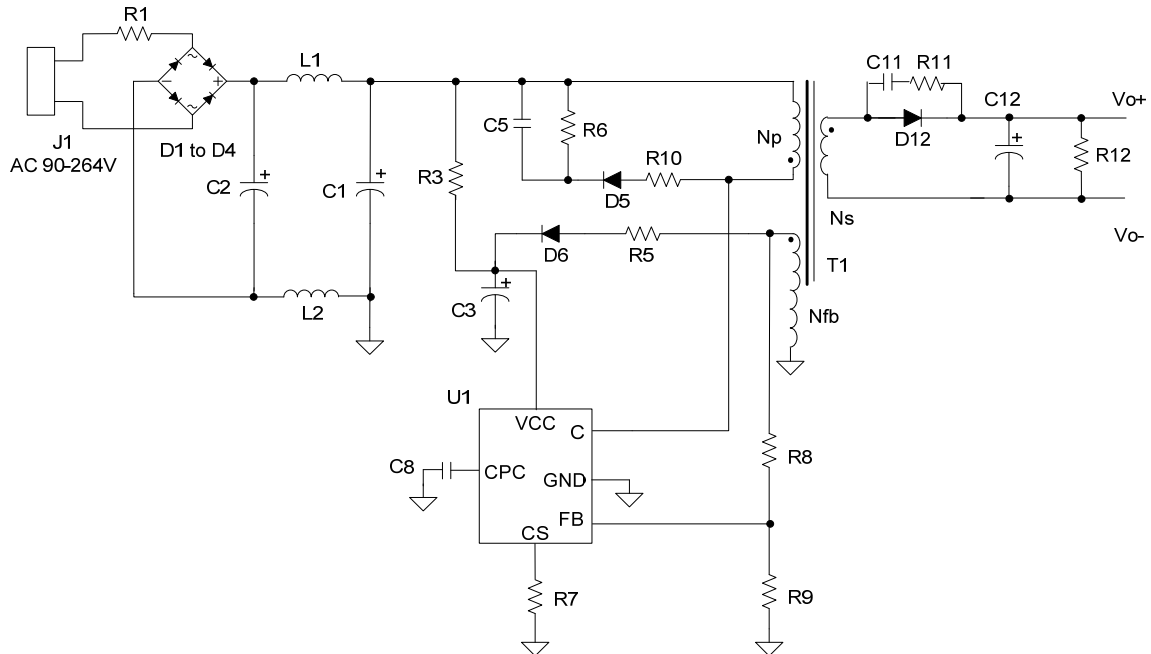
Mechanical Dimensions

SOIC-7

Unit: mm(inch)

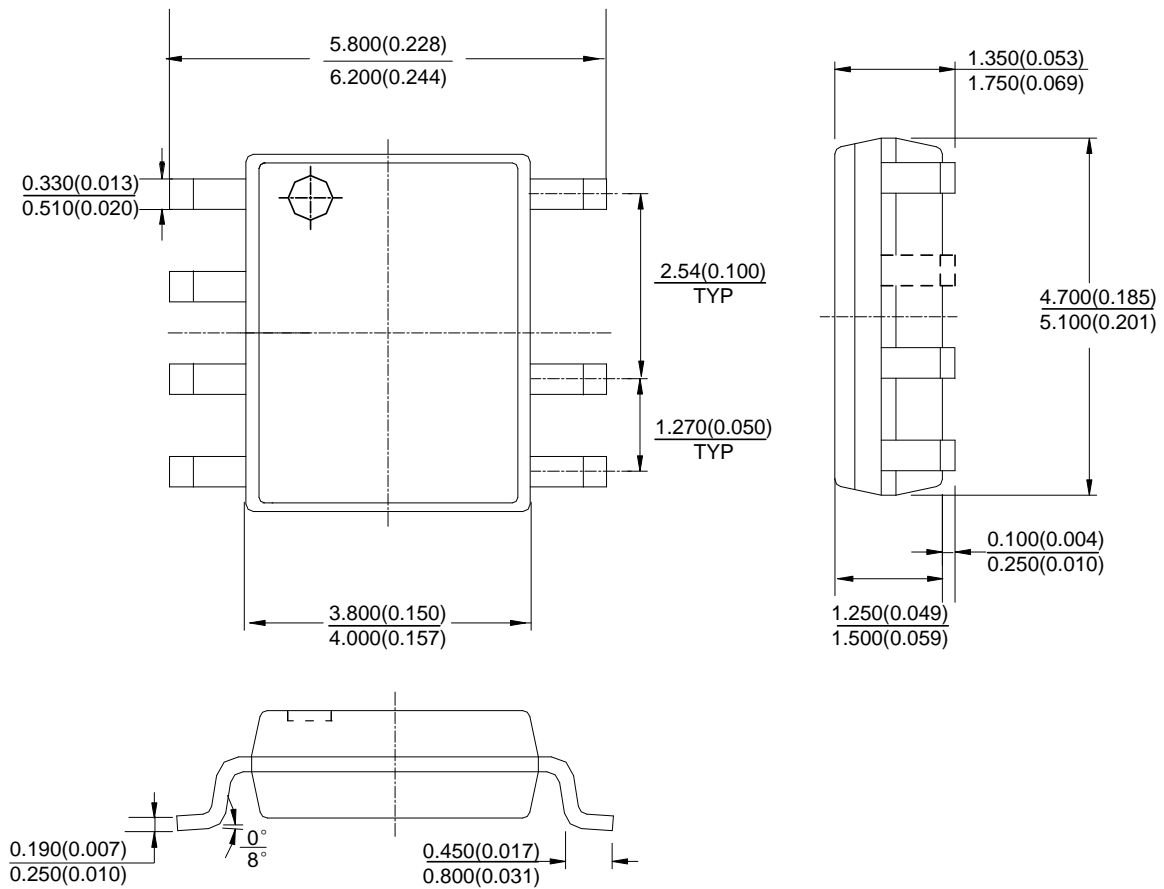

Note: Eject hole, oriented hole and mold mark is optional.



BCD Semiconductor Manufacturing Limited

<http://www.bcdsemi.com>

IMPORTANT NOTICE

BCD Semiconductor Manufacturing Limited reserves the right to make changes without further notice to any products or specifications herein. BCD Semiconductor Manufacturing Limited does not assume any responsibility for use of any its products for any particular purpose, nor does BCD Semiconductor Manufacturing Limited assume any liability arising out of the application or use of any its products or circuits. BCD Semiconductor Manufacturing Limited does not convey any license under its patent rights or other rights nor the rights of others.

MAIN SITE

- Headquarters

BCD (Shanghai) Micro-electronics Limited

No. 1600, Zi Xing Road, Shanghai ZiZhu Science-based Industrial Park, 200241, P. R. C.
Tel: +86-021-2416-2266, Fax: +86-021-2416-2277

- Wafer Fab

Shanghai SIM-BCD Semiconductor Manufacturing Co., Ltd.

800 Yishan Road, Shanghai 200233, China
Tel: +021-6485-1491, Fax: +86-021-5450-0008

REGIONAL SALES OFFICE

Shenzhen Office

Shanghai SIM-BCD Semiconductor Manufacturing Co., Ltd., Shenzhen Office

Unit A Room 1203, Skyworth Bldg., Gaoxin Ave.1.S., Nanshan District
Shenzhen 518057, China

Tel: +86-0755-8660-4900, Fax: +86-0755-8660-4958

Taiwan Office (Taipei)

BCD Semiconductor (Taiwan) Company Limited

3F, No.17, Lane 171, Sec. 2, Jiu-Zong Rd., Nei-Hu Dist., Taipei(114), Taiwan, R.O.C
Tel: +886-2-2656-2808

Fax: +886-2-2656-2806/26562950

Taiwan Office (Hsinchu)

BCD Semiconductor (Taiwan) Company Limited

8F, No.176, Sec. 2, Gong-Dao 5th Road, East District
HsinChu City 300, Taiwan, R.O.C

Tel: +886-3-5160181, Fax: +886-3-5160181

USA Office

BCD Semiconductor Corp.

48460 Kato Road, Fremont, CA 94538, USA
Tel: +1-510-668-1950

Fax: +1-510-668-1990

Korea Office

BCD Semiconductor Limited Korea office.

Room 101-1112, Digital-Empire II, 486 Sin-dong,
Yeongtong-Gu, Suwon-city, Gyeonggi-do, Korea

Tel: +82-31-695-8430

Looking for pricing, stock, or lifecycle information?

Click below to explore more details on WIN SOURCE:

- ⊖ [View AP3968DMTR-G1 on WIN SOURCE](#)
- ⊖ [Diodes Incorporated Information](#)

Optimize Your Supply Chain with WIN SOURCE Solutions

- ✓ Global Sourcing Solution
- ✓ Obsolete Management
- ✓ Cost Control Management
- ✓ Shortage Management
- ✓ Alternative Solution
- ✓ Excess Inventory Management