



**THE DATASHEET OF
TLI49631MXTSA1**



Bipolar Hall Latch

High Precision Hall Effect Latch for 5 V Applications

TLI4963-1M

SP001370094

TLI4963-1M

Data Sheet

Revision 1.2, 2019-12-20

Sense & Control

Table of contents

	Table of contents	2
	List of tables	3
	List of figures	4
1	Product description	5
1.1	Overview	5
1.2	Features	5
1.3	Target applications	6
2	Functional description	7
2.1	General	7
2.2	Pin configuration (top view)	7
2.3	Pin description	7
2.4	Block diagram	8
2.5	Functional block description	9
2.6	Default start-up behavior	10
3	Specification	11
3.1	Application circuit	11
3.2	Absolute maximum ratings	12
3.3	Operating range	13
3.4	Electrical and magnetic characteristics	14
4	Package information	16
4.1	Package outline PG-SOT23-3-15	16
4.2	Packing information PG-SOT23-3-15	16
4.3	Footprint PG-SOT23-3-15	17
4.4	PG-SOT23-3-15 distance between chip and package	17
4.5	Package marking	17
5	Revision history	18

List of tables

Table 1	Ordering information	5
Table 2	Pin description PG-SOT23-3-15	7
Table 3	Absolute maximum rating parameters	12
Table 4	ESD protection ($T_A = 25^\circ\text{C}$)	13
Table 5	Operating conditions parameters	13
Table 6	General electrical characteristics	14
Table 7	Magnetic characteristics	15

List of figures

Figure 1	TLI4963-1M in the PG-SOT23-3-15 package	5
Figure 2	Pin configuration and center of sensitive area.....	7
Figure 3	Functional block diagram TLI4963-1M.....	8
Figure 4	Timing diagram TLI4963-1M.....	9
Figure 5	Output signal TLI4963-1M.....	9
Figure 6	Start-up behavior of the TLI4963-1M	10
Figure 7	Application circuit.....	11
Figure 8	Definition of magnetic field direction PG-SOT23-3-15	15
Figure 9	PG-SOT23-3-15 package outline (all dimensions in mm).....	16
Figure 10	Packing of the PG-SOT23-3-15 in a tape	16
Figure 11	Footprint PG-SOT23-3-15	17
Figure 12	Distance between chip and package	17
Figure 13	Marking of TLI4963-1M.....	17

Product description

1 Product description



1.1 Overview

The TLI4963-1M is a high precision Hall effect sensor with a latch characteristic and highly accurate switching thresholds for operating temperatures up to 125°C.

Characteristic	Supply Voltage	Supply Current	Sensitivity	Interface	Temperature
Hall Effect Latch	3.0 V ~ 5.5 V	1.5 mA	High B_{OP} : 2 mT B_{RP} : -2 mT	Open Drain Output	-40°C to 125°C



Figure 1 TLI4963-1M in the PG-SOT23-3-15 package

1.2 Features

- 3.0 V to 5.5 V operating supply voltage
- Operation from regulated power supply
- Active error compensation
- High stability of magnetic thresholds
- Low jitter (typ. 0.28 μ s)
- 4 kV ESD (HBM) performance
- Small SMD package PG-SOT23-3-15
- For industrial and consumer applications, not qualified for automotive applications
For automotive applications please refer to the Infineon TLE Hall Switches/Latches series

Table 1 Ordering information

Product name	Product type	Ordering code	Package
TLI4963-1M	Bipolar Hall Latch	SP001370094	PG-SOT23-3-15

Product description**1.3 Target applications**

Target applications for the TLI496x Hall Latch family are all applications which require a high precision Hall Latch with an operating temperature range from -40°C to 125°C.

The magnetic behavior as a latch and switching thresholds of typical ± 2 mT make the device especially suited for the use with a pole wheel for index counting applications, e.g. power closing and window lifter or brush less DC motors for commutation.

Functional description

2 Functional description

2.1 General

The TLI4963-1M is an integrated Hall effect latch designed specifically for highly accurate applications where the sensor is connected to a regulated power supply voltage in the range of 3.0V to 5.5V. It provides a temperature stability of the magnetic thresholds.

2.2 Pin configuration (top view)

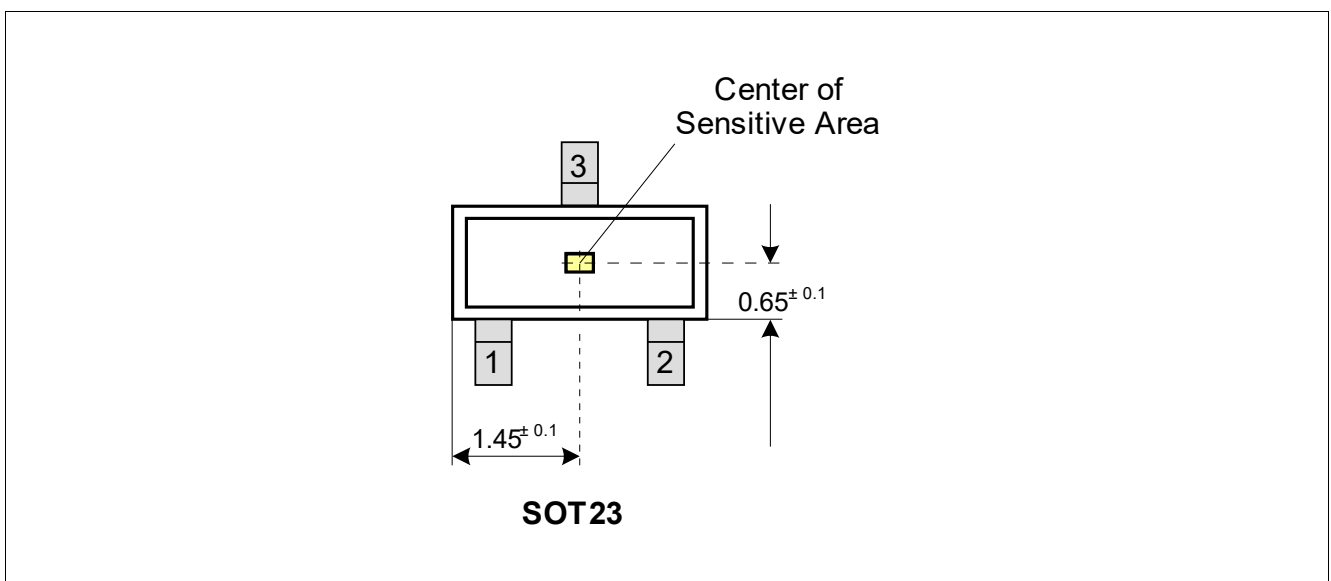

Figure 2 Pin configuration and center of sensitive area

2.3 Pin description

Table 2 Pin description PG-SOT23-3-15

Pin no.	Symbol	Function
1	VDD	Supply voltage
2	Q	Output
3	GND	Ground

Functional description

2.4 Block diagram

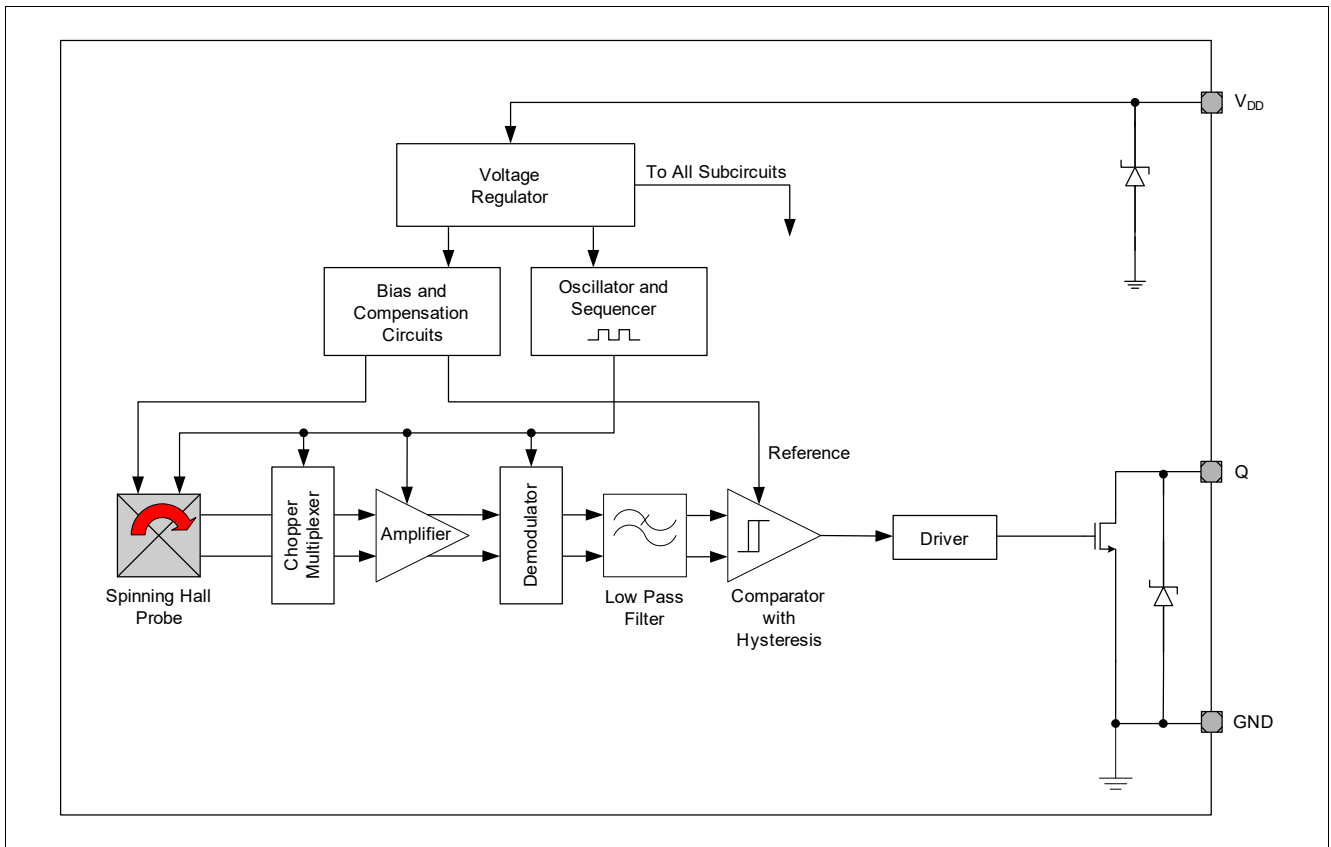

Figure 3 Functional block diagram TLI4963-1M

Functional description

2.5 Functional block description

The chopped Hall IC switch comprises a Hall probe, bias generator, compensation circuits, oscillator and output transistor.

The bias generator provides currents for the Hall probe and the active circuits. Compensation circuits stabilize the temperature behavior and reduce influence of technology variations.

The active error compensation (chopping technique) rejects offsets in the signal path and the influence of mechanical stress to the Hall probe caused by molding and soldering processes and other thermal stress in the package. The chopped measurement principle together with the threshold generator and the comparator ensures highly accurate and temperature stable magnetic thresholds.

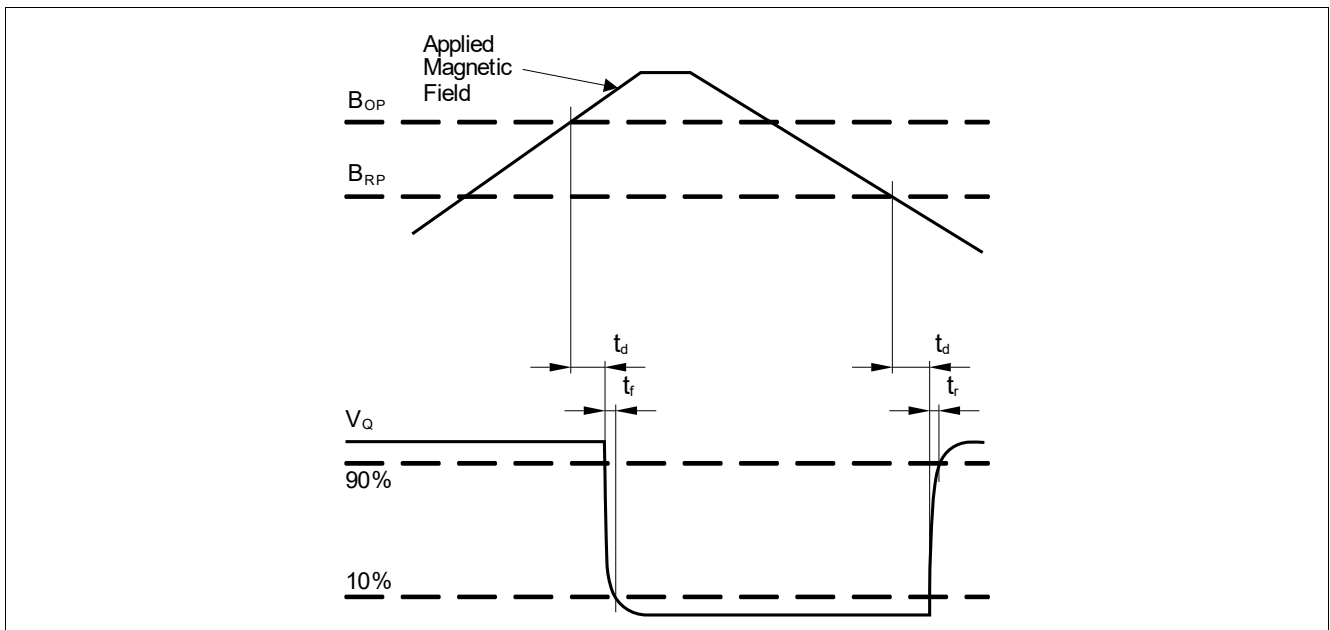

Figure 4 Timing diagram TLI4963-1M

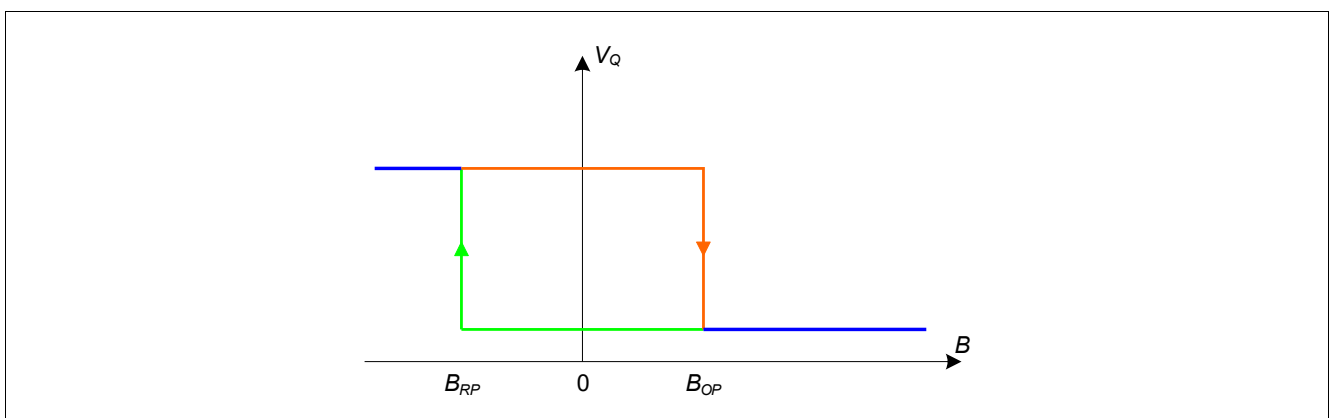

Figure 5 Output signal TLI4963-1M

Functional description

2.6 Default start-up behavior

The magnetic thresholds exhibit a hysteresis $B_{HYS} = B_{OP} - B_{RP}$. In case of a power-on with a magnetic field B within hysteresis ($B_{OP} > B > B_{RP}$) the output of the sensor is set to the pull up voltage level (V_Q) per default. After the first crossing of B_{OP} or B_{RP} of the magnetic field the internal decision logic is set to the corresponding magnetic input value.

V_{DDA} is the internal supply voltage which is following the external supply voltage V_{DD} .

This means for $B > B_{OP}$ the output is switching, for $B < B_{RP}$ and $B_{OP} > B > B_{RP}$ the output stays at V_Q .

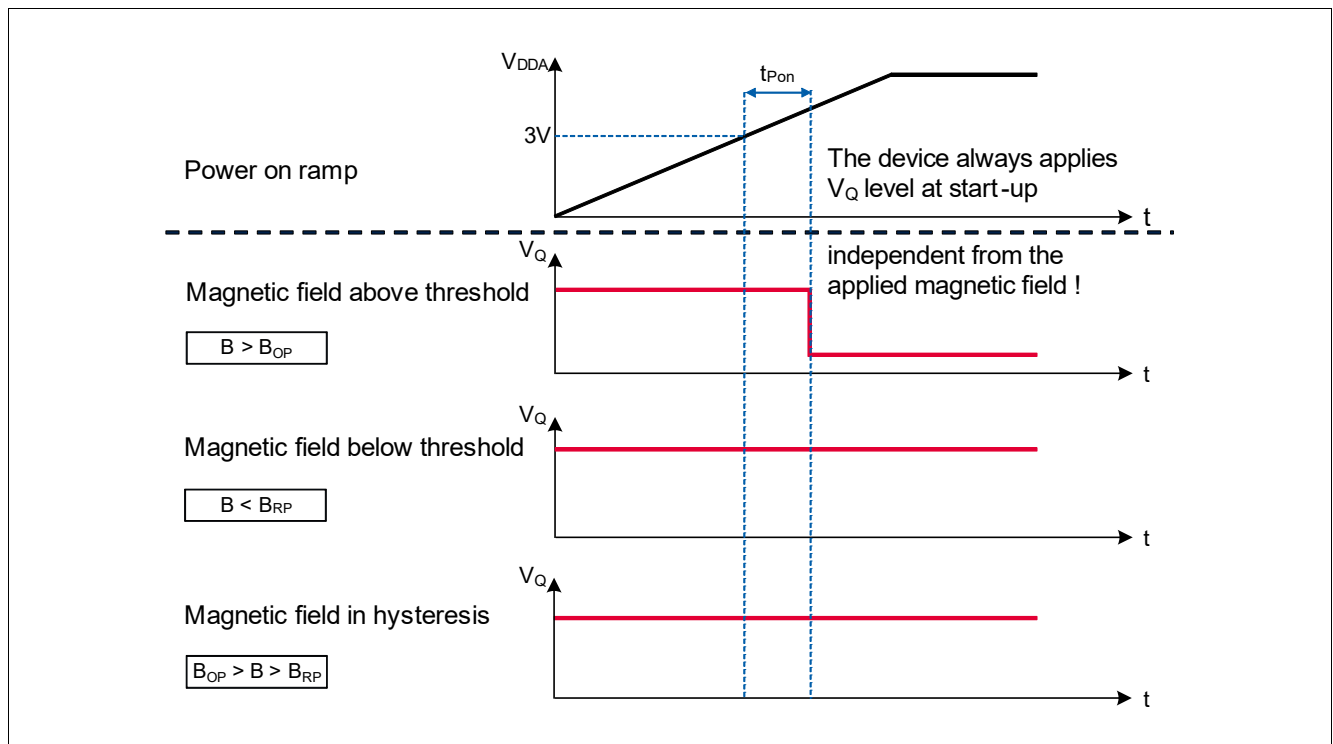

Figure 6 Start-up behavior of the TLI4963-1M

Specification**3 Specification****3.1 Application circuit**

The following **Figure 7** shows one option of an application circuit.

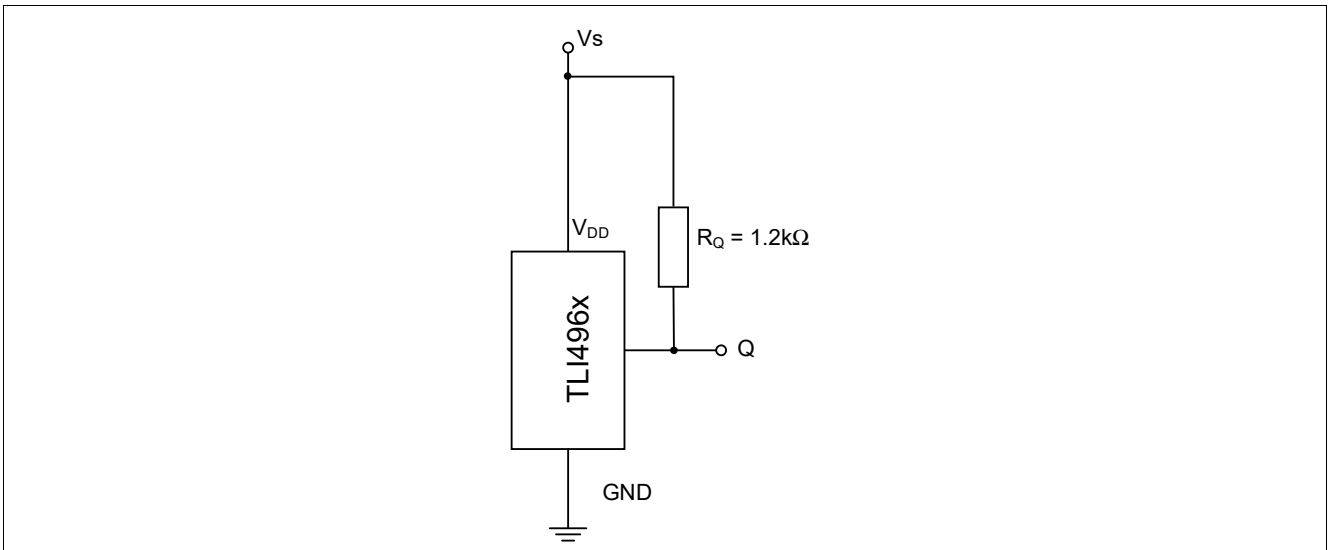

Figure 7 Application circuit

Specification

3.2 Absolute maximum ratings

Table 3 Absolute maximum rating parameters

Parameter	Symbol	Values			Unit	Note or Test Condition
		Min.	Typ.	Max.		
Supply voltage ¹⁾	V_{DD}	-0.3	–	6	V	–
Output voltage	V_Q	-0.5	–	6	V	–
Ambient temperature ¹⁾	T_A	-40	–	150	°C	for 2000h (not additive)
Thermal resistance Junction ambient	R_{thJA}	–	–	300	K/W	for PG-SOT23-3-15 (2s2p)
Thermal resistance Junction lead	R_{thJL}	–	–	100	K/W	for PG-SOT23-3-15

1) This lifetime statement is an anticipation based on an extrapolation of Infineon's qualification test results. The actual lifetime of a component depends on its form of application and type of use etc. and may deviate from such statement. The lifetime statement shall in no event extend the agreed warranty period.

Attention: Stresses above the max. values listed here may cause permanent damage to the device. Exposure to absolute maximum rating conditions for extended periods may affect device reliability. Maximum ratings are absolute ratings; exceeding only one of these values may cause irreversible damage to the integrated circuit.

Calculation of the dissipated power P_{DIS} and junction temperature T_J of the chip (SOT23 example):

e.g. for: $V_{DD} = 5\text{ V}$, $I_S = 2\text{ mA}$, $V_{QSAT} = 0.5\text{ V}$, $I_Q = 1\text{ mA}$

Power dissipation: $P_{DIS} = 5\text{ V} \times 2\text{ mA} + 0.5\text{ V} \times 1\text{ mA} = 10\text{ mW} + 0.5\text{ mW} = 10.5\text{ mW}$

Temperature $\Delta T = R_{thJA} \times P_{DIS} = 300\text{ K/W} \times 10.5\text{ mW} = 3.15\text{ K}$

For $T_A = 150^\circ\text{C}$: $T_J = T_A + \Delta T = 150^\circ\text{C} + 3.15\text{ K} = 153.15^\circ\text{C}$

Specification

Table 4 ESD protection¹⁾ ($T_A = 25^\circ\text{C}$)

Parameter	Symbol	Values			Unit	Note or Test Condition
		Min.	Typ.	Max.		
ESD voltage (HBM) ²⁾	V_{ESD}	-4	-	4	kV	$R = 1.5 \text{ k}\Omega, C = 100 \text{ pF}$
ESD voltage (CDM) ³⁾	V_{ESD}	-1	-	1	kV	-

1) Characterization of ESD is carried out on a sample basis, not subject to production test.

2) Human Body Model (HBM) tests according to ANSI/ESDA/JEDEC JS-001.

3) Charge device model (CDM) tests according to JESD22-C101.

3.3 Operating range

The following operating conditions must not be exceeded in order to ensure correct operation of the TLI4963-1M.

All parameters specified in the following sections refer to these operating conditions unless otherwise mentioned.

The maximum tested magnetic field is 600 mT.

Table 5 Operating conditions parameters

Parameter	Symbol	Values			Unit	Note or Test Condition
		Min.	Typ.	Max.		
Supply voltage	V_{DD}	3.0	-	5.5	V	-
Output voltage	V_{Q}	-0.3	-	5.5	V	-
Ambient temperature	T_A	-40	-	125	$^\circ\text{C}$	-
Output current	I_{Q}	0	-	5	mA	-
Magnetic signal input frequency ¹⁾	f_{SW}	0	-	10	kHz	-

1) For operation at the maximum switching frequency the magnetic input signal must be 1.4 times higher than for static fields. This is due to the -3 dB corner frequency of the internal low-pass filter in the signal path.

Specification

3.4 Electrical and magnetic characteristics

Product characteristics involve the spread of values guaranteed within the specified voltage and ambient temperature range. Typical characteristics are the median of the production and correspond to $V_{DD} = 5\text{ V}$ and $T_A = 25^\circ\text{C}$. The below listed specification is valid in combination with the application circuit shown in [Figure 7](#).

Table 6 General electrical characteristics

Parameter	Symbol	Values			Unit	Note or Test Condition
		Min.	Typ.	Max.		
Supply current	I_S	1.1	1.5	2.5	mA	–
Reverse current ¹⁾	I_{SR}	–	–	2.5	mA	for $V_{DD} = -0.3\text{ V}$ and 125°C
Output saturation voltage	V_{QSAT}	–	0.2	0.5	V	$I_Q = 5\text{ mA}$
Output leakage current	I_{QLEAK}	–	–	10	μA	–
Output fall time ¹⁾	t_f	0.17	0.24	1	μs	1.2 k Ω / 50 pF, see Figure 4
Output rise time ¹⁾	t_r	0.4	0.5	1	μs	1.2 k Ω / 50 pF, see Figure 4
Output jitter ¹⁾²⁾	t_{QJ}	–	0.28	1	μs	for square wave signal with 1 kHz
Delay time ¹⁾³⁾	t_d	11.5	15	30	μs	see Figure 4
Power-on time ¹⁾⁴⁾	t_{PON}	–	50	100	μs	$V_{DD} = 3\text{ V}$, $B \leq B_{RP} - 0.5\text{ mT}$ or $B \geq B_{OP} + 0.5\text{ mT}$
Chopper frequency ¹⁾	f_{OSC}	–	350		kHz	–

- 1) Not subject to production test, verified by design/characterization.
- 2) Output jitter is the 1σ value of the output switching distribution.
- 3) Systematic delay between magnetic threshold reached and output switching.
- 4) Time from applying $V_{DD} = 3.0\text{ V}$ to the sensor until the output is valid.

Specification

Table 7 Magnetic characteristics

Parameter	Symbol	T (°C)	Values			Unit	Note / Test Condition
			Min.	Typ.	Max.		
Operating point	B_{OP}	-40	0.6	2.2	3.7	mT	-
		25	0.5	2.0	3.5		
		125	0.3	1.7	3.1		
Release point	B_{RP}	-40	-3.7	-2.2	-0.6	mT	-
		25	-3.5	-2.0	-0.5		
		125	-3.1	-1.7	-0.3		
Hysteresis	B_{HYS}	-40	2.8	4.4	5.7	mT	-
		25	2.6	4.0	5.4		
		125	2.2	3.4	4.6		
Effective noise value of the magnetic switching points ¹⁾²⁾	B_{Neff}	25	-	39	-	μT	-
Temperature compensation of magnetic thresholds ²⁾	T_C	-	-	-1500	-	ppm/K	-

- 1) The magnetic noise is normal distributed and can be assumed as nearly independent to frequency without sampling noise or digital noise effects. The typical value represents the rms-value and corresponds therefore to a 1 σ probability of normal distribution. Consequently a 3 σ value corresponds to 0.3% probability of appearance.
- 2) Not subject to production test, verified by design/characterization.

Field direction definition

Positive magnetic fields are defined with the south pole of the magnet to the branded side of package.

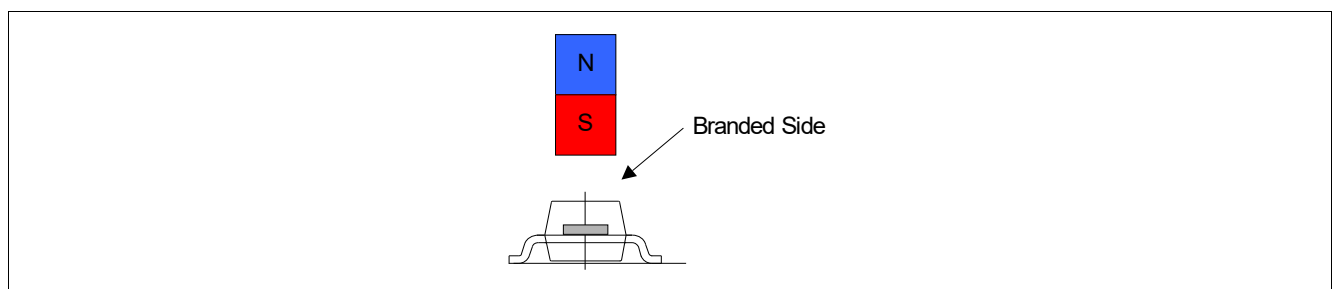

Figure 8 Definition of magnetic field direction PG-SOT23-3-15

Package information

4 Package information

The TLI4963-1M is available in the small halogen-free SMD package PG-SOT23-3-15.

4.1 Package outline PG-SOT23-3-15

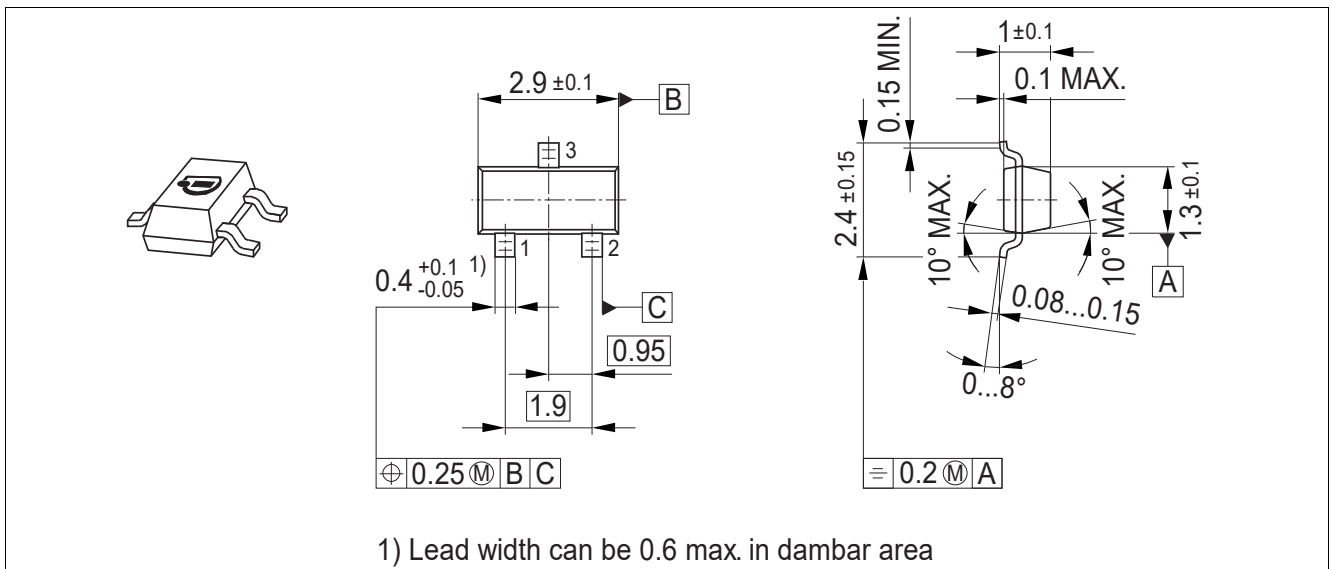

Figure 9 PG-SOT23-3-15 package outline (all dimensions in mm)

4.2 Packing information PG-SOT23-3-15

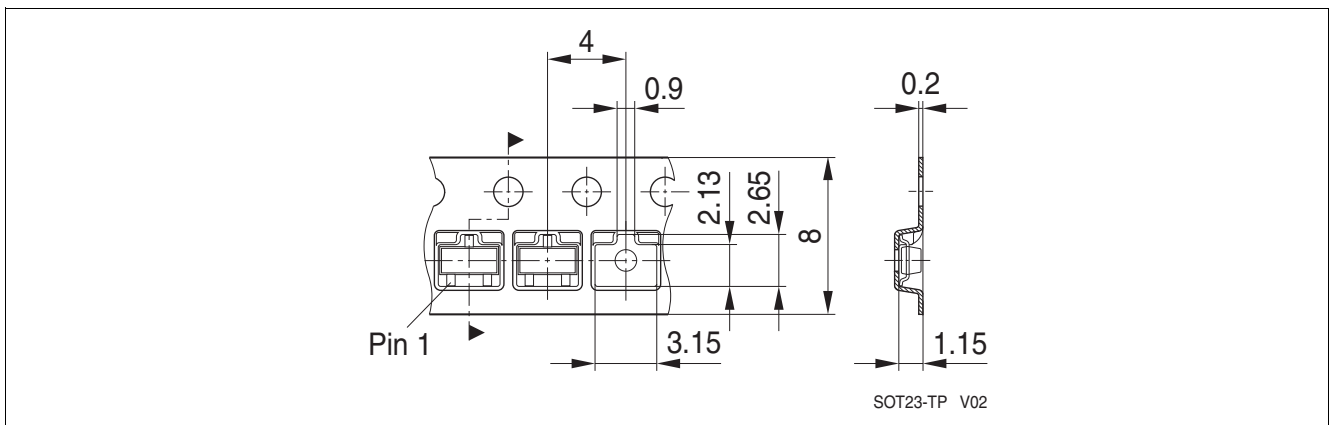

Figure 10 Packing of the PG-SOT23-3-15 in a tape

Package information

4.3 Footprint PG-SOT23-3-15

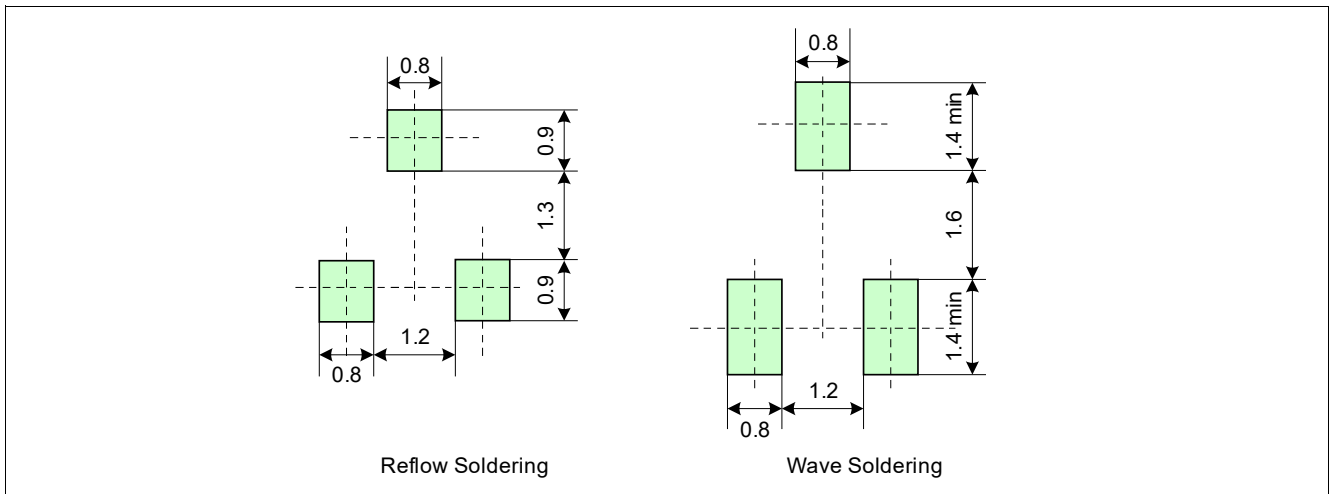

Figure 11 Footprint PG-SOT23-3-15

4.4 PG-SOT23-3-15 distance between chip and package

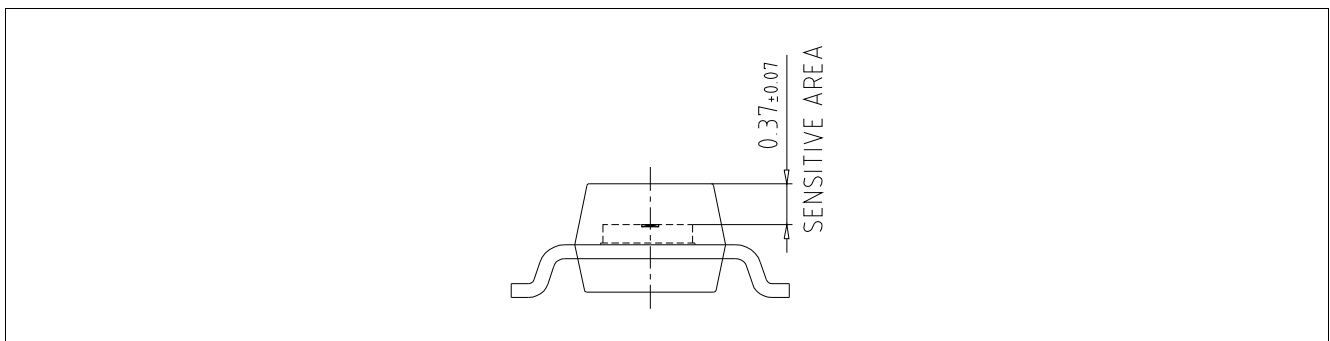

Figure 12 Distance between chip and package

4.5 Package marking

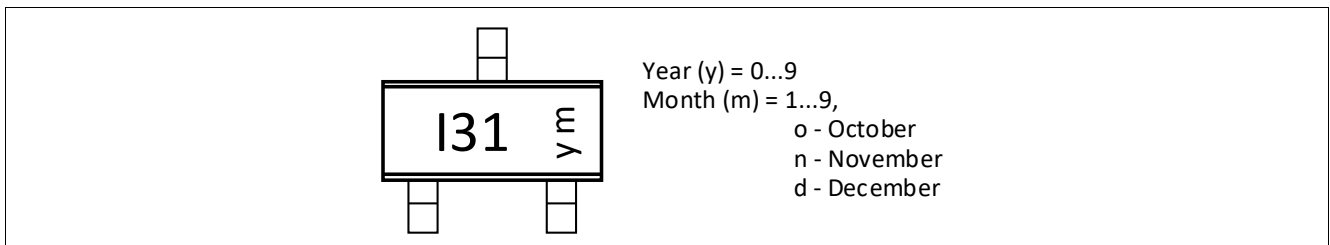

Figure 13 Marking of TLI4963-1M

Revision history**5 Revision history**

Revision	Date	Changes
Revision 1.2	2019-12-20	Updated text and figure in Chapter 2.6 Updated standards in Table 4 Added maximum tested magnetic field in Chapter 3.3 Updated Figure 12 Editorial changes
Revision 1.0	2016-01-11	Initial release

Trademarks

All referenced product or service names and trademarks are the property of their respective owners.

www.infineon.com

Edition 2019-12-20

Published by

Infineon Technologies AG

81726 Munich, Germany

© 2019 Infineon Technologies AG.

All Rights Reserved.

Do you have a question about any aspect of this document?

Email: erratum@infineon.com

Document reference

Legal Disclaimer

The information given in this document shall in no event be regarded as a guarantee of conditions or characteristics. With respect to any examples or hints given herein, any typical values stated herein and/or any information regarding the application of the device, Infineon Technologies hereby disclaims any and all warranties and liabilities of any kind, including without limitation, warranties of non-infringement of intellectual property rights of any third party.

Information

For further information on technology, delivery terms and conditions and prices, please contact the nearest Infineon Technologies Office (www.infineon.com).

Warnings

Due to technical requirements, components may contain dangerous substances. For information on the types in question, please contact the nearest Infineon Technologies Office. Infineon Technologies components may be used in life-support devices or systems only with the express written approval of Infineon Technologies, if a failure of such components can reasonably be expected to cause the failure of that life-support device or system or to affect the safety or effectiveness of that device or system. Life support devices or systems are intended to be implanted in the human body or to support and/or maintain and sustain and/or protect human life. If they fail, it is reasonable to assume that the health of the user or other persons may be endangered.

Looking for pricing, stock, or lifecycle information?

Click below to explore more details on WIN SOURCE:

- ⊖ [View TLI49631MXTSA1 on WIN SOURCE](#)
- ⊖ [Infineon Technologies Information](#)

Optimize Your Supply Chain with WIN SOURCE Solutions

- ✓ Global Sourcing Solution
- ✓ Obsolete Management
- ✓ Cost Control Management
- ✓ Shortage Management
- ✓ Alternative Solution
- ✓ Excess Inventory Management