



**THE DATASHEET OF  
ISL91211AIK-REFZ**



# ISL91211A-BIK-REFZ, ISL91211AIK-REFZ, ISL91211BIK-REF2Z

## User's Manual: Reference Boards

Core Power Solutions

All information contained in these materials, including products and product specifications, represents information on the product at the time of publication and is subject to change by Renesas Electronics Corp. without notice. Please review the latest information published by Renesas Electronics Corp. through various means, including the Renesas Electronics Corp. website (<http://www.renesas.com>).

## ISL91211A-BIK-REFZ, ISL91211AIK-REFZ, ISL91211BIK-REF2Z

### Reference Boards

The Renesas Xilinx FPGA reference board is an expandable power supply designed to provide the various Xilinx power rails to the Xilinx Artix-7, Spartan-7, and Zynq-7000 families. The design uses the power source from the DC power supply or a plug-in AC/DC adapter to the barrel jack of this reference board.

The ISL91211AIK and ISL91211BIK provide four independent One Time Programmable (OTP) voltage defaults for each buck output. This flexibility supports an expandable and optimized power supply from a Xilinx high-end product to a low-end product. This reference board is designed specifically to solve the complex FPGAs and SoC devices. You can combine this reference design with your Xilinx FPGA or SoC motherboard platform.

### Key Features

- 5V AC/DC adapter or DC power input
- Power outputs support different skews Xilinx Artix-7, Spartan-7, and Zynq-7000 FPGAs
- Supports different output voltages through DVS control signals (pull-up/down resistors)
- Complete power validation hardware and software tools – I<sup>2</sup>C interface and Power Navigator (GUI)
- Design files and documents are available to minimize system design efforts

### Ordering Information

Part Number	Description
ISL91211A-BIK-REFZ	Renesas Xilinx Artix-7 (XC7A200T) reference board
ISL91211AIK-REFZ	Renesas Xilinx Zynq-7000 reference board
ISL91211BIK-REF2Z	Renesas Xilinx Spartan-7 Reference board

### Related Literature

For a full list of related documents, visit our website:

- [ISL91211AIK](#), [ISL91211BIK](#), [ISL21010DFH312](#), [ISL9123](#), [ISL80030](#) device pages

# 1. Functional Description

## 1.1 Power-Up Sequencing

The Xilinx Artix-7/Vertex-7/Zynq-7000 power sequence begins by turning on a mechanical switcher. When the input voltage ramps up and is stable, it triggers Power Enable signals (EN\_1/EN\_VCCIO\_2V5/EN\_VCCIO\_3V3) with a timely order by an external RC time constant to the system, which is generated by turning on the mechanical switcher. The ISL91211AIK and the ISL91211BIK have an internal 1.4ms boot-up delay after EN\_1 is asserted. The internal power delays (set by OTP) provide the necessary delays based on the Xilinx FPGA requirements. The timing diagram for the power sequencing is shown in [Figure 1](#).

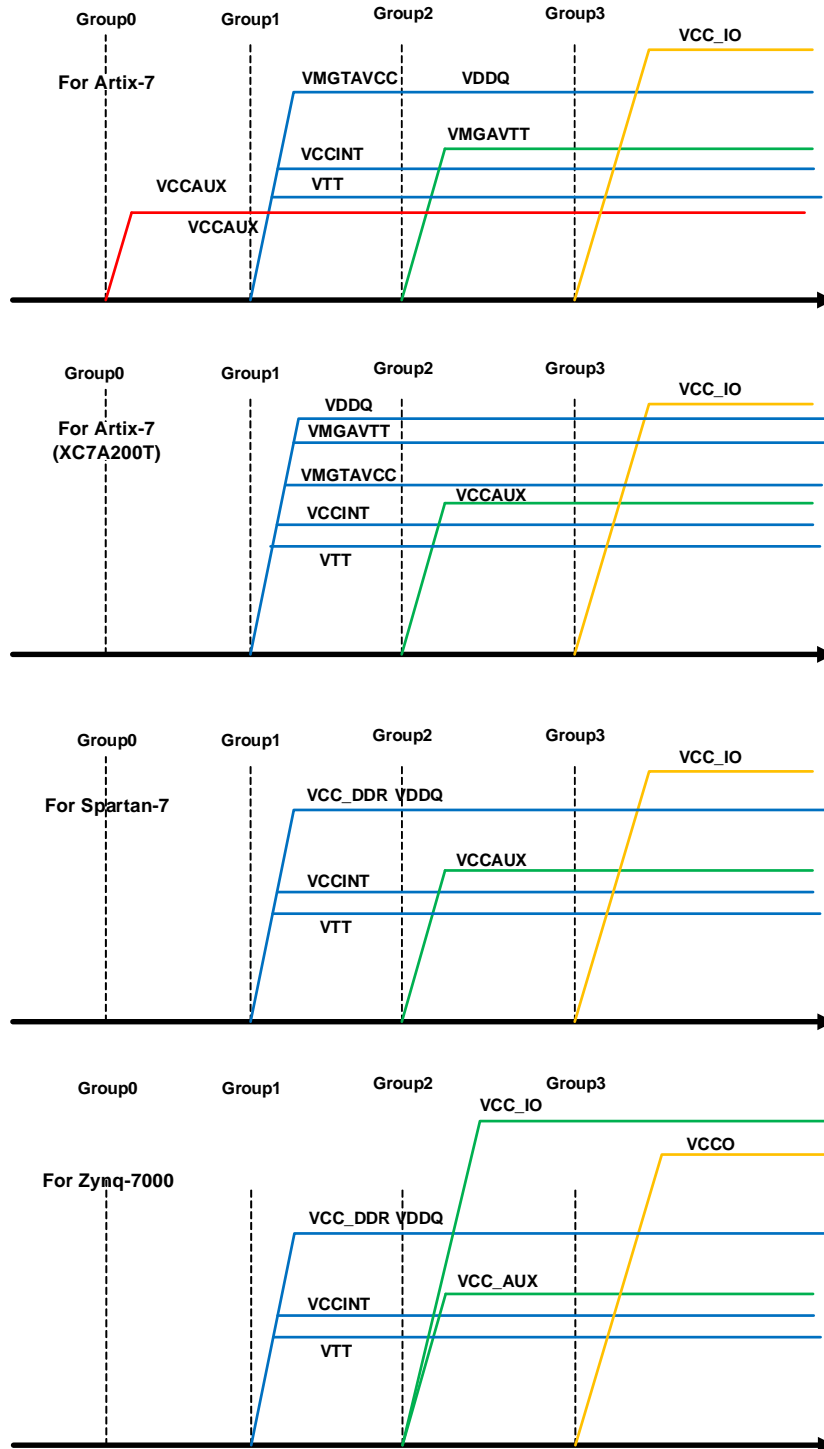

Figure 1. Xilinx Power-Up Sequence

## 1.2 Power Block Diagram

This Renesas FPGA reference board supports Xilinx Artix-7, Spartan-7, and Zynq-7000. The ISL91211AIK and ISL91211BIK are able to provide the multiple power rails for VCCINT, VCCAUX, VMGTAVTT, VMGTAVCC, and DDR3/DDR4/LPDDR2/LPDDR3/DDR3L by choosing the DVS option. The solution size for each reference board can be estimated with the silkscreen for the solution. To meet the recommended power-on sequence to achieve minimum current draw for VCCINT, VMGTAVCC, and VMGTAVTT, the power-up sequence is provided in a timely manner.

The ISL91211AIK and ISL91211BIK have four independently programmable voltage settings for each buck controller, that can be used to set the output voltage. They are DVS0, DVS1, DVS2, and DVS3. By changing the DVS number selected, the corresponding output voltage is selected. To configure DVS, DVS\_PIN1(MPIO1), and DVS\_PIN0(MPIO0), set the active DVS by setting IO\_PINMODE = 0x4, which is in combination with BUCKx\_DVSPIN\_CTRL[1:0] = 0x3 (OTP factory value) in the BUCKx\_DVSCFG register.

**Table 1. Global DVS Pin Logic**

DVS_PIN1 (MPIO1)	DVS_PIN0 (MPIO0)	Active DVS
0	0	DVS0
0	1	DVS1
1	0	DVS2
1	1	DVS3

### 1.3 Renesas FPGA Power Evaluation Board Outline

The evaluation board is classified into four different Xilinx FPGA applications, such as Artix-7, Artix-7(XC7A200T), Spartan-7, and Zynq-7000. The Artix-7 application requires the ISL91211AIK and ISL91211BIK PMICs, although the Spartan-7 and Zynq-7000 need only one PMIC. See [Figure 2](#).

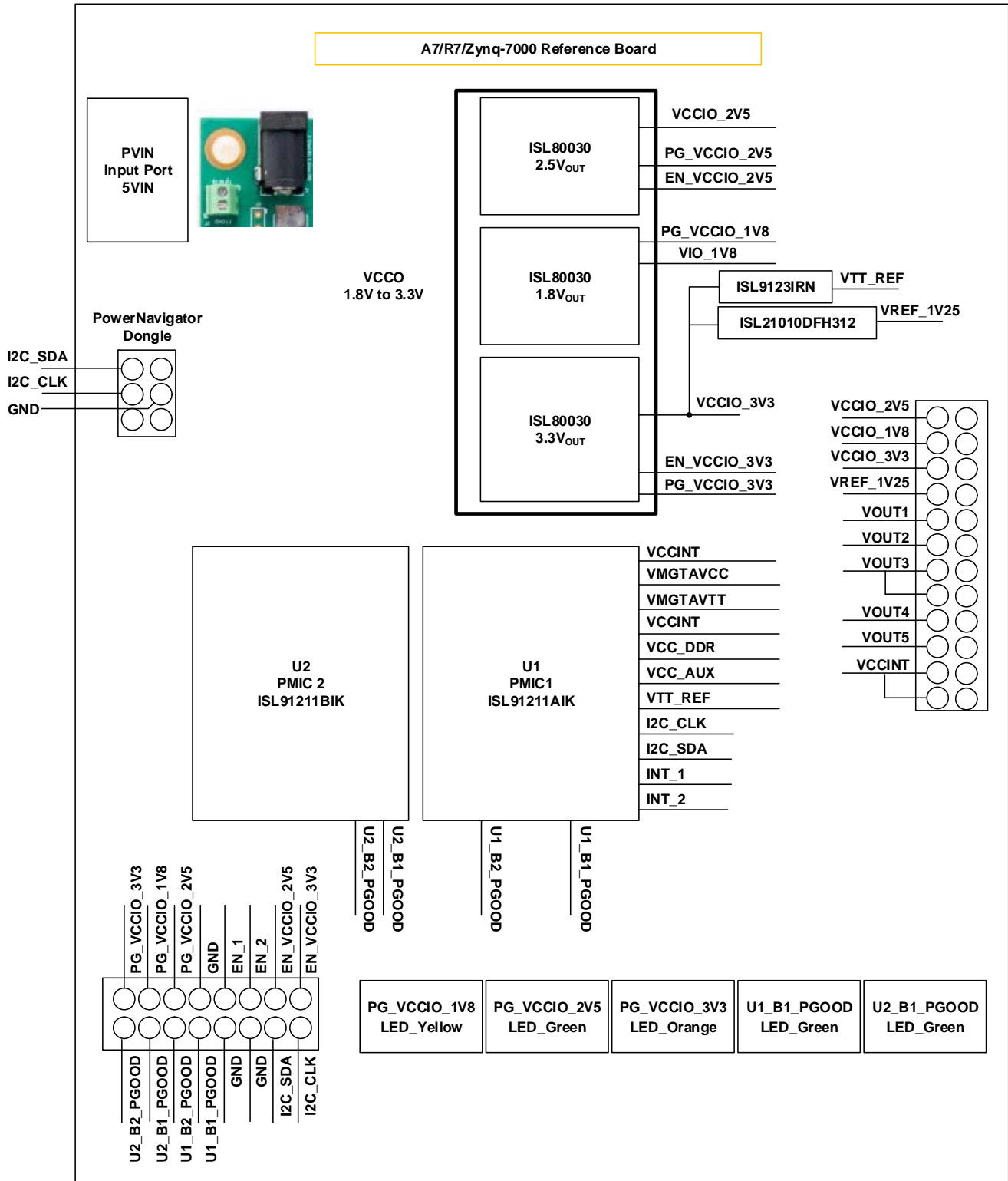

Figure 2. Renesas Evaluation Board Outline for Xilinx Artix-7/Spartan-7/Zynq-7000 FPGA

### 1.3.1 Artix-7 FPGA

Highlights for Artix-7 FPGA solution:

- The reference board uses 5V input from a plug-in AC/DC (5V) adapter or DC power supply
- The ISL91211BIK is required for multiple power rails
- Optional ISL21010DFH312 is for XADC input voltage, 1.25V ±0.2% accuracy
- The ISL80030 supports VCCO and VCC\_IO, 3.3V/2.5V/1.8V

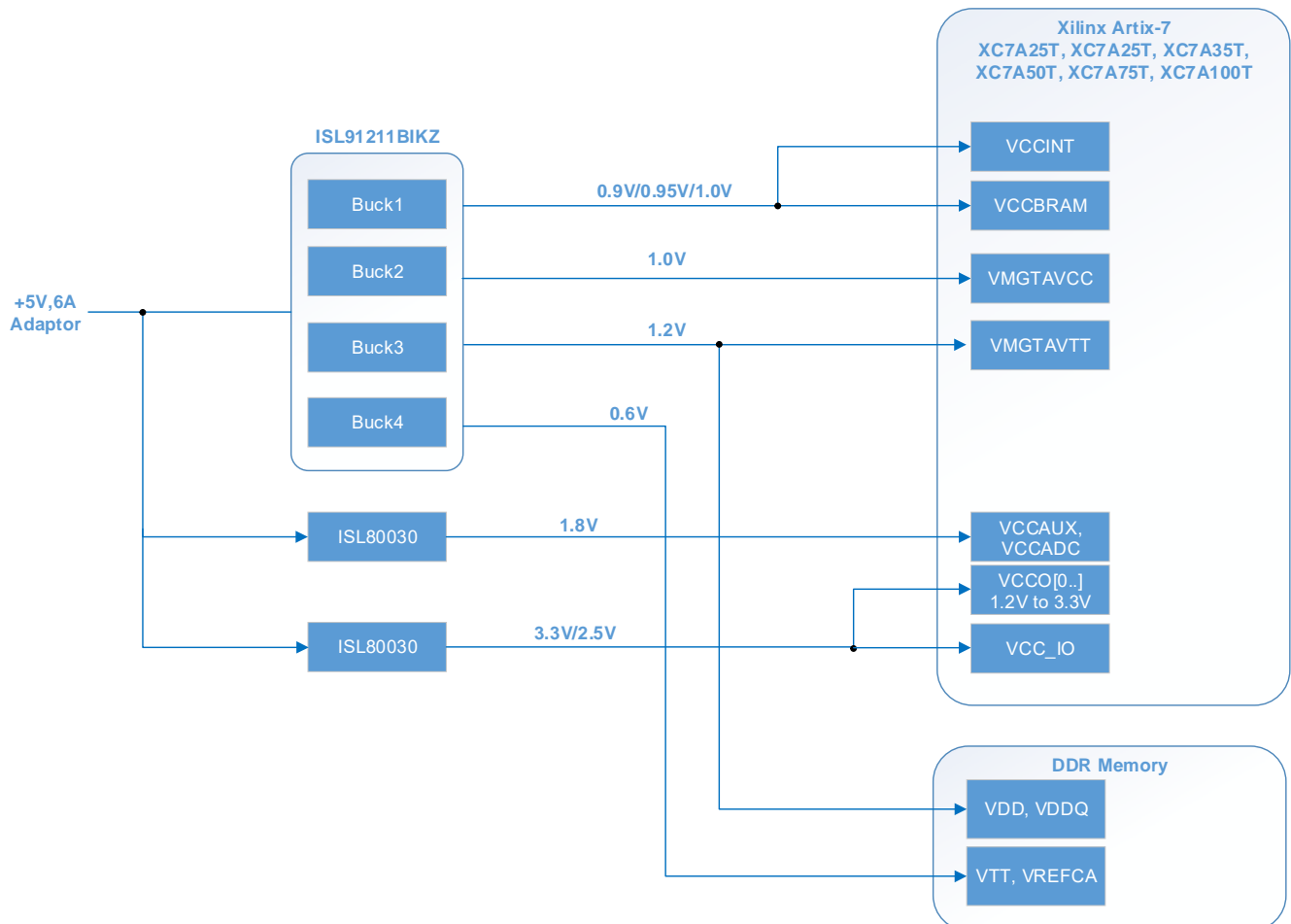

Figure 3. Artix-7 FPGA Block Diagram

Table 2. ISL91211BIKZ-TR5877 DVS Output Option for Artix-7 Power Rail

Artix-7 Rail	ISL91211BIK (1+1+1+1)	ISL91211BIKZ-TR5877 (I <sup>2</sup> C Slave Address = 0x62)		
	DVS_PIN1/DVS_PIN0	00	01	11
VCCINT	VOUT1	0.90V	0.95V	1.0V
VMGTAVCC	VOUT2	1.0V	1.0V	1.0V
VMGAVTT, VDDQ	VOUT3	1.2V	1.2V	1.2V
VTT	VOUT4	0.6V	0.6V	0.6V

### 1.3.2 Artix-7(XC7A200T) FPGA

Highlights for Artix-7(XC7A200T) FPGA solution:

- A high-performance Xilinx Artix-7 XC7A200T solution
- The reference board uses 5V input from a plug-in AC/DC (5V) adapter or DC power supply
- The ISL91211AIK and ISL91211BIK are required for multiple power rails
- Optional ISL21010DFH312 is for XADC input voltage, 1.25V  $\pm$ 0.2% accuracy
- The ISL80030 supports VCCO and VCC\_IO, 3.3V/2.5V/1.8V

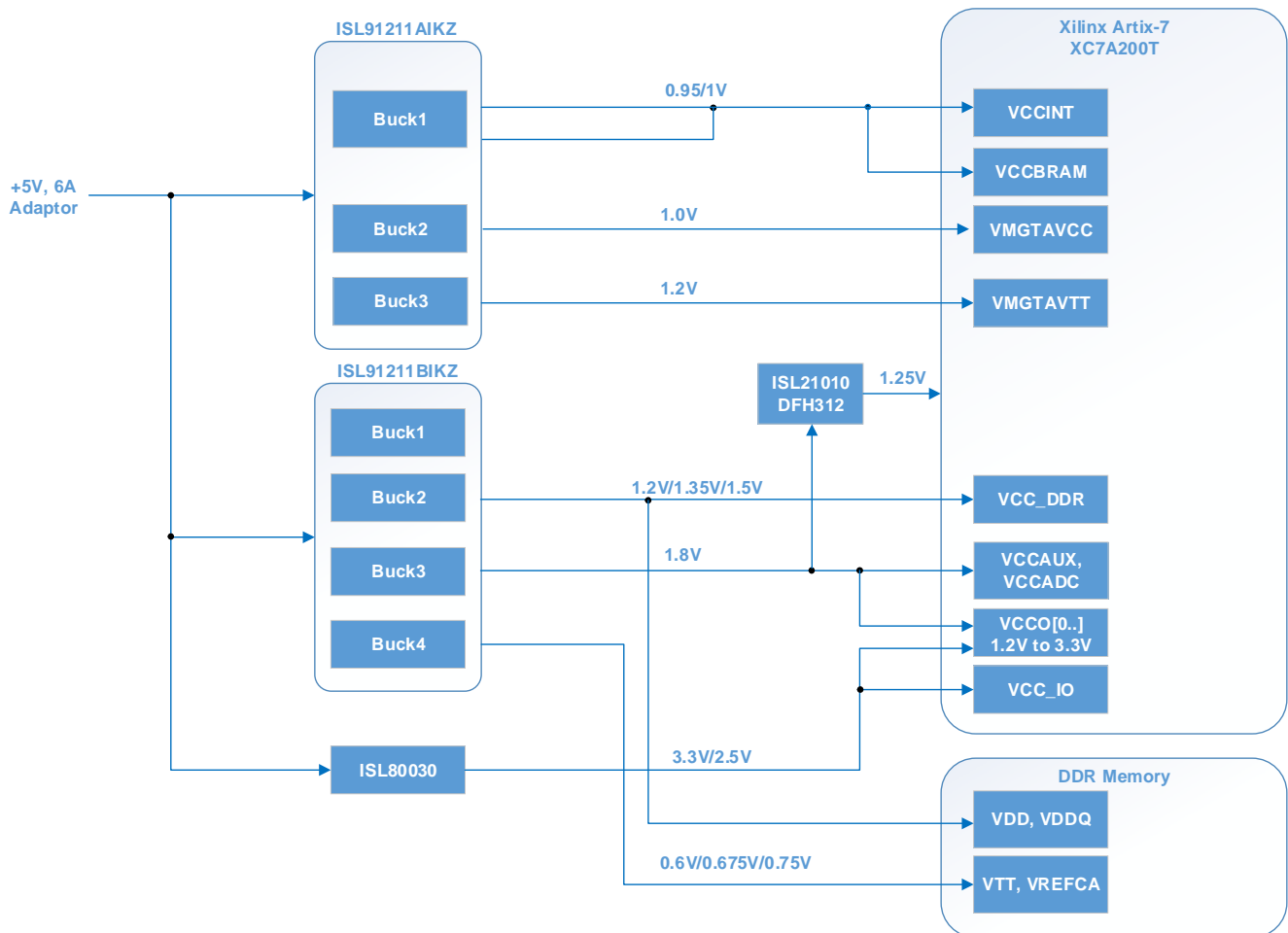

Figure 4. Artix-7 FPGA Block Diagram

Table 3. ISL91211AIKZ-TR5873 DVS Output Option for Artix-7 (XC7A200T) Power Rail

Artix-7 Rail	ISL91211AIK (2+1+1)		ISL91211AIKZ-TR5873 (I <sup>2</sup> C Slave Address = 0x60)	
	DVS_PIN1/DVS_PIN0		00	01
VCCINT, VCCBRAM	VOUT1		0.95V	1.0V
VMGTAVCC	VOUT2		1.0V	1.0V
VMGTAVTT	VOUT3		1.2V	1.2V

**Table 4. ISL91211BIKZ-TR5875 and ISL91211BIKZ-TR5876 DVS Output Option for Artix-7(XC7A200T) Power Rail**

Artix-7 Rail	ISL91211BIK (1+1+1+1)	ISL91211BIKZ-TR5875 (I <sup>2</sup> C Slave Address = 0x62)				ISL91211BIKZ-TR5876 (I <sup>2</sup> C Slave Address = 0x62)			
	DVS_PIN1/DVS_PIN0	00	01	10	11	00	01	10	11
Reserved	VOUT1	Off	Off	Off	Off	Off	Off	Off	Off
VDDQ	VOUT2	1.35V	1.35V	1.5V	1.5V	1.2V	1.2V	1.5V	1.5V
VCCAUX/ADC	VOUT3	1.8V	1.8V	1.8V	1.8V	1.8V	1.8V	1.8V	1.8V
VTT	VOUT4	0.675V	0.675V	0.75V	0.75V	0.6V	0.6V	0.75V	0.75V

### 1.3.3 Spartan-7 FPGA

Highlights for Spartan-7 FPGA solution:

- The reference board uses 5V input from a plug-in AC/DC (5V) adaptor or DC power supply
- The ISL91211BIK is required for VCCINT, VCCBRAM, VCC\_DDR, VCCAUX, and VTT
- The ISL80030 supports VCCO and VCC\_IO, 3.3V/2.5V

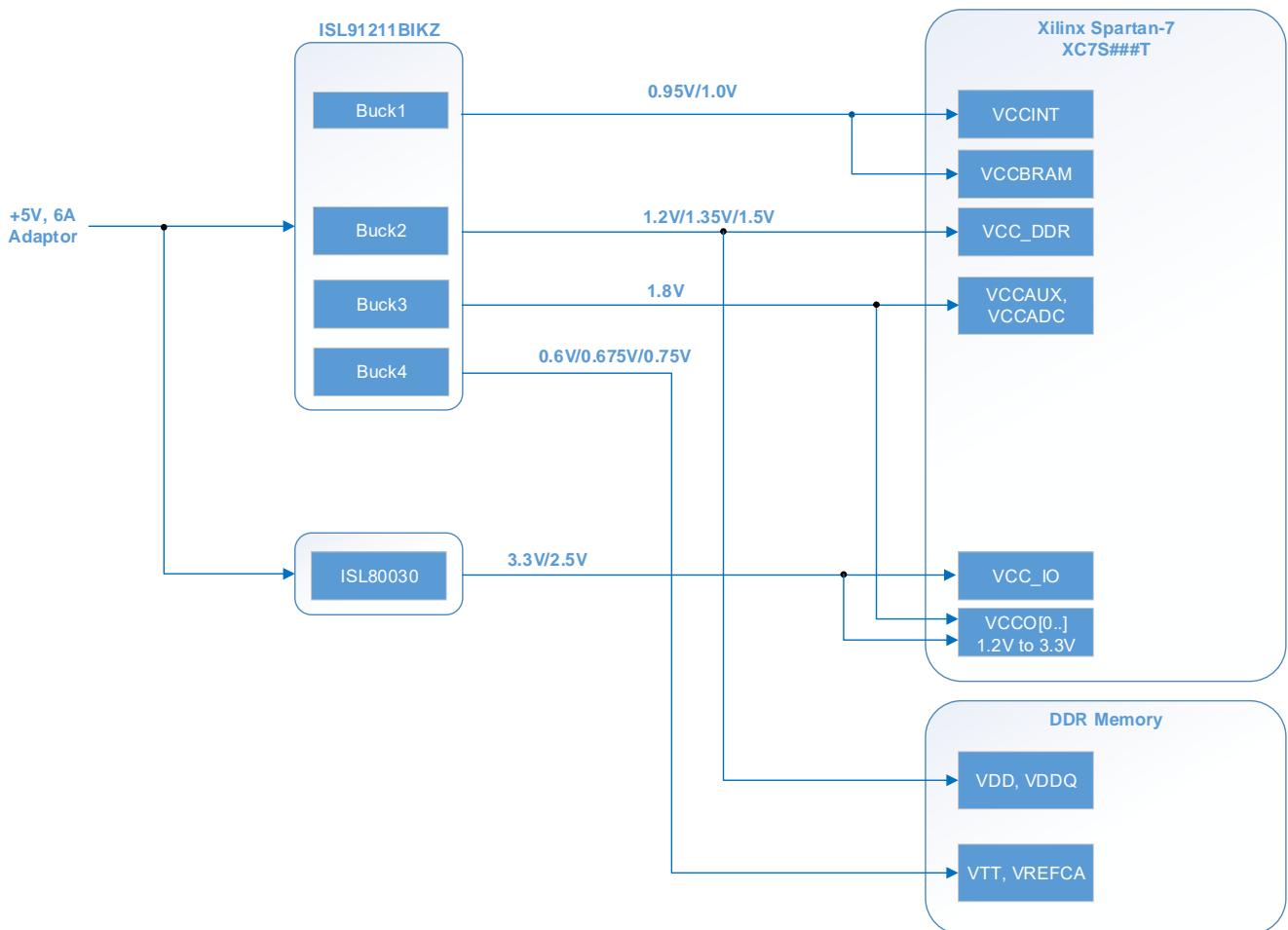

**Figure 5. Spartan-7 FPGA Block Diagram**

**Table 5. ISL91211BIKZ-TR5878 and ISL91211BIKZ-TR5879 DVS Output Option for Spartan-7 Power Rail**

Spartan-7 Rail	ISL91211BIK (1+1+1+1)	ISL91211BIKZ-TR5878 (I <sup>2</sup> C Slave Address = 0x62)			
	DVS_PIN1/DVS_PIN0	00	01	10	11
VCCINT	VOUT1	0.95V	1.0V	0.95V	1.0V
VCC_DDR	VOUT2	1.35V	1.35V	1.5V	1.5V
VCCAUX/ADC	VOUT3	1.8V	1.8V	1.8V	1.8V
VTT	VOUT4	0.675V	0.675V	0.75V	0.75V

Spartan-7 Rail	ISL91211BIK (1+1+1+1)	ISL91211BIKZ-TR5879 (I <sup>2</sup> C Slave Address = 0x62)			
	DVS_PIN1/DVS_PIN0	00	01	10	11
VCCINT	VOUT1	0.95V	1.0V	0.9V	0.9V
VCC_DDR	VOUT2	1.2V	1.2V	1.35V	1.35V
VCCAUX/ADC	VOUT3	1.8V	1.8V	1.8V	1.8V
VTT	VOUT4	0.6V	0.6V	0.675V	0.675V

### 1.3.4 Zynq-7000 FPGA

Highlights for Spartan-7 FPGA solution:

- The reference board uses 5V input from a plug-in AC/DC (5V) adapter or DC power supply
- The ISL91211AIK is required for VCCINT, VCCBRAM, VCC\_DDR, and VCCAUX
- Optional ISL21010DFH312 is required for XADC, 1.25V ±0.2% accuracy
- The ISL80030 supports VCCO and VCC\_IO, 3.3V/2.5V/1.8V

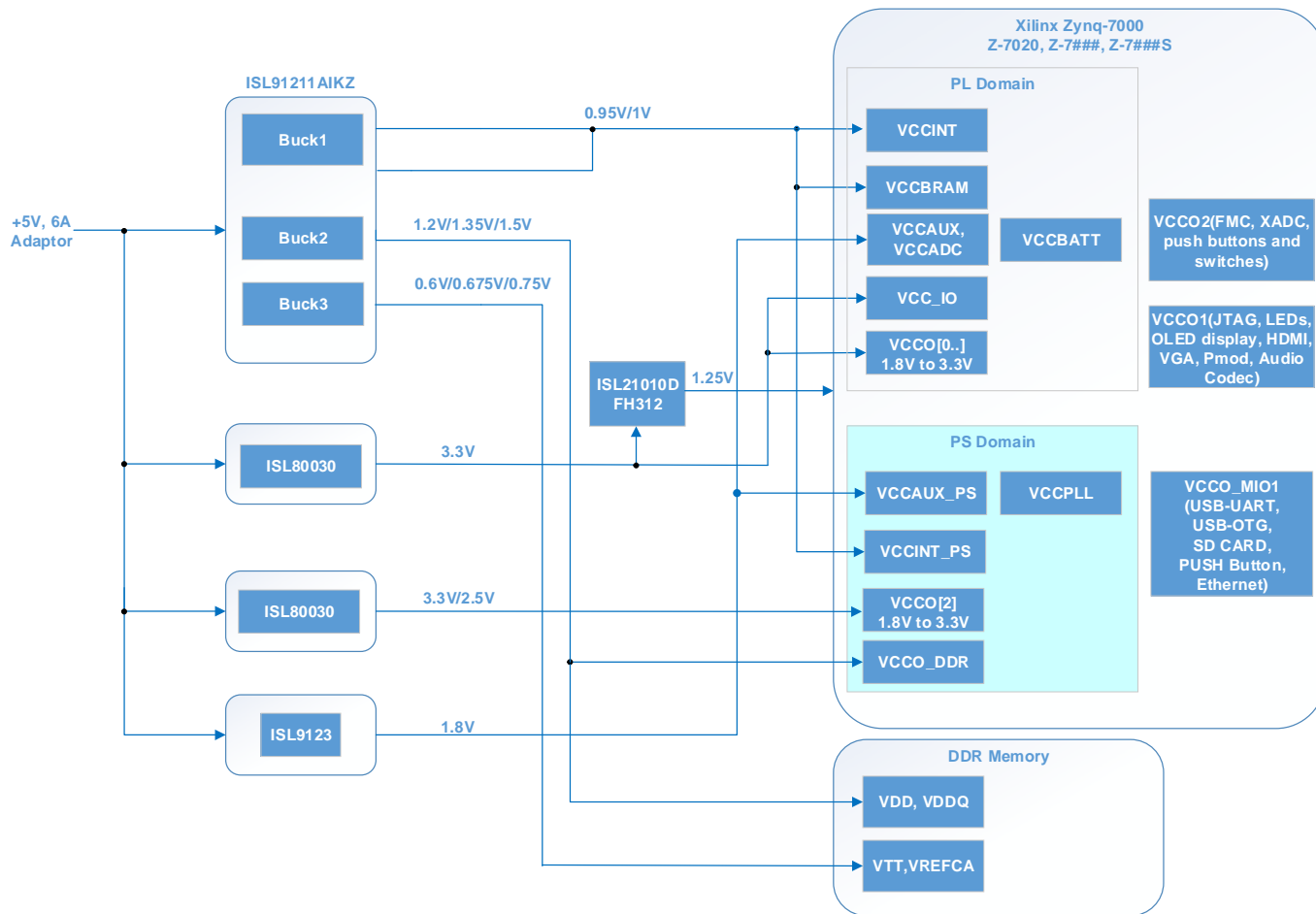

Figure 6. Zynq-7000 FPGA Block Diagram

Table 6. ISL91211AIKZ-TR5874 and ISL91211AIKZ-TR5873 DVS Output Option for Zynq-7000 Power Rail

Zynq-7000	ISL91211AIK (2+1+1)	ISL91211AIKZ-TR5874 (I <sup>2</sup> C Slave Address = 0x60)			
	DVS_PIN1/DVS_PIN0	00	01	10	11
VCCINT VCCBRAM	VOUT1	1.0V	0.95V	0.95V	0.95V
VDDQ	VOUT2	1.2V	1.2V	1.35V	1.5V
VTT	VOUT3	0.6V	0.6V	0.675V	0.75V

Zynq-7000	ISL91211AIK (2+1+1)	ISL91211AIKZ-TR5873 (I <sup>2</sup> C Slave Address = 0x60)	
	DVS_PIN1/DVS_PIN0	10	11
VCCINT VCCBRAM	VOUT1	1.0V	1.0V
VDDQ	VOUT2	1.35V	1.5V
VTT	VOUT3	0.675V	0.75V

### 1.3.5 PowerNavigator™ Software

The Renesas PowerNavigator software allows simple configuration and monitoring of multiple PMICs using a PC with a USB interface. PowerNavigator makes it easy to change all features and functions of your digital power supply design using a simple graphical user interface.

When the project file is complete, the Renesas USB to PMBus adapter dongle, ISLUSBEVAL1Z version V3.2, can be used to connect to the hardware. To connect to the PMBus interface of the controller, only I<sup>2</sup>C\_CLK, I<sup>2</sup>C\_SDA, and GND connections from the adapter to the board are required.

## 1.4 Recommended Products

### 1.4.1 ISL91211AIKZ and ISL91211BIKZ

The ISL91211AIK is a 4-phase, three output programmable Power Management IC (PMIC) and the ISL91211BIK is a 4-phase, four output programmable PMIC. They are optimized with highly efficient synchronous buck converters capable of multiphase and single-phase operations that can deliver up to 5A per phase continuous output current. Both devices feature four buck controllers and can reconfigure their power stages to these controllers. This flexibility allows seamless design-in for a wide range of applications in which high output power and small solution size are needed. The ISL91211AIK and ISL91211BIK integrate low ON-resistance MOSFETs and programmable PWM frequency, which allows the use of very small external inductors and capacitors. They feature automatic Diode emulation and Pulse Skipping modes under light-load conditions to improve efficiency and maximize battery life. The ISL91211AIK and ISL91211BIK deliver a highly robust power solution by featuring a controller based on the Renesas proprietary R5 technology, which provides tight output accuracy and load regulation, ultra-fast transient response, seamless DCM/CCM transitions, and requires no external compensation.

In addition to the standard interrupt, chip enable, and watchdog reset functions, the ISL91211AIK and ISL91211BIK also feature four MPIOs and three GPIOs that support SPI, I<sup>2</sup>C communication protocol, and various other pin mode functions.

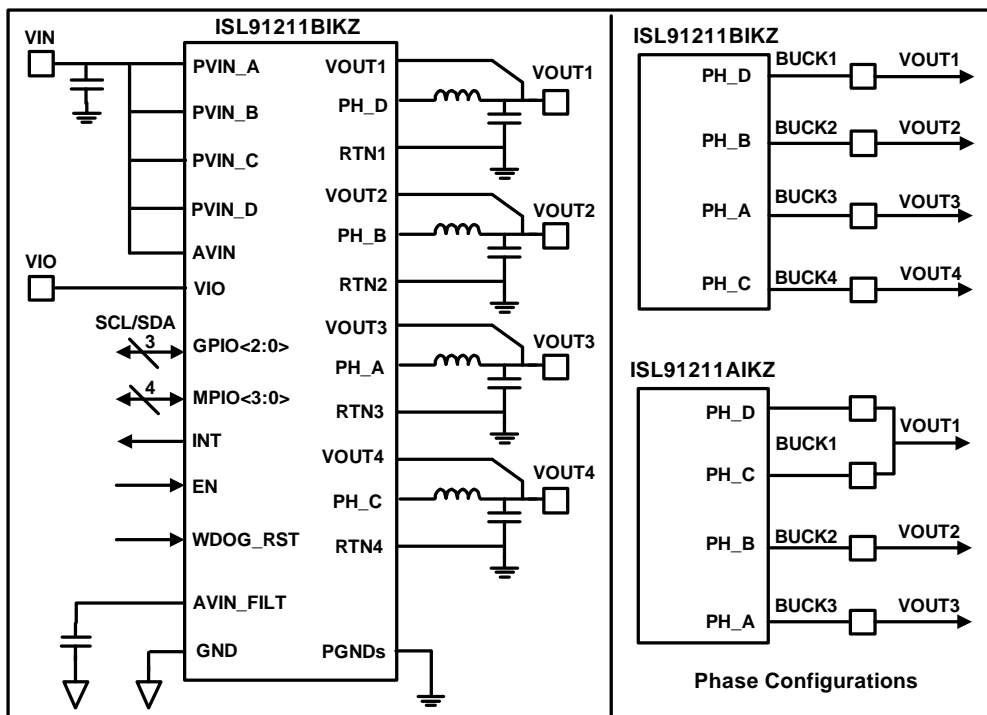

Figure 7. ISL91211BIKZ Simplified Application Circuit

The ISL91211AIK and ISL91211BIK have four independently programmable voltage settings for each buck controller that can set the output voltage. The four voltage settings are DVS0, DVS1, DVS2, and DVS3. By changing the DVS number selected, the corresponding output voltage is selected. Each output voltage is set by writing a 10-bit word to DVS Configuration 1 (BUCKx\_DVS0CFG1 register) and DVS Configuration 0 (BUCKx\_DVS0CFG0 register) in each buck. Configuration 1 holds the most significant eight bits and Configuration 0 holds the last two bits of the 10-bit word. The output voltage does not change until the LSB register is written.

When the master chip Enable pin (EN) is brought above 1.35[V], the ISL91211AIK and ISL91211BIK power up their key biasing circuits, load the OTP configuration registers, and start the power-up sequence.

**1.4.1.1 Buck Start-Up from Master Chip Enable Pin (EN)**

The Xilinx FPGA solution requires a different power-up sequence for each power rail to avoid the inrush current. The ISL91211AIK and ISL91211BIK supports programmable start-up and power-down delay times between the Master phases. The start-up and power-down sequence is initiated by EN pin with the internal BOOT time. The start-up and power-down delay times between the master phases are programmable from 0ms to 63ms. The soft-start rate from 1.25mV/μs to 50mV/μs are programmable. The controlled soft-start rate and buck regulator current limit limits the input inrush current to the output capacitor.

This is the example for the start-up sequence

- Run a prescribed start-up sequence for the buck outputs as soon as the internal BOOT signal is ready.
- An internal 1.4ms boot-up delay occurs from when EN is logic high to the time Buck1 starts powering up.
- Buck2, Buck3, and Buck4 then sequentially turn on with a 1ms delay in between. Each channel powers up at a slew rate of 3mV/μs.

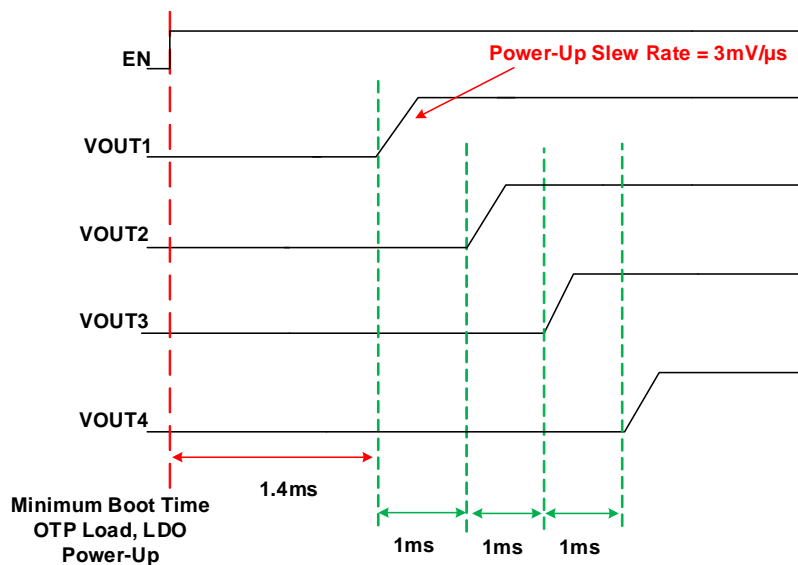
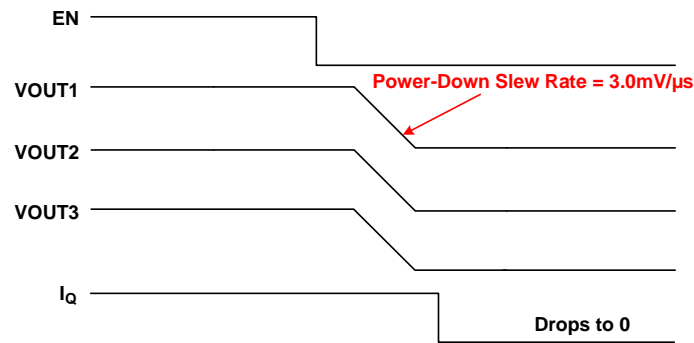

Figure 8. Chip Enable Power-Up Example

**1.4.1.2 Buck Power-Down from Master Chip Enable Pin (EN)**

When the master chip Enable pin (EN) is brought below the falling threshold of the comparator of 0.4V, all the bucks are ramped down at 3mV/μs at the same time. The bias circuits then power down, forcing the chip into shutdown. This slew rate is controlled until the output voltage is ~250mV, at which point the ISL91211AIK and ISL91211BIK engage a weak resistive pull-down that can discharge  $V_{OUT}$  to 0V.



**Figure 9. Chip Power-Down Example**

**1.4.2 ISL80030**

The ISL80030 is a highly efficient, monolithic, synchronous step-down DC/DC converter that can deliver up to 3A of continuous output current from a 2.7V to 5.5V input supply. The ISL80030 uses peak current mode control architecture to allow very low duty cycle operation. These devices operate at a 1MHz switching frequency, thereby providing superior transient response and allowing for the use of small inductors. The ISL80030 also has excellent stability. The ISL80030 integrates very low  $r_{DS(ON)}$  MOSFETs to maximize efficiency. In addition, because the high-side MOSFET is a PMOS, the need for a Boot capacitor is eliminated, thereby reducing external component count. The devices can operate at 100% duty cycle.

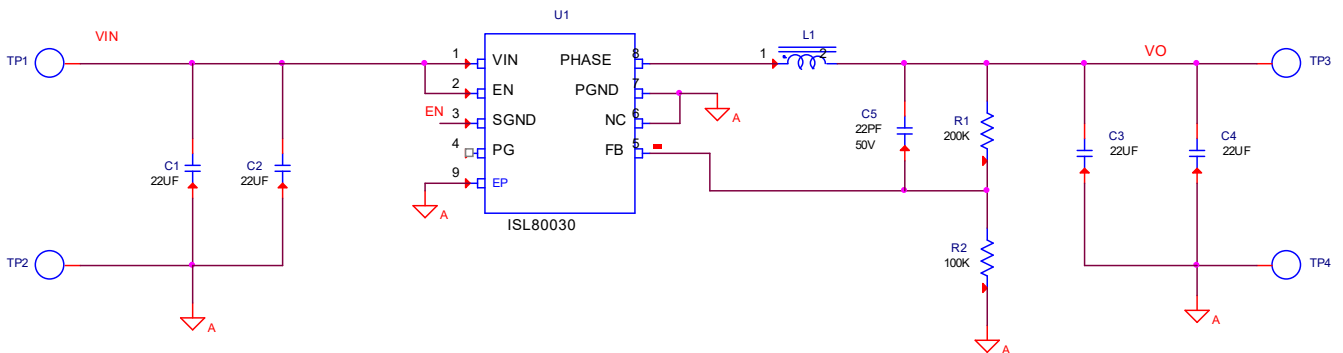

**Figure 10. ISL80030 Simplified Application Circuit for VCCIO\_1V8**

The ISL80030 employs the current-mode Pulse-Width Modulation (PWM) control scheme for fast transient response and pulse-by-pulse current limiting. The current loop consists of the oscillator, PWM comparator, current sensing circuit, and the slope compensation for current loop stability. The slope compensation is 900mV/Ts, which changes with frequency. The gain for the current sensing circuit is typically 250mV/A. The control reference for the current loop comes from the Error Amplifier's (EAMP) output for fast transient. The reference voltage is 0.6V, which is used by feedback to adjust the output of the error amplifier. The error amplifier is a transconductance amplifier that converts the voltage error signal to a current output. The voltage loop is internally compensated with the 27pF and 200kΩ RC network. The maximum EAMP voltage output is precisely clamped to 1.6V.

### 1.4.3 ISL9123

The ISL9123 is a highly integrated buck switching regulator that is capable of supplying output voltage down to 0.4V. It features an extremely low quiescent current consumption of 940nA in Regulation mode, 170nA in Forced Bypass mode, and 9nA in Shutdown mode. It provides 80% efficiency at 10 $\mu$ A load and has a peak efficiency of 97%. It supports input voltages from 1.8V to 5.5V. The ISL9123 has automatic bypass functionality for situations in which the input voltage is close to the output voltage. In addition to the automatic bypass functionality, the Forced Bypass power saving mode can be chosen if voltage regulation is not required. Forced Bypass power saving mode is accessible using the I<sup>2</sup>C interface bus. The ISL9123 is capable of delivering up to 600mA of output current ( $V_{IN} = 3.6V$ ,  $V_{OUT} = 1.8V$ ) and provides excellent efficiency due to its adaptive frequency hysteretic control architecture. The ISL9123 is designed for stand-alone applications and supports a default output voltage at Power-On Reset (POR). After POR, the output voltage can be adjusted in the range of 0.4V to 5.375V by using the I<sup>2</sup>C interface bus. Specific default output voltages are available upon request.

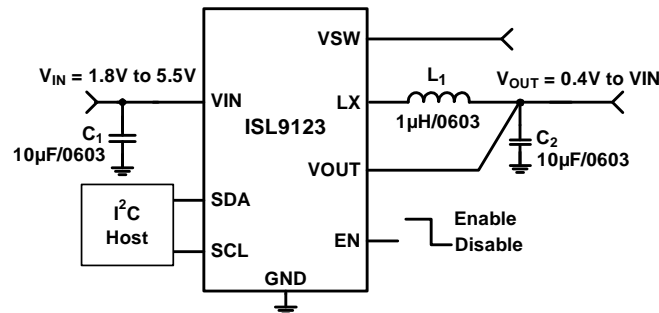

Figure 11. ISL9123 Simplified Application Circuit

### 1.4.4 ISL21010DFH312

The ISL21010 is a precision, low dropout micro-power bandgap voltage reference in a space-saving SOT-23 package. It operates from a single 2.2V to 5.5V supply (minimum voltage is dependent on voltage option) and provides a  $\pm 0.2\%$  accurate reference. The ISL21010 provides up to 25mA output current sourcing with low 150mV dropout voltage. Output voltage options include 1.024V, 1.25V, 1.5V, 2.048V, 2.5V, 3.0V, 3.3V, and 4.096V. The low supply current and low dropout voltage combined with high accuracy make the ISL21010 ideal for precision XADC input reference on the Xilinx 7 series FPGA's. The XADC includes a 12-bit, 1M sample per second (MSPS) ADC and on-chip sensors.

## 2. Test Results

### 2.1 Testing and Results

#### 2.1.1 VCCINT/VCCBRAM Power Rail Test – ISL91211AIK

Test condition: PVIN = 5.0V, VCCINT/VCCBRAM = 0.95V, L = 220nH, f<sub>SW</sub> = 2MHz, 2PH Configuration

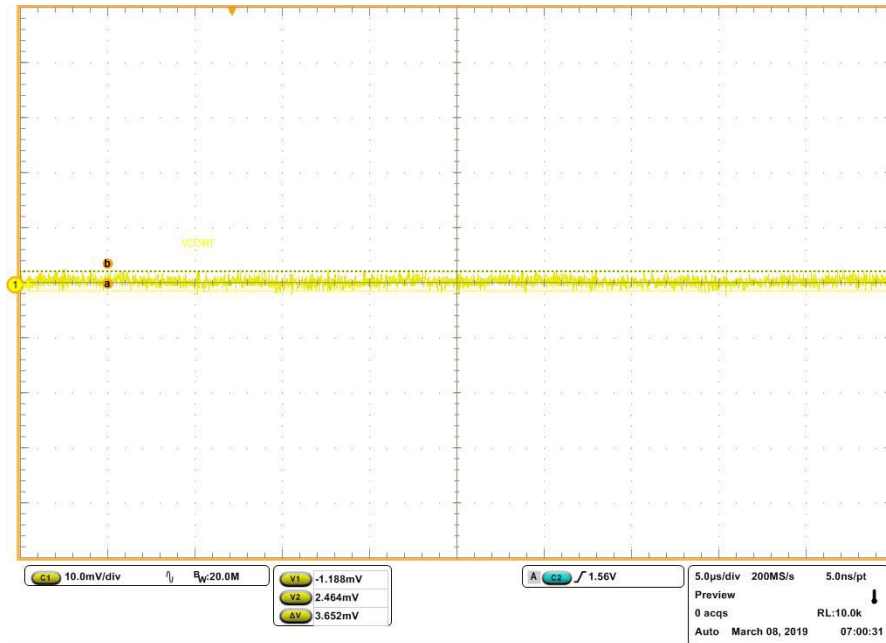

Figure 12. VCCINT Output Ripple at No Load, <5mV<sub>p-p</sub>

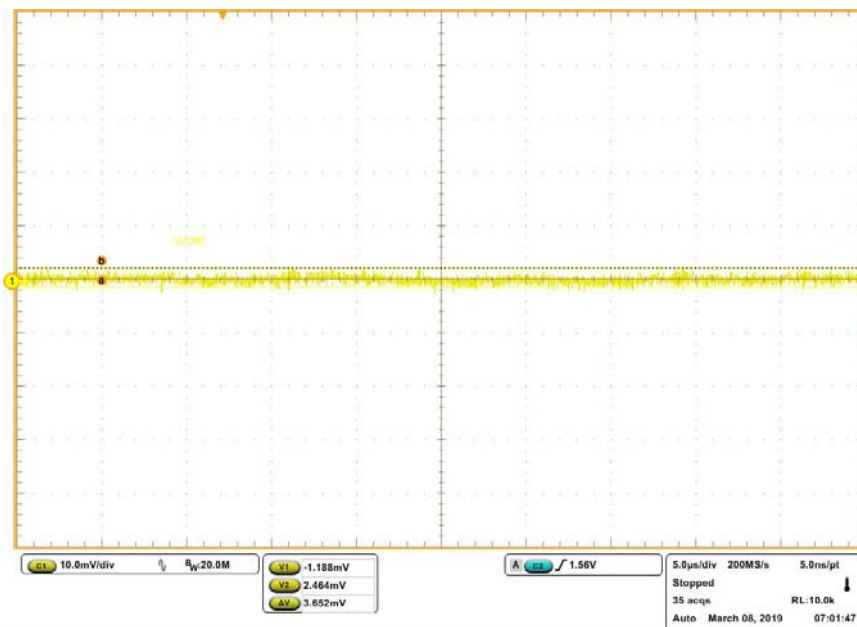

Figure 13. VCCINT Output Ripple at 6A Load, <5mV<sub>p-p</sub>

Test condition: PVIN = 5.0V, VCCINT/VCCBRAM = 0.95V, L = 220nH, f<sub>SW</sub> = 2MHz, 2PH Configuration (Continued)

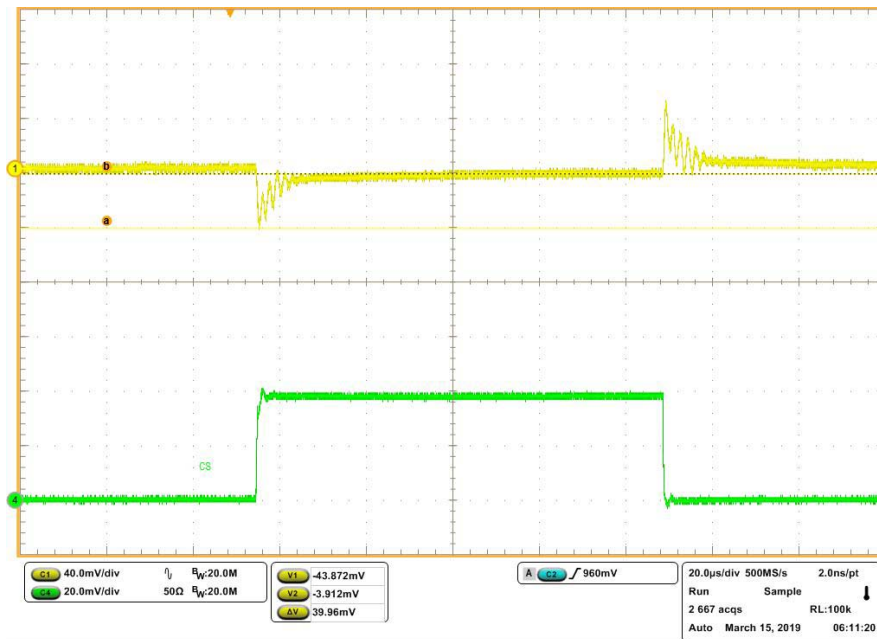

Figure 14. VCCINT Load Transient, 100mA to 4A, Undershoot: 39.96mV

### 2.1.2 VMGTAVCC Power Rail Test – ISL91211AIK

Test condition: PVIN = 5.0V, VMGTAVCC = 1.0V, L = 470nH, f<sub>SW</sub> = 2MHz, 1PH Configuration

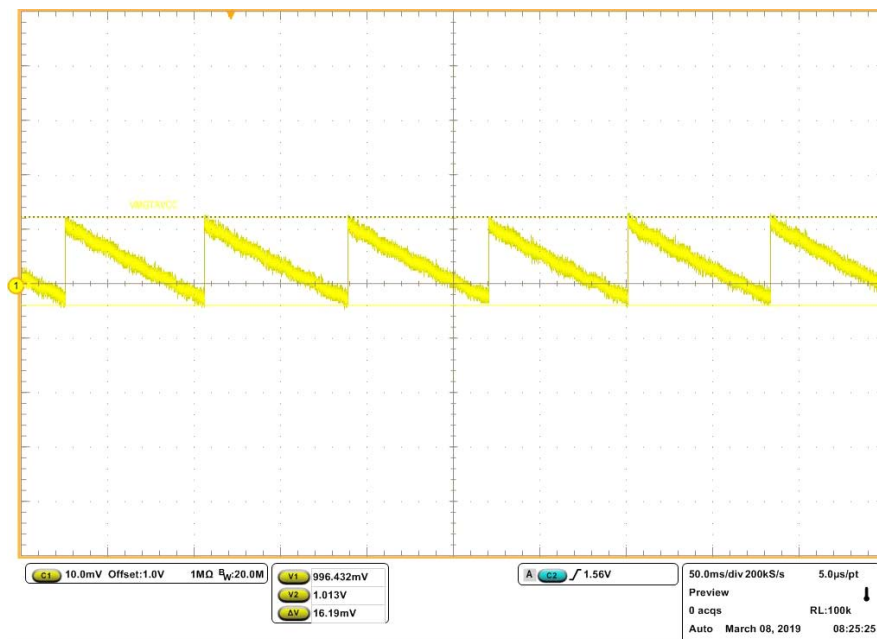

Figure 15. VMGTAVCC Output Ripple at No load, <16.19mV<sub>P,P</sub>

Test condition: PVIN = 5.0V, VMGTAVCC = 1.0V, L = 470nH, f<sub>SW</sub> = 2MHz, 1PH Configuration (Continued)

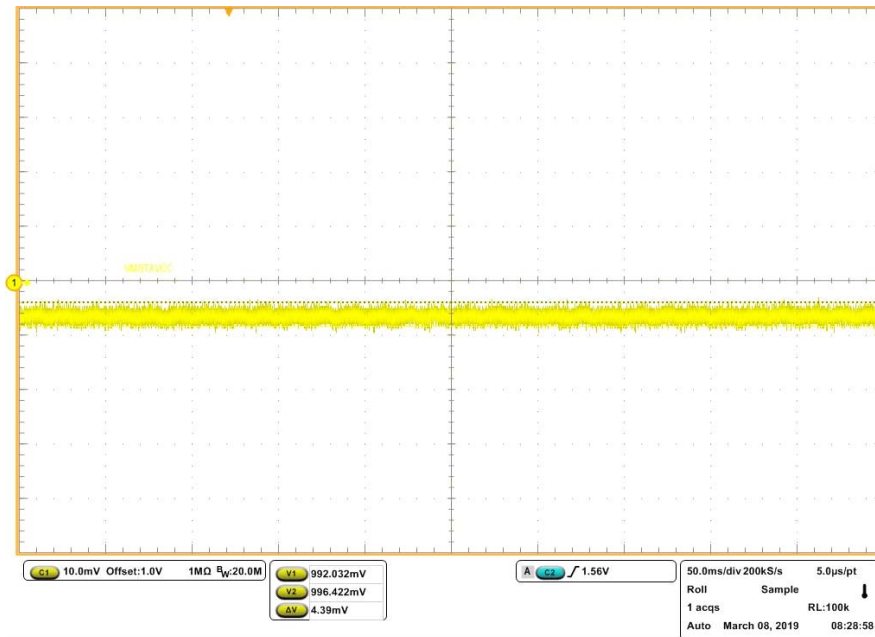

Figure 16. VMGTAVCC Output Ripple at 1A, <5mV<sub>p-p</sub>

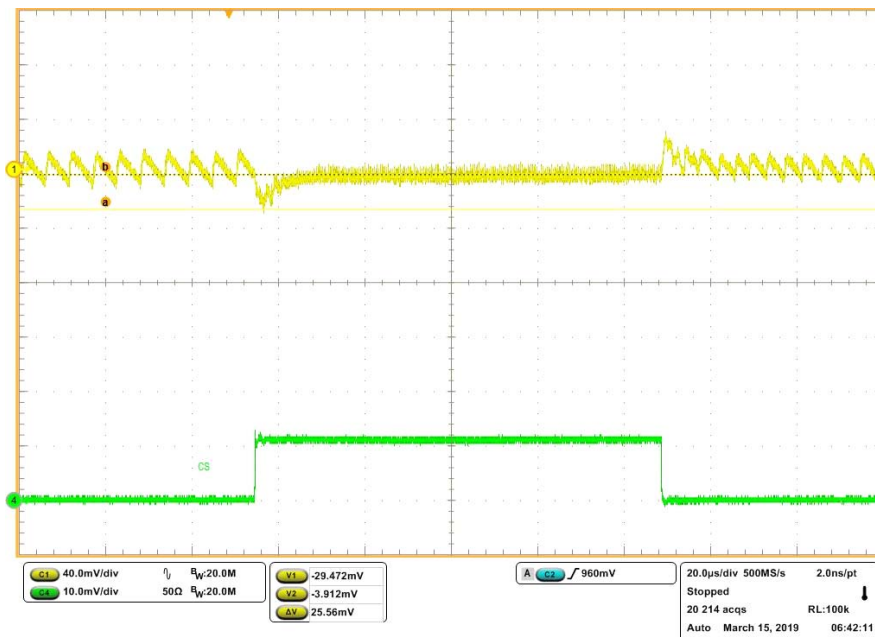

Figure 17. VMGTAVCC Load Transient, 100mA to 1A, Undershoot: 25.56mV

### 2.1.3 VMGTAVTT Power Rail Test - ISL91211AIK

Test condition: PVIN = 5.0V, VMGTAVTT = 1.2V, L = 470nH, f<sub>SW</sub> = 2MHz, 1PH Configuration

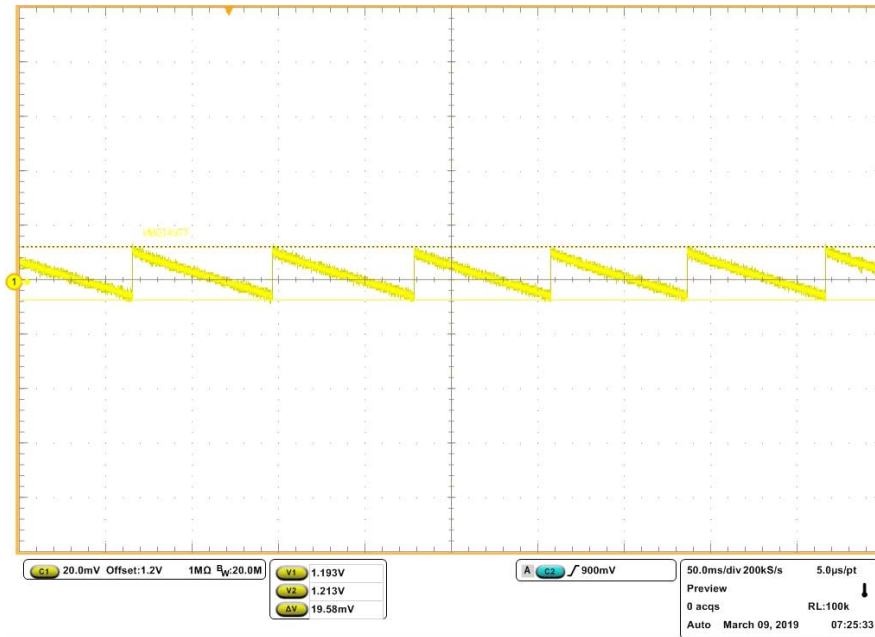

Figure 18. VMGTAVTT Output Ripple at No Load, <19.58mV<sub>P-P</sub>

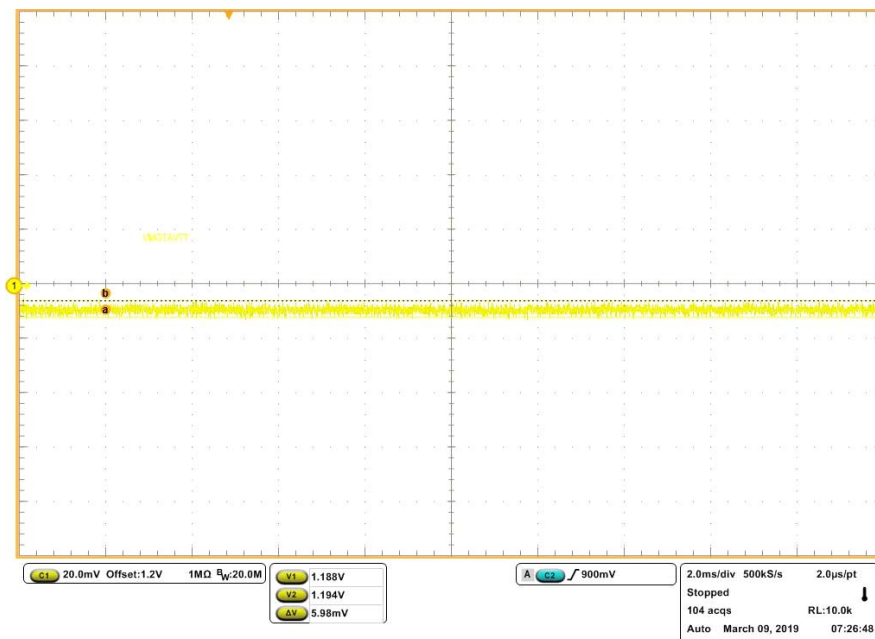

Figure 19. VMGTAVTT Output Ripple at 1A Load, <6mV<sub>P-P</sub>

Test condition: PVIN = 5.0V, VMGTAVTT = 1.2V, L = 470nH, f<sub>SW</sub> = 2MHz, 1PH Configuration (Continued)

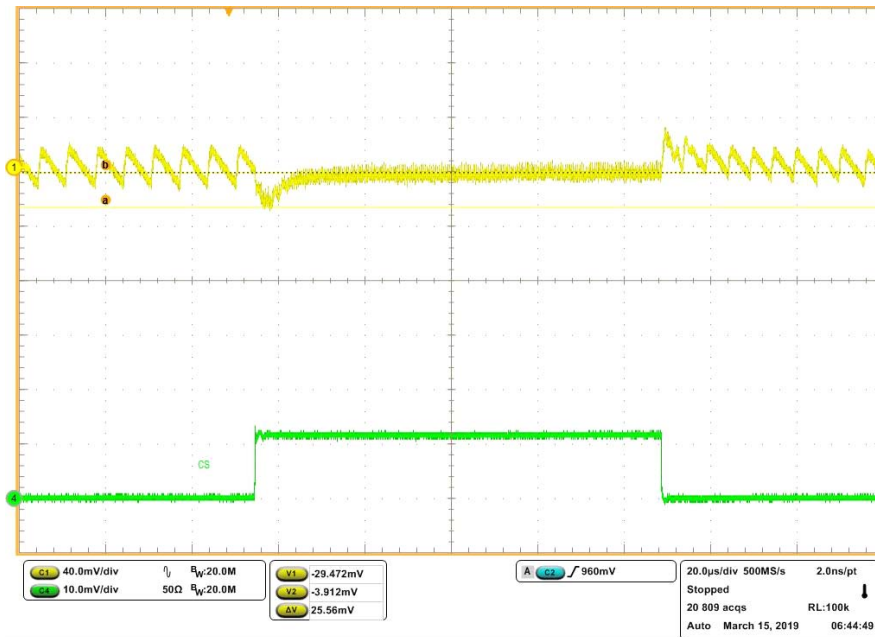

Figure 20. VMGTAVTT Load Transient, 100mA to 1A, Undershoot: 25.56mV

### 2.1.4 VCCDDR Power Rail Test - ISL91211BIK

Test condition: PVIN = 5.0V, VCCDDR = 1.35V, L = 220nH, f<sub>SW</sub> = 2MHz, 1PH

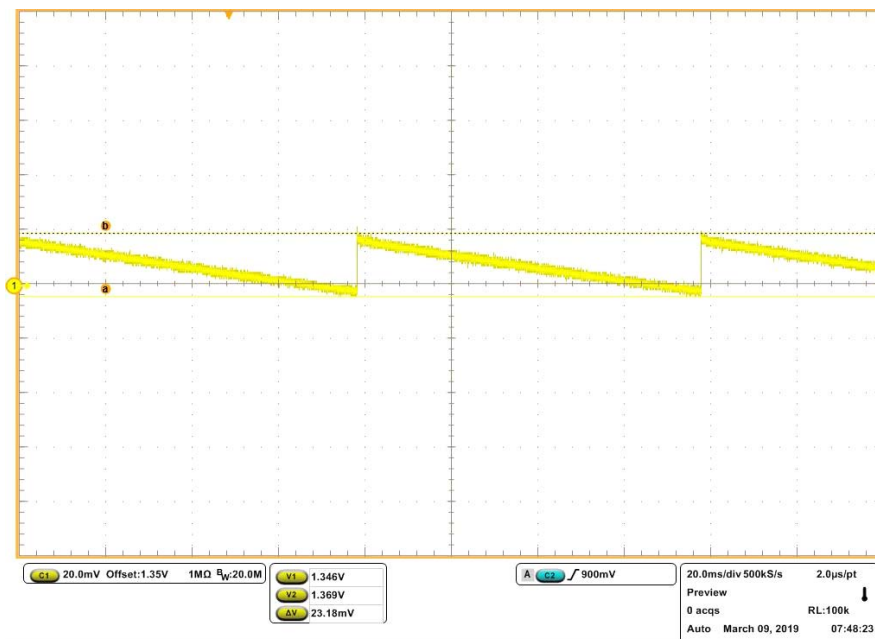

Figure 21. VCCDDR Output Ripple at No Load, <23.18mV<sub>P-P</sub>

Test condition: PVIN = 5.0V, VCCDDR = 1.35V, L = 220nH, f<sub>SW</sub> = 2MHz, 1PH (Continued)

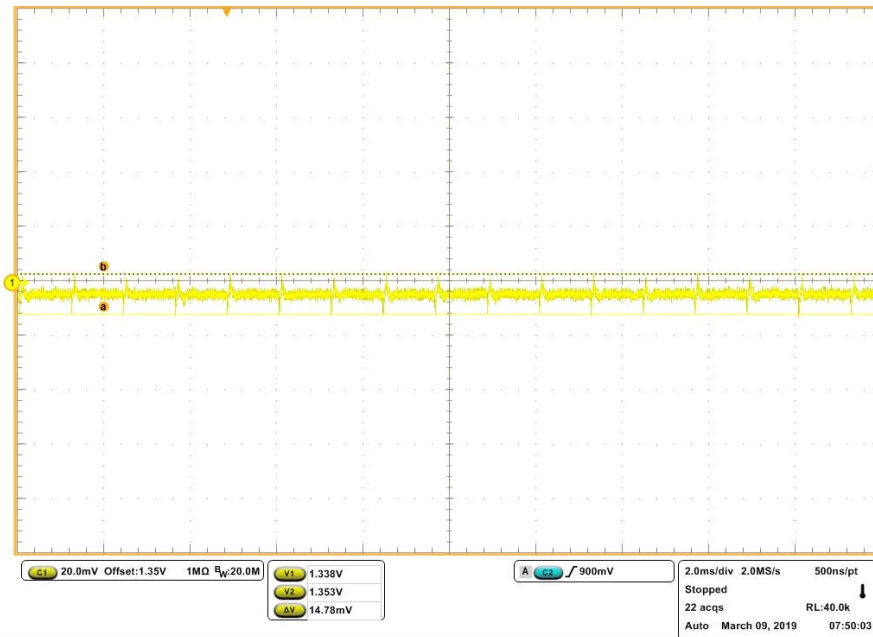

Figure 22. VCCDDR Output Ripple at 2A Load, <14.78mV<sub>P-P</sub>

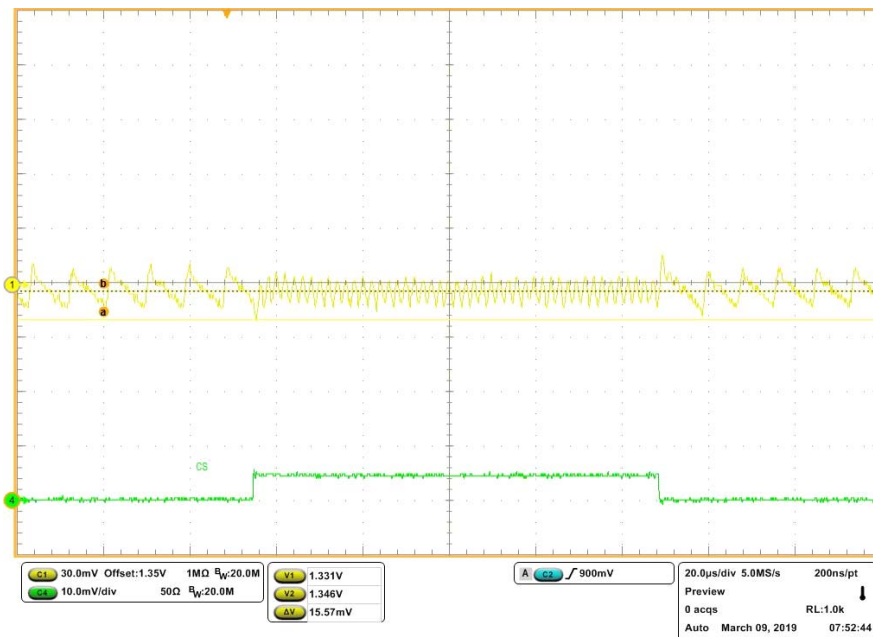

Figure 23. VCCDDR Load Transient, 100mA to 500mA, Undershoot: 15.57mV

### 2.1.5 VTT/VREFCA (VDDQ/2) Power Rail Test - ISL91211BIK

Test condition: PVIN = 5.0V, VTT = 0.75V, L = 470nH, f<sub>SW</sub> = 2MHz, FPWM mode, 1PH

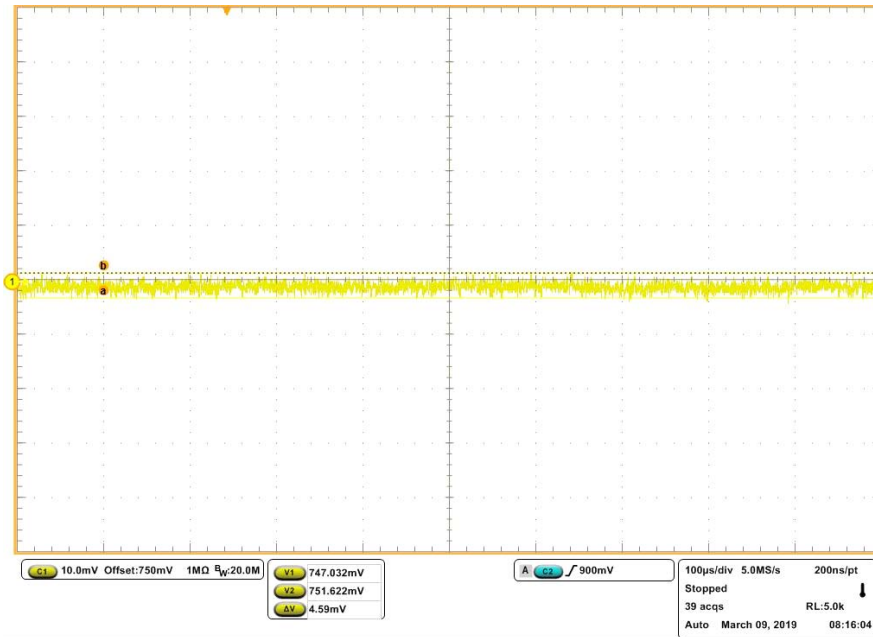

Figure 24. VTT Output Ripple at No Load, <5mV<sub>p-p</sub>

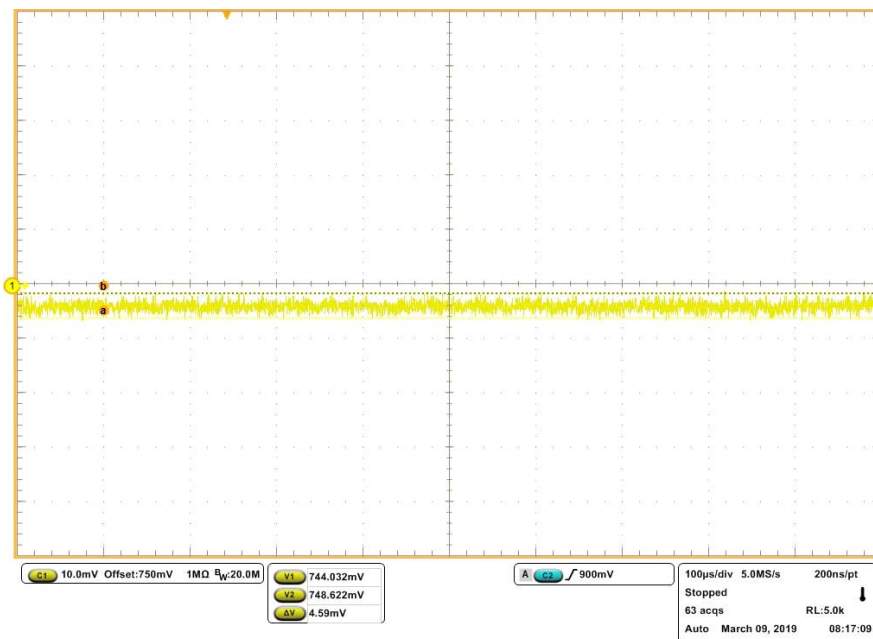

Figure 25. VTT Output Ripple at 2A, <5mV<sub>p-p</sub>

Test condition: PVIN = 5.0V, VTT = 0.75V, L = 470nH, f<sub>SW</sub> = 2MHz, FPWM mode, 1PH (Continued)

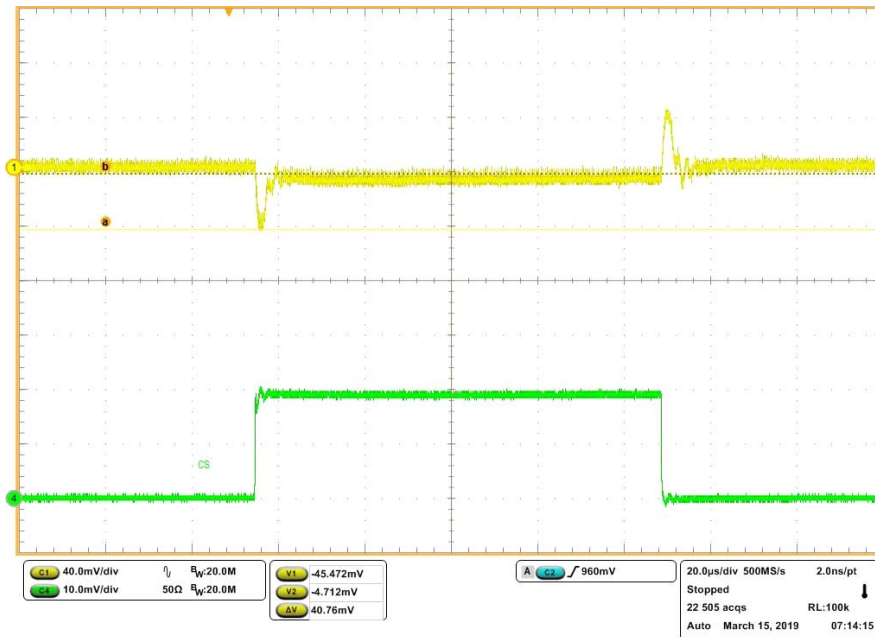

Figure 26. VTT Load Transient, FCCM Mode, 100mA to 2A, Undershoot: 40.76mV

### 2.1.6 VCCAUX/VCCADC Power Rail - ISL91211BIK

Test condition: PVIN = 5.0V, VCCAUX = 1.8V, L = 470nH, f<sub>SW</sub> = 2MHz, 1PH

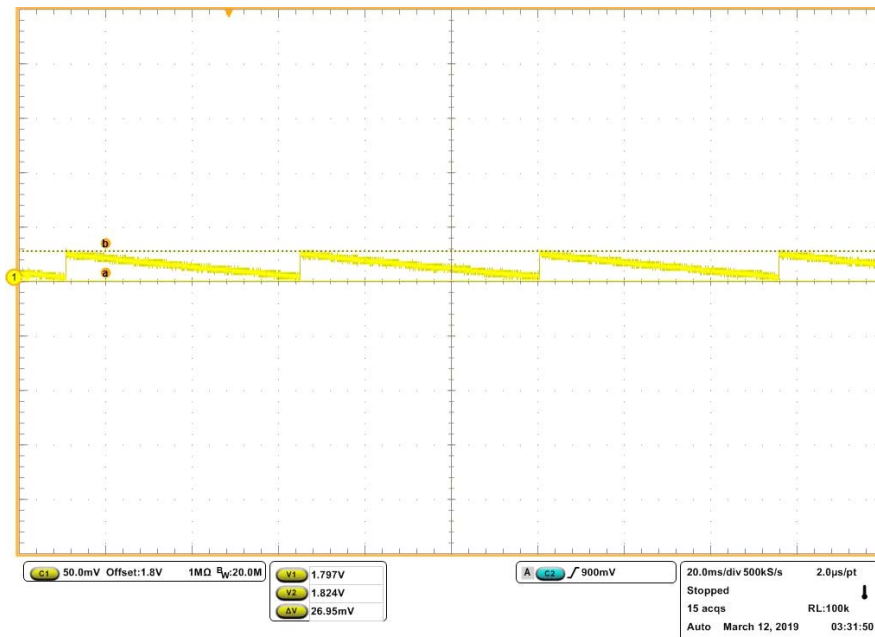

Figure 27. VCCAUX Output Ripple at No Load, <26.95mV<sub>P-P</sub>

Test condition: PVIN = 5.0V, VCCAUX = 1.8V, L = 470nH, f<sub>SW</sub> = 2MHz, 1PH (Continued)

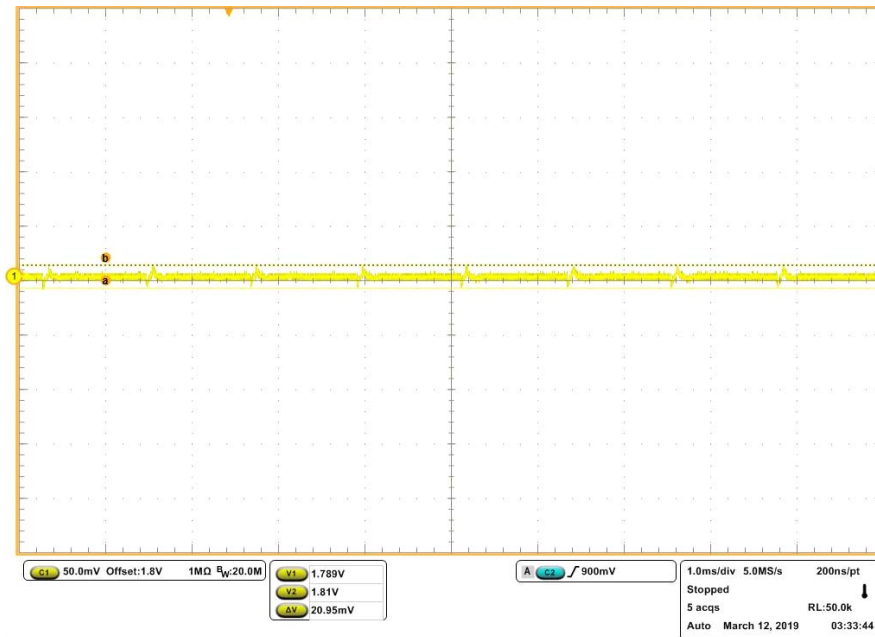

Figure 28. VCCAUX Output Ripple at 1A load, <21mV<sub>p-p</sub>

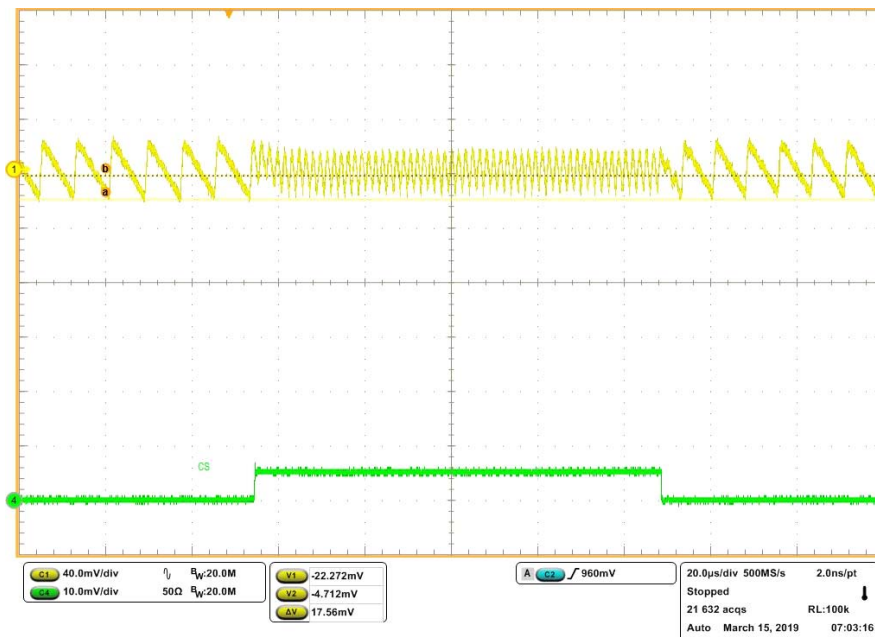

Figure 29. VCCAUX Load Transient, 100mA to 500mA, Undershoot: 17.56mV

## 2.1.7 VCCO Power Rail Test

### 2.1.7.1 VCCO 2.5V Power Rail - ISL80030

Test condition: PVIN = 5.0V, VCCO 2.5V = 2.5V, L = 2.2 $\mu$ H, f<sub>SW</sub> = 1MHz, 1PH

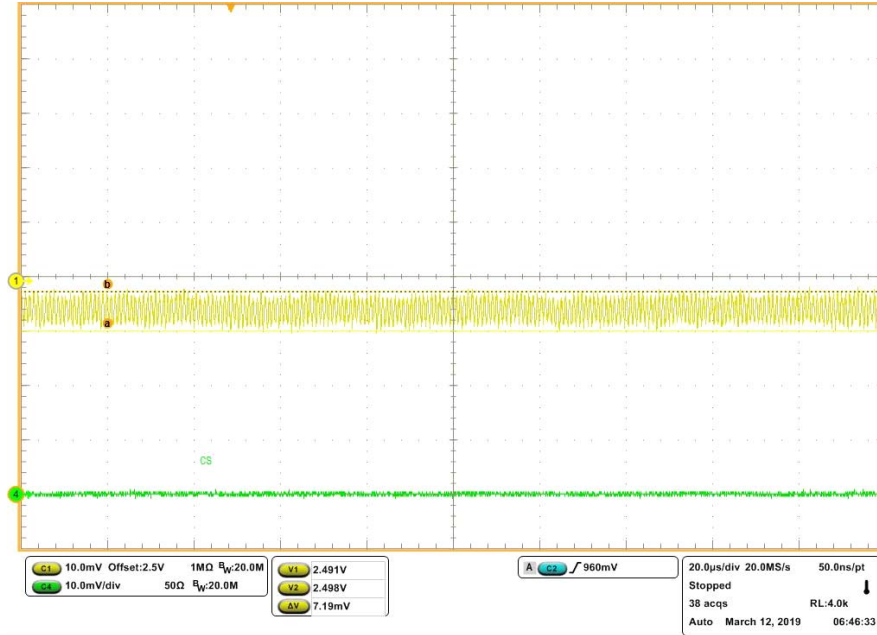

Figure 30. VCCO 2.5V Output Ripple at No Load, <7.19mV<sub>P-P</sub>

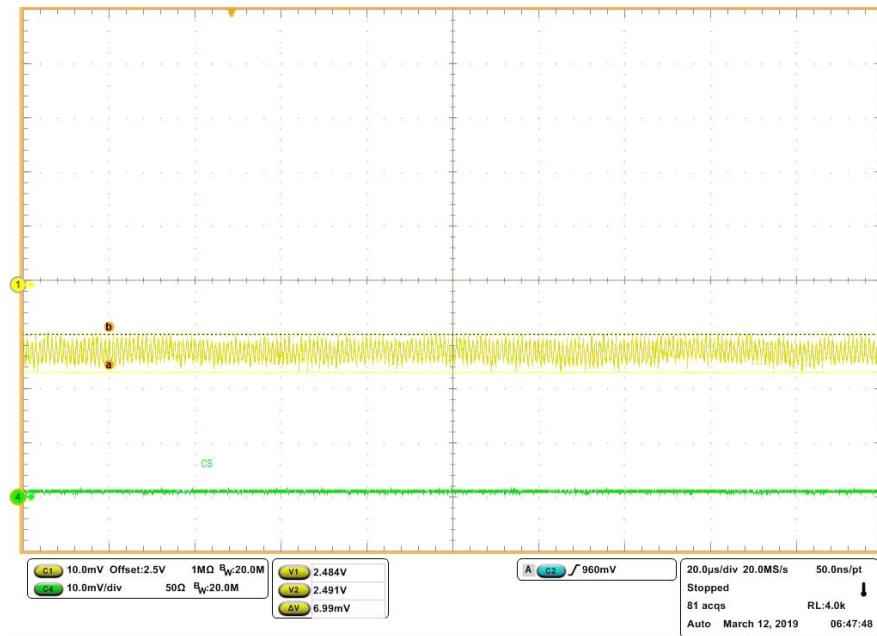

Figure 31. Output Ripple at No Load, <7.0mV<sub>P-P</sub>

Test condition: PVIN = 5.0V, VCCO 2.5V = 2.5V, L = 2.2μH, f<sub>SW</sub> = 1MHz, 1PH (Continued)

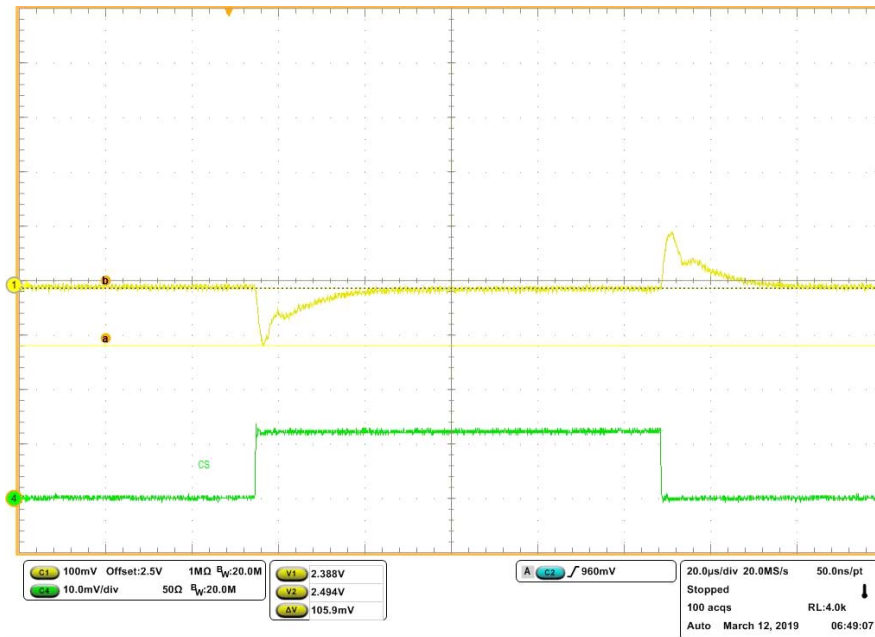

Figure 32. VCCO 2.5V Load Transient, 100mA to 1.5A, Undershoot: 105.9mV

### 2.1.7.2 VCCO 3.3V Power Rail - ISL80030

Test condition: PVIN = 5.0V, VCCO 3.3V = 3.3V, L = 2.2μH, f<sub>SW</sub> = 1MHz, 1PH

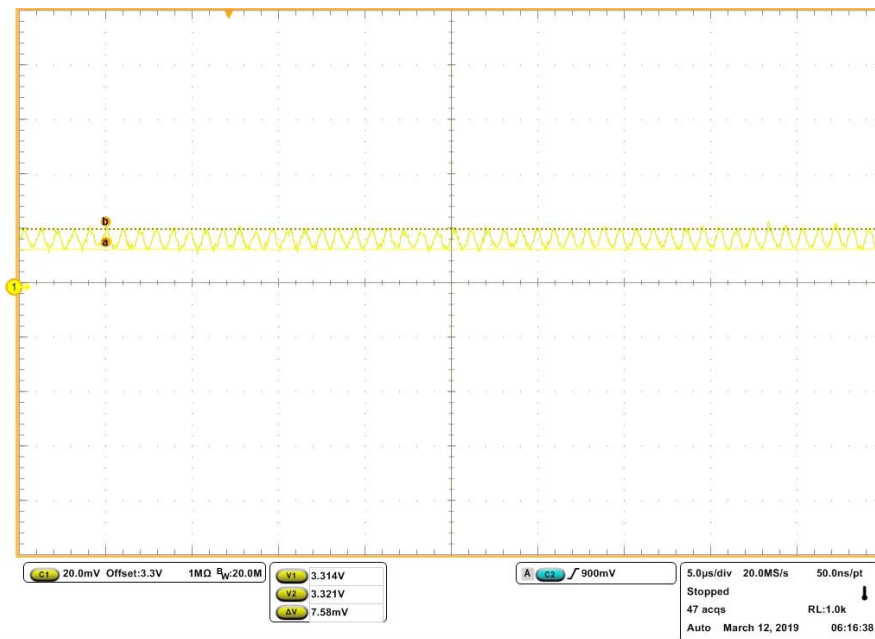

Figure 33. VCCO 3.3V Output Ripple at No Load, <7.58mV<sub>p-p</sub>

Test condition: PVIN = 5.0V, VCCO 3.3V = 3.3V, L = 2.2μH, f<sub>SW</sub> = 1MHz, 1PH (Continued)

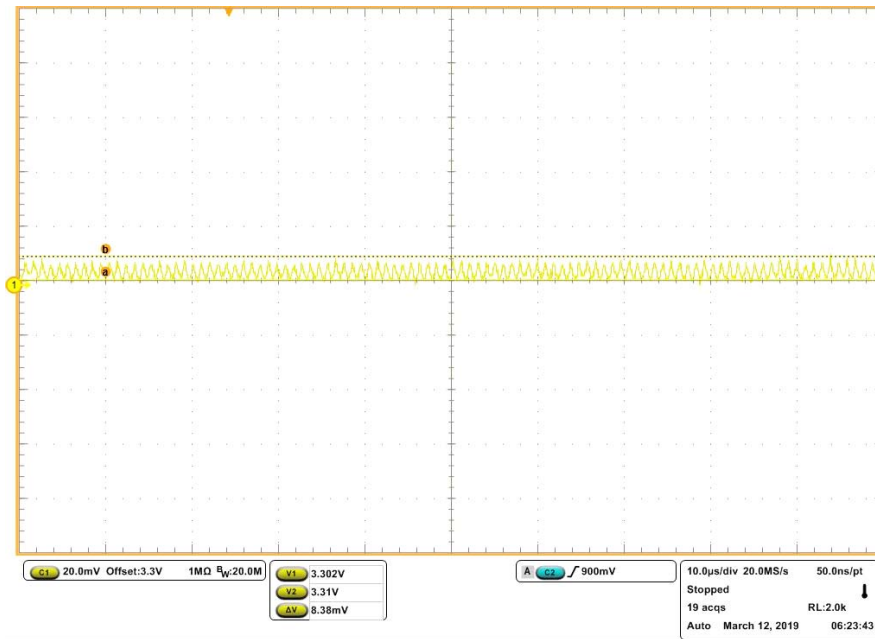

Figure 34. VCCO 3.3V Output Ripple at 3A, <8.3mV<sub>p-p</sub>

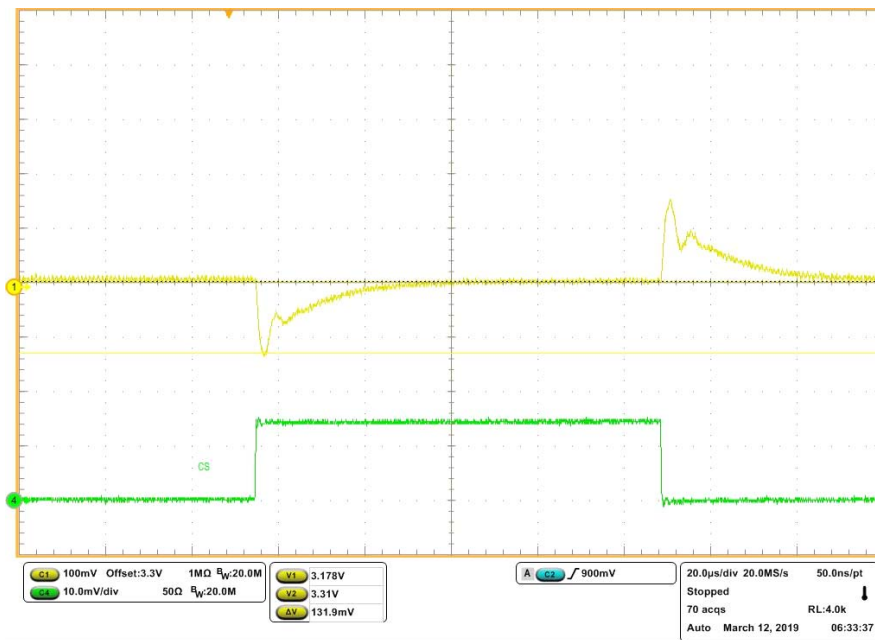

Figure 35. VCCO 3.3V Load Transient, 100mA to 1.5A, Undershoot: 131.9mV

### 2.1.8 XADC Power Rail Test - ISL21010DFH312

Test condition:  $V_{IN} = 3.3V$ , XADC = 1.25V

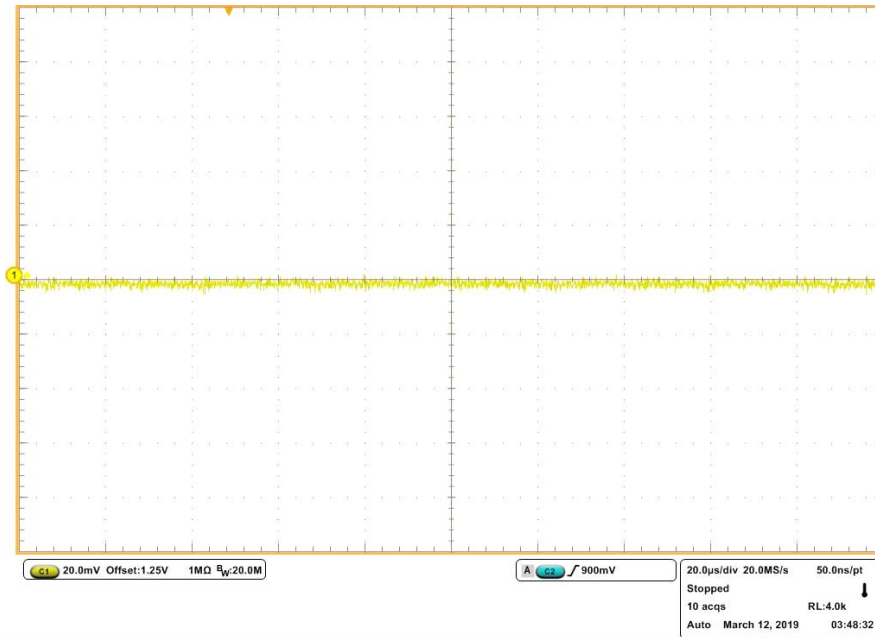

Figure 36. XADC Output Voltage Ripple, <math><2.5mV\_{P-P}</math>

### 3. Layout Guidelines

#### 3.1 Reference Boards

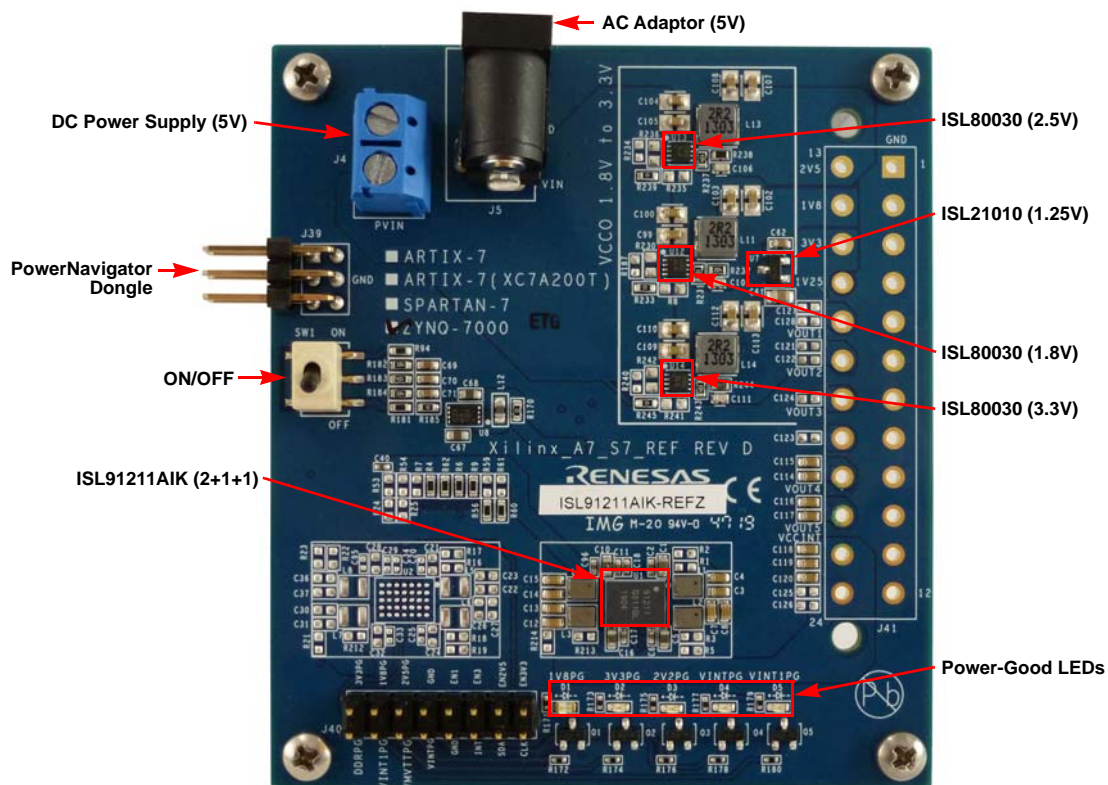

Figure 37. ISL91211AIK-REFZ Top

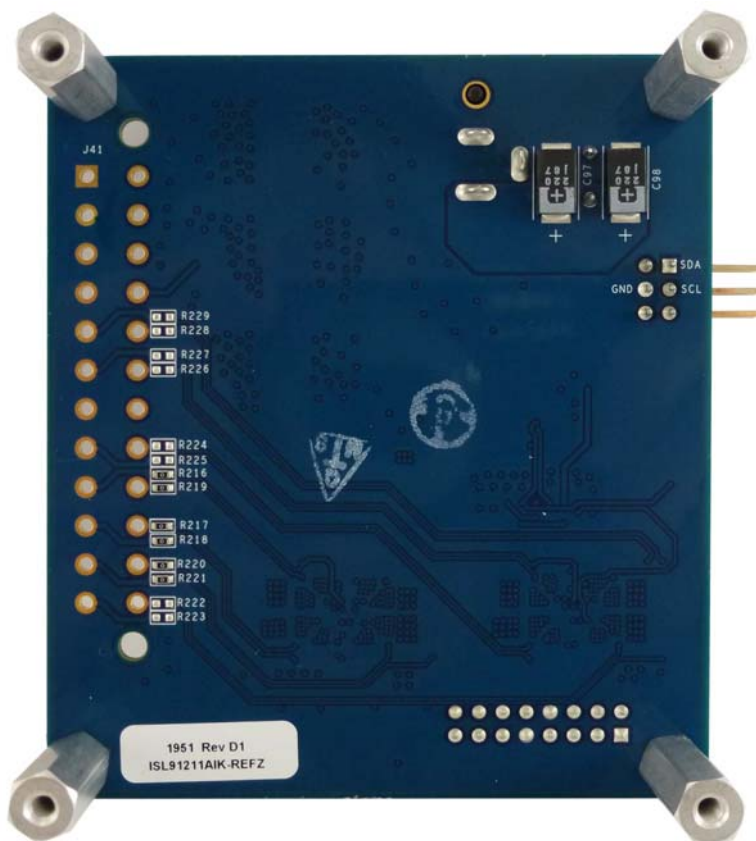

Figure 38. ISL91211AIK-REFZ Bottom

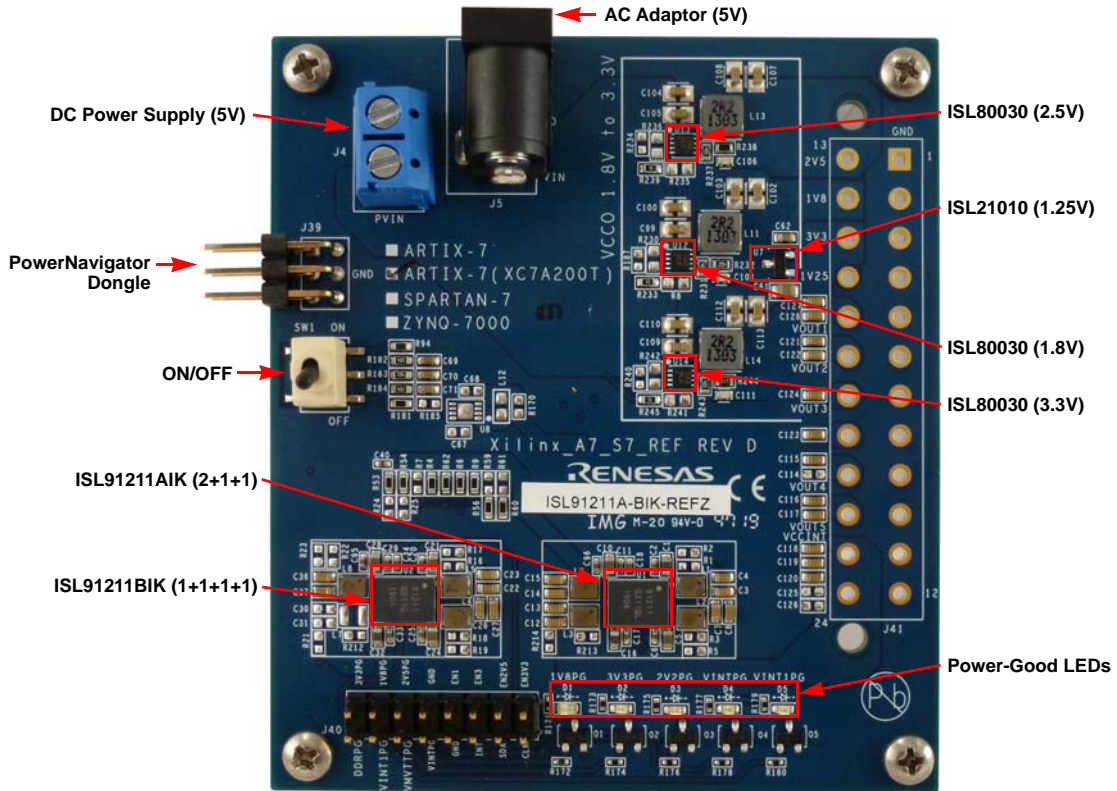

Figure 39. ISL91211A-BIK-REFZ Top

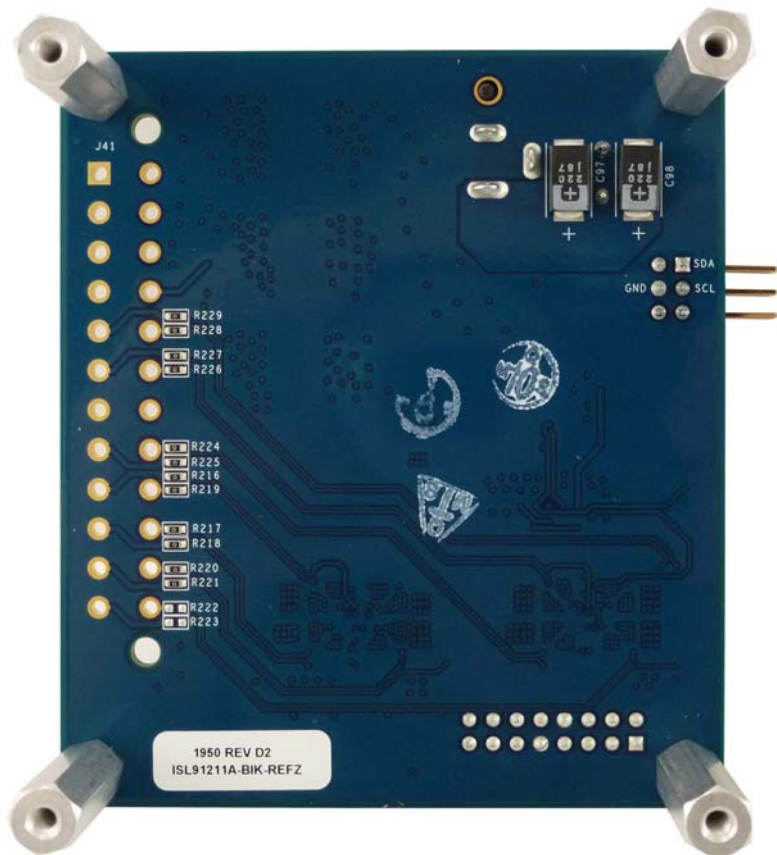

Figure 40. ISL91211A-BIK-REFZ Bottom

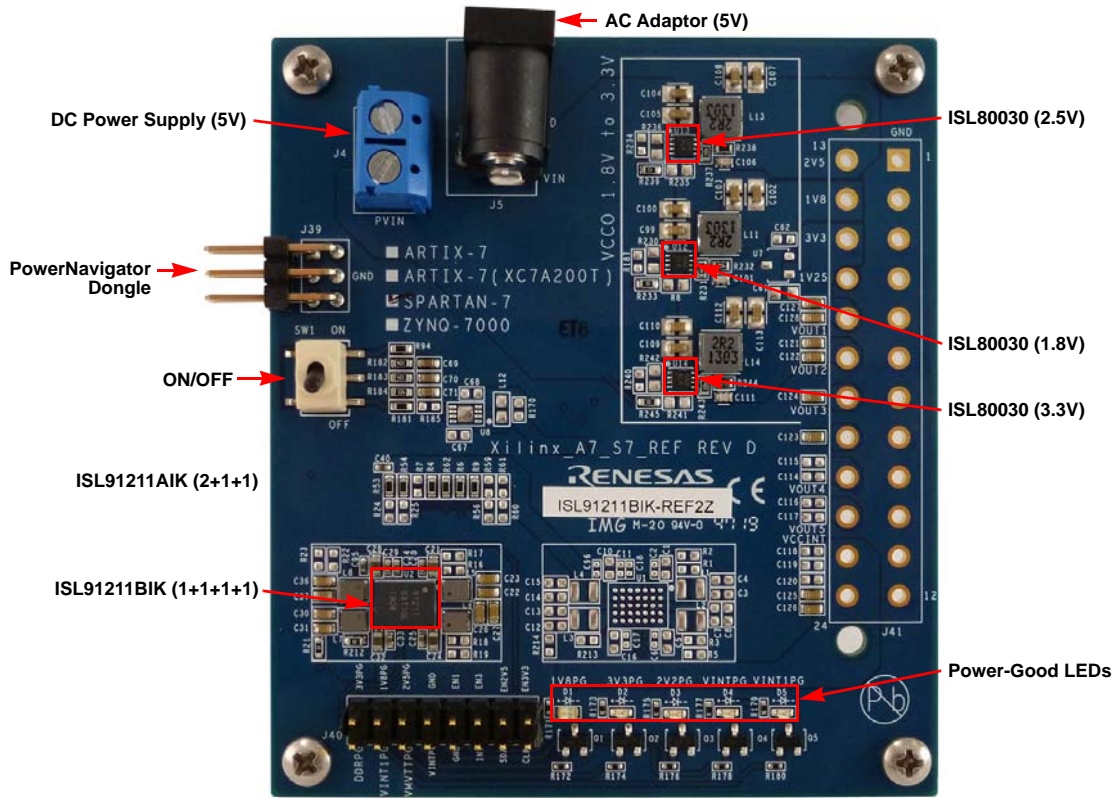

Figure 41. ISL91211BIK-REFZ Top



Figure 42. ISL91211BIK-REFZ Bottom

### 3.2

## Reference Board Schematics

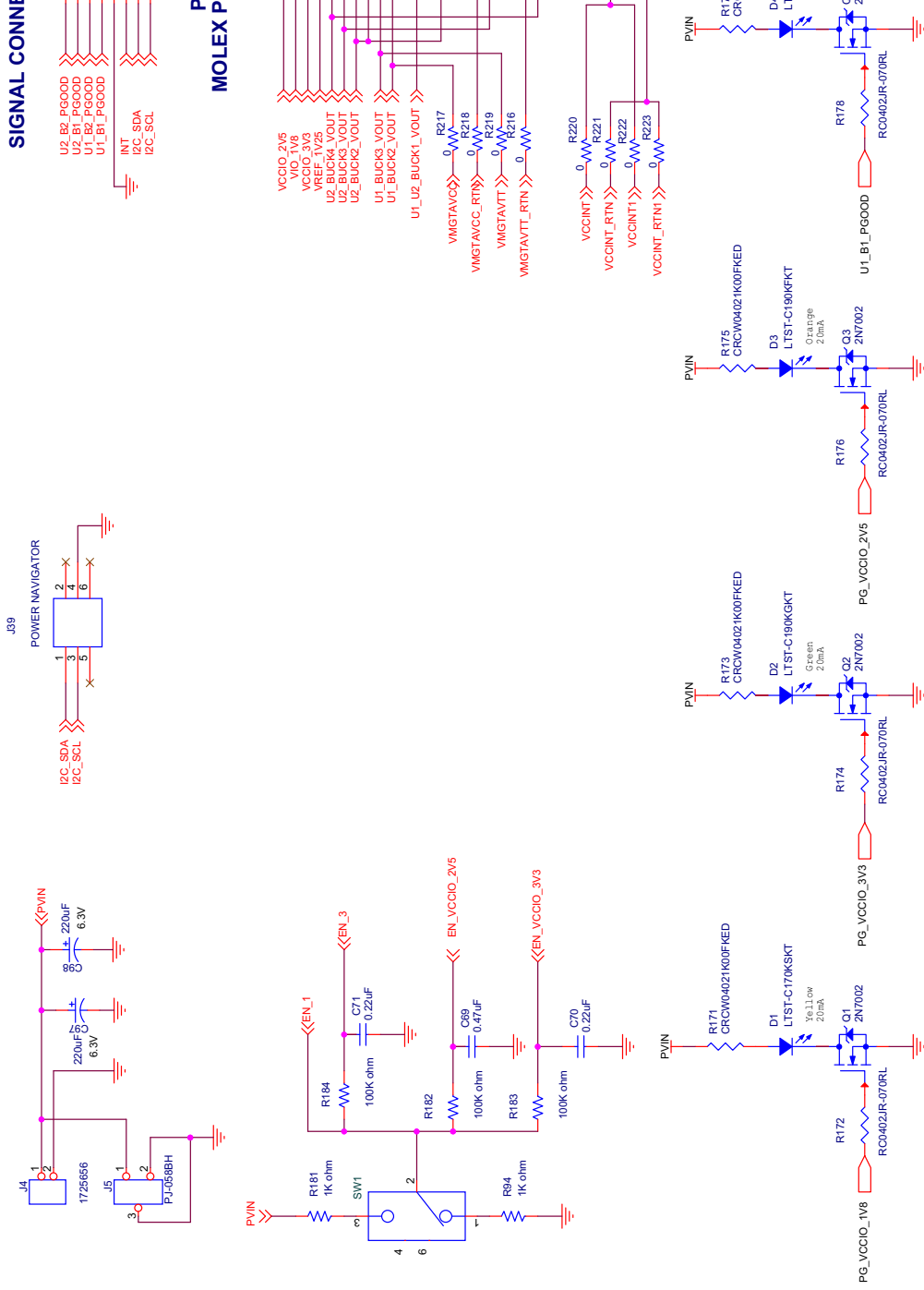

Figure 43. XILINX\_A7\_S7 Connectors and Power-Good LED Indicators

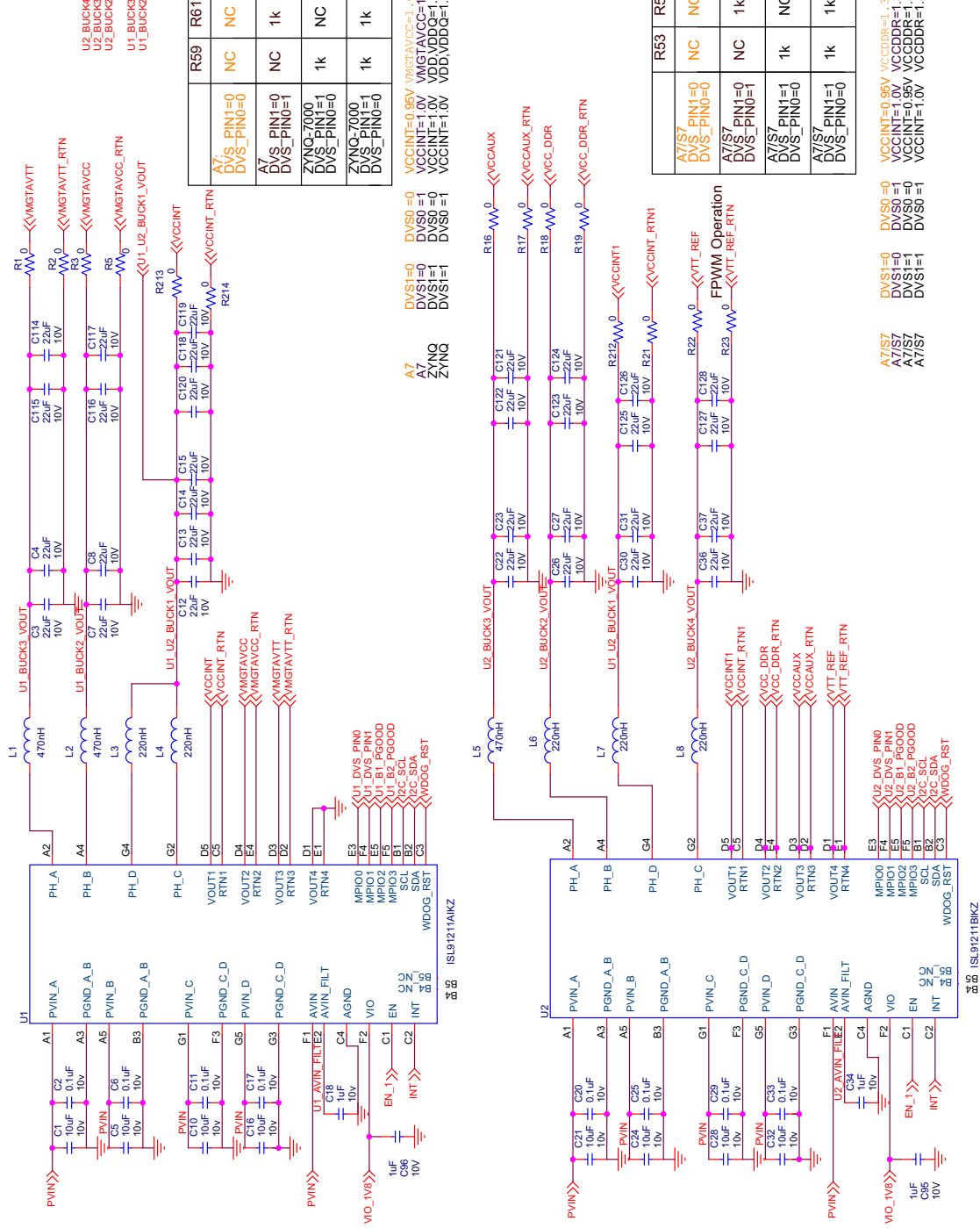
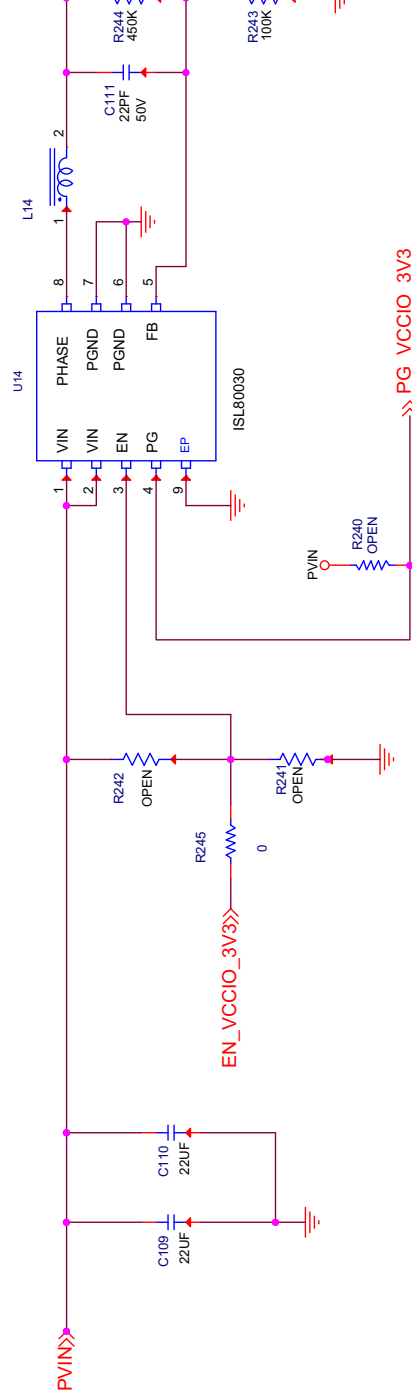

Figure 44. ISL91211AIKZ, ISL91211BIKZ

ISL85003 SINGLE OUTPUT FOR VCCIO 3.3V



FOR ISL80030 PIN 2 IS VIN. PIN 3 IS EN; CONNECT R7=100KOHMS; R8 IS OPEN.

- L=2.2uH R=200K Vout=1.8V
- L=2.2uH R=316K Vout=2.5V
- L=2.2uH R=450K Vout=3.3V

- 2.2uH: 74437324022 Wurth : 4x4x2 mm
- 3.3uH: 74437324033 Wurth : 4X4X2 mm

Figure 45. ISL80030 Single Output for VCCIO 3.3V

ISL80030 SINGLE OUTPUT FOR VCCIO 2.5V

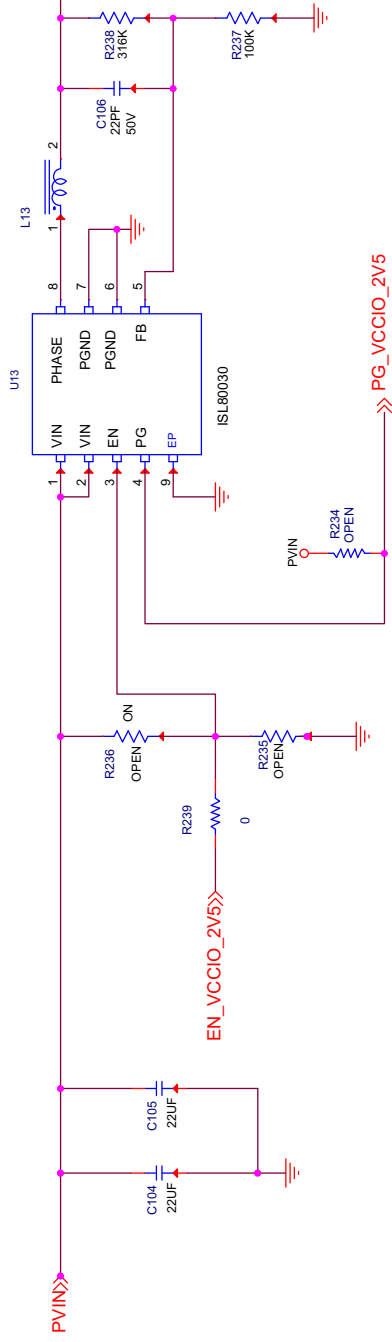

FOR ISL80030 PIN 2 IS VIN. PIN 3 IS EN. CONNECT R7=100KOHMS. R8 IS OPEN.

L=2.2uH R=200K Vout=1.8V  
L=2.2uH R=316K Vout=2.5V  
L=2.2uH R=450K Vout=3.3V

2.2uH: 74437324022 Wurth : 4x4x2 mm  
3.3uH: 74437324033 Wurth : 4X4X2 mm

Figure 46. ISL80030 Single Output for VCCIO 2.5V

ISL80030 SINGLE OUTPUT FOR VCCIO 1.8V

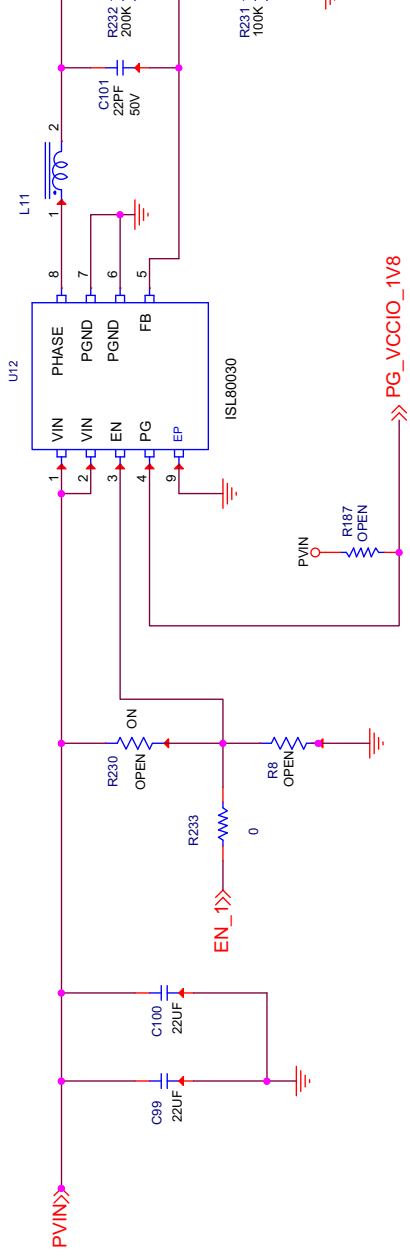

FOR ISL80030 PIN 2 IS VIN. PIN 3 IS EN. CONNECT R7=100KOHMS; R8 IS OPEN.

- L=2.2uH R=200K Vout=1.8V
- L=2.2uH R=316K Vout=2.5V
- L=2.2uH R=450K Vout=3.3V
- 2.2uH: 74437324022 Wurth : 4x4x2 mm
- 3.3uH: 74437324033 Wurth : 4X4X2 mm

Figure 47. ISL80030 Single Output for VCCIO 1.8V

### ISL21010DFH312 for 1.25V reference to FPGA ADC

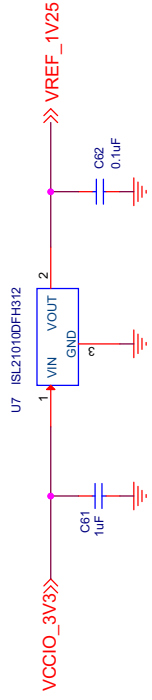

### ISL91231RN for VTT\_REF - FPWM

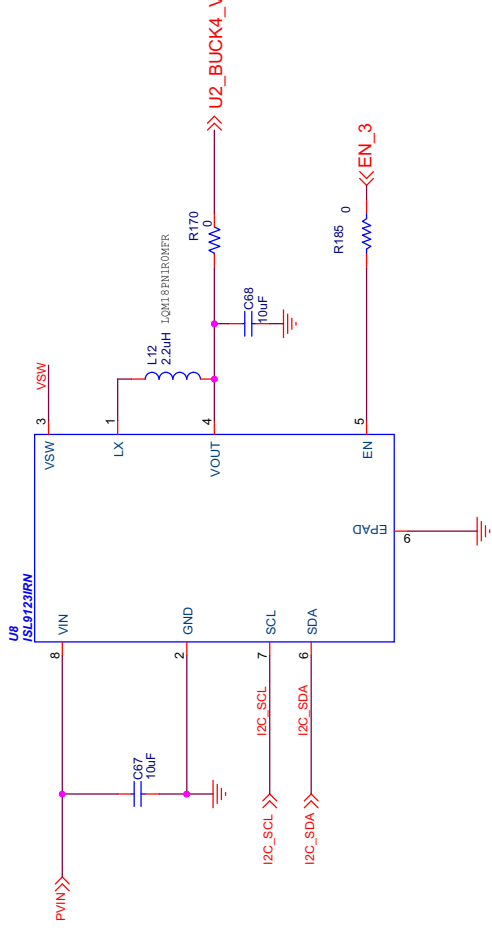

Figure 48. ISL21010DFH312 for 1.25V Reference to FPGA ADC, ISL91231RN for VTT\_REF -

### 3.3 PCB Layout and Bills of Materials

Contact Renesas [support](#) for PCB

## 4. Appendix

### 4.1 ARTIX-7 FPGA Power Solution Selection Table

Xilinx Device	Speed Grade	Renesas PMIC Part Number	DVS_PIN1	DVS_PIN0
XC7A12T	-1	ISL91211BIKZ-TR5877	1	1
XC7A12T	-2	ISL91211BIKZ-TR5877	1	1
XC7A12T	-1L(0.95V)	ISL91211BIKZ-TR5877	0	1
XC7A12T	-1L(0.95V)	ISL91211BIKZ-TR5877	0	1
XC7A12T	-2L	ISL91211BIKZ-TR5877	1	1
XC7A12T	-2L(0.9V)	ISL91211BIKZ-TR5877	0	0
XC7A12T	-3	ISL91211BIKZ-TR5877	1	1
XC7A12T	-3	ISL91211BIKZ-TR5877	1	1
XC7A15T	-1	ISL91211BIKZ-TR5877	1	1
XC7A15T	-2	ISL91211BIKZ-TR5877	1	1
XC7A15T	-1L(0.95V)	ISL91211BIKZ-TR5877	0	1
XC7A15T	-2L	ISL91211BIKZ-TR5877	1	1
XC7A15T	-2L(0.9V)	ISL91211BIKZ-TR5877	0	0
XC7A15T	-3	ISL91211BIKZ-TR5877	1	1
XC7A25T	-1	ISL91211BIKZ-TR5877	1	1
XC7A25T	-2	ISL91211BIKZ-TR5877	1	1
XC7A25T	-1L(0.95V)	ISL91211BIKZ-TR5877	0	1
XC7A25T	-1L(0.95V)	ISL91211BIKZ-TR5877	0	1
XC7A25T	-2L	ISL91211BIKZ-TR5877	1	1
XC7A25T	-2L(0.9V)	ISL91211BIKZ-TR5877	0	0
XC7A25T	-3	ISL91211BIKZ-TR5877	1	1
XC7A35T	-1	ISL91211BIKZ-TR5877	1	1
XC7A35T	-2	ISL91211BIKZ-TR5877	1	1
XC7A35T	-1L(0.95V)	ISL91211BIKZ-TR5877	0	1
XC7A35T	-2L	ISL91211BIKZ-TR5877	1	1
XC7A35T	-2L(0.9V)	ISL91211BIKZ-TR5877	0	0
XC7A35T	-3	ISL91211BIKZ-TR5877	1	1
XC7A50T	-1	ISL91211BIKZ-TR5877	1	1
XC7A50T	-2	ISL91211BIKZ-TR5877	1	1
XC7A50T	-1L(0.95V)	ISL91211BIKZ-TR5877	0	1
XC7A50T	-2L	ISL91211BIKZ-TR5877	1	1
XC7A50T	-2L(0.9V)	ISL91211BIKZ-TR5877	0	0
XC7A50T	-3	ISL91211BIKZ-TR5877	1	1
XC7A75T	-1	ISL91211BIKZ-TR5877	1	1
XC7A75T	-2	ISL91211BIKZ-TR5877	1	1
XC7A75T	-1L(0.95V)	ISL91211BIKZ-TR5877	0	1
XC7A75T	-2L	ISL91211BIKZ-TR5877	1	1
XC7A75T	-2L(0.9V)	ISL91211BIKZ-TR5877	0	0
XC7A75T	-3	ISL91211BIKZ-TR5877	1	1

Xilinx Device	Speed Grade	Renesas PMIC Part Number	DVS_PIN1	DVS_PIN0
XC7A75T	-2L	ISL91211BIKZ-TR5877	1	1
XC7A100T	-1	ISL91211BIKZ-TR5877	1	1
XC7A100T	-2	ISL91211BIKZ-TR5877	1	1
XC7A100T	-1L(0.95V)	ISL91211BIKZ-TR5877	0	1
XC7A100T	-2L	ISL91211BIKZ-TR5877	1	1
XC7A100T	-2L(0.9V)	ISL91211BIKZ-TR5877	0	0
XC7A100T	-3	ISL91211BIKZ-TR5877	1	1
XC7A200T	-1	ISL91211AIKZ-TR5873	0	1
XC7A200T	-2	ISL91211AIKZ-TR5873	0	1
XC7A200T	-1L(0.95V)	ISL91211AIKZ-TR5873	0	0
XC7A200T	-2L	ISL91211AIKZ-TR5873	0	1
XC7A200T	-3	ISL91211AIKZ-TR5873	0	1

## 4.2 Spartan-7 FPGA Power Solution Selection Table

Xilinx Device	Speed Grade	Renesas PMIC Part Number	DVS_PIN1	DVS_PIN0
XC7S6	-1	ISL91211BIKZ-TR5878	1	1
XC7S6	-2	ISL91211BIKZ-TR5878	1	1
XC7S6	-1L(0.95V)	ISL91211BIKZ-TR5878	1	0
XC7S15	-1	ISL91211BIKZ-TR5878	1	1
XC7S15	-2	ISL91211BIKZ-TR5878	1	1
XC7S15	-1L(0.95V)	ISL91211BIKZ-TR5878	1	0
XC7S25	-1	ISL91211BIKZ-TR5878	1	1
XC7S25	-2	ISL91211BIKZ-TR5878	1	1
XC7S25	-1L(0.95V)	ISL91211BIKZ-TR5878	1	0
XC7S50	-1	ISL91211BIKZ-TR5878	1	1
XC7S50	-2	ISL91211BIKZ-TR5878	1	1
XC7S50	-1L(0.95V)	ISL91211BIKZ-TR5878	1	0
XC7S75	-1	ISL91211BIKZ-TR5878	1	1
XC7S75	-2	ISL91211BIKZ-TR5878	1	1
XC7S75	-1L(0.95V)	ISL91211BIKZ-TR5878	1	0
XC7S100	-1	ISL91211BIKZ-TR5878	1	1
XC7S100	-2	ISL91211BIKZ-TR5878	1	1
XC7S100	-1L(0.95V)	ISL91211BIKZ-TR5878	1	0

---

## 5. Revision History

Rev.	Date	Description
1.00	Jan.30.20	Initial release

## Notice

1. Descriptions of circuits, software and other related information in this document are provided only to illustrate the operation of semiconductor products and application examples. You are fully responsible for the incorporation or any other use of the circuits, software, and information in the design of your product or system. Renesas Electronics disclaims any and all liability for any losses and damages incurred by you or third parties arising from the use of these circuits, software, or information.
2. Renesas Electronics hereby expressly disclaims any warranties against and liability for infringement or any other claims involving patents, copyrights, or other intellectual property rights of third parties, by or arising from the use of Renesas Electronics products or technical information described in this document, including but not limited to, the product data, drawings, charts, programs, algorithms, and application examples.
3. No license, express, implied or otherwise, is granted hereby under any patents, copyrights or other intellectual property rights of Renesas Electronics or others.
4. You shall not alter, modify, copy, or reverse engineer any Renesas Electronics product, whether in whole or in part. Renesas Electronics disclaims any and all liability for any losses or damages incurred by you or third parties arising from such alteration, modification, copying or reverse engineering.
5. Renesas Electronics products are classified according to the following two quality grades: "Standard" and "High Quality". The intended applications for each Renesas Electronics product depends on the product's quality grade, as indicated below.
  - "Standard": Computers; office equipment; communications equipment; test and measurement equipment; audio and visual equipment; home electronic appliances; machine tools; personal electronic equipment; industrial robots; etc.
  - "High Quality": Transportation equipment (automobiles, trains, ships, etc.); traffic control (traffic lights); large-scale communication equipment; key financial terminal systems; safety control equipment; etc.Unless expressly designated as a high reliability product or a product for harsh environments in a Renesas Electronics data sheet or other Renesas Electronics document, Renesas Electronics products are not intended or authorized for use in products or systems that may pose a direct threat to human life or bodily injury (artificial life support devices or systems; surgical implantations; etc.), or may cause serious property damage (space system; undersea repeaters; nuclear power control systems; aircraft control systems; key plant systems; military equipment; etc.). Renesas Electronics disclaims any and all liability for any damages or losses incurred by you or any third parties arising from the use of any Renesas Electronics product that is inconsistent with any Renesas Electronics data sheet, user's manual or other Renesas Electronics document.
6. When using Renesas Electronics products, refer to the latest product information (data sheets, user's manuals, application notes, "General Notes for Handling and Using Semiconductor Devices" in the reliability handbook, etc.), and ensure that usage conditions are within the ranges specified by Renesas Electronics with respect to maximum ratings, operating power supply voltage range, heat dissipation characteristics, installation, etc. Renesas Electronics disclaims any and all liability for any malfunctions, failure or accident arising out of the use of Renesas Electronics products outside of such specified ranges.
7. Although Renesas Electronics endeavors to improve the quality and reliability of Renesas Electronics products, semiconductor products have specific characteristics, such as the occurrence of failure at a certain rate and malfunctions under certain use conditions. Unless designated as a high reliability product or a product for harsh environments in a Renesas Electronics data sheet or other Renesas Electronics document, Renesas Electronics products are not subject to radiation resistance design. You are responsible for implementing safety measures to guard against the possibility of bodily injury, injury or damage caused by fire, and/or danger to the public in the event of a failure or malfunction of Renesas Electronics products, such as safety design for hardware and software, including but not limited to redundancy, fire control and malfunction prevention, appropriate treatment for aging degradation or any other appropriate measures. Because the evaluation of microcomputer software alone is very difficult and impractical, you are responsible for evaluating the safety of the final products or systems manufactured by you.
8. Please contact a Renesas Electronics sales office for details as to environmental matters such as the environmental compatibility of each Renesas Electronics product. You are responsible for carefully and sufficiently investigating applicable laws and regulations that regulate the inclusion or use of controlled substances, including without limitation, the EU RoHS Directive, and using Renesas Electronics products in compliance with all these applicable laws and regulations. Renesas Electronics disclaims any and all liability for damages or losses occurring as a result of your noncompliance with applicable laws and regulations.
9. Renesas Electronics products and technologies shall not be used for or incorporated into any products or systems whose manufacture, use, or sale is prohibited under any applicable domestic or foreign laws or regulations. You shall comply with any applicable export control laws and regulations promulgated and administered by the governments of any countries asserting jurisdiction over the parties or transactions.
10. It is the responsibility of the buyer or distributor of Renesas Electronics products, or any other party who distributes, disposes of, or otherwise sells or transfers the product to a third party, to notify such third party in advance of the contents and conditions set forth in this document.
11. This document shall not be reprinted, reproduced or duplicated in any form, in whole or in part, without prior written consent of Renesas Electronics.
12. Please contact a Renesas Electronics sales office if you have any questions regarding the information contained in this document or Renesas Electronics products.

(Note1) "Renesas Electronics" as used in this document means Renesas Electronics Corporation and also includes its directly or indirectly controlled subsidiaries.

(Note2) "Renesas Electronics product(s)" means any product developed or manufactured by or for Renesas Electronics.

(Rev.4.0-1 November 2017)

## Corporate Headquarters

TOYOSU FORESIA, 3-2-24 Toyosu,  
Koto-ku, Tokyo 135-0061, Japan  
[www.renesas.com](http://www.renesas.com)

## Contact Information

For further information on a product, technology, the most up-to-date version of a document, or your nearest sales office, please visit:  
[www.renesas.com/contact/](http://www.renesas.com/contact/)

## Trademarks

Renesas and the Renesas logo are trademarks of Renesas Electronics Corporation. All trademarks and registered trademarks are the property of their respective owners.



ISL91211A-BIK-REFZ,  
ISL91211AIK-REFZ, ISL91211BIK-  
REF2Z

## Looking for pricing, stock, or lifecycle information?

Click below to explore more details on WIN SOURCE:

-  [View ISL91211AIK-REFZ on WIN SOURCE](#)
-  [Renesas Electronics America Information](#)

## Optimize Your Supply Chain with WIN SOURCE Solutions

-  Global Sourcing Solution
-  Obsolete Management
-  Cost Control Management
-  Shortage Management
-  Alternative Solution
-  Excess Inventory Management