



THE DATASHEET OF NCV317MABSTT3G



LM317M, NCV317MA, NCV317M

Voltage Regulator - Adjustable Output, Positive

500 mA

The LM317M is an adjustable three-terminal positive voltage regulator capable of supplying in excess of 500 mA over an output voltage range of 1.2 V to 37 V. This voltage regulator is exceptionally easy to use and requires only two external resistors to set the output voltage. Further, it employs internal current limiting, thermal shutdown and safe area compensation, making it essentially blow-out proof.

The LM317M serves a wide variety of applications including local, on-card regulation. This device also makes an especially simple adjustable switching regulator, a programmable output regulator, or by connecting a fixed resistor between the adjustment and output, the LM317M can be used as a precision current regulator.

Features

- Output Current in Excess of 500 mA
- Output Adjustable between 1.2 V and 37 V
- Internal Thermal Overload Protection
- Internal Short Circuit Current Limiting
- Output Transistor Safe-Area Compensation
- Floating Operation for High Voltage Applications
- Eliminates Stocking Many Fixed Voltages
- NCV Prefix for Automotive and Other Applications Requiring Unique Site and Control Change Requirements; AEC-Q100 Qualified and PPAP Capable
- These are Pb-Free Devices

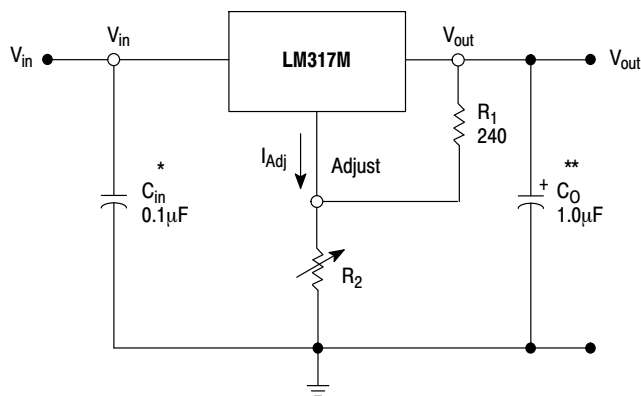

* = C_{in} is required if regulator is located an appreciable distance from power supply filter.
** = C_o is not needed for stability, however, it does improve transient response.

$$V_{out} = 1.25 V \left(1 + \frac{R_2}{R_1} \right) + I_{Adj} R_2$$

Since I_{Adj} is controlled to less than 100 μA , the error associated with this term is negligible in most applications.

Figure 1. Simplified Application



ON Semiconductor®

www.onsemi.com

Heatsink surface
connected to Pin 2

TO-220AB
T SUFFIX
CASE 221AB

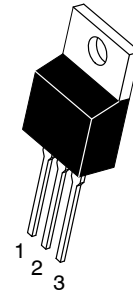

SOT-223
ST SUFFIX
CASE 318E



DPAK
DT SUFFIX
CASE 369C

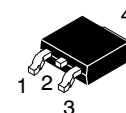

Heatsink Surface (shown as terminal 4 in
case outline drawing) is connected to Pin 2.

PIN ASSIGNMENT

PIN ASSIGNMENT	
1	Adjust
2	V_{out}
3	V_{in}

ORDERING INFORMATION

See detailed ordering and shipping information in the package dimensions section on page 10 of this data sheet.

DEVICE MARKING INFORMATION

See general marking information in the device marking section on page 11 of this data sheet.

LM317M, NCV317MA, NCV317M

MAXIMUM RATINGS (T_A = 25°C, unless otherwise noted.)

Rating	Symbol	Value	Unit
Input-Output Voltage Differential	V _I -V _O	40	Vdc
Power Dissipation (Package Limitation) (Note 1)			
Plastic Package, T Suffix, Case 221A			
T _A = 25°C	P _D	Internally Limited	
Thermal Resistance, Junction-to-Air	θ _{JA}	70	°C/W
Thermal Resistance, Junction-to-Case	θ _{JC}	5.0	°C/W
Plastic Package, DT Suffix, Case 369C			
T _A = 25°C	P _D	Internally Limited	
Thermal Resistance, Junction-to-Air	θ _{JA}	92	°C/W
Thermal Resistance, Junction-to-Case	θ _{JC}	5.0	°C/W
Plastic Package, ST Suffix, Case 318E			
T _A = 25°C	P _D	Internally Limited	
Thermal Resistance, Junction-to-Air	θ _{JA}	245	°C/W
Thermal Resistance, Junction-to-Case	θ _{JC}	15	°C/W
Maximum Junction Temperature	T _{JMAX}	+150	°C
Storage Temperature Range	T _{stg}	-65 to +150	°C

Stresses exceeding those listed in the Maximum Ratings table may damage the device. If any of these limits are exceeded, device functionality should not be assumed, damage may occur and reliability may be affected.

1. Figure 25 provides thermal resistance versus PC board pad size.

ELECTRICAL CHARACTERISTICS (V_I - V_O = 5.0 V; I_O = 0.1 A, T_J = T_{low} to T_{high} (Note 2), unless otherwise noted.)

Characteristics	Figure	Symbol	LM317M/LM317MB/NCV317MB			Unit
			Min	Typ	Max	
Line Regulation (Note 3) (T _A = 25°C, 3.0 V ≤ V _I - V _O ≤ 40 V)	3	Reg _{line}	-	0.01	0.04	%/V
Load Regulation (Note 3)	4	Reg _{load}				
T _A = 25°C, 10 mA ≤ I _O ≤ 0.5 A				5.0	25	mV
V _O ≤ 5.0 V			-	0.1	0.5	% V _O
V _O ≥ 5.0 V						
Adjustment Pin Current	5	I _{Adj}	-	50	100	μA
Adjustment Pin Current Change	3, 4	ΔI _{Adj}	-	0.2	5.0	μA
2.5 V ≤ V _I - V _O ≤ 40 V, 10 mA ≤ I _L ≤ 0.5 A, P _D ≤ P _{max}						
Reference Voltage	5	V _{ref}	1.20	1.25	1.30	V
3.0 V ≤ V _I - V _O ≤ 40 V, 10 mA ≤ I _L ≤ 0.5 A, P _D ≤ P _{max}						
Line Regulation 3.0 V ≤ V _I - V _O ≤ 40 V (Note 3)	3	Reg _{line}	-	0.02	0.07	%/V
Load Regulation 10 mA ≤ I _O ≤ 0.5 A (Note 3)	4	Reg _{load}				
V _O ≤ 5.0 V			-	20	70	mV
V _O ≥ 5.0 V			-	0.3	1.5	% V _O
Temperature Stability (T _{low} ≤ T _J ≤ T _{high})	5	T _S	-	0.7	-	% V _O
Minimum Load Current to Maintain Regulation (V _I - V _O = 40 V)	5	I _{Lmin}	-	3.5	10	mA
Maximum Output Current	5	I _{max}				A
V _I - V _O ≤ 15 V, P _D ≤ P _{max}			0.5	0.9	-	
V _I - V _O = 40 V, P _D ≤ P _{max} , T _A = 25°C			0.15	0.25	-	
RMS Noise, % of V _O (T _A = 25°C, 10 Hz ≤ f ≤ 10 kHz)	-	N	-	0.003	-	% V _O
Ripple Rejection, V _O = 10 V, f = 120 Hz (Note 4)	6	RR				dB
Without C _{Adj}			-	65	-	
C _{Adj} = 10 μF			66	80	-	
Thermal Shutdown (Note 5)	-	-	-	180	-	°C
Long-Term Stability, T _J = T _{high} (Note 6)	5	S	-	0.3	1.0	%/1.0 kHrs.
T _A = 25°C for End-point Measurements						

2. T_{low} to T_{high} = 0° to +125°C for LM317M T_{low} to T_{high} = -40° to +125°C for LM317MB, NCV317MB.

3. Load and line regulation are specified at constant junction temperature. Changes in V_O due to heating effects must be taken into account separately. Pulse testing with low duty cycle is used.

4. C_{Adj}, when used, is connected between the adjustment pin and ground.

5. Thermal characteristics are not subject to production test.

6. Since Long-Term Stability cannot be measured on each device before shipment, this specification is an engineering estimate of average stability from lot-to-lot.

LM317M, NCV317MA, NCV317M

ELECTRICAL CHARACTERISTICS ($V_I - V_O = 5.0\text{ V}$; $I_O = 0.1\text{ A}$, $T_J = T_{\text{low}}$ to T_{high} (Note 7), unless otherwise noted.)

Characteristics	Figure	Symbol	LM317M/LM317MAB/NCV317MAB			Unit
			Min	Typ	Max	
Line Regulation (Note 8) ($T_A = 25^\circ\text{C}$, $3.0\text{ V} \leq V_I - V_O \leq 40\text{ V}$)	3	Reg_{line}	–	0.01	0.04	%/V
Load Regulation (Note 8) $T_A = 25^\circ\text{C}$, $10\text{ mA} \leq I_O \leq 0.5\text{ A}$ $V_O \leq 5.0\text{ V}$ $V_O \geq 5.0\text{ V}$	4	Reg_{load}	– –	5.0 0.1	25 0.5	mV % V_O
Adjustment Pin Current	5	I_{Adj}	–	50	100	μA
Adjustment Pin Current Change $2.5\text{ V} \leq V_I - V_O \leq 40\text{ V}$, $10\text{ mA} \leq I_L \leq 0.5\text{ A}$, $P_D \leq P_{\text{max}}$	3, 4	ΔI_{Adj}	–	0.2	5.0	μA
Reference Voltage $3.0\text{ V} \leq V_I - V_O \leq 40\text{ V}$, $10\text{ mA} \leq I_L \leq 0.5\text{ A}$, $P_D \leq P_{\text{max}}$	5	V_{ref}	1.225	1.250	1.275	V
Line Regulation (Note 8) $3.0\text{ V} \leq V_I - V_O \leq 40\text{ V}$	3	Reg_{line}	–	0.02	0.07	%/V
Load Regulation (Note 8) $10\text{ mA} \leq I_O \leq 0.5\text{ A}$ $V_O \leq 5.0\text{ V}$ $V_O \geq 5.0\text{ V}$	4	Reg_{load}	– –	20 0.3	70 1.5	mV % V_O
Temperature Stability ($T_{\text{low}} \leq T_J \leq T_{\text{high}}$)	5	T_S	–	0.7	–	% V_O
Minimum Load Current to Maintain Regulation ($V_I - V_O = 40\text{ V}$)	5	I_{Lmin}	–	3.5	10	mA
Maximum Output Current $V_I - V_O \leq 15\text{ V}$, $P_D \leq P_{\text{max}}$ $V_I - V_O = 40\text{ V}$, $P_D \leq P_{\text{max}}$, $T_A = 25^\circ\text{C}$	5	I_{max}	0.5 0.15	0.9 0.25	– –	A
RMS Noise, % of V_O ($T_A = 25^\circ\text{C}$, $10\text{ Hz} \leq f \leq 10\text{ kHz}$)	–	N	–	–	–	% V_O
Ripple Rejection, $V_O = 10\text{ V}$, $f = 120\text{ Hz}$ (Note 9) Without C_{Adj} $C_{\text{Adj}} = 10\text{ }\mu\text{F}$	6	RR	– 66	65 80	– –	dB
Thermal Shutdown (Note 10)	–	–	–	180	–	$^\circ\text{C}$
Long-Term Stability, $T_J = T_{\text{high}}$ (Note 11) $T_A = 25^\circ\text{C}$ for End-point Measurements	5	S	–	0.3	1.0	%/1.0 kHrs.

7. T_{low} to $T_{\text{high}} = 0^\circ$ to $+125^\circ\text{C}$ for LM317MA T_{low} to $T_{\text{high}} = -40^\circ$ to $+125^\circ\text{C}$ for LM317MAB, NCV317MAB.

8. Load and line regulation are specified at constant junction temperature. Changes in V_O due to heating effects must be taken into account separately. Pulse testing with low duty cycle is used.

9. C_{Adj} , when used, is connected between the adjustment pin and ground.

10. Thermal characteristics are not subject to production test.

11. Since Long-Term Stability cannot be measured on each device before shipment, this specification is an engineering estimate of average stability from lot-to-lot.

LM317M, NCV317MA, NCV317M

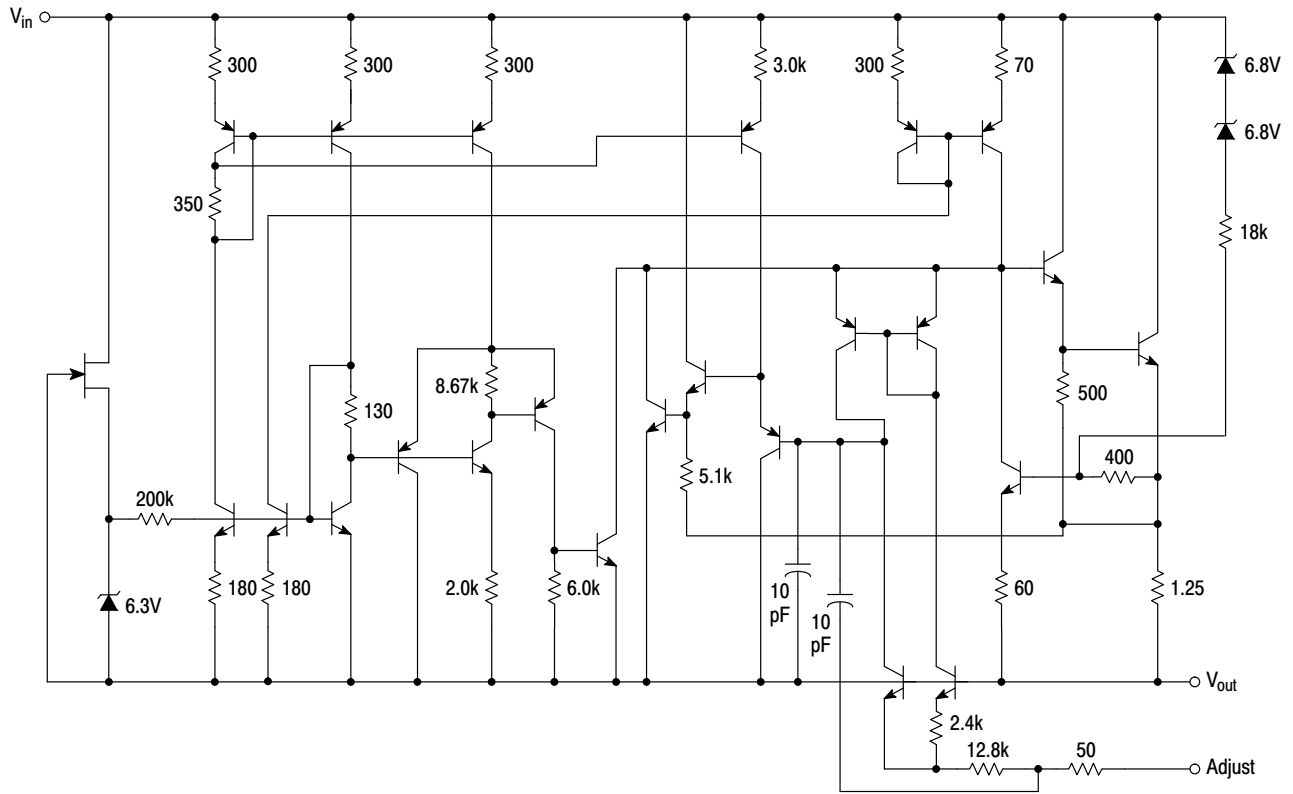

Figure 2. Representative Schematic Diagram

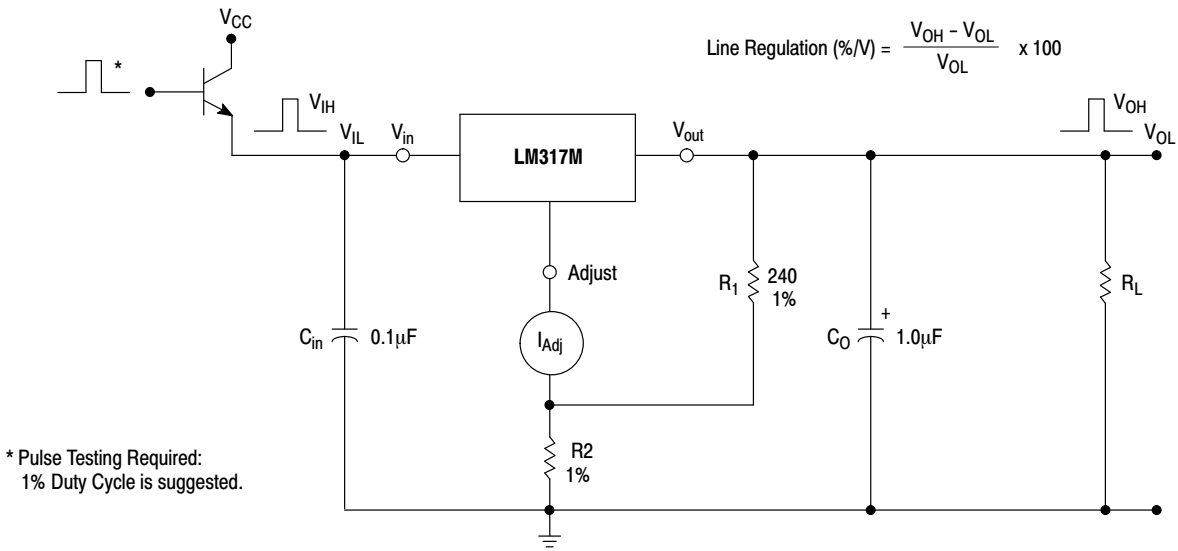
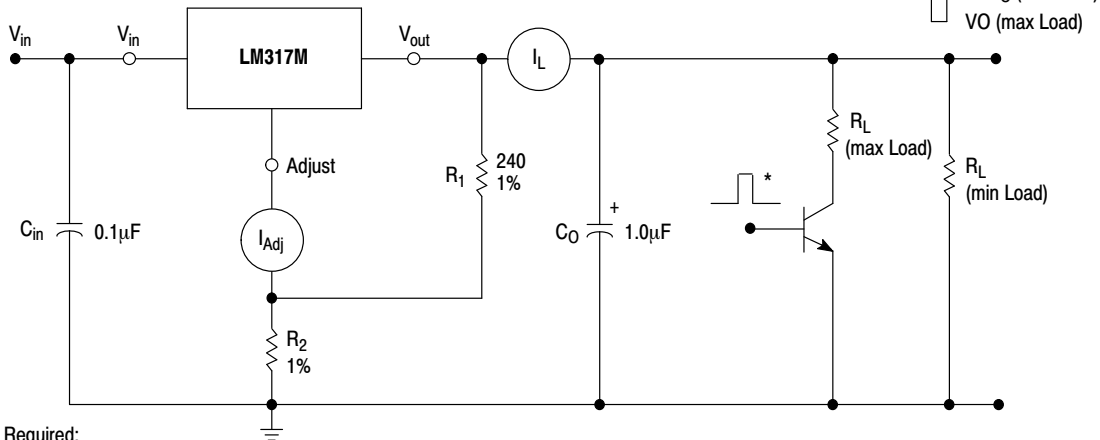

Figure 3. Line Regulation and ΔI_{Adj} /Line Test Circuit

LM317M, NCV317MA, NCV317M

$$\text{Load Regulation (mV)} = V_O (\text{min Load}) - V_O (\text{max Load})$$

$$\text{Load Regulation (\% } V_O) = \frac{V_O (\text{min Load}) - V_O (\text{max Load})}{V_O (\text{min Load})} \times 100$$



* Pulse Testing Required:
1% Duty Cycle is suggested.

Figure 4. Load Regulation and ΔI_{Adj} /Load Test Circuit

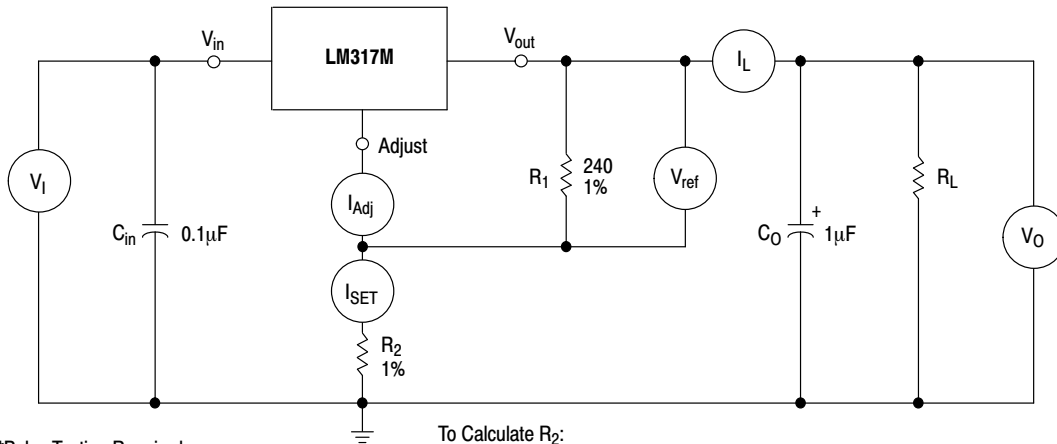

*Pulse Testing Required:
1% Duty Cycle is suggested.

To Calculate R_2 :
 $V_{out} = I_{SET} R_2 + 1.250 \text{ V}$
Assume $I_{SET} = 5.25 \text{ mA}$

Figure 5. Standard Test Circuit

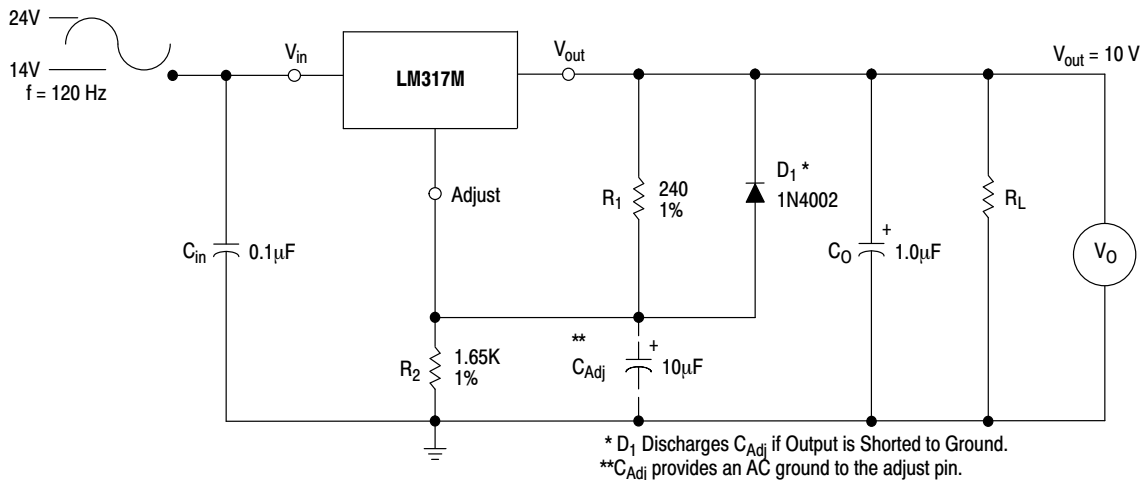

* D_1 Discharges C_{Adj} if Output is Shorted to Ground.
** C_{Adj} provides an AC ground to the adjust pin.

Figure 6. Ripple Rejection Test Circuit

LM317M, NCV317MA, NCV317M

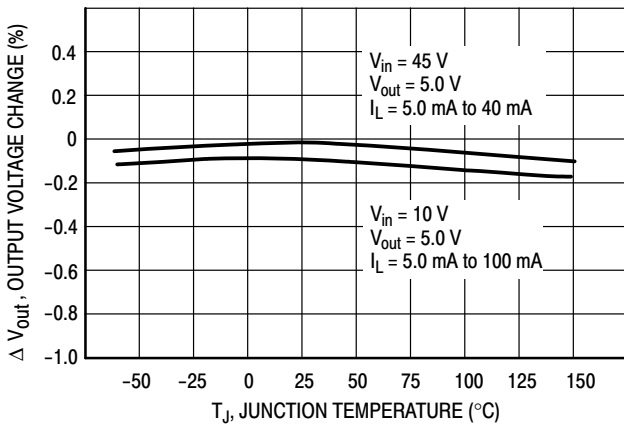

Figure 7. Load Regulation

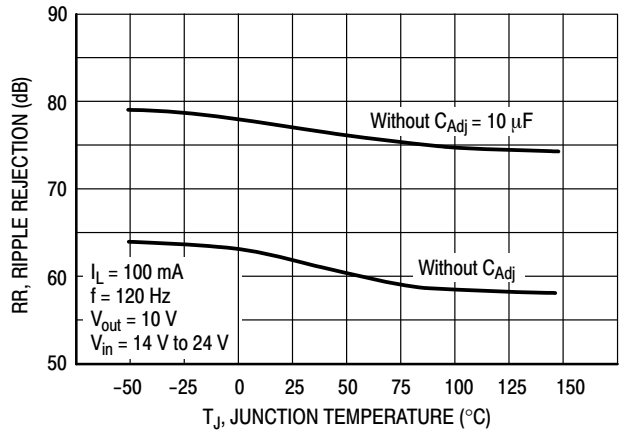

Figure 8. Ripple Rejection

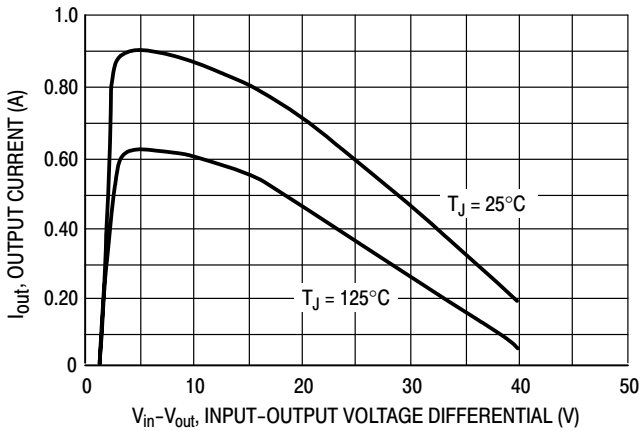

Figure 9. Current Limit

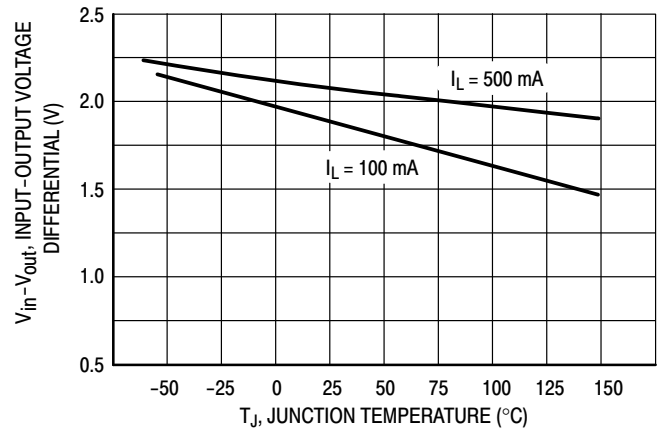

Figure 10. Dropout Voltage

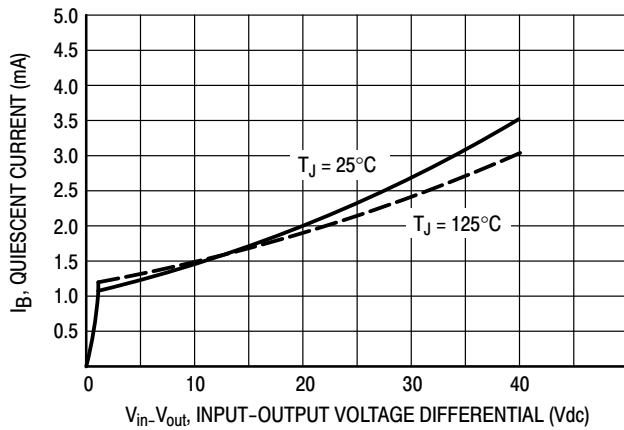

Figure 11. Minimum Operating Current

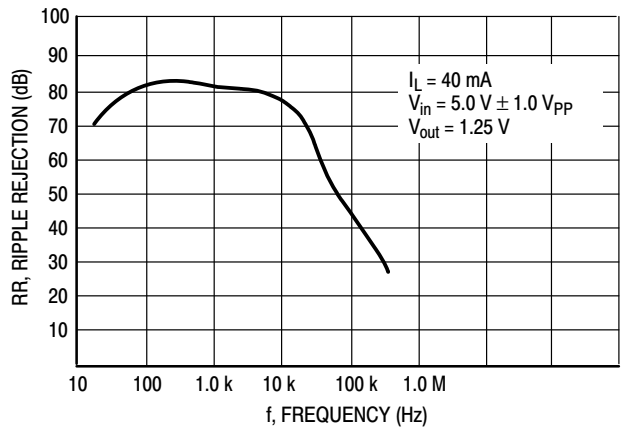

Figure 12. Ripple Rejection versus Frequency

LM317M, NCV317MA, NCV317M

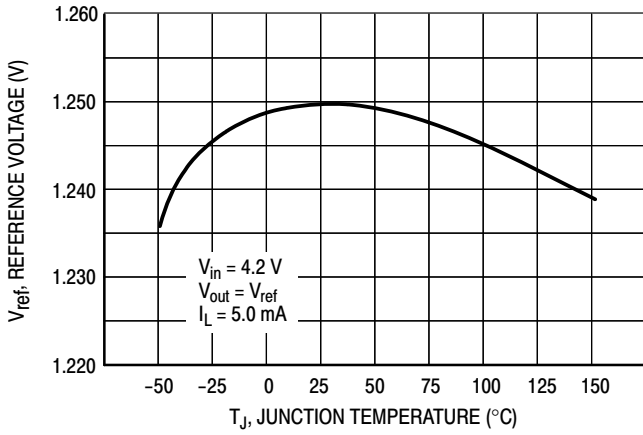

Figure 13. Temperature Stability

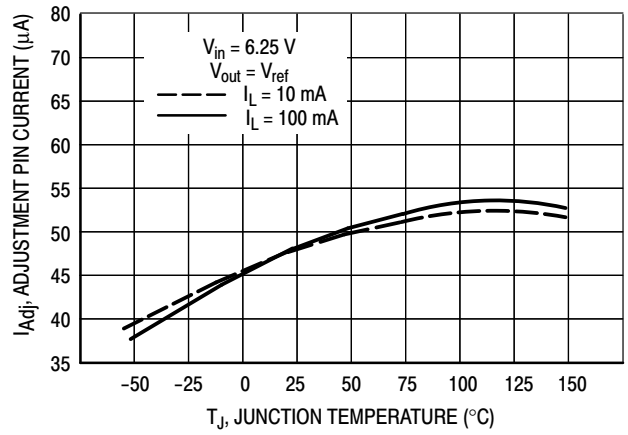

Figure 14. Adjustment Pin Current

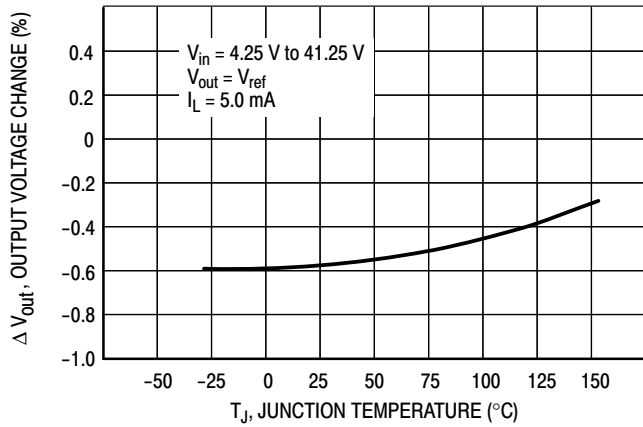

Figure 15. Line Regulation

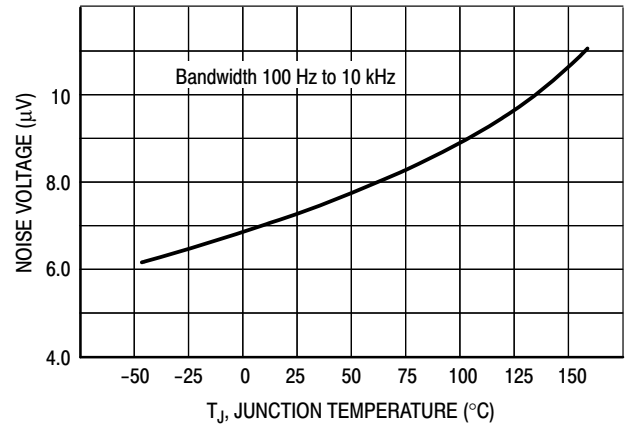

Figure 16. Output Noise

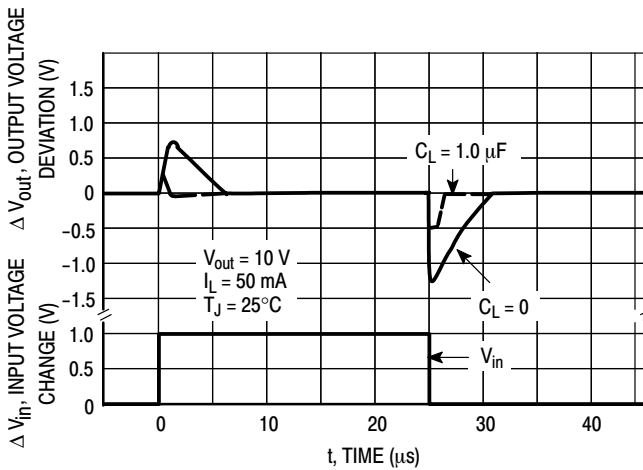

Figure 17. Line Transient Response

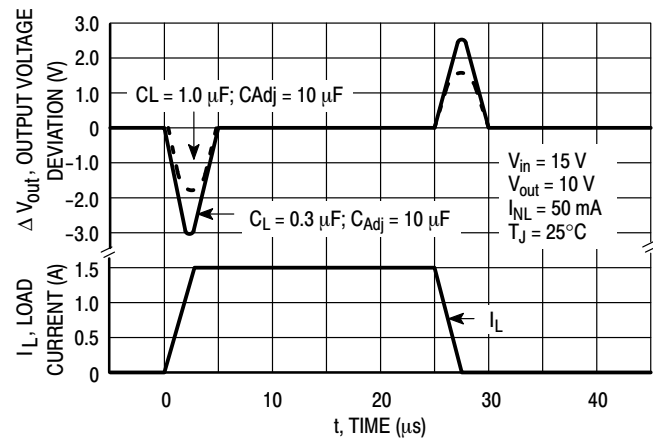

Figure 18. Load Transient Response

APPLICATIONS INFORMATION

Basic Circuit Operation

The LM317M is a three-terminal floating regulator. In operation, the LM317M develops and maintains a nominal 1.25 V reference (V_{ref}) between its output and adjustment terminals. This reference voltage is converted to a programming current (I_{PROG}) by R_1 (see Figure 19), and this constant current flows through R_2 to ground. The regulated output voltage is given by:

$$V_{out} = V_{ref} \left(1 + \frac{R_2}{R_1} \right) + I_{Adj} R_2$$

Since the current from the terminal (I_{Adj}) represents an error term in the equation, the LM317M was designed to control I_{Adj} to less than 100 μ A and keep it constant. To do this, all quiescent operating current is returned to the output terminal. This imposes the requirement for a minimum load current. If the load current is less than this minimum, the output voltage will rise.

Since the LM317M is a floating regulator, it is only the voltage differential across the circuit which is important to performance, and operation at high voltages with respect to ground is possible.

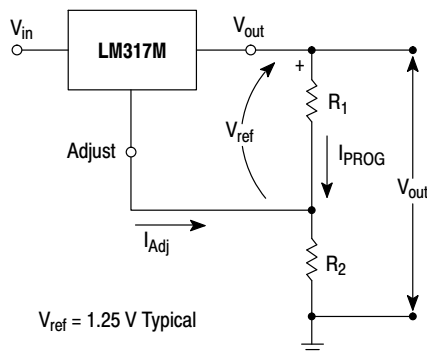

Figure 19. Basic Circuit Configuration

Load Regulation

The LM317M is capable of providing extremely good load regulation, but a few precautions are needed to obtain maximum performance. For best performance, the programming resistor (R_1) should be connected as close to the regulator as possible to minimize line drops which effectively appear in series with the reference, thereby degrading regulation. The ground end of R_2 can be returned near the load ground to provide remote ground sensing and improve load regulation.

External Capacitors

A 0.1 μ F disc or 1.0 μ F tantalum input bypass capacitor (C_{in}) is recommended to reduce the sensitivity to input line impedance.

The adjustment terminal may be bypassed to ground to improve ripple rejection. This capacitor (C_{Adj}) prevents ripple from being amplified as the output voltage is increased. A 10 μ F capacitor should improve ripple rejection about 15 dB at 120 Hz in a 10 V application.

Although the LM317M is stable with no output capacitance, like any feedback circuit, certain values of external capacitance can cause excessive ringing. An output capacitance (C_O) in the form of a 1.0 μ F tantalum or 25 μ F aluminum electrolytic capacitor on the output swamps this effect and insures stability.

Protection Diodes

When external capacitors are used with any IC regulator it is sometimes necessary to add protection diodes to prevent the capacitors from discharging through low current points into the regulator.

Figure 20 shows the LM317M with the recommended protection diodes for output voltages in excess of 25 V or high capacitance values ($C_O > 25 \mu$ F, $C_{Adj} > 5.0 \mu$ F). Diode D_1 prevents C_O from discharging thru the IC during an input short circuit. Diode D_2 protects against capacitor C_{Adj} discharging through the IC during an output short circuit. The combination of diodes D_1 and D_2 prevents C_{Adj} from discharging through the IC during an input short circuit.

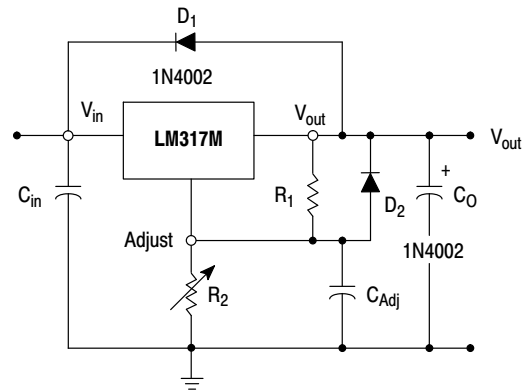

Figure 20. Voltage Regulator with Protection Diodes

LM317M, NCV317MA, NCV317M

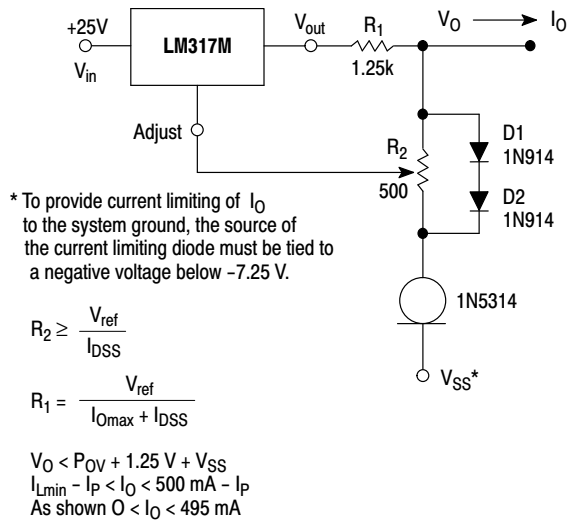
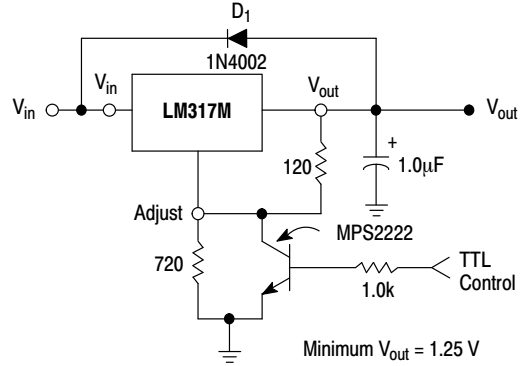

Figure 21. Adjustable Current Limiter



D_1 protects the device during an input short circuit.

Figure 22. 5 V Electronic Shutdown Regulator

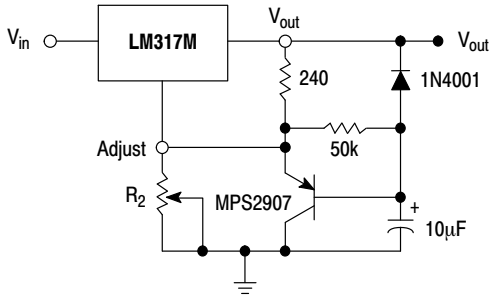

Figure 23. Slow Turn-On Regulator

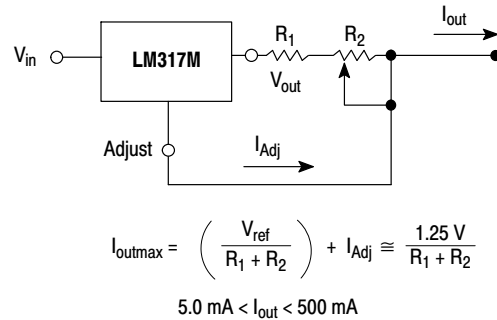

Figure 24. Current Regulator

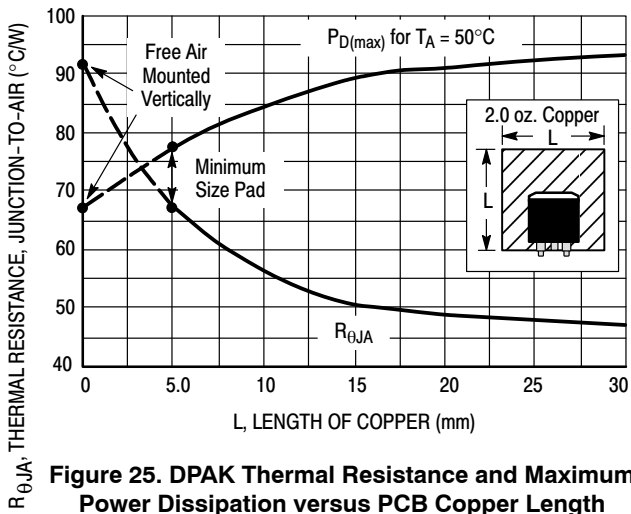

Figure 25. DPAK Thermal Resistance and Maximum Power Dissipation versus PCB Copper Length

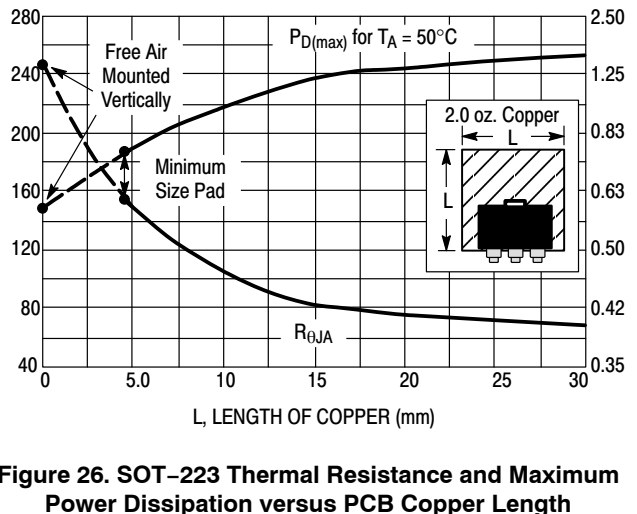

Figure 26. SOT-223 Thermal Resistance and Maximum Power Dissipation versus PCB Copper Length

LM317M, NCV317MA, NCV317M

ORDERING INFORMATION

Device	Output Voltage Tolerance	Operating Temperature Range	Package	Shipping [†]	
LM317MABDTG	2%	$T_J = -40^{\circ}\text{C}$ to 125°C	DAK (Pb-Free)	75 Units / Rail	
LM317MABDTRKG			DAK (Pb-Free)	2500 / Tape & Reel	
NCV317MABDTRKG*			SOT-223 (Pb-Free)	4000 / Tape & Reel	
NCV317MABSTT3G*			TO-220 (Pb-Free)	50 Units / Rail	
LM317MABTG		$T_J = 0^{\circ}\text{C}$ to 125°C	DAK (Pb-Free)	2500 / Tape & Reel	
LM317MADTRKG			DAK (Pb-Free)	2500 / Tape & Reel	
LM317MBDTG	4%	$T_J = -40^{\circ}\text{C}$ to 125°C	DAK (Pb-Free)	75 Units / Rail	
NCV317MBDTG*			DAK (Pb-Free)	2500 / Tape & Reel	
LM317MBDTRKG			SOT-223 (Pb-Free)	4000 / Tape & Reel	
NCV317MBDTRKG*			TO-220 (Pb-Free)	50 Units / Rail	
LM317MBSTT3G			$T_J = 0^{\circ}\text{C}$ to 125°C	DAK (Pb-Free)	75 Units / Rail
NCV317MBSTT3G*				DAK (Pb-Free)	2500 / Tape & Reel
LM317MBTG		SOT-223 (Pb-Free)		4000 / Tape & Reel	
NCV317MBTG*		TO-220 (Pb-Free)		50 Units / Rail	
LM317MDTG		DAK (Pb-Free)		75 Units / Rail	
LM317MDTRKG		DAK (Pb-Free)		2500 / Tape & Reel	
LM317MSTT3G		SOT-223 (Pb-Free)		4000 / Tape & Reel	
LM317MTG		TO-220 (Pb-Free)		50 Units / Rail	

[†]For information on tape and reel specifications, including part orientation and tape sizes, please refer to our Tape and Reel Packaging Specification Brochure, BRD8011/D.

*NCV devices: $T_{low} = -40^{\circ}\text{C}$, $T_{high} = +125^{\circ}\text{C}$. Guaranteed by design. NCV Prefix for Automotive and Other Applications Requiring Unique Site and Control Change Requirements; AEC-Q100 Qualified and PPAP Capable.

LM317M, NCV317MA, NCV317M

MARKING DIAGRAMS

DPAK DT SUFFIX CASE 369C

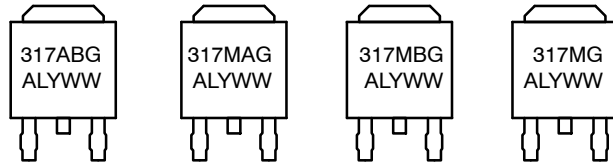

TO-220 T SUFFIX CASE 221A

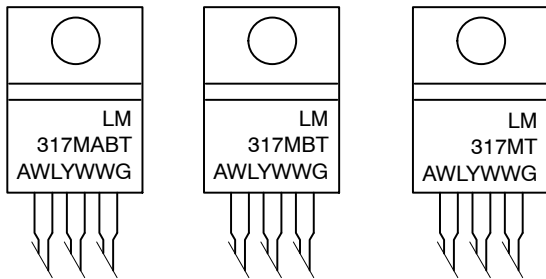

SOT-223 ST SUFFIX CASE 318E

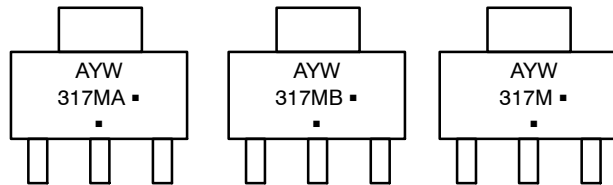

A = Assembly Location
L, WL = Wafer Lot
Y = Year
WW, W = Work Week
G or ■ = Pb-Free Package
(Note: Microdot may be in either location)

MECHANICAL CASE OUTLINE

PACKAGE DIMENSIONS

ON Semiconductor®



SCALE 1:1

SOT-223 (TO-261)
CASE 318E-04
ISSUE R

DATE 02 OCT 2018

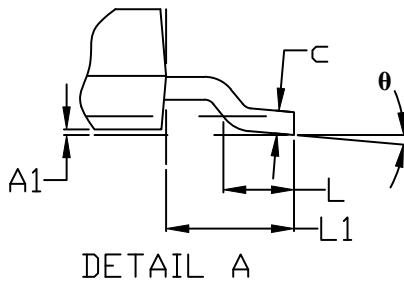
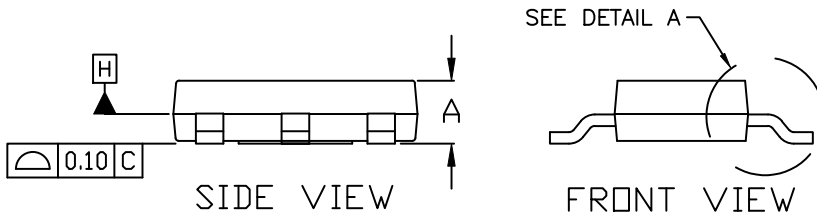
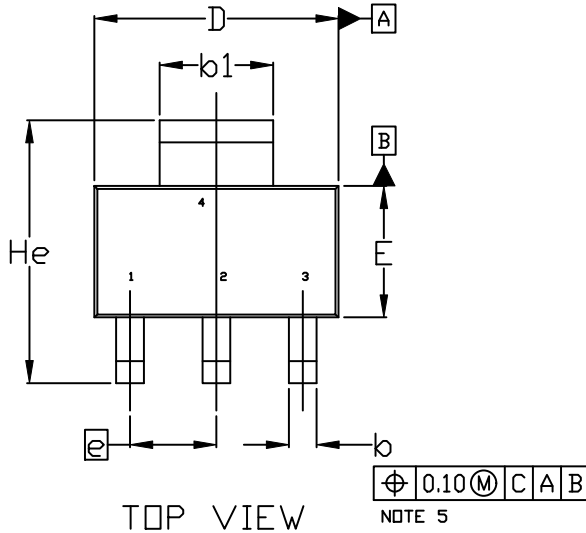

NOTES:

1. DIMENSIONING AND TOLERANCING PER ASME Y14.5M, 1994.
2. CONTROLLING DIMENSION: MILLIMETERS
3. DIMENSIONS D & E DO NOT INCLUDE MOLD FLASH, PROTRUSIONS OR GATE BURRS. MOLD FLASH, PROTRUSIONS OR GATE BURRS SHALL NOT EXCEED 0.200MM PER SIDE.
4. DATUMS A AND B ARE DETERMINED AT DATUM H.
5. A1 IS DEFINED AS THE VERTICAL DISTANCE FROM THE SEATING PLANE TO THE LOWEST POINT OF THE PACKAGE BODY.
6. POSITIONAL TOLERANCE APPLIES TO DIMENSIONS b AND b1.

MILLIMETERS			
DIM	MIN.	NOM.	MAX.
A	1.50	1.63	1.75
A1	0.02	0.06	0.10
b	0.60	0.75	0.89
b1	2.90	3.06	3.20
c	0.24	0.29	0.35
D	6.30	6.50	6.70
E	3.30	3.50	3.70
e	2.30 BSC		
L	0.20	---	---
L1	1.50	1.75	2.00
He	6.70	7.00	7.30
θ	0°	---	10°

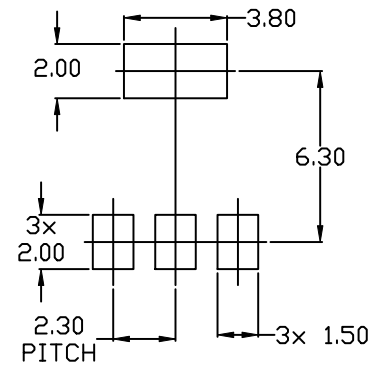

DOCUMENT NUMBER:	98ASB42680B	Electronic versions are uncontrolled except when accessed directly from the Document Repository. Printed versions are uncontrolled except when stamped "CONTROLLED COPY" in red.
DESCRIPTION:	SOT-223 (TO-261)	PAGE 1 OF 2

ON Semiconductor and are trademarks of Semiconductor Components Industries, LLC dba ON Semiconductor or its subsidiaries in the United States and/or other countries. ON Semiconductor reserves the right to make changes without further notice to any products herein. ON Semiconductor makes no warranty, representation or guarantee regarding the suitability of its products for any particular purpose, nor does ON Semiconductor assume any liability arising out of the application or use of any product or circuit, and specifically disclaims any and all liability, including without limitation special, consequential or incidental damages. ON Semiconductor does not convey any license under its patent rights nor the rights of others.

SOT-223 (TO-261)
CASE 318E-04
ISSUE R

DATE 02 OCT 2018

- | | | | | |
|--|---|---|---|---|
| STYLE 1:
PIN 1. BASE
2. COLLECTOR
3. EMITTER
4. COLLECTOR | STYLE 2:
PIN 1. ANODE
2. CATHODE
3. NC
4. CATHODE | STYLE 3:
PIN 1. GATE
2. DRAIN
3. SOURCE
4. DRAIN | STYLE 4:
PIN 1. SOURCE
2. DRAIN
3. GATE
4. DRAIN | STYLE 5:
PIN 1. DRAIN
2. GATE
3. SOURCE
4. GATE |
| STYLE 6:
PIN 1. RETURN
2. INPUT
3. OUTPUT
4. INPUT | STYLE 7:
PIN 1. ANODE 1
2. CATHODE
3. ANODE 2
4. CATHODE | STYLE 8:
CANCELLED | STYLE 9:
PIN 1. INPUT
2. GROUND
3. LOGIC
4. GROUND | STYLE 10:
PIN 1. CATHODE
2. ANODE
3. GATE
4. ANODE |
| STYLE 11:
PIN 1. MT 1
2. MT 2
3. GATE
4. MT 2 | STYLE 12:
PIN 1. INPUT
2. OUTPUT
3. NC
4. OUTPUT | STYLE 13:
PIN 1. GATE
2. COLLECTOR
3. EMITTER
4. COLLECTOR | | |

**GENERIC
 MARKING DIAGRAM***



- A = Assembly Location
- Y = Year
- W = Work Week
- XXXXX = Specific Device Code
- = Pb-Free Package

(Note: Microdot may be in either location)

*This information is generic. Please refer to device data sheet for actual part marking. Pb-Free indicator, "G" or microdot "▪", may or may not be present. Some products may not follow the Generic Marking.

DOCUMENT NUMBER:	98ASB42680B	Electronic versions are uncontrolled except when accessed directly from the Document Repository. Printed versions are uncontrolled except when stamped "CONTROLLED COPY" in red.
DESCRIPTION:	SOT-223 (TO-261)	PAGE 2 OF 2

ON Semiconductor and  are trademarks of Semiconductor Components Industries, LLC dba ON Semiconductor or its subsidiaries in the United States and/or other countries. ON Semiconductor reserves the right to make changes without further notice to any products herein. ON Semiconductor makes no warranty, representation or guarantee regarding the suitability of its products for any particular purpose, nor does ON Semiconductor assume any liability arising out of the application or use of any product or circuit, and specifically disclaims any and all liability, including without limitation special, consequential or incidental damages. ON Semiconductor does not convey any license under its patent rights nor the rights of others.

MECHANICAL CASE OUTLINE

PACKAGE DIMENSIONS

ON Semiconductor®



TO-220, SINGLE GAUGE CASE 221AB-01 ISSUE A

DATE 16 NOV 2010

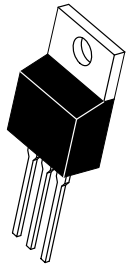

SCALE 1:1

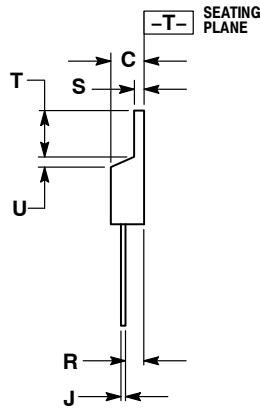
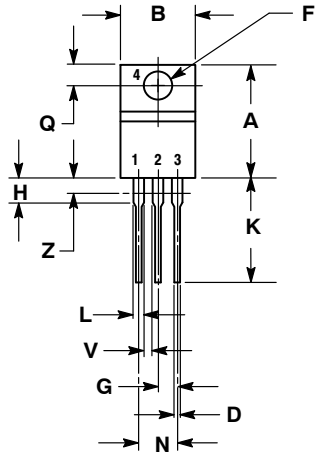

NOTES:

1. DIMENSIONING AND TOLERANCING PER ANSI Y14.5M, 1982.
2. CONTROLLING DIMENSION: INCHES.
3. DIMENSION Z DEFINES A ZONE WHERE ALL BODY AND LEAD IRREGULARITIES ARE ALLOWED.
4. PRODUCT SHIPPED PRIOR TO 2008 HAD DIMENSIONS S = 0.045 - 0.055 INCHES (1.143 - 1.397 MM)

DIM	INCHES		MILLIMETERS	
	MIN	MAX	MIN	MAX
A	0.570	0.620	14.48	15.75
B	0.380	0.405	9.66	10.28
C	0.160	0.190	4.07	4.82
D	0.025	0.035	0.64	0.88
F	0.142	0.147	3.61	3.73
G	0.095	0.105	2.42	2.66
H	0.110	0.155	2.80	3.93
J	0.018	0.025	0.46	0.64
K	0.500	0.562	12.70	14.27
L	0.045	0.060	1.15	1.52
N	0.190	0.210	4.83	5.33
Q	0.100	0.120	2.54	3.04
R	0.080	0.110	2.04	2.79
S	0.020	0.024	0.508	0.61
T	0.235	0.255	5.97	6.47
U	0.000	0.050	0.00	1.27
V	0.045	---	1.15	---
Z	---	0.080	---	2.04

STYLE 1:

- PIN 1. BASE
2. COLLECTOR
3. EMITTER
4. COLLECTOR

STYLE 2:

- PIN 1. BASE
2. EMITTER
3. COLLECTOR
4. EMITTER

STYLE 3:

- PIN 1. CATHODE
2. ANODE
3. GATE
4. ANODE

STYLE 4:

- PIN 1. MAIN TERMINAL 1
2. MAIN TERMINAL 2
3. GATE
4. MAIN TERMINAL 2

STYLE 5:

- PIN 1. GATE
2. DRAIN
3. SOURCE
4. DRAIN

STYLE 6:

- PIN 1. ANODE
2. CATHODE
3. ANODE
4. CATHODE

STYLE 7:

- PIN 1. CATHODE
2. ANODE
3. CATHODE
4. ANODE

STYLE 8:

- PIN 1. CATHODE
2. ANODE
3. EXTERNAL TRIP/DELAY
4. ANODE

STYLE 9:

- PIN 1. GATE
2. COLLECTOR
3. EMITTER
4. COLLECTOR

STYLE 10:

- PIN 1. GATE
2. SOURCE
3. DRAIN
4. SOURCE

STYLE 11:

- PIN 1. DRAIN
2. SOURCE
3. GATE
4. SOURCE

DOCUMENT NUMBER:	98AON23085D	Electronic versions are uncontrolled except when accessed directly from the Document Repository. Printed versions are uncontrolled except when stamped "CONTROLLED COPY" in red.
DESCRIPTION:	TO-220, SINGLE GAUGE	PAGE 1 OF 1

ON Semiconductor and are trademarks of Semiconductor Components Industries, LLC dba ON Semiconductor or its subsidiaries in the United States and/or other countries. ON Semiconductor reserves the right to make changes without further notice to any products herein. ON Semiconductor makes no warranty, representation or guarantee regarding the suitability of its products for any particular purpose, nor does ON Semiconductor assume any liability arising out of the application or use of any product or circuit, and specifically disclaims any and all liability, including without limitation special, consequential or incidental damages. ON Semiconductor does not convey any license under its patent rights nor the rights of others.

MECHANICAL CASE OUTLINE PACKAGE DIMENSIONS

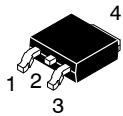

DPAK (SINGLE GAUGE) CASE 369C ISSUE G

DATE 31 MAY 2023

SCALE 1:1

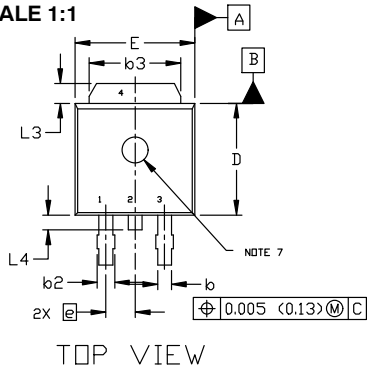

TOP VIEW

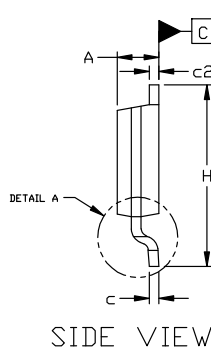

SIDE VIEW

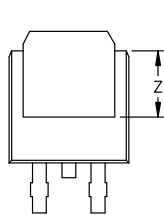

BOTTOM VIEW

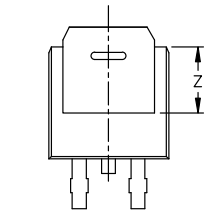
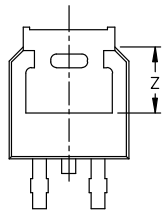

BOTTOM VIEW

ALTERNATE CONSTRUCTIONS

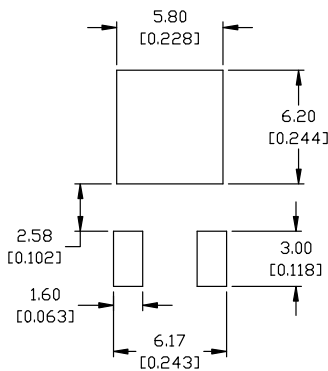

RECOMMENDED MOUNTING FOOTPRINT*

*FOR ADDITIONAL INFORMATION ON OUR Pb-FREE STRATEGY AND SOLDERING DETAILS, PLEASE DOWNLOAD THE ON SEMICONDUCTOR SOLDERING AND MOUNTING TECHNIQUES REFERENCE MANUAL, SOLDERM/D.

- | | | | | |
|--|--|---|---|--|
| <p>STYLE 1:
PIN 1. BASE
2. COLLECTOR
3. EMITTER
4. COLLECTOR</p> | <p>STYLE 2:
PIN 1. GATE
2. DRAIN
3. SOURCE
4. DRAIN</p> | <p>STYLE 3:
PIN 1. ANODE
2. CATHODE
3. ANODE
4. CATHODE</p> | <p>STYLE 4:
PIN 1. CATHODE
2. ANODE
3. GATE
4. ANODE</p> | <p>STYLE 5:
PIN 1. GATE
2. ANODE
3. CATHODE
4. ANODE</p> |
| <p>STYLE 6:
PIN 1. MT1
2. MT2
3. GATE
4. MT2</p> | <p>STYLE 7:
PIN 1. GATE
2. COLLECTOR
3. EMITTER
4. COLLECTOR</p> | <p>STYLE 8:
PIN 1. N/C
2. CATHODE
3. ANODE
4. CATHODE</p> | <p>STYLE 9:
PIN 1. ANODE
2. CATHODE
3. RESISTOR ADJUST
4. CATHODE</p> | <p>STYLE 10:
PIN 1. CATHODE
2. ANODE
3. CATHODE
4. ANODE</p> |

NOTES:

- DIMENSIONING AND TOLERANCING ASME Y14.5M, 1994.
- CONTROLLING DIMENSION: INCHES
- THERMAL PAD CONTOUR OPTIONAL WITHIN DIMENSIONS b3, L3, AND Z.
- DIMENSIONS D AND E DO NOT INCLUDE MOLD FLASH, PROTRUSIONS, OR BURRS. MOLD FLASH, PROTRUSIONS, OR GATE BURRS SHALL NOT EXCEED 0.006 INCHES PER SIDE.
- DIMENSIONS D AND E ARE DETERMINED AT THE OUTERMOST EXTREMES OF THE PLASTIC BODY.
- DATUMS A AND B ARE DETERMINED AT DATUM PLANE H.
- OPTIONAL MOLD FEATURE.

DIM	INCHES		MILLIMETERS	
	MIN.	MAX.	MIN.	MAX.
A	0.086	0.094	2.18	2.38
A1	0.000	0.005	0.00	0.13
b	0.025	0.035	0.63	0.89
b2	0.028	0.045	0.72	1.14
b3	0.180	0.215	4.57	5.46
c	0.018	0.024	0.46	0.61
c2	0.018	0.024	0.46	0.61
D	0.235	0.245	5.97	6.22
E	0.250	0.265	6.35	6.73
e	0.090	BSC	2.29	BSC
H	0.370	0.410	9.40	10.41
L	0.055	0.070	1.40	1.78
L1	0.114	REF	2.90	REF
L2	0.020	BSC	0.51	BSC
L3	0.035	0.050	0.89	1.27
L4	----	0.040	---	1.01
Z	0.155	----	3.93	---

GENERIC MARKING DIAGRAM*

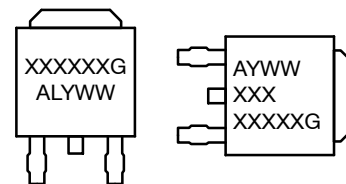

IC

Discrete

- XXXXXX = Device Code
- A = Assembly Location
- L = Wafer Lot
- Y = Year
- WW = Work Week
- G = Pb-Free Package

*This information is generic. Please refer to device data sheet for actual part marking. Pb-Free indicator, "G" or microdot "•", may or may not be present. Some products may not follow the Generic Marking.

DOCUMENT NUMBER:	98AON10527D	Electronic versions are uncontrolled except when accessed directly from the Document Repository. Printed versions are uncontrolled except when stamped "CONTROLLED COPY" in red.
DESCRIPTION:	DPAK (SINGLE GAUGE)	PAGE 1 OF 1

onsemi and Onsemi are trademarks of Semiconductor Components Industries, LLC dba onsemi or its subsidiaries in the United States and/or other countries. onsemi reserves the right to make changes without further notice to any products herein. onsemi makes no warranty, representation or guarantee regarding the suitability of its products for any particular purpose, nor does onsemi assume any liability arising out of the application or use of any product or circuit, and specifically disclaims any and all liability, including without limitation special, consequential or incidental damages. onsemi does not convey any license under its patent rights nor the rights of others.

onsemi, **Onsemi**, and other names, marks, and brands are registered and/or common law trademarks of Semiconductor Components Industries, LLC dba "**onsemi**" or its affiliates and/or subsidiaries in the United States and/or other countries. **onsemi** owns the rights to a number of patents, trademarks, copyrights, trade secrets, and other intellectual property. A listing of **onsemi**'s product/patent coverage may be accessed at www.onsemi.com/site/pdf/Patent-Marking.pdf. **onsemi** reserves the right to make changes at any time to any products or information herein, without notice. The information herein is provided "as-is" and **onsemi** makes no warranty, representation or guarantee regarding the accuracy of the information, product features, availability, functionality, or suitability of its products for any particular purpose, nor does **onsemi** assume any liability arising out of the application or use of any product or circuit, and specifically disclaims any and all liability, including without limitation special, consequential or incidental damages. Buyer is responsible for its products and applications using **onsemi** products, including compliance with all laws, regulations and safety requirements or standards, regardless of any support or applications information provided by **onsemi**. "Typical" parameters which may be provided in **onsemi** data sheets and/or specifications can and do vary in different applications and actual performance may vary over time. All operating parameters, including "Typicals" must be validated for each customer application by customer's technical experts. **onsemi** does not convey any license under any of its intellectual property rights nor the rights of others. **onsemi** products are not designed, intended, or authorized for use as a critical component in life support systems or any FDA Class 3 medical devices or medical devices with a same or similar classification in a foreign jurisdiction or any devices intended for implantation in the human body. Should Buyer purchase or use **onsemi** products for any such unintended or unauthorized application, Buyer shall indemnify and hold **onsemi** and its officers, employees, subsidiaries, affiliates, and distributors harmless against all claims, costs, damages, and expenses, and reasonable attorney fees arising out of, directly or indirectly, any claim of personal injury or death associated with such unintended or unauthorized use, even if such claim alleges that **onsemi** was negligent regarding the design or manufacture of the part. **onsemi** is an Equal Opportunity/Affirmative Action Employer. This literature is subject to all applicable copyright laws and is not for resale in any manner.

ADDITIONAL INFORMATION

TECHNICAL PUBLICATIONS:

Technical Library: www.onsemi.com/design/resources/technical-documentation
onsemi Website: www.onsemi.com

ONLINE SUPPORT: www.onsemi.com/support

For additional information, please contact your local Sales Representative at www.onsemi.com/support/sales

Looking for pricing, stock, or lifecycle information?

Click below to explore more details on WIN SOURCE:

 [View NCV317MABSTT3G on WIN SOURCE](#)

 [ON Semiconductor](#) Information

Optimize Your Supply Chain with WIN SOURCE Solutions

-  Global Sourcing Solution
-  Obsolete Management
-  Cost Control Management
-  Shortage Management
-  Alternative Solution
-  Excess Inventory Management