



**THE DATASHEET OF
CLC002MA**



CLC002 SMPTE 292M / 259M Serial Digital Cable Driver

Check for Samples: [CLC002](#)

FEATURES

- **SMPTE 292M, SMPTE 344M and SMPTE 259M Compliant**
- **Data Rates to 1.485 Gbps**
- **Differential Input**
- **75Ω Differential Output**
- **Selectable Slew Rate**
- **Adjustable Output Amplitude**
- **Single 3.3V Supply Operation**
- **Operating Temperature Range: Commercial 0°C to +70°C (CLC002MA) or Industrial –40°C to +85°C (CLC002TMA)**
- **Typical Power Consumption: 125mW in SD Mode and 149mW in HD Mode**
- **Replaces the GS1528 and GS1528A**

APPLICATIONS

- **SMPTE 292M, SMPTE 344M, and SMPTE 259M Serial Digital Interfaces**
- **Sonet/SDH and ATM Interfaces**
- **Digital Routers and Switches**
- **Distribution Amplifiers**
- **Buffer Applications**
- **Set Top Boxes**
- **Security Cameras**

DESCRIPTION

The CLC002 SMPTE 292M / 259M serial digital cable driver is a monolithic, high-speed cable driver designed for use in SMPTE 292M / 259M serial digital video and ITU-T G.703 serial digital data transmission applications. The CLC002 drives 75Ω transmission lines (Belden 8281, Belden 1694A or equivalent) at data rates up to 1.485 Gbps.

The CLC002 provides two selectable slew rates for SMPTE 259M and SMPTE 292M compliance. The output voltage swing is adjustable via a single external resistor.

The CLC002 is powered from a single 3.3V supply. Power consumption is typically 125mW in SD mode and 149mW in HD mode.



Please be aware that an important notice concerning availability, standard warranty, and use in critical applications of Texas Instruments semiconductor products and disclaimers thereto appears at the end of this data sheet.

All trademarks are the property of their respective owners.

TYPICAL APPLICATION

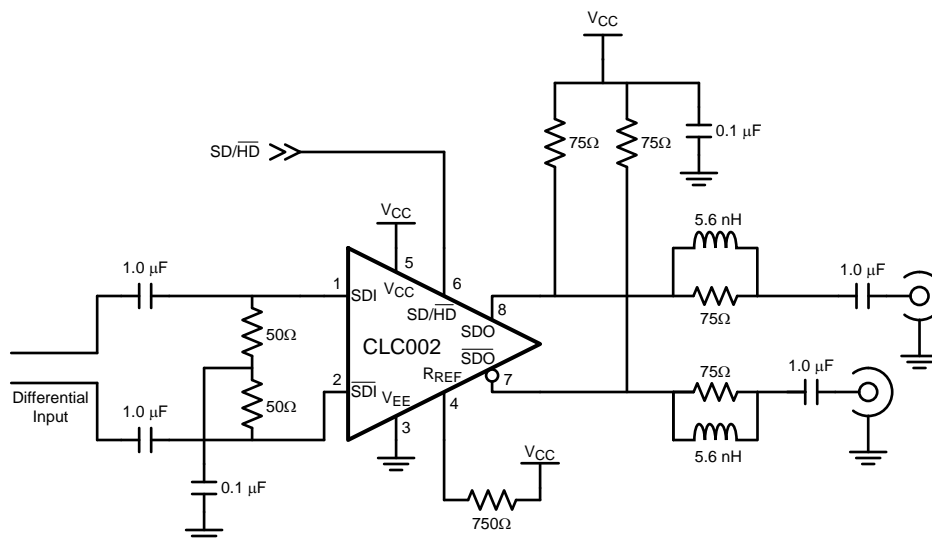

These devices have limited built-in ESD protection. The leads should be shorted together or the device placed in conductive foam during storage or handling to prevent electrostatic damage to the MOS gates.

ABSOLUTE MAXIMUM RATINGS ⁽¹⁾

Supply Voltage:		-0.5V to 3.6V
Input Voltage (all inputs)		-0.3V to $V_{CC}+0.3V$
Output Current		28mA
Storage Temperature Range		-65°C to +150°C
Junction Temperature		+150°C
Lead Temperature (Soldering 4 Sec)		+260°C
Package Thermal Resistance	θ_{JA} 8-pin SOIC	+125°C/W
	θ_{JC} 8-pin SOIC	+105°C/W
ESD Rating (HBM)		5kV
ESD Rating (MM)		250V

- (1) "Absolute Maximum Ratings" are those parameter values beyond which the life and operation of the device cannot be ensured. The stating herein of these maximums shall not be construed to imply that the device can or should be operated at or beyond these values. The table of "Electrical Characteristics" specifies acceptable device operating conditions.

RECOMMENDED OPERATING CONDITIONS

Supply Voltage ($V_{CC} - V_{EE}$):		3.3V $\pm 5\%$
Operating Free Air Temperature (T_A)	CLC002MA	0°C to +70°C
	CLC002TMA	-40°C to +85°C

DC ELECTRICAL CHARACTERISTICS

Over Supply Voltage and Operating Temperature ranges, unless otherwise specified ⁽¹⁾⁽²⁾.

Symbol	Parameter	Conditions	Reference	Min	Typ	Max	Units
$V_{C_{MIN}}$	Input Common Mode Voltage		SDI, \overline{SDI}	1.6 + $V_{SDI}/2$		$V_{CC} - V_{SDI}/2$	V
V_{SDI}	Input Voltage Swing	Differential		100		2000	mV _{P-P}

- (1) Current flow into device pins is defined as positive. Current flow out of device pins is defined as negative. All voltages are stated referenced to $V_{EE} = 0$ Volts.
 (2) Typical values are stated for $V_{CC} = +3.3V$ and $T_A = +25^\circ C$.

DC ELECTRICAL CHARACTERISTICS (continued)

Over Supply Voltage and Operating Temperature ranges, unless otherwise specified ⁽¹⁾⁽²⁾.

Symbol	Parameter	Conditions	Reference	Min	Typ	Max	Units
V _{CMOUT}	Output Common Mode Voltage		SDO, $\overline{\text{SDO}}$		$V_{CC} - V_{\text{SDO}}$		V
V _{SDO}	Output Voltage Swing	Single-ended, 75Ω load, R _{REF} = 750Ω 1%		750	800	850	mV _{P-P}
		Single-ended, 75Ω load, R _{REF} = 590Ω 1%		900	1000	1100	mV _{P-P}
	SD/ $\overline{\text{HD}}$ Input Voltage	Min for SD	SD/ $\overline{\text{HD}}$	2.4			V
		Max for HD				0.8	V
	SD/ $\overline{\text{HD}}$ Input Current			3.7			μA
I _{CC}	Supply Current	SD/ $\overline{\text{HD}}$ = 0, ⁽³⁾			45	49	mA
		SD/ $\overline{\text{HD}}$ = 1, ⁽³⁾			38	43	mA

(3) Maximum I_{CC} is measured at V_{CC} = +3.465V and T_A = +70°C.

AC ELECTRICAL CHARACTERISTICS

Over Supply Voltage and Operating Temperature ranges, unless otherwise specified ⁽¹⁾.

Symbol	Parameter	Conditions	Reference	Min	Typ	Max	Units
DR _{SDI}	Input Data Rate	See ⁽²⁾	SDI, $\overline{\text{SDI}}$			1485	Mbps
t _{jit}	Additive Jitter	1.485 Gbps	SDO, $\overline{\text{SDO}}$		26		pS _{P-P}
		270 Mbps			18		pS _{P-P}
t _r , t _f	Output Rise Time, Fall Time	SD/ $\overline{\text{HD}}$ = 0, 20% – 80%, ⁽³⁾			120	220	ps
		SD/ $\overline{\text{HD}}$ = 1, 20% – 80%		400	560	800	ps
	Mismatch in Rise/Fall Time	See ⁽²⁾				30	ps
t _{OS}	Output Overshoot	See ⁽²⁾				8	%
RL _{SDO}	Output Return Loss	⁽⁴⁾		15	20		dB

(1) Typical values are stated for V_{CC} = +3.3V and T_A = +25°C.

(2) Specification is ensured by characterization.

(3) Specification is ensure by characterization and verified by test.

(4) Output return loss is dependent on board design. The CLC002 meets this specification on the SD002 evaluation board from 5MHz to 1.5GHz.

CONNECTION DIAGRAM

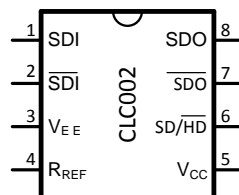

Figure 1. 8-Pin SOIC

PIN DESCRIPTIONS

Pin #	Name	Description
1	SDI	Serial data true input.
2	$\overline{\text{SDI}}$	Serial data complement input.
3	V _{EE}	Negative power supply (ground).
4	R _{REF}	Output driver level control. Connect a resistor to V _{CC} to set output voltage swing.
5	V _{CC}	Positive power supply (+3.3V).

PIN DESCRIPTIONS (continued)

Pin #	Name	Description
6	SD/HD	Output slew rate control. Output rise/fall time complies with SMPTE 292M when low and SMPTE 259M when high.
7	$\overline{\text{SDO}}$	Serial data complement output.
8	SDO	Serial data true output.

DEVICE OPERATION

INPUT INTERFACING

The CLC002 accepts either differential or single-ended input. The inputs are self-biased, allowing for simple AC or DC coupling. DC-coupled inputs must be kept within the specified common-mode range. SDI and $\overline{\text{SDI}}$ are self-biased at approximately 2.1V with $V_{CC} = 3.3\text{V}$. Figure 2 shows the differential input stage for SDI and $\overline{\text{SDI}}$.

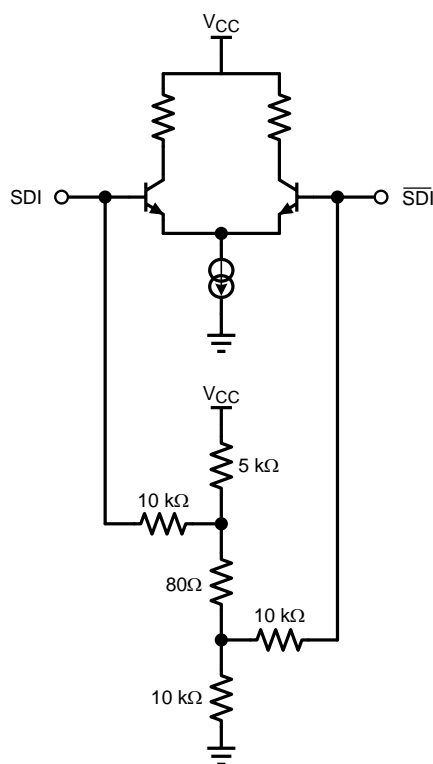

Figure 2. Differential Input Stage for SDI and $\overline{\text{SDI}}$.

OUTPUT INTERFACING

The CLC002 uses current mode outputs. Single-ended output levels are 800 mV_{P-P} into 75Ω AC-coupled coaxial cable (with $R_{REF} = 750\Omega$). Output level is controlled by the value of the R_{REF} resistor connected between pin 4 and V_{CC} .

The R_{REF} resistor should be placed as close as possible to the R_{REF} pin. In addition, the copper in the plane layers below the R_{REF} network should be removed to minimize parasitic capacitance.

OUTPUT SLEW RATE CONTROL

The CLC002 output rise and fall times are selectable for either SMPTE 259M or SMPTE 292M compliance via pin 6, SD/HD. For slower rise and fall times, or SMPTE 259M compliance, SD/HD is set high. For faster rise and fall times, or SMPTE 292M compliance, SD/HD is set low.

REPLACING THE GENNUM GS1528

The CLC002 is form-fit-function compatible with the Gennum GS1528 and GS1528A.

REVISION HISTORY

Changes from Revision F (April 2013) to Revision G

Page

-
- Changed layout of National Data Sheet to TI format [5](#)
-

IMPORTANT NOTICE

Texas Instruments Incorporated and its subsidiaries (TI) reserve the right to make corrections, enhancements, improvements and other changes to its semiconductor products and services per JESD46, latest issue, and to discontinue any product or service per JESD48, latest issue. Buyers should obtain the latest relevant information before placing orders and should verify that such information is current and complete. All semiconductor products (also referred to herein as "components") are sold subject to TI's terms and conditions of sale supplied at the time of order acknowledgment.

TI warrants performance of its components to the specifications applicable at the time of sale, in accordance with the warranty in TI's terms and conditions of sale of semiconductor products. Testing and other quality control techniques are used to the extent TI deems necessary to support this warranty. Except where mandated by applicable law, testing of all parameters of each component is not necessarily performed.

TI assumes no liability for applications assistance or the design of Buyers' products. Buyers are responsible for their products and applications using TI components. To minimize the risks associated with Buyers' products and applications, Buyers should provide adequate design and operating safeguards.

TI does not warrant or represent that any license, either express or implied, is granted under any patent right, copyright, mask work right, or other intellectual property right relating to any combination, machine, or process in which TI components or services are used. Information published by TI regarding third-party products or services does not constitute a license to use such products or services or a warranty or endorsement thereof. Use of such information may require a license from a third party under the patents or other intellectual property of the third party, or a license from TI under the patents or other intellectual property of TI.

Reproduction of significant portions of TI information in TI data books or data sheets is permissible only if reproduction is without alteration and is accompanied by all associated warranties, conditions, limitations, and notices. TI is not responsible or liable for such altered documentation. Information of third parties may be subject to additional restrictions.

Resale of TI components or services with statements different from or beyond the parameters stated by TI for that component or service voids all express and any implied warranties for the associated TI component or service and is an unfair and deceptive business practice. TI is not responsible or liable for any such statements.

Buyer acknowledges and agrees that it is solely responsible for compliance with all legal, regulatory and safety-related requirements concerning its products, and any use of TI components in its applications, notwithstanding any applications-related information or support that may be provided by TI. Buyer represents and agrees that it has all the necessary expertise to create and implement safeguards which anticipate dangerous consequences of failures, monitor failures and their consequences, lessen the likelihood of failures that might cause harm and take appropriate remedial actions. Buyer will fully indemnify TI and its representatives against any damages arising out of the use of any TI components in safety-critical applications.

In some cases, TI components may be promoted specifically to facilitate safety-related applications. With such components, TI's goal is to help enable customers to design and create their own end-product solutions that meet applicable functional safety standards and requirements. Nonetheless, such components are subject to these terms.

No TI components are authorized for use in FDA Class III (or similar life-critical medical equipment) unless authorized officers of the parties have executed a special agreement specifically governing such use.

Only those TI components which TI has specifically designated as military grade or "enhanced plastic" are designed and intended for use in military/aerospace applications or environments. Buyer acknowledges and agrees that any military or aerospace use of TI components which have **not** been so designated is solely at the Buyer's risk, and that Buyer is solely responsible for compliance with all legal and regulatory requirements in connection with such use.

TI has specifically designated certain components as meeting ISO/TS16949 requirements, mainly for automotive use. In any case of use of non-designated products, TI will not be responsible for any failure to meet ISO/TS16949.

Products

Audio	www.ti.com/audio
Amplifiers	amplifier.ti.com
Data Converters	dataconverter.ti.com
DLP® Products	www.dlp.com
DSP	dsp.ti.com
Clocks and Timers	www.ti.com/clocks
Interface	interface.ti.com
Logic	logic.ti.com
Power Mgmt	power.ti.com
Microcontrollers	microcontroller.ti.com
RFID	www.ti-rfid.com
OMAP Applications Processors	www.ti.com/omap
Wireless Connectivity	www.ti.com/wirelessconnectivity

Applications

Automotive and Transportation	www.ti.com/automotive
Communications and Telecom	www.ti.com/communications
Computers and Peripherals	www.ti.com/computers
Consumer Electronics	www.ti.com/consumer-apps
Energy and Lighting	www.ti.com/energy
Industrial	www.ti.com/industrial
Medical	www.ti.com/medical
Security	www.ti.com/security
Space, Avionics and Defense	www.ti.com/space-avionics-defense
Video and Imaging	www.ti.com/video

TI E2E Community

e2e.ti.com

Looking for pricing, stock, or lifecycle information?

Click below to explore more details on WIN SOURCE:

 [View CLC002MA](#) on WIN SOURCE

 [Texas Instruments](#) Information

Optimize Your Supply Chain with WIN SOURCE Solutions

-  Global Sourcing Solution
-  Obsolete Management
-  Cost Control Management
-  Shortage Management
-  Alternative Solution
-  Excess Inventory Management