



**THE DATASHEET OF
CLC006AJE/NOPB**



CLC006

Serial Digital Cable Driver with Adjustable Outputs

General Description

National's Comlinear CLC006 is a monolithic, high-speed cable driver designed for the SMPTE 259M serial digital video data transmission standard. The CLC006 drives 75Ω transmission lines (Belden 8281 or equivalent) at data rates up to 400 Mbps. Controlled output rise and fall times (650 ps typical) minimize transition-induced jitter. The output voltage swing, typically 1.65V, set by an accurate, low-drift internal bandgap reference, delivers an 800 mV swing to back-matched and terminated 75Ω cable. Output swing is adjustable from $0.7 V_{P-P}$ to $2 V_{P-P}$ using external resistors.

The CLC006's class AB output stage consumes less power than other designs, 185 mW with both outputs terminated, and requires no external bias resistors. The differential inputs accept a wide range of digital signals from 200 mV_{P-P} to ECL levels within the specified common-mode limits. All this make the CLC006 an excellent general purpose high speed driver for digital applications.

The CLC006 is powered from a single +5V or -5.2V supply and comes in an 8-pin SOIC package.

Key Specifications

- 650 ps rise and fall times
- Data rates to 400 Mbps
- 200 mV differential input
- Low residual jitter (25 ps_{pp})

Features

- No external pull-down resistors
- Adjustable output amplitude
- Differential input and output
- Low power dissipation
- Single +5V or -5.2V supply
- Replaces GS9008 in most applications

Applications

- Digital routers and distribution amplifiers
- Coaxial cable driver for digital transmission line
- Twisted pair driver
- Serial digital video interfaces for the commercial and broadcast industry
- SMPTE, Sonet/SDH, and ATM compatible driver
- Buffer applications

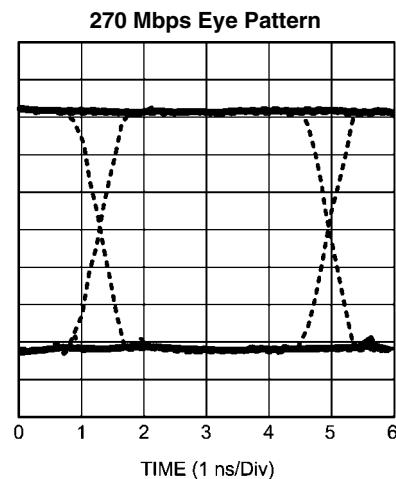

10008401

Connection Diagram (8-Pin SOIC)

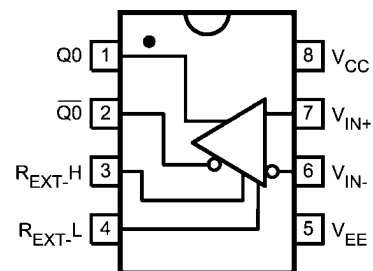

10008403

Order Number CLC006AJE
See NS Package Number M08A

Typical Application

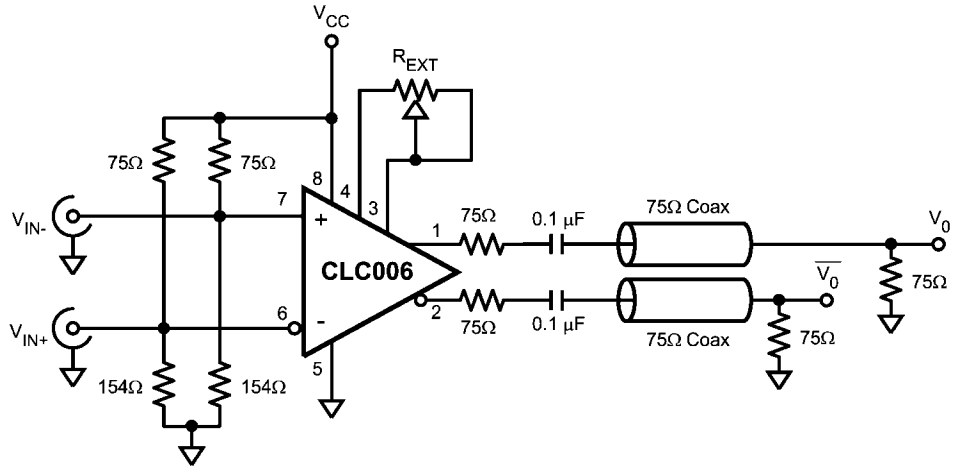

10008402

Absolute Maximum Ratings (Note 1)

If Military/Aerospace specified devices are required, please contact the National Semiconductor Sales Office/ Distributors for availability and specifications.

Supply Voltage	6V
Output Current	30 mA
Maximum Junction Temperature	+125°C
Storage Temperature Range	-65°C to +150°C
Lead Temperature (Soldering 10 Seconds)	+300°C

ESD Rating (Human Body Model)	1000V
Package Thermal Resistance	
θ_{JA} Surface Mount AJE	+160°C/W
θ_{JC} Surface Mount AJE	+105°C/W
Reliability Information MTTF	254 Mhr

Recommended Operating Conditions

Supply Voltage Range ($V_{CC} - V_{EE}$)	+4.5V to +5.5V
--	----------------

Electrical Characteristics

($V_{CC} = 0V$, $V_{EE} = -5V$; unless otherwise specified).

Parameter	Condition	Typ +25°C	Min/Max +25°C	Min/Max 0°C to +70°C	Min/Max -40°C to +85°C	Units
STATIC DC PERFORMANCE						
Supply Current, Loaded	150Ω @ 270 Mbps (Note 5)	37	—	—	—	mA
Supply Current, Unloaded	(Note 3)	34	28/45	26/47	26/47	mA
Output HIGH Voltage (V_{OH})	(Note 3)	-1.7	-2.0/1.4	-2.0/1.4	-2.0/1.4	V
Output LOW Voltage (V_{OL})	(Note 3)	-3.3	-3.6/3.0	-3.6/3.0	-3.6/3.0	V
Input Bias Current		10	30	50	50	μA
Output Swing	$R_{EXT} = \infty$ (Note 3)	1.65	1.55/1.75	1.53/1.77	1.51/1.79	V
Output Swing	$R_{EXT} = 10\text{ k}\Omega$	1.30	—	—	—	V
Common Mode Input Range Upper Limit		-0.7	-0.8	-0.8	-0.8	V
Common Mode Input Range Lower Limit		-2.6	-2.5	-2.5	-2.5	V
Minimum Differential Input Swing		200	200	200	200	mV
Power Supply Rejection Ratio (Note 3)		26	20	20	20	dB
AC PERFORMANCE						
Output Rise and Fall Time	(Notes 3, 4, 5)	650	425/825	400/850	400/850	ps
Overshoot		5				%
Propagation Delay		1.0				ns
Duty Cycle Distortion		50				ps
Residual Jitter		25	—	—	—	ps _{pp}
MISCELLANEOUS PERFORMANCE						
Input Capacitance		1.0				pF
Output Resistance		10				Ω
Output Inductance		6				nH

Note 1: "Absolute Maximum Ratings" are those values beyond which the safety of the device cannot be guaranteed. They are not meant to imply that the devices should be operated at these limits. The table of "Electrical Characteristics" specifies conditions of device operation.

Note 2: Min/Max ratings are based on product characterization and simulation. Individual parameters are tested as noted. Outgoing quality levels are determined from tested parameters.

Note 3: Spec is 100% tested at +25°C

Note 4: Measured between the 20% and 80% levels of the waveform.

Note 5: Measured with both outputs driving 150Ω, AC coupled at 270 Mbps.

Operation

INPUT INTERFACING

The CLC006 has high impedance, emitter-follower buffered, differential inputs. Single-ended signals may also be input. Transmission lines supplying input signals must be properly terminated close to the CLC006. Either A.C. or D.C. coupling as in *Figure 2* or *Figure 3* may be used. *Figures 2, 4* and *Figure 5* show how Thevenin-equivalent resistor networks are used

to provide input termination and biasing. The input D.C. common-mode voltage range is 0.8V to 2.5V below the positive supply (V_{CC}). Input signals plus bias should be kept within the specified common-mode range. For an 800 mV_{P-P} input signal, typical input bias levels range from 1.2V to 2.1V below the positive supply.

Load Type	Resistor to V_{CC} (R1)	Resistor to V_{EE} (R2)
ECL, 50Ω, 5V, $V_T=2V$	82.5Ω	124Ω
ECL, 50Ω, 5.2V, $V_T=2V$	80.6Ω	133Ω
ECL, 75Ω, 5V, $V_T=2V$	124Ω	187Ω
ECL, 75Ω, 5.2V, $V_T=2V$	121Ω	196Ω
800 mV _{P-P} , 50Ω, 5V, $V_T=1.6V$	75.0Ω	154Ω
800 mV _{P-P} , 75Ω, 5V, $V_T=1.6V$	110Ω	232Ω
800 mV _{P-P} , 2.2KΩ, 5Ω, $V_T=1.6V$	3240Ω	6810Ω

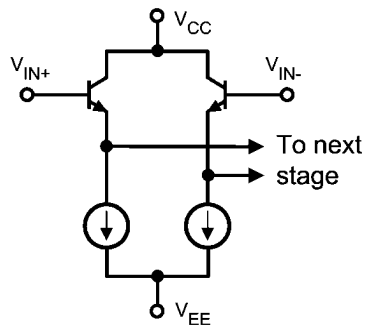

10008404

FIGURE 1. Input Stage

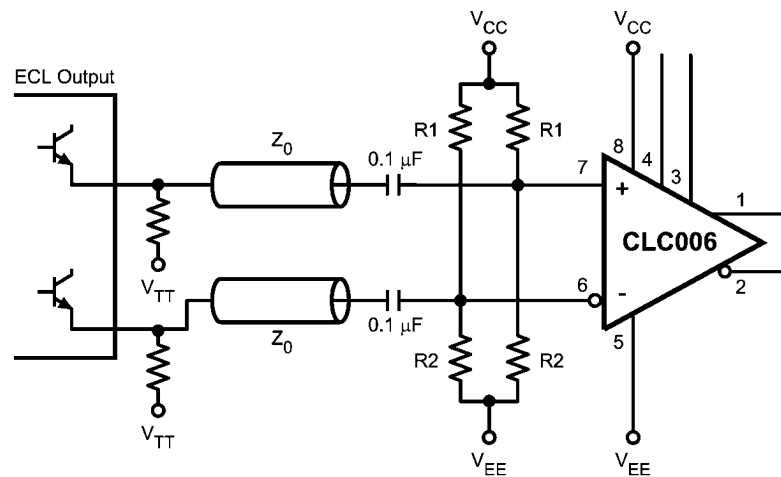

10008405

FIGURE 2. AC Coupled Input

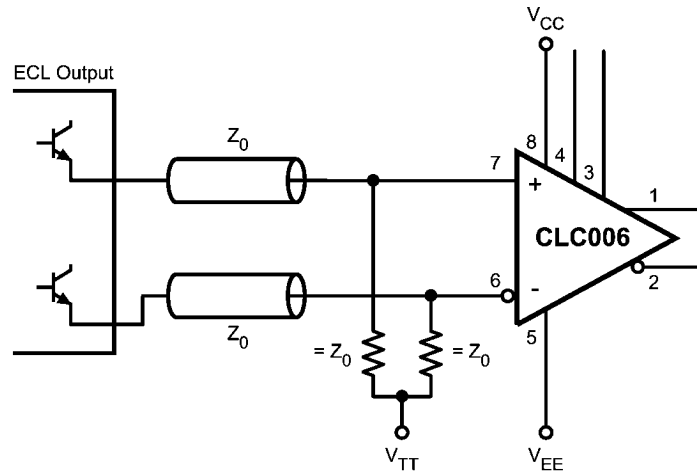

10008406

FIGURE 3. DC Coupled Input

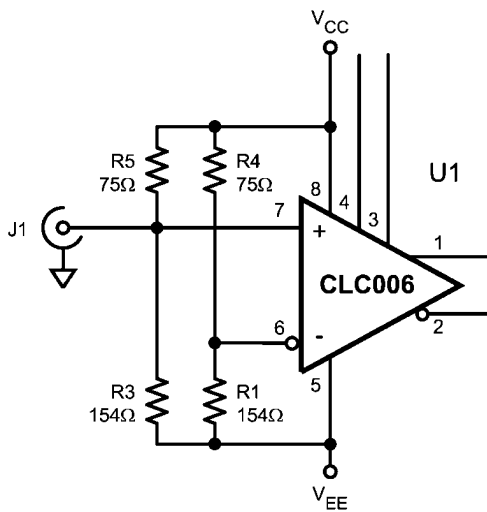

10008407

FIGURE 4. Single Ended 50Ω ECL input

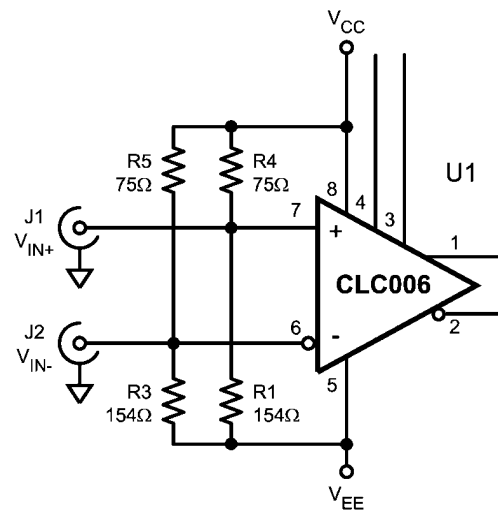

10008408

FIGURE 5. Differential 50Ω ECL Input

OUTPUT INTERFACING

The CLC006's class AB output stage, *Figure 6*, requires no standing current in the output transistors and therefore requires no biasing or pull-down resistors. Advantages of this arrangement are lower power dissipation and fewer external components. The output may be either D.C. or A.C. coupled to the load. A bandgap voltage reference sets output voltage

levels which are compatible with F100K and 10K ECL when correctly terminated. The outputs do not have the same output voltage temperature coefficient as 10K. Therefore, noise margins will be reduced over the full temperature range when driving 10K ECL. Noise margins will not be affected when interfacing to F100K since F100K is fully voltage and temperature compensated.

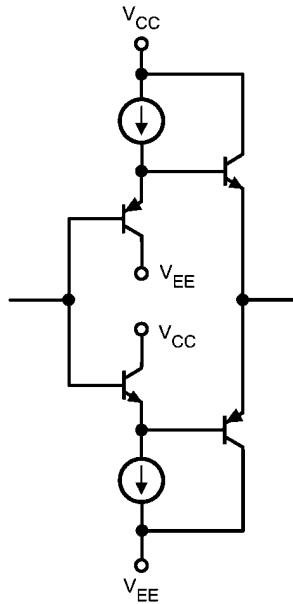

10008409

FIGURE 6. Output Stage

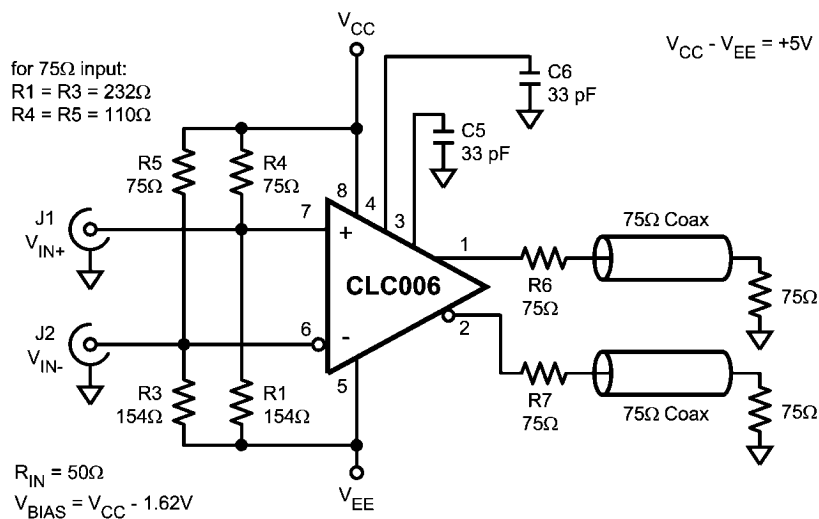

10008410

FIGURE 7. Differential Input DC Coupled Output

OUTPUT AMPLITUDE ADJUSTMENT

The high and low output levels of the CLC006 are set by a circuit shown simplified in *Figure 8*. Output high and low levels may be set independently with external resistor networks connected between R_{EXT-H} (pin 3), R_{EXT-L} (pin 4) and the power supplies. The resistor networks affect the high and low output levels by changing the internally generated bias voltages, V_H and V_L . The nominal high and low output levels are $V_{CC}-1.7V$ and $V_{CC}-3.3V$, respectively, when the pins R_{EXT-H} and R_{EXT-L} are left unconnected. Though the internal components which determine output voltage levels have accurate ratios, their absolute values may be controlled only within about $\pm 15\%$ of nominal. Even so, without external adjustment,

output voltages are well controlled. A final design should accommodate the variation in externally set output voltages due to the CLC006's part-to-part and external component tolerances.

Output voltage swing may be reduced with the circuit shown in *Figure 9*. A single resistance chosen with the aid of the graph, *Figure 10*, is connected between pins 3 and 4. Output voltage swing may be increased with the circuit of *Figure 11*. *Figure 12* is used to estimate a value for resistor R. Note that both of these circuits and the accompanying graphs assume that the CLC006 is loaded with the standard 150Ω . Be aware

that output loading will affect the output swing and the high and low levels. It may be necessary to empirically select re-

sistances used to set output levels when the D.C. loading on the CLC006 differs appreciably from 150Ω.

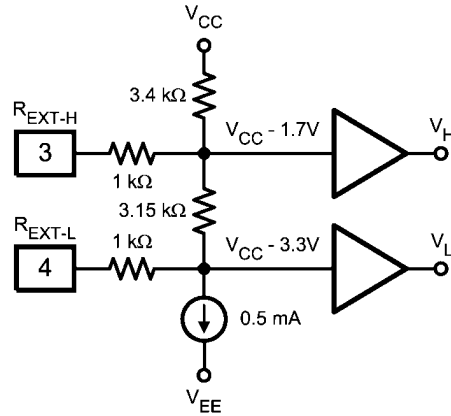

10008411

FIGURE 8. Equivalent Bias Generation Circuit

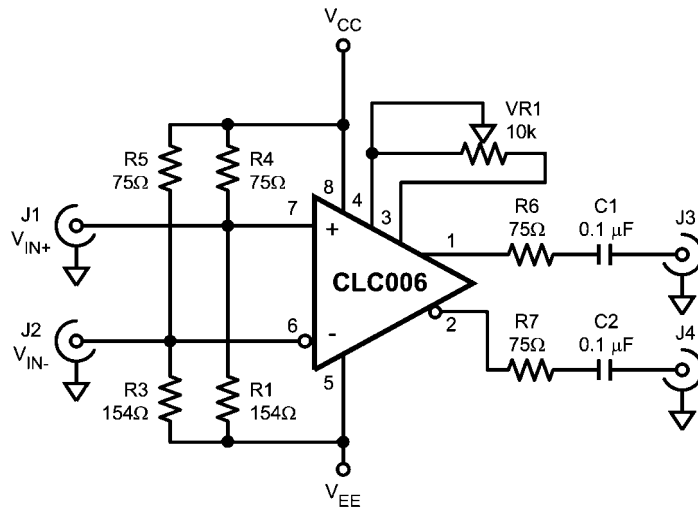

10008412

FIGURE 9. Differential Input Reduced Output

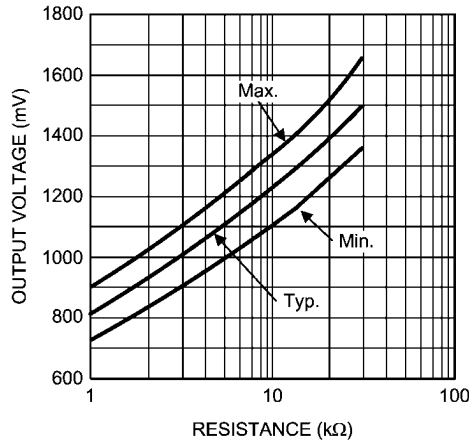

10008413

FIGURE 10. Resistance Pins 3 to 4 vs Output Voltage Reduced Output @ 150Ω Load

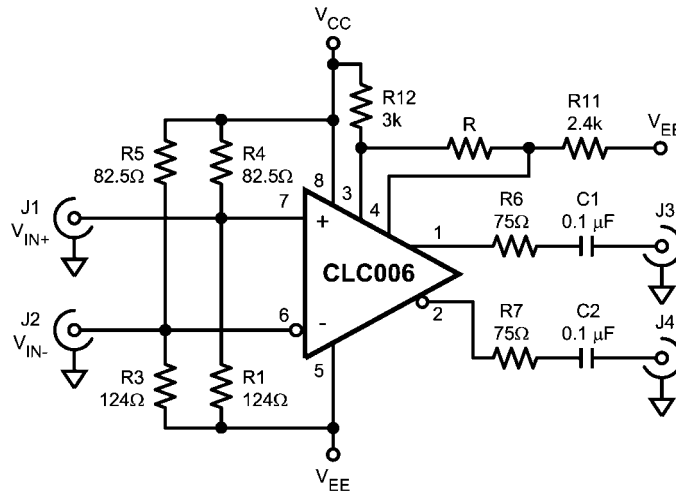

10008414

FIGURE 11. Differential Input Increased Output

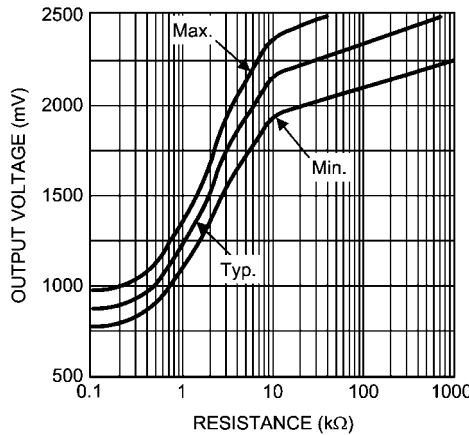

10008415

FIGURE 12. Resistance Pins 3 to 4 vs Output Voltage Increased Output @ 150Ω Load

OUTPUT RISE AND FALL TIMES

Output load capacitance can significantly affect output rise and fall times. The effect of load capacitance, stray or otherwise, may be reduced by placing the output back-match resistor close to the output pin and by minimizing all interconnecting trace lengths. *Figure 13* shows the effect on risetime of parallel load capacitance across a 150Ω load.

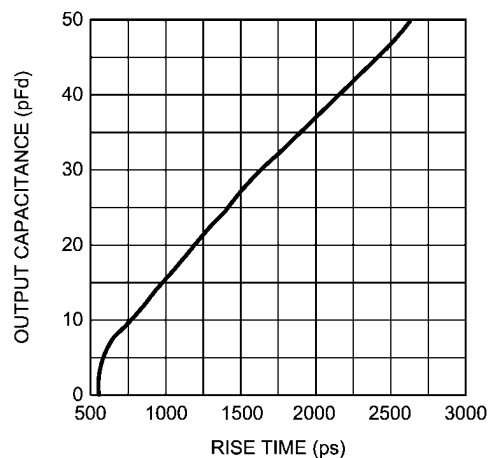

10008416

FIGURE 13. Rise Time vs C_L

PCB Layout Recommendations

Printed circuit board layout affects the performance of the CLC006. The following guidelines will aid in achieving satisfactory device performance.

- Use a ground plane or power/ground plane sandwich design for optimum performance.
- Bypass device power with a 0.01 μF monolithic ceramic capacitor in parallel with a 6.8 μF tantalum electrolytic capacitor located no more than 0.1" (2.5 mm) from the device power pins.
- Provide short, symmetrical ground return paths for:
 - inputs,
 - supply bypass capacitors and
 - the output load.
- Provide short, grounded guard traces located
 - under the centerline of the package,
 - 0.1" (2.5 mm) from the package pins
 - on both top and bottom of the board with connecting vias.

Physical Dimensions inches (millimeters) unless otherwise noted

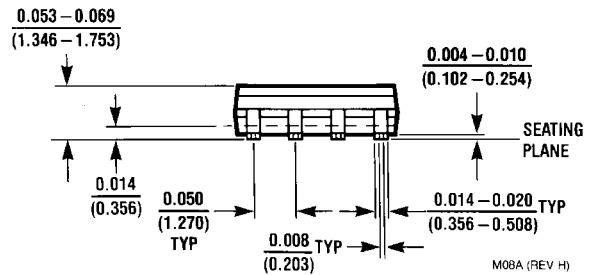
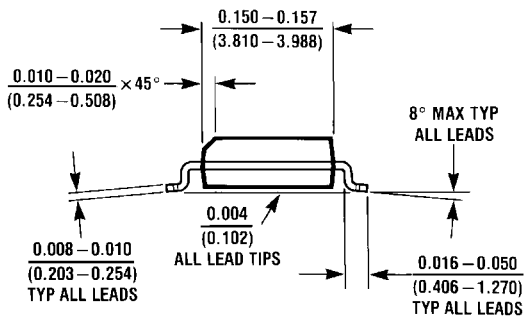
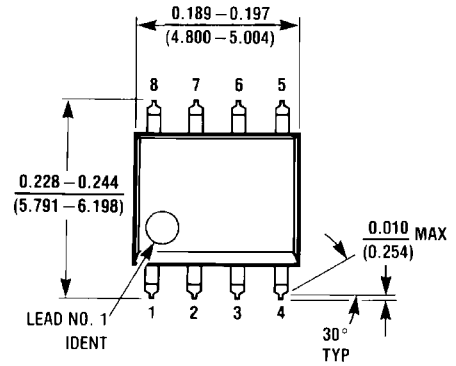

Order Number CLC006AJE
NS Package Number M08A

M08A (REV H)

Notes

CLC006

Notes

THE CONTENTS OF THIS DOCUMENT ARE PROVIDED IN CONNECTION WITH NATIONAL SEMICONDUCTOR CORPORATION ("NATIONAL") PRODUCTS. NATIONAL MAKES NO REPRESENTATIONS OR WARRANTIES WITH RESPECT TO THE ACCURACY OR COMPLETENESS OF THE CONTENTS OF THIS PUBLICATION AND RESERVES THE RIGHT TO MAKE CHANGES TO SPECIFICATIONS AND PRODUCT DESCRIPTIONS AT ANY TIME WITHOUT NOTICE. NO LICENSE, WHETHER EXPRESS, IMPLIED, ARISING BY ESTOPPEL OR OTHERWISE, TO ANY INTELLECTUAL PROPERTY RIGHTS IS GRANTED BY THIS DOCUMENT.

TESTING AND OTHER QUALITY CONTROLS ARE USED TO THE EXTENT NATIONAL DEEMS NECESSARY TO SUPPORT NATIONAL'S PRODUCT WARRANTY. EXCEPT WHERE MANDATED BY GOVERNMENT REQUIREMENTS, TESTING OF ALL PARAMETERS OF EACH PRODUCT IS NOT NECESSARILY PERFORMED. NATIONAL ASSUMES NO LIABILITY FOR APPLICATIONS ASSISTANCE OR BUYER PRODUCT DESIGN. BUYERS ARE RESPONSIBLE FOR THEIR PRODUCTS AND APPLICATIONS USING NATIONAL COMPONENTS. PRIOR TO USING OR DISTRIBUTING ANY PRODUCTS THAT INCLUDE NATIONAL COMPONENTS, BUYERS SHOULD PROVIDE ADEQUATE DESIGN, TESTING AND OPERATING SAFEGUARDS.

EXCEPT AS PROVIDED IN NATIONAL'S TERMS AND CONDITIONS OF SALE FOR SUCH PRODUCTS, NATIONAL ASSUMES NO LIABILITY WHATSOEVER, AND NATIONAL DISCLAIMS ANY EXPRESS OR IMPLIED WARRANTY RELATING TO THE SALE AND/OR USE OF NATIONAL PRODUCTS INCLUDING LIABILITY OR WARRANTIES RELATING TO FITNESS FOR A PARTICULAR PURPOSE, MERCHANTABILITY, OR INFRINGEMENT OF ANY PATENT, COPYRIGHT OR OTHER INTELLECTUAL PROPERTY RIGHT.

LIFE SUPPORT POLICY

NATIONAL'S PRODUCTS ARE NOT AUTHORIZED FOR USE AS CRITICAL COMPONENTS IN LIFE SUPPORT DEVICES OR SYSTEMS WITHOUT THE EXPRESS PRIOR WRITTEN APPROVAL OF THE CHIEF EXECUTIVE OFFICER AND GENERAL COUNSEL OF NATIONAL SEMICONDUCTOR CORPORATION. As used herein:

Life support devices or systems are devices which (a) are intended for surgical implant into the body, or (b) support or sustain life and whose failure to perform when properly used in accordance with instructions for use provided in the labeling can be reasonably expected to result in a significant injury to the user. A critical component is any component in a life support device or system whose failure to perform can be reasonably expected to cause the failure of the life support device or system or to affect its safety or effectiveness.

National Semiconductor and the National Semiconductor logo are registered trademarks of National Semiconductor Corporation. All other brand or product names may be trademarks or registered trademarks of their respective holders.

Copyright© 2007 National Semiconductor Corporation

For the most current product information visit us at www.national.com



National Semiconductor Americas Customer Support Center
 Email: new.feedback@nsc.com
 Tel: 1-800-272-9959

National Semiconductor Europe Customer Support Center
 Fax: +49 (0) 180-530-85-86
 Email: europe.support@nsc.com
 Deutsch Tel: +49 (0) 69 9508 6208
 English Tel: +49 (0) 870 24 0 2171
 Français Tel: +33 (0) 1 41 91 8790

National Semiconductor Asia Pacific Customer Support Center
 Email: ap.support@nsc.com

National Semiconductor Japan Customer Support Center
 Fax: 81-3-5639-7507
 Email: jpn.feedback@nsc.com
 Tel: 81-3-5639-7560

Looking for pricing, stock, or lifecycle information?

Click below to explore more details on WIN SOURCE:

- ⊖ [View CLC006AJE/NOPB on WIN SOURCE](#)
- ⊖ [Texas Instruments Information](#)

Optimize Your Supply Chain with WIN SOURCE Solutions

- ✓ Global Sourcing Solution
- ✓ Obsolete Management
- ✓ Cost Control Management
- ✓ Shortage Management
- ✓ Alternative Solution
- ✓ Excess Inventory Management