



**THE DATASHEET OF
DLP3010EVM-LC**



DLP3010 Light Control EVM User's Guide

This user's guide presents an overview of the DLP3010 Light Control evaluation module (EVM) and a general description of the main features and functions. It explains the first steps to get started, and shows a detailed description of the push buttons function, the on board LEDs, and the main connectors.

Contents

1	DLP3010 Light Control EVM Overview	2
2	Safety Instructions	3
3	Applicable Documents	3
4	What is in the DLP3010 Light Control EVM?	4
5	Light Engine	5
6	Quick-Start Procedure.....	5
7	Circuit Description	7
8	EVM Setup.....	9

List of Figures

1	DLP3010 Light Control Complete EVM.....	2
2	DLP3010 Light Control EVM Block Diagram	4
3	DLP3010 Light Control EVM Optical Engine.....	5
4	Optical Engine with Focus Adjustment.....	6
5	DLP3010 Light Control Main Board	9
6	DLP3010 Light Control Connections	10
7	LED Connection	10
8	DLP3010 Light Control Complete EVM	11

List of Tables

1	Optical Engine Specifications	5
2	LEDs on the DLP3010 Light Control EVM	6
3	Installed Connectors on Main Board	7
4	Installed Push Buttons and Switch on Main Board	7
5	Installed Connectors on the DLP3010 Light Control Display Board	7
6	DLP3010 Light Control Trigger Description	8

1 DLP3010 Light Control EVM Overview

This DLP3010 Light Control EVM includes an example light engine design composing of DLP electronics and optics along with GUI software to provide a flexible light steering solution with high brightness and resolution for industrial, medical and scientific applications. This EVM features DLP3010, DLPC3478 and DLPA2005 DLP components and offers a compelling combination of resolution, brightness, and programmability in a small form factor.

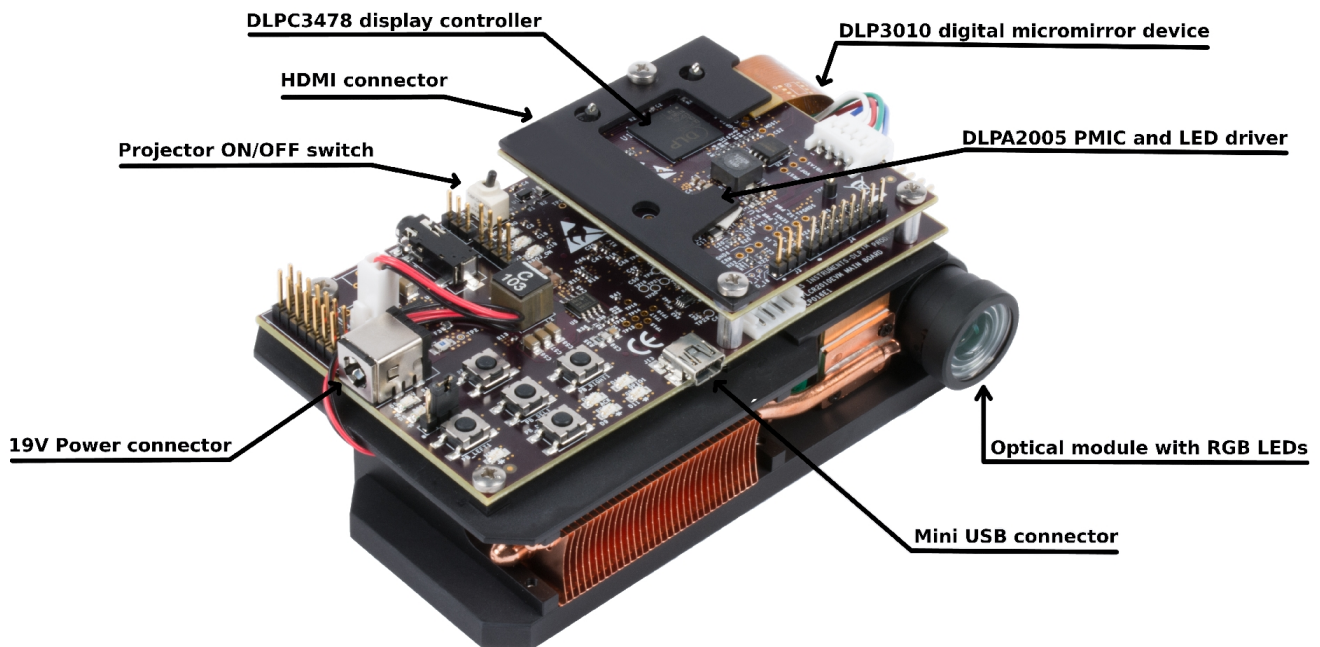

Figure 1. DLP3010 Light Control Complete EVM

In addition to this document, use documents listed in [Section 3](#).

2 Safety Instructions

CAUTION



Caution hot surface. Contact may cause burns. Do not touch.

WARNING

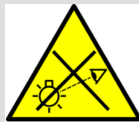

Possible hazardous optical radiation emitted from this EVM. Do not stare at the operating lamp. There are no user serviceable parts inside the EVM optical engine. Never open the optical engine, which can expose a risk group 2 LED which may be harmful to the eye.

WARNING



Observe handling precautions. Electrostatic sensitive devices.

WARNING

Always ensure both fans are running during operation to avoid overheating and ensure reliable operation.

3 Applicable Documents

The following documents are applicable to the DLP3010 Light Control EVM and are available at TI.com (www.ti.com).

- DLP3010 (0.3 720p) DMD data sheet ([DLPS051](#))
- DLPC3478 Display and Light Controller data sheet ([DLPS111](#))
- DLP Display and Light Control EVM GUI Tool User's Guide ([DLPU074](#))

If you need assistance, refer to the [DLP and MEMS TI E2E community support forums](#).

4 What is in the DLP3010 Light Control EVM?

The DLP3010 Light Control module consists of three subsystems:

- Light engine – includes the optics, red, green, and blue LEDs, and a 1280 × 720 (720p) DMD
- Driver board – includes the DLP chipset comprising of the DLPC3478 controller and DLPA2005 PMIC/LED driver. Includes a header to access Trigger IN/OUT signals for camera capture and other system controls
- System board – includes the MSP430, the ITE HDMI receiver, the USB-Serial Bridge controller, and several connectors for external inputs (HDMI, USB, etc.)

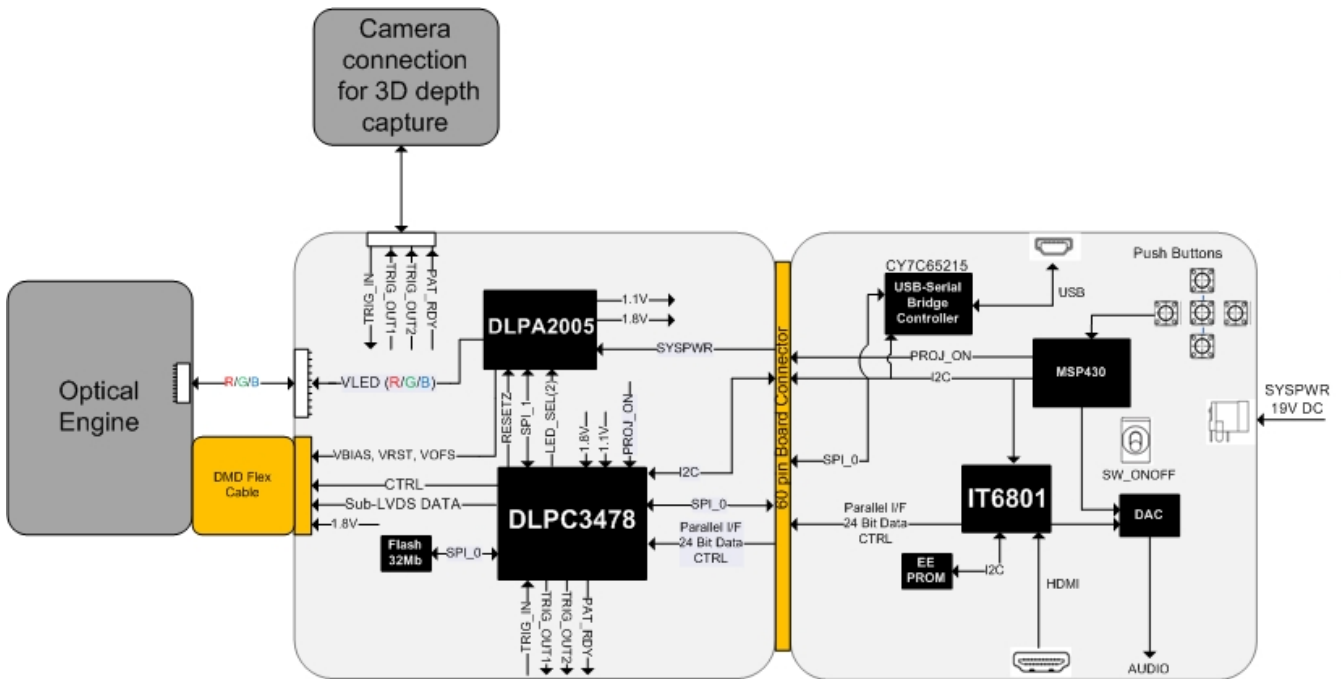

Figure 2. DLP3010 Light Control EVM Block Diagram

5 Light Engine

The optical engine, Model H6 is developed and manufactured by Shenzhenby Anhua Optoelectronics Technology Co., Ltd. and is production ready.

The light engine consists of the following components:

- 0.3-inch 720p DMD (DLP3010)
- OSRAM red, green, and blue LED

This light engine interfaces with the EVM using DMD pin mapping **Option 1**. Refer to the [DLPC3478](#) datasheet for more information about the DMD interface.

Table 1. Optical Engine Specifications

PARAMETER	MIN	TYP	MAX	UNIT
Brightness		125		Lum
LED Current		2.4		A
Brightness Uniformity	75%			
Throw Ratio		1.2		
Offset		100%		
Optics F-number		F/1.7		

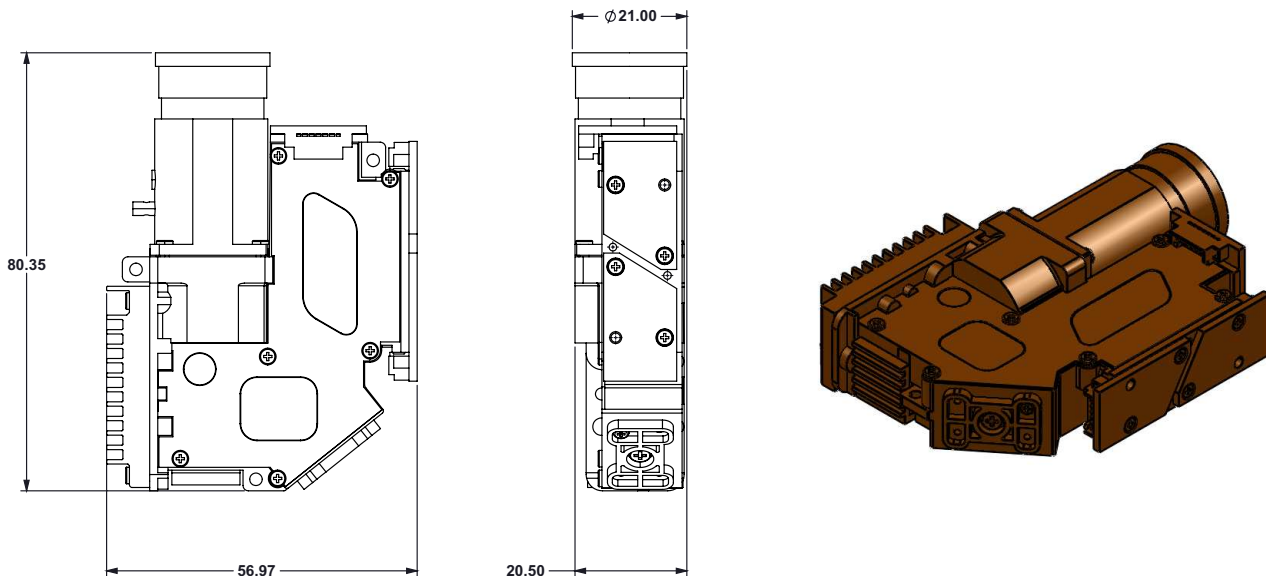

Figure 3. DLP3010 Light Control EVM Optical Engine

6 Quick-Start Procedure

This quick-start assumes default conditions as shipped.

1. Power up the DLP3010 Light Control EVM by applying an external DC power supply (19-V DC, 3.42 A) to the J10 connector. The P5V_VIN (D5) and P3P3V_SB (D6) LED will turn on to indicate that 5-V and 3.3-V standby power is applied.

External Power Supply Requirements:

- Nominal output voltage: 19-V DC
- Minimum output current: 3A; Max output current: 3.42 A
- Efficiency level: VI

NOTE: TI recommends using an external power supply that complies with applicable regional safety standards such as UL, CSA, VDE, CCC, PSE, etc. A DC Power Connector 2.5mm x 5.5mm is being used on the DLP3010 Light Control EVM Main Board.

NOTE: The system is designed to operate also with an external 12-V DC power supply.

2. Move the SW_ONOFF switch to the ON position to turn the DLP3010 Light Control EVM on. When the DLP3010 Light Control EVM is turned on, the PROJ_ON LED D3 will turn on.
3. After the DLP3010 Light Control EVM is turned on; the projector will default to displaying a DLP Light Control splash image.
4. The focus of the image can be adjusted on the optical engine.

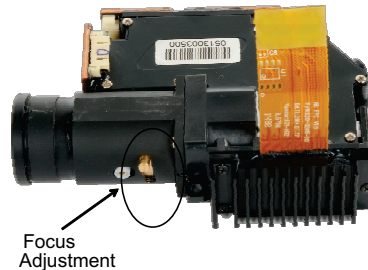

Figure 4. Optical Engine with Focus Adjustment

5. Connect USB to the DLP3010 Light Control EVM and open the DLP3010 Display and Light Control Graphical User Interface (GUI) on your computer. If needed, connect an HDMI source to the EVM and communicate to the EVM over the GUI software.
6. Via the GUI the EVM can be set to Video Display Mode or Light Control Modes. Refer to the GUI user's guide for further description. Note: Install Jumper J11 on the DLP3010 Light Control EVM Main Board to set Trigger IN/OUT voltage on the EVM. This jumper is required to gain access to the trigger signals. The jumper is not included by default.
7. When turning off the projector, turn off the SW_ONOFF switch prior to removing power cable. Note: To avoid potential damage to the DMD, it is recommended to turn off the projector with SW_ONOFF before disconnecting the power.

There are ten indicator LEDs on the DLP3010 Light Control EVM, and they are defined in [Table 2](#):

Table 2. LEDs on the DLP3010 Light Control EVM

LED REFERENCE	SIGNAL INDICATION	DESCRIPTION
D1	HOST_IRQ	ON during DLPC3478 boot OFF when projector is running. Indication of DLPC3478 boot-up completed and ready to receive commands
D2	RESETZ	OFF when projector is turned on via SW_ONOFF
D3	PROJ_ON	On when projector is turned on via SW_ONOFF
D5	P5V_VIN	5-V power applied
D6	P3P3V_SB	Regulated 3V3 power on
D7	MSP2	ON when HDMI cable plugged in and external video detected. OFF when external video is not detected.
D8	ACK	ON when Cypress CY3420 is I ² C master OFF when MSP430 is I ² C master
D9	REQ	ON when Cypress CY3420 requests the MSP430 to give Cypress master control of the I ² C bus
D10	GPIO1	Blinking when PC is communicating to flash over SPI
D11	GPIO0	Blinking when PC is communicating to DLPC3478 over I ² C

7 Circuit Description

7.1 Connectors, Switch, and Push Buttons on Main Board

Table 3. Installed Connectors on Main Board

INSTALLED CONNECTORS/HEADERS	DESCRIPTION
J1	MSP430 JTAG programming interface connector
J2	Header for 5-V DC power (not installed by default)
J3	Connector for audio
J4	Unsupported
J5	Header for EDID programming
J6	Connector for HDMI input
J7	Header for 5-V DC power used for fan connection
J8	Unsupported
J9	60-pin connector for DLP Light Control Display board
J10	Connector for 19-V external power supply interface
J11	Header for voltage level selection for Trigger-in/out (Install jumper to receive output signal this is not included with the EVM)
J12	Header for remaining DLPC3478 test points (not installed by default)
J13	Connector for Mini-USB cable
J14	Connector for the I ² C interface (DevaSys box) (not installed by default)

Table 4. Installed Push Buttons and Switch on Main Board

INSTALLED SWITCHES/PUSH BUTTONS	DESCRIPTION
SW1	Projector ON/OFF switch
PB-UP1	Source selection <ul style="list-style-type: none"> • First press: TPG • Second press: HDMI input • Third press: Splash screen
PB-SEL1	Cycle through displaying 7 curtain colors
PB-DOWN1	Flip image N/S or E/W
PB_LEFT1	Cycle 9 different TPG patterns after TPG source selected Cycle 4 different splash screens after splash source selected Change of volume when HDMI input is selected
PB_RIGHT1	Change LED current total 7 steps Change of volume when HDMI input is selected

7.2 Connectors on DLP3010 Light Control Display Board

Table 5. Installed Connectors on the DLP3010 Light Control Display Board

INSTALLED CONNECTORS/HEADERS	DESCRIPTION
J1	Connector for the DMD flex cable
J2	Connector for LED cable
J3	Connector for selecting 3DR signal usage (Display or Light Control)
J4	Connector for Trigger-in and Triger-out for Light Control Application
J5	60-pin connector for DLP Light Control Display board

7.3 DLP3010 Light Control Trigger Description

Table 6. DLP3010 Light Control Trigger Description ⁽¹⁾

DLPC3478 PIN	J4 PIN CONNECTOR		I/O	FUNCTION
	NO.	DESC		
3DR	5	3DR_BF	Input	For light control applications: Reserved for external trigger signal (Input). Applicable to Internal Pattern Streaming Mode only. The 3DR pin on the DLPC3478 can be used as a 3D left or right reference indicator or as trigger input signal for light control application. A jumper on J3 has to be installed to determine the use case for this pin. For display application: Connect pin 1 and pin 2 of J3. For light control application: Connect pin 2 and pin 3 of J3.
TSTPT_4 ⁽²⁾	7	TSTPT_4_BF	Output	TRIG_OUT_1 signal.
GPIO_06	3	GPIO_6_BF	Output	Pattern Ready signal. Applicable to Internal Pattern Streaming Mode only.
GPIO_07	4	GPIO_7_BF	Output	TRIG_OUT_2 signal.

⁽¹⁾ Install Jumper J11 to set Trigger IN/OUT voltage on the EVM (Jumper is not included by default). For 3.3-V signal level: Connect pin 2 and p 3 of J11. For 1.8-V signal level : Connect pin 1 and pin 2 of J11.

⁽²⁾ See IMPORTANT note below.

IMPORTANT:

The Rev A Display Boards use a level shifter which changes the incoming signal level to 1.8 V. The correct voltage level for the DLP controller is 3.3 V. If EVM does not detect the input signal correctly, modify the placement of resistors R32 and R35.

- Rotate R35 to disconnect pull-up resistor from the 1.8-V supply.
 - Connect free end of R35 to 3.3 V. The 3.3-V connection at R32 can be used.
-

8 EVM Setup

The DLP3010 Light Control EVM is composed of three parts:

- DLP3010 Light Control main board
- DLP3010 Light Control display board
- Engine with LED connection and flex cable

The main board contains the connector for the power supply, a USB connector to communicate to the DLP3010 Light Control GUI, HDMI, audio, and the connector for the DLP3010 Light Control display board. The main board also contains a switch to turn on the projector in case the DLP3010 Light Control display board and the engine are connected. [Figure 5](#) shows the main connectors on the main board.

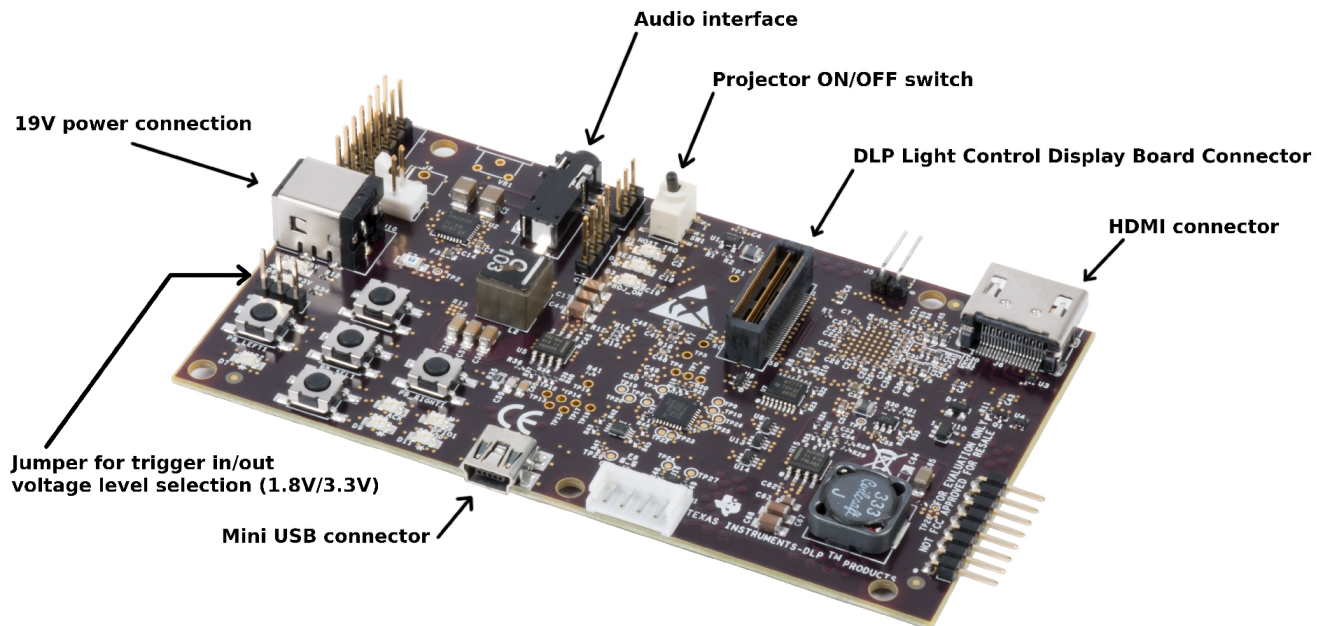

Figure 5. DLP3010 Light Control Main Board

The DLP3010 Light Control Display board has three main connectors: The LED connector, the flex cable connector, and the main board connector. The main and display board connect together via J5 and J9. Note that the main board connector J5 on the DLP3010 Light Control Display board is on the bottom, while the LED and flex cable connectors are on the top as shown in [Figure 6](#).

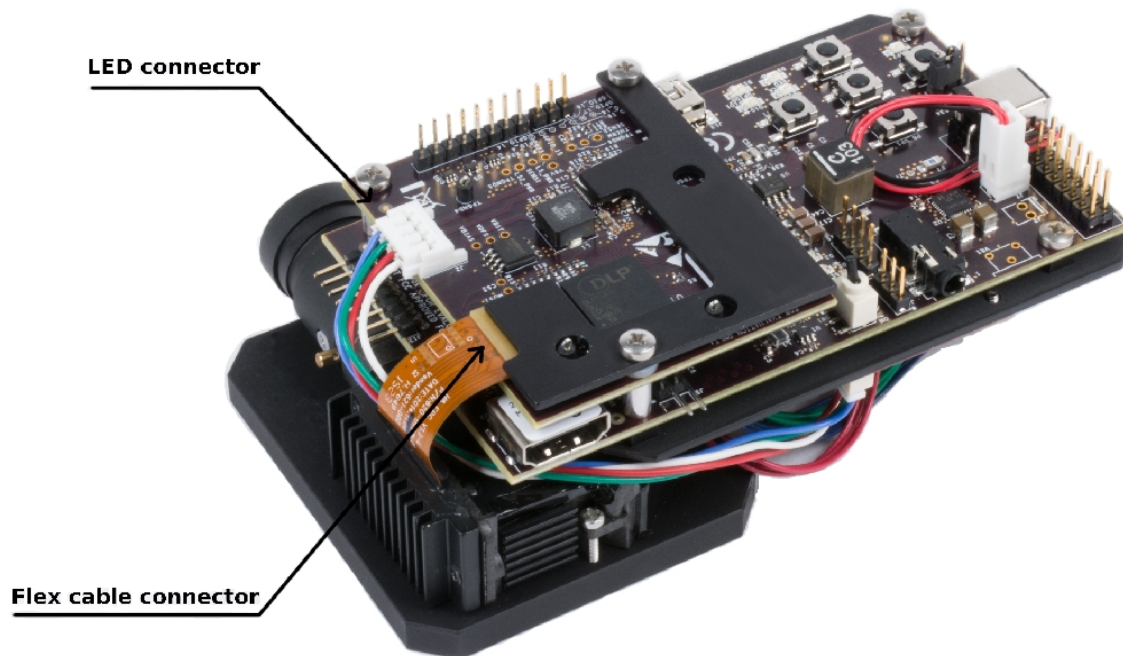

Figure 6. DLP3010 Light Control Connections

The LED adapter board connects the three LEDs with the LED connector on the DLP3010 Light Control Display board. The different connectors for each LED are named on the board as well as on the light engine. Refer to [Figure 7](#) to see the proper setup. The LEDs are connected accordingly to the LED datasheet specification.

Ensure a good connection of the flex cable to the DLP Light Control Display board before turning it on.

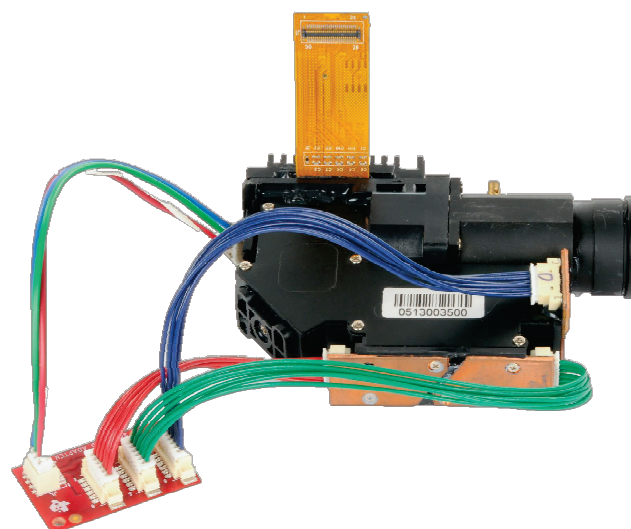

Figure 7. LED Connection

[Figure 8](#) shows the final setup of all parts.

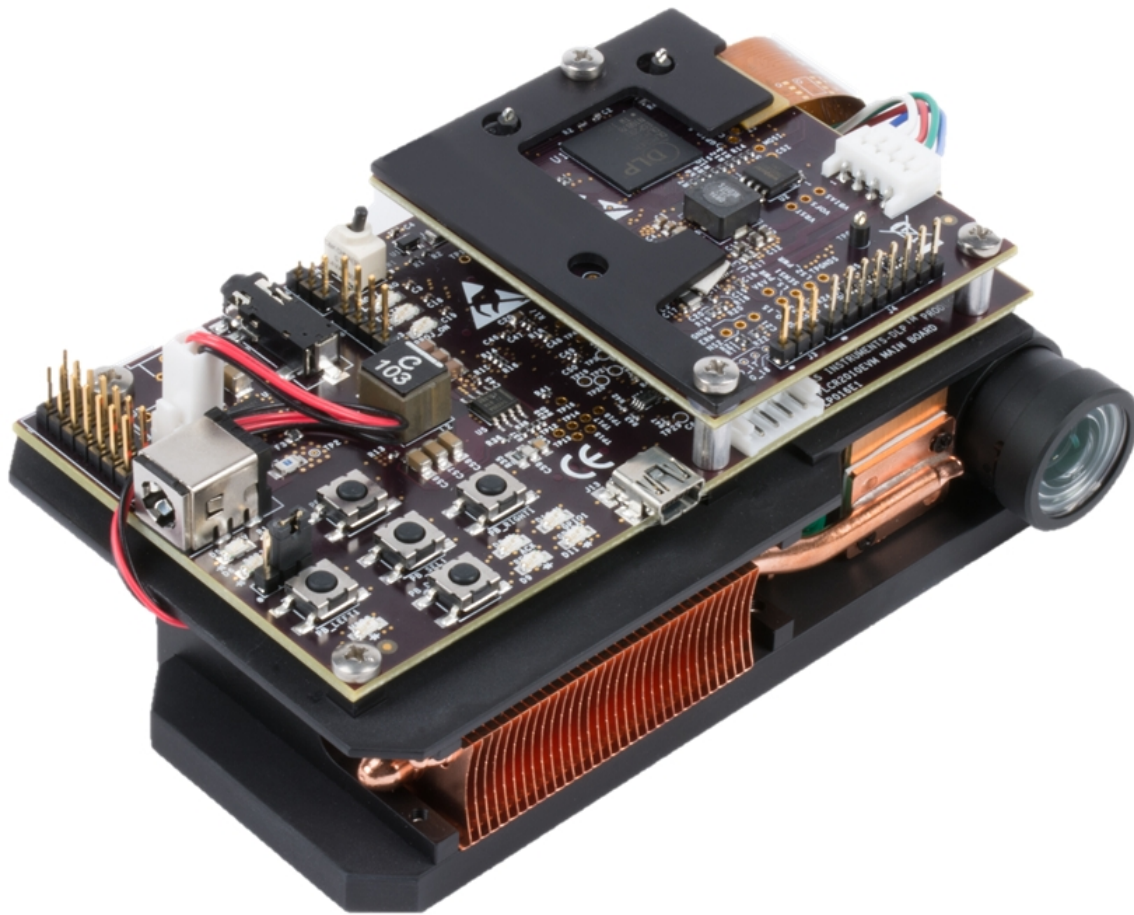

Figure 8. DLP3010 Light Control Complete EVM

Ensure that everything is set up correctly before continuing. Verify that the flex cable is connected correctly to the DLP3010 Light Control Display board.

Revision History

NOTE: Page numbers for previous revisions may differ from page numbers in the current version.

Changes from A Revision (October 2018) to B Revision Page

- Added pin mapping option description to [Section 5](#) 5

Changes from Original (July 2018) to A Revision Page

- Updated description of Step 1 and Step 6 in [Section 6](#) 6
 - Changed J10 connector description from "5-V" to "19-V" in [Table 3](#)..... 7
 - Added note for regarding board modification 8
-

IMPORTANT NOTICE AND DISCLAIMER

TI PROVIDES TECHNICAL AND RELIABILITY DATA (INCLUDING DATASHEETS), DESIGN RESOURCES (INCLUDING REFERENCE DESIGNS), APPLICATION OR OTHER DESIGN ADVICE, WEB TOOLS, SAFETY INFORMATION, AND OTHER RESOURCES "AS IS" AND WITH ALL FAULTS, AND DISCLAIMS ALL WARRANTIES, EXPRESS AND IMPLIED, INCLUDING WITHOUT LIMITATION ANY IMPLIED WARRANTIES OF MERCHANTABILITY, FITNESS FOR A PARTICULAR PURPOSE OR NON-INFRINGEMENT OF THIRD PARTY INTELLECTUAL PROPERTY RIGHTS.

These resources are intended for skilled developers designing with TI products. You are solely responsible for (1) selecting the appropriate TI products for your application, (2) designing, validating and testing your application, and (3) ensuring your application meets applicable standards, and any other safety, security, or other requirements. These resources are subject to change without notice. TI grants you permission to use these resources only for development of an application that uses the TI products described in the resource. Other reproduction and display of these resources is prohibited. No license is granted to any other TI intellectual property right or to any third party intellectual property right. TI disclaims responsibility for, and you will fully indemnify TI and its representatives against, any claims, damages, costs, losses, and liabilities arising out of your use of these resources.

TI's products are provided subject to TI's Terms of Sale (www.ti.com/legal/termsofsale.html) or other applicable terms available either on ti.com or provided in conjunction with such TI products. TI's provision of these resources does not expand or otherwise alter TI's applicable warranties or warranty disclaimers for TI products.

Mailing Address: Texas Instruments, Post Office Box 655303, Dallas, Texas 75265
Copyright © 2019, Texas Instruments Incorporated

Looking for pricing, stock, or lifecycle information?

Click below to explore more details on WIN SOURCE:

 [View DLP3010EVM-LC on WIN SOURCE](#)

 [Texas Instruments](#) Information

Optimize Your Supply Chain with WIN SOURCE Solutions

-  Global Sourcing Solution
-  Obsolete Management
-  Cost Control Management
-  Shortage Management
-  Alternative Solution
-  Excess Inventory Management