



**THE DATASHEET OF  
M22-5331405**





# HARWIN

## Component Specification

**C01812**

M22 Series Connectors  
November 2022

| SECTION    | TITLE   | PAGE |
|------------|---|------|
| 1          | Description of Connector and Intended Application | 2    |
| 2          | Ratings   | 2    |
| Appendix 1 | Gauges  | 4    |

## 1. DESCRIPTION OF CONNECTOR AND INTENDED APPLICATION

A range of 2mm pitch square pin connectors for interconnecting board to board. The socket is a box section design with barbs, to locate and hold in an insulated housing. Terminations are available for throughboard solder or surface mount in a vertical mounting.

The 0.5mm square plug pins are retained in a housing, and are available in either horizontal or vertical, throughboard solder mounting or surface mount.

Connectors are available in single and double row variations. Contacts may be gold with tin terminations, all-over gold or all-over tin plated.

## 2. RATINGS

Note:

- Individual components may exceed below ratings – check individual customer information sheets.
- Ratings for M22 Throughboard Pin Headers (including Pin header variants but excluding M22-220, M22-221 and M22-241 series), are detailed below as “M22-PH”.

### 2.1. Material & Finish

Housing Material:

For PC Tail or SMT connectors..... High Temperature Thermoplastic, UL94V-0  
For Cable connectors ..... See individual drawing

Contact Material ..... Copper alloy

Contact Finish ..... See individual drawing

### 2.2. Electrical Characteristics

Current Rating (per contact):

M22-301/302/304/305..... 1A max

Other ..... 2A max

Contact Resistance..... 20mΩ max

Dielectric Withstanding Voltage (Voltage Proof) ..... 500V AC/DC for 1 minute

Insulation Resistance..... 1,000MΩ min

### 2.3. Environmental Characteristics

Operating Temperature Range:

M22-301/302/304/305..... -25°C to +85°C

M22-220/221/306/307/308 ..... -25°C to +105°C

Others..... -40°C to +105°C

Vibration:

M22-PH, M22-241/532/533/543/634/636/654/655 ..... 50-2,000Hz, 3.13G<sub>rms</sub>,  
Duration 15 mins in each axis

Other ..... Not tested

Shock:

M22-PH, M22-241//532/533/543/634/636/654/655 ..... 30G for 11ms

Other ..... Not tested



## 2.4. Mechanical Characteristics

### Durability:

|  |                     |
|--|---------------------|
| M22-307 .....  | 1 operation MAXIMUM |
| <i>M22-307 is not designed to be pulled apart or separated easily. This connector is ideal for one cycle only.</i> |                     |
| M22-306/308 .....  | 100 operations      |
| Others: .....  | 300 operations      |

### Insertion Force (maximum):

|   |                   |
|---|-------------------|
| M22-304/305 .....                         | 2.94N per contact |
| M22-306/308 .....                         | 6.9N per contact  |
| M22-533/543/634/636/654/655/713/714 ..... | 2.0N per contact  |

### Withdrawal Force (minimum):

|   |                   |
|---|-------------------|
| M22-304/305/306/308 .....                 | 0.98N per contact |
| M22-533/543/634/636/654/655/713/714 ..... | 0.2N per contact  |

### Contact Retention Force (minimum):

|                                       |                  |
|---------------------------------------|------------------|
| M22-PH, M22-220/221/306/308/530 ..... | 9.8N per contact |
| M22-241/532/533/543/655/713/714 ..... | 4.9N per contact |

## 2.5. Soldering Data

### Solderability (for PC Tail & SMT products):

|   |                     |
|---|---------------------|
| M22-220/221 .....                             | 235°C for 3 seconds |
| M22-PH, M22-241/532/533/543/634/636/655 ..... | 245°C for 5 seconds |
| M22-530 .....                                 | 250°C for 5 seconds |



**APPENDICES NOTES:**

1. Third angle projection is used where projected views are shown.
2. All dimensions are in millimetres.
3. For explanation of dimensions, etc. see BS8888.
4. Unless otherwise stated, all dimensions are maxima.

**APPENDIX 1 – GAUGES**

**NOTES:**

1. Material = Steel to BS1407 or equivalent.
2. Gauging surfaces to be hardened/ground, 650 HV5 min.
3. These gauges to be used for testing fully assembled components only.
4. Ultimate wear limit 0.005mm is allowable on gauging dimensions.

**A1.1. Sizing Gauge**

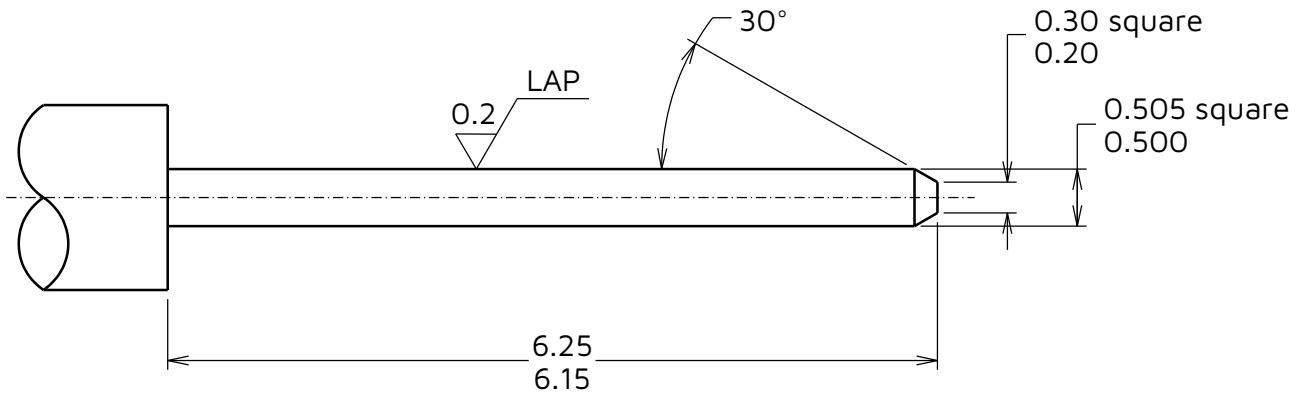

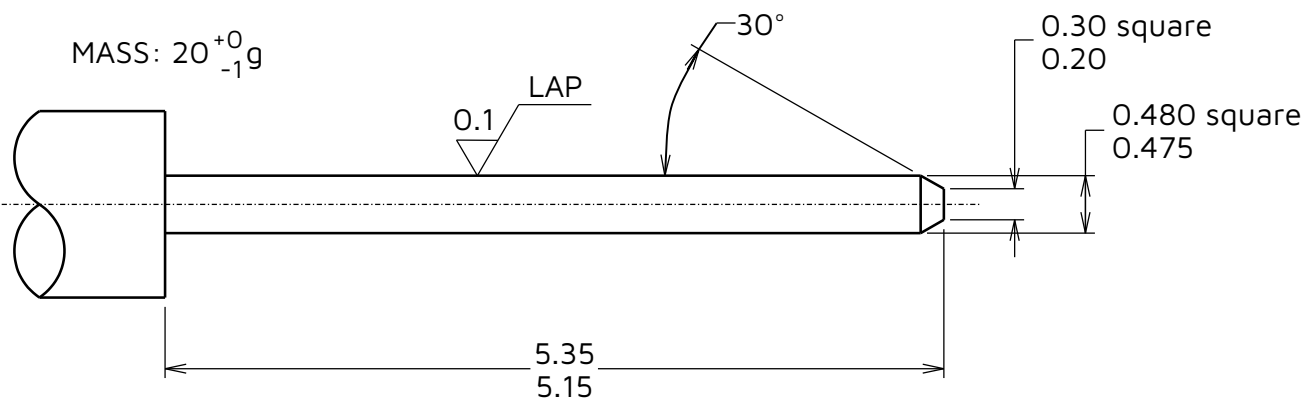

**A1.2. Holding Gauge (after conditioning)**



## Looking for pricing, stock, or lifecycle information?

Click below to explore more details on WIN SOURCE:

-  [View M22-5331405 on WIN SOURCE](#)
-  [Harwin Inc. Information](#)

## Optimize Your Supply Chain with WIN SOURCE Solutions

-  Global Sourcing Solution
-  Obsolete Management
-  Cost Control Management
-  Shortage Management
-  Alternative Solution
-  Excess Inventory Management