



**THE DATASHEET OF**  
**0242.080UR**



242 Series Barrier Fuse



**Description**

The 242 Series fuse is designed for barrier circuits in intrinsic safety applications relating to Hazardous Locations. Ranging from 40mA to 250mA, the 242 Series provides overcurrent protection solutions to fit many Hazardous Location barrier applications.

**Features**

- High interrupting rating suitable for intrinsic safety protection of hazardous locations equipment.
- Available in both axial lead and surface mount.
- RoHS compliant and Halogen-free.

**Applications**

- Intrinsic safety electrical equipment; Electrical connections and components; Test equipment
- Barriers providing intrinsically safe outputs to Hazardous Locations

**Agency Approvals**

Agency	Agency File Number	Ampere Range
<b>C <b>UL</b> US</b>	E10480	0.040A - 0.250A

**Electrical Characteristics**

% of Ampere Rating	Opening Time
100%	4 hours, Minimum
300%	10 seconds, Maximum
1000%	0.002 seconds, Maximum

**Additional Information**



Datasheet



Resources



Samples

**Electrical Characteristics**

Ampere Rating (A)	Amp Code	Body Color Coding	Interrupting Rating	Nominal Cold Resistance (Ohms)	Nominal Melting I <sup>2</sup> t (A <sup>2</sup> Sec.)	Agency Approvals
						<b>C <b>UL</b> US</b>
0.040	.040	Gold	4000A @ 250VAC/VDC	16.48	0.000078	x
0.050	.050	Red		11.34	0.000103	x
0.080	.080	Green		8.19	0.000214	x
0.100	.100	Blue		3.60	0.000977	x
0.125	.125	Orange		3.78	0.001026	x
0.160	.160	Violet		3.00	0.00157	x
0.200	.200	Brown		2.68	0.0025	x
0.250	.250	Black		1.6	0.00579	x

**Disclaimer Notice** - Information furnished is believed to be accurate and reliable. However, users should independently evaluate the suitability of and test each product selected for their own applications. Littelfuse products are not designed for, and may not be used in, all applications. Read complete Disclaimer Notice at: [www.littelfuse.com/disclaimer-electronics](http://www.littelfuse.com/disclaimer-electronics).

### Temperature De-Rating Curve

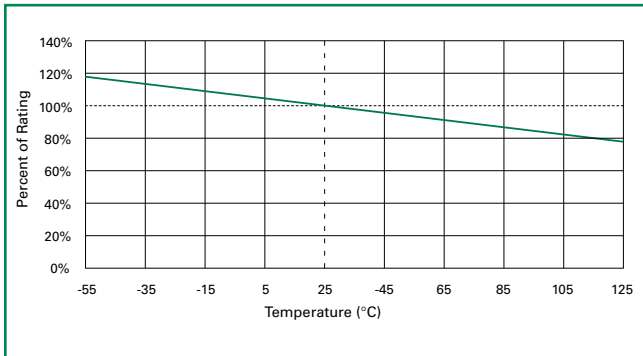

### Average Time Current Curves

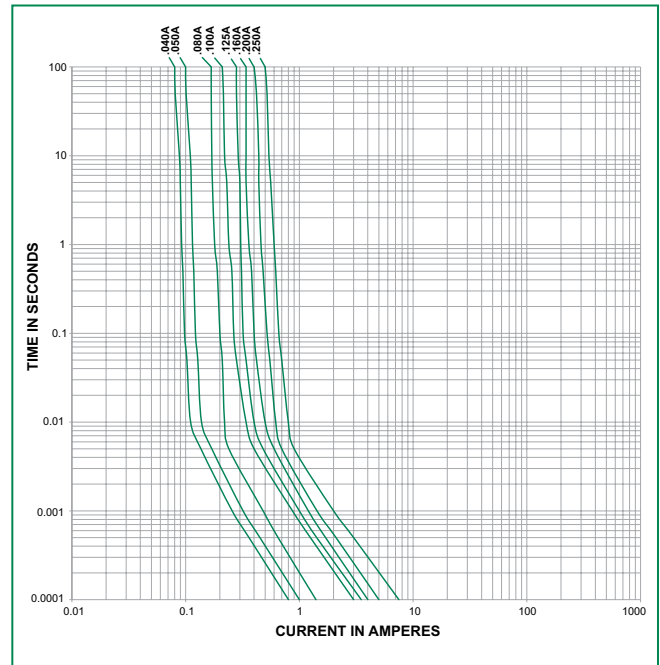

### Soldering Parameters

Reflow Condition		Pb – Free assembly
Pre Heat	- Temperature Min ( $T_{s(min)}$ )	150°C
	- Temperature Max ( $T_{s(max)}$ )	200°C
	- Time (min to max) ( $t_s$ )	60 – 180 secs
Average ramp up rate (Liquidus Temp ( $T_L$ ) to peak)		5°C/second max
$T_{s(max)}$ to $T_L$ - Ramp-up Rate		5°C/second max
Reflow	- Temperature ( $T_L$ ) (Liquidus)	217°C
	- Temperature ( $t_l$ )	60 – 150 seconds
Peak Temperature ( $T_p$ )		250 <sup>+0/-5</sup> °C
Time within 5°C of actual peak Temp. ( $t_p$ )		20 – 40 seconds
Ramp-down Rate		5°C/second max
Time 25°C to peak Temperature ( $T_p$ )		8 minutes Max.
Do not exceed		260°C

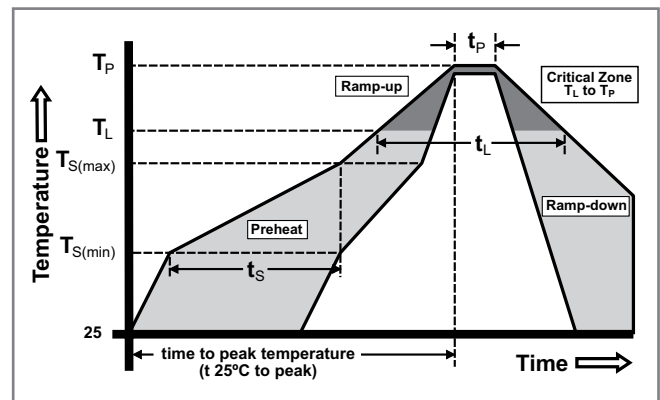

Wave Soldering

260°C, 10 seconds max.

### Material Information

<b>Body</b>	Ceramic
<b>Leads</b>	Tin-Plated Copper
<b>Endcaps</b>	Silver-Plated Brass

### Product Characteristics

<b>Operating Temperature</b>	-40°C to 125°C (Consider re-rating)
<b>Thermal Shock</b>	Withstands 5 cycles of - 55°C to 125°C
<b>Vibration</b>	Per MIL-STD-202 Method 201
<b>Insulation Resistance (After Opening)</b>	Greater than 10,000 ohms.

**Dimensions**

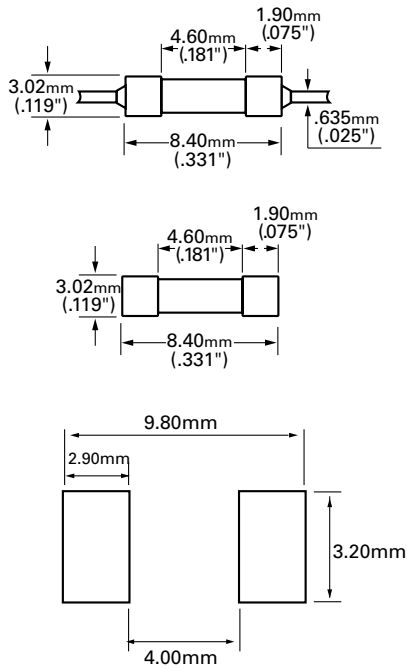

**Part Numbering System**

**0242.050UAT1**

**SERIES** \_\_\_\_\_  
**AMP CODE** \_\_\_\_\_  
 Refer to Amp Code column in the Electrical Specifications table.  
**QUANTITY & PACKAGING CODE** \_\_\_\_\_  
 HAT1 = 100 pcs, Axial Leaded, Ammo Pack T1 Tape  
 UAT1 = 500 pcs, Axial Leaded, Ammo Pack T1 Tape  
 UR = 500 pcs, Surface Mount, Tape & Reel

**Disclaimer Notice** - Information furnished is believed to be accurate and reliable. However, users should independently evaluate the suitability of and test each product selected for their own applications. Littelfuse products are not designed for, and may not be used in, all applications. Read complete Disclaimer Notice at: [www.littelfuse.com/disclaimer-electronics](http://www.littelfuse.com/disclaimer-electronics).

## Looking for pricing, stock, or lifecycle information?

Click below to explore more details on WIN SOURCE:

 [View 0242.080UR on WIN SOURCE](#)

 [Littelfuse Inc. Information](#)

## Optimize Your Supply Chain with WIN SOURCE Solutions

-  Global Sourcing Solution
-  Obsolete Management
-  Cost Control Management
-  Shortage Management
-  Alternative Solution
-  Excess Inventory Management