



**THE DATASHEET OF
TLE49663KHTSA1**



TLE4966-3K

High Sensitivity Automotive Hall Switch with direction detection

Datasheet

Rev.1.0, 2010-09-20

Edition 2010-09-20

**Published by
Infineon Technologies AG
81726 Munich, Germany**

**© 2010 Infineon Technologies AG
All Rights Reserved.**

Legal Disclaimer

The information given in this document shall in no event be regarded as a guarantee of conditions or characteristics. With respect to any examples or hints given herein, any typical values stated herein and/or any information regarding the application of the device, Infineon Technologies hereby disclaims any and all warranties and liabilities of any kind, including without limitation, warranties of non-infringement of intellectual property rights of any third party.

Information

For further information on technology, delivery terms and conditions and prices, please contact the nearest Infineon Technologies Office (www.infineon.com).

Warnings

Due to technical requirements, components may contain dangerous substances. For information on the types in question, please contact the nearest Infineon Technologies Office.

Infineon Technologies components may be used in life-support devices or systems only with the express written approval of Infineon Technologies, if a failure of such components can reasonably be expected to cause the failure of that life-support device or system or to affect the safety or effectiveness of that device or system. Life support devices or systems are intended to be implanted in the human body or to support and/or maintain and sustain and/or protect human life. If they fail, it is reasonable to assume that the health of the user or other persons may be endangered.

Revision History: 2010-09-20, Rev.1.0

Previous Revision:

Page	Subjects (major changes since last revision)

Trademarks of Infineon Technologies AG

ABM™, BlueMoon™, CONVERGATE™, COSIC™, C166™, FALC™, GEMINAX™, GOLDMOS™, ISAC™, OMNITUNE™, OMNIVIA™, PROSOC™, SEROCCO™, SICOFI™, SIEGET™, SMARTi™, SMINT™, SOCRATES™, VINAX™, VINETIC™, VOIPRO™, X-GOLD™, XMM™, X-PMU™, XWAY™

Other Trademarks

Microsoft®, Visio®, Windows®, Windows Vista®, Visual Studio®, Win32® of Microsoft Corporation. Linux® of Linus Torvalds. FrameMaker®, Adobe® Reader™, Adobe Audition® of Adobe Systems Incorporated. APOXI®, COMNEON™ of Comneon GmbH & Co. OHG. PrimeCell®, RealView®, ARM®, ARM® Developer Suite™ (ADS), Multi-ICE™, ARM1176JZ-S™, CoreSight™, Embedded Trace Macrocell™ (ETM), Thumb®, ETM9™, AMBA™, ARM7™, ARM9™, ARM7TDMI-S™, ARM926EJ-S™ of ARM Limited. OakDSPCore®, TeakLite® DSP Core, OCEM® of ParthusCeva Inc. IndoorGPS™, GL-20000™, GL-LN-22™ of Global Locate. mipi™ of MIPI Alliance. CAT-iq™ of DECT Forum. MIPS™, MIPS II™, 24KEc™, MIPS32®, 24KEc™ of MIPS Technologies, Inc. Texas Instruments®, PowerPAD™, C62x™, C55x™, VLYNQ™, Tology Software™, TMS320C62x™, Code Composer Studio™, SSI™ of Texas Instruments Incorporated. Bluetooth® of Bluetooth SIG, Inc. IrDA® of the Infrared Data Association. Java™, SunOS™, Solaris™ of Sun Microsystems, Inc. Philips®, I2C-Bus® of Koninklijke Philips Electronics N.V. Epson® of Seiko Epson Corporation. Seiko® of Kabushiki Kaisha Hattori Seiko Corporation. Panasonic® of Matsushita Electric Industrial Co., Ltd. Murata® of Murata Manufacturing Company. Taiyo Yuden™ of Taiyo Yuden Co., Ltd. TDK® of TDK Electronics Company, Ltd. Motorola® of Motorola, Inc. National Semiconductor®, MICROWIRE™ of National Semiconductor Corporation. IEEE® of The Institute of Electrical and Electronics Engineers, Inc. Samsung®, OneNAND®, UtRAM® of Samsung Corporation. Toshiba® of Toshiba Corporation. Dallas Semiconductor®, 1-Wire® of Dallas Semiconductor Corp. ISO® of the International Organization for Standardization. IEC™ of the International Engineering Consortium. EMV™ of EMVCo, LLC. Zetex® of Zetex Semiconductors. Microtec® of Microtec Research, Inc. Verilog® of Cadence Design Systems, Inc. ANSI® of the American National Standards Institute, Inc. WindRiver® and VxWorks® of Wind River Systems, Inc. Nucleus™ of Mentor Graphics Corporation. OmniVision® of OmniVision Technologies, Inc. Sharp® of Sharp Corporation. Symbian OS® of Symbian Software Ltd. Openwave® of Openwave Systems, Inc. Maxim® of Maxim Integrated Products, Inc. Spansion® of Spansion LLC. Micron®, CellularRAM® of Micron Technology, Inc. RFMD® of RF Micro Devices, Inc. EPCOS® of EPCOS AG. UNIX® of The Open Group. Tektronix® of Tektronix, Inc. Intel® of Intel Corporation. Qimonda® of Qimonda AG. 1GOneNAND® of Samsung Corporation. HyperTerminal® of Hilgraeve, Inc. MATLAB® of The MathWorks, Inc. Red Hat® of Red Hat, Inc. Palladium® of Cadence Design Systems, Inc. SIRIUS Satellite Radio® of SIRIUS Satellite Radio Inc. TOKO® of TOKO Inc.

The information in this document is subject to change without notice.

Last Trademarks Update 2008-11-17

	Trademarks of Infineon Technologies AG	3
1	Overview	5
1.1	Features	5
1.2	Functional Description	5
1.3	Pin Configuration (top view)	6
2	General	7
2.1	Block Diagram	7
2.2	Circuit Description	7
2.3	Application Circuit	8
3	Maximum Ratings	8
4	Operating Range	9
5	Electrical and Magnetic Parameters	10
	Field Direction Definition	11
6	Timing Diagrams for the Speed and Direction Output	11
7	Package Information	13
7.1	Package Marking	13
7.2	Distance between Chip and Package Surface	13
7.3	Package Outlines	13
	PCB Footprint for PG-TSOP-6-6-5	14



1 Overview

1.1 Features

- 2.7V to 24V supply voltage operation
- Operation from unregulated power supply
- High sensitivity and high stability of the magnetic switching points
- High resistance to mechanical stress by Active Error Compensation
- Reverse battery protection (-18V)
- Superior temperature stability
- Peak temperatures up to 195°C
- Low jitter (typ. 1µs)
- Digital output signals
- Excellent matching of the 2 Hall probes
- Hall plate distance 1.45mm
- Speed and direction output signal
- SMD package PG-TSOP-6-6-5



1.2 Functional Description

The TLE4966-3K is an integrated circuit dual Hall-effect sensor designed specifically for highly accurate applications which use a rotating pole wheel. Precise magnetic switching points and high temperature stability are achieved by active compensation circuits and chopper techniques on chip. The sensor provides a speed output at Q2 with the status (high or low) corresponding to the magnetic field value. For positive magnetic fields (south pole) exceeding the threshold B_{OP} the output is low, whereas for negative magnetic fields (north pole) lower than B_{RP} the output switches to high. The output Q1 can be either high or low depending on the direction of rotation of the pole wheel. This direction information is calculated internally.

Product Name	Product Type	Ordering Code	Package
TLE4966-3K	Double Hall Switch	SP000835522	PG-TSOP-6-6-5

1.3 Pin Configuration (top view)

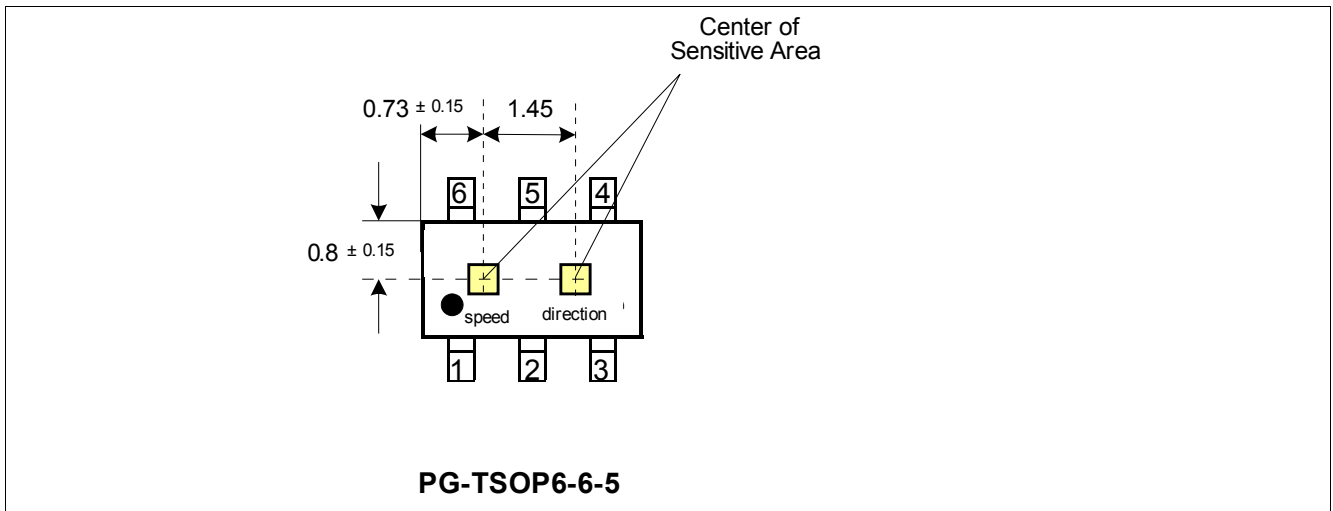

Figure 1 Pin Definition and Center of Sensitive Area

Table 1 Pin Definitions and Functions

Pin No.	Symbol	Function
1	Q2	Speed
2	GND	Recommended connection to GND
3	Q1	Direction
4	V_{DD}	Supply voltage
5	GND	Recommended connection to GND
6	GND	Ground

2 General

2.1 Block Diagram

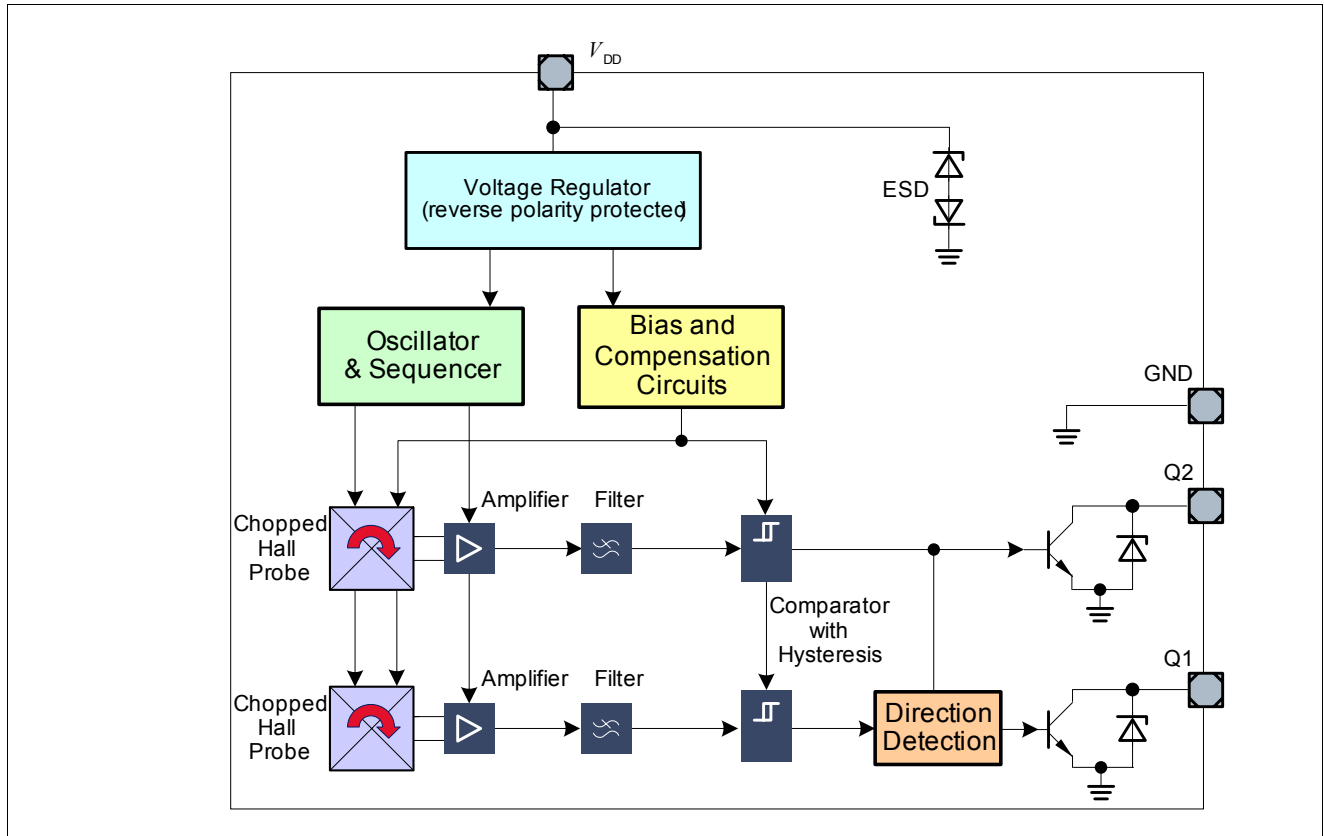

Figure 2 Block Diagram

2.2 Circuit Description

The chopped Dual Hall Switch comprises two Hall probes, bias generator, compensation circuits, oscillator, and output transistors.

The bias generator provides currents for the Hall probes and the active circuits. Compensation circuits stabilize the temperature behavior and reduce influence of technology variations.

The Active Error Compensation rejects offsets in signal stages and the influence of mechanical stress to the Hall probes caused by molding and soldering processes and other thermal stresses in the package. This chopper technique together with the threshold generator and the comparator ensures high accurate magnetic switching thresholds.

2.3 Application Circuit

It is recommended to use a series resistor R_S with 200Ω and a capacitor of $C_S = 4.7\text{nF}$ for protection against overvoltage and transients on the supply line. Pull-up resistors R_L are required for the output pins Q_1 and Q_2 .

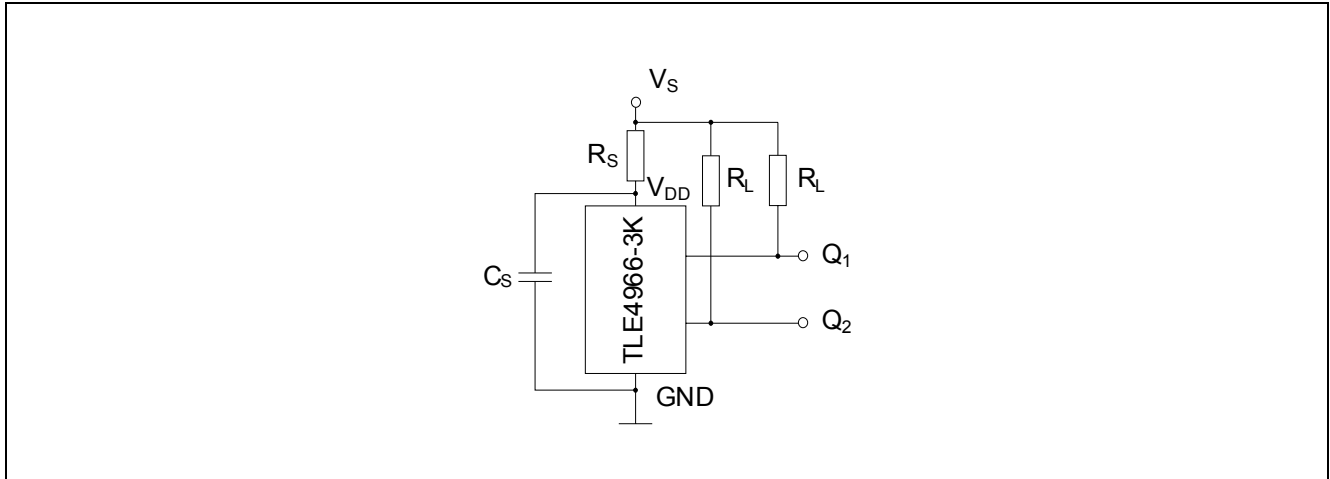

Figure 3 Application Circuit

3 Maximum Ratings

Table 2 Absolute Maximum Ratings

$T_j = -40^\circ\text{C}$ to 150°C

Parameter	Symbol	Limit Values		Unit	Conditions
		min.	max.		
Supply voltage	V_{DD}	-18	18	V	for 1 h, $R_S \geq 200 \Omega$ for 5 min, $R_S \geq 200 \Omega$
	V_S	-18	24		
	V_S	-18	26		
Supply current through protection device	I_{DD}	-50	50	mA	
Output voltage	V_Q	-0.7 -0.7	18 26	V	for 5 min @ $R_L = 1.2 \text{ k}\Omega$ (pull up resistor)
Continuous output current	I_Q	-50	50	mA	
Junction temperature	T_j	-	155	$^\circ\text{C}$	for 2000 h (not additive)
		-	165		for 1000 h (not additive)
		-	175		for 168 h (not additive)
		-	195		for 3 x 1 h (additive)
Storage temperature	T_S	-40	150	$^\circ\text{C}$	
Magnetic flux density	B	-	unlimited	mT	

Note: Stresses above the max. values listed here may cause permanent damage to the device. Exposure to absolute maximum rating conditions for extended periods may affect device reliability. Maximum ratings are absolute ratings; exceeding only one of these values may cause irreversible damage to the integrated circuit.

Table 3 ESD Protection ¹⁾

Parameter	Symbol	Limit Values		Unit	Notes
		min.	max.		
ESD voltage	V_{ESD}	–	± 4	kV	HBM, $R = 1.5 \text{ k}\Omega$, $C = 100 \text{ pF}$ $T_A = 25^\circ\text{C}$

1) Human Body Model (HBM) tests according to: EOS/ESD Association Standard S5.1-1993 and Mil. Std. 883D method 3015.7

4 Operating Range

The following operating conditions must not be exceeded in order to ensure correct operation of the TLE4966-3K. All parameters specified in the following sections refer to these operating conditions unless otherwise mentioned.

Table 4 Operating Range

Parameter	Symbol	Limit Values			Unit	Conditions
		min.	typ.	max.		
Supply voltage	V_{DD}	2.7	–	18	V	1 h with $R_S \geq 200 \Omega$ for 5 min $R_S \geq 200 \Omega$
	V_S	–	–	24		
	V_S	–	–	26		
Output voltage	V_Q	-0.7	–	18	V	
Junction temperature	T_j	-40	–	150	°C	for 168 h
		–	–	175		
Output current	I_Q	0	–	10	mA	

5 Electrical and Magnetic Parameters

Product characteristics involve the spread of values guaranteed within the specified voltage and temperature range. Typical characteristics are the median of the production and correspond to $V_D = 12V$ and $T_A = 25^\circ C$.

Table 5 Electrical Characteristics ¹⁾

Parameter	Symbol	Limit Values			Unit	Conditions
		min.	typ.	max.		
Supply current	I_{DD}	4	5.2	7	mA	$V_{DD} = 2.7 V \dots 18 V$
Reverse current	I_{SR}	0	0.2	1	mA	$V_{DD} = -18 V$
Output saturation voltage	V_{QSAT}	–	0.3	0.6	V	$I_Q = 10 mA$
Output leakage current	I_{QLEAK}	–	0.05	10	μA	for $V_Q = 18 V$
Output fall time	t_f	–	0.2	1	μs	$R_L = 1.2 k\Omega$; $C_L < 50 pF$
Output rise time	t_r	–	0.2	1	μs	see: Figure 4 on Page 11
Chopper frequency	f_{OSC}	–	320	–	kHz	
Switching frequency	f_{SW}	0	–	15 ²⁾	kHz	
Delay time ³⁾	t_d	–	13	–	μs	
Count Signal Delay	t_{dc}	50	200	1000	ns	see: Figure 5 on Page 12
Output jitter ⁴⁾	t_{QJ}	–	1	–	μs_{RMS}	Typ. value for square wave signal 1 kHz
Repeatability of magnetic thresholds ⁵⁾	B_{REP}	–	40	–	μT_{RMS}	Typ. value for $\Delta B/\Delta t > 12 mT/ms$
Power-on time ⁶⁾	t_{PON}	–	13	–	μs	$V_{DD} \geq 2.7 V$
Distance of hall plates	d_{HALL}	–	1.45	–	mm	
Thermal resistance ⁷⁾	R_{thJA}	–	100	–	K/W	PG-TSOP-6-6-5

- 1) over operating range, unless otherwise specified. Typical values correspond to $V_{DD} = 12 V$ and $T_A = 25^\circ C$
- 2) To operate the sensor at the max. switching frequency, the magnetic signal amplitude must be 1.4 times higher than for static fields. This is due to the -3 dB corner frequency of the low pass filter in the signal path.
- 3) Systematic delay between magnetic threshold reached and output switching
- 4) Jitter is the unpredictable deviation of the output switching delay
- 5) B_{REP} is equivalent to the noise constant
- 6) Time from applying $V_{DD} \geq 2.7 V$ to the sensor until the output state is valid
- 7) Thermal resistance from junction to ambient

Calculation of the ambient temperature (PG-TSOP-6-6-5 example)

e.g. for $V_{DD} = 12.0 V$, $I_{DDtyp} = 5.5 mA$, $V_{QSATtyp} = 0.3 V$ and $2 \times I_Q = 10 mA$:
 Power Dissipation: $P_{DIS} = 72.0 mW$.
 In $T_A = T_j - (R_{thJA} \times P_{DIS}) = 175^\circ C - (100 K / W \times 0.072 W)$
 Resulting max. ambient temperature: $T_A = 167.8^\circ C$

Table 6 Magnetic Characteristics ¹⁾.

Parameter	Symbol	Limit Values			Unit	Conditions
		min.	typ.	max.		
Operate point	B_{OP}	0.8	2.5	4.2	mT	
Release point	B_{RP}	-4.2	-2.5	-0.8	mT	
Hysteresis	B_{HYS}	3.7	5.0	6.3	mT	
Magnetic matching	B_{MATCH}	-2.0		2.0	mT	Valid for $T_A = 25^\circ\text{C}$ $B_{OP1} - B_{OP2}$ and $B_{RP1} - B_{RP2}$
Temperature compensation of magnetic thresholds	TC	-	-350	-	ppm/ $^\circ\text{C}$	

1) over operating range, unless otherwise specified. Typical values correspond to $V_{DD} = 12\text{ V}$ and $T_A = 25\text{C}$

Field Direction Definition

Positive magnetic fields related with south pole of the magnet to the branded side of package.

6 Timing Diagrams for the Speed and Direction Output

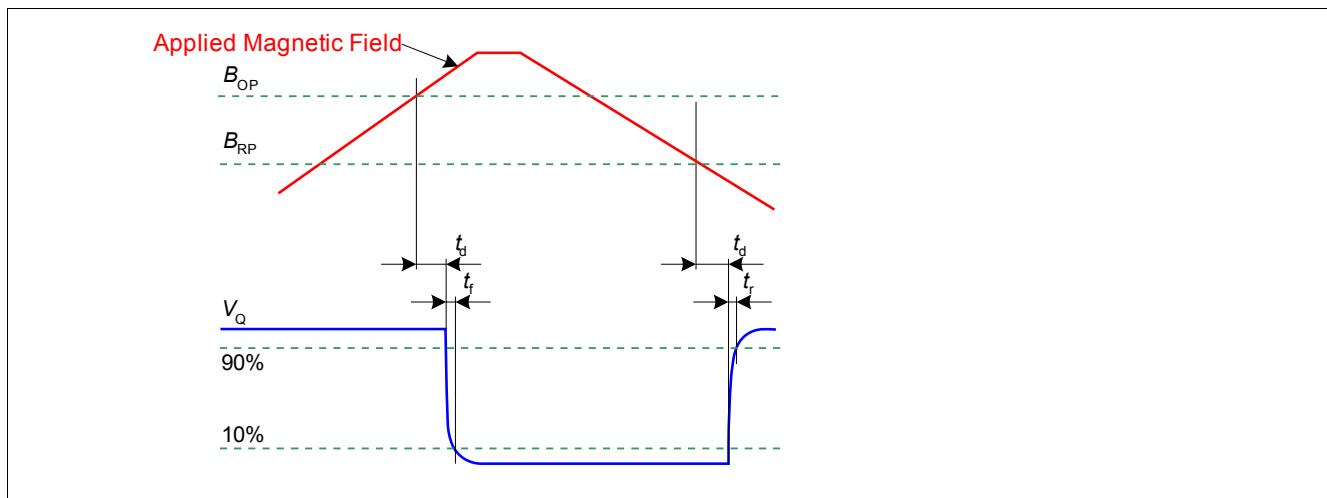

Figure 4 Timing Definition of the Speed Signal

Timing Diagrams for the Speed and Direction Output

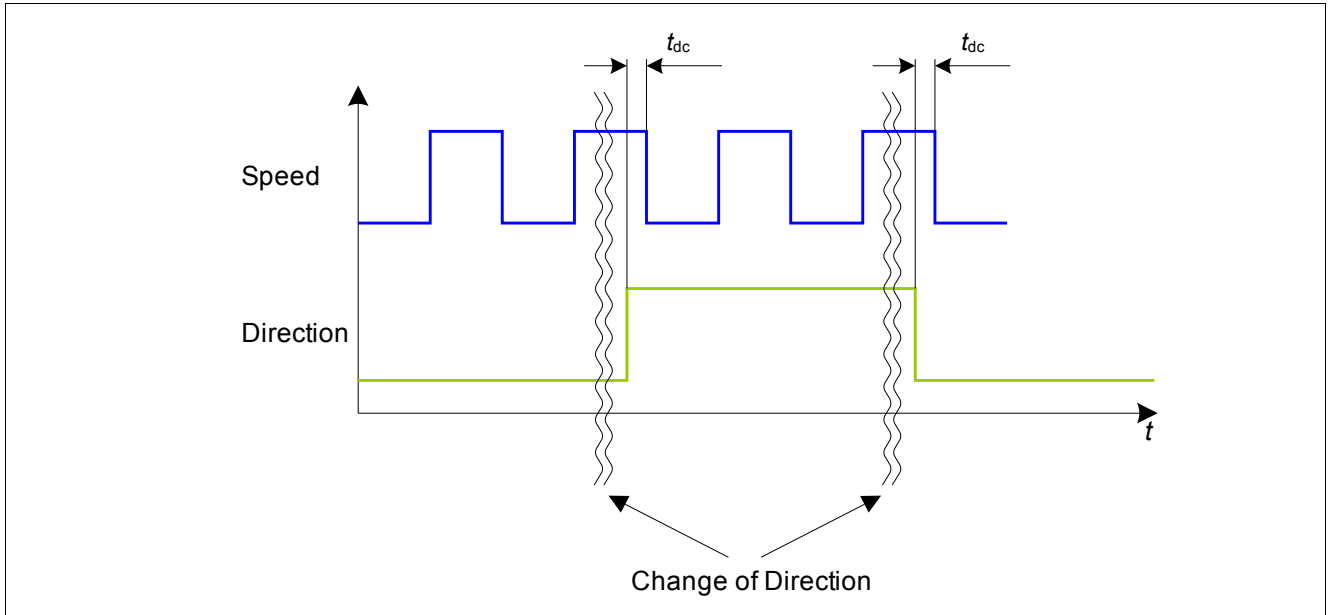

Figure 5 Timing Definition of the direction signal

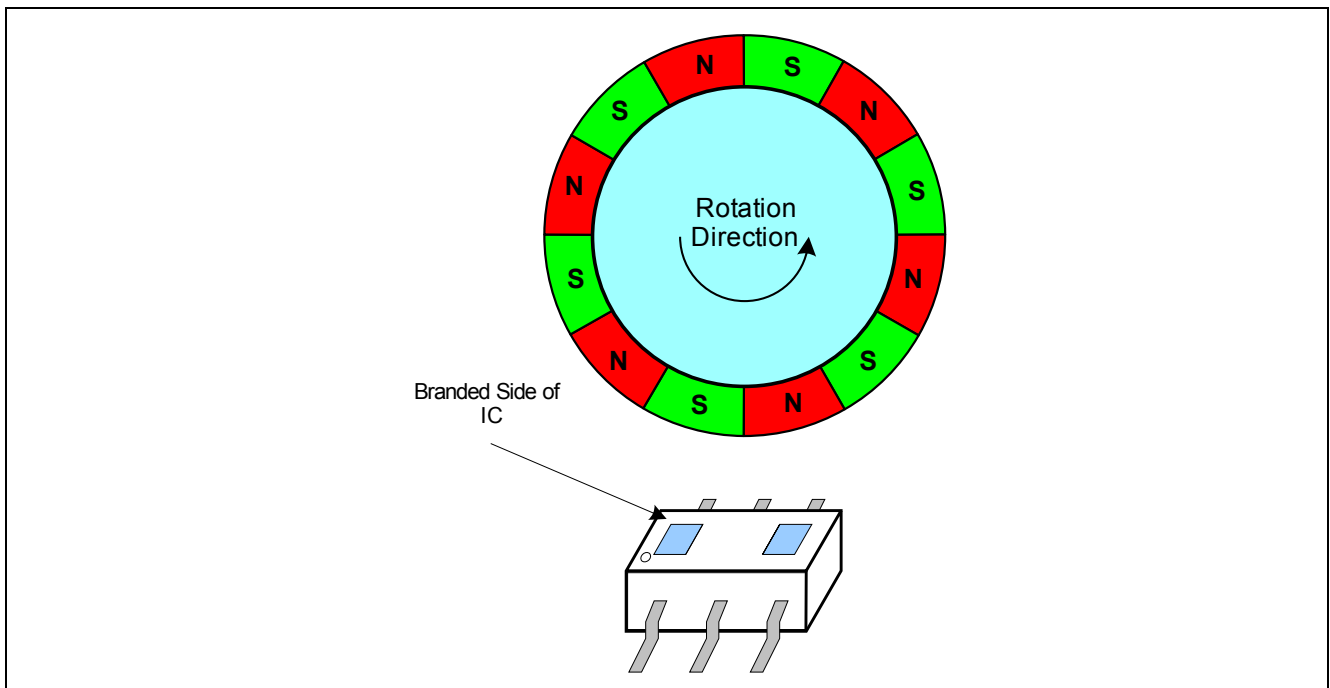

Figure 6 Definition of the direction signal

Rotation direction	State of direction output Q1
Left to right	Low
Right to Left	High

7 Package Information

7.1 Package Marking

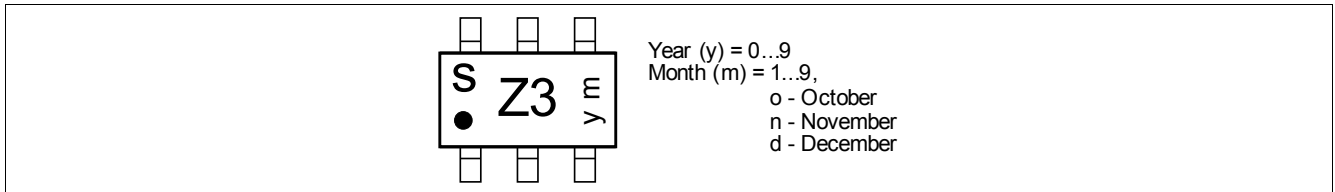

Figure 7 Marking PG-TSOP-6-6-5

7.2 Distance between Chip and Package Surface

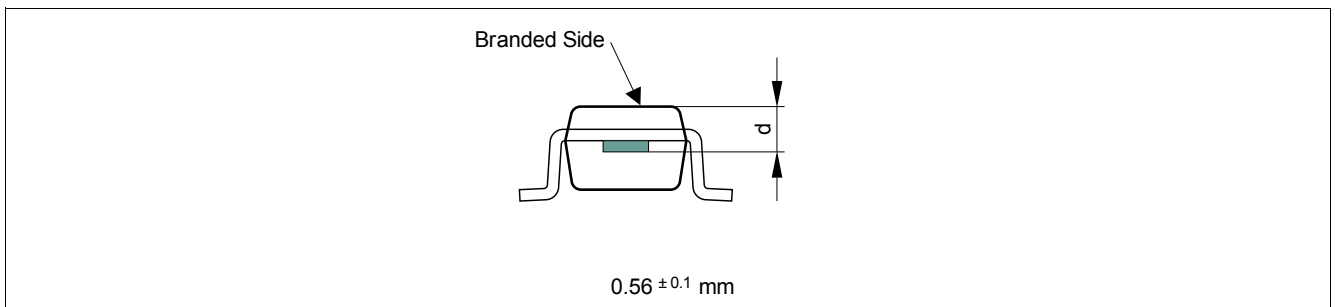

Figure 8 Distance Chip to Upper Side of IC

7.3 Package Outlines

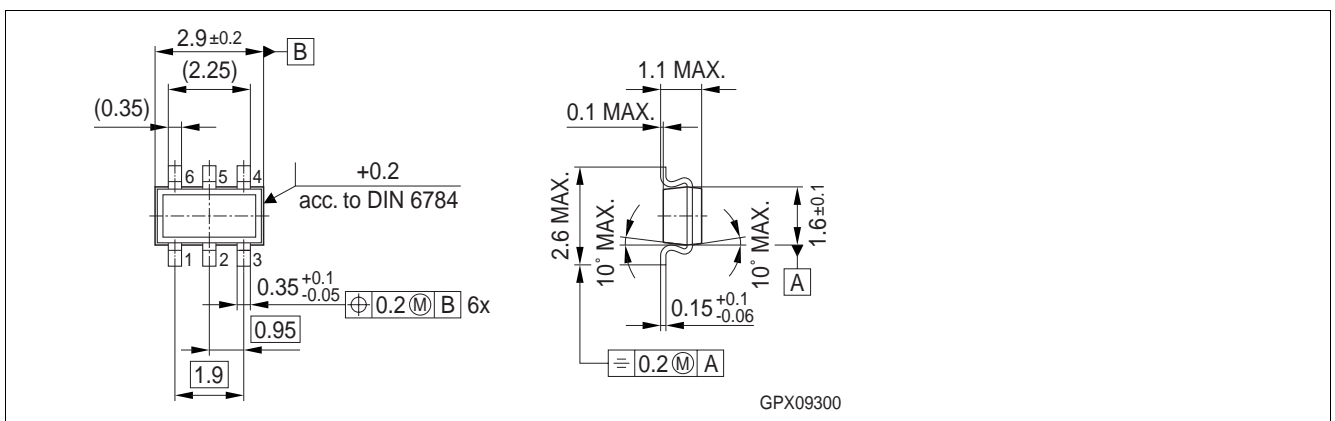

Figure 9 PG-TSOP-6-6-5 (Plastic Thin Small Outline Package)

PCB Footprint for PG-TSOP-6-6-5

The following picture shows a recommendation for the PCB layout.

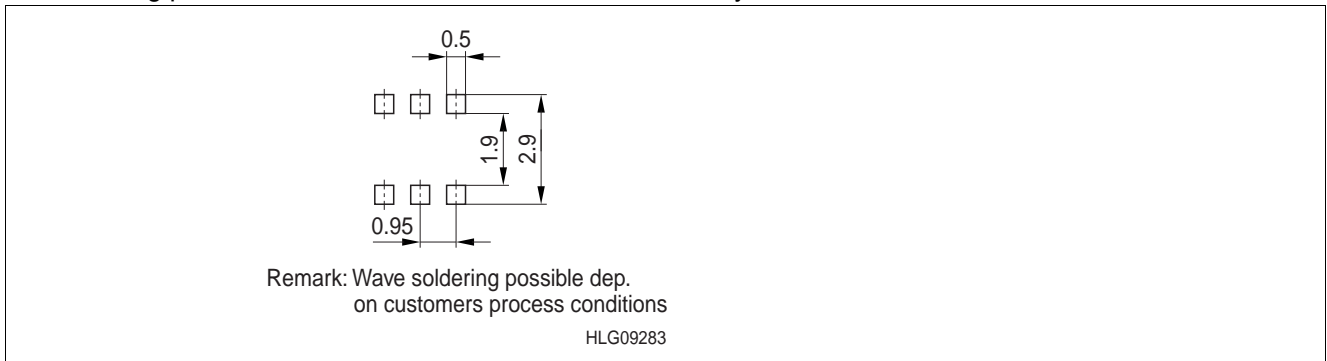



Figure 10 Footprint PG-TSOP-6-6-5

www.infineon.com

Published by Infineon Technologies AG

Looking for pricing, stock, or lifecycle information?

Click below to explore more details on WIN SOURCE:

-  [View TLE49663KHTSA1 on WIN SOURCE](#)
-  [Infineon Technologies Information](#)

Optimize Your Supply Chain with WIN SOURCE Solutions

-  Global Sourcing Solution
-  Obsolete Management
-  Cost Control Management
-  Shortage Management
-  Alternative Solution
-  Excess Inventory Management