



THE DATASHEET OF CMD5D11NP-100MC



Type: CMD5D11
◆ Product Description

- 7.4 × 5.8mm Max.(L×W), 1.2mm Max. Height.
- Inductance Range: 3.3~100 μH
- Rated current range: 200~940mA.
- 4 Terminal pins' type gives a flexible design as inductors or transformers(SEPIC,ZETA circuit).
- In addition to the standards versions used as power inductors shown here, custom designs as transformers(SEPIC,ZETA circuit) and inductors are also available.

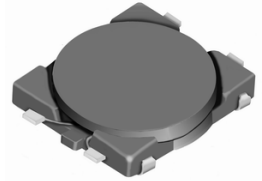
◆ Feature

- Magnetically unshielded construction.
- Ideally used in portable devices such as Mobilephone,DSC/DVC,MP3,PDA, etc as DC-DC Converter inductors, specially suitable for White LED drive.
- RoHS Compliance

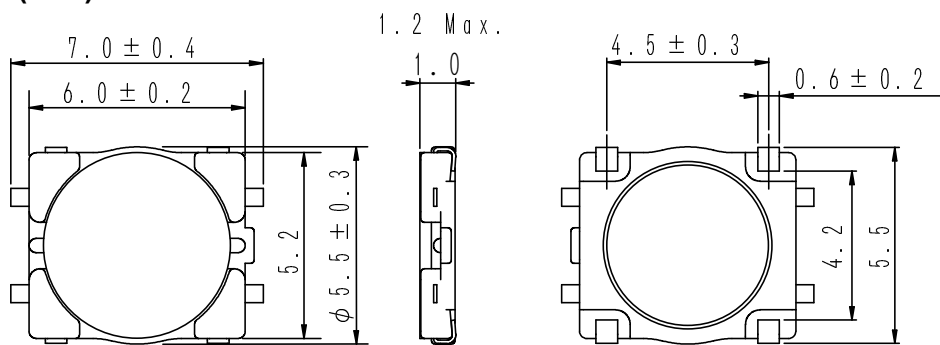
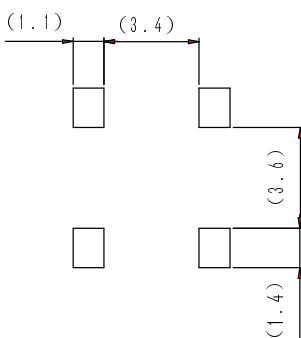
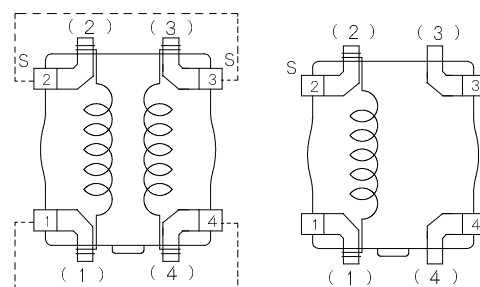
◆ Dimensions (mm)

◆ Land Pattern (mm)

◆ Schematics(Bottom)

(3.3 μH~15 μH)

(22 μH~100 μH)

“S” is winding start.

Terminal Pins(1[#]) and (4[#]),(2[#]) and (3[#]) are short connected when used as an inductor.

Type: CMD5D11
◆ Specification

Part No. ※	Stamp	Inductance (μ H) 100kHz/1V	D.C.R.(m Ω) Max.(Typ.) (at 20°C)	Saturation Current (mA) (at 20°C)※1	Temperature Rise current (mA) ※2
CMD5D11NP-3R3M□	3R3	3.3 \pm 20%	109(87)	940	1160
CMD5D11NP-4R7M□	4R7	4.7 \pm 20%	156(125)	800	1060
CMD5D11NP-6R8M□	6R8	6.8 \pm 20%	216(173)	650	900
CMD5D11NP-100M□	100	10 \pm 20%	275(220)	540	830
CMD5D11NP-150M□	150	15 \pm 20%	438(350)	400	580
CMD5D11NP-220M□	220	22 \pm 20%	663(530)	360	540
CMD5D11NP-330M□	330	33 \pm 20%	975(780)	320	430
CMD5D11NP-470M□	470	47 \pm 20%	1380(1150)	260	300
CMD5D11NP-680M□	680	68 \pm 20%	1700(1410)	230	270
CMD5D11NP-101M□	101	100 \pm 20%	2800(2330)	200	200

Terminal Pins(1[#]) and (4[#]),(2[#]) and (3[#]) are short connected when measuring.

※ Description of Part Name

CMD5D11NP-3R3M□

- B Box
- C Carrier Tape

※1.Saturation current: The DC current at which the inductance decreases to 90% of it's initial value.

※2.Temperature rise current: The DC current at which the temperature rise is $\Delta t=40^{\circ}\text{C}$.($T_a=20^{\circ}\text{C}$)

Looking for pricing, stock, or lifecycle information?

Click below to explore more details on WIN SOURCE:

-  [View CMD5D11NP-100MC on WIN SOURCE](#)
-  [Sumida America Components Inc. Information](#)

Optimize Your Supply Chain with WIN SOURCE Solutions

-  Global Sourcing Solution
-  Obsolete Management
-  Cost Control Management
-  Shortage Management
-  Alternative Solution
-  Excess Inventory Management