



**THE DATASHEET OF
RR122-1B13-512**



1 Description

The RedRock® RR122-1B12-511/512 and RR122-1B13-511/512 are digital magnetic sensors ideal for use in medical, industrial, automotive, and consumer applications. It is based on patented Tunneling Magneto-resistance (TMR) technology with seamless CMOS integration.

The RR122-1B12-511/512 and RR122-1B13-511/512 feature an operate sensitivity of 30 G (3 mT), with an omnipolar magnetic field response. They offer a wide supply voltage range from 1.7 up to 5.5 V, ideal for applications ranging from small battery-powered electronics to industrial machinery. They have the world's lowest average current drain (50nA) for an active magnetic sensor, operating at 2 Hz and high operating temperature range from -40°C up to +125°C.

2 Features

- ▶ Operate sensitivity of 30 G
- ▶ Lowest Average Current < 50 nA
- ▶ Wide Supply Voltage range of 1.7V – 5.5V
- ▶ Omnipolar Push-Pull Response
- ▶ Operating Frequency of 2 Hz
- ▶ Temperature Rated up to +125°C
- ▶ RoHS & REACH Compliant

3 Applications

- ▶ Proximity Detection
- ▶ Rotary Sensing
- ▶ Fluid Level Detection
- ▶ Door & Lid Closure Detection
- ▶ Utility Meters
- ▶ Portable Medical Devices
- ▶ Motor Controllers
- ▶ Consumer Electronics
- ▶ Wake-Up μ Processor

Device Information

Part Series	Package	Body Size (mm)	Temp Rating °C
RR122-1B12-511	SOT-23-3	2.9 x 1.6 x 1.2	-40 to +85
RR122-1B12-512	LGA-4	1.45 x 1.45 x 0.44	-40 to +85
RR122-1B13-511	SOT-23-3	2.9 x 1.6 x 1.2	-40 to +125
RR122-1B13-512	LGA-4	1.45 x 1.45 x 0.44	-40 to +125



Device Packages

Functional Block Diagram for Digital Push-Pull Output

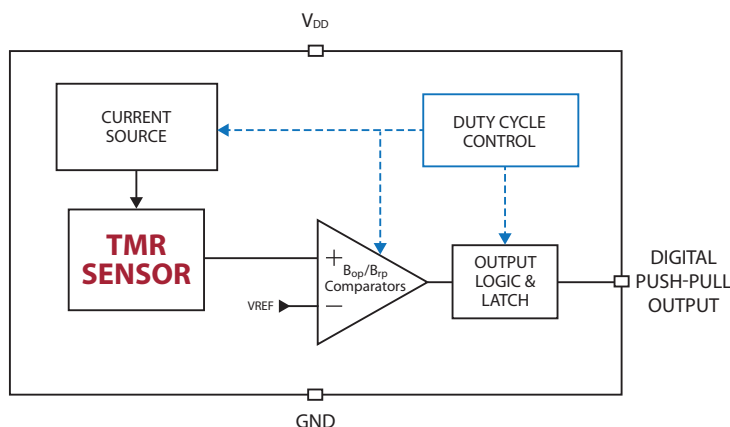

Device Nomenclature

Ordering Information

RR122-X X X X-YYY

Series	Package
Magnetic Polarity Response	1: SOT-23-3
1 = Omnipolar 3 = Bipolar/Latch	2: LGA-4
2 = Unipolar	5: SOT-23-5
Magnetic Sensitivity (G)	Output Response
A: Op 9, Rel 5 E: Op 15, Rel 10	1: Active Low
B: Op 30, Rel 20 F: Op 70, Rel 50	Supply Voltage (V)
C: Op 10, Rel -10	5: 1.7 - 5.5
Clock Frequency (Hz)	Temp Rating (°C)
1: 2 5: 250 9: 10000	2: -40 - +85
2: 10 6: 500 U: 100+Turbo (10000)	3: -40 - +125
3: 20 7: 2500	

4 Specifications

4.1 Absolute Environmental Ratings^{1,2}

Parameters	Units	Min	Typ	Max
Operating Temperature (T_{OP}) (RR122-1B12-511/512)	°C	-40		+85
Operating Temperature (T_{OP}) (RR122-1B13-511/512)	°C	-40		+125
Storage Temperature (T_{STG})	°C	-65		+150
Junction Temperature (T_J)	°C			+150
Soldering Temperature (3 cycles, 1 min.) (T_{SOL})	°C			+260
ESD Level Human Body Model per JESD22-A114	V	±4000		
ESD Level Charged Device Model (CDM) per JESD22-C101	V	±500		
Junction-to-Ambient Thermal Resistance (LGA-4)	°C/W		165	
Junction-to-Ambient Thermal Resistance (SOT-23-3)	°C/W		215	
Maximum Magnetic Field Exposure (B_{MAX})	G			±2000

4.2 Absolute Electrical Ratings^{1,2}

Parameters	Units	Min	Typ	Max
Supply Voltage (V_{DD})	V	-0.3		6.0
Push-pull Output (Active Low)(V_{OUT_PP})	V	-0.3		V_{DD}
Input and Output Current (I_{IN}/I_{OUT})	mA			±20

4.3 Operating Electrical Characteristics for RR122-1B12-511/512 and RR122-1B13-511/512³

Parameters	Units	Min	Typ	Max
Supply Voltage (V_{DD})	V	1.7	3.0	5.5
Power-On Time (t_{ON})($V_{DD} > 1.7$ V)	µs		50	75
Peak Power-On Current	mA			1.4
Output Voltage (High) (V_{OUTH})	V	90% V_{DD}		
Output Voltage (Low) (V_{OUTL})	V			10% V_{DD}
Under Voltage Lockout Threshold Rising V_{DD} ($V_{UVLO-RISE}$)	V		1.60	1.64
Under Voltage Lockout Threshold Falling V_{DD} ($V_{UVLO-FALL}$)	V	1.44	1.53	
Under Voltage Lockout Hysteresis ($V_{UV-HYST}$)	mV		70	
Average Supply Current @ $V_{DD}=1.7$ V, $f_{SW}=2$ Hz (I_{DD_AVG})	nA		50	
Average Supply Current @ $V_{DD}=3.0$ V, $f_{SW}=2$ Hz (I_{DD_AVG})	nA		70	

Notes:

- Exceeding Absolute Ratings may cause permanent damage to the device.
- Unless otherwise specified, all characteristics are measured at 25°C.
- Unless otherwise specified, $V_{DD} = 1.7$ V to 5.5 V, $T_A = -40$ °C to +85°C (1B12), -40°C to +125°C (1B13). Typical values are $V_{DD} = 3.0$ V and $T_A = +25$ °C.



ESD Note: This product uses semiconductors that can be damaged by electrostatic discharge (ESD). When handling, proper ESD precautions should be taken to avoid performance degradation or loss of functionality. Damage due to inappropriate handling is not covered under warranty.

4 Specifications (cont.)

4.4 Operating Characteristics for RR122-1B12-511/512 and RR122-1B13-511/512¹

Parameters	Units	Min	Typ	Max
Switching Frequency (f_{SW})	Hz	1	2	4
Active Mode Time (t_{ACT})	μs		2.6	
Idle Mode Time @ $f_{SW}=2$ Hz (t_{IDLE})	ms	250	500	1000
Operate Point (B_{OPN})	G	23	30	38
Operate Point (B_{OPS})	G	-38	-30	-23
Release Point (B_{RPN})	G	14	20	27
Release Point (B_{RPS})	G	-27	-20	-14
Hysteresis (B_{HYST}) ²	G	5	10	

- Notes:**
- Unless otherwise specified, $V_{DD} = 1.7$ V to 5.5 V, $T_A = -40^\circ\text{C}$ to $+85^\circ\text{C}$ (1B12), -40°C to $+125^\circ\text{C}$ (1B13). Typical values are $V_{DD} = 3.0$ V and $T_A = +25^\circ\text{C}$.
 - Conditions: $B_{HYST} = |B_{OP} - B_{RP}|$
-  ESD Note: This product uses semiconductors that can be damaged by electrostatic discharge (ESD). When handling, proper ESD precautions should be taken to avoid performance degradation or loss of functionality. Damage due to inappropriate handling is not covered under warranty.

5 Magnetic Response

For more information please contact Coto Technology at RedRock@cotorelay.com.

5.1 Axis of Sensitivity

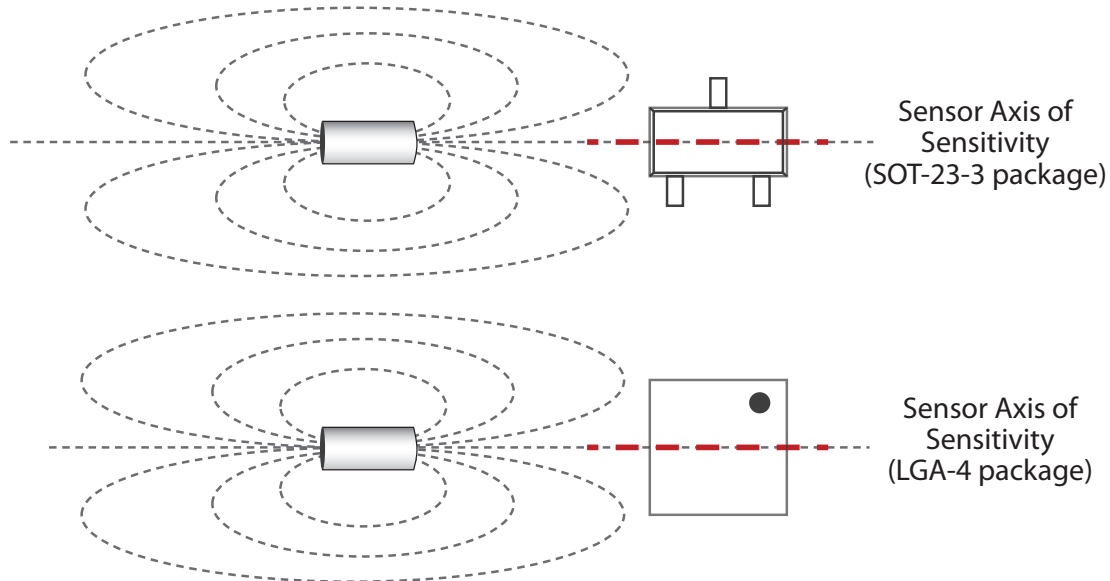

Note: The most straightforward way of aligning a magnet with a TMR sensor is by lining up the magnet's magnetization axis with the sensor's Axis of Sensitivity (as shown above). However, there are many other alignments and orientations that will also achieve proper operation. For any questions, or to learn more, please contact Coto Technology.

5 Magnetic Response (cont.)

5.2 Magnetic Response Table (SOT-23-3 package)

Scenario	Step 1: Sensor is powered without magnetic field.	Step 2: Magnet applied, polarity North .	Step 3: Magnet removed.	Step 4: Magnet applied, polarity South .	Step 5: Magnet removed.
OMNIPOLAR SENSOR OUTPUT	HIGH	LOW (Activated)	HIGH	LOW (Activated)	HIGH

5.3 Magnetic Response Table (LGA-4 package)

Scenario	Step 1: Sensor is powered without magnetic field.	Step 2: Magnet applied, polarity North .	Step 3: Magnet removed.	Step 4: Magnet applied, polarity South .	Step 5: Magnet removed.
OMNIPOLAR SENSOR OUTPUT	HIGH	LOW (Activated)	HIGH	LOW (Activated)	HIGH

5.4 Magnetic Response Output Diagram

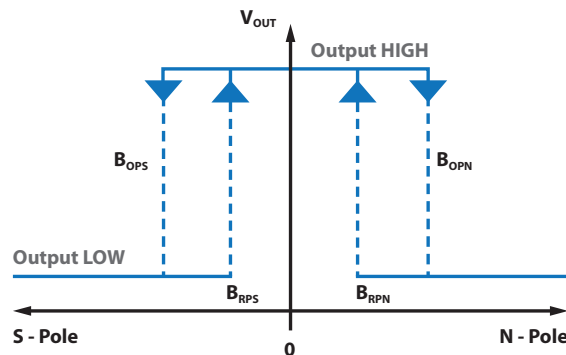

6 Application Information

RR122 Push-Pull Output Application Circuit

The output voltage on the RR122 is active low, meaning that while a sufficiently strong magnetic field is present, the output voltage is low. The output voltage can be connected to a digital input pin on a microcontroller. A decoupling capacitor between the supply voltage and ground is required with placement close to the magnetic sensor. A capacitor with a value of $1\ \mu\text{F}$, placed not more than 10 mm from the sensor, is required.

6.1 Application Circuit (SOT-23-3)

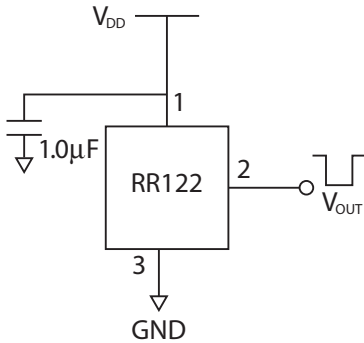

6.2 Application Circuit (LGA-4)

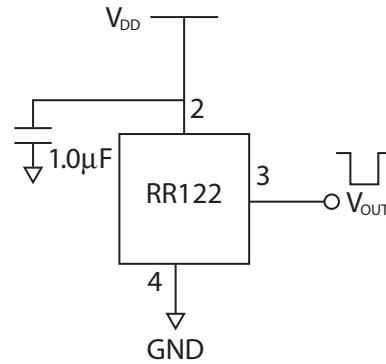

6.3 Package Pinout (SOT-23-3)

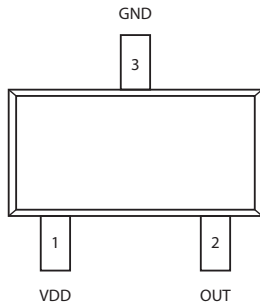

6.4 Package Pinout (LGA-4)

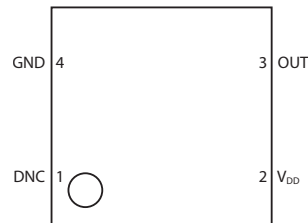

7 Dimensions *Millimeters (Inches)*

8.1 SOT-23-3 Package

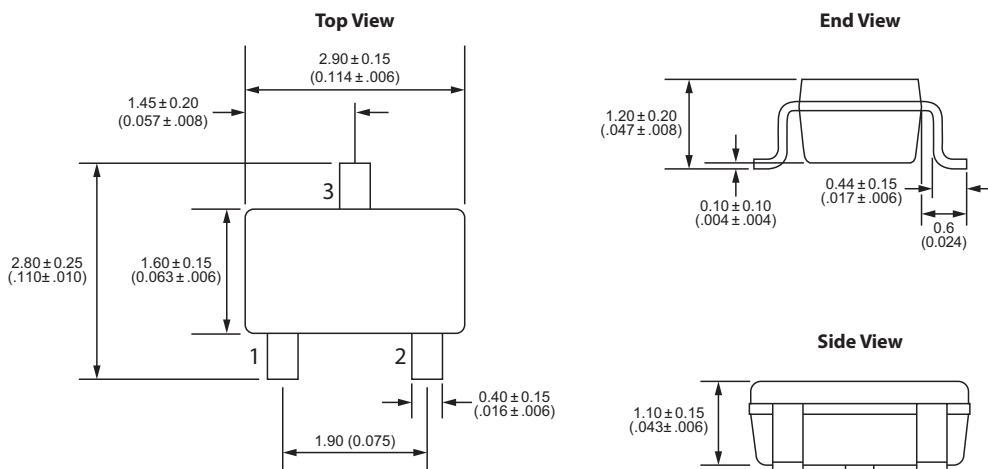

7 Dimensions *Millimeters (Inches)*

8.2 LGA-4 Package

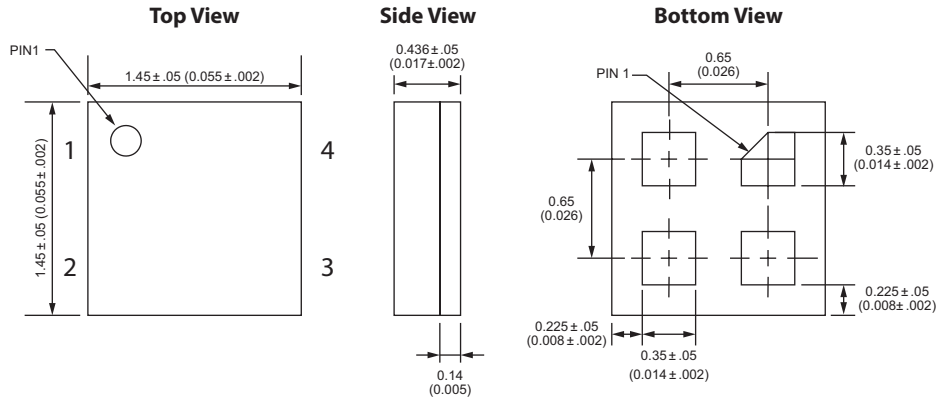

8 TMR Sensor Location

8.1 SOT-23-3 Package

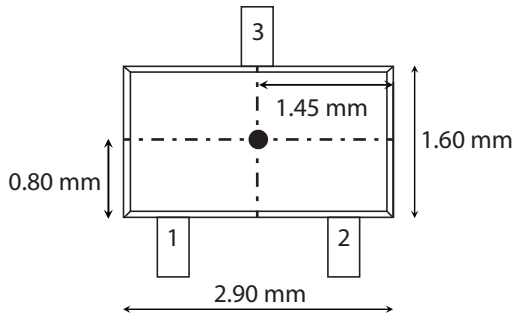

8.2 LGA-4 Package

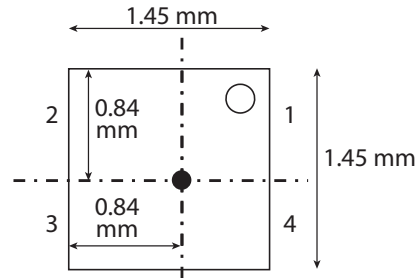

8.3 SOT Package - Side View

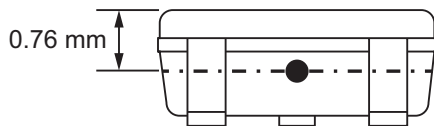

8.4 LGA Package - Side View

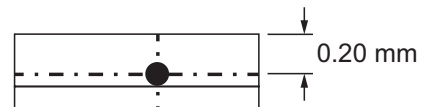

9 TMR Sensor & Switch Packaging

9.1 SOT-23-3 Tape & Reel Packaging

Standard packaging is Tape & Reel containing 3,000 pieces. MSL Rating is 1.

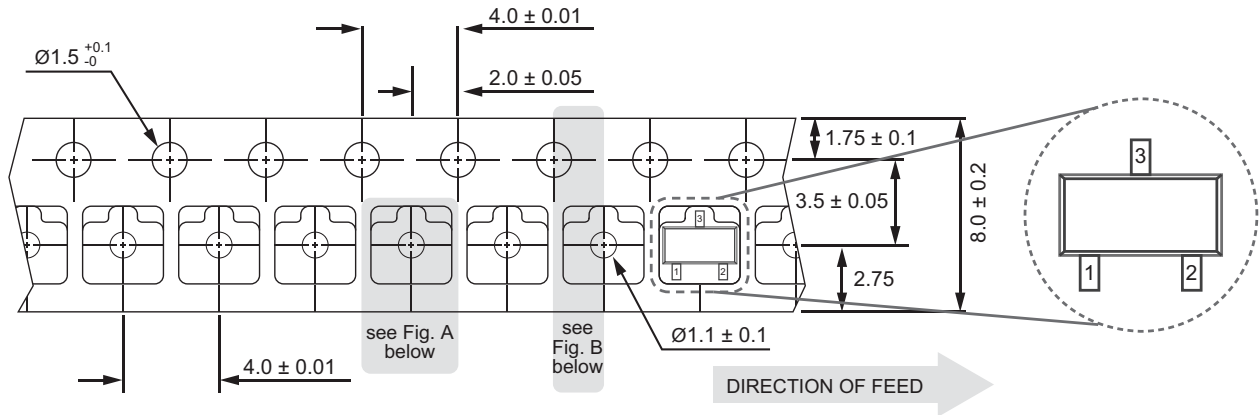

Fig. A

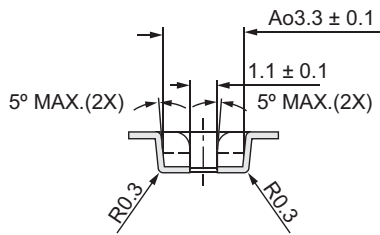
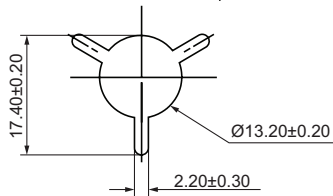
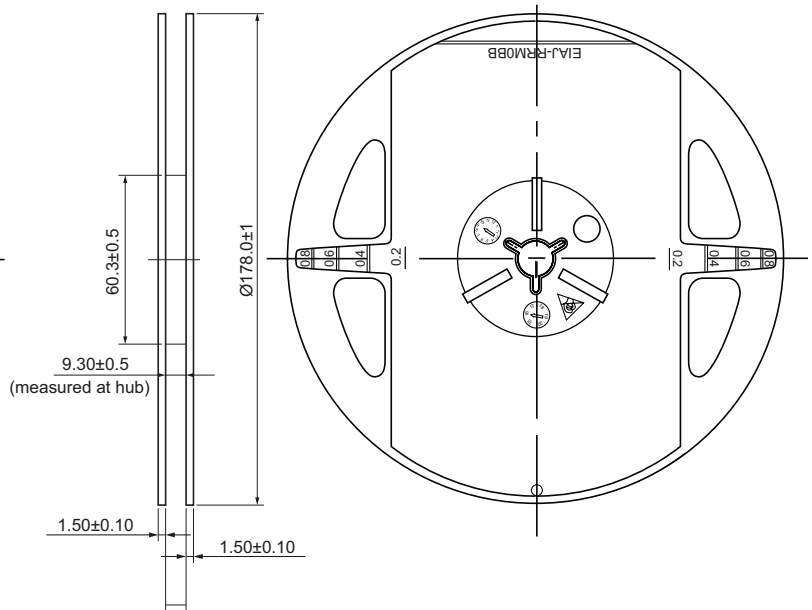
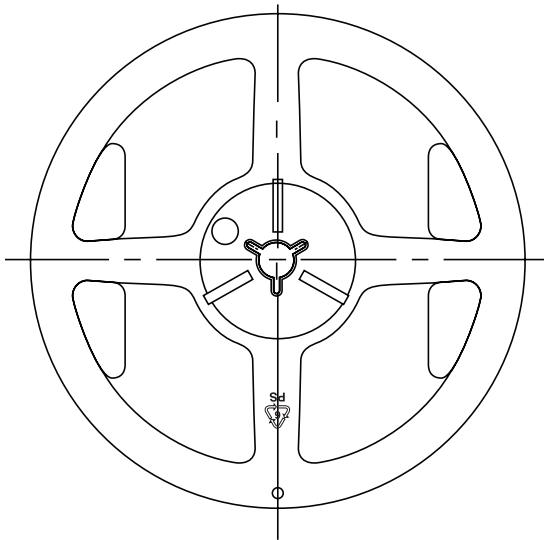
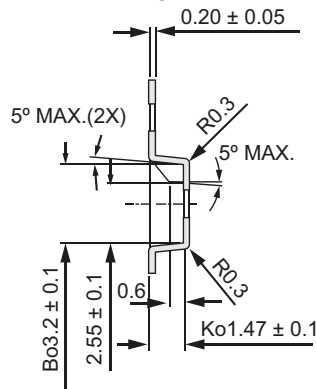

Fig. B



9 TMR Sensor & Switch Packaging

9.2 LGA-4 Tape & Reel Packaging

Standard packaging is Tape & Reel containing 3,000 pieces. MSL Rating is 3.

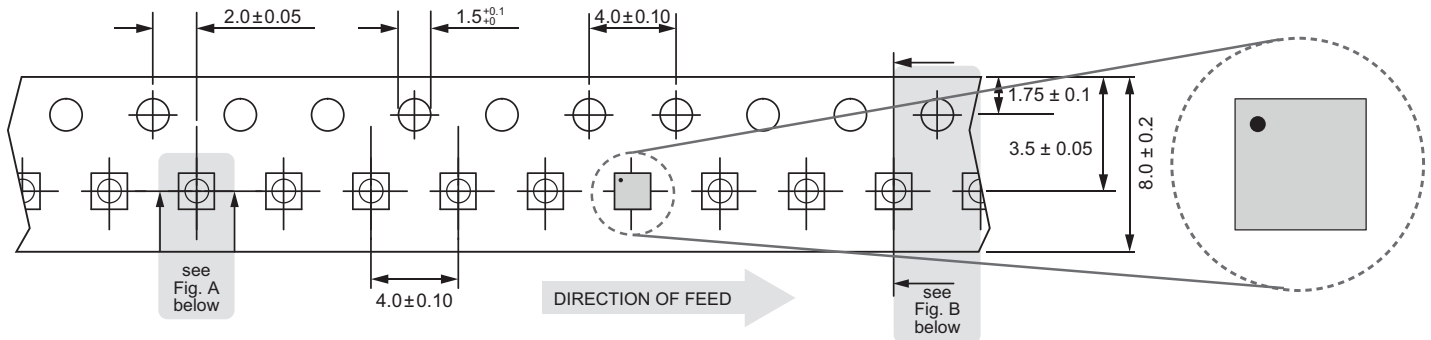

Fig. A

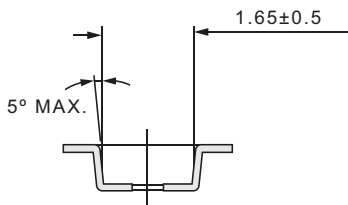
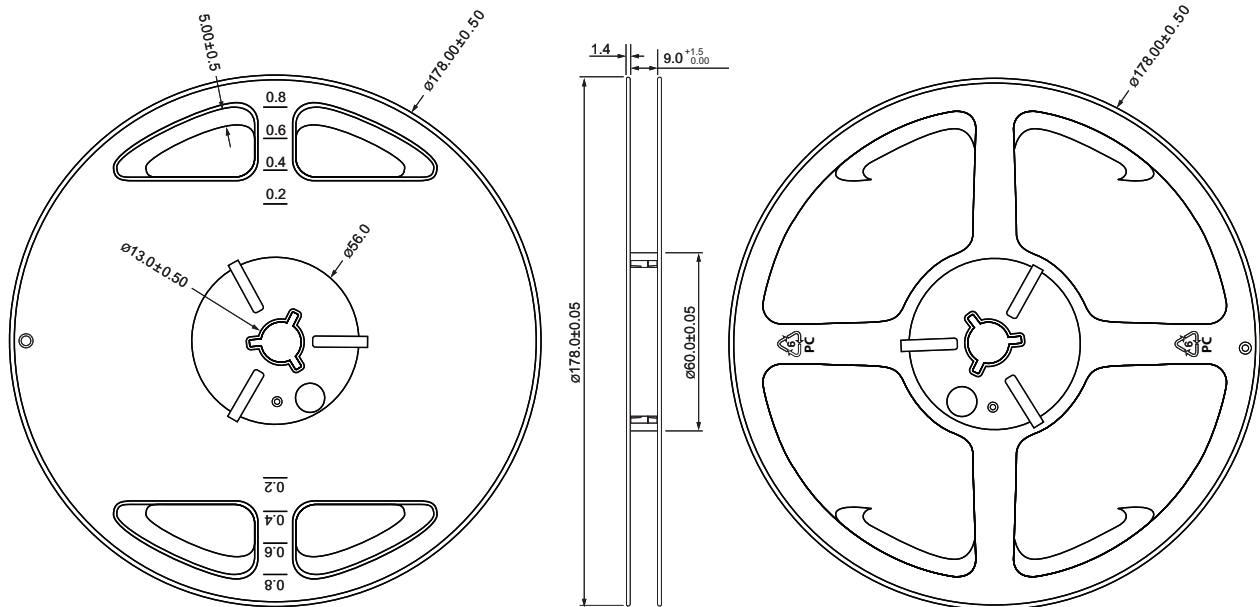
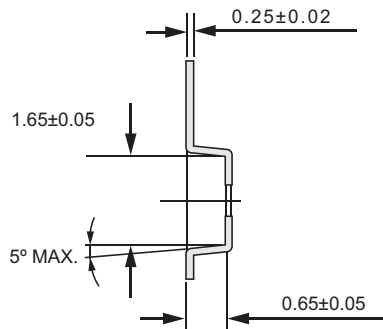

Fig. B



9 TMR Sensor & Switch Packaging

9.3 RedRock Package Codes

RR122-1B12-511 / RR122-1B13-511 (SOT-23-3)

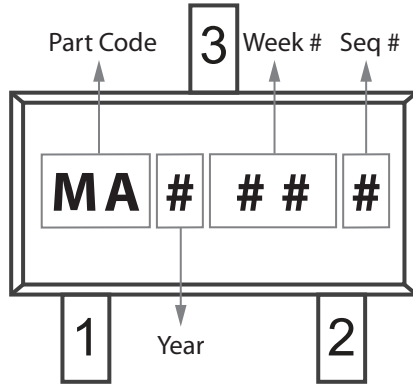

RR122-1B12-512 / RR122-1B13-512 (LGA-4)

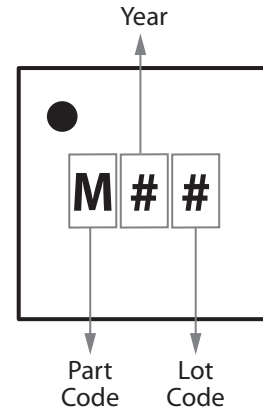

9.4 RedRock TMR Packaging

Box Dimensions – 14x10x6 inches

- Fits 1 to 3 reels = 3000 to 9000 pcs
- Weight for 3000 pcs = 0.90 kilos
- Weight for 9000 pcs = 1.00 kilos

Box Dimensions – 18x14x12 inches

- Fits 4 to 24 reels = 12000 to 72000 pcs
- Weight for 12000 pcs = 1.50 kilos
- Weight for 72000 pcs = 4.90 kilos

10 Suggested Pb-Free Reflow Profile

- Notes:**
1. Fully compatible with standard no-lead solder profile, 260°C for 30 seconds max (3 cycles max).
 2. Profile shown as example. Users are advised to develop their own board-level profile.
 3. Suggested Pb-free reflow profile derived from IPC/JEDEC J-STD-020E.
 4. Temperature tolerance: +0°C, as measured at any point on the package or leads
 5. MSL rating of 1 (SOT-23-3 only) compatible with J-STD-020 or equivalent.
 6. MSL rating of 3 (LGA-4 and Leaded LGA-4) compatible with J-STD-020 or equivalent.
 7. All temperatures refer to the center of the package, measured on the package body surface that is facing up during assembly reflow (e.g., live-bug). If parts are reflowed in other than the normal live bug assembly reflow orientation (i.e., dead-bug), T_p shall be within $\pm 2^\circ\text{C}$ of the live bug T_p and still meet the T_c requirements, otherwise, the profile shall be adjusted to achieve the latter. To accurately measure actual peak package body temperatures, refer to JEP140 for recommended thermocouple use.
 8. Reflow profiles in this document are for classification/preconditioning and are not meant to specify board assembly profiles. Actual board assembly profiles should be developed based on specific process needs and board designs and should not exceed the parameters in this table.

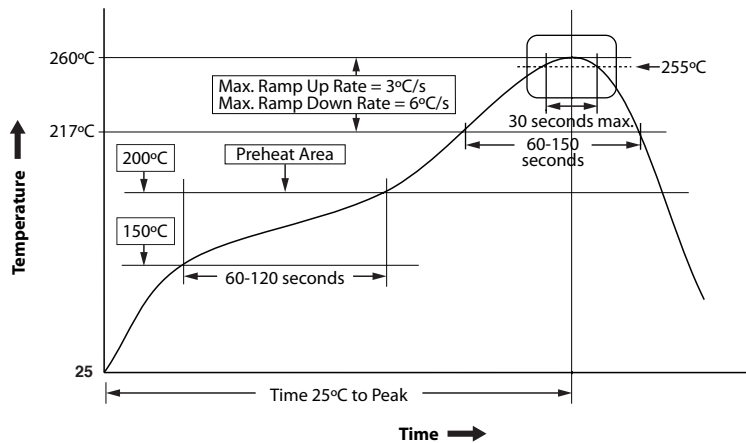

11 Suggested Solder Pad Layout

Dimensions in mm (inches)

13.1 SOT-23-3 Solder Pad Layout

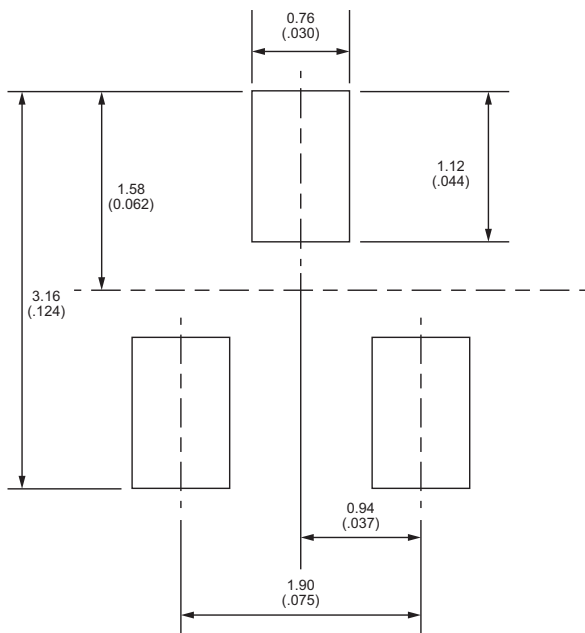

13.2 LGA-4 Solder Pad Layout

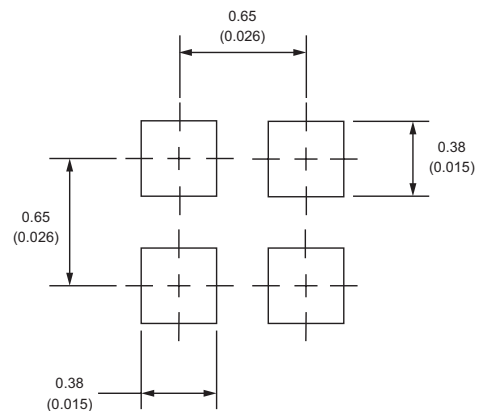

12 Graphs - Typical Electrical Characteristics

$C_{DD} = 1.0 \mu\text{F}$ (unless otherwise specified)

**12.1 RR122-1B12-511 / 512
 Average Supply Current vs.
 Supply Voltage vs. Temperature**

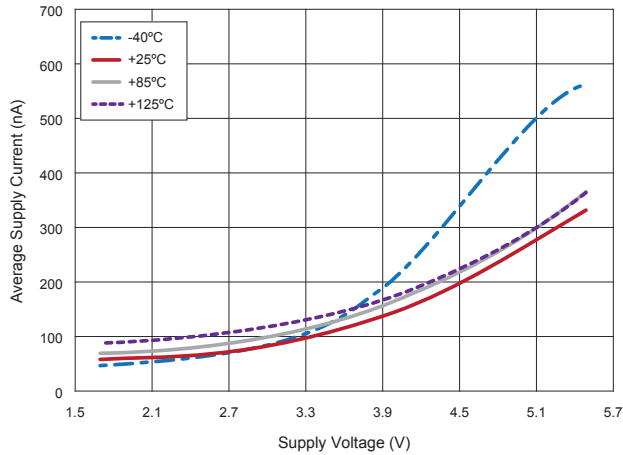

**12.2 RR122-1B12-511 / 512
 Average Supply Current vs.
 Temperature vs. Supply Voltage**

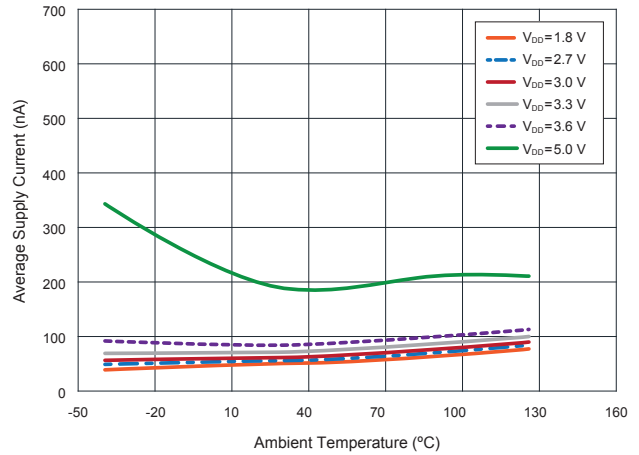

**12.3 RR122-1B12-511 / 512
 Sampling Frequency vs.
 Supply Voltage vs. Temperature**

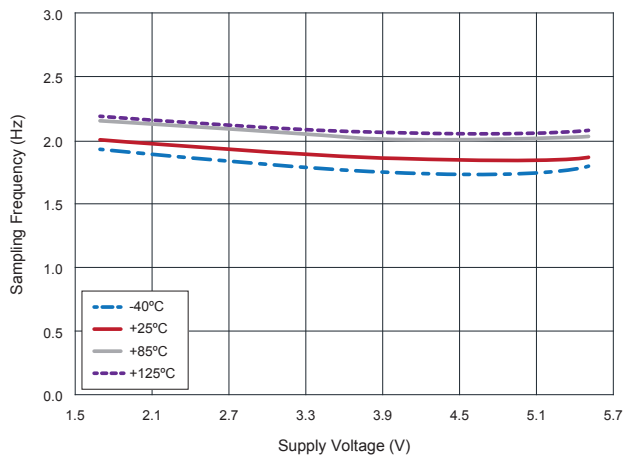

12 Graphs - Typical Magnetic Characteristics

$C_{DD} = 1.0 \mu\text{F}$ (unless otherwise specified)

12.4 RR122-1B12-511 / 512
 B_{OPN} (Blue) and B_{OPS} (Red) vs.
Supply Voltage at +25°C

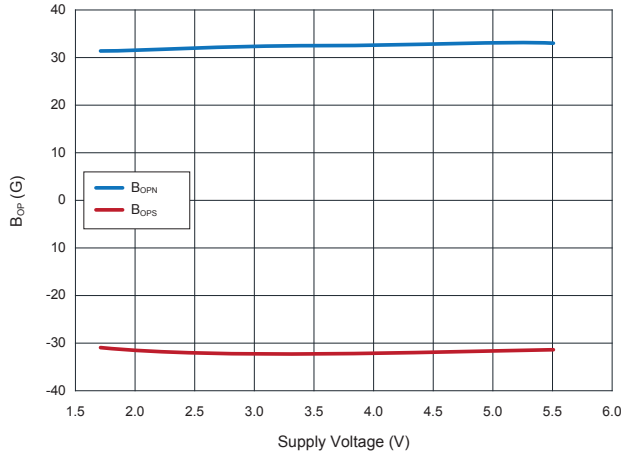

12.5 RR122-1B12-511 / 512
 B_{RPN} (Blue) and B_{RPS} (Red) vs.
Supply Voltage at +25°C

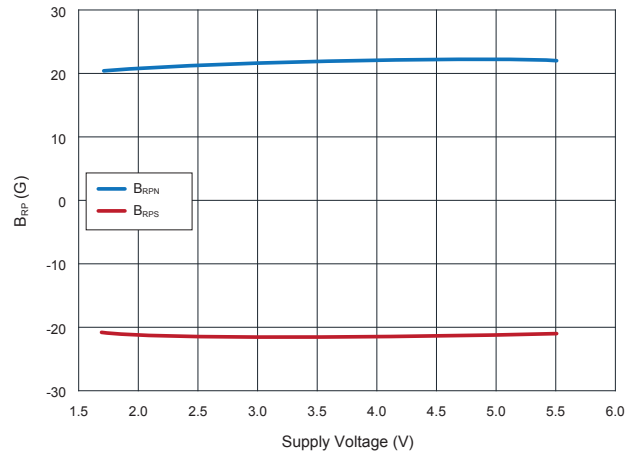

12.6 RR122-1B12-511 / 512
 B_{OPN} (Blue) and B_{OPS} (Red) vs.
Operating Temperature at $V_{DD}=3.0\text{ V}$

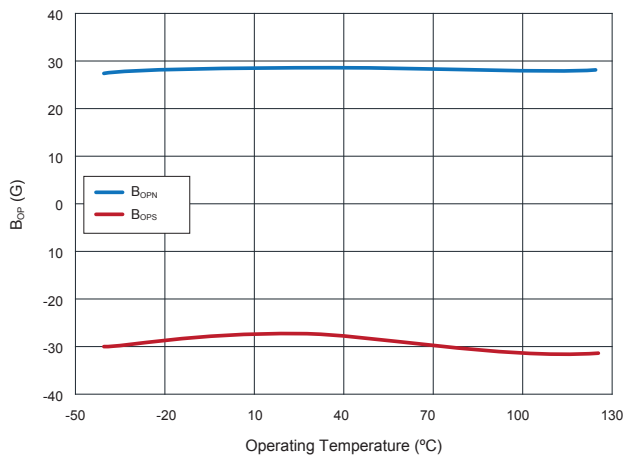

12.7 RR122-1B12-511 / 512
 B_{RPN} (Blue) and B_{RPS} (Red) vs.
Operating Temperature at $V_{DD}=3.0\text{ V}$

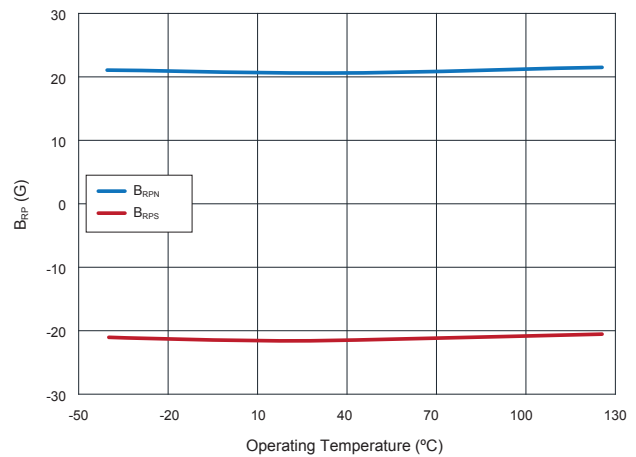

Revision History

	Date	Description
1	10/13/2020	Added Maximum Magnetic Field Exposure Value (Table 4.1)
2	10/13/2020	Modified Input and Output Current (Table 4.2)
3	10/13/2020	Modified UVLO Rise Value (Table 4.3)
4	10/13/2020	Modified UVLO Fall Value (Table 4.3)
5	10/13/2020	Added Supply Voltage, Typical (Table 4.3)
6	10/13/2020	Modified Active Mode Time Value (Table 4.4)
7	10/13/2020	Added MIN & MAX Values to Idle Mode (Table 4.4)
8	10/13/2020	Modified Operate Point (BopN) MIN Value (Table 4.4)
9	10/13/2020	Modified Operate Point (BopS) MAX Value (Table 4.4)
10	10/13/2020	Modified Hysteresis MIN Value (Table 4.4)
11	10/14/2020	Modified Supply Voltage MAX Value (Table 4.2)
12	10/15/2020	Added Idd _{AVG} MAX Value (Table 4.3)
13	09/14/2021	Modified Axis of Sensitivity on LGA-4 Package (Section 7.2)
14	10/29/2021	Modified Bottom View Dimensions (Section 8.2 LGA-4 Package)
15	12/14/2021	Corrected misleading elements in Table 4.3
16	02/28/2022	Revised/expanded Magnetic Response Section (Section 5)
17	02/28/2022	Removed sections 7 and 10, consolidating information within new Section 5
18	02/28/2022	Modified packaging drawings (9.1 and 9.2)
19	02/28/2022	Modified LGA Sensor Location package drawings (8.2 and 8.4)
20	02/28/2022	Added RedRock Package Code section (9.3)
21	03/04/2022	Added Package Pinouts (Section 6)
22	03/04/2022	Modified Power On Time (Table 4.3)
23	03/08/2022	Added ESD Level Charged Device Model (Table 4.1)
24	03/08/2022	Modified Under Voltage Lockout Hysteresis (Table 4.3)

Looking for pricing, stock, or lifecycle information?

Click below to explore more details on WIN SOURCE:

 [View RR122-1B13-512 on WIN SOURCE](#)

 [Coto Technology](#) Information

Optimize Your Supply Chain with WIN SOURCE Solutions

-  Global Sourcing Solution
-  Obsolete Management
-  Cost Control Management
-  Shortage Management
-  Alternative Solution
-  Excess Inventory Management