



**THE DATASHEET OF
TFA9872AUK/N1Z**



TFA9872_SDS

High Efficiency Class-D Audio Amplifier with Speaker-as-Microphone

Rev. 1 — 12 April 2017

Product short data sheet
COMPANY PUBLIC

1 General description

The TFA9872 is a 9.5 V boosted class-D audio amplifier featuring Speaker-as-Microphone (SaM) and Receiver-as-Microphone (RaM) modes. It can deliver up to 10.0 W peak output power into an 8 Ω speaker and up to 11.8 W peak output power into a 6 Ω speaker, at a supply voltage of 4.0 V. The internal adaptive DC-to-DC converter raises the supply voltage to 9.5 V, providing ample headroom for major improvements in sound quality.

Internal adaptive DC-to-DC conversion boosts the supply rail to provide additional headroom and power output. The supply voltage is only raised when necessary, maximizing the output power of the class-D audio amplifier while limiting quiescent power consumption.

The device can be configured to drive either a hands-free speaker (4 Ω to 8 Ω) for audio playback, or a receiver speaker (32 Ω) for handset playback, allowing it to be embedded in platforms that support either or both options. The maximum output power, gain, and noise levels are lower in the Handset Call use case than in the Hands-free Call use case.

The SaM feature allows the speaker to be used as an additional microphone when not configured for audio playback. This function performs best in high sound pressure environments (like concert recording or wind noise calls) and is targeted at such use cases.

The TFA9872 also incorporates battery protection. By limiting the supply current when the battery voltage is low, the device is prevented from switching off unexpectedly due to excessive load currents (excessive load currents can lead to a system undervoltage).

Because it has a digital input interface that is insensitive to clock jitter, the TFA9872 features low RF susceptibility. The second order closed loop architecture used in a class-D audio amplifier provides excellent audio performance and high supply voltage ripple rejection. The audio input interface is I²S and the control settings are communicated via an I²C-bus interface.

The TFA9872 is available in a 42-bump WLCSP (Wafer Level Chip-Size Package) with a 400 μ m pitch.



2 Features and benefits

- High output power: 5.1 W (average) into 8 W at 4.0 V supply voltage (THD = 1 %)
- Supports handset (16 Ω or 32 Ω) and hands-free (4 Ω or 8 Ω) speaker configurations
- High efficiency, low power dissipation and low-noise speaker driver
- Adaptive DC-to-DC converter increases the supply voltage smoothly when switching between fixed boost and adaptive boost modes, preventing large battery supply spikes and limiting quiescent power consumption.
- Wide supply voltage range (fully operational from 2.7 V to 5.5 V)
- Very low noise output <20×mV (with null data input at $F_s = 48$ kHz)
- Low battery current consumption <130 mA ($P_o = 380$ mW, average music power)
- I²C-bus control interface (400 kHz)
- Speaker current and voltage monitoring (via the I²S-bus) for Acoustic Echo Cancellation (AEC) at the host
- 16 kHz /44.1 kHz/48 kHz sample frequencies supported
- Ultrasonic support (limited) via TDM/I²S running at 96 kHz/192 kHz
- Configurable full-duplex 4-wire TDM/I²S input interface supporting up to 16 slots
- Low-latency input path supporting side tone mixing via dedicated PDM input interface
- Speaker-as-Microphone feedback path on dedicated PDM output interface or TDM interface
- Programmable interrupt control via a dedicated interrupt pin
- Low RF susceptibility
- Thermal foldback and overtemperature protection
- 15 kV system-level ESD protection without external components on amplifier output

3 Applications

- Mobile phones & Tablets
- Portable Navigation Devices (PND)
- Notebooks/Netbooks
- Internet of Things applications embedding high-quality audio

4 Quick reference data

Table 1. Quick reference data

Symbol	Parameter	Conditions	Min	Typ	Max	Unit
V _{BAT}	battery supply voltage	on pin VBAT V _{BAT} must not be lower than V _{DDD} or V _{DDE} in application	2.7	-	5.5	V
V _{DDD}	digital supply voltage	on pin VDDD	1.65	1.8	1.95	V
V _{DD(IO)}	input/output supply voltage	on pin VDDE	1.65	1.8	1.95	V
I _{BAT}	battery supply current	Active state on pin VBAT; Operating mode with load; R _L = 6 Ω; DC-to-DC converter in Adaptive Boost mode; P _o = 380 mW (average music power); V _{BAT} = 4.0 V; V _{DDP} = 8.5 V	-	122	-	mA
		Idle state on pin VBAT; Operating mode with load; R _L = 6 Ω and no output signal (idle); DC-to-DC converter in Adaptive Boost mode; V _{BAT} = 4.0 V; V _{DDP} = 8.5 V	-	1.8	-	mA
		Power-down state on pin VBAT; DC-to-DC converter in power-down mode; T _j = 25 °C; no clock	-	1	-	μA
I _{DDD}	digital supply current	Active state on pin VDDD; Operating mode with load; R _L = 6 Ω; DC-to-DC converter in Adaptive Boost mode, P _o = 380 mW (average music power), V _{BAT} = 4.0 V; V _{DDP} = 8.5 V	-	6.8	-	mA
		Idle state on pin VDDD; Operating mode with load; R _L = 6 Ω and no output signal (idle); DC-to-DC converter in Adaptive Boost mode; V _{BAT} = 4.0 V; V _{DDP} = 8.5 V	-	4.1	-	mA
		Power down state on pin VDDD; DC-to-DC converter in power-down mode; T _j = 25 °C; no clock	-	10	-	μA
P _{O(AVG)}	average output power	THD+N = 1 %; L _L = 44 μH; V _{BAT} = 4.0 V; V _{DDD} = 1.8 V				
		V _{BST} = 9.5 V; R _L = 8 Ω	-	5.1	-	W
		V _{BST} = 8.5 V; R _L = 8 Ω	-	4.0	-	W
		V _{BST} = 9.5 V; R _L = 6 Ω	-	5.9	-	W
		V _{BST} = 8.5 V; R _L = 6 Ω	-	5.1	-	W
SaM S/N	speaker-as-microphone signal-to-noise ratio	A-weighted; PDM output; full scale input; PGA gain setting GAIN_10	-	78.6	-	dB

5 Ordering information

Table 2. Ordering information

Type number	Package		Version
	Name	Description	
TFA9872AUK/N1	WLCSP42	wafer level chip-scale package; 42 bumps; 3.13 × 2.46 × 0.50 mm	SOT1459-2
TFA9872CUK/N1	WLCSP42	wafer level chip-scale package; 42 bumps; 3.13 × 2.46 × 0.525 mm	SOT1459-2

6 Block diagram

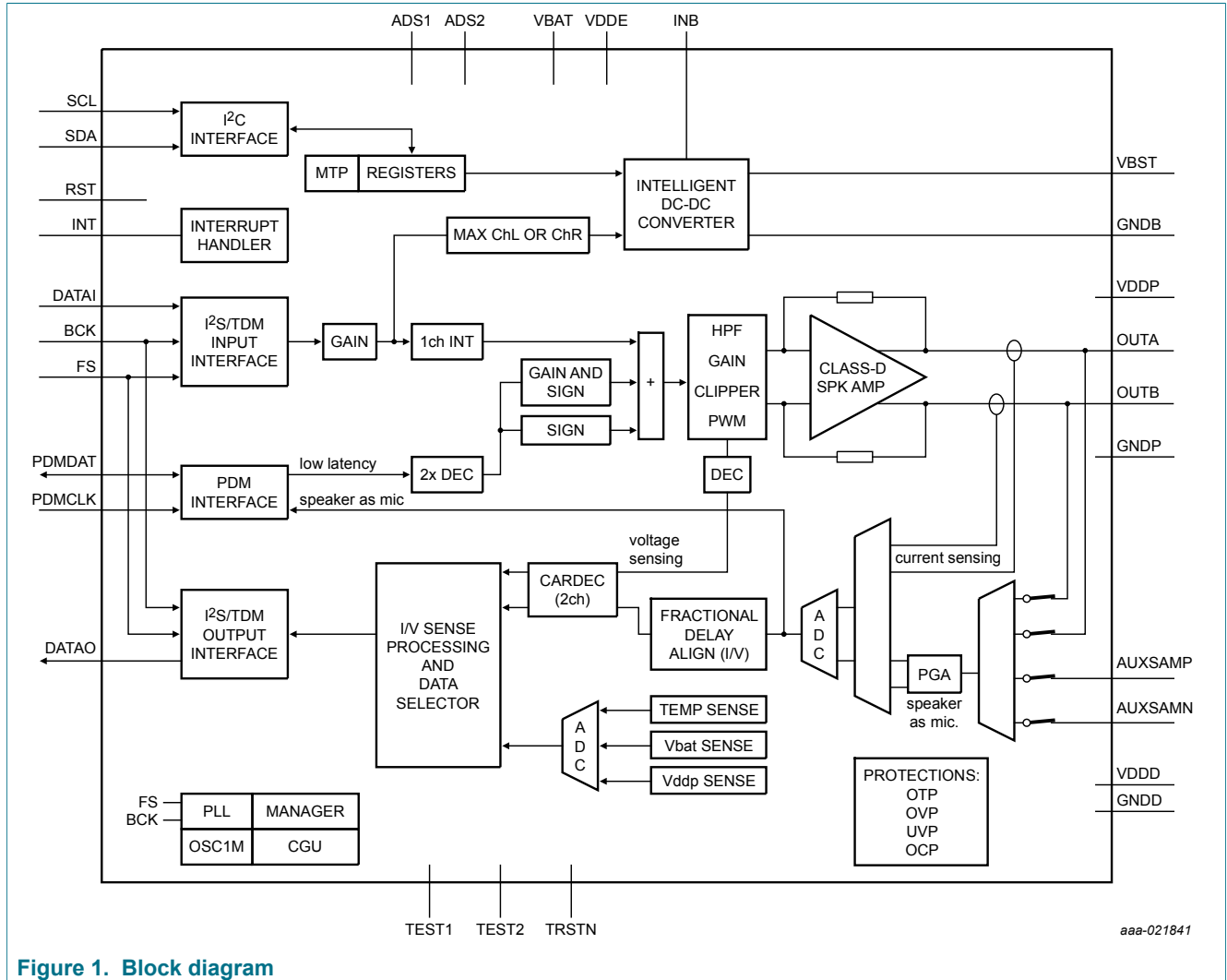

Figure 1. Block diagram

7 Pinning information

7.1 Pinning

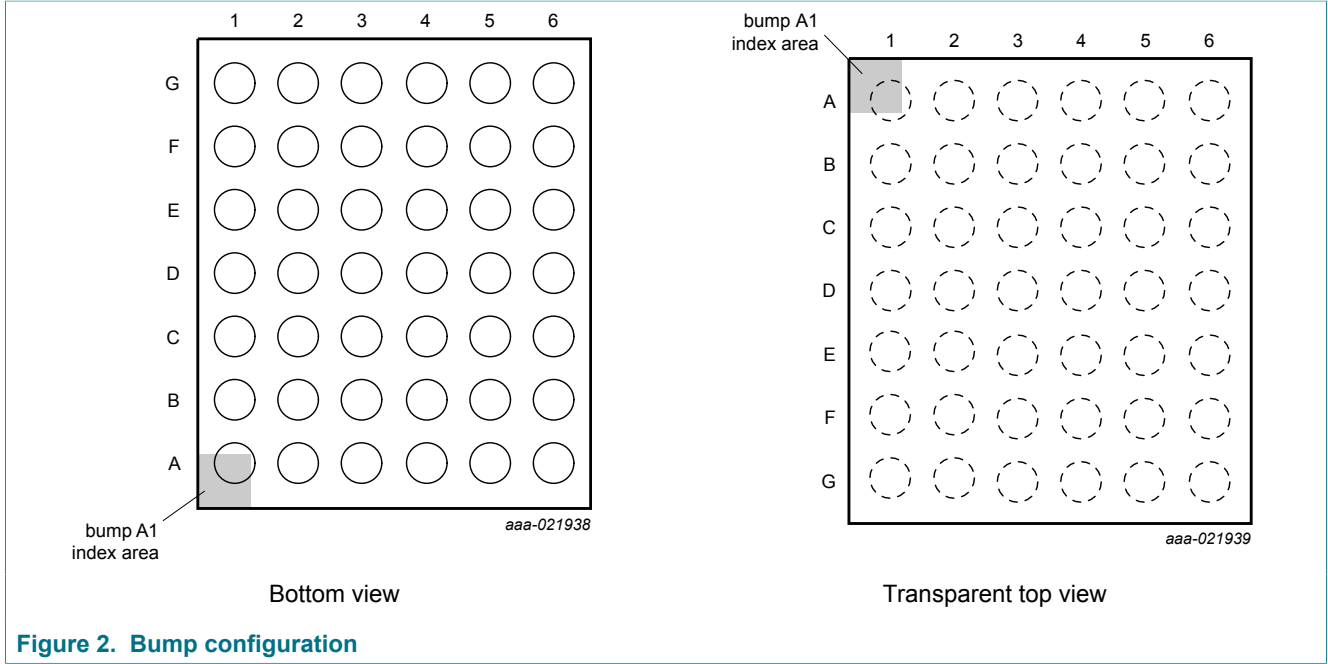

Figure 2. Bump configuration

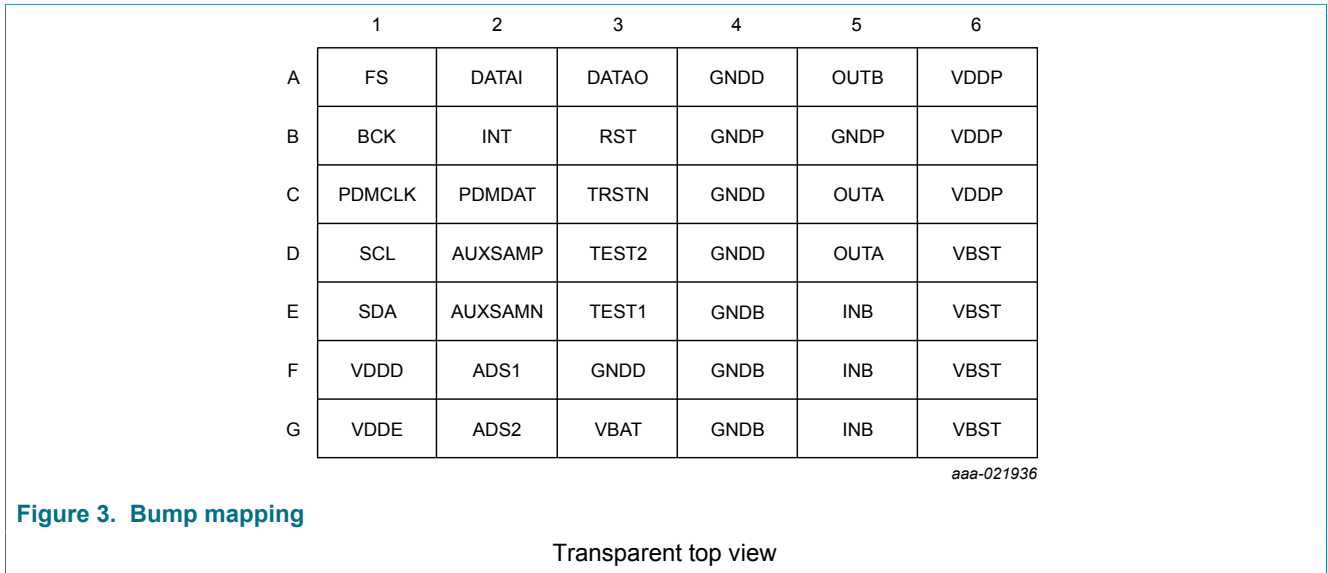

Figure 3. Bump mapping

Transparent top view

7.2 Pin description

Table 3. Pinning

Symbol	Pin	Type	Description
FS	A1	I	digital audio frame sync for TDM/I ² S interface
DATAI	A2	I	digital audio data input for TDM/I ² S interface
DATAO	A3	O	digital audio data output for TDM/I ² S interface
GNDD	A4	P	digital ground
OUTB	A5	O	inverting output
VDDP	A6	P	power supply voltage
BCK	B1	I	digital audio bit clock input for TDM/I ² S interface
INT	B2	O	digital interrupt output
RST	B3	I	digital reset input
GNDD	B4	P	power ground
GNDD	B5	P	power ground
VDDP	B6	P	power supply voltage
PDMCLK	C1	I	digital audio clock for PDM interface
PDMDAT	C2	I	digital audio data for PDM interface
TRSTN	C3	I	test reset signal (for JTAG); connect to PCB ground
GNDD	C4	P	digital ground
OUTA	C5	O	non-inverting output
VDDP	C6	P	power supply voltage
SCL	D1	I	digital I ² C-bus clock input
AUXSAMP	D2	I/O	auxiliary speaker-as-microphone non-inverting input
TEST2	D3	I/O	test signal input 2; for test purposes only, connect to PCB ground
GNDD	D4	P	digital ground
OUTA	D5	O	non-inverting output
VBST	D6	O	boosted supply voltage output
SDA	E1	I	digital I ² C-bus data input
AUXSAMN	E2	I/O	auxiliary speaker-as-microphone inverting input
TEST1	E3	I/O	test signal input 1; for test purposes only, connect to PCB ground
GNDB	E4	P	boosted ground
INB	E5	P	DC-to-DC boost converter input
VBST	E6	O	boosted supply voltage output
VDDD	F1	P	digital supply voltage
ADS1	F2	I	digital address select input 1
GNDD	F3	P	digital ground
GNDB	F4	P	boosted ground

Symbol	Pin	Type	Description
INB	F5	P	DC-to-DC boost converter input
VBST	F6	O	boosted supply voltage output
VDDE	G1	P	digital IO supply voltage
ADS2	G2	I	digital address select input 2
VBAT	G3	P	battery supply voltage
GNDDB	G4	P	boosted ground
INB	G5	P	DC-to-DC boost converter input
VBST	G6	O	boosted supply voltage output

8 Functional description

The TFA9872 is a highly efficient Bridge Tied Load (BTL) class-D audio amplifier embedding Speaker-as-Microphone (SaM) support, as depicted in the block diagram of [Figure 1](#).

The TFA9872 contains a TDM/I²S input/output interface for communicating with the audio host. The maximum number of slots is 16 (at $f_s = 48$ kHz) and the minimum number is 2 (I²S mode). The interface is compliant with all I²S interface configurations and supports a wide range of TDM interface configurations. It also features an optional ultrasonic path to the speaker.

The TFA9872 features a slave-configurable IN or OUT PDM interface. This audio interface can be connected to the audio host to provide a low-latency path (for side tone mixing) to the speaker. The 1-bit PDM stream is decimated and applied to the TDM interface. The PDM stream can, optionally, be attenuated or amplified by the gain module. Soft mute control prevents pop and click noise occurring when this signal path is switched on or off. The PDM output also provides a SaM stream back to the host.

At low battery voltage levels, the gain is automatically reduced to limit battery current (when battery safeguard is enabled).

The digital audio stream is converted into two PWM signals which are then injected into the class-D audio amplifier. The 3-level PWM scheme supports filterless speaker drive.

An adaptive DC-to-DC converter boosts the battery supply voltage when the audio stream crosses two programmable voltage thresholds. It switches automatically to Follower mode ($V_{BST} = V_{BAT}$; no boost) when the audio output voltage is lower than the battery voltage.

The SaM feature is available in both PDM and I²S modes. This function can be used to turn the speaker into a dynamic microphone, providing an output audio stream on the digital interfaces. Due to the nature of the speaker membrane, the microphone equivalent characteristics perform best in high Sound Pressure Level (SPL) environments. Consequently, this feature is targeted at specific use cases such as concert recording or calls affected by wind noise. It is not intended to replace a primary/standard microphone but rather to complement it in such use cases by providing a signal that is less sensitive to saturation.

For SaM, a dedicated PGA is used to amplify the weak signal coming from the main speaker or receiver speaker. The result is a microphone that can handle high SPL environments.

SaM can be enabled on the main speaker connected to OUTA/OUTB, when the amplifier is off. Alternatively, SaM can be enabled on auxiliary inputs AUXSAMP/AUXSAMN, with the receiver speaker connected as input.

9 Limiting values

Table 4. Limiting values

In accordance with the Absolute Maximum Rating System (IEC 60134).

Symbol	Parameter	Conditions	Min	Max	Unit
V _x	voltage on pin x	on pin VBAT	-0.3	+6	V
		on pins VBST, VDDP, AUXSAMP, AUXSAMN	-0.3	+12	V
		on pin INB, OUTA, OUTB	-0.3	+12 ^[1]	V
		on pins VDDD, VDDE, TEST1, TEST2	-0.3	+2.5	V
T _j	junction temperature		-40	+150	°C
T _{stg}	storage temperature		-55	+150	°C
T _{amb}	ambient temperature		-40	+85	°C
V _{ESD}	electrostatic discharge voltage	according to Human Body Model (HBM)	-2	+2	kV
		according to Charge Device Model (CDM)	-500	+500	V

[1] Using an NXP demo board with a 1 mm wire/PCB track length on pin INB, AC pulses up to 18 V and -9 V can be observed without causing any damage as these spikes only partly penetrate the device (which is protected by internal clamp circuits).

10 Thermal characteristics

Table 5. Thermal characteristics

Symbol	Parameter	Conditions	Typ	Unit
R _{th(j-a)}	thermal resistance from junction to ambient	4-layer application board	36	K/W

11 Characteristics

11.1 DC Characteristics

Table 6. DC characteristics

All parameters guaranteed for $V_{BAT} = 3.6\text{ V}$; $V_{DDD} = 1.8\text{ V}$; $V_{DDP} = V_{BST} = 9.0\text{ V}$; Adaptive Boost mode; $L_{BST} = 1\text{ }\mu\text{H}^{[1]}$; $R_L = 8\text{ }\Omega^{[1]}$; $L_L = 44\text{ }\mu\text{H}^{[1]}$; $f_i = 1\text{ kHz}$; $f_s = 48\text{ kHz}$; $T_{amb} = 25\text{ }^\circ\text{C}$; default settings, unless otherwise specified.

Symbol	Parameter	Conditions	Min	Typ	Max	Unit
V_{BAT}	battery supply voltage	on pin V_{BAT} V_{BAT} must not be lower than V_{DDD} or V_{DDE} in application	2.7	-	5.5	V
I_{BAT}	battery supply current	Active state on pin V_{BAT} ; Operating mode with load $R_L = 6\text{ }\Omega$; DC-to-DC in Adaptive Boost mode; $P_o = 380\text{ mW}$, (average music power), $V_{BAT} = 4.0\text{ V}$, $V_{DDP} = 8.5\text{ V}$	-	122	-	mA
		Idle state on pin V_{BAT} ; Operating mode with load $R_L = 6\text{ }\Omega$ and no output signal (idle); DC-to-DC converter in Adaptive Boost mode; $V_{BAT} = 4.0\text{ V}$, $V_{DDP} = 8.5\text{ V}$	-	1.8	-	mA
		Power-down state on pin V_{BAT} ; DC-to-DC in power down mode; $T_j = 25\text{ }^\circ\text{C}$, no clock.	-	1	-	μA
V_{DDP}	power supply voltage	on pin V_{DDP}	2.7	-	10	V
$V_{DD(IO)}$	input/output supply voltage	on pin V_{DDE}	1.65	1.8	1.95	V
V_{DDD}	digital supply voltage	on pin V_{DDD}	1.65	1.8	1.95	V
I_{DDD}	digital supply current	Active state on pin V_{DDD} ; Operating mode with load $R_L = 6\text{ }\Omega$; DC-to-DC in Adaptive Boost mode; $P_o = 380\text{ mW}$, (average music power); $V_{BAT} = 4.0\text{ V}$; $V_{DDP} = 8.5\text{ V}$	-	6.8	-	mA
		Idle state on pin V_{DDD} ; Operating mode with load $R_L = 6\text{ }\Omega$ and no output signal (idle); DC-to-DC converter in Adaptive Boost mode; $V_{BAT} = 4.0\text{ V}$, $V_{DDP} = 8.5\text{ V}$	-	4.1	-	mA
		Power-down state on pin V_{DDD} ; DC-to-DC in power down mode; $T_j = 25\text{ }^\circ\text{C}$, no clock.	-	10	-	μA
Pins FS, BCK, DATAI, ADS1, ADS2, SCL, SDA, PDMCLK, PDMDAT, RST, TRSTN						
V_{IH}	HIGH-level input voltage		$0.7V_{DDD}$	-	3.6	V
V_{IL}	LOW-level input voltage		-	-	$0.3V_{DDD}$	V
C_i	input capacitance		[2]	-	3	pF

Symbol	Parameter	Conditions	Min	Typ	Max	Unit
I_{LI}	input leakage current	1.8 V on input pin	-	-	0.1	μ A
Pins DATA0, INT, PDMDAT, push-pull output stages						
V_{OH}	HIGH-level output voltage	$I_{OH} = 4$ mA	-	-	$V_{DDD} - 0.4$	V
V_{OL}	LOW-level output voltage	$I_{OL} = 4$ mA	-	-	400	mV
Pins SDA, open drain outputs, external 10 k Ω resistor to V_{DDD}						
V_{OH}	HIGH-level output voltage	$I_{OH} = 4$ mA	-	-	$V_{DDD} - 0.4$	V
V_{OL}	LOW-level output voltage	$I_{OL} = 4$ mA	-	-	400	mV
Pins OUTA, OUTB						
R_{DSon}	drain-source on-state resistance	PMOS + NMOS transistors	-	510	-	m Ω
Protection						
$T_{act(th_prot)}$	thermal protection activation temperature		130	-	150	$^{\circ}$ C
$V_{uvp(VBAT)}$	undervoltage protection voltage on pin VBAT		2.3	-	2.5	V
$I_{O(ocp)}$	overcurrent protection output current		2	-	-	A
DC-to-DC converter						
V_{bst}	boost voltage	DCVOS = 111; Boost mode (after trimming)	9.32	9.5	9.68	V

[1] L_{BST} = boost converter inductance; R_L = load resistance; L_L = load inductance (speaker).

[2] This parameter is not tested during production; the value is guaranteed by design and checked during product validation.

11.2 AC characteristics

Table 7. AC characteristics

All parameters guaranteed for $V_{BAT} = 3.6\text{ V}$; $V_{DDD} = 1.8\text{ V}$; $V_{DDP} = V_{BST} = 9.0\text{ V}$; Adaptive Boost mode; $L_{BST} = 1\ \mu\text{H}^{[1]}$; $R_L = 8\ \Omega^{[1]}$; $L_L = 44\ \mu\text{H}^{[1]}$; $f_i = 1\text{ kHz}$; $f_s = 48\text{ kHz}$; $T_{amb} = 25\text{ }^\circ\text{C}$; default settings, unless otherwise specified.

Symbol	Parameter	Conditions	Min	Typ	Max	Unit	
Amplifier output power							
$P_{O(AV)}$	average output power	Hands-free speaker, THD+N = 1 %					
		$R_L = 8\ \Omega$; $f_s = 48\text{ kHz}$, $V_{BST} = 9.5\text{ V}$, $V_{BAT} = 4.0\text{ V}$	3.6	5.1	-	W	
		$R_L = 6\ \Omega$; $f_s = 48\text{ kHz}$, $V_{BST} = 9.5\text{ V}$, $V_{BAT} = 4.0\text{ V}$	-	5.9	-	W	
		$R_L = 4\ \Omega$; $f_s = 48\text{ kHz}$, $V_{BST} = 9.5\text{ V}$, $V_{BAT} = 4.0\text{ V}$	-	6.0	-	W	
		$R_L = 8\ \Omega$; $f_s = 48\text{ kHz}$, $V_{BST} = 8.5\text{ V}$, $V_{BAT} = 3.6\text{ V}$	3.6	4.0	-	W	
		$R_L = 6\ \Omega$; $f_s = 48\text{ kHz}$, $V_{BST} = 8.5\text{ V}$, $V_{BAT} = 3.6\text{ V}$	-	5.1	-	W	
		$R_L = 4\ \Omega$; $f_s = 48\text{ kHz}$, $V_{BST} = 8.5\text{ V}$, $V_{BAT} = 3.6\text{ V}$	-	5.2	-	W	
		Receiver speaker. THD+N = 1 %; $V_{BST} = 9.5\text{ V}$,					
		$R_L = 32\ \Omega$; Voice mode	-	0.2	-	W	
$R_L = 32\ \Omega$; Audio mode	-	1.2	-	W			
Amplifier output pins (OUTA and OUTB)							
$ V_{O(\text{offset})} $	output offset voltage	absolute value after trimming; $V_{DDP} = 3.4\text{ V to }9.5\text{ V}$, $V_{BAT} = 3.4\text{ V to }5\text{ V}$	-	-	1.0	mV	
Amplifier performances							
η_{po}	output power efficiency	on pin VBAT; Operating mode with load; $R_L = 6\ \Omega$; DC-to-DC in Adaptive Boost mode, $P_o = 380\text{ mW}$, (average music power), $V_{BAT} = 4.0\text{ V}$, $V_{DDP} = 8.5\text{ V}$	[2]	-	80	-	%
		on pin VBAT; input: 100 Hz sine wave, $R_L = 8\ \Omega$; DC-to-DC in Adaptive Boost mode, $V_{BAT} = 4.0\text{ V}$, $V_{DDP} = 8.5\text{ V}$, $P_o = 700\text{ mW}$	[2]	-	90	-	%
		on pin VBAT; input: 100 Hz sine wave, $R_L = 8\ \Omega$; DC-to-DC in Adaptive Boost mode, $V_{BAT} = 4.0\text{ V}$, $V_{DDP} = 8.5\text{ V}$, $P_o = 4\text{ W}$	[2]	-	84	-	%
THD+N	total harmonic distortion-plus-noise	$V_{DDP} > 9\text{ V}$, $P_o = 2.0\text{ W}$, $R_L = 8\ \Omega$	[2]	-	0.04	0.09	%
		$V_{DDP} > 9\text{ V}$, $P_o = 2.0\text{ W}$, $R_L = 4\ \Omega$	[2]	-	-	0.09	%
$V_{n(o)}$	output noise voltage	A-weighted; DATA1 = 0 V; Low Noise mode (ISTLA = 1); $f_s = 8\text{ kHz}$	[2]	-	19	24	μV

High Efficiency Class-D Audio Amplifier with Speaker-as-Microphone

Symbol	Parameter	Conditions	Min	Typ	Max	Unit
		A-weighted; DATAI = 0 V; Low Noise mode (ISTLA = 1); $f_s = 16$ kHz	[2] -	55	60	μ V
S/N	signal-to-noise ratio	A-weighted, $V_{BAT} = 3.4$ V to 5 V, maximum signal at THD = 1 %	[2] 100	-	-	dB
PSRR	power supply rejection ratio	from V_{BAT} ; booster in follower mode ($V_{DDP} = V_{BAT}$); $f_{ripple} = 217$ Hz square wave, $V_{ripple} = 50$ mV(p-p), $V_{BAT} = 4.0$ V	-	80	-	dB
		from V_{BAT} ; booster in follower mode ($V_{DDP} = V_{BAT}$); $f_{ripple} = 20$ Hz to 1 kHz sine wave, $V_{ripple} = 200$ mV (RMS), $V_{BAT} = 3.4$ V to 5.0 V; Low Power and Low Noise modes on	60	80	-	dB
		from V_{BAT} ; $f_{ripple} = 20$ Hz to 1 kHz sine wave, $V_{ripple} = 200$ mV (RMS), $V_{BAT} = 3.4$ V to 5.0 V; DC-DC in follower OR booster; Low Power and Low Noise modes off	-	75	-	dB
		from V_{BAT} ; booster in follower mode ($V_{DDP} = V_{BAT}$); $f_{ripple} = 1$ kHz to 20 kHz sine wave, $V_{ripple} = 200$ mV (RMS), $V_{BAT} = 3.4$ V to 5.0 V	-	70	-	dB
$\Delta G/\Delta f$	gain variation with frequency	BW = 20 Hz to 15 kHz, $V_{BAT} = 3.4$ V to 5 V	-0.1	-	0.7	dB
V_{POP}	pop noise voltage	at mode transition and gain change.			2	mV
R_L	load resistance		4	8	32	Ω
C_L	load capacitance		-	-	200	pF
f_{sw}	switching frequency	directly coupled to the I ² S input frequency	256	-	384	kHz
G_v	voltage gain	I ² S/TDM to V_O ; INPLEV = 0 (0 dB)	6	-	21	dB

Amplifier power-up, power-down and propagation delays

$t_{d(on)PLL}$	PLL turn-on delay time	PLL locked on BCK, $f_s = 48$ kHz	-	2	-	ms
$t_{d(on)amp}$	amplifier turn-on delay time	$f_s = 48$ kHz	-	1	-	ms
$t_{d(off)}$	turn-off delay time		-	32	-	μ s
$t_{d(alarm)}$	alarm delay time		-	200	-	ms
t_{PD}	propagation delay	$f_s = 16$ kHz (I ² S/TDM)	-	1750	-	μ s
		$f_s = 48$ kHz (I ² S/TDM)	-	600	-	μ s
		$f_s = 96/192$ kHz (I ² S/TDM)	-	320	-	μ s
		$f_s = 48$ kHz (PDM)	-	70	-	μ s

Booster Inductance

L_{bst}	boost inductance		0.7	1.0	2.2	μ H
-----------	------------------	--	-----	-----	-----	---------

Current-sensing performance

$L_{L(spk)}$	speaker load inductance		30	-	-	μ H
--------------	-------------------------	--	----	---	---	---------

High Efficiency Class-D Audio Amplifier with Speaker-as-Microphone

Symbol	Parameter	Conditions	Min	Typ	Max	Unit
S/N	signal-to-noise ratio	$I_O = 1.1A$ (peak); A-weighted	62	65	-	dB
ΔI_{sense}	current sense mismatch	over frequency; 20 Hz to 4 kHz	-	-	3	%
		over temperature; $f_i = 1$ kHz; $T_j = -20$ °C to 85 °C	-	2	-	%
		over V_{DDP} ; $f_i = 1$ kHz, $V_{DDP} = 2.7$ V to 9.5 V	-	1	-	%
THD+N	total harmonic distortion-plus-noise	$f_i = 20$ Hz to 20 kHz; $V_i = -6$ dBFS; TDMSPKG = 0110	-	-	0.75	%
B	bandwidth		[2] 0.02	-	20	kHz
Speaker-as-microphone performance; pins OUTA, OUTB						
GPGA	PGA gain	PGAGAIN = 30 dB (± 1.5 dB accuracy)	-	27.6	-	dB
		PGAGAIN = 24 dB (± 1.5 dB accuracy)	-	22.2	-	dB
		PGAGAIN = 18 dB (± 1.5 dB accuracy)	-	16.8	-	dB
		PGAGAIN = 16 dB (± 1.5 dB accuracy)	-	14.9	-	dB
$V_{i(max)}$	maximum input voltage	PGAGAIN = 18 dB; RMS value	[3] -	10.5	-	mV
		PGAGAIN = 30 dB; RMS value	[4] -	3.0	-	mV
$V_{n(i)(eq)}$	equivalent input noise voltage	A-weighted, PGAGAIN: 30 dB; TDM Output; RMS value	-	1.05	-	μ V
		A-weighted, PGAGAIN: 16 dB; TDM Output; RMS value	-	2.35	-	μ V
		A-weighted, PGAGAIN: 30 dB; PDM Output; RMS value	-	1.20	-	μ V
		A-weighted, PGAGAIN: 16 dB; PDM Output; RMS value	-	1.35	-	μ V
S/N	signal-to-noise ratio	A-weighted; PDM output; full scale input; PGAGAIN: 18 dB;	-	78.6	-	dB
		A-weighted; PPDM Output Full scale input, PGA gain setting GAIN_00	-	70.3	-	dB
		A-weighted; PTDM output; full scale input; PGAGAIN: 18 dB;	-	76.9	-	dB
		TDM output; full scale input; PGAGAIN: 30 dB	-	69.6	-	dB
THD+N	total harmonic distortion-plus-noise	$f_i = 1$ kHz, $V_i = 0.5\Omega$ mV (RMS), maximum PGA gain setting (30 dB), on pin OUTA/OUTB	-	0.3	-	%
		$f_i = 1$ kHz, $V_i = 0.5$ mV (RMS), maximum PGA gain setting (30 dB), on pin AUXSAMN/AUXSAMP	-	0.45	-	%

Symbol	Parameter	Conditions	Min	Typ	Max	Unit
PSRR	power supply rejection ratio	square wave on VDDD, $f_{\text{ripple}} = 217$ Hz, $V_{\text{ripple}} = 50$ mV (p-p), maximum PGA gain setting (30 dB)	-	70	-	dB
		sine wave on VDDD, $f_{\text{ripple}} = 20$ Hz to 1 kHz, $V_{\text{ripple}} = 100$ mV (RMS), maximum PGA gain setting (30 dB)	-	70	-	dB
		sine wave on VDDD, $f_{\text{ripple}} = 1$ kHz to 20 kHz, $V_{\text{ripple}} = 100$ mV (RMS), maximum PGA gain setting (30 dB)	-	60	-	dB
$V_{O(\text{offset})}$	output offset voltage	% of Full Scale; PDM output only (offset is removed on TDM output)	^[5] -10	-	10	%

- [1] L_{BST} = boost converter inductance; R_L = load resistance; L_L = load inductance (speaker).
- [2] This parameter is not tested during production; the value is guaranteed by design and checked during product validation.
- [3] Overload level at input; output is specified at 0 dBFS for TDM/PDM output max, or output limited at THD+N = 1 % if reached before 0 dBFS; THD = 1 %.
- [4] Overload level at input; output is specified at 0 dBFS for TDM/PDM output max, or output limited at THD+N = 1 % if reached before 0 dBFS; THD = 1 %.
- [5] When using PDM output for Speaker-as-Microphone, PDM stream decimation shall be done in codec or AP running SAM software and it must include a DC offset remover.

11.3 I²S timing characteristics

Table 8. I²S bus interface characteristics; see Figure 4

All parameters are guaranteed for $V_{BAT} = 3.6\text{ V}$; $V_{DDD} = 1.8\text{ V}$; $V_{DDP} = V_{BST} = 9.0\text{ V}$, Adaptive Boost mode; $L_{BST} = 1\ \mu\text{H}^{[1]}$; $R_L = 8\ \Omega^{[1]}$; $L_L = 44\ \mu\text{H}^{[1]}$; $f_i = 1\text{ kHz}$; $f_s = 48\text{ kHz}$; $T_{amb} = 25\text{ }^\circ\text{C}$; default settings, unless otherwise specified.

Symbol	Parameter	Conditions	Min	Typ	Max	Unit
f_s	sampling frequency	on pin WS, audio mode	[2] 16	-	48	kHz
		on pin WS, ultrasonic mode	96	-	192	kHz
f_{clk}	clock frequency	on pin BCK, audio mode	[2] $32f_s$	-	$384f_s$	kHz
		on pin BCK, ultrasonic mode	-	-	$96f_s$	MHz
t_{su}	set-up time	WS edge to BCK HIGH	[3] 10	-	-	ns
		DATA edge to BCK HIGH	10	-	-	ns
t_h	hold time	BCK HIGH to WS edge	[3] 10	-	-	ns
		BCK HIGH to DATA edge	10	-	-	ns

[1] L_{BST} = boost converter inductance; R_L = load resistance; L_L = load inductance.

[2] The I²S bit clock input (BCK) is used as a clock input for the amplifier and the DC-to-DC converter. Note that both the BCK and WS signals must be present for the clock to operate correctly.

[3] This parameter is not tested during production; the value is guaranteed by design and checked during product validation.

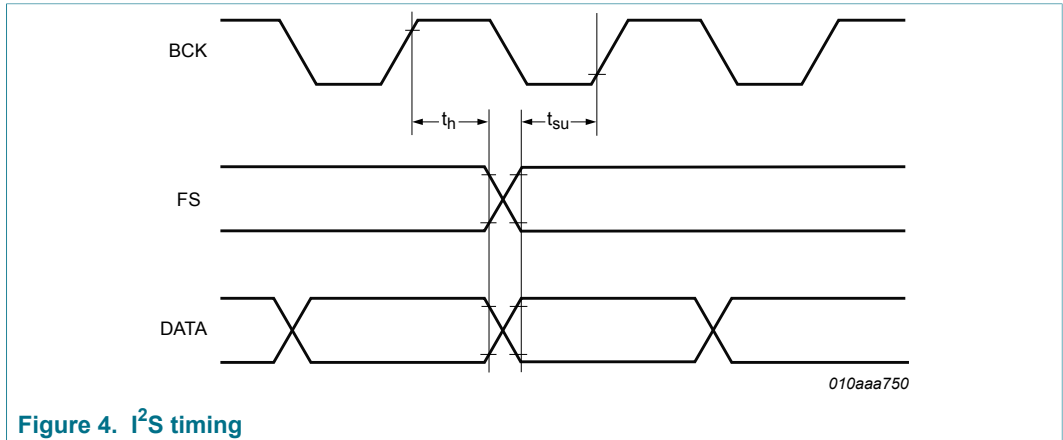

Figure 4. I²S timing

11.4 I²C timing characteristics

Table 9. I²C-bus interface characteristics; see Figure 5

All parameters are guaranteed for $V_{BAT} = 3.6\text{ V}$; $V_{DDD} = 1.8\text{ V}$; $V_{DDP} = V_{BST} = 9.0\text{ V}$, Adaptive Boost mode; $L_{BST} = 1\text{ }\mu\text{H}^{[1]}$; $R_L = 8\text{ }\Omega^{[1]}$; $L_L = 44\text{ }\mu\text{H}^{[1]}$; $f_i = 1\text{ kHz}$; $f_s = 48\text{ kHz}$; $T_{amb} = 25\text{ }^\circ\text{C}$; default settings, unless otherwise specified.

Symbol	Parameter	Conditions	Min	Typ	Max	Unit
f_{SCL}	SCL clock frequency		-	-	400	kHz
t_{LOW}	LOW period of the SCL clock		1.3	-	-	μs
t_{HIGH}	HIGH period of the SCL clock		0.6	-	-	μs
t_r	rise time	SDA and SCL signals	$20 + 0.1 C_b$	-	-	ns
t_f	fall time	SDA and SCL signals	$20 + 0.1 C_b$	-	-	ns
$t_{HD;STA}$	hold time (repeated) START condition		0.6	-	-	μs
$t_{SU;STA}$	set-up time for a repeated START condition		0.6	-	-	μs
$t_{SU;STO}$	set-up time for STOP condition		0.6	-	-	μs
t_{BUF}	bus free time between a STOP and START condition		1.3	-	-	μs
$t_{SU;DAT}$	data set-up time		100	-	-	ns
$t_{HD;DAT}$	data hold time		0	-	-	μs
t_{SP}	pulse width of spikes that must be suppressed by the input filter		0	-	50	ns
C_b	capacitive load for each bus line		-	-	400	pF

- [1] L_{BST} = boost converter inductance; R_L = load resistance; L_L = load inductance.
- [2] C_b is the total capacitance of one bus line in pF. The maximum capacitive load for each bus line is 400 pF.
- [3] After this period, the first clock pulse is generated.
- [4] To be suppressed by the input filter.

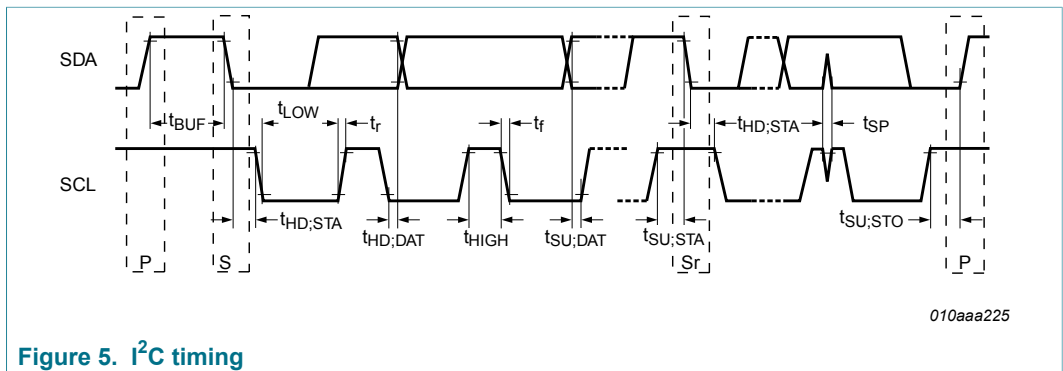

Figure 5. I²C timing

11.5 PDM timing characteristics

Table 10. PDM interface characteristics; see Figure 6

All parameters are guaranteed for $V_{BAT} = 3.6\text{ V}$; $V_{DDD} = 1.8\text{ V}$; $V_{DDP} = V_{BST} = 9.0\text{ V}$, Adaptive Boost mode; $L_{BST} = 1\text{ }\mu\text{H}^{[1]}$; $R_L = 8\text{ }\Omega^{[1]}$; $L_L = 44\text{ }\mu\text{H}^{[1]}$; $f_i = 1\text{ kHz}$; $f_s = 48\text{ kHz}$; $T_{amb} = 25\text{ }^\circ\text{C}$; default settings, unless otherwise specified.

Symbol	Parameter	Conditions	Min	Typ	Max	Unit
f_{clk}	clock frequency		-	3.072 ^[2]	-	MHz
\bar{D}_{clk}	clock duty cycle		45	-	55	%
t_h	hold time	after clock HIGH	30	-	-	ns
		after clock LOW	30	-	-	ns
t_{su}	set-up time	after clock HIGH	30	-	-	ns
		after clock LOW	30	-	-	ns

[1] L_{BST} = boost converter inductance; R_L = load resistance; L_L = load inductance.
 [2] PDM Clock is 64xfs, with fs selected by AUDFS. Typical 3.072 Mhz is corresponding to $f_s = 48\text{ kHz}$.

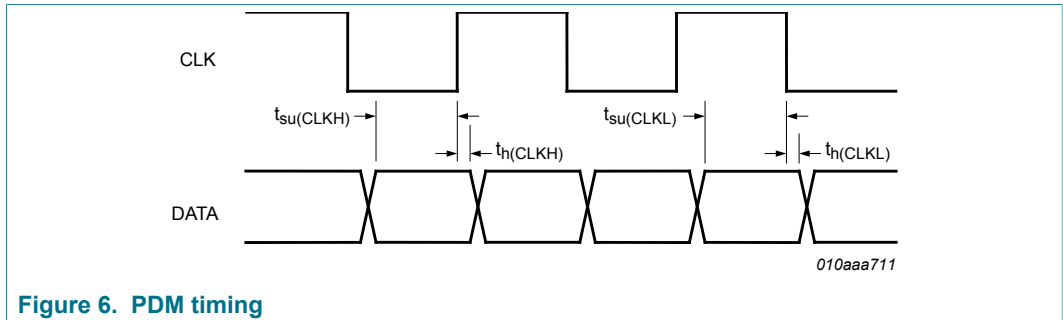

Figure 6. PDM timing

12 Application information

12.1 Application diagrams

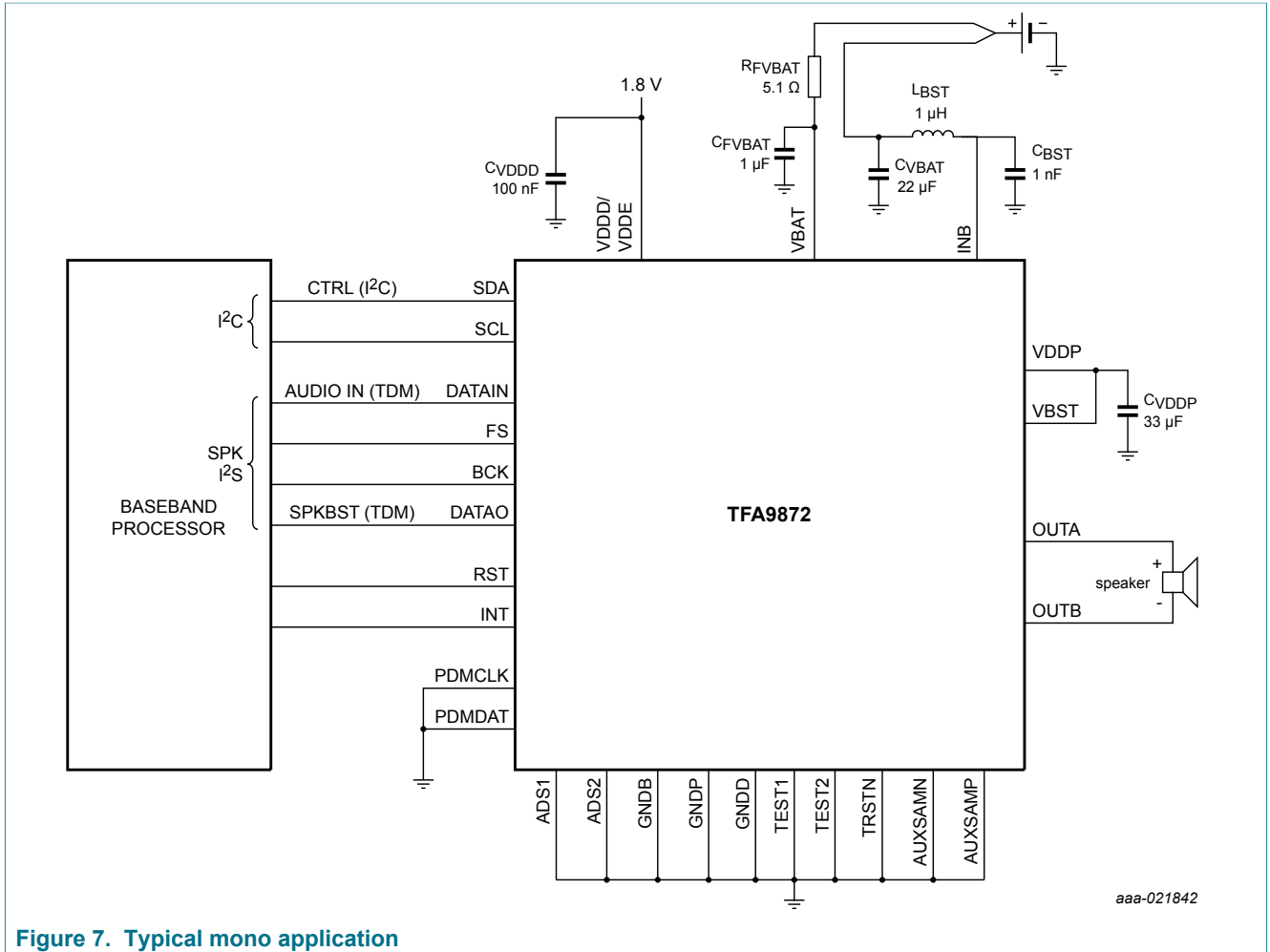

Figure 7. Typical mono application

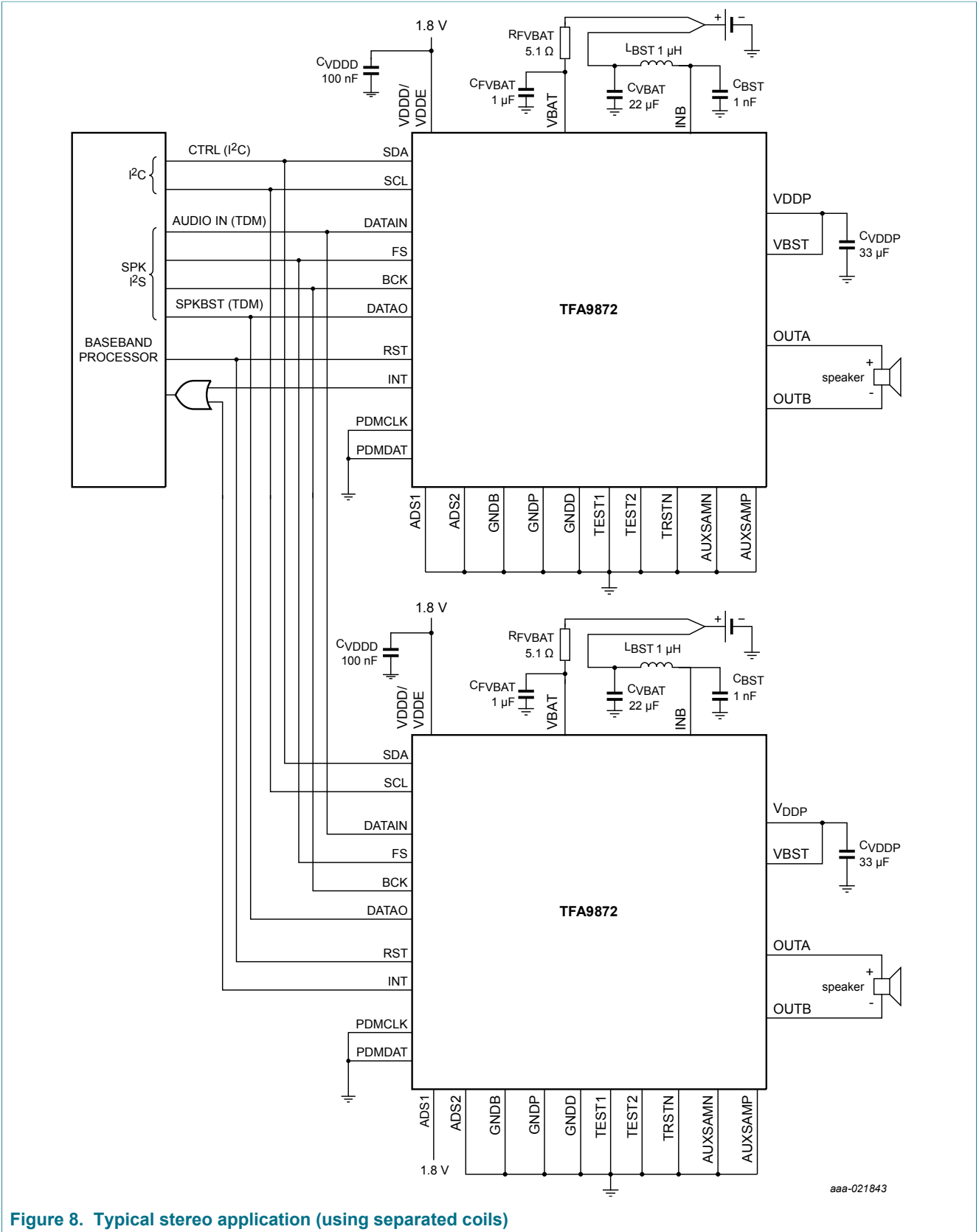

Figure 8. Typical stereo application (using separated coils)

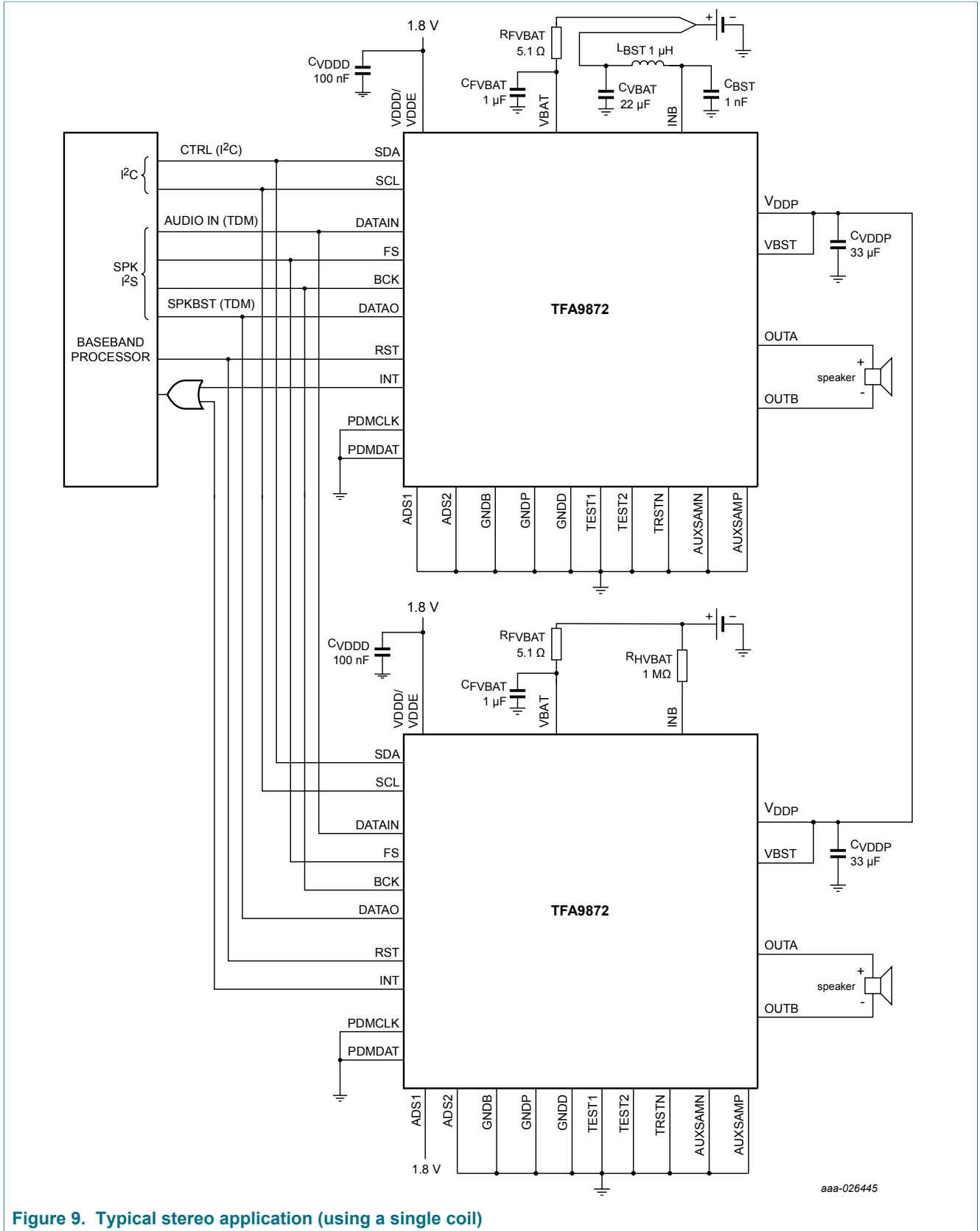
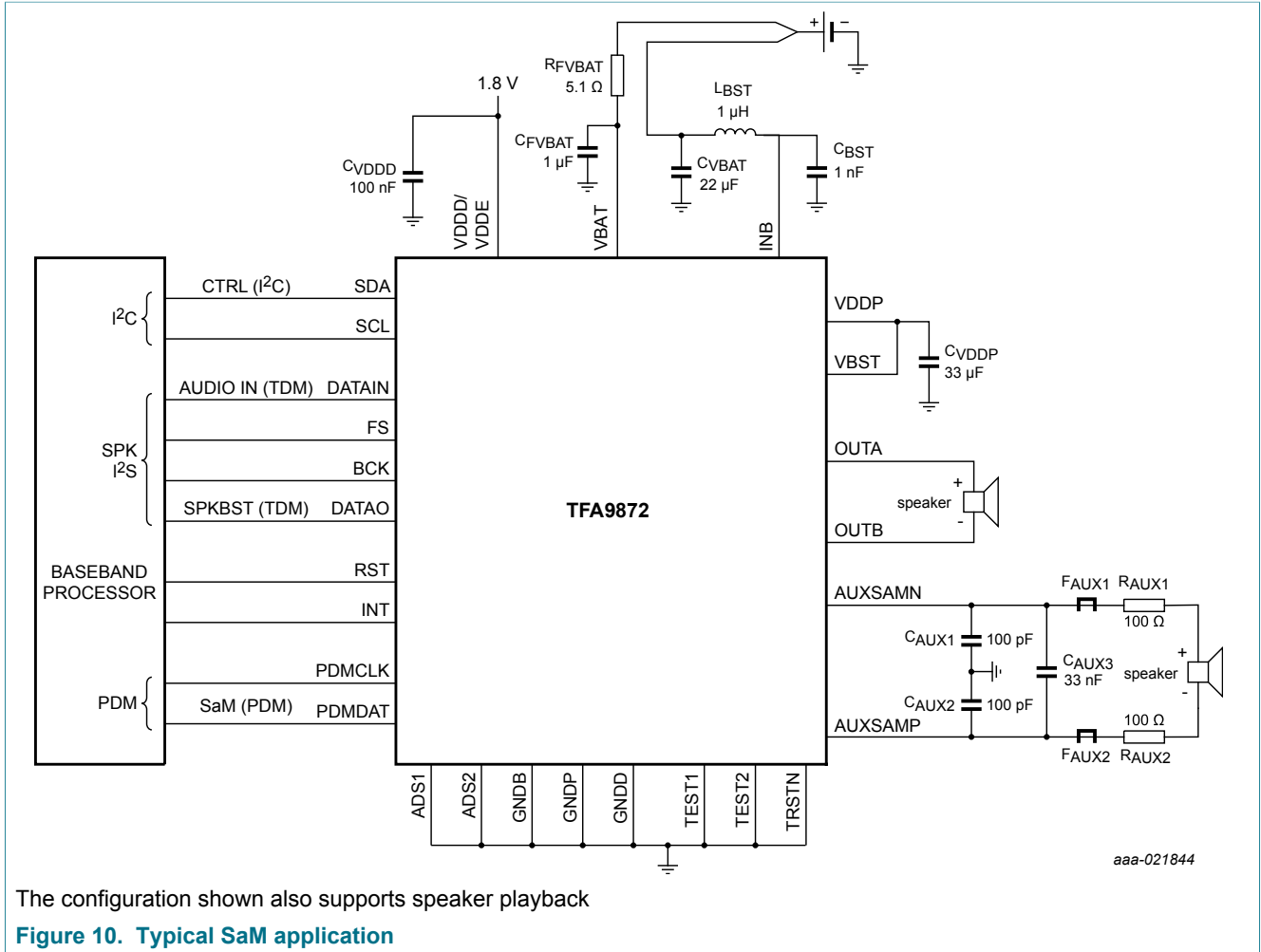

Figure 9. Typical stereo application (using a single coil)



13 Package outline

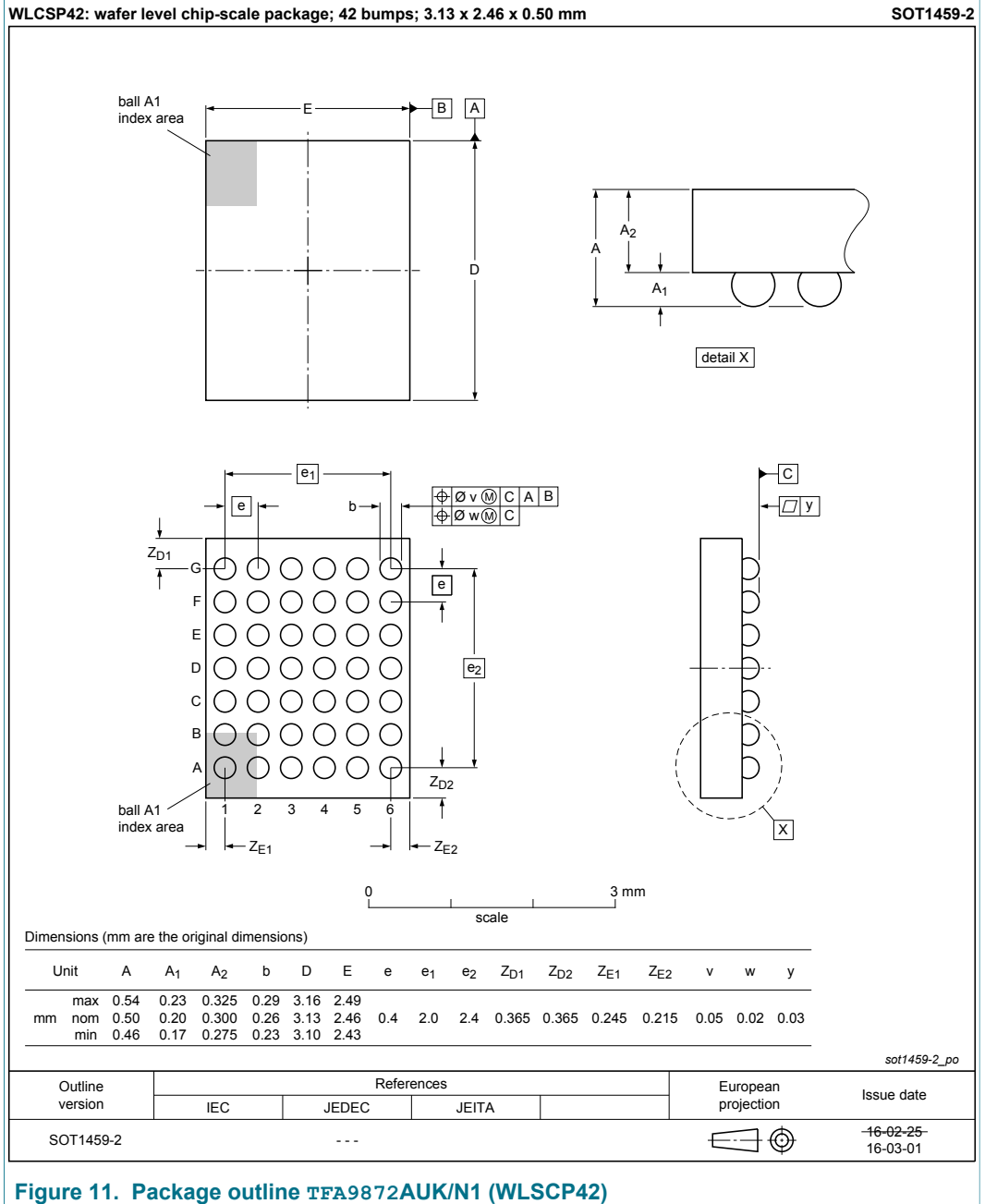

Figure 11. Package outline TFA9872AUK/N1 (WLSCP42)

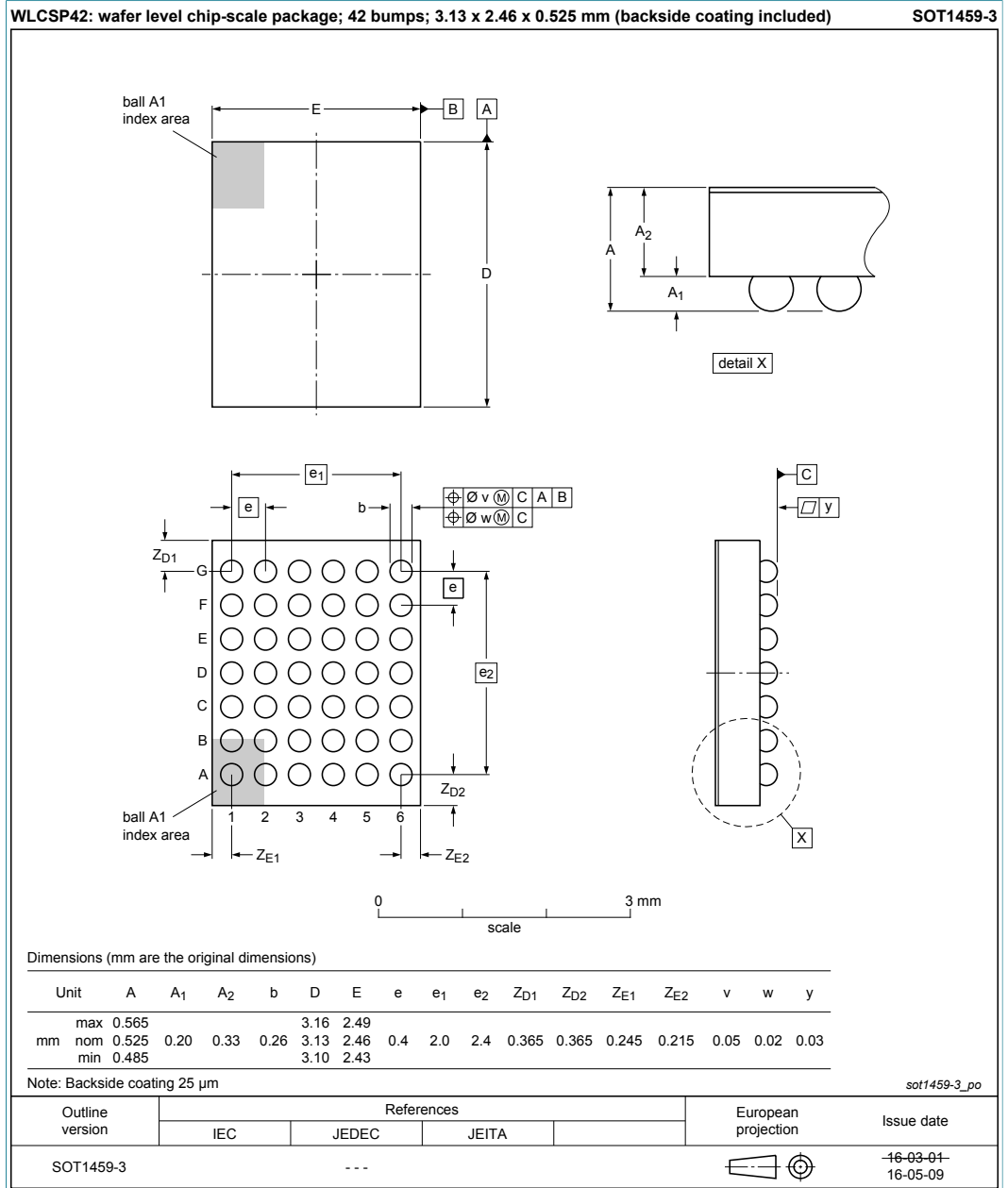

Figure 12. Package outline TFA9872CUK/N1 (WLCSP42)

14 Soldering of WLCSP packages

14.1 Introduction to soldering WLCSP packages

This text provides a very brief insight into a complex technology. A more in-depth account of soldering WLCSP (Wafer Level Chip-Size Packages) can be found in application note AN10439 “Wafer Level Chip Scale Package” and in application note AN10365 “Surface mount reflow soldering description”.

Wave soldering is not suitable for this package.

All NXP WLCSP packages are lead-free.

14.2 Board mounting

Board mounting of a WLCSP requires several steps:

1. Solder paste printing on the PCB
2. Component placement with a pick and place machine
3. The reflow soldering itself

14.3 Reflow soldering

Key characteristics in reflow soldering are:

- Lead-free versus SnPb soldering; note that a lead-free reflow process usually leads to higher minimum peak temperatures (see Figure 1) than a SnPb process, thus reducing the process window
- Solder paste printing issues, such as smearing, release, and adjusting the process window for a mix of large and small components on one board
- Reflow temperature profile; this profile includes preheat, reflow (in which the board is heated to the peak temperature), and cooling down. It is imperative that the peak temperature is high enough for the solder to make reliable solder joints (a solder paste characteristic) while being low enough that the packages and/or boards are not damaged. The peak temperature of the package depends on package thickness and volume and is classified in accordance with [Table 11](#).

Table 11. Lead-free process (from J-STD-020D)

Package thickness (mm)	Package reflow temperature (°C)		
	Volume (mm ³)		
	< 350	350 to 2000	> 2000
< 1.6	260	260	260
1.6 to 1.5	260	250	245
> 2.5	250	245	245

Moisture sensitivity precautions, as indicated on the packing, must be respected at all times.

Studies have shown that small packages reach higher temperatures during reflow soldering, see [Figure 13](#).

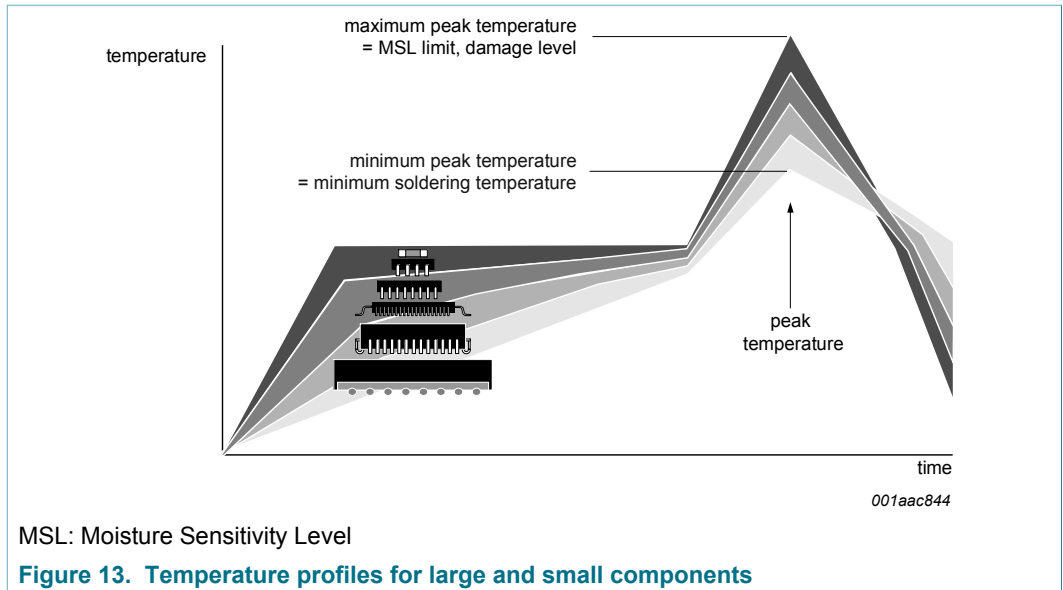

For further information on temperature profiles, refer to application note AN10365 “Surface mount reflow soldering description”.

14.3.1 Stand off

The stand off between the substrate and the chip is determined by:

- The amount of printed solder on the substrate
- The size of the solder land on the substrate
- The bump height on the chip

The higher the stand off, the better the stresses are released due to TEC (Thermal Expansion Coefficient) differences between substrate and chip.

The higher the stand off, the better the stresses are released due to TEC (Thermal Expansion Coefficient) differences between substrate and chip.

14.3.2 Quality of solder joint

A flip-chip joint is considered to be a good joint when the entire solder land has been wetted by the solder from the bump. The surface of the joint should be smooth and the shape symmetrical. The soldered joints on a chip should be uniform. Voids in the bumps after reflow can occur during the reflow process in bumps with high ratio of bump diameter to bump height, i.e. low bumps with large diameter. No failures have been found to be related to these voids. Solder joint inspection after reflow can be done with X-ray to monitor defects such as bridging, open circuits and voids.

14.3.3 Rework

In general, rework is not recommended. By rework we mean the process of removing the chip from the substrate and replacing it with a new chip. If a chip is removed from the substrate, most solder balls of the chip will be damaged. In that case it is recommended not to re-use the chip again.

Device removal can be done when the substrate is heated until it is certain that all solder joints are molten. The chip can then be carefully removed from the substrate without damaging the tracks and solder lands on the substrate. Removing the device must be done using plastic tweezers, because metal tweezers can damage the silicon. The surface of the substrate should be carefully cleaned and all solder and flux residues and/or underfill removed. When a new chip is placed on the substrate, use the flux process instead of solder on the solder lands. Apply flux on the bumps at the chip side as well as on the solder pads on the substrate. Place and align the new chip while viewing with a microscope. To reflow the solder, use the solder profile shown in application note AN10365 "Surface mount reflow soldering description".

14.3.4 Cleaning

Cleaning can be done after reflow soldering.

15 Revision history

Table 12. Revision history

Document ID	Release date	Data sheet status	Change notice	Supersedes
TFA9872_SDS v.1	20170412	Product data sheet	-	-

16 Legal information

16.1 Data sheet status

Document status ^{[1][2]}	Product status ^[3]	Definition
Objective [short] data sheet	Development	This document contains data from the objective specification for product development.
Preliminary [short] data sheet	Qualification	This document contains data from the preliminary specification.
Product [short] data sheet	Production	This document contains the product specification.

[1] Please consult the most recently issued document before initiating or completing a design.

[2] The term 'short data sheet' is explained in section "Definitions".

[3] The product status of device(s) described in this document may have changed since this document was published and may differ in case of multiple devices. The latest product status information is available on the Internet at URL <http://www.nxp.com>.

16.2 Definitions

Draft — The document is a draft version only. The content is still under internal review and subject to formal approval, which may result in modifications or additions. NXP Semiconductors does not give any representations or warranties as to the accuracy or completeness of information included herein and shall have no liability for the consequences of use of such information.

Short data sheet — A short data sheet is an extract from a full data sheet with the same product type number(s) and title. A short data sheet is intended for quick reference only and should not be relied upon to contain detailed and full information. For detailed and full information see the relevant full data sheet, which is available on request via the local NXP Semiconductors sales office. In case of any inconsistency or conflict with the short data sheet, the full data sheet shall prevail.

Product specification — The information and data provided in a Product data sheet shall define the specification of the product as agreed between NXP Semiconductors and its customer, unless NXP Semiconductors and customer have explicitly agreed otherwise in writing. In no event however, shall an agreement be valid in which the NXP Semiconductors product is deemed to offer functions and qualities beyond those described in the Product data sheet.

16.3 Disclaimers

Limited warranty and liability — Information in this document is believed to be accurate and reliable. However, NXP Semiconductors does not give any representations or warranties, expressed or implied, as to the accuracy or completeness of such information and shall have no liability for the consequences of use of such information. NXP Semiconductors takes no responsibility for the content in this document if provided by an information source outside of NXP Semiconductors. In no event shall NXP Semiconductors be liable for any indirect, incidental, punitive, special or consequential damages (including - without limitation - lost profits, lost savings, business interruption, costs related to the removal or replacement of any products or rework charges) whether or not such damages are based on tort (including negligence), warranty, breach of contract or any other legal theory. Notwithstanding any damages that customer might incur for any reason whatsoever, NXP Semiconductors' aggregate and cumulative liability towards customer for the products described herein shall be limited in accordance with the Terms and conditions of commercial sale of NXP Semiconductors.

Right to make changes — NXP Semiconductors reserves the right to make changes to information published in this document, including without limitation specifications and product descriptions, at any time and without notice. This document supersedes and replaces all information supplied prior to the publication hereof.

Suitability for use — NXP Semiconductors products are not designed, authorized or warranted to be suitable for use in life support, life-critical or safety-critical systems or equipment, nor in applications where failure or malfunction of an NXP Semiconductors product can reasonably be expected to result in personal injury, death or severe property or environmental damage. NXP Semiconductors and its suppliers accept no liability for inclusion and/or use of NXP Semiconductors products in such equipment or applications and therefore such inclusion and/or use is at the customer's own risk.

Applications — Applications that are described herein for any of these products are for illustrative purposes only. NXP Semiconductors makes no representation or warranty that such applications will be suitable for the specified use without further testing or modification. Customers are responsible for the design and operation of their applications and products using NXP Semiconductors products, and NXP Semiconductors accepts no liability for any assistance with applications or customer product design. It is customer's sole responsibility to determine whether the NXP Semiconductors product is suitable and fit for the customer's applications and products planned, as well as for the planned application and use of customer's third party customer(s). Customers should provide appropriate design and operating safeguards to minimize the risks associated with their applications and products. NXP Semiconductors does not accept any liability related to any default, damage, costs or problem which is based on any weakness or default in the customer's applications or products, or the application or use by customer's third party customer(s). Customer is responsible for doing all necessary testing for the customer's applications and products using NXP Semiconductors products in order to avoid a default of the applications and the products or of the application or use by customer's third party customer(s). NXP does not accept any liability in this respect.

Limiting values — Stress above one or more limiting values (as defined in the Absolute Maximum Ratings System of IEC 60134) will cause permanent damage to the device. Limiting values are stress ratings only and (proper) operation of the device at these or any other conditions above those given in the Recommended operating conditions section (if present) or the Characteristics sections of this document is not warranted. Constant or repeated exposure to limiting values will permanently and irreversibly affect the quality and reliability of the device.

Terms and conditions of commercial sale — NXP Semiconductors products are sold subject to the general terms and conditions of commercial sale, as published at <http://www.nxp.com/profile/terms>, unless otherwise agreed in a valid written individual agreement. In case an individual agreement is concluded only the terms and conditions of the respective agreement shall apply. NXP Semiconductors hereby expressly objects to applying the customer's general terms and conditions with regard to the purchase of NXP Semiconductors products by customer.

No offer to sell or license — Nothing in this document may be interpreted or construed as an offer to sell products that is open for acceptance or the grant, conveyance or implication of any license under any copyrights, patents or other industrial or intellectual property rights.

Quick reference data — The Quick reference data is an extract of the product data given in the Limiting values and Characteristics sections of this document, and as such is not complete, exhaustive or legally binding.

Export control — This document as well as the item(s) described herein may be subject to export control regulations. Export might require a prior authorization from competent authorities.

Non-automotive qualified products — Unless this data sheet expressly states that this specific NXP Semiconductors product is automotive qualified, the product is not suitable for automotive use. It is neither qualified nor tested in accordance with automotive testing or application requirements. NXP Semiconductors accepts no liability for inclusion and/or use of non-automotive qualified products in automotive equipment or applications. In the event that customer uses the product for design-in and use in automotive applications to automotive specifications and standards, customer (a) shall use the product without NXP Semiconductors' warranty of the product for

such automotive applications, use and specifications, and (b) whenever customer uses the product for automotive applications beyond NXP Semiconductors' specifications such use shall be solely at customer's own risk, and (c) customer fully indemnifies NXP Semiconductors for any liability, damages or failed product claims resulting from customer design and use of the product for automotive applications beyond NXP Semiconductors' standard warranty and NXP Semiconductors' product specifications.

Translations — A non-English (translated) version of a document is for reference only. The English version shall prevail in case of any discrepancy between the translated and English versions.

16.4 Trademarks

Notice: All referenced brands, product names, service names and trademarks are the property of their respective owners.

Contents

1 General description 1

2 Features and benefits2

3 Applications2

4 Quick reference data 3

5 Ordering information 4

6 Block diagram 5

7 Pinning information 6

7.1 Pinning6

7.2 Pin description 7

8 Functional description9

9 Limiting values10

10 Thermal characteristics10

11 Characteristics 11

11.1 DC Characteristics 11

11.2 AC characteristics 13

11.3 I2S timing characteristics 17

11.4 I2C timing characteristics 18

11.5 PDM timing characteristics 19

12 Application information20

12.1 Application diagrams 20

13 Package outline24

14 Soldering of WLCSP packages26

14.1 Introduction to soldering WLCSP packages26

14.2 Board mounting 26

14.3 Reflow soldering 26

14.3.1 Stand off 27

14.3.2 Quality of solder joint 27

14.3.3 Rework 27

14.3.4 Cleaning 28

15 Revision history 29

16 Legal information 30

Please be aware that important notices concerning this document and the product(s) described herein, have been included in section 'Legal information'.

© NXP B.V. 2017.

All rights reserved.

For more information, please visit: <http://www.nxp.com>

For sales office addresses, please send an email to: salesaddresses@nxp.com

Date of release: 12 April 2017
 Document identifier: TFA9872_SDS

Looking for pricing, stock, or lifecycle information?

Click below to explore more details on WIN SOURCE:

- ⊖ [View TFA9872AUK/N1Z on WIN SOURCE](#)
- ⊖ [NXP / Nexperia Information](#)

Optimize Your Supply Chain with WIN SOURCE Solutions

- ✓ Global Sourcing Solution
- ✓ Obsolete Management
- ✓ Cost Control Management
- ✓ Shortage Management
- ✓ Alternative Solution
- ✓ Excess Inventory Management