



**THE DATASHEET OF
SI4133GX2-BM**





SILICON LABORATORIES

Si4133G-X2

DUAL-BAND RF SYNTHESIZER WITH INTEGRATED VCOS FOR GSM AND GPRS WIRELESS COMMUNICATIONS

Features

- Dual-band RF synthesizers
 - RF1: 900 MHz to 1.8 GHz
 - RF2: 750 MHz to 1.5 GHz
- IF synthesizer
 - 1070.4, 1080, and 1089.6 MHz
- Integrated VCOS, loop filters, varactors, and resonators
- Minimal number of external components required
- Optimized for use with Hitachi Bright2+ transceiver
- Settling time < 150 μ s
- Low phase noise
- Programmable powerdown modes
- 1 μ A standby current
- 18 mA typical supply current
- 2.7 to 3.6 V operation
- Packages: 24-pin TSSOP and 28-pin MLP

Applications

- GSM 850, E-GSM 900, DCS 1800, and PCS 1900 cellular telephones
- GPRS data terminals
- HSCSD data terminals

Description

The Si4133G-X2 is a monolithic integrated circuit that performs both IF and dual-band RF synthesis for GSM and GPRS wireless communications applications. The Si4133G-X2 includes three VCOS, loop filters, reference and VCO dividers, and phase detectors. Divider and powerdown settings are programmable through a three-wire serial interface.

Functional Block Diagram

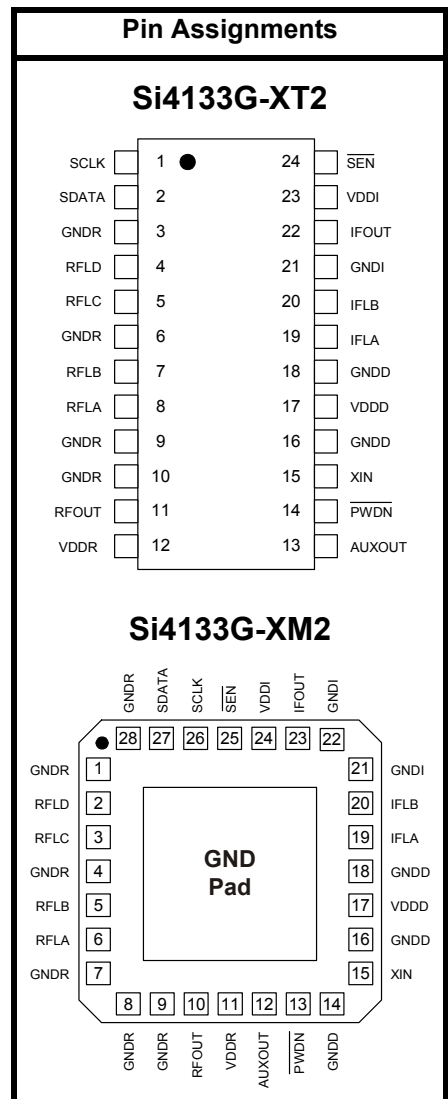
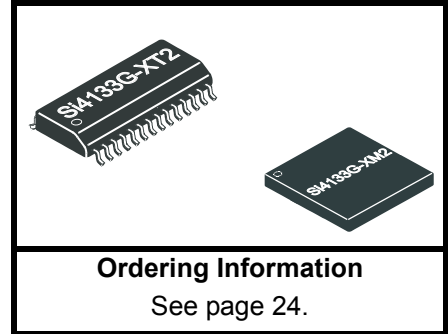
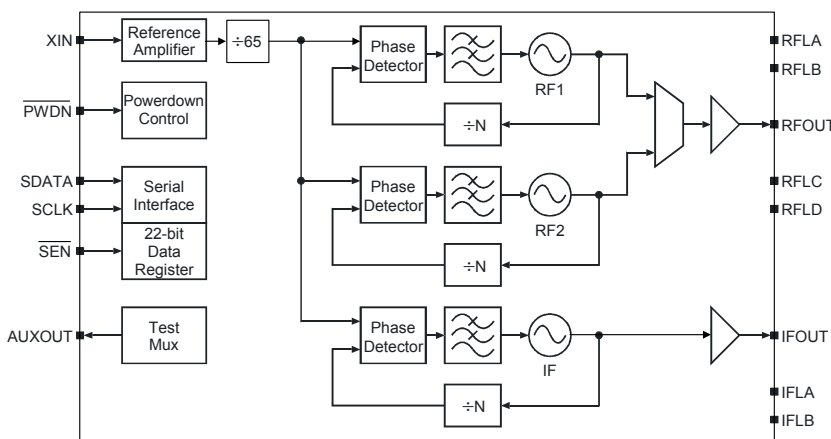

Patents pending

TABLE OF CONTENTS

<u>Section</u>	<u>Page</u>
Electrical Specifications	4
Typical Application Circuits	14
Functional Description	15
Serial Interface	15
Setting the VCO Center Frequencies	15
Self-Tuning Algorithm	16
Output Frequencies	17
PLL Loop Dynamics	17
RF and IF Outputs	17
Reference Frequency Amplifier	18
Powerdown Modes	18
Auxiliary Output (AUXOUT)	18
Control Registers	19
Pin Descriptions: Si4133G-XT2	22
Pin Descriptions: Si4133G-XM2	23
Ordering Guide	24
Package Outline: Si4133G-XT2	25
Package Outline: Si4133G-XM2	26
Document Change List	27
Contact Information	28



Si4133G-X2

Electrical Specifications

Table 1. Recommended Operating Conditions

Parameter	Symbol	Test Condition	Min	Typ	Max	Unit
Ambient Temperature	T_A		-20	25	85	°C
Supply Voltage	V_{DD}		2.7	3.0	3.6	V
Supply Voltages Difference	V_{Δ}	$(V_{DDR} - V_{DDD}),$ $(V_{DDI} - V_{DDD})$	-0.3	—	0.3	V

Note: All minimum and maximum specifications are guaranteed and apply across the recommended operating conditions. Typical values apply at 3.0 V and an operating temperature of 25 °C unless otherwise stated.

Table 2. Absolute Maximum Ratings^{1,2}

Parameter	Symbol	Value	Unit
DC Supply Voltage	V_{DD}	-0.5 to 4.0	V
Input Current ³	I_{IN}	±10	mA
Input Voltage ³	V_{IN}	-0.3 to $V_{DD}+0.3$	V
Storage Temperature Range	T_{STG}	-55 to 150	°C

Notes:

1. Permanent device damage may occur if the above Absolute Maximum Ratings are exceeded. Functional operation should be restricted to the conditions as specified in the operational sections of this data sheet. Exposure to absolute maximum rating conditions for extended periods may affect device reliability.
2. **This device is a high performance RF integrated circuit with an ESD rating of < 2 kV. Handling and assembly of this device should be done only at ESD-protected workstations.**
3. For signals SCLK, SDATA, \overline{SEN} , PWDN, and XIN.

Table 3. DC Characteristics(V_{DD} = 2.7 to 3.6 V, T_A = -20 to 85 °C)

Parameter	Symbol	Test Condition	Min	Typ	Max	Unit
Total Supply Current ¹		RF1 and IF operating	—	18	31	mA
RF1 Mode Supply Current ¹			—	13	17	mA
RF2 Mode Supply Current ¹			—	12	17	mA
IF Mode Supply Current ¹			—	10	14	mA
Standby Current		$\overline{\text{PWDN}}$	—	1	—	μA
High Level Input Voltage ²	V _{IH}		0.7 V _{DD}	—	—	V
Low Level Input Voltage ²	V _{IL}		—	—	0.3 V _{DD}	V
High Level Input Current ²	I _{IH}	V _{IH} = 3.6 V, V _{DD} = 3.6 V	-10	—	10	μA
Low Level Input Current ²	I _{IL}	V _{IL} = 0 V, V _{DD} = 3.6 V	-10	—	10	μA
High Level Output Voltage ³	V _{OH}	I _{OH} = -500 μA	V _{DD} -0.4	—	—	V
Low Level Output Voltage ³	V _{OL}	I _{OH} = 500 μA	—	—	0.4	V
Notes:						
1. RF1 = 1.55 GHz, RF2 = 1.2 GHz, IF = 1080 MHz						
2. For signals SCLK, SDATA, $\overline{\text{SEN}}$, and $\overline{\text{PWDN}}$.						
3. For signal AUXOUT.						

Si4133G-X2

Table 4. Serial Interface Timing

($V_{DD} = 2.7$ to 3.6 V, $T_A = -20$ to 85 °C)

Parameter ¹	Symbol	Test Condition	Min	Typ	Max	Unit
SCLK Cycle Time	t_{clk}	Figure 1	40	—	—	ns
SCLK Rise Time	t_r	Figure 1	—	—	50	ns
SCLK Fall Time	t_f	Figure 1	—	—	50	ns
SCLK High Time	t_h	Figure 1	10	—	—	ns
SCLK Low Time	t_l	Figure 1	10	—	—	ns
SDATA Setup Time to SCLK \uparrow ²	t_{su}	Figure 2	5	—	—	ns
SDATA Hold Time from SCLK \uparrow ²	t_{hold}	Figure 2	0	—	—	ns
$\overline{SEN}\downarrow$ to SCLK \uparrow Delay Time ²	t_{en1}	Figure 2	10	—	—	ns
SCLK \uparrow to $\overline{SEN}\uparrow$ Delay Time ²	t_{en2}	Figure 2	12	—	—	ns
$\overline{SEN}\uparrow$ to SCLK \uparrow Delay Time ²	t_{en3}	Figure 2	12	—	—	ns
\overline{SEN} Pulse Width	t_w	Figure 2	10	—	—	ns

Notes:

1. All timing is referenced to the 50% level of the waveform, unless otherwise noted.
2. Timing is not referenced to 50% level of waveform. See Figure 2.

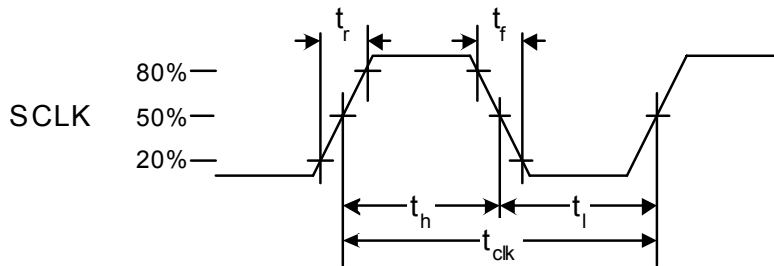

Figure 1. SCLK Timing Diagram

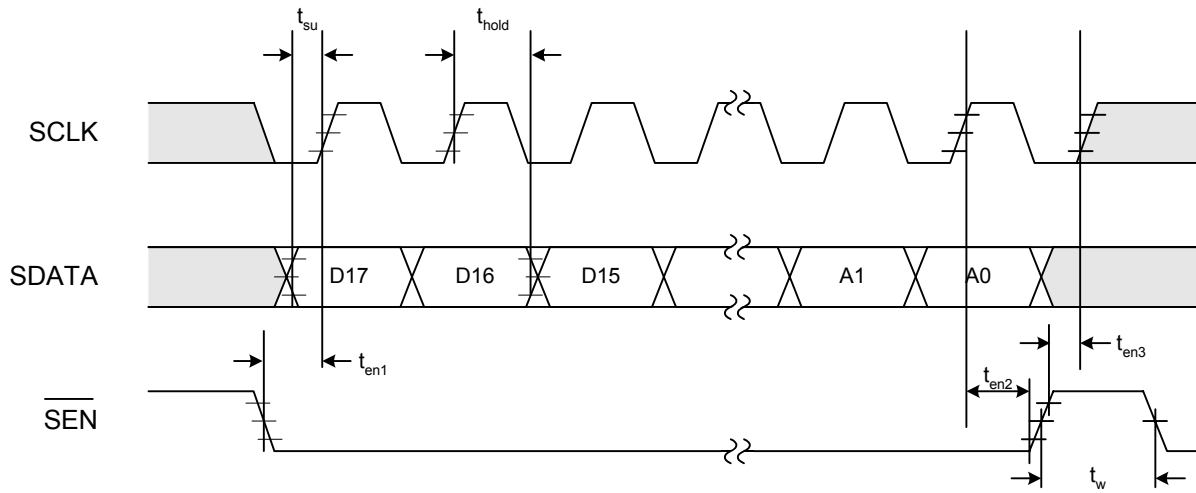

Figure 2. Serial Interface Timing Diagram

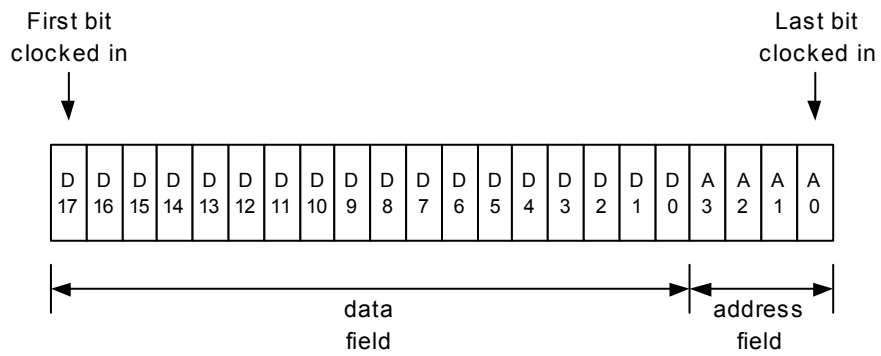

Figure 3. Serial Word Format

Si4133G-X2

Table 5. RF and IF Synthesizer Characteristics

($V_{DD} = 2.7$ to 3.6 V, $T_A = -20$ to 85 °C)

Parameter ¹	Symbol	Test Condition	Min	Typ	Max	Unit
XIN Input Frequency	f_{REF}		—	13	—	MHz
Reference Amplifier Sensitivity	V_{REF}		0.5	—	$V_{DD} + 0.3$	V_{PP}
Internal Phase Detector Frequency	f_{ϕ}	$f_{\phi} = f_{REF}/65$		200		KHz
RF1 VCO Center Frequency Range	f_{CEN}		947	—	1720	MHz
RF2 VCO Center Frequency Range	f_{CEN}		789	—	1429	MHz
IFOUT Center Frequency	f_{CEN}		—	1080	—	MHz
Tuning Range from f_{CEN}		Note: $L_{EXT} \pm 10\%$	-5	—	5	%
RF1 VCO Pushing		Open loop	—	0.5	—	MHz/V
RF2 VCO Pushing			—	0.4	—	MHz/V
IF VCO Pushing			—	0.3	—	MHz/V
RF1 VCO Pulling		VSWR = 2:1, all phases, open loop	—	0.4	—	MHz _{PP}
RF2 VCO Pulling			—	0.1	—	MHz _{PP}
IF VCO Pulling			—	0.1	—	MHz _{PP}
RF1 Phase Noise		1 MHz offset	—	-132	—	dBc/Hz
		3 MHz offset	—	-142	—	dBc/Hz
RF2 Phase Noise		1 MHz offset	—	-134	—	dBc/Hz
		3 MHz offset	—	-144	—	dBc/Hz
IF Phase Noise		100 kHz offset	—	-117	—	dBc/Hz
RF1 Integrated Phase Error		100 Hz to 100 kHz	—	0.9	—	deg rms
RF1 Harmonic Suppression		Second Harmonic	—	-26	—	dBc
RF2 Harmonic Suppression			—	-26	—	dBc
IF Harmonic Suppression			—	-26	—	dBc
RFOUT Power Level		$Z_L = 50 \Omega$	-7	-2	1	dBm
IFOUT Power Level		$Z_L = 50 \Omega$	-10	-6	-3	dBm

Notes:

1. RF1 = 1.55 GHz, RF2 = 1.4 GHz, IF = 1080 MHz for all parameters unless otherwise noted.
2. From powerup request ($PWDN\uparrow$ or $SEN\uparrow$ during a write of 1 to bits PDIB and PDRB in Register 2) to RF and IF synthesizers ready (settled to within 0.1 ppm frequency error). Typical settling time to 5 degrees phase error is 120 μ s.
3. From powerdown request ($PWDN\downarrow$, or $SEN\uparrow$ during a write of 0 to bits PDIB and PDRB in Register 2) to supply current equal to I_{PWDN} .

Table 5. RF and IF Synthesizer Characteristics (Continued) $(V_{DD} = 2.7 \text{ to } 3.6 \text{ V}, T_A = -20 \text{ to } 85 \text{ }^\circ\text{C})$

Parameter ¹	Symbol	Test Condition	Min	Typ	Max	Unit
RF1 Reference Spurs		Offset = 200 kHz	—	-70	—	dBc
		Offset = 400 kHz	—	-75	—	dBc
		Offset = 600 kHz	—	-80	—	dBc
RF2 Reference Spurs		Offset = 200 kHz	—	-75	—	dBc
		Offset = 400 kHz	—	-80	—	dBc
		Offset = 600 kHz	—	-80	—	dBc
Powerup Request to Synthesizer Ready Time, RF1, RF2, IF ²	t_{pup}	Figures 5, 4	—	140	—	μs
Powerdown Request to Synthesizer Off Time ³	t_{pdn}	Figures 5, 4	—	—	100	ns

Notes:

- RF1 = 1.55 GHz, RF2 = 1.4 GHz, IF = 1080 MHz for all parameters unless otherwise noted.
- From powerup request ($\overline{\text{PWDN}}\uparrow$ or $\overline{\text{SEN}}\uparrow$ during a write of 1 to bits PDIB and PDRB in Register 2) to RF and IF synthesizers ready (settled to within 0.1 ppm frequency error). Typical settling time to 5 degrees phase error is 120 μs .
- From powerdown request ($\overline{\text{PWDN}}\downarrow$, or $\overline{\text{SEN}}\uparrow$ during a write of 0 to bits PDIB and PDRB in Register 2) to supply current equal to I_{PWDN} .

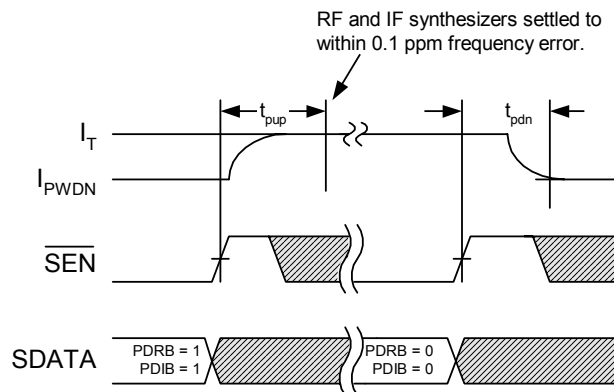
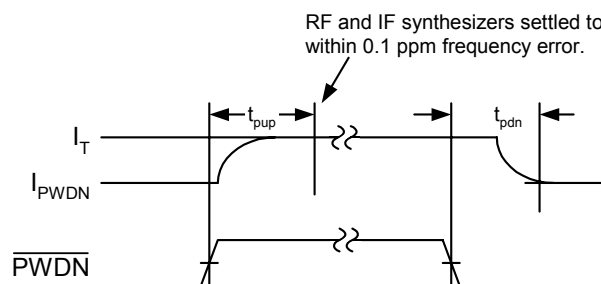
**Figure 4. Software Power Management Timing Diagram****Figure 5. Hardware Power Management Timing Diagram**

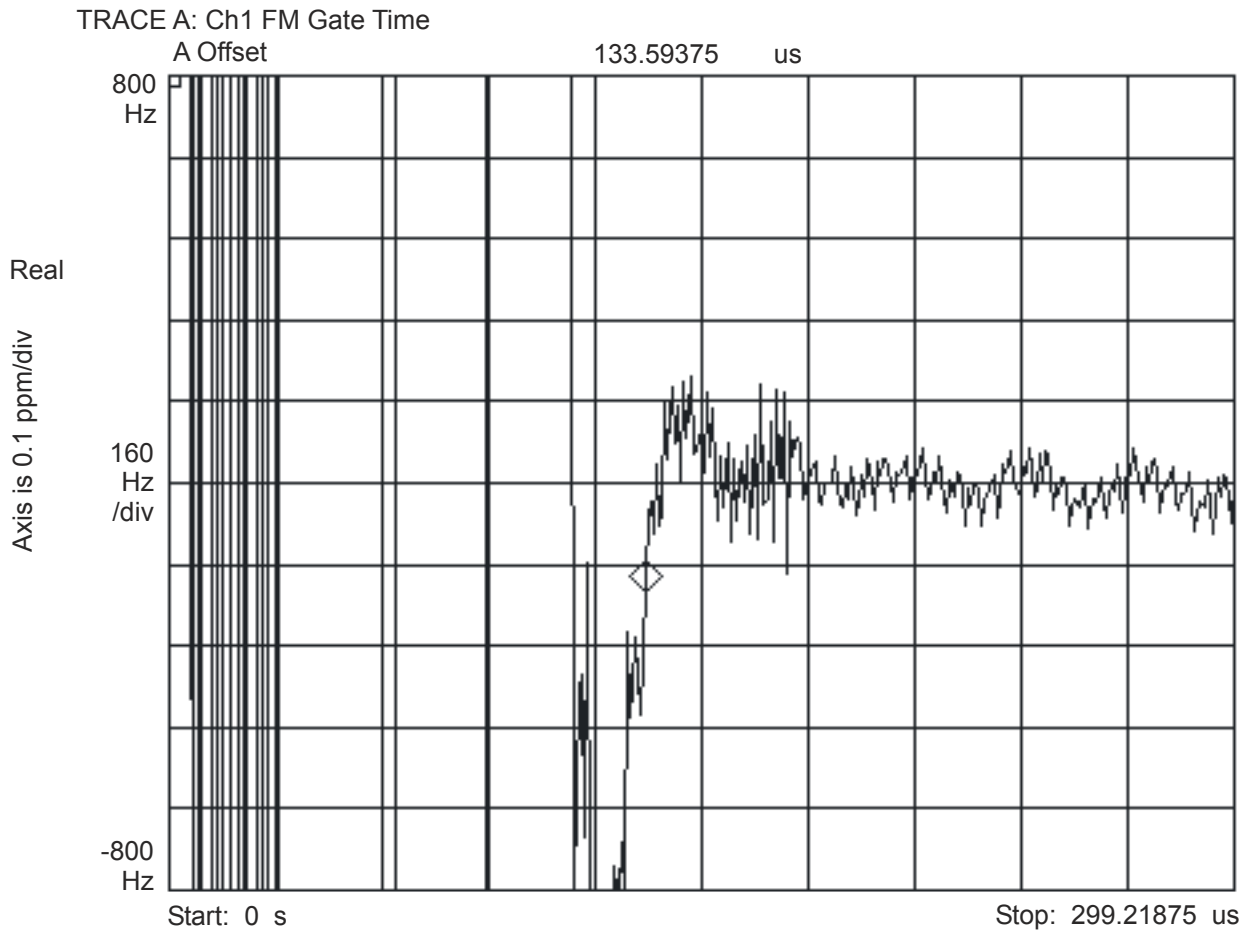

Figure 6. Typical Transient Response RF1 at 1.6 GHz with 200 kHz Phase Detector Update Frequency

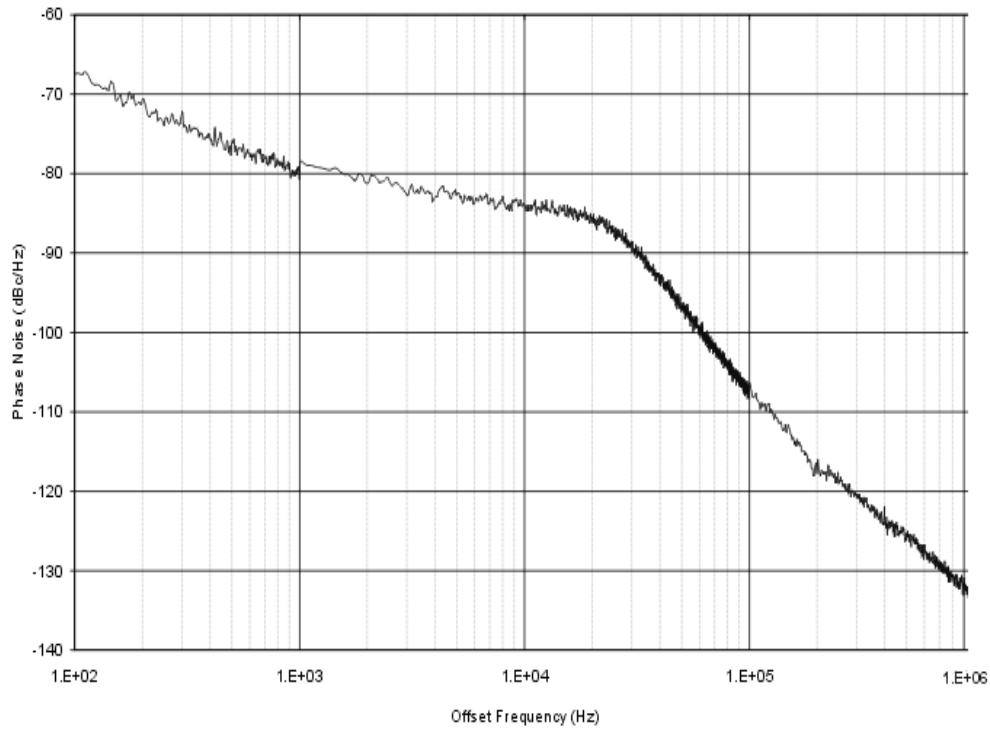

Figure 7. Typical RF1 Phase Noise at 1.6 GHz with 200 kHz Phase Detector Update Frequency

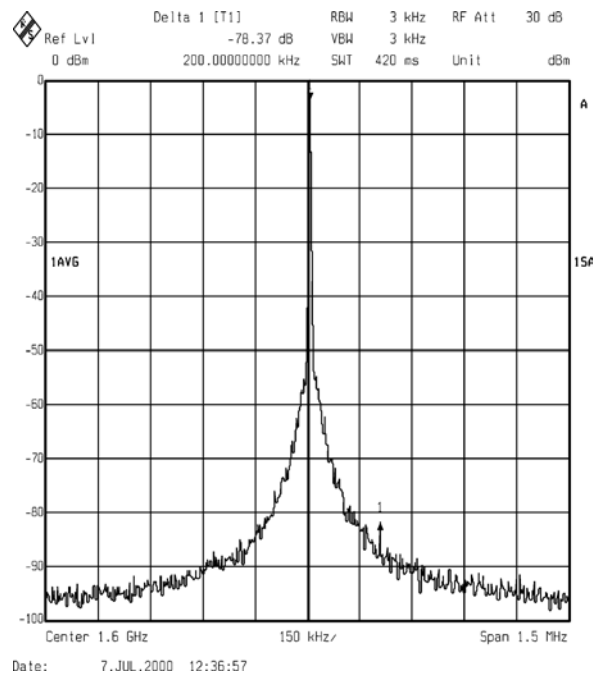

Figure 8. Typical RF1 Spurious Response at 1.6 GHz with 200 kHz Phase Detector Update Frequency

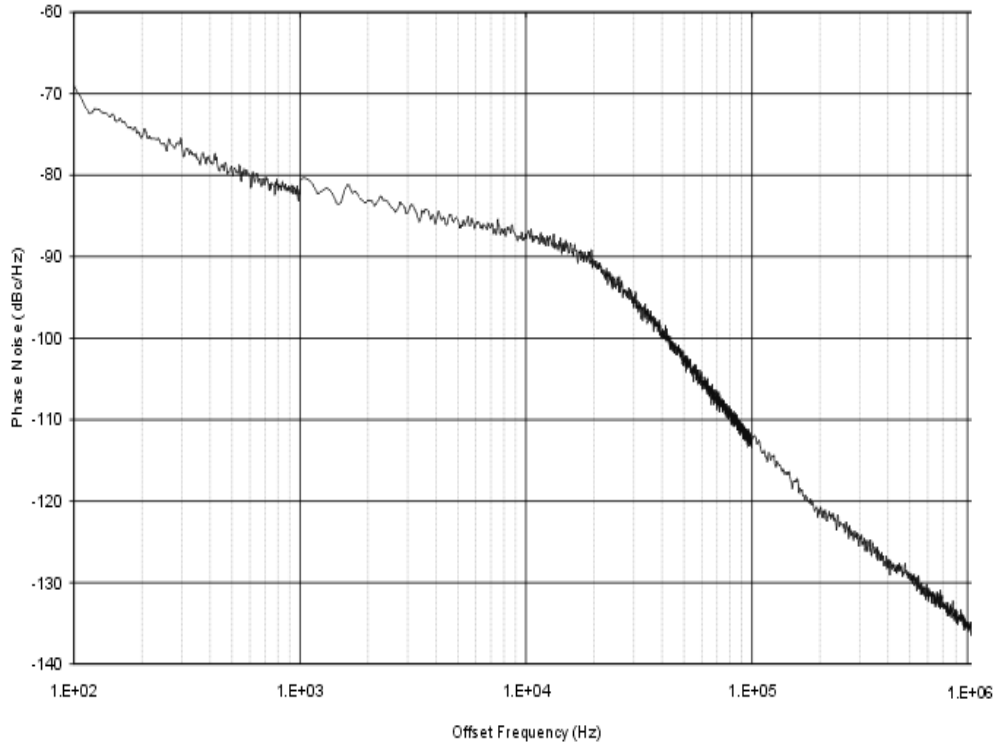

Figure 9. Typical RF2 Phase Noise at 1.2 GHz with 200 kHz Phase Detector Update Frequency

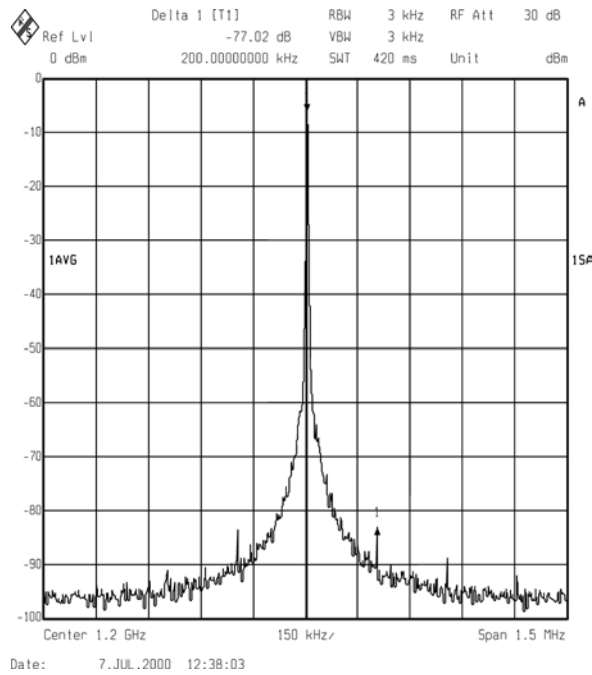

Figure 10. Typical RF2 Spurious Response at 1.2 GHz with 200 kHz Phase Detector Update Frequency

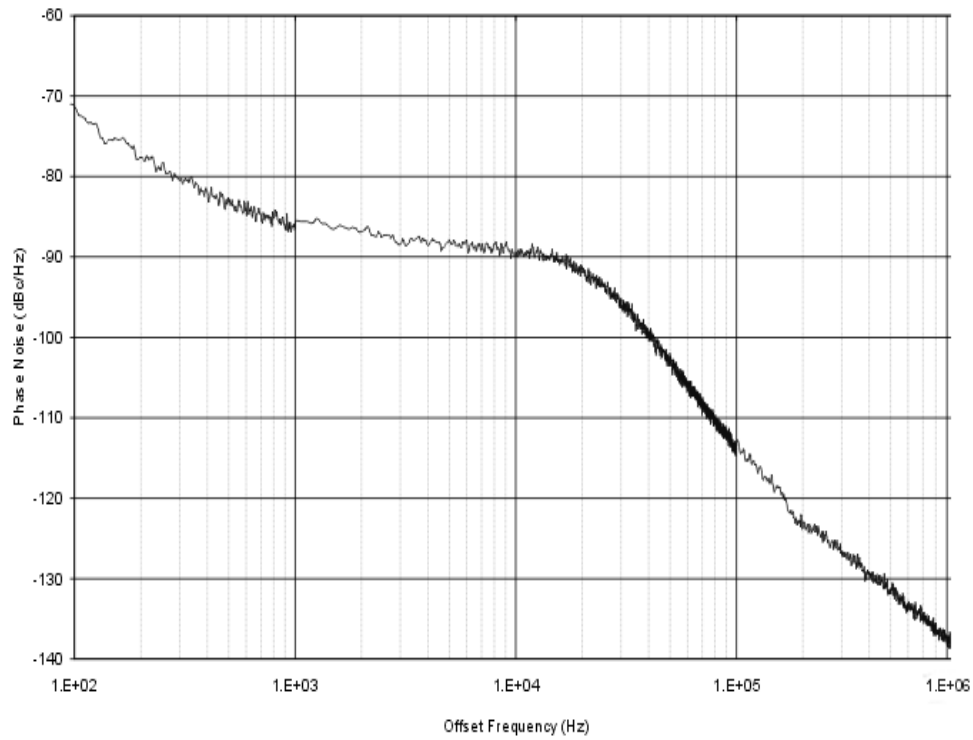

Figure 11. Typical IF Phase Noise at 1080 MHz with 200 kHz Phase Detector Update Frequency

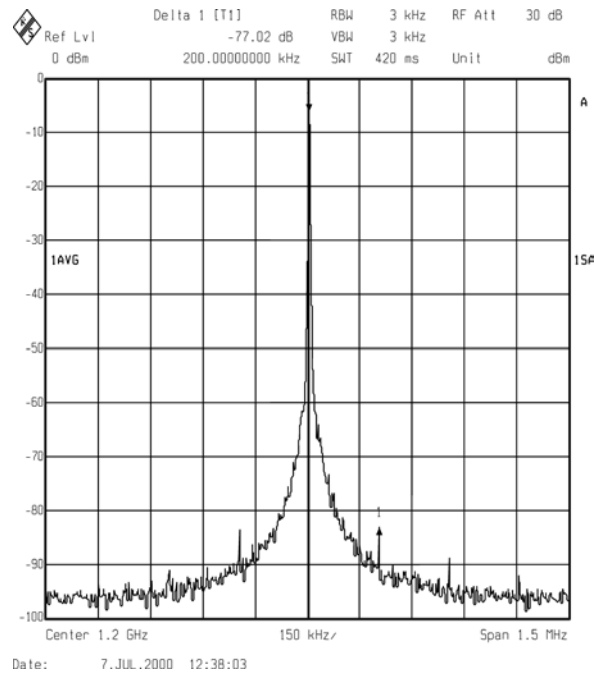

Figure 12. IF Spurious Response at 1080 MHz with 200 kHz Phase Detector Update Frequency

Si4133G-X2

Typical Application Circuits

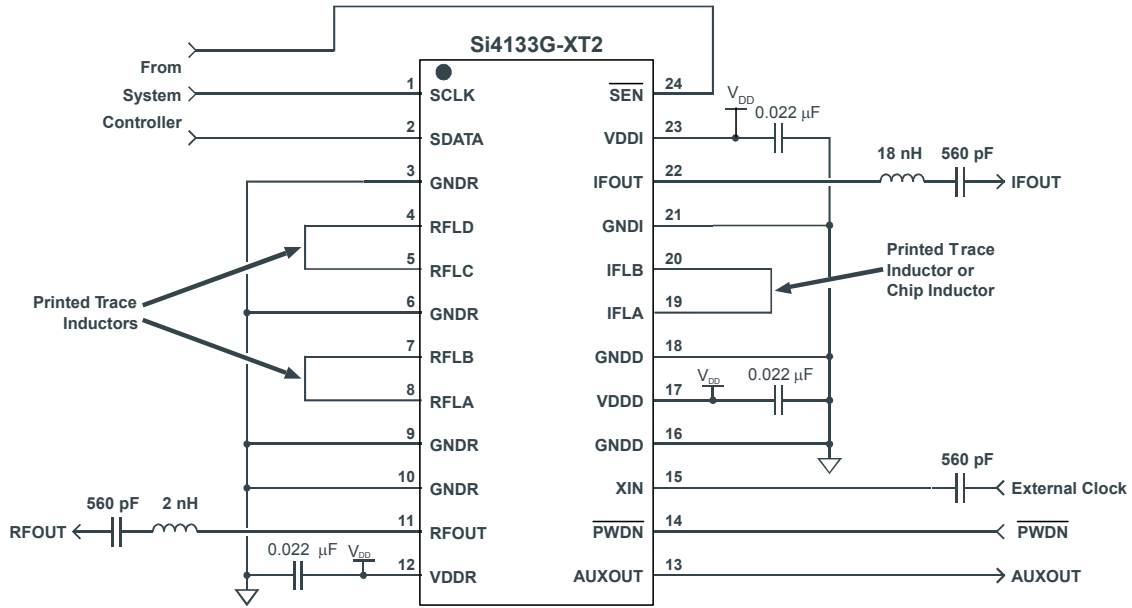

Figure 13. Si4133G-XT2

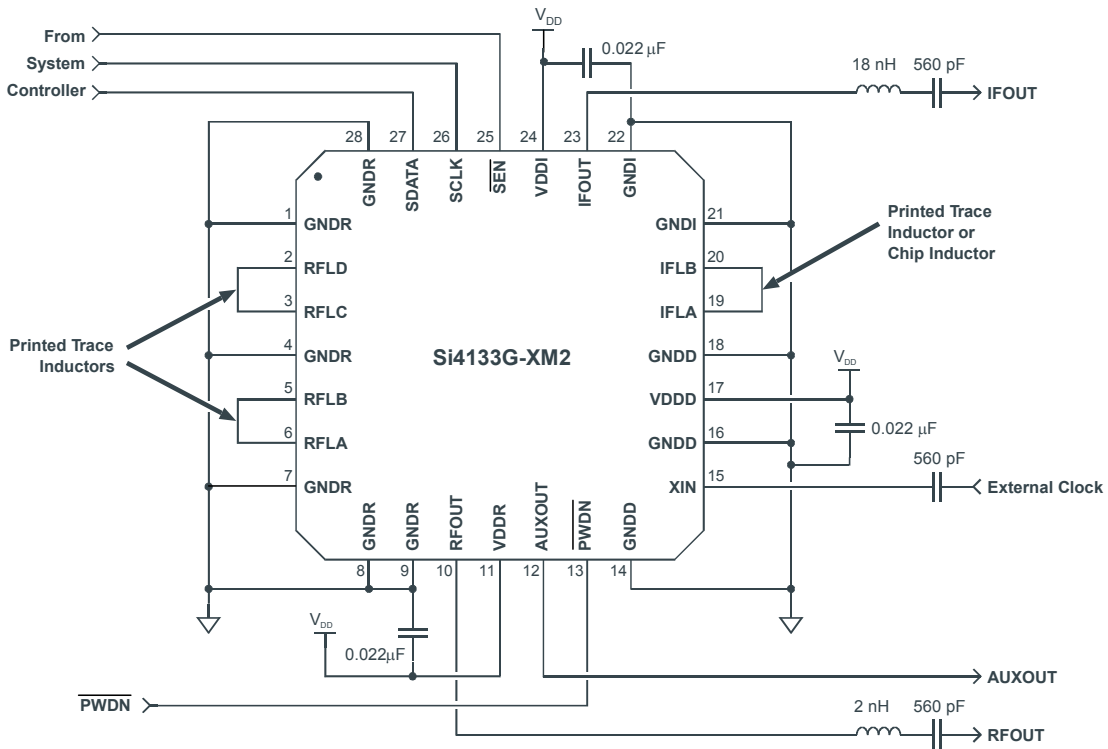

Figure 14. Si4133G-XM2

Functional Description

The Si4133G-X2 is a monolithic integrated circuit that performs IF and dual-band RF synthesis for many wireless applications such as GSM 850, E-GSM 900, DCS 1800, and PCS 1900. Its fast transient response also makes the Si4133G-X2 especially well suited to GPRS and HSCSD multislot applications where channel switching and settling times are critical. This integrated circuit (IC), with a minimum number of external components, is all that is necessary to implement the frequency synthesis function.

The Si4133G-X2 has three complete phase-locked loops (PLLs) with integrated voltage-controlled oscillators (VCOs). The low phase noise of the VCOs makes the Si4133G-X2 suitable for use in demanding cellular applications. Phase detectors, loop filters, and reference dividers are also integrated. The IC is programmed through a three-wire serial interface.

One PLL is provided for IF synthesis, and two PLLs are provided for dual-band RF synthesis. One RF VCO is optimized to have its center frequency set between 947 and 1720 MHz, whereas the second RF VCO is optimized to have its center frequency set between 789 and 1429 MHz. Each RF PLL can adjust its output frequency by $\pm 5\%$ relative to its VCO's center frequency. The IF VCO is optimized to have its center frequency set to 1080 MHz. Three settings are provided for IF output frequencies of 1070.4, 1080 and 1089.6 MHz.

The center frequency of each of the three VCOs is set by the connection of an external inductance. Inaccuracies in the value of the inductance are compensated for by the Si4133G-X2's proprietary self-tuning algorithm. This algorithm is initiated each time the PLL is powered-up (by either the $\overline{\text{PWDN}}$ pin or by software) and/or each time a new output frequency is programmed.

The two RF PLLs share a common output pin, so only one PLL is active at a time. Because the two VCOs can be set to have widely separated center frequencies, the RF output can be programmed to service different frequency bands, therefore the Si4133G-X2 ideal for use in dual-band cellular handsets.

The unique PLL architecture used in the Si4133G-X2 produces a transient response that is superior in speed to fractional-N architectures without suffering the high phase noise or spurious modulation effects often associated with those designs.

Serial Interface

The Si4133G-X2 is programmed serially with 22-bit words comprised of 18-bit data fields and 4-bit address fields. Figure 3 on page 7 shows the format of the serial interface. A timing diagram for the serial word is shown in Figure 2 on page 7.

When the serial interface is enabled (i.e., when $\overline{\text{SEN}}$ is low) data and address bits on the SDATA pin are clocked into an internal shift register on the rising edge of SCLK. Data in the shift register is then transferred on the rising edge of $\overline{\text{SEN}}$ into the internal data register addressed in the address field. The serial word is disabled when $\overline{\text{SEN}}$ is high.

Table 9 on page 19 summarizes the Data register functions and addresses. It is not necessary (although it is permissible) to clock into the internal shift register any leading bits that are "don't cares".

Setting the VCO Center Frequencies

The PLLs can adjust the IF and RF output frequencies $\pm 5\%$ with respect to their VCO center frequencies. Each center frequency is established by the value of an external inductance connected to the respective VCO. Manufacturing tolerances of $\pm 10\%$ for the external inductances are acceptable. The Si4133G-X2 compensates for inaccuracies in each inductance by executing a self-tuning algorithm following powerup or following a change in the programmed output frequency.

Because the total tank inductance is in the low nH range, the inductance of the package must be considered in determining the correct external inductance. The total inductance (L_{TOT}) presented to each VCO is the sum of the external inductance (L_{EXT}) and the package inductance (L_{PKG}). Each VCO has a nominal capacitance (C_{NOM}) in parallel with the total inductance, and the center frequency is as follows:

$$F_{\text{CEN}} = \frac{1}{2\pi\sqrt{L_{\text{TOT}} \times C_{\text{NOM}}}}$$

or

$$F_{\text{CEN}} = \frac{1}{2\pi\sqrt{(L_{\text{PKG}} + C_{\text{LEXT}}) \times C_{\text{NOM}}}}$$



Si4133G-X2

Tables 6 and 7 summarize these characteristics for each VCO.

Table 6. Si4133G-XT2 VCO Characteristics

VCO	f _{CEN} Range (MHz)		C _{NOM} (pF)	L _{PKG} (nH)	L _{EXT} Range (nH)	
	Min	Max			Min	Max
RF1	947	1720	4.3	2.0	0.0	4.6
RF2	789	1429	4.8	2.3	0.3	6.2
IF	1080		6.5	2.1	1.2	

Table 7. Si4133G-XM2 VCO Characteristics

VCO	f _{CEN} Range (MHz)		C _{NOM} (pF)	L _{PKG} (nH)	L _{EXT} Range (nH)	
	Min	Max			Min	Max
RF1	947	1720	4.3	1.5	0.5	5.1
RF2	789	1429	4.8	1.5	1.1	7.0
IF	1080		6.5	1.6	1.7	

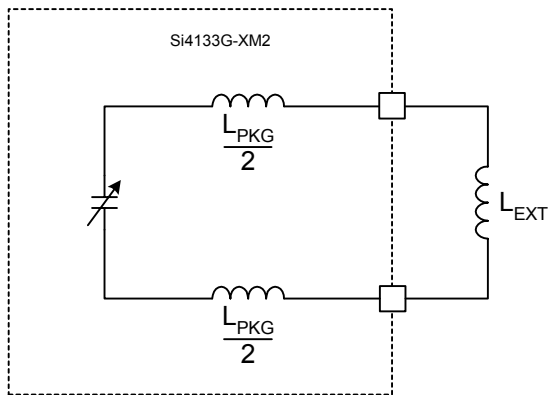

Figure 15. External Inductance Connection

As a design example, consider a design that is required to synthesize frequencies in a 25 MHz band between 1120 and 1145 MHz. The center frequency should be defined as midway between the two extremes, or 1132.5 MHz. The PLL can adjust the VCO output frequency $\pm 5\%$ of the center frequency, or ± 56.6 MHz of 1132.5 MHz (i.e., from approximately 1076 to 1189 MHz, more than enough for this example). The RF2 VCO has a C_{NOM} of 4.8 pF, and a 4.1 nH inductance in parallel with this capacitance yields the

required center frequency. An external inductance of 1.8 nH should be connected between RFLC and RFLD as shown in Figure 15. This, in addition to 2.3 nH of package inductance, presents the correct total inductance to the VCO. In manufacturing, the external inductance can vary $\pm 10\%$ of its nominal value and the Si4133G-X2 corrects for the variation with the self-tuning algorithm.

In most cases the requisite value of the external inductance is small enough to utilize a PC board trace. During initial board layout, a length of trace approximating the required inductance can be used. For more information, refer to AN31: Inductor Design for the Si41xx Synthesizer Family.

Self-Tuning Algorithm

The self-tuning algorithm is initiated immediately following powerup of a PLL or, if the PLL is already powered, following a change in its programmed output frequency. This algorithm attempts to tune the VCO so that its free-running frequency is near the required output frequency. The algorithm compensates for manufacturing tolerance errors in the value of the external inductance connected to the VCO. It also reduces the frequency error for which the PLL must correct to get precisely the required output frequency. The self-tuning algorithm leaves the VCO oscillating at a frequency in error by less than 1% of the required output frequency.

After self-tuning, the PLL controls the VCO oscillation frequency. The PLL completes frequency locking, eliminating remaining frequency error. From then on, it maintains frequency-lock, compensating for effects caused by temperature and supply voltage variations.

The Si4133G-X2's self-tuning algorithm compensates for component value errors at any temperature within the specified temperature range. However, the ability of the PLL to compensate for drift in component values that occur *after* self-tuning is limited. For external inductances with temperature coefficients approximately ± 150 ppm/ $^{\circ}$ C, the PLL can maintain lock for changes in temperature of approximately ± 30 $^{\circ}$ C.

Applications where the PLL is regularly powered down or switched between channels minimize or eliminate the potential effects of temperature drift because the VCO is re-tuned when it is powered up or when a new frequency is programmed. In applications where the ambient temperature can drift substantially after self-tuning, it may be necessary to monitor the LDET_B (lock-detect bar) signal on the AUXOUT pin to determine the locking state of the PLL. (See the AUXILIARY OUTPUT section below for how to select LDET_B.)

The LDET_B signal is low after self-tuning has completed but rises when either the IF or RF PLL nears the limit of its compensation range (LDET_B is also high when either PLL is executing the self-tuning algorithm). The output frequency is still locked when LDET_B goes high, but the PLL eventually loses lock if the temperature continues to drift in the same direction. Therefore, if LDET_B goes high both the IF and RF PLLs should promptly be re-tuned by initiating the self-tuning algorithm.

Output Frequencies

The IF and RF output frequencies are set by programming the N-Divider registers. Each RF PLL has its own N register and can be programmed independently. All three PLL R-dividers are fixed at R=65 to yield a 200 kHz phase detector update rate from a 13 MHz reference frequency. Programming the N-Divider register for either RF1 or RF2 automatically selects the associated output.

The reference frequency on the XIN pin is divided by R and this signal is input to the PLL's phase detector. The other input to the phase detector is the PLL's VCO output frequency divided by N. The PLL acts to make these frequencies equal. That is, after an initial transient

$$\frac{F_{\text{OUT}}}{N} = \frac{F_{\text{REF}}}{65}$$

or

$$F_{\text{OUT}} = \frac{N}{65} \times F_{\text{REF}}$$

For XIN = 13 MHz this simplifies to

$$F_{\text{OUT}} = N \times 200 \text{ kHz}$$

The integer N is set by programming the RF1 N-Divider register (Register 3), the RF2 N-Divider register (Register 4), and the IF N-Divider register (Register 5).

Each N-divider is implemented as a conventional high speed divider. That is, it consists of a dual-modulus prescaler, a swallow counter, and a lower speed synchronous counter. However, the calculation of these values is done automatically. Only the appropriate N value must be programmed

PLL Loop Dynamics

The transient response for each PLL is optimized for a GSM application. VCO gain, phase detector gain, and loop filter characteristics are not programmable.

The settling time for each PLL is directly proportional to its phase detector update period T_{ϕ} (T_{ϕ} equals $1/f_{\phi}$). For a GSM application with a 13 MHz reference frequency,

the RF and IF PLLs $T_{\phi} = 5 \mu\text{s}$. During the first 6.5 update periods, the Si4133G-X2 executes the self-tuning algorithm. Thereafter the PLL controls the output frequency. Because of the unique architecture of the Si4133G-X2 PLLs, the time required to settle the output frequency to 0.1 ppm error is approximately 21 update periods. Thus, the total time after powerup or a change in programmed frequency until the synthesized frequency is well settled (including time for self-tuning) is around 28 update periods or 140 μs .

RF and IF Outputs

The RFOUT and IFOUT pins are driven by amplifiers that buffer the RF VCOs and IF VCO, respectively. The RF output amplifier receives its input from either the RF1 or RF2 VCO, depending upon which N-Divider register was last written to. For example, programming the N-Divider register for RF1 automatically selects the RF1 VCO output.

The RFOUT pin must be coupled to its load through an ac coupling capacitor. A matching network is required to maximize power delivered into a 50 Ω load. The network consists of a 2 nH series inductance, which can be realized with a PC board trace, connected between the RFOUT pin and the ac coupling capacitor.

The network is made to provide an adequate match to an external 50 Ω load for both the RF1 and RF2 frequency bands. The matching network also filters the output signal to reduce harmonic distortion. A 50 Ω load is not required for proper operation of the Si4133G-X2. Depending on transceiver requirements, the matching network may not be required. See Figure 16 below.

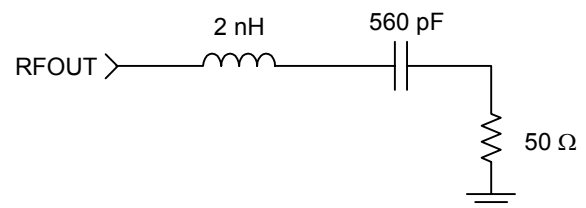

Figure 16. RFOUT 50 Ω Test Circuit

The IFOUT pin must also be coupled to its load through an ac coupling capacitor. A matching network is also required to drive a 50 Ω load. See Figure 17 below.

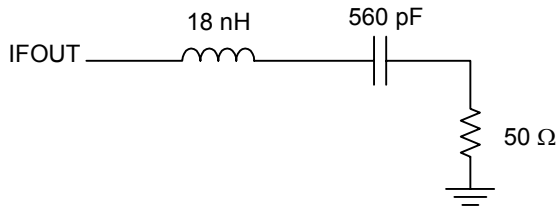

Figure 17. IFOUT 50 Ω Matching Network

Reference Frequency Amplifier

The Si4133G-X2 provides a reference frequency amplifier. If the driving signal has CMOS levels it can be connected directly to the XIN pin. Otherwise, the reference frequency signal should be ac coupled to the XIN pin through a 560 pF capacitor.

Powerdown Modes

Table 8 summarizes the powerdown functionality. The Si4133G-X2 can be powered down by taking the $\overline{\text{PWDN}}$ pin low or by setting bits in the Powerdown register (Register 2). When the $\overline{\text{PWDN}}$ pin is low, the Si4133G-X2 is powered down regardless of the Powerdown register settings. When the $\overline{\text{PWDN}}$ pin is high, power management is under control of the Powerdown register bits.

The reference frequency amplifier, IF, and RF sections of the Si4133G-X2 circuitry can be individually powered down by setting the Powerdown register bits PDIB and PDRB low, respectively. The reference frequency amplifier is also powered up if the PDRB and PDIB bits are high. Also, setting the AUTOPDB bit to 1 in the Main Configuration register (Register 0) is equivalent to setting both bits in the Powerdown register to 1. The serial interface remains available and can be written in all powerdown modes.

Auxiliary Output (AUXOUT)

The signal appearing on AUXOUT is selected by setting the AUXSEL bits in the Main Configuration register (Register 0).

The LDET_B signal can be selected by setting the AUXSEL bits to 11. As discussed previously, this signal can be used to indicate that the IF or RF PLL is about to lose lock because of excessive ambient temperature drift and should be re-tuned. The LDET_B signal indicates a logical OR result if both IF and RF are simultaneously generating a signal.

Table 8. Powerdown Configuration

$\overline{\text{PWDN}}$ Pin	AUTOPDB	PDIB	PDRB	IF Circuitry	RF Circuitry
$\overline{\text{PWDN}} = 0$	x	x	x	OFF	OFF
$\overline{\text{PWDN}} = 1$	0	0	0	OFF	OFF
	0	0	1	OFF	ON
	0	1	0	ON	OFF
	0	1	1	ON	ON
	1	x	x	ON	ON

Control Registers

Table 9. Register Summary

Register	Name	Bit 17	Bit 16	Bit 15	Bit 14	Bit 13	Bit 12	Bit 11	Bit 10	Bit 9	Bit 8	Bit 7	Bit 6	Bit 5	Bit 4	Bit 3	Bit 2	Bit 1	Bit 0
0	Main Configuration	0	0	0	0	AUXSEL [1:0]		0	0	0	0	0	0	0	0	AUTO PDB	0	1	0
1	Reserved																		
2	Powerdown	0	0	0	0	0	0	0	0	0	0	0	0	0	0	0	0	PDIB	PDRB
3	RF1 N-Divider	N _{RF1} [17:0]																	
4	RF2 N-Divider	0	N _{RF2} [16:0]																
5	IF N-Divider	0	0	N _{IF} [15:0]															
6	Reserved																		
.																			
.																			
.																			
15	Reserved																		

Note: Registers 1 and 6–15 are reserved. Writes to these registers may result in unpredictable behavior. Any register not listed here is reserved and should not be written.

Si4133G-X2

Register 0. Main Configuration Address Field = A[3:0] = 0000

Bit	D17	D16	D15	D14	D13	D12	D11	D10	D9	D8	D7	D6	D5	D4	D3	D2	D1	D0
Name	0	0	0	0	AUXSEL [1:0]		0	0	0	0	0	0	0	0	AUTO PDB	0	1	0

Bit	Name	Function
17:14	Reserved	Program to zero.
13:12	AUXSEL[1:0]	Auxiliary Output Pin Definition. 00 = Reserved. 01 = Force output low. 10 = Reserved. 11 = Lock Detect—LDET _B .
11:4	Reserved	Program to zero.
3	AUTOPDB	Auto Powerdown 0 = Software powerdown is controlled by Register 2. 1 = Equivalent to setting all bits in Register 2 = 1.
2	Reserved	Program to zero.
1	Reserved	Program to one .
0	Reserved	Program to zero.

Register 2. Powerdown Address Field (A[3:0]) = 0010

Bit	D17	D16	D15	D14	D13	D12	D11	D10	D9	D8	D7	D6	D5	D4	D3	D2	D1	D0
Name	0	0	0	0	0	0	0	0	0	0	0	0	0	0	0	0	PDIB	PDRB

Bit	Name	Function
17:2	Reserved	Program to zero.
1	PDIB	Powerdown IF Synthesizer. 0 = IF synthesizer powered down. 1 = IF synthesizer on.
0	PDRB	Powerdown RF Synthesizer. 0 = RF synthesizer powered down. 1 = RF synthesizer on.

Register 3. RF1 N-Divider Address Field (A[3:0]) = 0011

Bit	D17	D16	D15	D14	D13	D12	D11	D10	D9	D8	D7	D6	D5	D4	D3	D2	D1	D0
Name	N _{RF1} [17:0]																	

Bit	Name	Function
17:0	N _{RF1} [17:0]	N-Divider for RF1 Synthesizer.

Register 4. RF2 N-Divider Address Field = A[3:0] = 0100

Bit	D17	D16	D15	D14	D13	D12	D11	D10	D9	D8	D7	D6	D5	D4	D3	D2	D1	D0
Name	0	N _{RF2} [16:0]																

Bit	Name	Function
17	Reserved	Program to zero.
16:0	N _{RF2} [16:0]	N-Divider for RF2 Synthesizer.

Register 5. IF N-Divider Address Field (A[3:0]) = 0101

Bit	D17	D16	D15	D14	D13	D12	D11	D10	D9	D8	D7	D6	D5	D4	D3	D2	D1	D0
Name	0	0	N _{IF} [15:0]															

Bit	Name	Function
17:16	Reserved	Program to zero.
15:0	N _{IF} [15:0]	N-Divider for IF Synthesizer. Only the following values are allowed (frequencies assume XIN is 13 MHz): 7150 = 1070.4 MHz 7215 = 1080.0 MHz 7280 = 1089.6 MHz

Si4133G-X2

Pin Descriptions: Si4133G-XT2

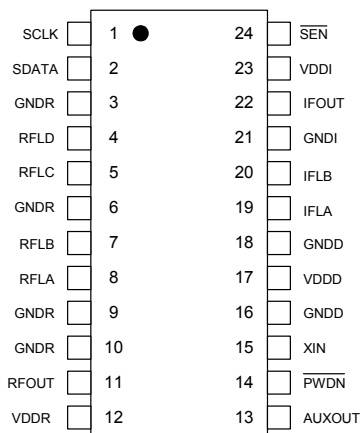

Pin Number	Name	Description
1	SCLK	Serial clock input
2	SDATA	Serial data input
3	GNDR	Common ground for RF analog circuitry
4	RFLD	Pins for inductor connection to RF2 VCO
5	RFLC	Pins for inductor connection to RF2 VCO
6	GNDR	Common ground for RF analog circuitry
7	RFLB	Pins for inductor connection to RF1 VCO
8	RFLA	Pins for inductor connection to RF1 VCO
9	GNDR	Common ground for RF analog circuitry
10	GNDR	Common ground for RF analog circuitry
11	RFOUT	Radio frequency (RF) output of the selected RF VCO
12	VDDR	Supply voltage for the RF analog circuitry
13	AUXOUT	Auxiliary output
14	PW $\overline{\text{DN}}$	Powerdown input pin
15	XIN	Reference frequency amplifier input
16	GNDD	Common ground for digital circuitry
17	VDDD	Supply voltage for digital circuitry
18	GNDD	Common ground for digital circuitry
19	IFLA	Pins for inductor connection to IF VCO
20	IFLB	Pins for inductor connection to IF VCO
21	GNDI	Common ground for IF analog circuitry
22	IFOUT	Intermediate frequency (IF) output of the IF VCO
23	VDDI	Supply voltage for IF analog circuitry
24	SEN	Enable serial port input

Pin Descriptions: Si4133G-XM2

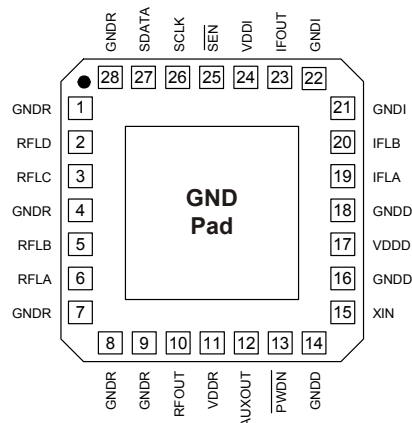

Pin Number	Name	Description
1	GNDR	Common ground for RF analog circuitry
2	RFLD	Pins for inductor connection to RF2 VCO
3	RFLC	Pins for inductor connection to RF2 VCO
4	GNDR	Common ground for RF analog circuitry
5	RFLB	Pins for inductor connection to RF1 VCO
6	RFLA	Pins for inductor connection to RF1 VCO
7	GNDR	Common ground for RF analog circuitry
8	GNDR	Common ground for RF analog circuitry
9	GNDR	Common ground for RF analog circuitry
10	RFOUT	Radio frequency (RF) output of the selected RF VCO
11	VDDR	Supply voltage for the RF analog circuitry
12	AUXOUT	Auxiliary output
13	PWDN	Powerdown input pin
14	GNDD	Common ground for digital circuitry
15	XIN	Reference frequency amplifier input
16	GNDD	Common ground for digital circuitry
17	VDDD	Supply voltage for digital circuitry
18	GNDD	Common ground for digital circuitry
19	IFLA	Pins for inductor connection to IF VCO
20	IFLB	Pins for inductor connection to IF VCO
21	GNDI	Common ground for IF analog circuitry
22	GNDI	Common ground for IF analog circuitry
23	IFOUT	Intermediate frequency (IF) output of the IF VCO
24	VDDI	Supply voltage for IF analog circuitry
25	SEN	Enable serial port input
26	SCLK	Serial clock input
27	SDATA	Serial data input
28	GNDR	Common ground for RF analog circuitry

Si4133G-X2

Ordering Guide

Ordering Part Number	Description	Package	Temperature
Si4133G-XM2	RF1/RF2/IF OUT	28-Pin MLP	-20 to 85 °C
Si4133G-XT2	RF1/RF2/IF OUT	24-Pin TSSOP	-20 to 85 °C

Package Outline: Si4133G-XT2

Figure 18 illustrates the package details for the Si4133G-XT2. Table 10 lists the values for the dimensions shown in the illustration.

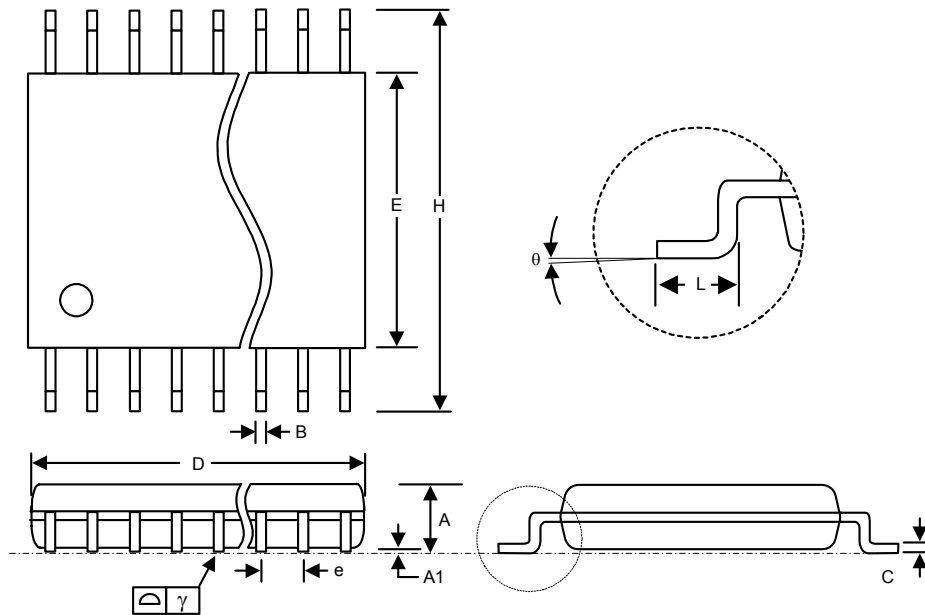

Approximate device weight is 115.7 mg.

Figure 18. 24-Pin Thin Shrink Small Outline Package (TSSOP)

Table 10. Package Diagram Dimensions

Symbol	Millimeters		Typical*
	Min	Max	
A	—	1.20	✓
A1	0.05	0.15	✓
B	0.19	0.30	
C	0.09	0.20	✓
D	7.70	7.90	
E	4.30	4.50	
e	0.65 BSC		
H	6.40 BSC		
L	0.45	0.75	
θ	0°	8°	✓
γ		0.10	
*Note: To guarantee coplanarity (γ), the parameters marked "Typical" may be exceeded.			

Si4133G-X2

Package Outline: Si4133G-XM2

Figure 19 illustrates the package details for the Si4133G-XM2. Table 11 lists the values for the dimensions shown in the illustration.

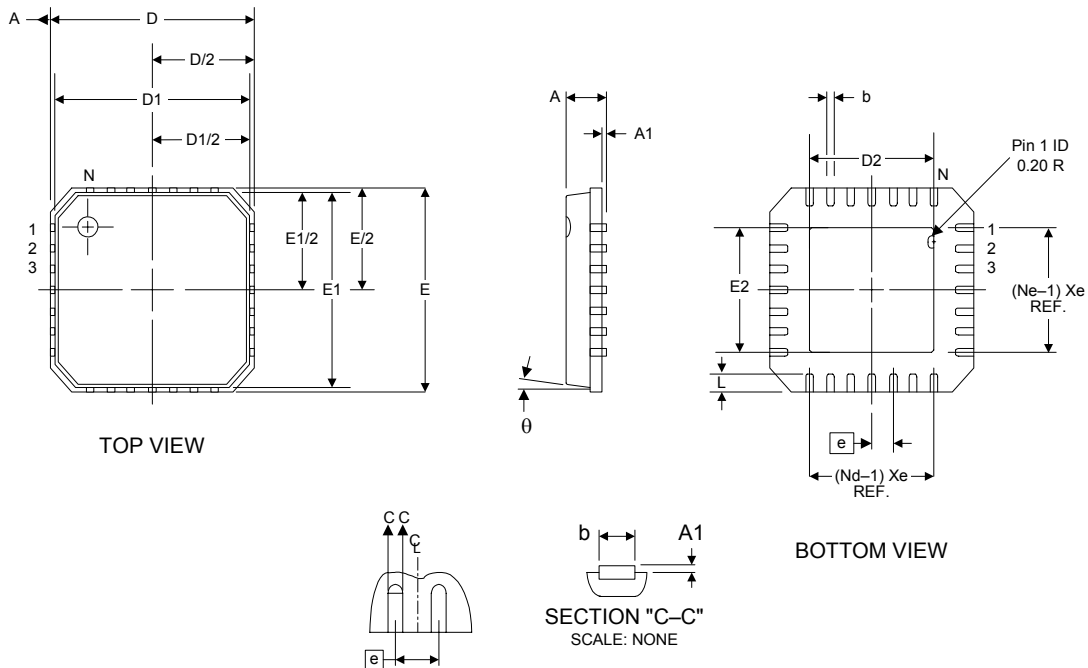

Figure 19. 28-Pin Micro Leadframe Package (MLP)

Table 11. Package Dimensions

Symbol	Millimeters		
	Min	Nom	Max
A	—	0.85	0.90
A1	0.00	0.01	0.05
b	0.18	0.23	0.30
D, E	5.00 BSC		
D1, E1	4.75 BSC		
D2	2.55	2.70	2.85
E2	2.55	2.70	2.85
N	28		
Nd	7		
Ne	7		
e	0.50 BSC		
L	0.50	0.60	0.75
θ			12°

Document Change List

Revision 1.1 to Revision 1.2

- TSSOP outline updated.

Si4133G-X2

Contact Information

Silicon Laboratories Inc.

4635 Boston Lane
Austin, Texas 78735
Tel: 1+ (512) 416-8500
Fax: 1+ (512) 416-9669
Toll Free: 1+ (877) 444-3032
Email: productinfo@silabs.com
Internet: www.silabs.com

The information in this document is believed to be accurate in all respects at the time of publication but is subject to change without notice. Silicon Laboratories assumes no responsibility for errors and omissions, and disclaims responsibility for any consequences resulting from the use of information included herein. Additionally, Silicon Laboratories assumes no responsibility for the functioning of undescribed features or parameters. Silicon Laboratories reserves the right to make changes without further notice. Silicon Laboratories makes no warranty, representation or guarantee regarding the suitability of its products for any particular purpose, nor does Silicon Laboratories assume any liability arising out of the application or use of any product or circuit, and specifically disclaims any and all liability, including without limitation consequential or incidental damages. Silicon Laboratories products are not designed, intended, or authorized for use in applications intended to support or sustain life, or for any other application in which the failure of the Silicon Laboratories product could create a situation where personal injury or death may occur. Should Buyer purchase or use Silicon Laboratories products for any such unintended or unauthorized application, Buyer shall indemnify and hold Silicon Laboratories harmless against all claims and damages.

Silicon Laboratories and Silicon Labs are trademarks of Silicon Laboratories Inc.
Other products or brandnames mentioned herein are trademarks or registered trademarks of their respective holders.

Looking for pricing, stock, or lifecycle information?

Click below to explore more details on WIN SOURCE:

 [View SI4133GX2-BM](#) on WIN SOURCE

 [Silicon Labs](#) Information

Optimize Your Supply Chain with WIN SOURCE Solutions

-  Global Sourcing Solution
-  Obsolete Management
-  Cost Control Management
-  Shortage Management
-  Alternative Solution
-  Excess Inventory Management