



**THE DATASHEET OF  
J114FL2AS824VDC.41**





## Features

- Switching capacity 16A
- Produced in accordance to IEC 60335-1
- PC board mounting
- UL/CUL certified

**UL**<sup>®</sup> US  
E197851



## Contact Data\*

Contact Arrangement	1A = SPST N.O.
	1C = SPDT
	2A = DPST N.O.
	2C = DPDT

Contact Resistance	< 50 milliohms initial
Contact Material	AgSnO <sub>2</sub>
Maximum Switching Power	480W, 4000VA
Maximum Switching Voltage	380VAC, 110VDC
Maximum Switching Current	16A

UL Electrical Rating			Coil Power
12A Contact Single Pole	NO	12A @ 250VAC; 30VDC, Resistive, 6K cycles, 85°C	.41W
	NC	12A @ 250VAC; 30VDC, Resistive, 6K cycles, 85°C	
16A Contact Single Pole	NO	16A @ 250VAC; 30VDC, Resistive, 6K cycles, 85°C 16A @ 277VAC, Resistive, 100K cycles, 105°C	.41W
	NC	16A @ 250VAC; 30VDC, Resistive, 6K cycles, 85°C	
8A Contact Double Pole	NO	8A @ 277VAC; 30VDC, Resistive, 6K cycles, 85°C	.41W
	NC	8A @ 277VAC; 30VDC, Resistive, 6K cycles, 85°C	
10A Contact Double Pole	NO	10A @ 250VAC, Resistive, 50K cycles, 85°C	.53W
	NC	10A @ 30VDC, Resistive, 10K cycles, 85°C	

## Coil Data\*

Coil Voltage VDC		Coil Resistance Ω +/- 10%		Pick Up Voltage VDC (max) 75% of rated voltage	Release Voltage VDC (min) 10% of rated voltage	Coil Power W	Operate Time ms	Release Time ms
Rated	Max	.41W	.53W					
5	6.5	62	47	3.75	.5	.41 .53	10	5
6	7.8	90	67	4.50	.6			
9	11.7	202	150	6.75	.9			
12	15.6	360	270	9.00	1.2			
24	31.2	1440	1050	18.00	2.4			
48	62.4	5760	4250	36.00	3.6			



**Dimensions - 12amp Single Pole**

Units = mm

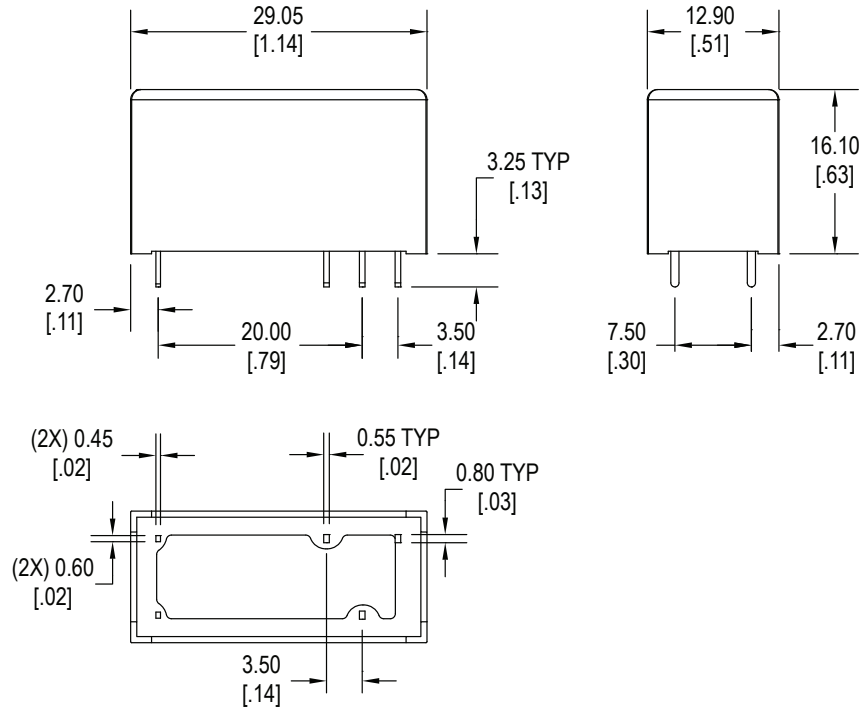

**Dimensions - 16amp Single Pole, 8amp Double Pole, 10amp Double Pole**

Units = mm

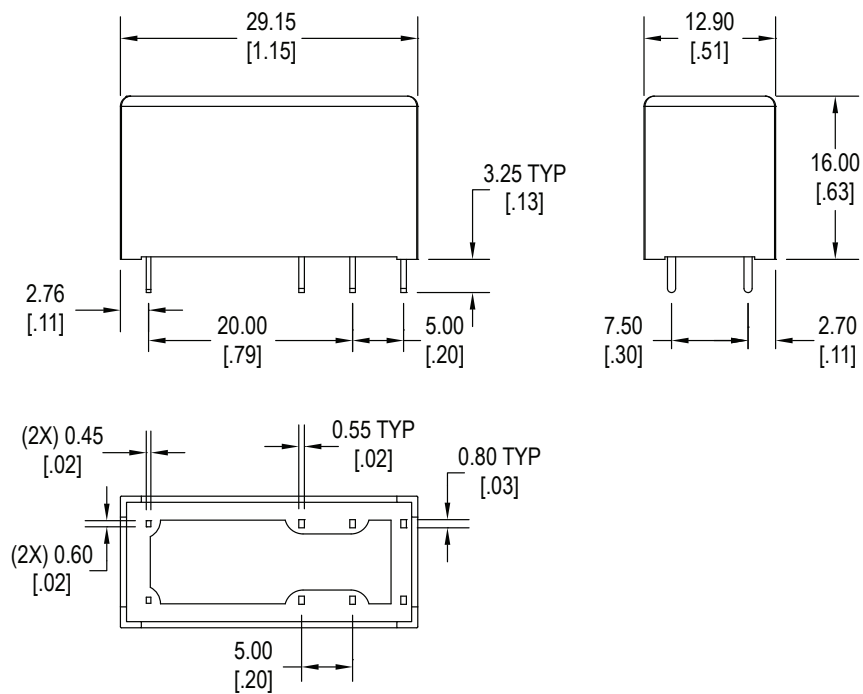

## Schematics & PC Layouts

### Bottom Views

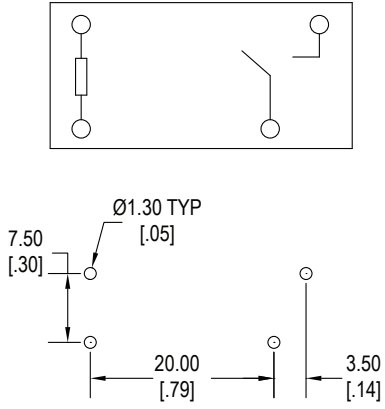

**1A (12amp)**

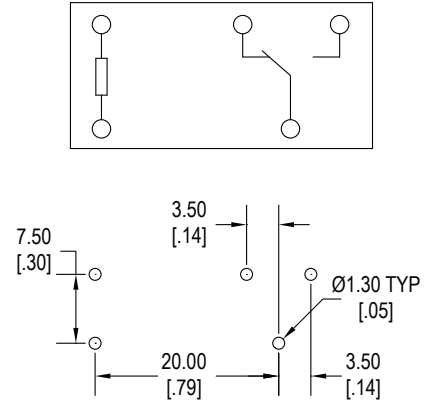

**1C (12amp)**

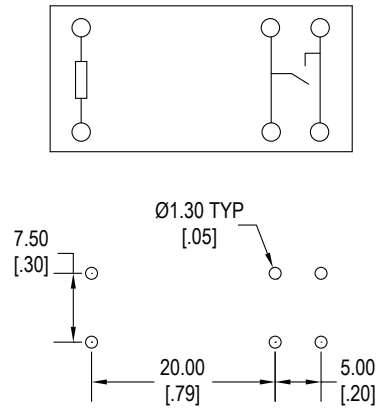

**1A (16amp)**

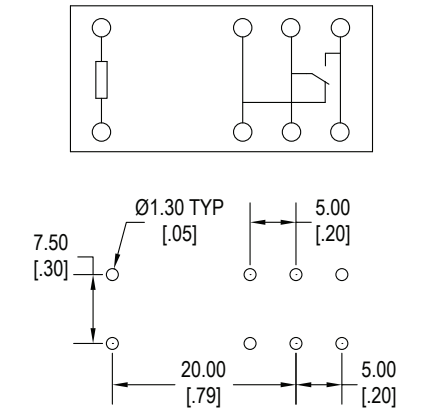

**1C (16amp)**

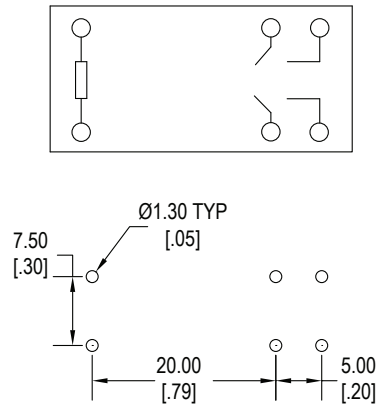

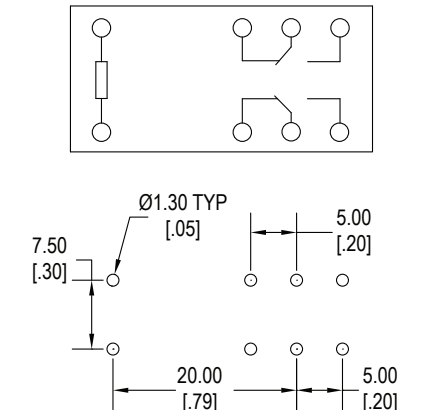

**2A (8amp, 10amp)**



**2C (8amp, 10amp)**

## Looking for pricing, stock, or lifecycle information?

Click below to explore more details on WIN SOURCE:

-  [View J114FL2AS824VDC.41 on WIN SOURCE](#)
-  [CIT Relay & Switch Information](#)

## Optimize Your Supply Chain with WIN SOURCE Solutions

-  Global Sourcing Solution
-  Obsolete Management
-  Cost Control Management
-  Shortage Management
-  Alternative Solution
-  Excess Inventory Management