



**THE DATASHEET OF
FMER-G62R-J017**



Filter for DC systems and photovoltaic converters



See below:

Approvals and Compliances

Description

- High-power DC filter for rated currents up to 2300 A
- 1-stage
- Very high attenuation
- Versions with or without capacitors to ground

Unique Selling Proposition

- Compact filter for high power
- Suitable for high voltages up to 1500 VDC
- Light weight design
- Wide temperature range

Applications

- Voltage up to 1500 VDC for world wide acceptance
- UL approved 1000VDC, 250 - 2300A and 600VDC, 25 - 150A
- Standard versions 1200 VDC
- Suitable for energy applications such as photovoltaic systems, energy storage systems and powerful EV charging systems
- Helps to meet international EMC standardsProtects the PV-modules from the inverter emissions

Other versions on request

- 1500 VDC versions

References

Weblinks

[pdf data sheet](#), [html datasheet](#), [General Product Information](#), [Approvals](#), [Distributor-Stock-Check](#), [Detailed request for product](#), [Microsite](#)

Technical Data

Rated Current	25 - 2300 (1200)A @ Ta 55 (75)°C
Rated voltage	1200VDC MAX.
Approval for	25 - 2300A @ Ta 55 °C / 1200VDC
Overload Current	1.5 x Ir for 1 minute, per hour
Number of Filter Stages	1-stage
Weight	1 - 32 kg
Material: Housing	Metal
Sealing Compound	UL 94V-0

Mounting	Screw-on mounting on chassis, from top
Terminal	Screw clamps for types up to 150 A and copper bars for types upwards of 250 A.
Operating Temperature	-40°C to 100°C
Climatic Category	40/100/21 acc. to IEC 60068-1
Degree of Protection	IP20 (25A-150A types), IP00 (250A-2300A types) acc. to IEC 60529
Protection Class	Suitable for appliances with protection class I acc. to IEC 61140

Approvals and Compliances

Detailed information on product approvals, code requirements, usage instructions and detailed test conditions can be looked up in [Details about Approvals](#)

SCHURTER products are designed for use in industrial environments. They have approvals from independent testing bodies according to national and international standards. Products with specific characteristics and requirements such as required in the automotive sector according to IATF 16949, medical technology according to ISO 13485 or in the aerospace industry can be offered exclusively with customer-specific, individual agreements by SCHURTER.

Approvals



The approval mark is used by the testing authorities to certify compliance with the safety requirements placed on electronic products.

Approval Reference Type: FMER SOL

Approval Logo	Certificates	Certification Body	Description
	UL Approvals	UL	UR File Number: E72928

Product standards

Product standards that are referenced

Organization	Design	Standard	Description
	Designed according to	IEC 60939	Passive filters for suppressing electromagnetic interference
	Designed according to	UL 1283	Passive filters for suppressing electromagnetic interference





Application standards

Application standards where the product can be used

Organization	Design	Standard	Description
	Suitable for applications acc.	IEC/UL 62368-1	Audio/video, information and communication technology equipment - Part 1: Safety requirements

Compliances

The product complies with following Guide Lines

Identification	Details	Initiator	Description
	CE declaration of conformity	SCHURTER AG	The CE marking declares that the product complies with the applicable requirements laid down in the harmonisation of Community legislation on its affixing in accordance with EU Regulation 765/2008.
	UKCA declaration of conformity	SCHURTER AG	The UKCA marking declares that the product complies with the applicable requirements laid down in the British Amendment of Regulation (EC) 765/2008.
	RoHS	SCHURTER AG	Directive RoHS 2011/65/EU, Amendment (EU) 2015/863
	China RoHS	SCHURTER AG	The law SJ / T 11363-2006 (China RoHS) has been in force since 1 March 2007. It is similar to the EU directive RoHS.
	REACH	SCHURTER AG	On 1 June 2007, Regulation (EC) No 1907/2006 on the Registration, Evaluation, Authorization and Restriction of Chemicals 1 (abbreviated as "REACH") entered into force.

Dimension [mm]

Case 2P

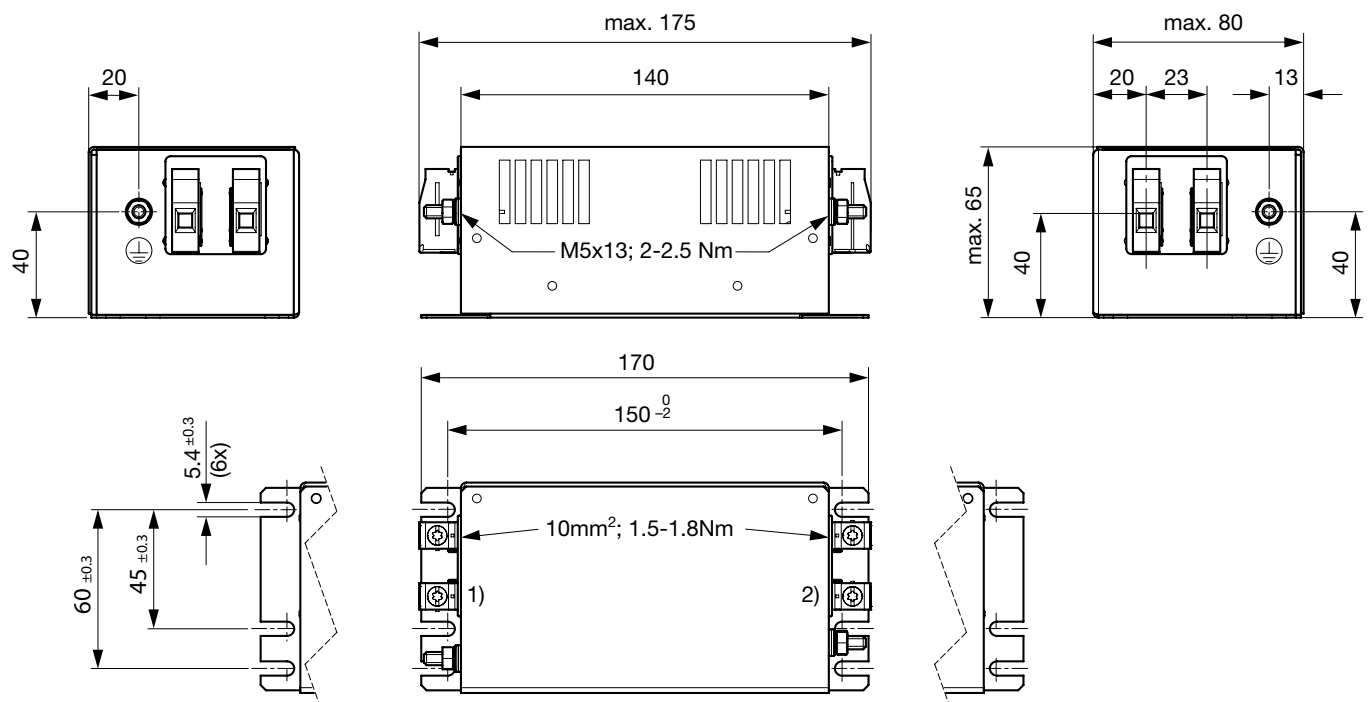

- 1) PV module
- 2) Inverter

Case 2Q

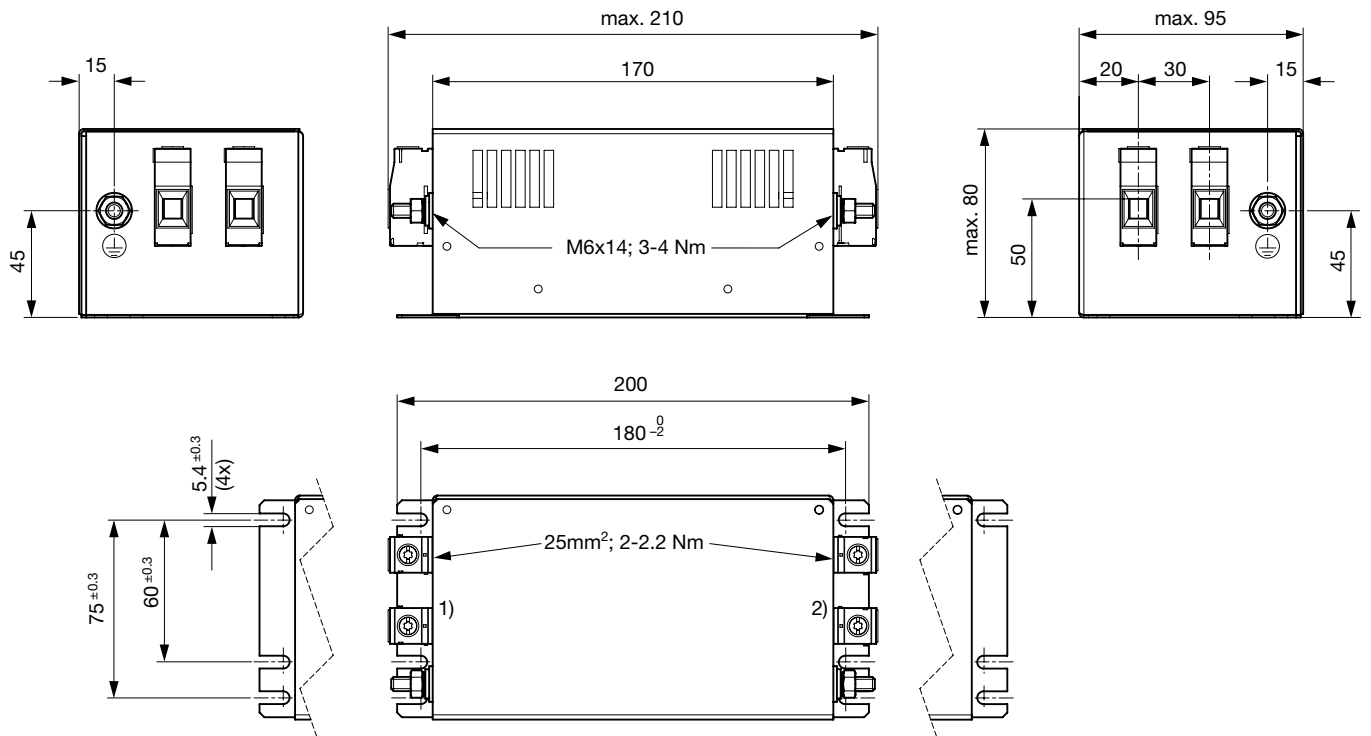

- 1) PV module
- 2) Inverter

Case 2R

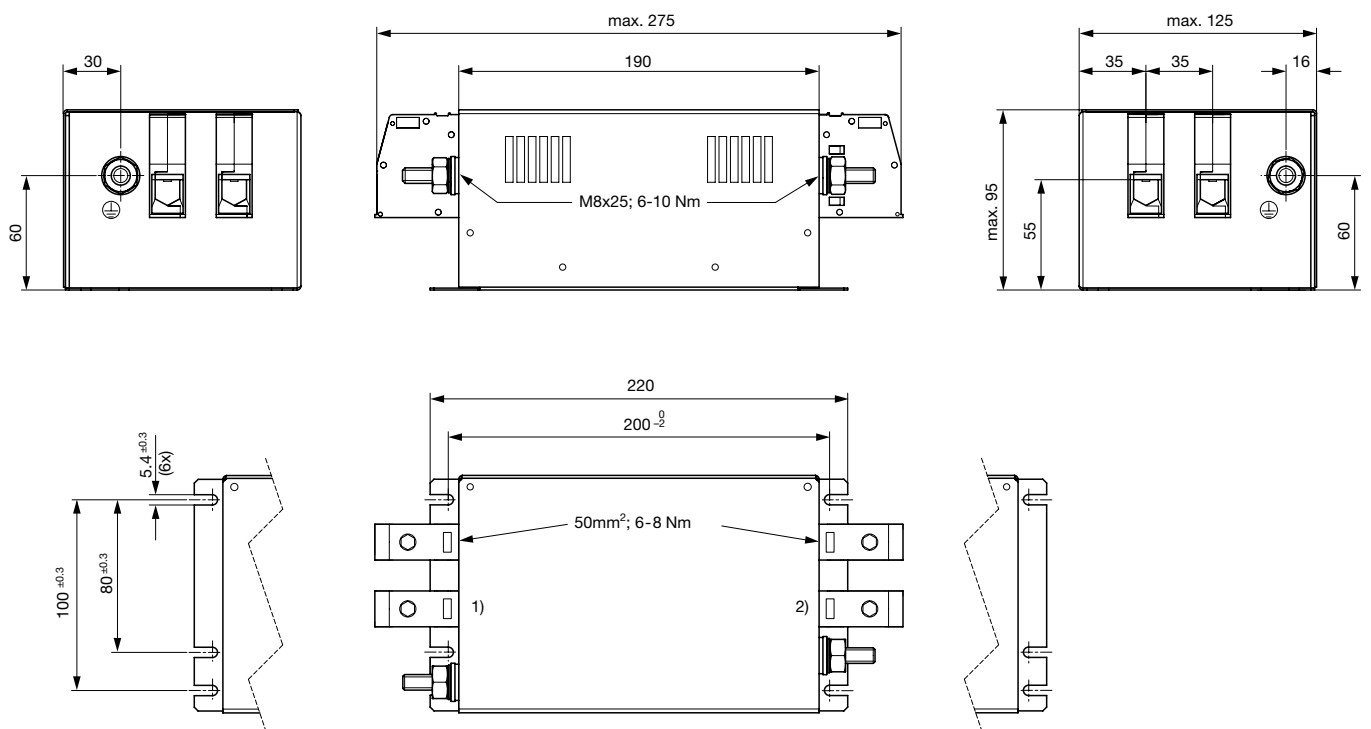

- 1) PV module
- 2) Inverter

Case 2S

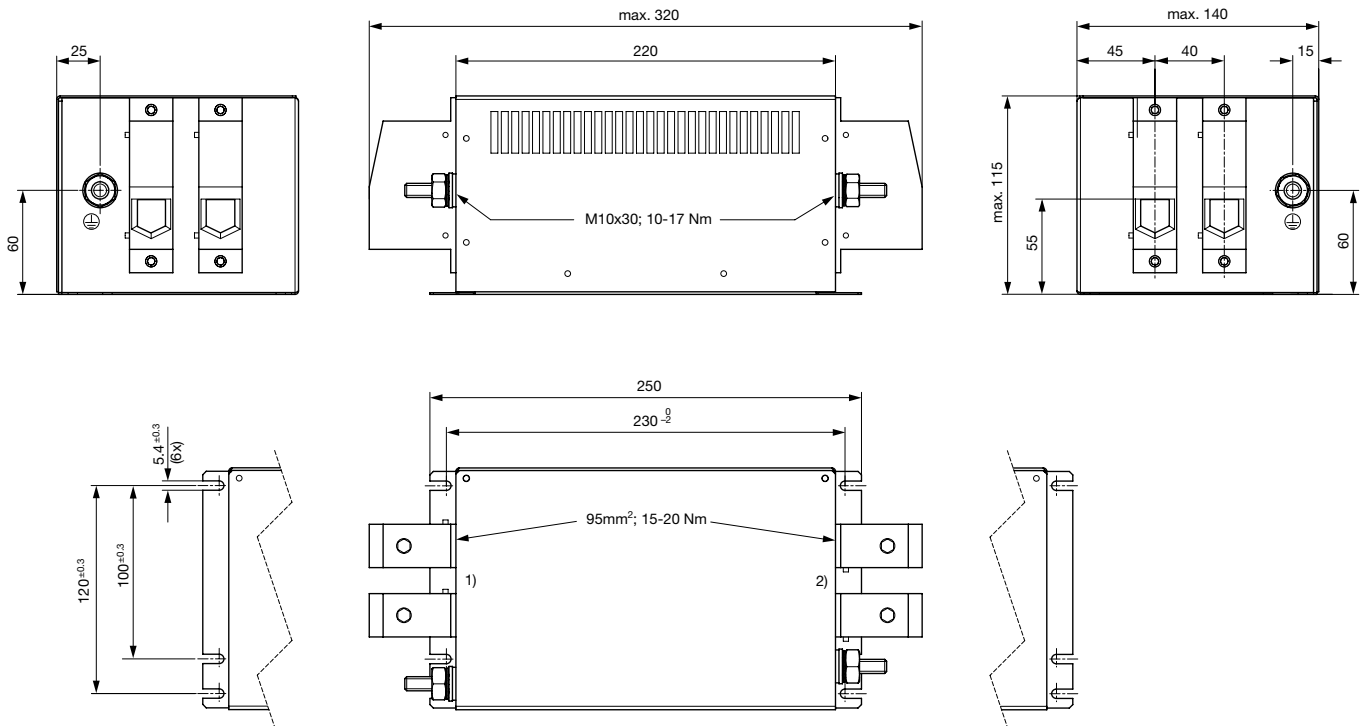

- 1) PV module
- 2) Inverter

Case 2T

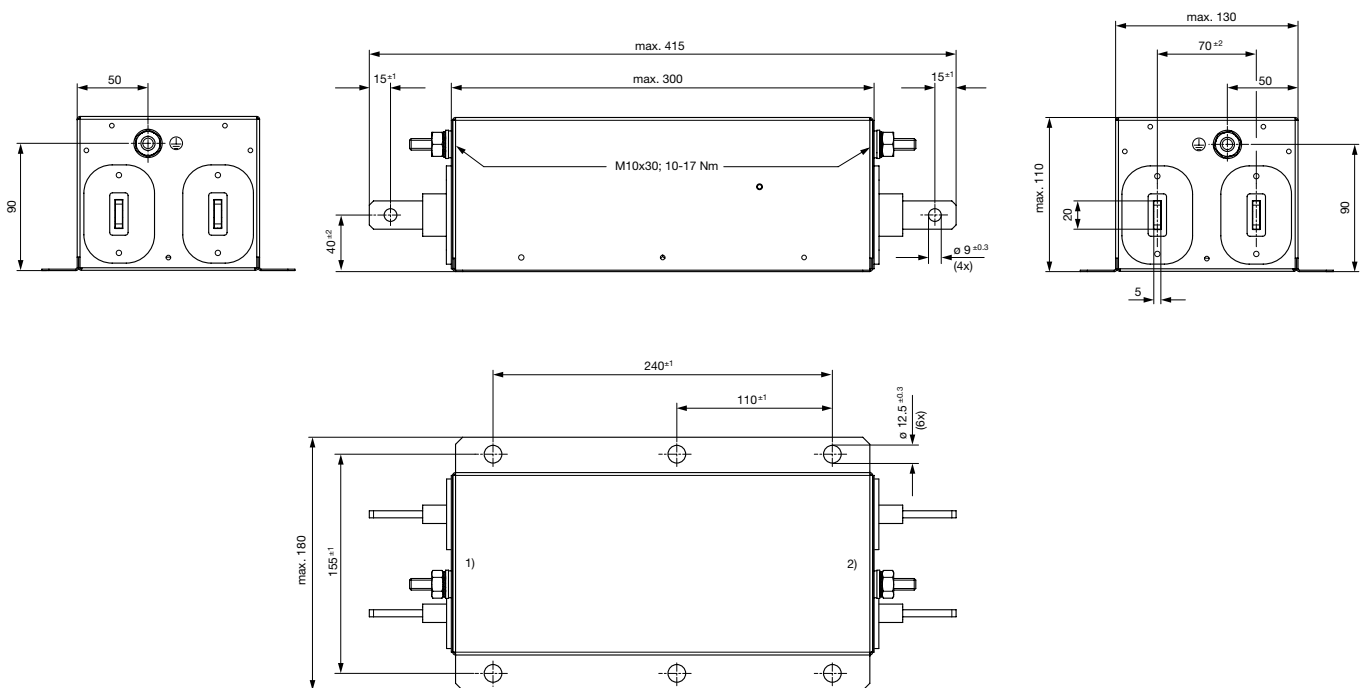

- 1) PV module
- 2) Inverter

Case 2U1

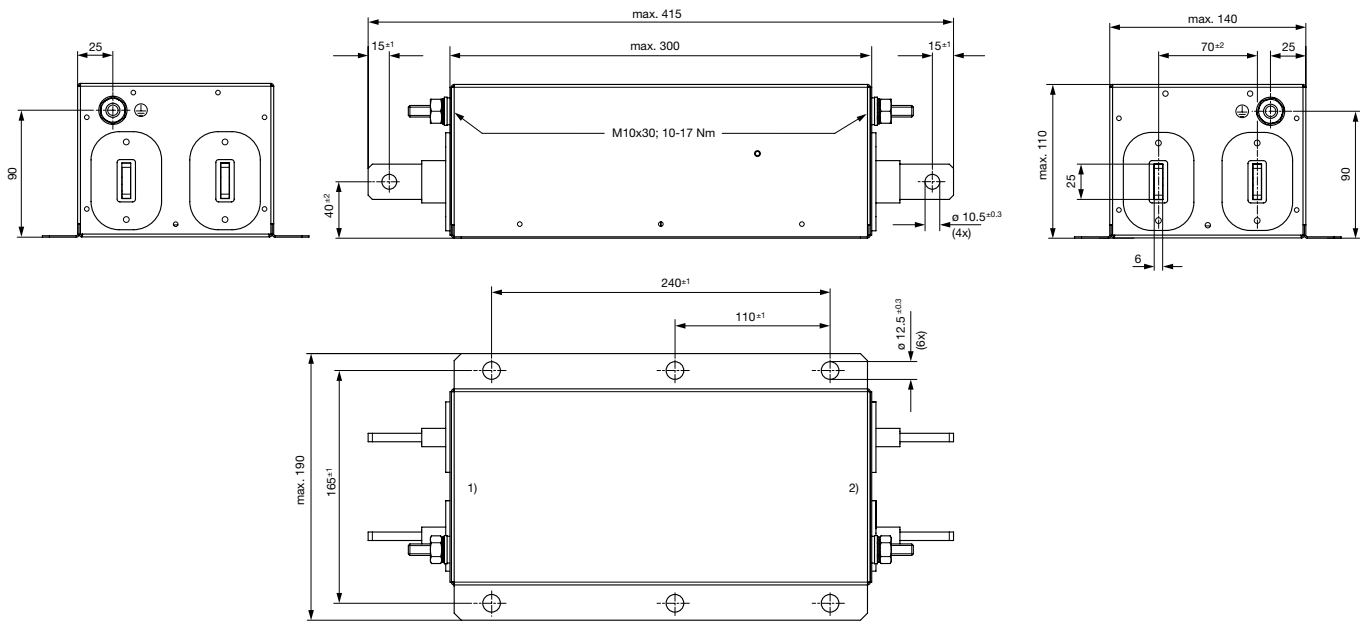

- 1) PV module
 - 2) Inverter
- Case 2U2

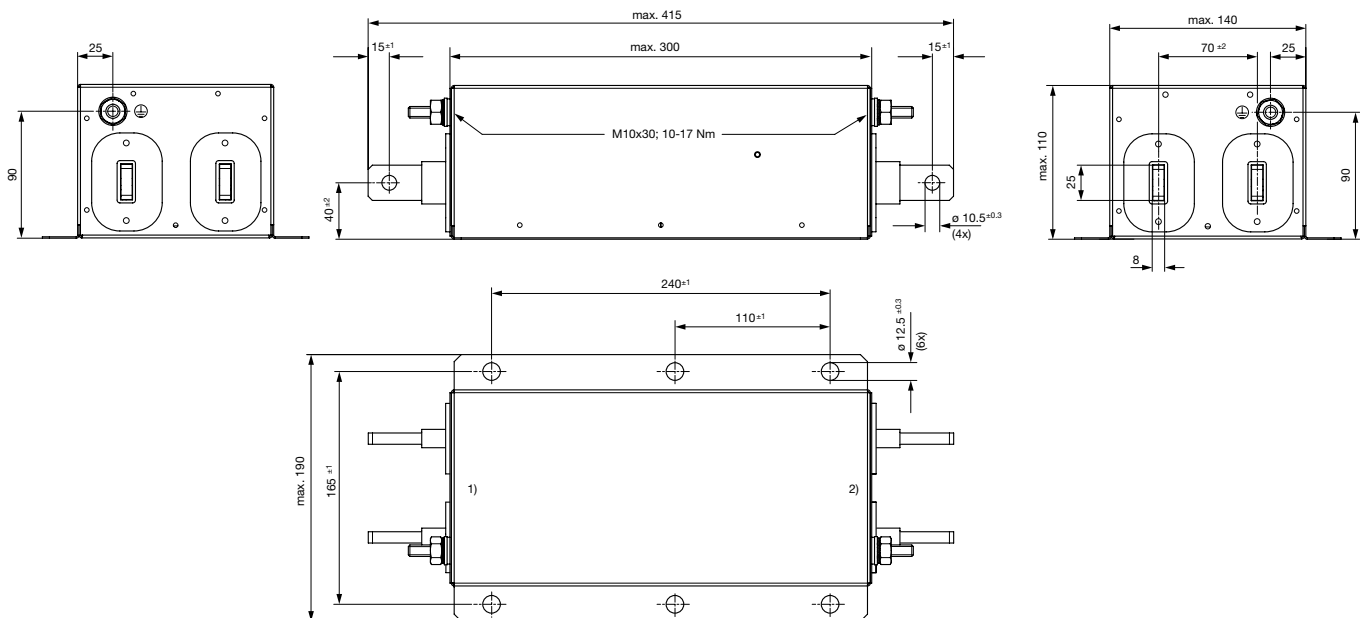

- 1) PV module
- 2) Inverter

Case 2V

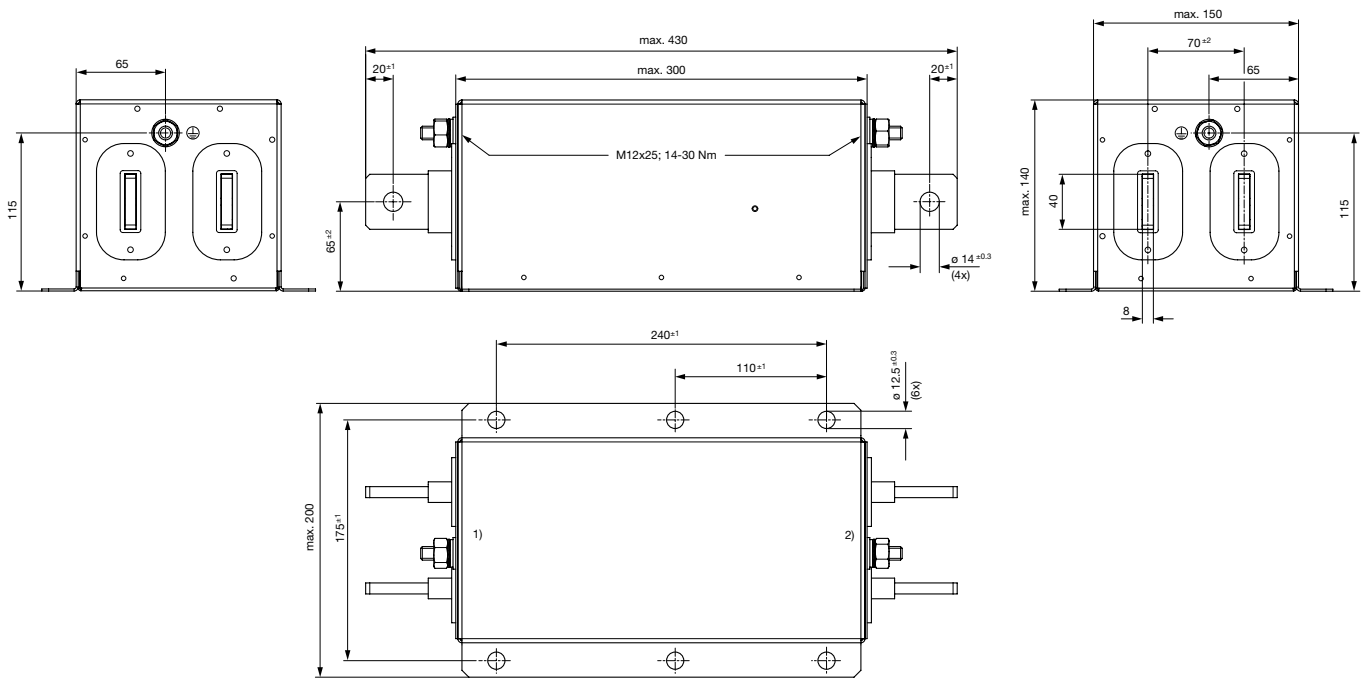

- 1) PV module
- 2) Inverter

Case 2W

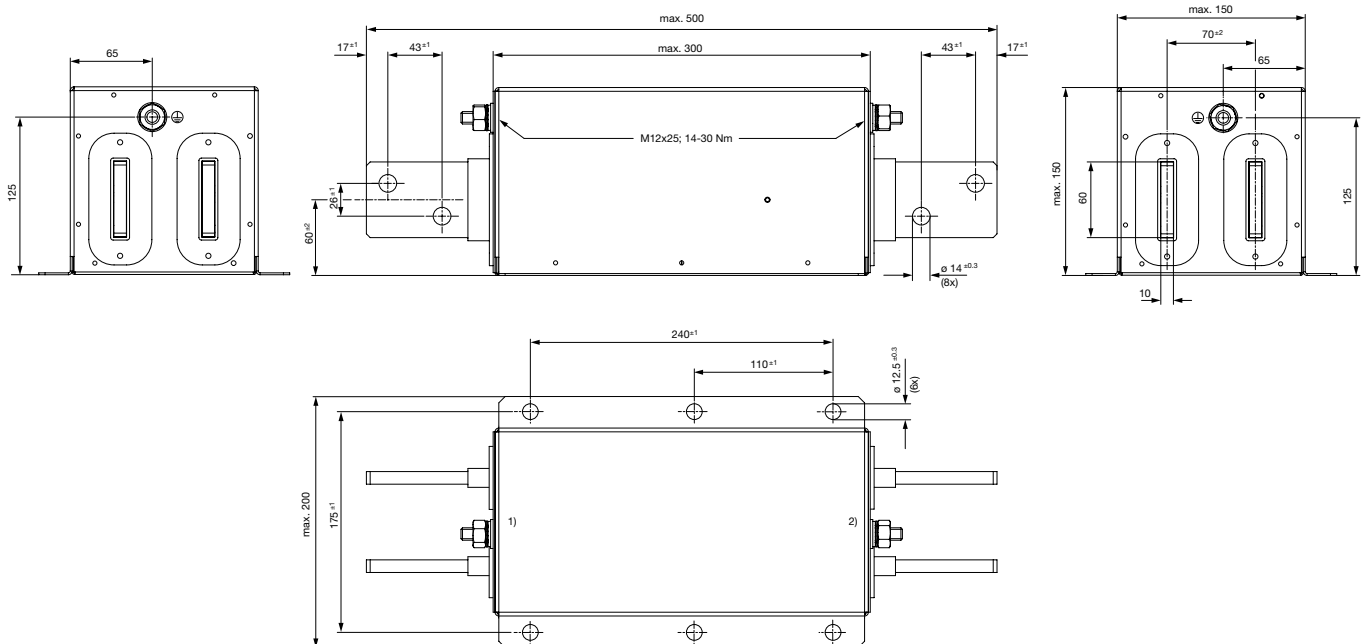

- 1) PV module
- 2) Inverter

Case 2Z

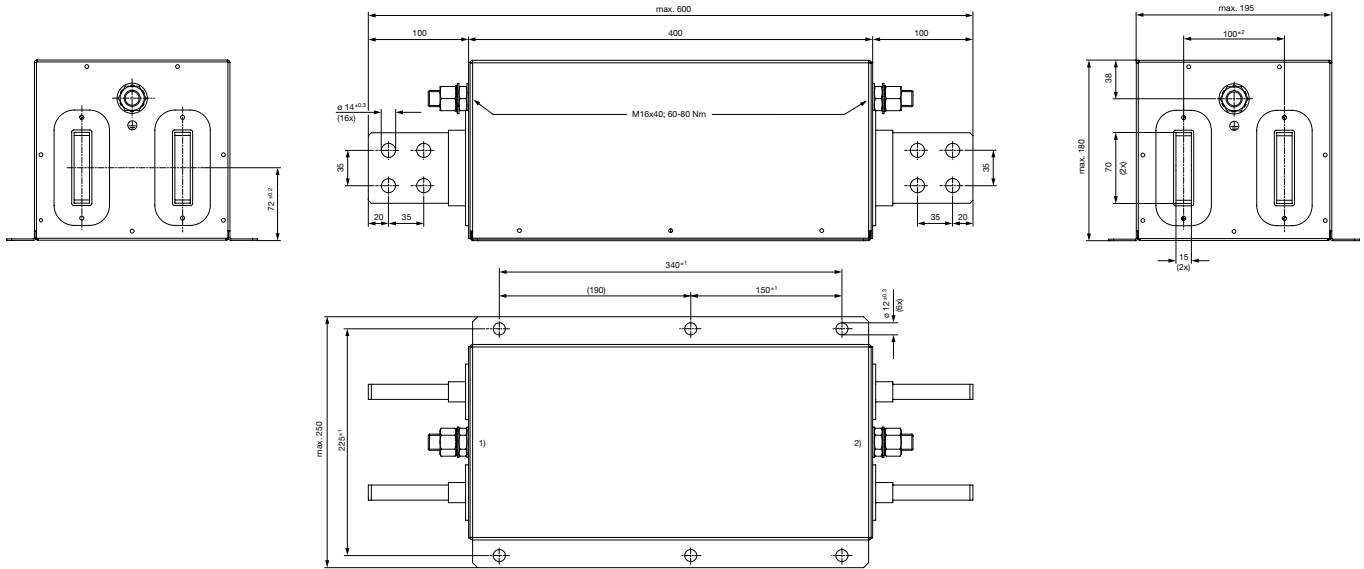

- 1) PV module
- 2) Inverter

Diagrams

Standard version (FMER-G92x-xxxx)

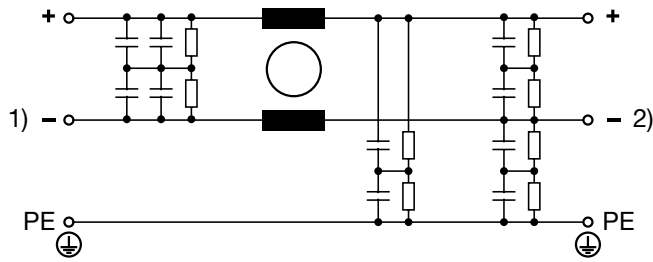

- 1) Photovoltaic module
- 2) Frequency inverter

Version with low leakage current (FMER-G62x-xxxx)

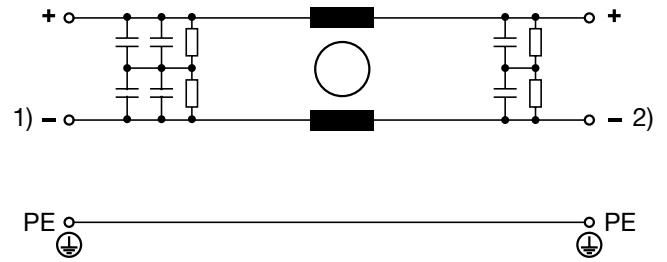

- 1) Photovoltaic module
- 2) Frequency inverter

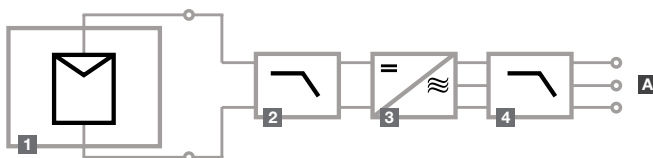

- 1) Photovoltaic module
- 2) DC filter
- 3) Frequency inverter
- 4) AC filter
- A) Power grid

Derating Curves

Permissible Working Current as a Function of Ambient Temperature

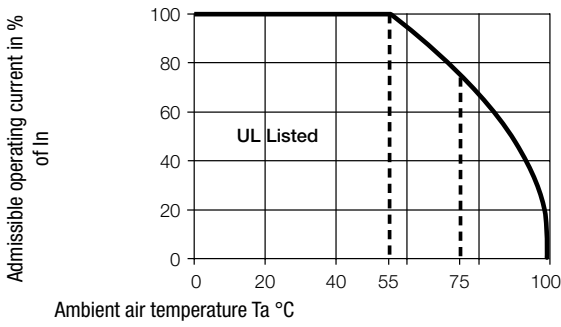

Attenuation Loss 0.1/100Ω differential mode 100/0.1Ω differential mode - - - 50Ω differential mode ____ 50Ω common mode
 Standard version

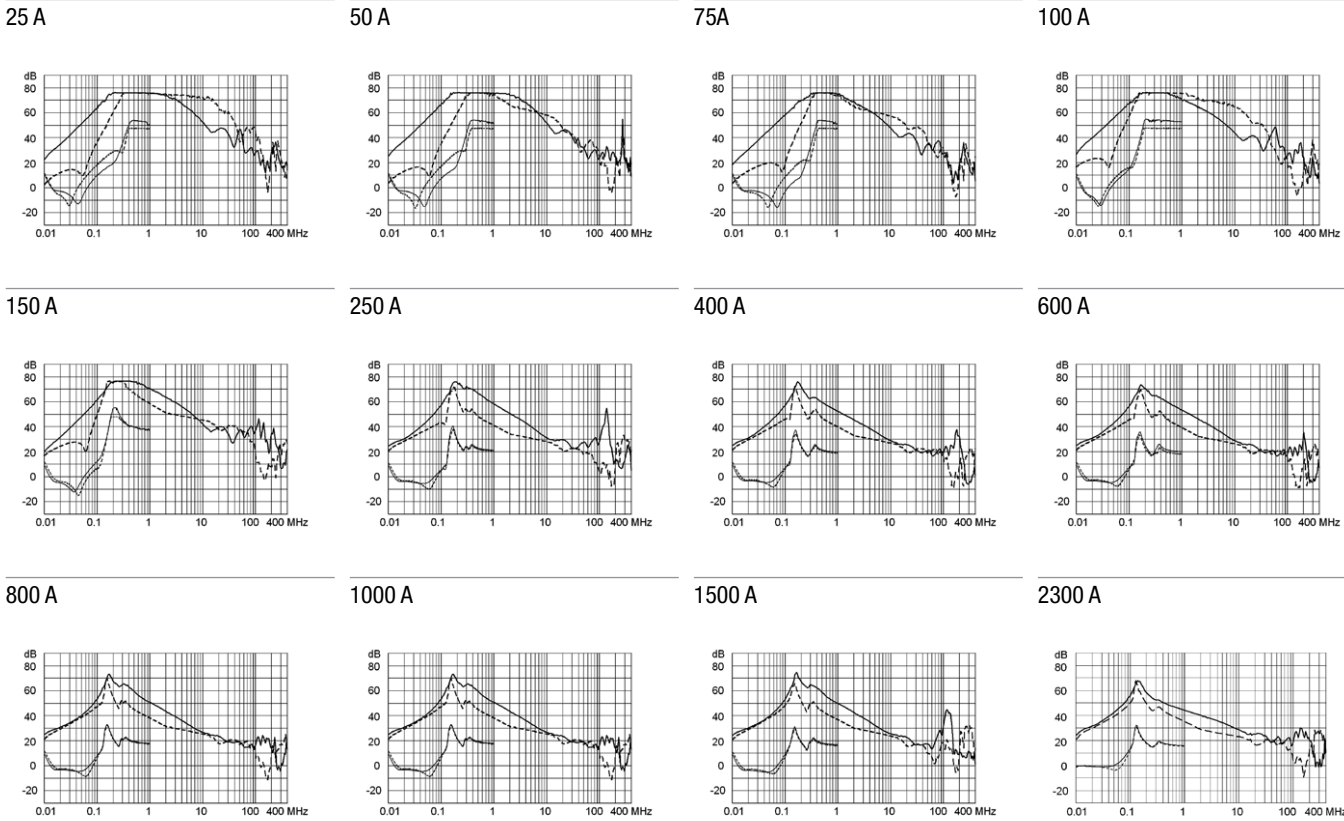

Low leakage current version

25 A

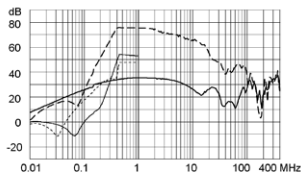

50 A

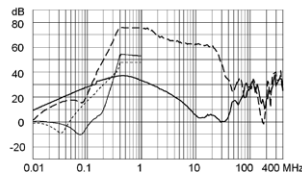

75A

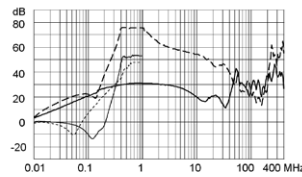

100 A

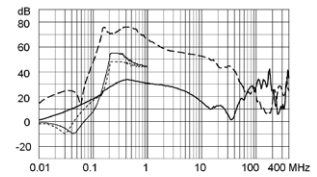

150 A

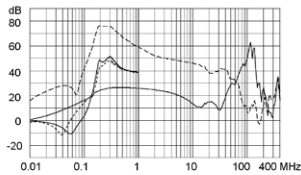

250 A

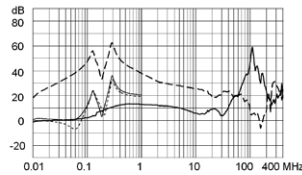

400 A

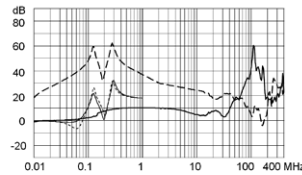

600 A

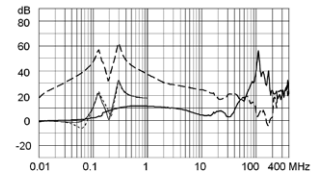

800 A

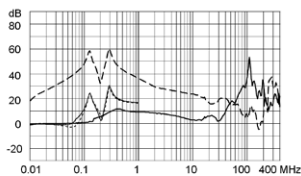

1000 A

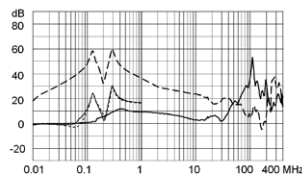

1500 A

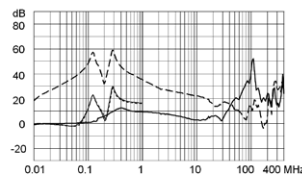

2300 A

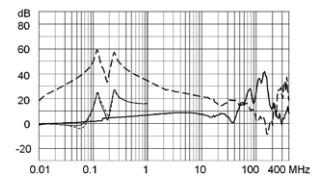

All Variants

Rated Current @ Tu 55°C (75°C) [A]	Rated Voltage [VDC]	cURus approval [VDC]	Tripped Power Dissipation [W]	Weight [kg]	Housing	Order Number
25 (19)	1200	600	4,1	1 kg	2P	FMER-G62P-2517
50 (33)	1200	600	11,5	2 kg	2Q	FMER-G62Q-5017
75 (47)	1200	600	11,3	2 kg	2Q	FMER-G62Q-7517
100 (64)	1200	600	12,6	3 kg	2R	FMER-G62R-J017
150 (100)	1200	600	17,6	5 kg	2S	FMER-G62S-J517
250 (186)	1200	1000	7,8	6 kg	2T	FMER-G62T-K557
400 (280)	1200	1000	13,3	7 kg	2U1	FMER-G62U-M057
600 (380)	1200	1000	22,4	8 kg	2U2	FMER-G62U-U057
800 (600)	1200	1000	24,8	10 kg	2V	FMER-G62V-Q057
1000 (600)	1200	1000	38,8	10 kg	2V	FMER-G62V-S057
1500 (1060)	1200	1000	45,0	24 kg	2W	FMER-G62W-S557
2300 (1200)	1200	1000	80,5	24 kg	2Z	FMER-G62Z-T357
25 (19)	1200	600	4,1	1 kg	2P	FMER-G92P-2517
50 (33)	1200	600	11,5	2 kg	2Q	FMER-G92Q-5017
75 (47)	1200	600	11,3	2 kg	2Q	FMER-G92Q-7517
100 (64)	1200	600	12,6	3 kg	2R	FMER-G92R-J017
150 (100)	1200	600	17,6	5 kg	2S	FMER-G92S-J517
250 (186)	1200	1000	7,8	6 kg	2T	FMER-G92T-K557
400 (280)	1200	1000	13,3	7 kg	2U1	FMER-G92U-M057
600 (380)	1200	1000	22,4	8 kg	2U2	FMER-G92U-U057
800 (600)	1200	1000	24,8	10 kg	2V	FMER-G92V-Q057
1000 (600)	1200	1000	38,8	10 kg	2V	FMER-G92V-S057
1500 (1060)	1200	1000	45,0	24 kg	2W	FMER-G92W-S557
2300 (1200)	1200	1000	80,5	24 kg	2Z	FMER-G92Z-T357

Most Popular.



Rated Current @ Tu 55°C (75°C) [A]	Rated Voltage [VDC]	cURus approval [VDC]	Tripped Power Dissipation [W]	Weight [kg]	Housing	Order Number
---------------------------------------	------------------------	-------------------------	----------------------------------	----------------	---------	--------------

Availability for all products can be searched real-time: <https://www.schurter.com/en/info-center/support-tools/stock-check-distributors>

FMER-G62x-xxxx: low leakage current version without capacitor to ground

Looking for pricing, stock, or lifecycle information?

Click below to explore more details on WIN SOURCE:

-  [View FMER-G62R-J017 on WIN SOURCE](#)
-  [Schurter Inc. Information](#)

Optimize Your Supply Chain with WIN SOURCE Solutions

-  Global Sourcing Solution
-  Obsolete Management
-  Cost Control Management
-  Shortage Management
-  Alternative Solution
-  Excess Inventory Management