

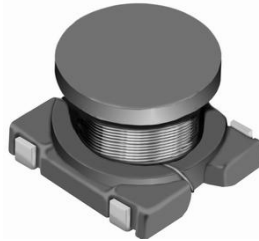

**THE DATASHEET OF
CR32NP-391KC**



SMD Power Inductor CR32



Description

- Ferrite drum core construction.
- Magnetically unshielded.
- L × W × H: 4.1 × 3.8 × 3.0 mm Max.
- Product weight: 85mg(Ref.)
- Moisture Sensitivity Level: 1
- RoHS compliance.

Environmental Data

- Operating temperature range: -40°C ~ +100°C (including coil's self temperature rise)
- Storage temperature range: -40°C ~ +100°C
- Solder reflow temperature: 260 °C peak.

Packaging

- Carrier tape and reel packaging
- 12" diameter reel
- 2000pcs per reel

Applications

- Ideally used in A/V equipment, LCD TV, DSC/DVC, Game Machine, DVC, HDD, Notebook PC, etc as DC-DC converter inductors.

Dimension - [mm]

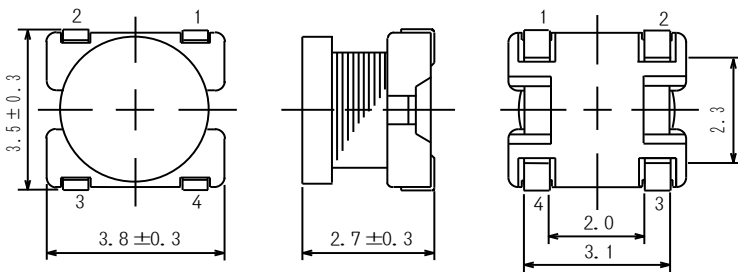

Land pattern and Schematics - [mm]

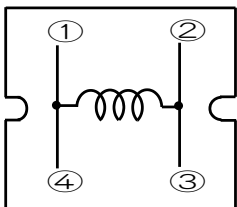
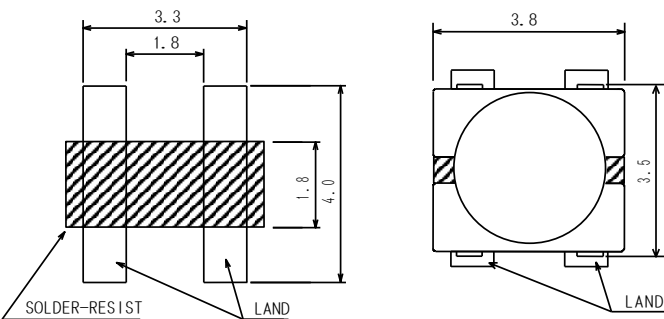



Electrical Characteristics

| Part Name | Stamp | Inductance (μH) [within] $\times 1$ | D.C.R. (m Ω) [Max.] at 20°C | Rated Current (mA) $\times 2$ |
|--------------|----------|--|---|----------------------------------|
| CR32NP-1R0MC | <u>A</u> | 1.0 \pm 20% | 72 | 2100 |
| CR32NP-1R2MC | <u>B</u> | 1.2 \pm 20% | 78 | 1700 |
| CR32NP-1R5MC | <u>C</u> | 1.5 \pm 20% | 85 | 1500 |
| CR32NP-1R8MC | <u>D</u> | 1.8 \pm 20% | 91 | 1320 |
| CR32NP-2R2MC | <u>E</u> | 2.2 \pm 20% | 104 | 1280 |
| CR32NP-2R7MC | <u>F</u> | 2.7 \pm 20% | 111 | 1240 |
| CR32NP-3R3MC | <u>G</u> | 3.3 \pm 20% | 137 | 1180 |
| CR32NP-3R9MC | <u>H</u> | 3.9 \pm 20% | 143 | 1150 |
| CR32NP-4R7MC | <u>J</u> | 4.7 \pm 20% | 170 | 1040 |
| CR32NP-5R6MC | <u>K</u> | 5.6 \pm 20% | 176 | 1000 |
| CR32NP-6R8MC | <u>L</u> | 6.8 \pm 20% | 202 | 880 |
| CR32NP-7R4MC | <u>M</u> | 7.4 \pm 20% | 215 | 840 |
| CR32NP-8R2MC | <u>N</u> | 8.2 \pm 20% | 228 | 780 |
| CR32NP-100KC | A | 10 \pm 10% | 230 | 760 |
| CR32NP-120KC | B | 12 \pm 10% | 270 | 685 |
| CR32NP-150KC | C | 15 \pm 10% | 310 | 635 |
| CR32NP-180KC | D | 18 \pm 10% | 410 | 525 |
| CR32NP-220KC | E | 22 \pm 10% | 470 | 500 |
| CR32NP-270KC | F | 27 \pm 10% | 660 | 405 |
| CR32NP-330KC | G | 33 \pm 10% | 760 | 380 |
| CR32NP-390KC | H | 39 \pm 10% | 850 | 355 |
| CR32NP-470KC | J | 47 \pm 10% | 970 | 330 |
| CR32NP-560KC | K | 56 \pm 10% | 1250 | 290 |
| CR32NP-680KC | L | 68 \pm 10% | 1450 | 275 |
| CR32NP-820KC | M | 82 \pm 10% | 1850 | 235 |
| CR32NP-101KC | N | 100 \pm 10% | 2200 | 220 |
| CR32NP-121KC | P | 120 \pm 10% | 2900 | 185 |
| CR32NP-151KC | Q | 150 \pm 10% | 3400 | 170 |
| CR32NP-181KC | R | 180 \pm 10% | 3900 | 165 |
| CR32NP-221KC | S | 220 \pm 10% | 4500 | 155 |
| CR32NP-271KC | T | 270 \pm 10% | 6000 | 135 |
| CR32NP-331KC | U | 330 \pm 10% | 7000 | 125 |
| CR32NP-391KC | V | 390 \pm 10% | 7800 | 115 |

※1. Inductance measuring frequency: 1.0 μH ~ 8.2 μH ; at 7.96 MHz
10 μH ~ 390 μH ; at 100 kHz

※2. Rated current: The D.C. current at which the inductance decreases to 90% of its initial value or when $\Delta t=40^\circ\text{C}$, whichever is lower ($T_a=20^\circ\text{C}$).

SMD Power Inductor CR32



Saturation Current & Temperature Rise Graph

— L (20°C) — L (100°C) — ΔT

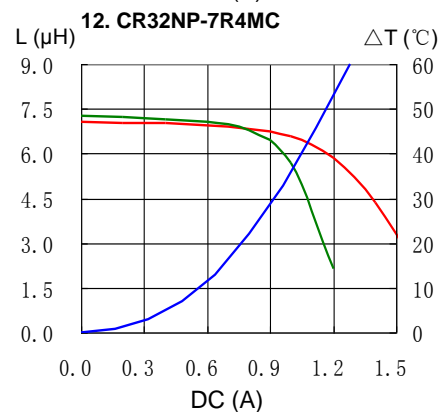
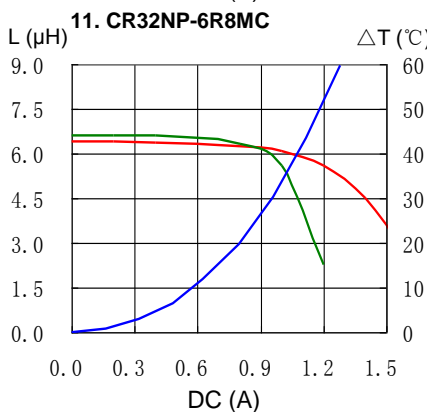
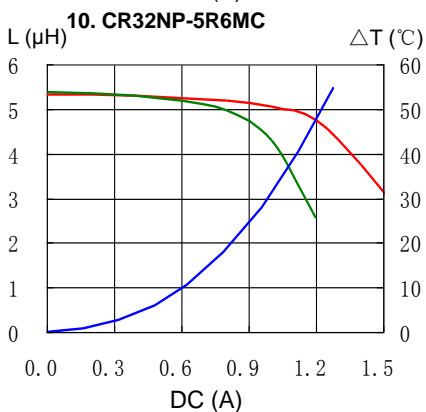
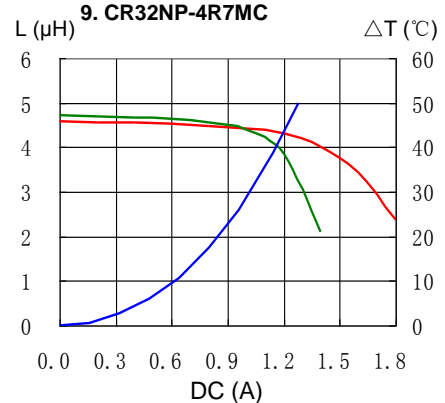
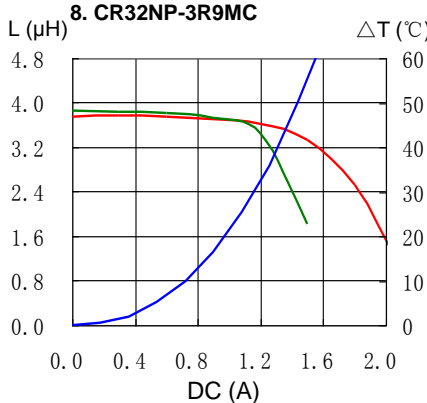
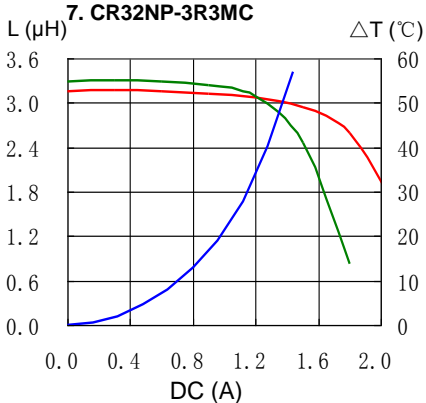
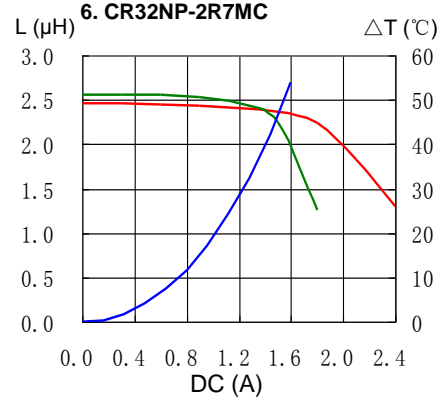
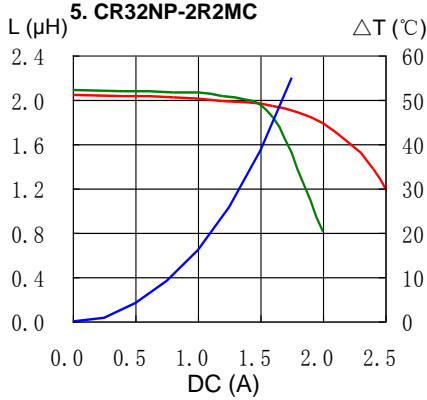
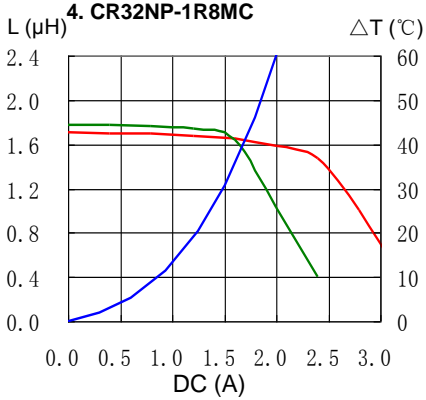
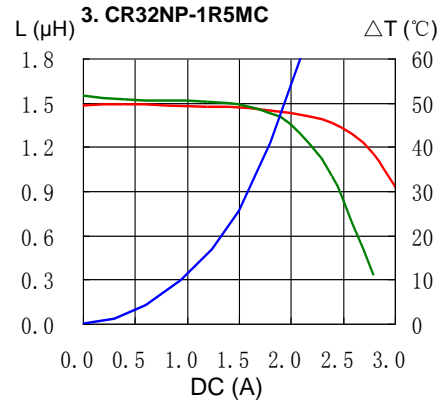
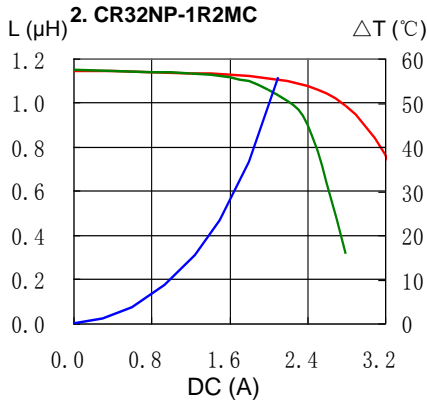
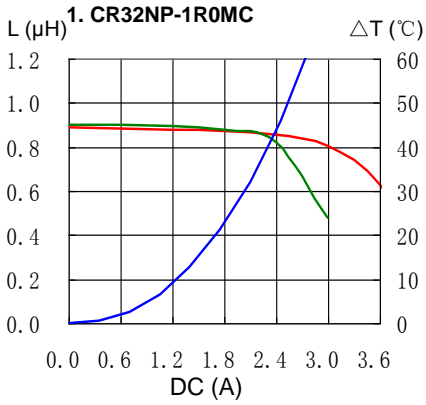

SMD Power Inductor CR32



Saturation Current & Temperature Rise Graph

— L (20°C) — L (100°C) — ΔT

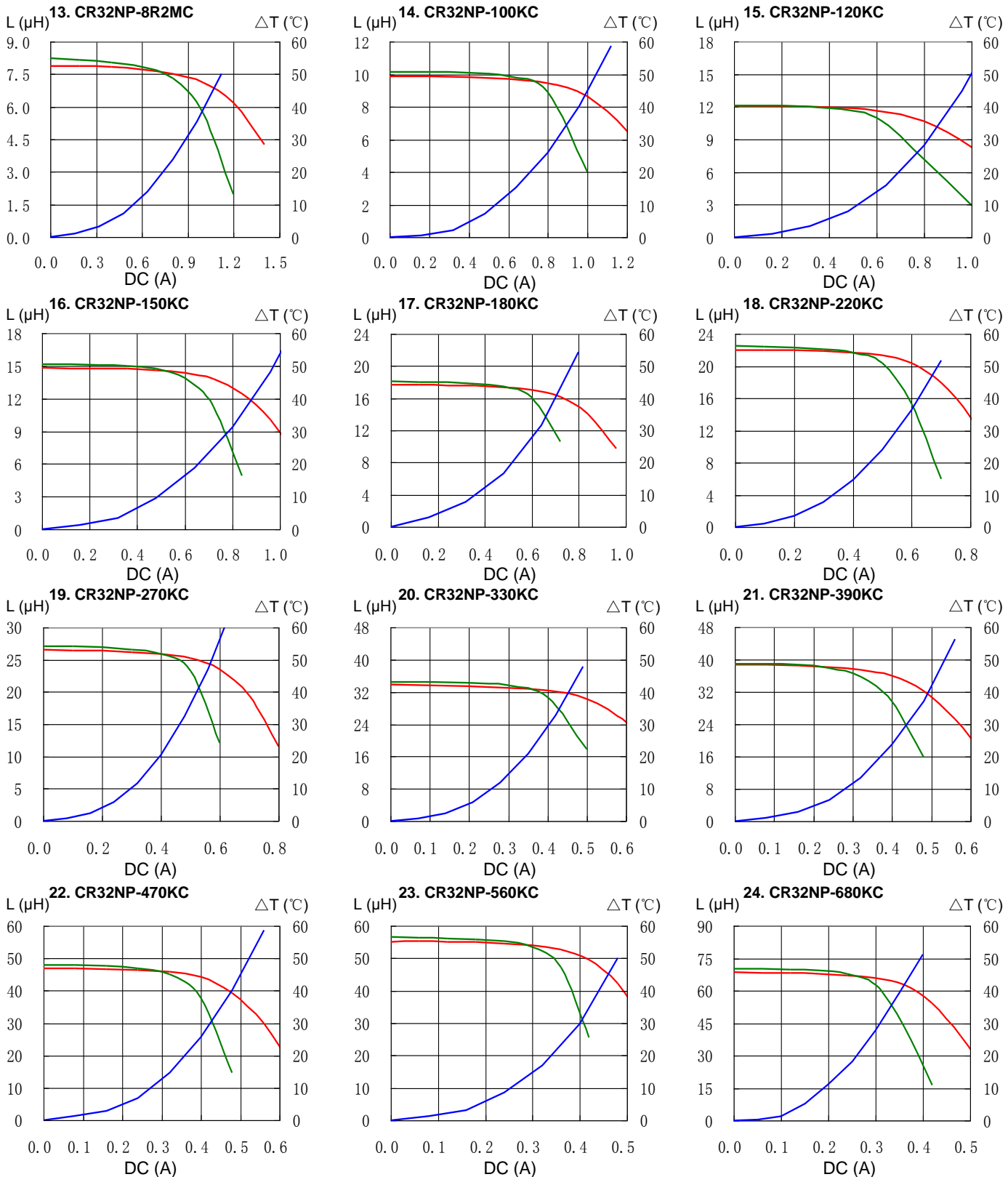

SMD Power Inductor CR32



Saturation Current & Temperature Rise Graph

— L (20°C) — L (100°C) — ΔT

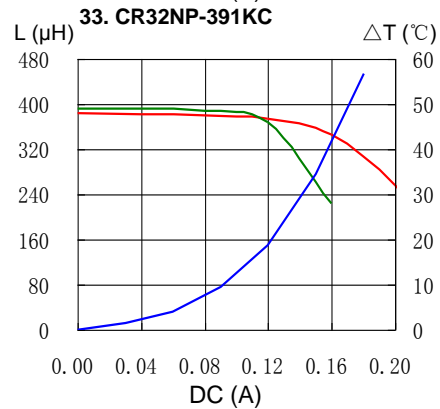
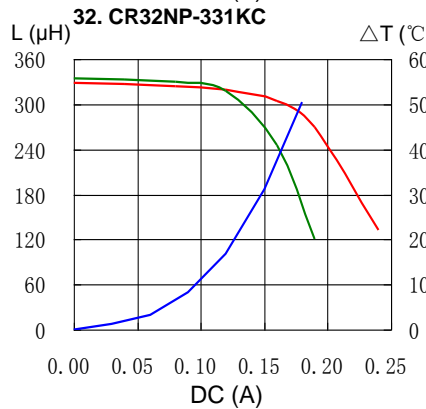
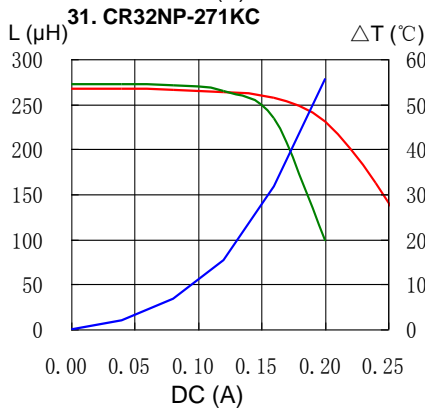
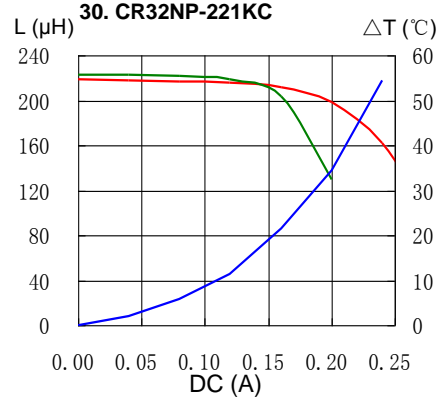
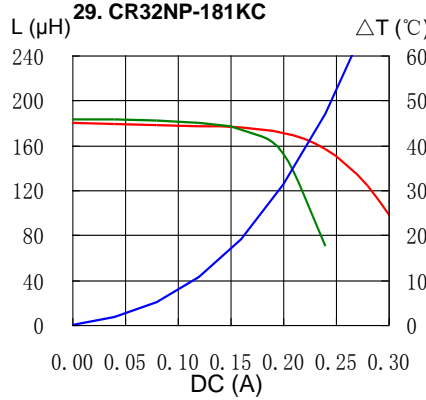
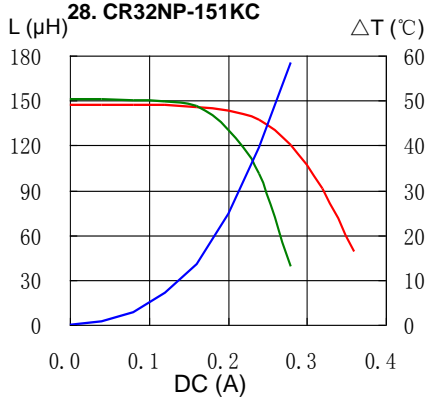
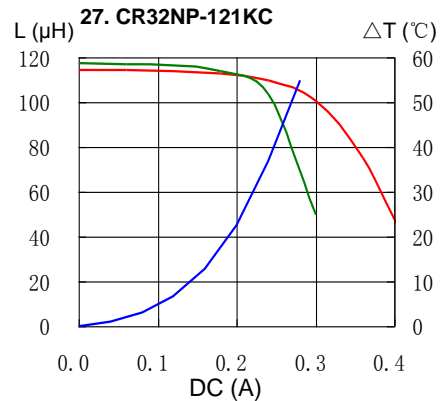
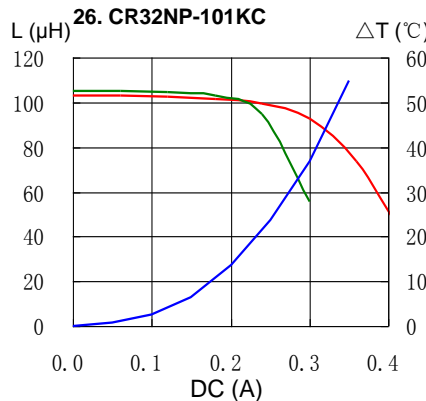
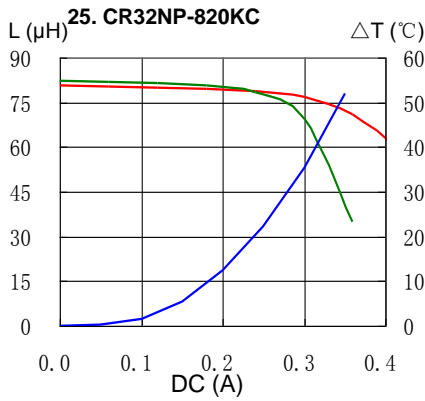

SMD Power Inductor CR32

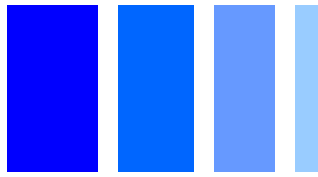

Solder Reflow Condition

Heat Endurance

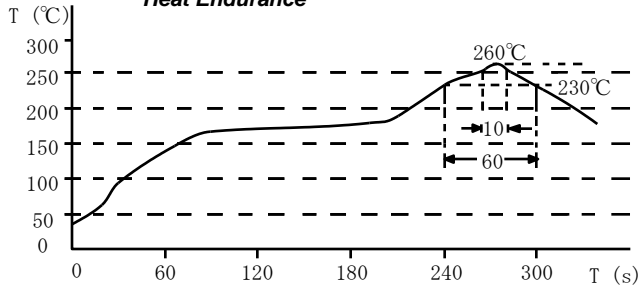

Temperature Chart

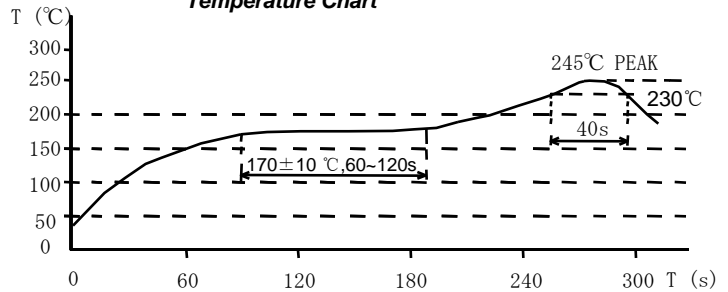

Please refer to the sales offices on our website - <http://www.sumida.com>

Hong Kong

Tel.+852-2880-6781
FAX.+852-2565-9600
sales@hk.sumida.com

Saitama(Japan)

Tel.+81-48-691-7300
FAX.+81-48-691-7340
sales@jp.sumida.com

Chicago

Tel.+1-847-545-6700
FAX. +1-847-545-6720
sales@us.sumida.com

Shanghai

Tel.+86-21-5836-3299
FAX.+86-21-5836-3266
shanghai.sales@cn.sumida.com

Seoul

Tel.+82-2-6237-0777
FAX.+82-2-6237-0778
sales@kr.sumida.com

Obernzell

Tel.+49-8591-937-0
FAX. +49-8591-937-103
contact@eu.sumida.com

Shenzhen

Tel.+86-755-8291-0228
FAX.+86-755-8291-0338
shenzhen.sales@cn.sumida.com

Singapore

Tel.+65-6296-3388
FAX.+65-6841-4426
sales@sg.sumida.com

Neumarkt

Tel.+49-9181-4509-110
FAX. +49-9181-4509-310
infocomp@eu.sumida.com

Taipei

Tel.+886-2-8751-2737
FAX.+886-2-8751-2738
sales@tw.sumida.com

San Jose

Tel.+1-408-321-9660
FAX.+1-408-321-9308
sales@us.sumida.com

Looking for pricing, stock, or lifecycle information?

Click below to explore more details on WIN SOURCE:

- ⊖ [View CR32NP-391KC on WIN SOURCE](#)
- ⊖ [Sumida America Components Inc. Information](#)

Optimize Your Supply Chain with WIN SOURCE Solutions

- ✓ Global Sourcing Solution
- ✓ Obsolete Management
- ✓ Cost Control Management
- ✓ Shortage Management
- ✓ Alternative Solution
- ✓ Excess Inventory Management