

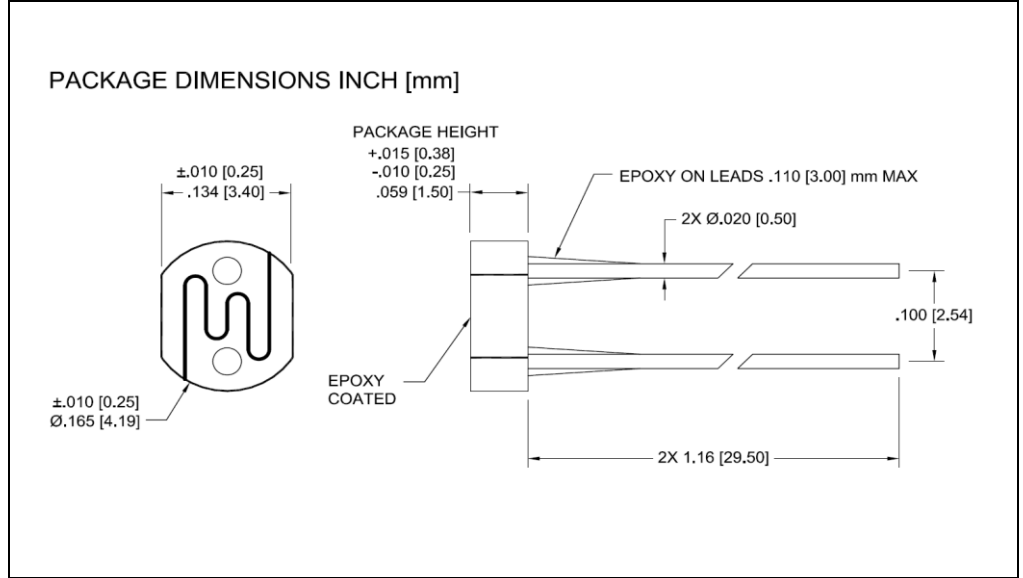

**THE DATASHEET OF
PDV-P9002**





DESCRIPTION

The **PDV-P9002** are (CdS), Photoconductive photocells designed to sense light from 400 to 700 nm. These light dependent resistors are available in a wide range of resistance values. They're packaged in a two leaded plastic-coated ceramic header.

FEATURES

- Visible light response
- Sintered construction
- Low cost

RELIABILITY

This Luna high-reliability device is in principle able to meet military test requirements (Mil-STD-750, Mil-STD-883) after proper screening and group test. Contact Luna for recommendations on specific test conditions and procedures.

APPLICATIONS

- Camera exposure
- Shutter controls
- Night light controls

ABSOLUTE MAXIMUM RATINGS

SYMBOL	MIN		MAX	UNITS	(TA)= 23°C UNLESS OTHERWISE NOTED
Applied Voltage	-	-	150	V	-
Continuous Power Dissipation	-	-	90	mW/°C	-
Operation and Storage Temperature	-30	to	+75	V	-
Soldering Temperature*	-	-	+260	°C	-

* 0.200 inch from base for 3 seconds with heat sink.

OPTO-ELECTRICAL PARAMETERS

T_a = 23°C UNLESS NOTED OTHERWISE

PARAMETER	TEST CONDITIONS	MIN	TYP	MAX	UNITS
Dark Resistance	After 10 sec. @10 Lux @ 2856°K	0.5	-	-	MΩ
Illuminated Resistance	10 Lux @ 2856°K	9	-	20	KΩ
Sensitivity	$\frac{\text{Log}(R100) - \text{Log}(R10)}{\text{Log}(E100) - \text{Log}(E10)}$	-	0.6	-	Ω/Lux
Spectral Application Range	Flooded	400	-	700	nm
Spectral Application Range	Flooded	-	570	-	nm
Rise Time	10 Lux @ 2856 °K	-	60	-	ms
Fall Time	After 10 Lux @ 2856 °K	-	25	-	ms

**R100, R10: cell resistances at 100 Lux and 10 Lux at 2856 °K respectively .

***E100, E10: luminances at 100 Lux and 10 Lux 2856 °K respectively.

Looking for pricing, stock, or lifecycle information?

Click below to explore more details on WIN SOURCE:

 [View PDV-P9002 on WIN SOURCE](#)

 [Advanced Photonix, Inc. Information](#)

Optimize Your Supply Chain with WIN SOURCE Solutions

-  Global Sourcing Solution
-  Obsolete Management
-  Cost Control Management
-  Shortage Management
-  Alternative Solution
-  Excess Inventory Management