



**THE DATASHEET OF
CS3341YDR14**



CS3341, CS3351, CS387

Alternator Voltage Regulator Darlington Driver

The CS3341/3351/387 integral alternator regulator integrated circuit provides the voltage regulation for automotive, 3-phase alternators.

It drives an external power Darlington for control of the alternator field current. In the event of a charge fault, a lamp output pin is provided to drive an external darlington transistor capable of switching on a fault indicator lamp. An overvoltage or no STATOR signal condition activates the lamp output.

The CS3341 and CS3351 are available in SOIC-14 packages. The CS387 is available as a Flip Chip.

For FET driver applications use the CS3361. Use of the CS3341, CS3351 or CS387 with external FETs may result in oscillations.

Features

- Drives NPN Darlington
- Short Circuit Protection
- 80 V Load Dump
- Temperature Compensated Regulation Voltage
- Shorted Field Protection Duty Cycle, Self Clearing
- Pb-Free Packages are Available*

MAXIMUM RATINGS

Rating	Value	Unit
Storage Temperature Range, T_S	-55 to +165	°C
Junction Temperature Range	-40 to 150	°C
Continuous Supply	27	V
I_{CC} Load Dump	400	mA
Lead Temperature Soldering: Reflow: (SMD styles only) (Note 1)	230 peak	°C

Maximum ratings are those values beyond which device damage can occur. Maximum ratings applied to the device are individual stress limit values (not normal operating conditions) and are not valid simultaneously. If these limits are exceeded, device functional operation is not implied, damage may occur and reliability may be affected.

1. 60 second maximum above 183°C.



ON Semiconductor®

<http://onsemi.com>

MARKING DIAGRAM

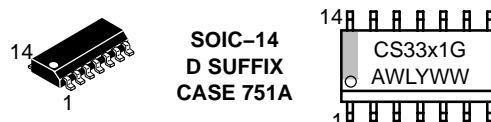

CS33x1 = Specific Device Code
 x = 4 or 5
 A = Assembly Location
 WL = Wafer Lot
 Y = Year
 WW = Work Week
 G = Pb-Free Package

PIN CONNECTIONS

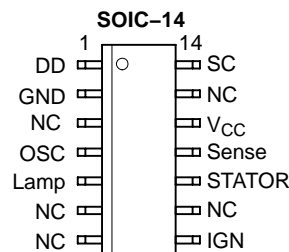

Flip Chip, Bump Side Up

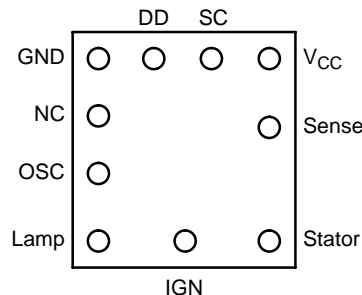

ORDERING INFORMATION

See detailed ordering and shipping information in the package dimensions section on page 4 of this data sheet.

*For additional information on our Pb-Free strategy and soldering details, please download the ON Semiconductor Soldering and Mounting Techniques Reference Manual, SOLDERRM/D.

CS3341, CS3351, CS387

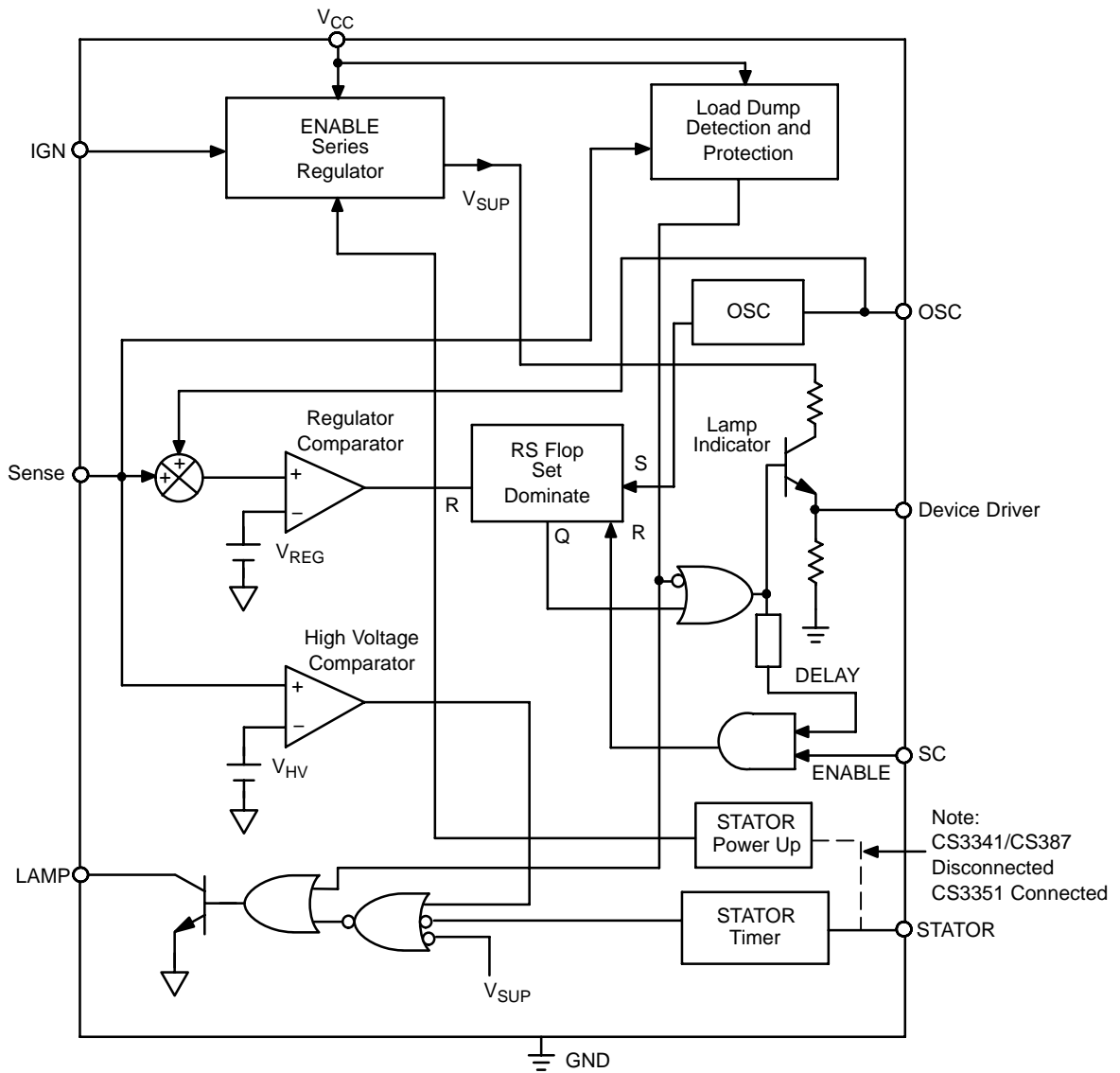

Figure 1. Block Diagram

CS3341, CS3351, CS387

ELECTRICAL CHARACTERISTICS ($-40^{\circ}\text{C} < T_A < 125^{\circ}\text{C}$, $-40^{\circ}\text{C} < T_J < 150^{\circ}\text{C}$, $9.0\text{ V} \leq V_{CC} \leq 17\text{ V}$; unless otherwise specified.)

Characteristic	Test Conditions	Min	Typ	Max	Unit
----------------	-----------------	-----	-----	-----	------

Supply

Supply Current Enabled	–	–	12	25	mA
Supply Current Disabled	–	–	–	50	μA

Driver Stage

Output High Current	$V_{DD} = 1.2\text{ V}$	–10	–6.0	–4.0	mA
Output Low Voltage	$I_{OL} = 25\ \mu\text{A}$	–	–	0.35	V
Minimum ON Time	–	200	–	–	μs
Minimum Duty Cycle	–	–	6.0	10	%
Short Circuit Duty Cycle	–	1.0	–	5.0	%
Field Switch Turn On Rise Time	–	30	–	90	μs
Field Switch Turn On Fall Time	–	30	–	90	μs

Stator

Input High Voltage	–	10	–	–	V
Input Low Voltage	–	–	–	6.0	V
Stator Time Out	High to Low	6.0	100	600	ms
Stator Power-Up Input High	CS3351 only	10	–	–	V
Stator Power-Up Input Low	CS3351 only	–	–	6.0	V

Lamp

Output High Current	$V_{LAMP} @ 3.0\text{ V}$	–	–	50	μA
Output Low Voltage	$I_{LAMP} @ 30\text{ mA}$	–	–	0.35	V

Ignition

Input High Voltage	$I_{CC} > 1.0\text{ mA}$	1.8	–	–	V
Input Low Voltage	$I_{CC} < 100\ \mu\text{A}$	–	–	0.5	V

Oscillator

Oscillator Frequency	$C_{OSC} = 0.22\ \mu\text{F}$	65	–	325	Hz
Rise Time/Fall Time	$C_{OSC} = 0.22\ \mu\text{F}$	–	17	–	–
Oscillator High Threshold	$C_{OSC} = 0.22\ \mu\text{F}$	–	–	6.0	V

Battery Sense

Input Current	–	–10	–	+10	μA
Regulation Voltage	@25°C, $R_1 = 100\text{ k}\Omega$, $R_2 = 50\text{ k}\Omega$	13.5	–	16	V
Proportional Control	–	0.050	–	0.400	V
High Voltage Threshold Ratio	$\frac{V_{\text{High Voltage @ Lamp On}}}{V_{\text{Regulation @ 50\% Duty Cycle}}}$	1.083	–	1.190	–
High Voltage Hysteresis	–	0.020	–	0.600	V

CS3341, CS3351, CS387

PACKAGE PIN DESCRIPTION

PACKAGE PIN #		PIN SYMBOL	FUNCTION
SOIC-14	Flip Chip		
1	1	Driver	Output driver for external power switch-Darlington
2	2	GND	Ground
3, 6, 7, 9, 13	3	NC	No Connection
4	4	OSC	Timing capacitor for oscillator
5	5	Lamp	Base driver for lamp driver indicates no stator signal or overvoltage condition
8	6	IGN	Switched ignition powerup
10	7	Stator	Stator signal input for stator timer (CS3351 also powerup)
11	8	Sense	Battery sense voltage regulator comparator input and protection
12	9	V _{CC}	Supply for IC
14	10	SC	Short circuit sensing

ORDERING INFORMATION

Device	Package	Shipping [†]
CS3341YD14	SOIC-14	55 Units/Rail
CS3341YD14G	SOIC-14 (Pb-Free)	55 Units/Rail
CS3341YDR14	SOIC-14	2500 Tape & Reel
CS3341YDR14G	SOIC-14 (Pb-Free)	2500 Tape & Reel
CS3351YD14	SOIC-14	55 Units/Rail
CS3351YD14G	SOIC-14 (Pb-Free)	55 Units/Rail
CS3351YDR14	SOIC-14	2500 Tape & Reel
CS3351YDR14G	SOIC-14 (Pb-Free)	2500 Tape & Reel
CS387H	Flip Chip	Contact Sales

[†]For information on tape and reel specifications, including part orientation and tape sizes, please refer to our Tape and Reel Packaging Specifications Brochure, BRD8011/D.

TYPICAL PERFORMANCE CHARACTERISTICS

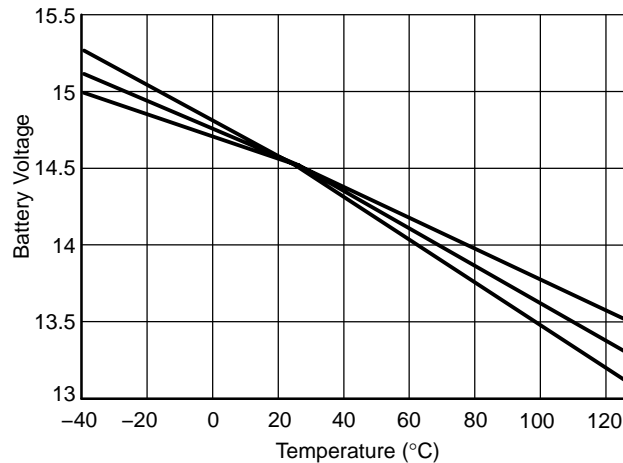

Figure 2. Battery Voltage vs. Temperature (°C) Over Process Variation

APPLICATIONS INFORMATION

The CS3341 and CS3351 IC's are designed for use in an alternator charging system. The circuit is also available in flip-chip form as the CS387.

In a standard alternator design (Figure 3), the rotor carries the field winding. An alternator rotor usually has several N and S poles. The magnetic field for the rotor is produced by forcing current through a field or rotor winding. The Stator windings are formed into a number of coils spaced around a cylindrical core. The number of coils equals the number of pairs of N and S poles on the rotor. The alternating current in the Stator windings is rectified by the diodes and applied to the regulator. By controlling the amount of field current, the magnetic field strength is controlled and hence the output voltage of the alternator.

Referring to Figure 7, a typical application diagram, the oscillator frequency is set by an external capacitor connected between OSC and ground. The sawtooth waveform ramps between 1.0 V and 3.0 V and provides the timing for the system. For the circuit shown the oscillator frequency is approximately 140 Hz. The alternator voltage is sensed at Terminal A via the resistor divider network R1/R2 on the Sense pin of the IC. The voltage at the sense pin determines the duty cycle for the regulator. The voltage is adjusted by potentiometer R2. A relatively low voltage on the sense pin causes a long duty cycle that increases the Field current. A high voltage results in a short duty cycle.

The ignition Terminal (I) switches power to the IC through the V_{CC} pin. In the CS3351 the Stator pin senses the voltage from the stator. This will keep the device powered while the voltage is high, and it also senses a stopped engine condition and drives the Lamp pin high after the stator

timeout expires. The Lamp pin also goes high when an overvoltage condition is detected on the sense pin. This causes the darlington lamp drive transistor to switch on and pull current through the lamp. If the system voltage continues to increase, the field and lamp output turn off as in an overvoltage or load dump condition.

The SC or Short Circuit pin monitors the field voltage. If the drive output and the SC voltage are simultaneously high for a predetermined period, a short circuit condition is assumed and the output is disabled. The regulator is forced to a minimum short circuit duty cycle.

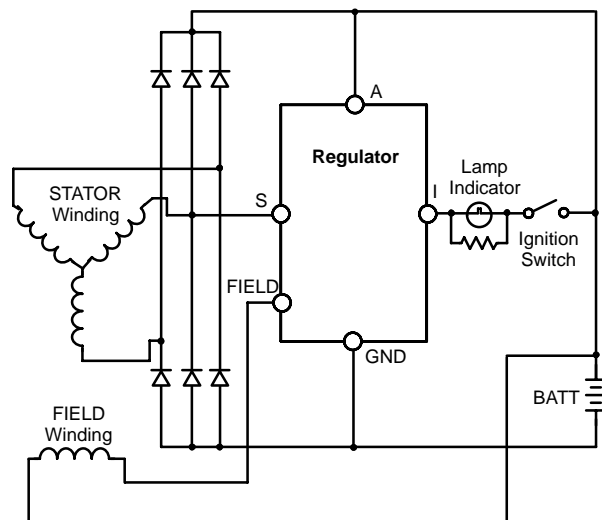

Figure 3. IAR System Block Diagram

REGULATION WAVEFORMS

The CS3341/3351/387 utilizes proportion control to maintain regulation. Waveforms depicting operation are shown in Figures 4, 5 and 6, where $V_{BAT/N}$ is the divided down voltage present on the Sense pin using R1 and R2 (Figure 7). A sawtooth waveform is generated internally. The amplitude of this waveform is listed in the electric parameter section as proportion control. The oscillator voltage is summed with $V_{BAT/N}$, and compared with the internal voltage regulator (V_{REG}) in the regulation

comparator which controls the field through the output "Device Driver."

Figure 4 shows typical steady-state operation. A 50% duty cycle is maintained.

Figure 5 shows the effect of a drop in voltage on ($V_{BAT/N} + V_{OSC}$). Notice the duty cycle increase to the field drive.

Figure 6 shows the effect of an increase in voltage (above the regulation voltage) on ($V_{BAT/N} + V_{OSC}$). Notice the decrease in field drive.

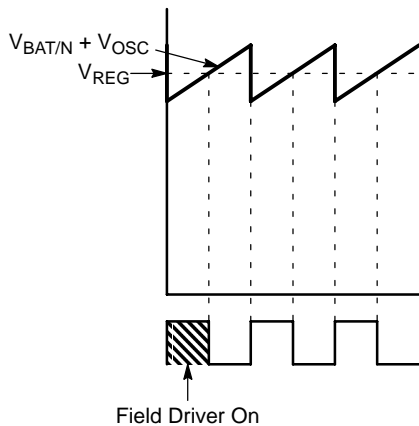

Figure 4. 50% Duty Cycle, Steady State

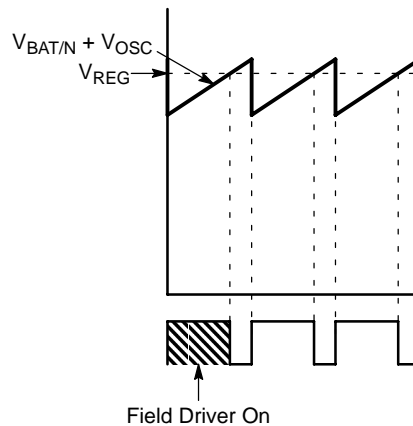

Figure 5. > 50% Duty Cycle, Increased Load

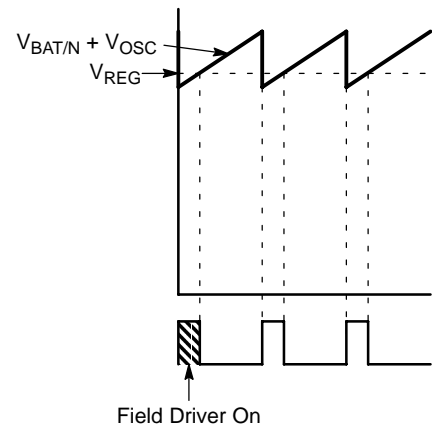

Figure 6. < 50% Duty Cycle, Decreased Load

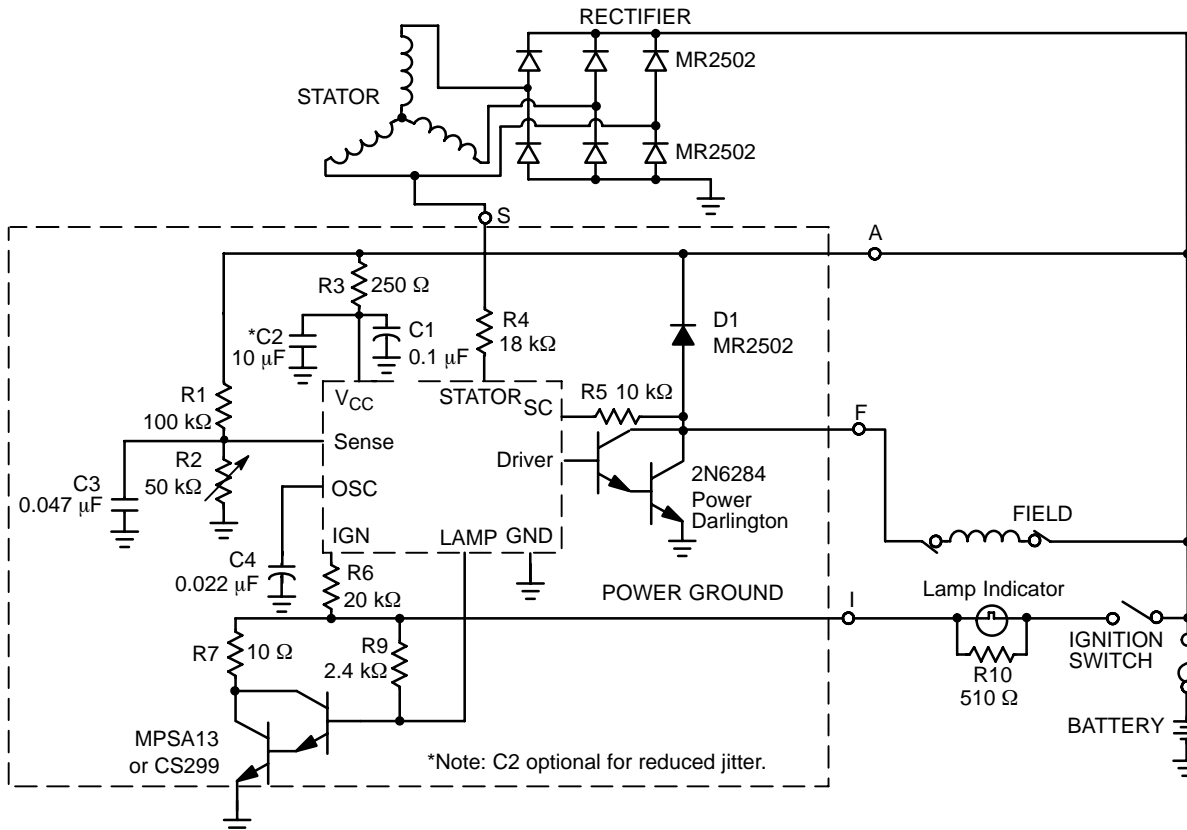

Figure 7. Typical Application Diagram

CS3341, CS3351, CS387

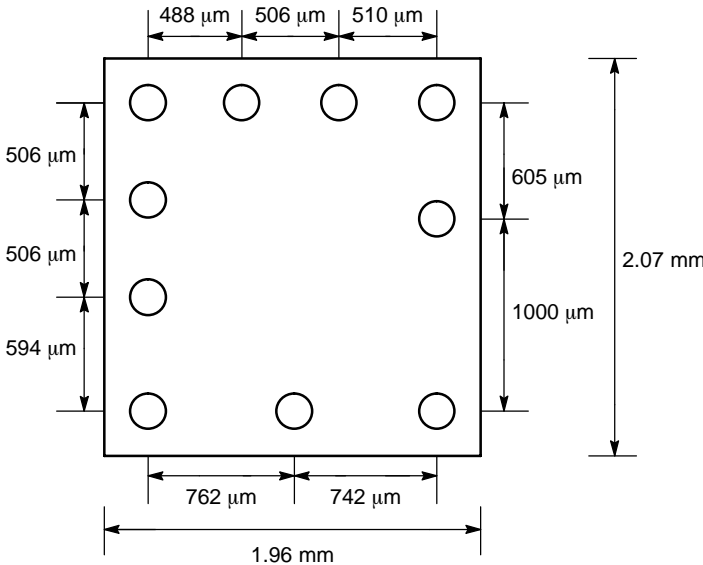
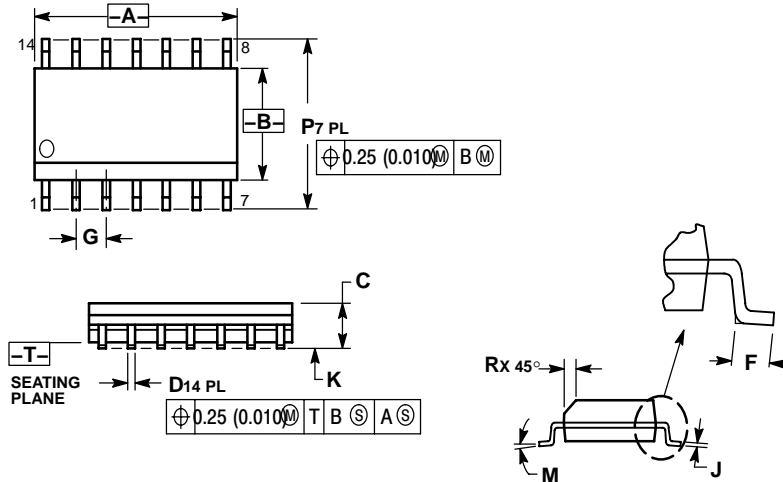

Figure 8. Flip Chip Dimensions and Solder Bump Locations, Bump Side Up

CS3341, CS3351, CS387

PACKAGE DIMENSIONS

SOIC-14 D SUFFIX CASE 751A-03 ISSUE G



- NOTES:
1. DIMENSIONING AND TOLERANCING PER ANSI Y14.5M, 1982.
 2. CONTROLLING DIMENSION: MILLIMETER.
 3. DIMENSIONS A AND B DO NOT INCLUDE MOLD PROTRUSION.
 4. MAXIMUM MOLD PROTRUSION 0.15 (0.006) PER SIDE.
 5. DIMENSION D DOES NOT INCLUDE DAMBAR PROTRUSION. ALLOWABLE DAMBAR PROTRUSION SHALL BE 0.127 (0.005) TOTAL IN EXCESS OF THE D DIMENSION AT MAXIMUM MATERIAL CONDITION.

DIM	MILLIMETERS		INCHES	
	MIN	MAX	MIN	MAX
A	8.55	8.75	0.337	0.344
B	3.80	4.00	0.150	0.157
C	1.35	1.75	0.054	0.068
D	0.35	0.49	0.014	0.019
F	0.40	1.25	0.016	0.049
G	1.27 BSC		0.050 BSC	
J	0.19	0.25	0.008	0.009
K	0.10	0.25	0.004	0.009
M	0°	7°	0°	7°
P	5.80	6.20	0.228	0.244
R	0.25	0.50	0.010	0.019

PACKAGE THERMAL DATA

Parameter		SOIC-14	Unit
R _{θJC}	Typical	30	°C/W
R _{θJA}	Typical	125	°C/W

ON Semiconductor and are registered trademarks of Semiconductor Components Industries, LLC (SCILLC). SCILLC reserves the right to make changes without further notice to any products herein. SCILLC makes no warranty, representation or guarantee regarding the suitability of its products for any particular purpose, nor does SCILLC assume any liability arising out of the application or use of any product or circuit, and specifically disclaims any and all liability, including without limitation special, consequential or incidental damages. "Typical" parameters which may be provided in SCILLC data sheets and/or specifications can and do vary in different applications and actual performance may vary over time. All operating parameters, including "Typicals" must be validated for each customer application by customer's technical experts. SCILLC does not convey any license under its patent rights nor the rights of others. SCILLC products are not designed, intended, or authorized for use as components in systems intended for surgical implant into the body, or other applications intended to support or sustain life, or for any other application in which the failure of the SCILLC product could create a situation where personal injury or death may occur. Should Buyer purchase or use SCILLC products for any such unintended or unauthorized application, Buyer shall indemnify and hold SCILLC and its officers, employees, subsidiaries, affiliates, and distributors harmless against all claims, costs, damages, and expenses, and reasonable attorney fees arising out of, directly or indirectly, any claim of personal injury or death associated with such unintended or unauthorized use, even if such claim alleges that SCILLC was negligent regarding the design or manufacture of the part. SCILLC is an Equal Opportunity/Affirmative Action Employer. This literature is subject to all applicable copyright laws and is not for resale in any manner.

PUBLICATION ORDERING INFORMATION

LITERATURE FULFILLMENT:
Literature Distribution Center for ON Semiconductor
P.O. Box 61312, Phoenix, Arizona 85082-1312 USA
Phone: 480-829-7710 or 800-344-3860 Toll Free USA/Canada
Fax: 480-829-7709 or 800-344-3867 Toll Free USA/Canada
Email: orderlit@onsemi.com

N. American Technical Support: 800-282-9855 Toll Free
USA/Canada

Japan: ON Semiconductor, Japan Customer Focus Center
2-9-1 Kamimeguro, Meguro-ku, Tokyo, Japan 153-0051
Phone: 81-3-5773-3850

ON Semiconductor Website: <http://onsemi.com>

Order Literature: <http://www.onsemi.com/litorder>

For additional information, please contact your local Sales Representative.

Looking for pricing, stock, or lifecycle information?

Click below to explore more details on WIN SOURCE:

 [View CS3341YDR14 on WIN SOURCE](#)

 [ON Semiconductor](#) Information

Optimize Your Supply Chain with WIN SOURCE Solutions

-  Global Sourcing Solution
-  Obsolete Management
-  Cost Control Management
-  Shortage Management
-  Alternative Solution
-  Excess Inventory Management