



**THE DATASHEET OF
DF63-3S-3.96C**



15A 3.96mm pitch Wire-to-Board Connectors for Internal Power Supply

DF63 Series

(UL, C-UL, TÜV, Listed)

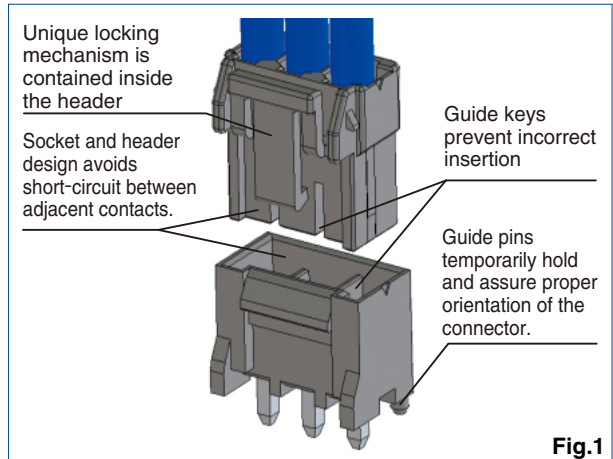
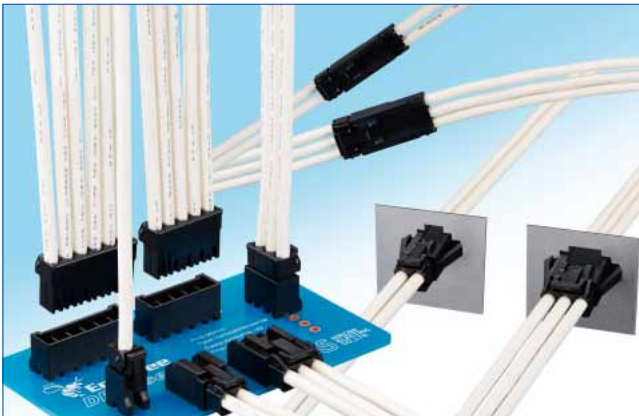

Fig.1

■ Features

1. Rated for up to 15A

DF63 has the capacity to handle a max of 15A when using 16 AWG wire.
(Please refer to the chart for the rated current in other pin counts.)

2. Secure mating and clear tactile click

The locking mechanism delivers a clear and tactile click, which prevents incomplete mating. (Fig.2)

3. Prevents incomplete insertion of the crimp contact

A structure to prevent incomplete insertion of the crimp contacts is provided. (Fig.3)

4. Prevents incorrect mating

A mechanism has been added to prevent reverse mating and incorrect mating between different number of positions. (Fig.4)

5. Reverse mounting prevention to PCB

The pin header is equipped with a guide post to prevent reverse insertion on the PCB. (Fig.1)

6. Molded lance design

The lance is actually part of the housing instead of being a part of the terminal. This prevents tangled wires during assembly.

7. Short-circuit prevention

The wall structure between the contacts helps to isolate the contacts and prevents short circuits between contacts. (Fig.1)

8. Suitable for potting

Capable of being potted, up to 5mm.

9. Solder crack prevention

Glass-reinforced resin is used on the pin header to prevent solder cracks due to thermal contraction.

* Keying options were provided to prevent incorrect connections.

Keying options prevent incorrect connections due to the use of multiple connectors on the same board. When using identical pin counts, two versions are available with different keying options. (Fig.4)

* Supports 7.92mm pitch

Also supports 7.92mm pitch with 2 or 3 pos. without pins

Note 1 : * means the product will be available upon request.
Please contact Hirose representative.

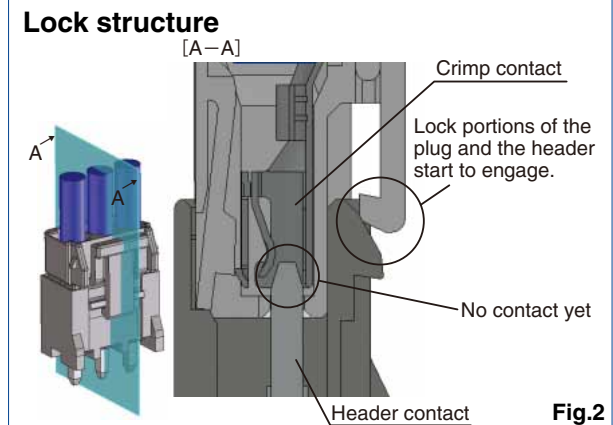

Fig.2

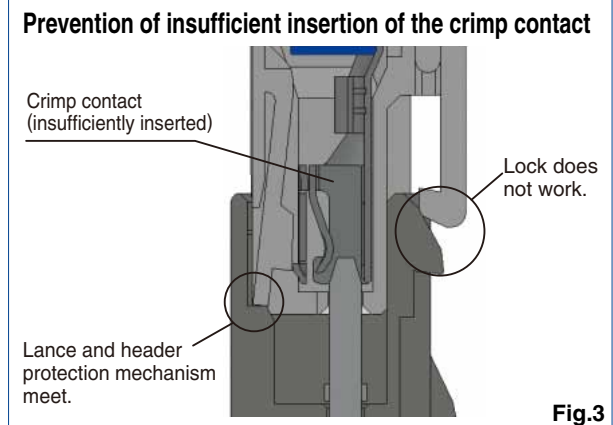

Fig.3

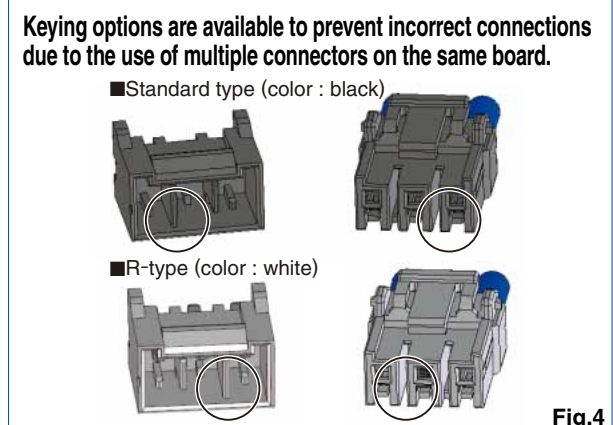

Fig.4

Product Specifications

Ratings	Current Rating	No. of Contacts	16 AWG	18 AWG	20 AWG	22 AWG	Operating temperature range	-55 to 105°C (Note 2)	
		1	15A	13A	11A	9A	Operating humidity range	20 to 80% (Note 3)	
		2	14A	12A	10A	8A	Storage temperature range	-10 to 60°C (Note 4)	
		3	12A	10A	8A	7A	Storage humidity range	40 to 70% (Note 4)	
		4	10A	8A	7A	6A	UL/TÜV File No. and Recognition No. UL : E52653 C-UL : E52653 TÜV : R50318850		
		5	10A	8A	7A	6A			
		6	10A	8A	7A	6A			
		2 (7.92mm pitch)	15A	13A	11A	9A			
	Voltage Rating	Specification	UL,C-UL	AC/DC 630V					
			TÜV	AC/DC 600V					
			AC/DC 300V						

Item	Specifications	Conditions
1. Insulation Resistance	No less than 1,000MΩ	Measured at DC 500V
2. Withstand Voltage	No flashover or breakdown	AC 1,500V is applied for one minute.
3. Contact Resistance	No more than 10mΩ	Measured at 1mA and no higher than 20mV
4. Vibration Resistance	No electrical discontinuity of 1μs or greater	Frequency 10-55 Hz, half amplitude 0.75 mm, 10 times in each of the three directions
5. Shock Resistance	No electrical discontinuity of 1μs or greater	Accelerated velocity : 490 m/s ² for 11ms, half-sine wave in 3 directions, 3 times for each direction
6. Moisture-resistance	Contact resistance : no more than 20mΩ Insulation resistance : no less than 500MΩ	Temperature : 40±2°C ; humidity : 90 to 95%, left as it is for 96 hours
7. Temperature cycles	Contact resistance : no more than 20mΩ Insulation resistance : no less than 1,000MΩ	-55°C : 30 minutes → 85°C : 30 minutes 5 cycles
8. Durability	Contact resistance : no more than 20mΩ	Tin plated : 30 mating cycles, Gold plated : 50 mating cycles
9. Solder heat resistance	The resin parts should withstand the temperature and resist melting.	Flow : 260°C, 10 sec Hand soldering : temperature of soldering iron at 300°C for 3 seconds

Note 1 : This is the maximum current rating while all pins are powered or used as all power lines.

Note 2 : Includes temperature rise caused by current flow.

Note 3 : Use without condensation on parts.

Note 4 : The storage condition refers to long-term storage of the product on the shelf before assembly. Please use the operating temperature for temporary storage such as pre-assembly and during shipping.

Materials / Finish

Component	Part	Material	Finish	UL Specification
Header	Insulator	PBT (glass-reinforced)	Black or White	UL94V-0
	Contact	Brass	Tin plated or Gold plated	—
Crimp socket	Insulator	PBT (glass-reinforced)	Black or White	UL94V-0
In-line plug				
Crimp contact	Contact	Copper alloy	Tin plated or Gold plated	—

Product Number Structure

Connector

DF 63 # - * P - 3.96 DSA

① ② ③ ④ ⑤ ⑥ ⑦

Crimp contact

DF 63 - 1618 SCF

⑧ ⑨

① Series name : DF	④ Number of Contacts : 1,2,3,4,5,6	⑧ Applicable Conductor 1618 : 16 to 18 AWG 2022 : 20 to 22 AWG
② Series No. : 63	⑤ Connector type P : Header S : Crimp socket EP : In-line plug	⑨ Packaging SCF : Socket contacts-Reel-Tin plated SCFA : Socket contacts-Reel-Gold plated SC : Socket contacts-Pack-Tin plated SCA : Socket contacts-Pack-Gold plated PCF : In-line plug contacts-Reel-Tin plated PCFA : In-line plug contacts-Reel-Gold plated PC : In-line plug contacts-Pack-Tin plated PCA : In-line plug contacts-Pack-Gold plated
③ Form Type Header Blank or M : Black R : Guide post-Guide Key Type, white Sockets Blank : Black R : Guide Key Type, white In-line Plugs Blank : Panel Lock Type A : Without Panel Lock		
	⑦ Type of housing DSA : Straight header DS : Right angle header C : Crimp housing	

Straight Header



Recommended PCB Layout (Board thickness : 1.6±0.1)

[1 to 6 pos.]

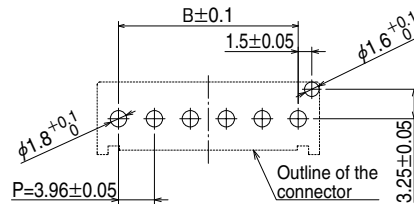

[1 pos.]

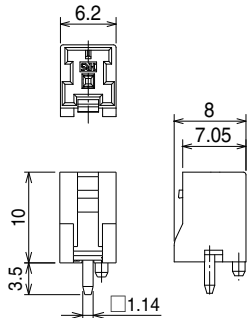

[2 to 6 pos.]

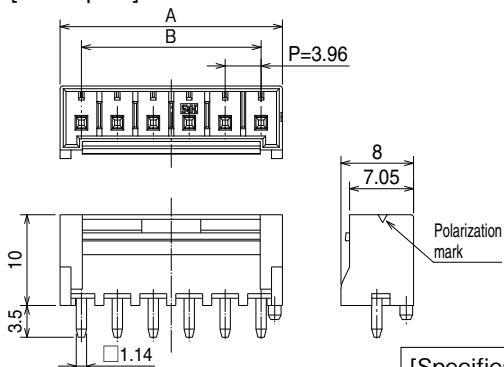

[Specification number]**
None : Tin plated
(01) : Gold plated

Standard Type (Guide post : Left Side, Color : Black)

Unit : mm

Part No.	HRS No.	No. of Contacts	A	B
DF63M-1P-3.96DSA(**)	680-0566-0 **	1	6.2	-
DF63M-2P-3.96DSA(**)	680-0567-0 **	2	8.66	3.96
DF63M-3P-3.96DSA(**)	680-0568-0 **	3	12.62	7.92
DF63M-4P-3.96DSA(**)	680-0569-0 **	4	16.58	11.88
DF63-5P-3.96DSA(**)	680-0506-7 **	5	20.54	15.84
DF63-6P-3.96DSA(**)	680-0507-0 **	6	24.50	19.80

R Type (Guide post : Right Side, Guide key, Color : White)

Part No.	HRS No.	No. of Contacts	A	B
DF63R-5P-3.96DSA(**)	680-0520-8 **	5	20.54	15.84

7.92mm pitch

Part No.	HRS No.	No. of Contacts	A	B
DF63M-2P-7.92DSA(**)	680-0581-0 **	2	12.62	7.92
DF63-3P-7.92DSA(**)	680-0537-0 **	3	20.54	15.84
DF63R-3P-7.92DSA(**)	680-0562-0 **			

Note 1 : Bag packaging (100 pcs/pack). Order by number of packs.

Note 2 : Please contact Hirose representative if you have request for (01) specification.

Right Angle Header

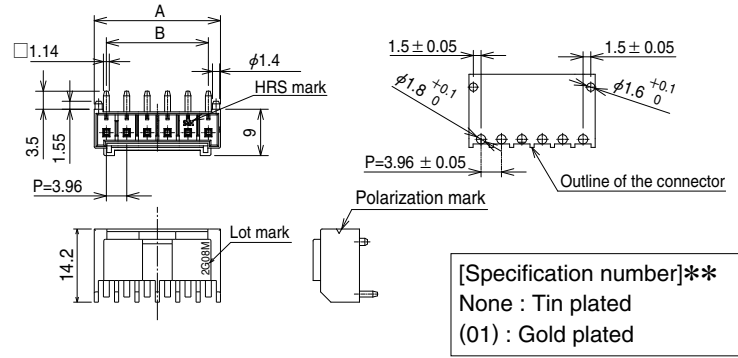

Standard Type (Color : Black)

Unit : mm

Part No.	HRS No.	No. of Contacts	A	B
DF63M-1P-3.96DS(**)	680-0570-0 **	1	6.2	-
DF63M-2P-3.96DS(**)	680-0571-0 **	2	8.66	3.96
DF63M-3P-3.96DS(**)	680-0572-0 **	3	12.62	7.92
DF63-4P-3.96DS(**)	680-0545-0 **	4	16.58	11.88
DF63-5P-3.96DS(**)	680-0546-0 **	5	20.54	15.84
DF63-6P-3.96DS(**)	680-0547-0 **	6	24.50	19.80

7.92mm pitch

Part No.	HRS No.	No. of Contacts	A	B
DF63M-2P-7.92DS(**)	680-0583-0 **	2	12.62	7.92
DF63-3P-7.92DS(**)	680-0559-0 **	3	20.54	15.84

Note 1 : Bag packaging (100 pcs/pack). Order by number of packs.

Note 2 : Please contact Hirose representative if you have request for (01) specification.

Crimp Socket

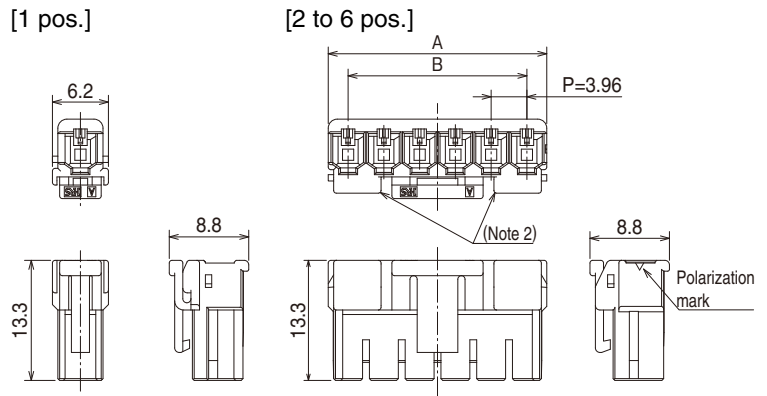

Standard Type

Unit : mm

Part No.	HRS No.	No. of Contacts	A	B
DF63-1S-3.96C(**)	680-0508-2 **	1	6.2	-
DF63-2S-3.96C(**)	680-0509-5 **	2	8.36	3.96
DF63-3S-3.96C(**)	680-0502-6 **	3	12.32	7.92
DF63-4S-3.96C(**)	680-0510-4 **	4	16.28	11.88
DF63-5S-3.96C(**)	680-0511-7 **	5	20.24	15.84
DF63-6S-3.96C(**)	680-0512-0 **	6	24.20	19.80

[Specification number]**
None : Black

R Type (Guide key)

Part No.	HRS No.	No. of Contacts	A	B
DF63R-5S-3.96C(**)	680-0525-1 **	5	20.24	15.84

[Specification number]**
None : White

Note 1 : Bag packaging (100 pcs/pack). Order by number of packs.

In-line Plug (Panel Lock Type)

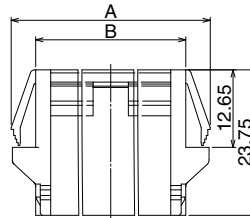
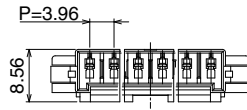

Polarization mark

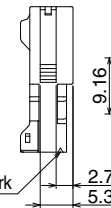

Recommended Panel Cutout

[1 pos.]

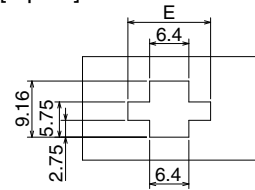

[2 to 6 pos.]

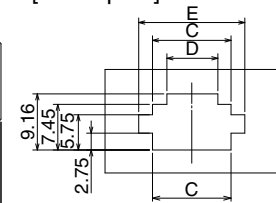

[Specification number]**
None : Black

Unit : mm

Part No.	HRS No.	No. of Contacts	A	B	C	D
DF63-1EP-3.96C(**)	680-0551-0 **	1	14.2	6.2	—	—
DF63-2EP-3.96C(**)	680-0533-0 **	2	16.66	8.66	8.86	4.96
DF63-3EP-3.96C(**)	680-0532-7 **	3	20.62	12.62	12.82	8.32
DF63-4EP-3.96C(**)	680-0552-0 **	4	24.58	16.58	16.78	12.28
DF63-5EP-3.96C(**)	680-0553-0 **	5	28.54	20.54	20.74	16.24
DF63-6EP-3.96C(**)	680-0554-0 **	6	32.5	24.5	24.7	20.2

E	Panel thickness	No. of Contacts					
		1	2	3	4	5	6
	0.5 to 0.6	10.3	12.76	16.72	20.68	24.64	28.6
	0.7 to 1.1	10.8	13.26	17.22	21.18	25.14	29.1
	1.2 to 1.7	11.3	13.76	17.72	21.68	25.64	29.6
	2.0 to 2.3	11.8	14.26	18.22	22.18	26.14	30.1

Note 1 : Bag packaging (100 pcs/pack). Order by number of packs.

In-line Plug

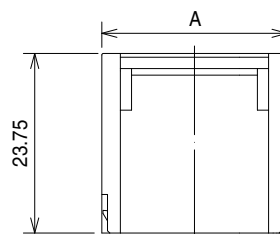
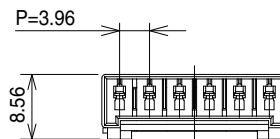

Polarization mark

Unit : mm

Part No.	HRS No.	No. of Contacts	A
DF63A-1EP-3.96C(**)	680-0555-0 **	1	6.2
DF63A-2EP-3.96C(**)	680-0535-5 **	2	8.66
DF63A-3EP-3.96C(**)	680-0534-2 **	3	12.62
DF63A-4EP-3.96C(**)	680-0556-0 **	4	16.58
DF63A-5EP-3.96C(**)	680-0557-0 **	5	20.54
DF63A-6EP-3.96C(**)	680-0558-0 **	6	24.5

[Specification number]**
None : Black

Note 1 : Bag packaging (100 pcs/pack). Order by number of packs.

■Crimp Contact for Socket

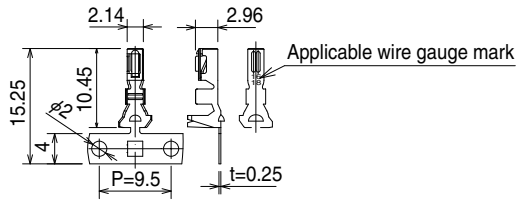

●Crimp Contact extraction tool

DF-C-PO(B), Flat-bladed screwdriver, 1.2mm blade width

●Strip length

2.9 to 3.6mm

◆Reel Contact (1Reel, 4,000 reel contacts) *Applicable tool : Applicator

Part No.	HRS No.	Finish	Applicable wire (tin plated annealed copper) (Note 1)					RoHs
			UL	Wire size	Stranded wire structure	Calculated cross-section	Jacket Diameter	
DF63-1618SCF	680-0500-0	Tin plated	1007	16 AWG	26 / 0.254mm	1.317mm ²	φ2.1 to 3.2mm	○
			1015	18 AWG	34 / 0.18mm	0.865mm ²		
DF63-1618SCFA	680-0540-0	Gold plated	1007	16 AWG	26 / 0.254mm	1.317mm ²	φ2.1 to 3.2mm	
			1015	18 AWG	34 / 0.18mm	0.865mm ²		
DF63-2022SCF	680-0541-0	Tin plated	1007	20 AWG	21 / 0.18mm	0.534mm ²	φ1.5 to 1.7mm	
				22 AWG	17 / 0.16mm	0.342mm ²		
DF63-2022SCFA	680-0574-0	Gold plated	1007	20 AWG	21 / 0.18mm	0.534mm ²	φ1.5 to 1.7mm	
				22 AWG	17 / 0.16mm	0.342mm ²		

Note 1 : When using a wire other than the applicable wires please contact a Hirose representative.

◆Loose piece (1 pack, 100) *Applicable tool: hand crimping tool

Part No.	HRS No.	Finish	Applicable wire (tin plated annealed copper) (Note 1)					RoHs
			UL	Wire size	Stranded wire structure	Calculated cross-section	Jacket Diameter	
DF63-1618SC	680-0514-5	Tin plated	1007	16 AWG	26 / 0.254mm	1.317mm ²	2.5mm	○
				18 AWG	34 / 0.18mm	0.865mm ²	2.1mm	
			1015	16 AWG	26 / 0.254mm	1.317mm ²	3.2mm	
				18 AWG	34 / 0.18mm	0.865mm ²	2.9mm	
DF63-1618SCA	680-0542-0	Gold plated	1007	16 AWG	26 / 0.254mm	1.317mm ²	2.5mm	
				18 AWG	34 / 0.18mm	0.865mm ²	2.1mm	
			1015	16 AWG	26 / 0.254mm	1.317mm ²	3.2mm	
				18 AWG	34 / 0.18mm	0.865mm ²	2.9mm	
DF63-2022SC	680-0549-0	Tin plated	1007	20 AWG	21 / 0.18mm	0.534mm ²	1.7mm	
				22 AWG	17 / 0.16mm	0.342mm ²	1.5mm	

Note 1 : When crimping using a hand crimping tool only the above wires are applicable.

■Crimp Contact for In-line Plug

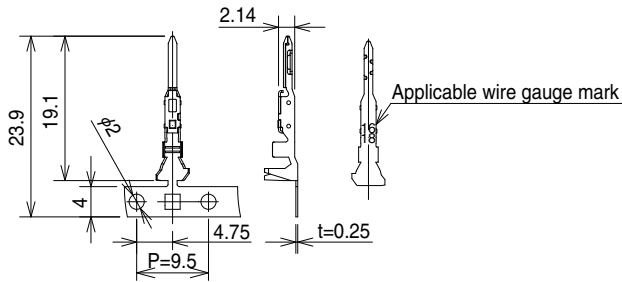

●Crimp Contact extraction tool

DF-C-PO(B), Flat-bladed screwdriver, 1.2mm blade width

●Strip length

2.9 to 3.6mm

◆Reel Contact (1Reel, 4,000 reel contacts) *Applicable tool : Applicator

Part No.	HRS No.	Finish	Applicable wire (tin plated annealed copper) (Note 1)					RoHs
			UL	Wire size	Stranded wire structure	Calculated cross-section	Jacket Diameter	
DF63-1618PCF	680-0529-2	Tin plated	1007	16 AWG	26 / 0.254mm	1.317mm ²	φ2.1 to 3.2mm	○
			1015	18 AWG	34 / 0.18mm	0.865mm ²		
DF63-1618PCFA	680-0636-0	Gold plated	1007	16 AWG	26 / 0.254mm	1.317mm ²	φ2.1 to 3.2mm	
			1015	18 AWG	34 / 0.18mm	0.865mm ²		
DF63-2022PCF	680-0538-3	Tin plated	1007	20 AWG	21 / 0.18mm	0.534mm ²	φ1.5 to 1.7mm	
				22 AWG	17 / 0.16mm	0.342mm ²		
DF63-2022PCFA	680-0638-0	Gold plated	1007	20 AWG	21 / 0.18mm	0.534mm ²	φ1.5 to 1.7mm	
				22 AWG	17 / 0.16mm	0.342mm ²		

Note 1 : When using a wire other than the applicable wires please contact a Hirose representative.

◆Loose piece (1 pack, 100) *Applicable tool: hand crimping tool

Part No.	HRS No.	Finish	Applicable wire (tin plated annealed copper) (Note 1)					RoHs
			UL	Wire size	Stranded wire structure	Calculated cross-section	Jacket Diameter	
DF63-1618PC	680-0536-8	Tin plated	1007	16 AWG	26 / 0.254mm	1.317mm ²	2.5mm	○
				18 AWG	34 / 0.18mm	0.865mm ²	2.1mm	
			1015	16 AWG	26 / 0.254mm	1.317mm ²	3.2mm	
				18 AWG	34 / 0.18mm	0.865mm ²	2.9mm	
DF63-2022PC	680-0539-6	Tin plated	1007	20 AWG	21 / 0.18mm	0.534mm ²	1.7mm	
				22 AWG	17 / 0.16mm	0.342mm ²	1.5mm	

Note 1 : When crimping using a hand crimping tool only the above wires are applicable.

◆Applicable Crimping Tool

Type	Part No.	HRS No.	Wire type	Applicable Contacts
Applicator	AP105-DF63-1618S-1	901-4634-1	UL1007 (Note 3)	DF63-1618SCF DF63-1618SCFA
	AP105-DF63-1618S-2	901-4635-4	UL1015 (Note 3)	
	CHS893400H-UP (Note 8)	—	UL1015	
	AP105-DF63-1618-3	901-4642-0	UL1007 (Note 3)	DF63-1618PCF DF63-1618PCFA
	AP105-DF63-1618-4	901-4643-2	UL1015 (Note 3)	
	CHS893500H-UP (Note 8)	—	UL1015	
AP105-DF63-2022-1	901-4617-0	UL1007 (Note 3)	DF63-2022SCF DF63-2022SCFA DF63-2022PCF DF63-2022PCFA	
Hand tool	HT802/DF63-1618S-1	550-0411-2	UL1007 (Note 4, 5)	DF63-1618SC DF63-1618SCA
	HT802/DF63-1618S-2	550-0413-8	UL1015 (Note 4, 6)	
	HT802/DF63-1618P-1	550-0423-1	UL1007 (Note 4, 5)	DF63-1618PC DF63-1618PCA
	HT802/DF63-1618P-2	550-0424-4	UL1015 (Note 4, 6)	
	HT802/DF63-2022S-1	550-0432-0	UL1007 (Note 4, 7)	DF63-2022SC DF63-2022SCA
	HT802/DF63-2022P-1	550-0433-0		DF63-2022PC DF63-2022PCA

Note 1 : Please conduct crimping work according to the "Crimping quality control statement of standards (ETAD-H0730-00, ETAD-H0810-00)" and "Crimping condition table".

Note 2 : Any problems that occur from using tools other than those specified by Hirose, are not covered by warranty.

Note 3 : Applicator dies can be switched to crimp the other wire size and type. The additional dies are sold separately.

Note 4 : Hand tool dies cannot be switched.

Note 5 : The compatible wire is limited to UL1007, 16 to 18 AWG

Note 6 : The compatible wire is limited to UL1015, 16 to 18 AWG

Note 7 : The compatible wire is limited to UL1007, 20 to 22 AWG

Note 8 : Applicator manufactured by JAPAN AUTOMATIC MACHINE (J.A.M.). Please access to HP of J.A.M., if you make inquiries about the applicator or crimp defect. (URL : <http://www.jam-net.co.jp>)

◆ Contact Extraction

- Contact extraction tool : Flat-bladed screwdriver. 1.2mm blade width or DF-C-PO(B)
- Intended crimp Contacts : DF63-1618SC(F), DF63-2022SC(F), DF63-1618PC(F), DF63-2022PC(F)
- Work Method

Housing Cross Sectional Diagram

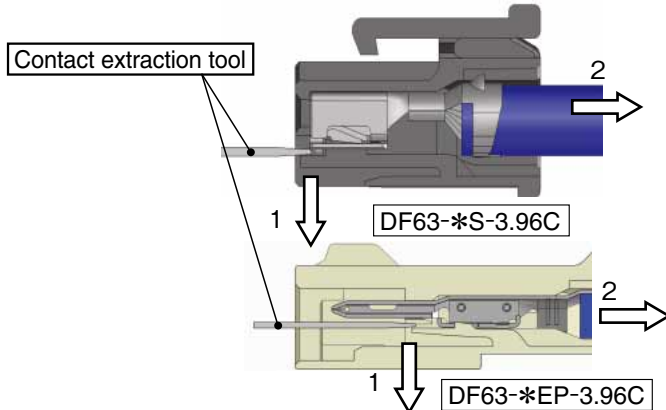

1. Refer to the drawing No.1. Insert correct size contact extraction tool in the insulator against the molded-in lance. Deflect the lance as shown.
2. Assure that the lance is deflected to release the contact and pull-out wire with the terminated contact.

*Using crimping socket after repair could induce decrease of lance strength, use new socket to avoid such failures.

Caution There are parts on the crimp contact that can cause injuries, please use caution when unmating the contacts.

◆ Mated dimensions

● Board-to-Wire Connection using the straight pin header

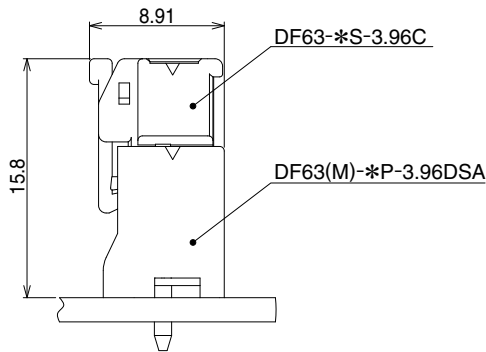

● Socket to Right Angle Header Connection

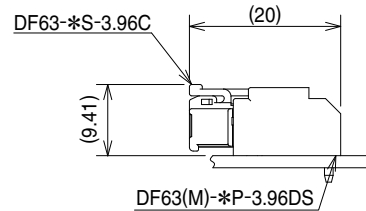

● Socket to In-line Plug Connection

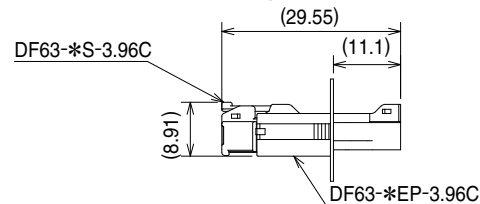

◆ Precautions for use

1. The connector could be damaged if it is pulled out forcibly. When it is hard to pull out, push it in slightly first and then depress the lock and un-mate.
2. When thick, short sections of wire are used, the connector could be deformed due to the force of the wires' position. Route cables in such a way that they do not twist when being installed.
3. Make sure to turn off the power when mating or un-mating the connector.
4. Please do not touch any area around the contact part with your hand when the power is on; it could be very dangerous.
5. Please reference the materials listed below when handling this product.
 - Crimping quality control statement of standards (ETAD-H0730-00, ETAD-H0810-00)
 - Harness procedure manual (ETAD-H0737-00)
 - Insertion/extraction manual (ETAD-H0892-00)
 - Wire to Board connector usage guide

◆ Rated values

Please avoid using the connectors above the ratings. Also, do not insert or pull out energized or "live" wires.

◆ Operating environment

Please contact us if you are designing this connector into environmental conditions where high and low temperatures are repeated.





HIROSE ELECTRIC CO.,LTD.

2-6-3,Nakagawa Chuoh,Tsuzuki-Ku,Yokohama-Shi 224-8540,JAPAN
 TEL: +81-45-620-3526 Fax: +81-45-591-3726
<http://www.hirose.com>
<http://www.hirose-connectors.com>

Looking for pricing, stock, or lifecycle information?

Click below to explore more details on WIN SOURCE:

-  [View DF63-3S-3.96C on WIN SOURCE](#)
-  [Hirose Electric Co Ltd Information](#)

Optimize Your Supply Chain with WIN SOURCE Solutions

-  Global Sourcing Solution
-  Obsolete Management
-  Cost Control Management
-  Shortage Management
-  Alternative Solution
-  Excess Inventory Management