



**THE DATASHEET OF
TLK2521IPAPG4**



TLK2521

1.0 to 2.5 Gbps 18-BIT SERDES

SLLS574D – JULY 2003 – REVISED JULY 2007

- Hot Plug Protection
- 1 to 2.5 Gigabits Per Second (Gbps) Serializer/Deserializer
- High-Performance 64-Pin HTQFP Thermally Enhanced Package (PowerPAD™)
- 2.5-V Power Supply for Low Power Operation
- Selectable Signal Preemphasis Serial Output
- Interfaces to Backplane, Copper Cables, or Optical Converters
- Lock Indication and Sync Mode for Fast Initialization
- 18-Bit Parallel Busses for Flexible Interface Applications
- On-chip PLL Provides Clock Synthesis From Low-Speed Reference
- Receiver Differential Input Thresholds 200 mV Min
- Rated for Industrial Temperature Range
- Power: 424 mW at 2.5 Gbps
- Ideal for High-Speed Backplane Interconnect and Point-to-Point Data Link
- Passive Receive Equalizer

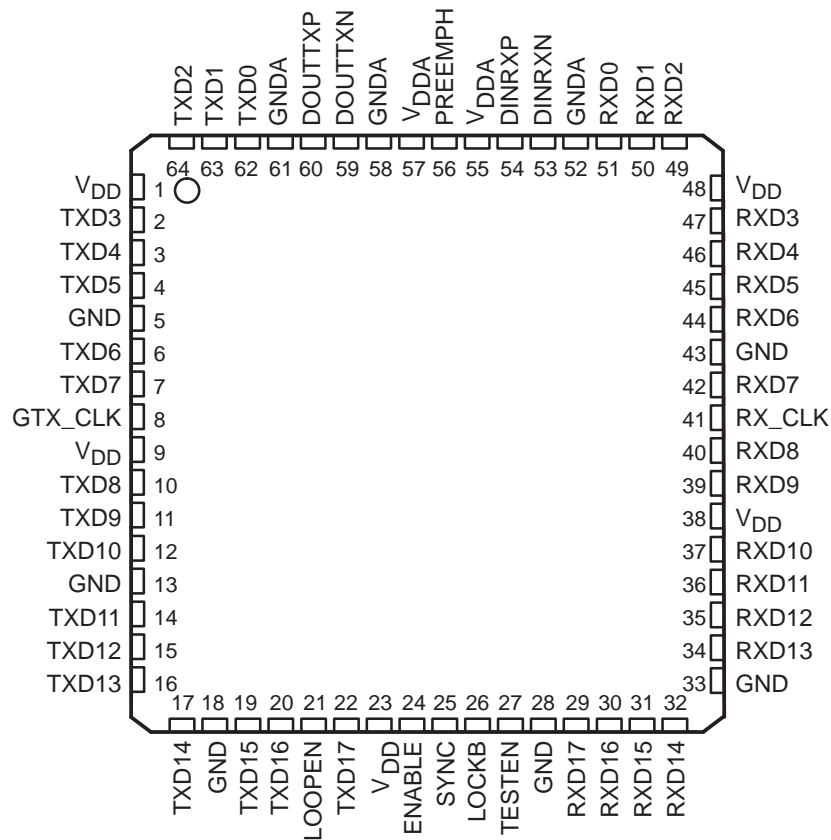

Please be aware that an important notice concerning availability, standard warranty, and use in critical applications of Texas Instruments semiconductor products and disclaimers thereto appears at the end of this data sheet.

PowerPAD is a trademark of Texas Instruments.

PRODUCTION DATA information is current as of publication date. Products conform to specifications per the terms of Texas Instruments standard warranty. Production processing does not necessarily include testing of all parameters.



POST OFFICE BOX 655303 • DALLAS, TEXAS 75265

Copyright © 2003 – 2007, Texas Instruments Incorporated

TLK2521

1.0 to 2.5 Gbps 18-BIT SERDES

SLLS574D – JULY 2003 – REVISED JULY 2007

description

The TLK2521 is a member of the WizardLink family of multi-gigabit transceivers, intended for use in high-speed bidirectional point-to-point data transmission systems. The TLK2521 supports an effective serial interface speed of 1 Gbps to 2.5 Gbps, providing up to 2.25 Gbps of data bandwidth.

The primary application of the TLK2521 is to provide high-speed I/O data channels for point-to-point baseband data transmission over controlled impedance media of approximately 50 Ω . The transmission media can be printed circuit board, copper cables, or fiber-optic cable. The maximum rate and distance of data transfer is dependent upon the attenuation characteristics of the media and the noise coupling to the environment.

The TLK2521 can also be used to replace parallel data transmission architectures by providing a reduction in the number of traces, connector pins, and transmit/receive pins. Parallel data loaded into the transmitter is delivered to the receiver over a serial channel, which can be a coaxial copper cable, a controlled impedance backplane, or an optical link. The data is then reconstructed into its original parallel format. It offers significant power and cost savings over current solutions, as well as scalability for higher data rate in the future.

The TLK2521 performs the data parallel-to-serial, serial-to-parallel conversion, and clock extraction functions for a physical layer interface device. The serial transceiver interface operates at a maximum speed of 2.5 Gbps. The transmitter latches 18-bit parallel data at a rate based on the supplied reference clock (GTX_CLK). The 18-bit parallel data is internally encoded into 20 bits by framing the 18-bit data with a start and a stop bit. The resulting 20-bit word is then transmitted differentially at 20 times the reference clock (GTX_CLK) rate. The receiver section performs the serial-to-parallel conversion on the input data synchronizing the resulting 20-bit wide parallel data to the extracted reference clock (RX_CLK). It then extracts the 18 bits of data from the 20-bit wide data resulting in 18 bits of parallel data at the receive data pins (RXD0–17). This results in an effective data payload of 900 Mbps to 2.25 Gbps (18 bits data x GTX_CLK frequency).

The TLK2521 is housed in a high performance, thermally enhanced, 64-pin HTQFP PowerPAD package. Use of the PowerPAD package does not require any special considerations except to note that the PowerPAD, which is an exposed die pad on the bottom of the device, is a metallic thermal and electrical conductor. It is strongly recommended that the TLK2521 PowerPAD be soldered to the grounded thermal land on the board, since the PowerPAD also constitutes a major electrical ground connection for the TLK2521. All ac performance specifications in this data sheet are measured with the PowerPAD soldered to the test board.

The TLK2521 provides an internal loopback capability for self-test purposes. Serial data from the serializer is passed directly to the deserializer allowing the protocol device a functional self-check of the physical interface.

The TLK2521 is designed to be hot plug capable. An on-chip power-on reset circuit holds the RX_CLK low and places the parallel side output signal pins, DOUUTXP and DOUUTXN, into a high-impedance state during power up.

The TLK2521 uses a 2.5-V supply. The I/O section is 3-V compatible. The TLK2521 is characterized for operation from -40°C to 85°C .

functional block diagram

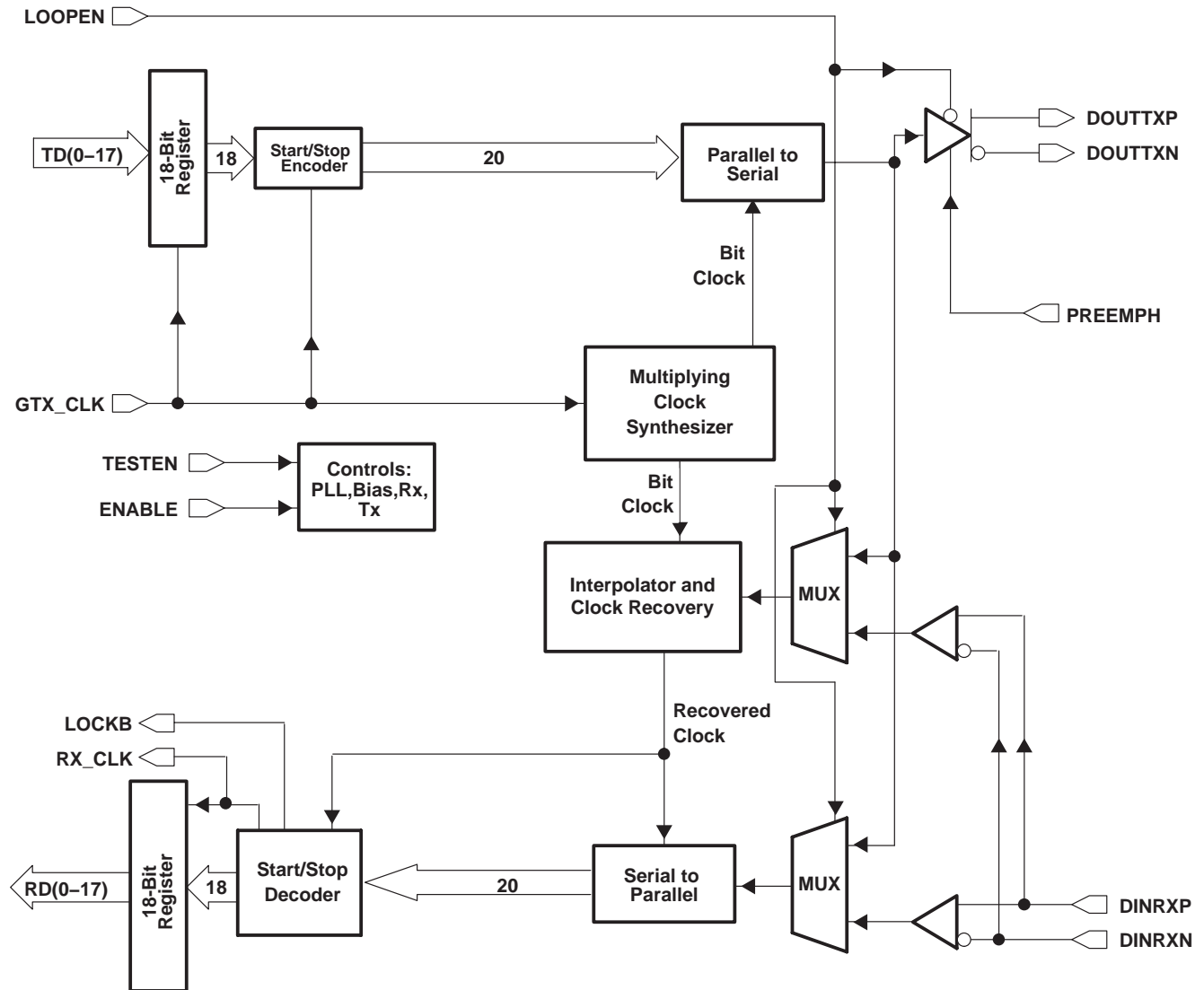

transmit interface

The transmitter portion registers valid incoming 18-bit wide data (TXD[0:17]) on the rising edge of GTX_CLK. The data is then framed with a start and a stop bit, serialized and transmitted sequentially over the differential high-speed I/O channel. The clock multiplier multiplies the reference clock (GTX_CLK) by a factor of 10 times creating a bit clock. This internal bit clock is fed to the parallel-to-serial shift register, which transmits data on both the rising and falling edges of the bit clock providing a serial data rate that is 20 times the reference clock. Data is transmitted LSB (D0) first.

transmit data bus

The transmit bus interface accepts 18-bit wide single-ended TTL parallel data at the TXD[0:17] pins. Data is valid on the rising edge of GTX_CLK. The GTX_CLK is used as the word clock. The data and clock signals must be properly aligned as shown in Figure 1. Detailed timing information can be found in the *TTL input electrical characteristics* table.

TLK2521
1.0 to 2.5 Gbps 18-BIT SERDES

SLLS574D – JULY 2003 – REVISED JULY 2007

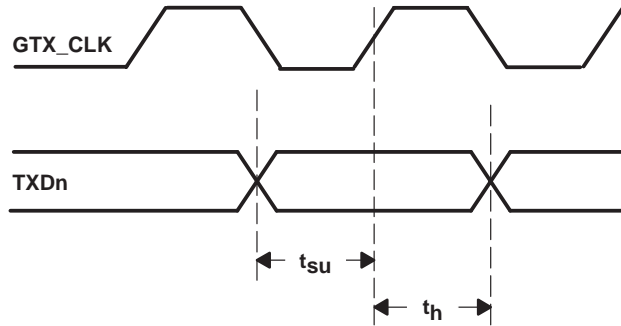

Figure 1. Transmit Timing Waveform

transmission latency

The data transmission latency of the TLK2521 is defined as the delay from the initial 18-bit word load to the serial transmission of bit 0. The transmit latency is fixed once the link is established. However, due to silicon process variations and implementation variables such as supply voltage and temperature, the exact delay varies slightly. Figure 2 illustrates the timing relationship between the transmit data bus, GTX_CLK, and serial transmit pins. Detailed latency information can be found in the *transmitter/receiver characteristics* table.

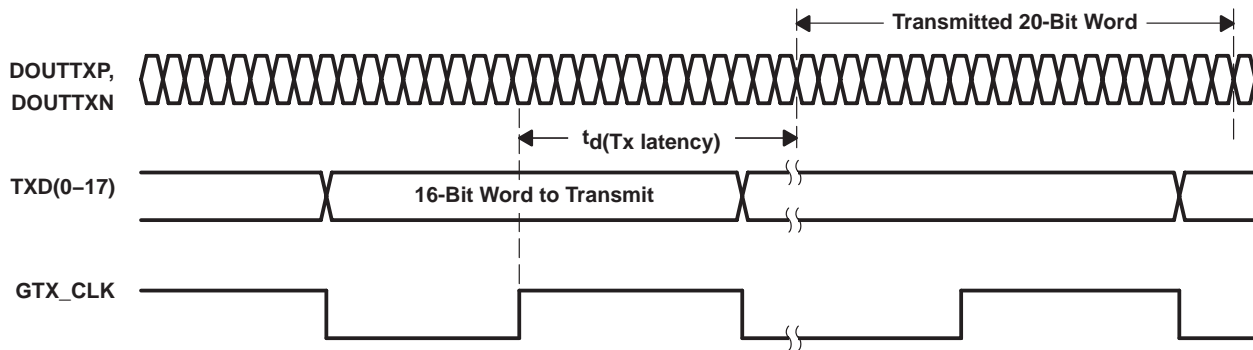

Figure 2. Transmitter Latency

start/stop framing logic

All true serial interfaces require a method of encoding to insure minimum transition density so that the receiving PLL has a minimal number of transitions in which to stay locked onto the data stream. The signal coding also provides a mechanism for the receiver to identify the byte boundary for correct deserialization. The TLK2521 wraps a start bit (1) and a stop bit (0) around the 18-bit data payload as shown in Figure 3. This is transparent to the user as the TLK2521 internally adds the framing bits to the data such that the user reads and writes actual 18-bit data.

start/stop framing logic (continued)



Figure 3. Serial Output Data Stream with Start and Stop Bit

parallel-to-serial

The parallel-to-serial shift register takes in the 20-bit wide data word multiplexed from the framing logic and converts it to a serial stream. The shift register is clocked on both the rising and falling edge of the internally generated bit clock, which is 10 times the GTX_CLK input frequency. The LSB (TD0) is transmitted first as shown in Figure 3.

high-speed data output

The high-speed data output driver consists of a PECL-compatible differential pair that can be optimized for a particular transmission line impedance and length. The line can be directly coupled or ac coupled. AC-coupling is only recommended if the parallel TX data stream is encoded to achieve a dc-balanced data stream. See Figure 11 and Figure 12 for termination details. No external pullup or pulldown resistors are required.

The TLK2521 provides a selectable signal preemphasis option for driving lossy media. The first bit of a run length of same-value bits is driven to a larger output swing, which precompensates for signal inter-symbol interference (ISI) in lossy media such as copper cables or printed circuit board traces due to preemphasis.

receive interface

The receiver portion of the TLK2521 accepts 20-bit framed differential serial data. The interpolator and clock recovery circuit locks to the data stream and extracts the bit rate clock. This recovered clock is used to retime the input data stream. The serial data is then aligned to the 20-bit word boundary by finding the start/stop bits, and the 18-bit data is output on a 18-bit wide parallel bus synchronized to the extracted receive clock.

receive data bus

The receive bus interface drives 18-bit wide single-ended TTL parallel data at the RXD[0:17] pins. Data is valid on the rising edge of RX_CLK. The RX_CLK is used as the recovered word clock. The data and clock signals are aligned as shown in Figure 4. Detailed timing information can be found in the TTL output switching characteristics table.

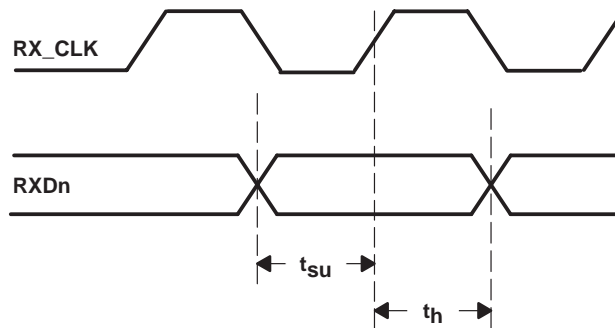

Figure 4. Receive Timing Waveform

TLK2521

1.0 to 2.5 Gbps 18-BIT SERDES

SLLS574D – JULY 2003 – REVISED JULY 2007

data reception latency

The serial-to-parallel data receive latency is the time from when the first bit arrives at the receiver until it is output in the aligned parallel word with RXD0 received as first bit. The receive latency is fixed once the link is established. However, due to silicon process variations and implementation variables such as supply voltage and temperature, the exact delay varies slightly. Figure 5 illustrates the timing relationship between the serial receive pins, the recovered word clock (RX_CLK), and the receive data bus. Detailed latency information can be found in the transmitter/receiver characteristics table.

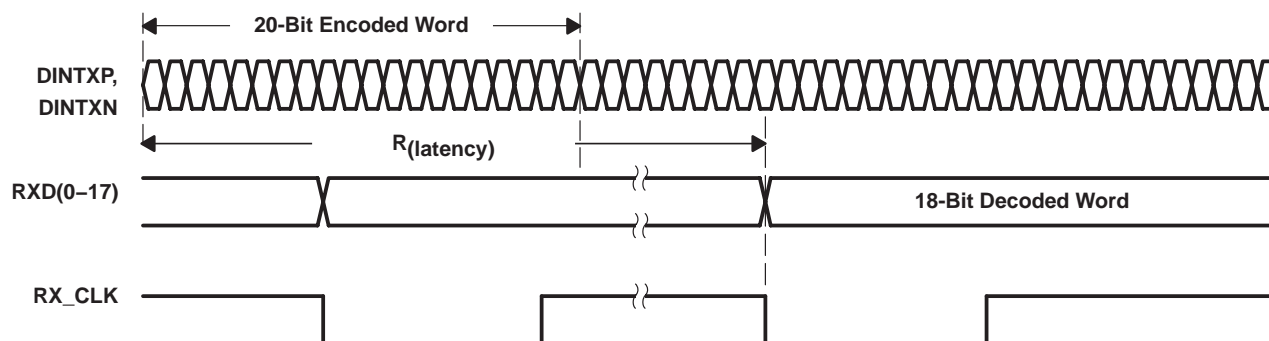

Figure 5. Receiver Latency

serial-to-parallel

Serial data is received on the DINRXP and DINRXN pins. The interpolator and clock recovery circuit locks to the data stream if the clock to be recovered is within ± 100 PPM of the internally generated bit rate clock. The recovered clock is used to retiming the input data stream. The serial data is then clocked into the serial-to-parallel shift registers.

synchronization mode

The deserializer PLL must synchronize to the serializer in order to receive valid data. Synchronization can be accomplished in one of two ways.

rapid synchronization

The serializer has the capability to send specific SYNC patterns consisting of nine ones and nine zeros, switching at the input clock rate. The transmission of SYNC patterns enables the deserializer to lock to the serializer signal within a deterministic time frame. The transmission of SYNC patterns is selected via the SYNC input on the serializer. Upon receiving a valid SYNC pulse (wider than 6 clock cycles), 1026 cycles of SYNC pattern are sent.

When the deserializer detects edge transitions at the serial input, it attempts to lock to the embedded clock information. The deserializer LOCKB output remains inactive while its clock/data recovery (CDR) locks to the incoming data or SYNC patterns present on the serial input. When the deserializer locks to the serial data, the LOCKB output goes active. When LOCKB is active, the deserializer outputs represent incoming serial data. One approach is to tie the deserializer LOCKB output directly to the SYNC input of the transmitter.

random lock synchronization

The deserializer can attain lock to a data stream without requiring the serializer to send special SYNC patterns. This allows the TLK2521 to operate in open-loop applications. Equally important is the deserializer's ability to support hot insertion into a running backplane. In the open-loop or hot-insertion case, it is assumed the data stream is essentially random. Therefore, because lock time varies due to data stream characteristics, the exact lock time cannot be predicted. The primary constraint on the random lock time is the initial phase relation between the incoming data and the GTX_CLK when the deserializer powers up.

random lock synchronization (continued)

The data contained in the data stream can also affect lock time. If a specific pattern is repetitive, the deserializer could enter false lock—falsely recognizing the data pattern as the start/stop bits. This is referred to as repetitive multitransition (RMT). This occurs when more than one low-high transition takes place per clock cycle over multiple clock cycles. In the worst case, the deserializer could become locked to the data pattern rather than the clock. Circuitry within the deserializer can detect that the possibility of false lock exists. Upon detection, the circuitry prevents the LOCKB from becoming active until the potential false-lock pattern changes. Notice that the RMT pattern only affects the deserializer lock time, and once the deserializer is in lock, the RMT pattern does not affect the deserializer state as long as the same data boundary happens each cycle. The deserializer does not go into lock until it finds a unique data boundary that consists of four consecutive start/stop bits at the same position.

The deserializer stays in lock until it cannot detect the same data boundary (start/stop bits) for four consecutive cycles. Then the deserializer goes out of lock and hunts for the new data boundary (start/stop bits). In the event of loss of synchronization, the LOCKB pin output goes inactive and the outputs (including RX_CLK) enter a high-impedance state. The user's system should monitor the LOCKB pin in order to detect a loss of synchronization. Upon detection of loss of lock, sending SYNC patterns for resynchronization is desirable if reestablishing lock within a specific time is critical. However, the deserializer can lock to random data as previously noted. LOCKB is held inactive for at least nine cycles after loss of lock is detected.

power-down mode

When the ENABLE pin is deasserted low, the TLK2521 goes into a power-down mode. In the power-down mode, the serial transmit pins (DOU_TXP, DOU_TXN) and the receive data bus pins (RXD[0:17]) go into a high-impedance state.

reference clock input

The reference clock (GTX_CLK) is an external input clock that synchronizes the transmitter interface. The reference clock is then multiplied in frequency 10 times to produce the internal serialization bit clock. The internal serialization bit clock is frequency locked to the reference clock and used to clock out the serial transmit data on both its rising and falling edge clock providing a serial data rate that is 20 times the reference clock.

The receiver tracking logic uses clock phases from the internal PLL as it aligns the recovered clock phase with the incoming serial data stream; therefore, the input reference clock (GTX_CLK) is needed even if the transmit function of the TLK2521 is not being used. The receiver function has the ability to track an incoming serial data stream that is within ± 200 ppm of the data rate that is set by GTX_CLK. This allows the use of clock sources with ± 100 ppm frequency tolerance.

operating frequency range

The TLK2521 may operate at a serial data rate between 1 Gbit/s to 2.5 Gbit/s. GTX_CLK must be within ± 100 PPM of the desired parallel data rate clock.

testability

The TLK2521 has a comprehensive suite of built-in self-tests. The loopback function provides for at-speed testing of the transmit/receive portions of the circuitry. The ENABLE pin allows for all circuitry to be disabled so that an IDDQ test can be performed.

loop-back testing

The transceiver can provide a self-test function by enabling (LOOPEN) the internal loop-back path. Enabling this pin causes serial transmitted data to be routed internally to the receiver. The parallel data output can be compared to the parallel input data for functional verification. (The external differential output is held in a high-impedance state during the loop-back testing.)

TLK2521

1.0 to 2.5 Gbps 18-BIT SERDES

SLLS574D – JULY 2003 – REVISED JULY 2007

power-on reset

Upon application of minimum valid power, the TLK2521 generates a power-on reset. During the power-on reset the RXD pins are tri-stated. RX_CLK is held low. The length of the power-on reset cycle is dependent upon the REFCLK frequency but is less than 1 ms in duration.

Terminal Functions

TERMINAL		TYPE	DESCRIPTION
NAME	NO.		
SIGNAL PIN			
DOU _{TXP}	60	Output (High-Z power up)	Serial transmit outputs. DOU _{TXP} and DOU _{TXN} are differential serial outputs that interface to copper or an optical I/F module. These terminals transmit NRZ data at a rate of 20 times the GTX_CLK value. DOU _{TXP} and DOU _{TXN} are put in a high-impedance state when LOOPEN is high and are active when LOOPEN is low. During power-on reset, these pins are high impedance.
DOU _{TXN}	59		
DIN _{RXP}	54	Input	Serial receive inputs. DIN _{RXP} and DIN _{RXN} together are the differential serial input interface from a copper or an optical I/F module.
DIN _{RXN}	53		
GTX_CLK	8	Input	Reference clock. GTX_CLK is a continuous external input clock that synchronizes the transmitter interface TXD. The frequency range of GTX_CLK is 50 MHz to 125 MHz. The transmitter uses the rising edge of this clock to register the 18-bit input data (TXD) for serialization.
TXD0	62	Input	Transmit data bus. These inputs carry the 18-bit parallel data output from a protocol device to the transceiver for encoding, serialization and transmission. This 18-bit parallel data is clocked into the transceiver on the rising edge of GTX_CLK as shown in Figure 9.
TXD1	63		
TXD2	64		
TXD3	2		
TXD4	3		
TXD5	4		
TXD6	6		
TXD7	7		
TXD8	10		
TXD9	11		
TXD10	12		
TXD11	14		
TXD12	15		
TXD13	16		
TXD14	17		
TXD15	19		
TXD16	20		
TXD17	22		
RXD0	51	Output (High-Z on power up)	Receive data bus. These outputs carry 18-bit parallel data output from the transceiver to the protocol device, synchronized to RX_CLK. The data is valid on the rising edge of RX_CLK as shown in Figure 10. These pins are 3-stated during power-on reset. These pins are also high impedance when enable=0.
RXD1	50		
RXD2	49		
RXD3	47		
RXD4	46		
RXD5	45		
RXD6	44		
RXD7	42		
RXD8	40		
RXD9	39		
RXD10	37		
RXD11	36		
RXD12	35		
RXD13	34		



TLK2521
1.0 to 2.5 Gbps 18-BIT SERDES

SLLS574D – JULY 2003 – REVISED JULY 2007

TERMINAL		TYPE	DESCRIPTION
NAME	NO.		
RXD14	32		
RXD15	31		
RXD16	30		
RXD17	29		
RX_CLK	41	Output (low on power up)	Recovered clock. Output clock that is synchronized to RXD. RX_CLK is the recovered serial data rate clock divided by 20. RX_CLK is held low during power-on reset. These pins are also high impedance when enable=0.
SYNC	25	Input (w/pulldown)	Fast synchronization. When asserted high, the transmitter substitute the 18-bit pattern 1111111100000000, so that when the start/stop bits are framed around the data the receiver can immediately detect the proper deserialization boundary. This is typically used during initialization of the serial link.
PREEMPH	56	Input	Preemphasis. When asserted, the serial transmit outputs have an extra output swing on the first bit of any run-length of same value bits than when deasserted.
TEST PIN			
ENABLE	24	Input (w/pullup)	Device enable. When this pin is held low, the device is placed in power down mode. When asserted high while the device is in power-down mode, the transceiver goes into power-on reset before beginning normal operation.
LOOPEN	21	Input (w/pulldown)	Loop enable. When LOOPEN is active high, the internal loop-back path is activated. The transmitted serial data is directly routed internally to the inputs of the receiver. This provides a self-test capability in conjunction with the protocol device. The DOUTTXP and DOUTTXN outputs are held in a high-impedance state during the loop-back test. LOOPEN is held low during standard operational state with external serial outputs and inputs active.
LOCKB	26	Output	Receiver lock. When asserted low, it indicates that the receiver has acquired bit synchronization on the data stream and has located the start/stop bits, so that the deserialized data presented on the parallel receive bus is properly received. These pins are also high impedance when enable=0.
TESTEN	27	Input (w/pulldown)	Test mode enable. This pin should be left unconnected or tied low.
POWER PIN			
VDD	1, 9, 23, 38, 48	Supply	Digital logic power. Provides power for all digital circuitry and digital I/O buffers.
VDDA	55, 57	Supply	Analog power. VDDA provides a supply reference for the high-speed analog circuits, receiver and transmitter.
GROUND PIN			
GNDA	52, 58, 61	Ground	Analog ground. GNDA provides a ground reference for the high-speed analog circuits, RX and TX.
GND	5, 13, 18, 28, 33, 43	Ground	Digital logic ground. Provides a ground for the logic circuits and digital I/O buffers.

TLK2521

1.0 to 2.5 Gbps 18-BIT SERDES

SLLS574D – JULY 2003 – REVISED JULY 2007

absolute maximum ratings over operating free-air temperature (unless otherwise noted)†

Supply voltage, V_{DD} (see Note 1)	–0.3 V to 3 V
Voltage range at TXD, ENABLE, GTX_CLK, LOOPEN, SYNC, PREEMPH	–0.3 V to 4 V
Voltage range at any other terminal except above	–0.3 V to $V_{CC} + 0.3$ V
Package power dissipation, P_D	See Dissipation Rating Table
Storage temperature, T_{stg}	–65°C to 150°C
Electrostatic discharge	HBM:2 kV, CDM:1.5 kV
Characterized free-air operating temperature range	–40°C to 85°C
Lead Temperature 1,6 mm (1/16 inch) from case for 10 seconds	260°C

† Stresses beyond those listed under “absolute maximum ratings” may cause permanent damage to the device. These are stress ratings only, and functional operation of the device at these or any other conditions beyond those indicated under “recommended operating conditions” is not implied. Exposure to absolute-maximum-rated conditions for extended periods may affect device reliability.

NOTE 1: All voltage values, except differential I/O bus voltages, are with respect to network ground.

DISSIPATION RATING TABLE

PACKAGE	$T_A \leq 25^\circ\text{C}$ POWER RATING	DERATING FACTOR† ABOVE $T_A = 25^\circ\text{C}$	$T_A = 70^\circ\text{C}$ POWER RATING
PAP64‡	3.22 W	32.15 mW/°C	1.77 W
PAP64§	0.94 W	9.46 mW/°C	0.52 W
PAP64¶	0.68 W	6.78 mW/°C	0.37 W

† This is the inverse of the traditional junction-to-ambient thermal resistance ($R_{\theta JA}$)

‡ High K-board with solder

§ High K-board without solder

¶ Low K-board

NOTE: For more information, see the TI application note *PowerPAD™ Thermally Enhanced Package*, TI (SLMA002).

electrical characteristics over recommended operating conditions

PARAMETER	TEST CONDITION	MIN	TYP	MAX	UNIT
V_{DD} Supply voltage		2.3	2.5	2.7	V
T_A Operating free-air temperature		–40		85	°C
I_{CC} Supply current	$V_{DD} = 2.5$ V, Freq = 1 Gb/sec, PRBS pattern		71		mA
	$V_{DD} = 2.5$ V, Freq = 2.5 Gb/sec, PRBS pattern		170		
P_D Power dissipation	$V_{DD} = 2.5$ V, Freq = 1 Gb/sec, PRBS pattern		178		mW
	$V_{DD} = 2.5$ V, Freq = 2.5 Gb/sec, PRBS pattern		424		
	$V_{DD} = 2.75$ V, Freq = 2.5 Gb/sec, worst case pattern			730	
Shutdown current	ENABLE = 0, VDDA, VDD pins, $V_{DD} = \text{max}$		130		μA
PLL startup lock time	V_{DD} , VDDA = 2.3 V, EN ↑ to PLL acquire		0.1	0.4	ms
Data acquisition time			1024		bits

reference clock (GTX_CLK) timing requirements over recommended operating conditions (unless otherwise noted)

PARAMETER	TEST CONDITIONS	MIN	TYP	MAX	UNIT
R_ω Frequency	Minimum data rate	TYP–0.01%	50	TYP+0.01%	MHz
	Maximum data rate	TYP–0.01%	125	TYP+0.01%	MHz
Frequency tolerance		–100		100	ppm
Duty cycle		40%	50%	60%	
Jitter#	Peak-to-peak			40	ps

See the *Reference Lock Jitter Analysis For TLK2521* application note for more information.



TTL input electrical characteristics over recommended operating conditions (unless otherwise noted)

TTL Signals: TXD0 ...TXD17, GTX_CLK, LOOPEN, SYNC, PREEMPH

PARAMETER	TEST CONDITIONS	MIN	TYP	MAX	UNIT
V_{IH}	High-level input voltage	See Figure 6	2	3.6	V
V_{IL}	Low-level input voltage	See Figure 6		0.8	V
I_{IH}	High-level input current	$V_{DD} = \text{MAX}, V_{IN} = 2 \text{ V}$		40	μA
I_{IL}	Low-level input current	$V_{DD} = \text{MAX}, V_{IN} = 0.4 \text{ V}$	-40		μA
C_{IN}	Input capacitance	0.8 V to 2 V		4	pF
t_r	GTX_CLK, TXD rise time	0.8 V to 2 V, C = 5 pF, See Figure 6	1		ns
t_f	GTX_CLK, TXD fall time	2 V to 0.8 V, C = 5 pF, See Figure 6	1		ns
t_{su}	TXD setup to \uparrow GTX_CLK	See Figure 6	1.5		ns
t_h	TXD hold to \uparrow GTX_CLK	See Figure 6	0.4		ns

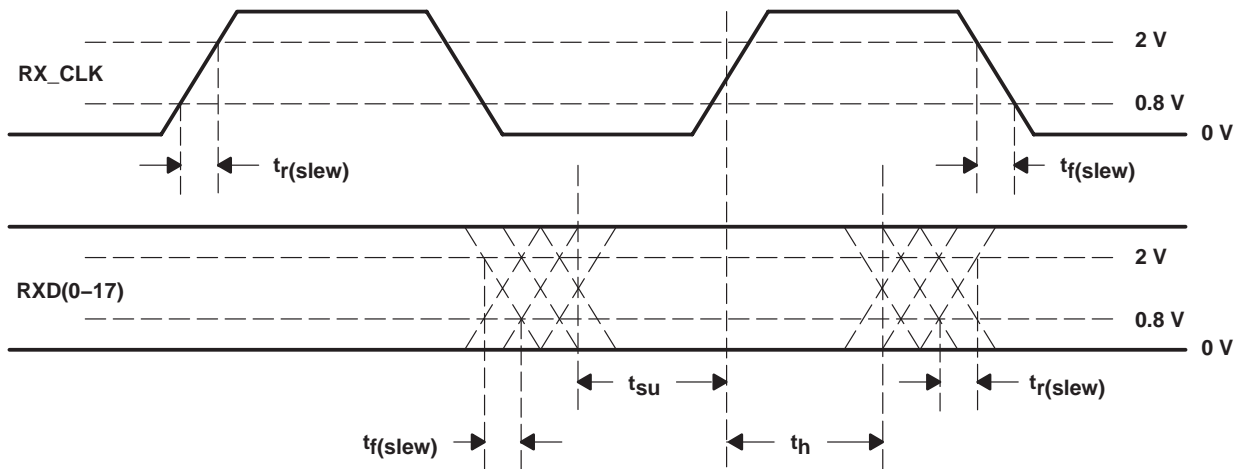

Figure 6. TTL Data Input Valid Levels for AC Measurements

TLK2521
1.0 to 2.5 Gbps 18-BIT SERDES

SLLS574D – JULY 2003 – REVISED JULY 2007

TTL output switching characteristics over recommended operating conditions (unless otherwise noted)

PARAMETER	TEST CONDITIONS	MIN	TYP	MAX	UNIT
V _{OH} High-level output voltage	I _{OH} = -1 mA, V _{DD} = MIN	2.1	2.3		V
V _{OL} Low-level output voltage	I _{OL} = 1 mA, V _{DD} = MIN	GND	0.25	0.5	V
t _{r(slew)} Magnitude of RX_CLK, RXD slew rate (rising)	0.8 V to 2 V, C = 5 pF, See Figure 10	0.5			V/ns
t _{f(slew)} Magnitude of RX_CLK, RXD slew rate (falling)	0.8 V to 2 V, C = 5 pF, See Figure 10	0.5			V/ns
t _{su} RXD setup to ↑ RX_CLK	50% voltage swing, GTX_CLK = 50 MHz, See Figure 7	8			ns
	50% voltage swing, GTX_CLK = 125 MHz, See Figure 7	3			ns
t _h RXD hold to ↑ RX_CLK	50% voltage swing, GTX_CLK = 50 MHz, See Figure 7	8			ns
	50% voltage swing, GTX_CLK = 125 MHz, See Figure 7	3			ns

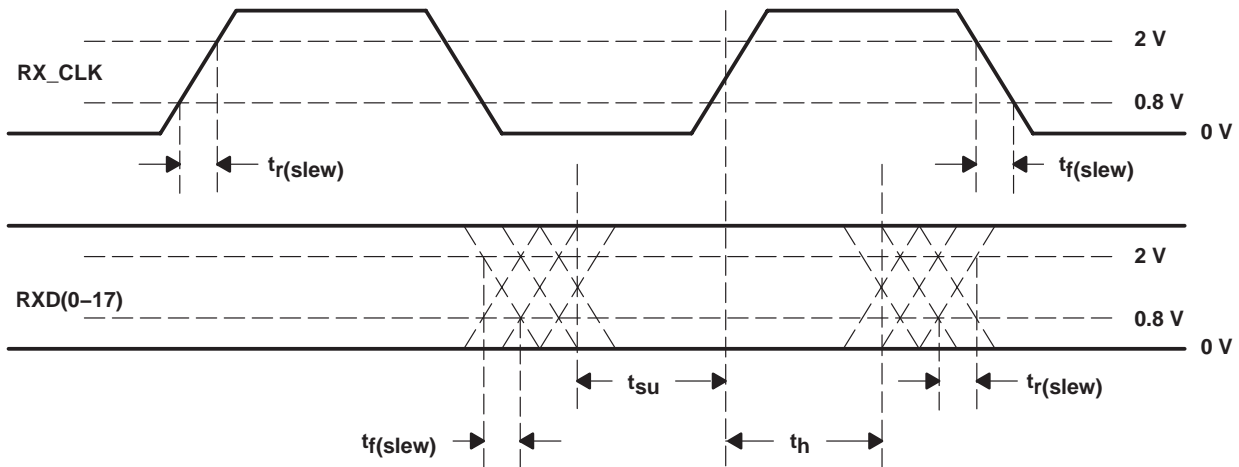

Figure 7. TTL Data Output Valid Levels for AC Measurements

transmitter/receiver characteristics

PARAMETER		TEST CONDITION	MIN	TYP	MAX	UNIT
V _{OD(p)}	V _{OD(p)} = VTXP-VTXN , Preemphasis VOD, direct	DC coupled. Preemphasis = high, See Figure 8	675	900	1280	mV
		DC coupled. Preemphasis = low, See Figure 8	600	800	1210	
V _{OD(pp-p)}	Differential, peak to peak output voltage with preemphasis	DC coupled. Preemphasis = high, See Figure 8	1350	1800	2560	mV
		DC coupled. Preemphasis = low, See Figure 8	1200	1600	2420	
V _{OD(d)}	VD(d) = VTXP-VTXN , De-emphasis VOD, direct	DC coupled. See Figure 8	500	750	1100	mV
V _{OD(pp-d)}	Differential, peak to peak output voltage with deemphasis	DC coupled. See Figure 8	1000	1500	2200	mV
V _(cmt)	Transmit termination voltage range, (VTXP + VTXN)/2		1000	1250	1400	mV
V _{ID}	Receiver input voltage differential VID= RXP - RXN		200			mV
V _{cmt}	Receiver common-mode voltage range, (VRXP + VRXN)/2		1000	V _{DD} -350		mV
I _{in}	Receiver input leakage		-10		10	μA
C _{in}	Receiver input capacitance				2	pF
t _t , t _f	Differential output signal rise, fall time (20% to 80%)	R _L = 50 Ω, C _L = 5 pF, See Figure 12	100	150		ps
	Serial transmit data total jitter (peak-to-peak)	Differential output jitter, random + deterministic, 2 ²³ -1 PRBS pattern at 2.5 Gbps		0.15		UI
	Receive jitter tolerance	Total input jitter, PRBS pattern, permitted eye closure at zero crossing		0.5		UI
T _{latency}	TX latency	At 1 Gbps	16		19	Bit times
		At 2.5 Gbps	18		21	
R _{latency}	RX latency	At 1 Gbps	88		95	Bit times
		At 2.5 Gbps	90		103	

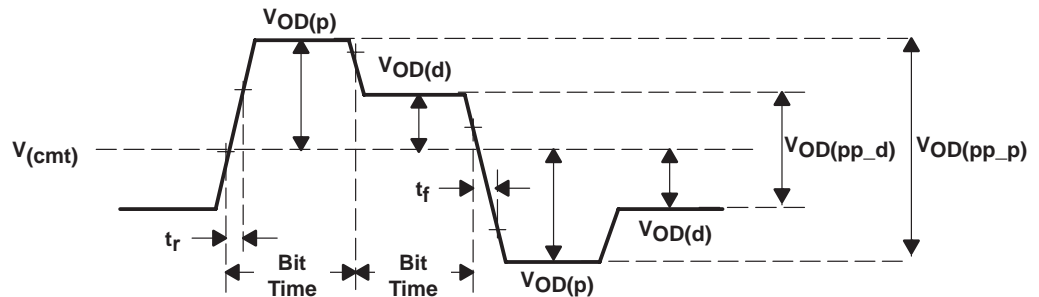

Figure 8. Differential and Common-Mode Output Voltage Definitions

TLK2521
1.0 to 2.5 Gbps 18-BIT SERDES

SLLS574D – JULY 2003 – REVISED JULY 2007

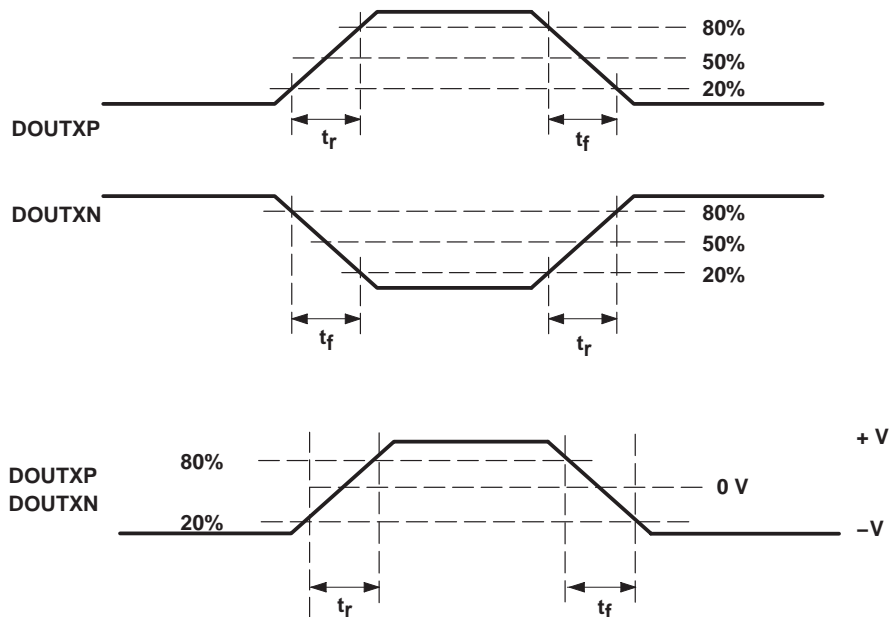

Figure 9. Rise and Fall Time Definitions

thermal characteristics

PARAMETER	TEST CONDITION	MIN	TYP	MAX	UNIT
R _{θJA} Junction-to-free-air thermal resistance	Board mounted, no air flow, high conductivity TI recommended test board, chip soldered or greased to thermal land	21.47			°C/W
R _{θJC} Junction-to-case thermal resistance		0.38			
R _{θJA} Junction-to-free-air thermal resistance	Board mounted, no air flow, high conductivity TI recommended test board with thermal land but no solder or grease thermal connection to thermal land	42.2			°C/W
R _{θJC} Junction-to-case thermal resistance		0.38			
R _{θJA} Junction-to-free-air thermal resistance	Board mounted, no air flow, JEDEC test board	75.83			°C/W
R _{θJC} Junction-to-case thermal resistance		7.8			

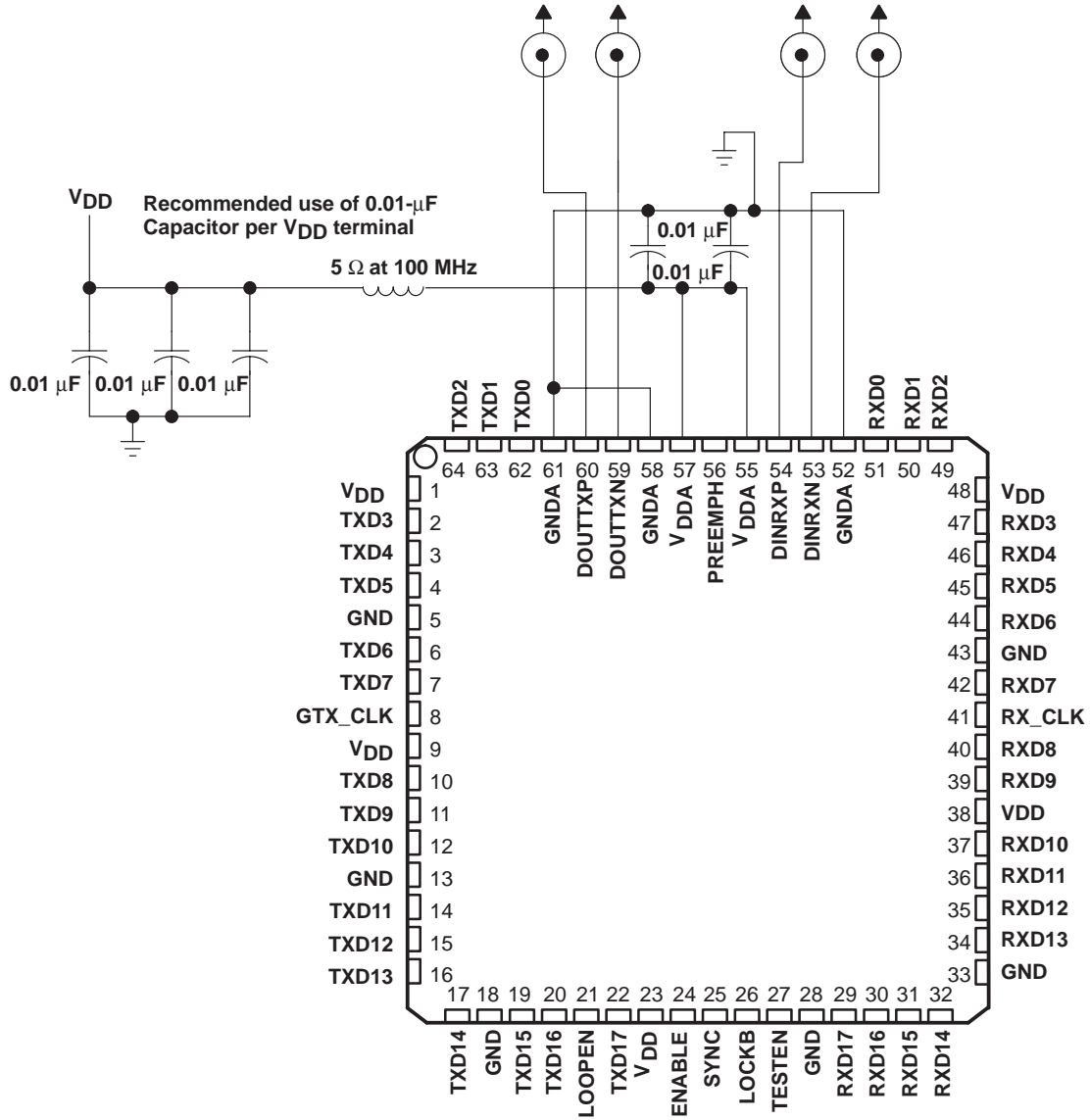

Figure 10. External Component Interconnection

ORDERING INFORMATION

	Orderable
TLK2521	TLK2521IPAP

TLK2521

1.0 to 2.5 Gbps 18-BIT SERDES

SLLS574D – JULY 2003 – REVISED JULY 2007

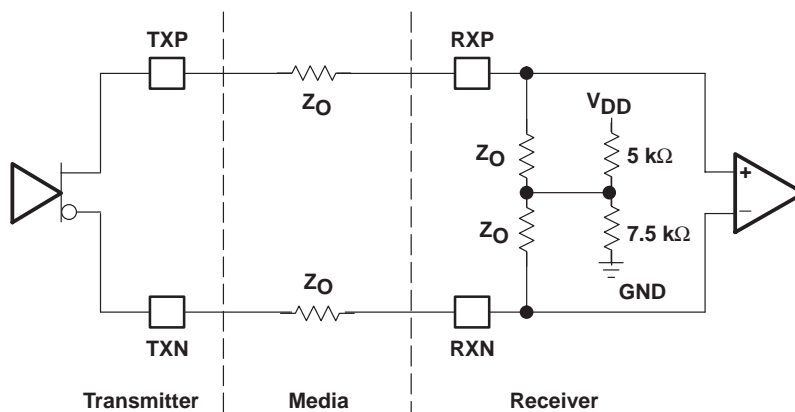

Figure 11. High-Speed I/O Directly Coupled Mode

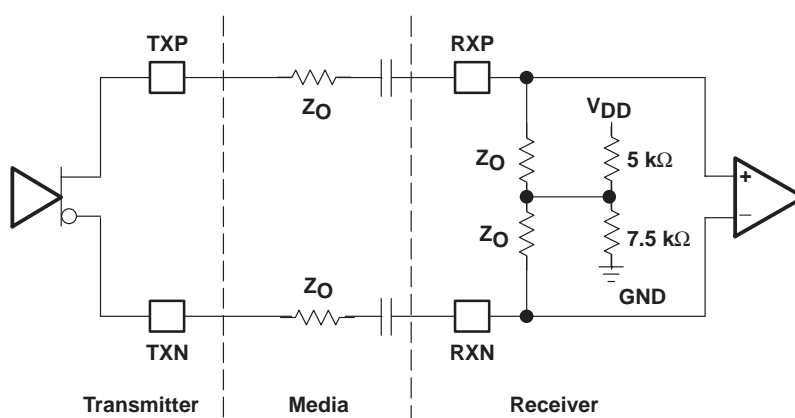

Figure 12. High-Speed I/O AC-Coupled Mode

AC-coupling is only recommended if the parallel TX data stream is encoded to achieve a dc-balanced data stream. Otherwise, the ac-caps can induce common-mode voltage drift due to the dc-unbalanced data stream.

designing with PowerPAD

The TLK2521 is housed in a high-performance, thermally enhanced, 64-pin HTQFP (PAP64) PowerPAD package. Use of the PowerPAD package does not require any special considerations except to note that the PowerPAD, which is an exposed die pad on the bottom of the device, is a metallic thermal and electrical conductor. Therefore, if not implementing PowerPAD PCB features, the use of solder masks (or other assembly techniques) may be required to prevent any inadvertent shorting by the exposed PowerPAD of connection etches or vias under the package. **It is strongly recommended that the PowerPAD be soldered to the thermal land.** The recommended convention, however, is to not run any etches or signal vias under the device, but to have only a grounded thermal land as explained below. Although the actual size of the exposed die pad may vary, the minimum size required for the keep out area for the 64-pin PAP PowerPAD package is 8 mm x 8 mm.

It is recommended that there be a thermal land, which is an area of solder-tinned-copper, underneath the PowerPAD package. The thermal land varies in size depending on the PowerPAD package being used, the PCB construction, and the amount of heat that needs to be removed. In addition, the thermal land may or may not contain numerous thermal vias depending on PCB construction.

Other requirements for thermal lands and thermal vias are detailed in the TI application note *PowerPAD™ Thermally Enhanced Package* application report, TI (SLMA002), available via the TI Web pages beginning at URL: <http://www.ti.com>.

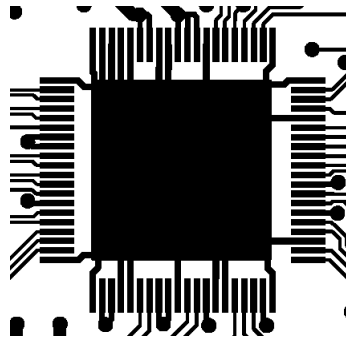

Figure 13. Example of a Thermal Land

For the TLK2521, this thermal land should be grounded to the low-impedance ground plane of the device. This improves not only thermal performance but also the electrical grounding of the device. It is also recommended that the device ground pin landing pads be connected directly to the grounded thermal land. The land size should be as large as possible without shorting device signal pins. The thermal land may be soldered to the exposed PowerPAD using standard reflow soldering techniques.

While the thermal land may be electrically floated and configured to remove heat to an external heat sink, it is recommended that the thermal land be connected to the low impedance ground plane for the device. More information may be obtained from the TI application note *PHY Layout*, TI (SLLA020).

PACKAGING INFORMATION

Orderable Device	Status (1)	Package Type	Package Drawing	Pins	Package Qty	Eco Plan (2)	Lead/Ball Finish (6)	MSL Peak Temp (3)	Op Temp (°C)	Device Marking (4/5)	Samples
TLK2521IPAP	LIFEBUY	HTQFP	PAP	64	160	Green (RoHS & no Sb/Br)	CU NIPDAU	Level-3-260C-168 HR	-40 to 85	TLK2521	
TLK2521IPAPG4	LIFEBUY	HTQFP	PAP	64	160	Green (RoHS & no Sb/Br)	CU NIPDAU	Level-3-260C-168 HR	-40 to 85	TLK2521	

(1) The marketing status values are defined as follows:

ACTIVE: Product device recommended for new designs.

LIFEBUY: TI has announced that the device will be discontinued, and a lifetime-buy period is in effect.

NRND: Not recommended for new designs. Device is in production to support existing customers, but TI does not recommend using this part in a new design.

PREVIEW: Device has been announced but is not in production. Samples may or may not be available.

OBSOLETE: TI has discontinued the production of the device.

(2) Eco Plan - The planned eco-friendly classification: Pb-Free (RoHS), Pb-Free (RoHS Exempt), or Green (RoHS & no Sb/Br) - please check <http://www.ti.com/productcontent> for the latest availability information and additional product content details.

TBD: The Pb-Free/Green conversion plan has not been defined.

Pb-Free (RoHS): TI's terms "Lead-Free" or "Pb-Free" mean semiconductor products that are compatible with the current RoHS requirements for all 6 substances, including the requirement that lead not exceed 0.1% by weight in homogeneous materials. Where designed to be soldered at high temperatures, TI Pb-Free products are suitable for use in specified lead-free processes.

Pb-Free (RoHS Exempt): This component has a RoHS exemption for either 1) lead-based flip-chip solder bumps used between the die and package, or 2) lead-based die adhesive used between the die and leadframe. The component is otherwise considered Pb-Free (RoHS compatible) as defined above.

Green (RoHS & no Sb/Br): TI defines "Green" to mean Pb-Free (RoHS compatible), and free of Bromine (Br) and Antimony (Sb) based flame retardants (Br or Sb do not exceed 0.1% by weight in homogeneous material)

(3) MSL, Peak Temp. - The Moisture Sensitivity Level rating according to the JEDEC industry standard classifications, and peak solder temperature.

(4) There may be additional marking, which relates to the logo, the lot trace code information, or the environmental category on the device.

(5) Multiple Device Markings will be inside parentheses. Only one Device Marking contained in parentheses and separated by a "~" will appear on a device. If a line is indented then it is a continuation of the previous line and the two combined represent the entire Device Marking for that device.

(6) Lead/Ball Finish - Orderable Devices may have multiple material finish options. Finish options are separated by a vertical ruled line. Lead/Ball Finish values may wrap to two lines if the finish value exceeds the maximum column width.

Important Information and Disclaimer: The information provided on this page represents TI's knowledge and belief as of the date that it is provided. TI bases its knowledge and belief on information provided by third parties, and makes no representation or warranty as to the accuracy of such information. Efforts are underway to better integrate information from third parties. TI has taken and continues to take reasonable steps to provide representative and accurate information but may not have conducted destructive testing or chemical analysis on incoming materials and chemicals. TI and TI suppliers consider certain information to be proprietary, and thus CAS numbers and other limited information may not be available for release.

In no event shall TI's liability arising out of such information exceed the total purchase price of the TI part(s) at issue in this document sold by TI to Customer on an annual basis.

PAP (S-PQFP-G64)

PowerPAD™ PLASTIC QUAD FLATPACK

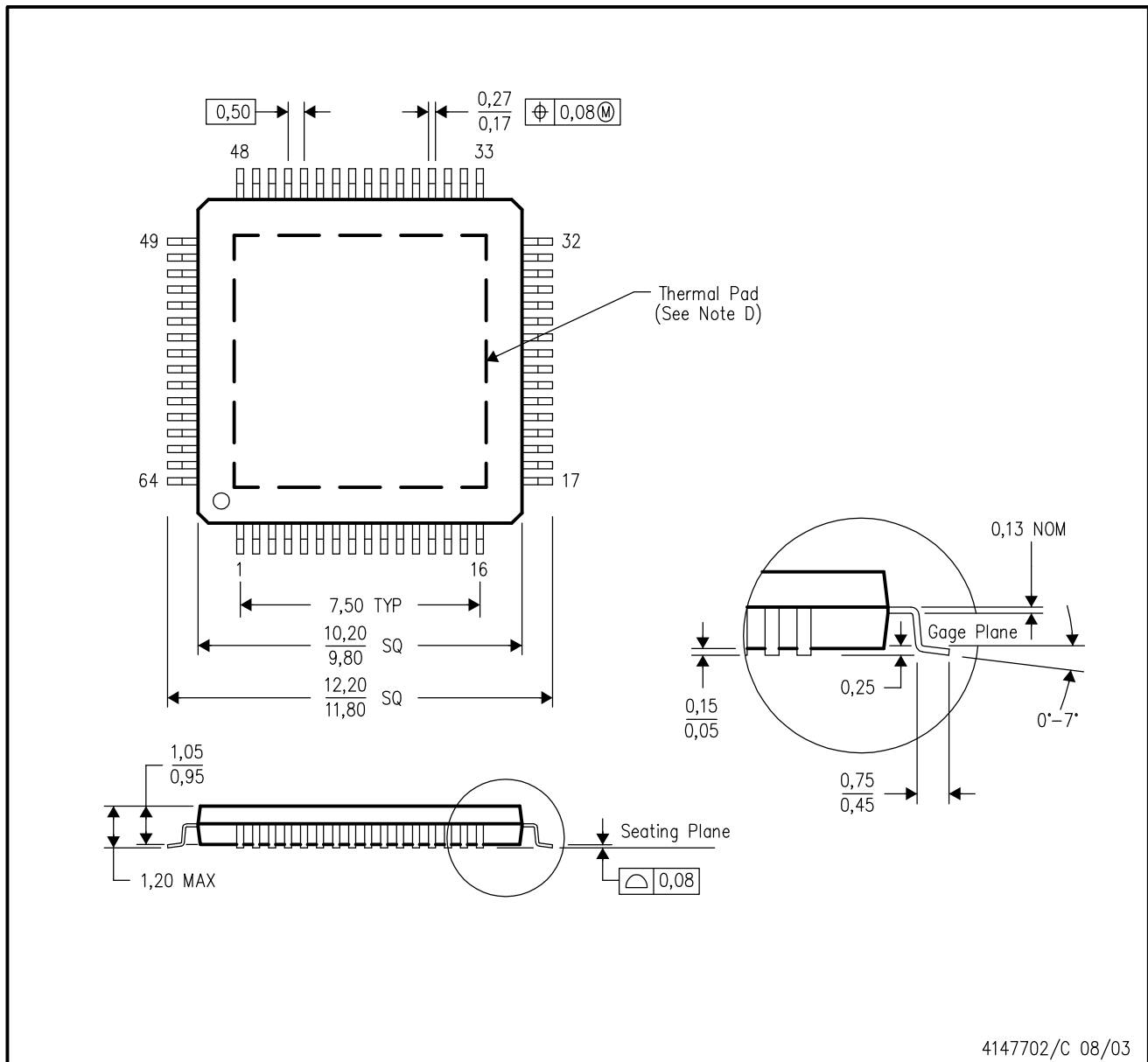

- NOTES:
- A. All linear dimensions are in millimeters.
 - B. This drawing is subject to change without notice.
 - C. Body dimensions do not include mold flash or protrusion
 - D. This package is designed to be soldered to a thermal pad on the board. Refer to Technical Brief, PowerPad Thermally Enhanced Package, Texas Instruments Literature No. SLMA002 for information regarding recommended board layout. This document is available at www.ti.com <<http://www.ti.com>>.
 - E. Falls within JEDEC MS-026

PowerPAD is a trademark of Texas Instruments.

THERMAL PAD MECHANICAL DATA

PAP (S-PQFP-G64)

PowerPAD™ PLASTIC QUAD FLATPACK

THERMAL INFORMATION

This PowerPAD™ package incorporates an exposed thermal pad that is designed to be attached to a printed circuit board (PCB). The thermal pad must be soldered directly to the PCB. After soldering, the PCB can be used as a heatsink. In addition, through the use of thermal vias, the thermal pad can be attached directly to the appropriate copper plane shown in the electrical schematic for the device, or alternatively, can be attached to a special heatsink structure designed into the PCB. This design optimizes the heat transfer from the integrated circuit (IC).

For additional information on the PowerPAD package and how to take advantage of its heat dissipating abilities, refer to Technical Brief, PowerPAD Thermally Enhanced Package, Texas Instruments Literature No. SLMA002 and Application Brief, PowerPAD Made Easy, Texas Instruments Literature No. SLMA004. Both documents are available at www.ti.com.

The exposed thermal pad dimensions for this package are shown in the following illustration.

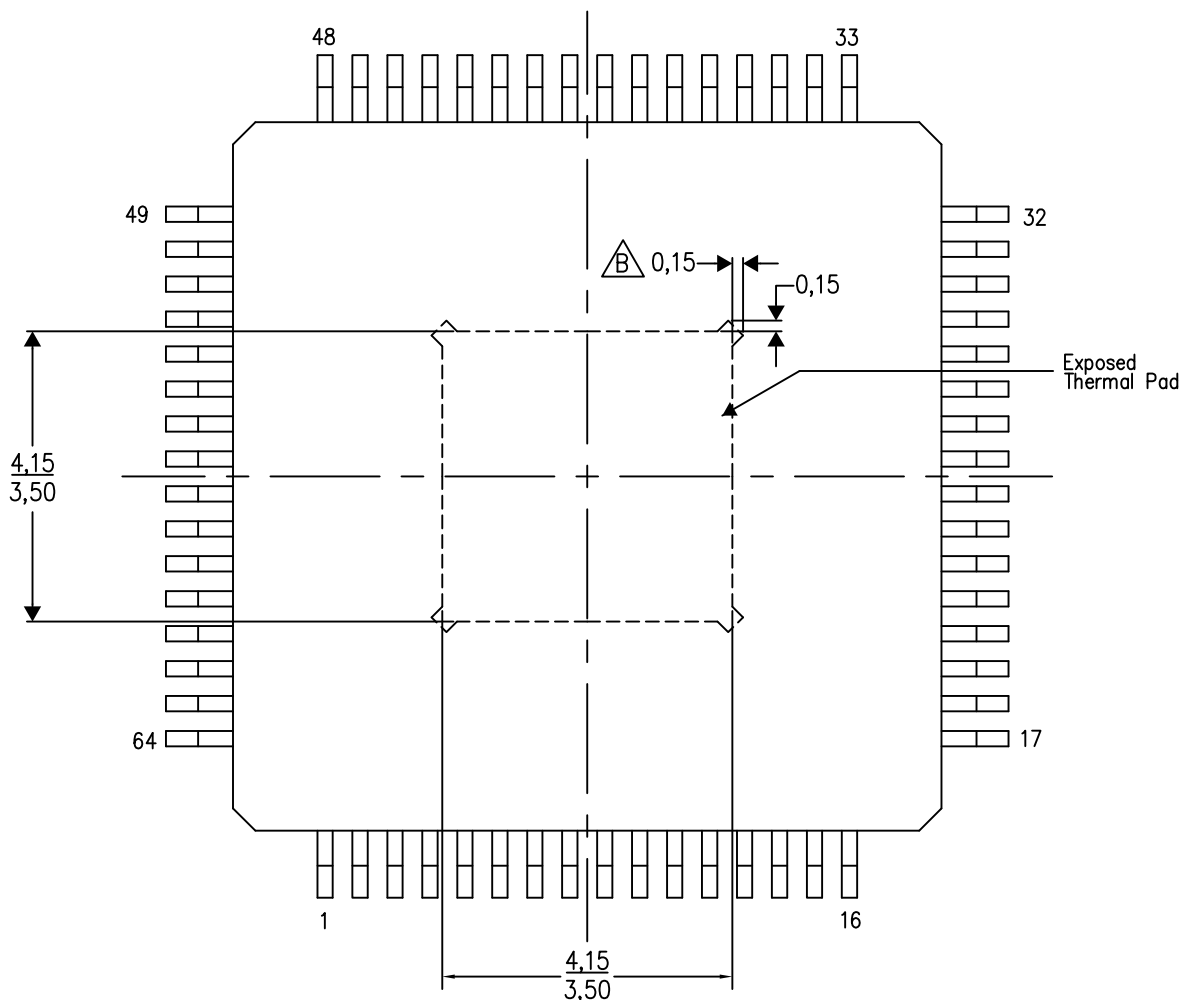

4206326-2/P 05/14

NOTES: A. All linear dimensions are in millimeters

 Tie strap features may not be present.

PowerPAD is a trademark of Texas Instruments

LAND PATTERN DATA

PAP (S-PQFP-G64)

PowerPAD™ PLASTIC QUAD FLATPACK

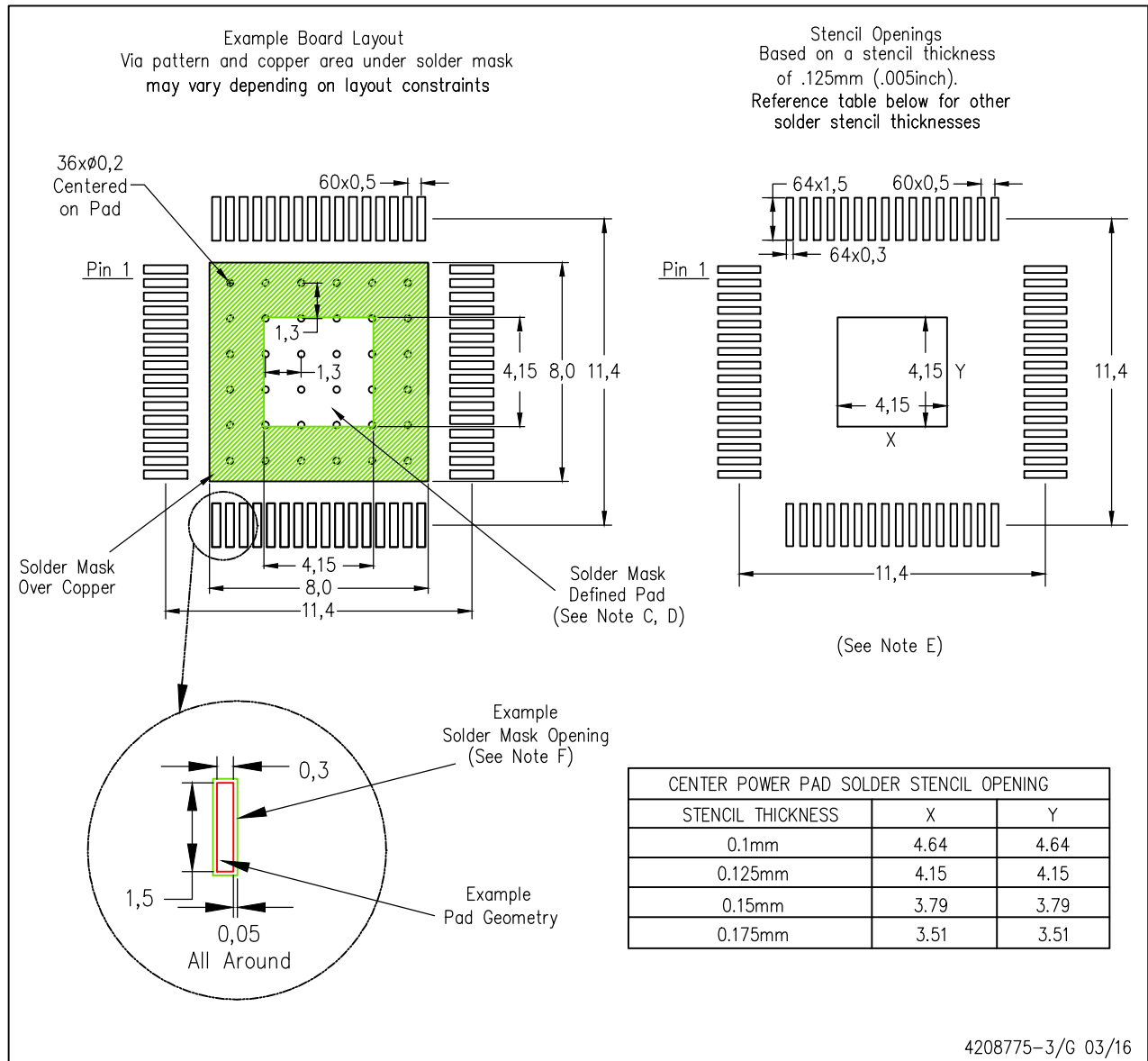

- NOTES:
- A. All linear dimensions are in millimeters.
 - B. This drawing is subject to change without notice.
 - C. Customers should place a note on the circuit board fabrication drawing not to alter the center solder mask defined pad.
 - D. This package is designed to be soldered to a thermal pad on the board. Refer to Technical Brief, PowerPad Thermally Enhanced Package, Texas Instruments Literature No. SLMA002, SLMA004, and also the Product Data Sheets for specific thermal information, via requirements, and recommended board layout. These documents are available at www.ti.com <<http://www.ti.com>>. Publication IPC-7351 is recommended for alternate designs.
 - E. Laser cutting apertures with trapezoidal walls and also rounding corners will offer better paste release. Customers should contact their board assembly site for stencil design recommendations. Example stencil design based on a 50% volumetric metal load solder paste. Refer to IPC-7525 for other stencil recommendations.
 - F. Customers should contact their board fabrication site for solder mask tolerances between and around signal pads.
- PowerPAD is a trademark of Texas Instruments**

IMPORTANT NOTICE FOR TI DESIGN INFORMATION AND RESOURCES

Texas Instruments Incorporated ("TI") technical, application or other design advice, services or information, including, but not limited to, reference designs and materials relating to evaluation modules, (collectively, "TI Resources") are intended to assist designers who are developing applications that incorporate TI products; by downloading, accessing or using any particular TI Resource in any way, you (individually or, if you are acting on behalf of a company, your company) agree to use it solely for this purpose and subject to the terms of this Notice.

TI's provision of TI Resources does not expand or otherwise alter TI's applicable published warranties or warranty disclaimers for TI products, and no additional obligations or liabilities arise from TI providing such TI Resources. TI reserves the right to make corrections, enhancements, improvements and other changes to its TI Resources.

You understand and agree that you remain responsible for using your independent analysis, evaluation and judgment in designing your applications and that you have full and exclusive responsibility to assure the safety of your applications and compliance of your applications (and of all TI products used in or for your applications) with all applicable regulations, laws and other applicable requirements. You represent that, with respect to your applications, you have all the necessary expertise to create and implement safeguards that (1) anticipate dangerous consequences of failures, (2) monitor failures and their consequences, and (3) lessen the likelihood of failures that might cause harm and take appropriate actions. You agree that prior to using or distributing any applications that include TI products, you will thoroughly test such applications and the functionality of such TI products as used in such applications. TI has not conducted any testing other than that specifically described in the published documentation for a particular TI Resource.

You are authorized to use, copy and modify any individual TI Resource only in connection with the development of applications that include the TI product(s) identified in such TI Resource. NO OTHER LICENSE, EXPRESS OR IMPLIED, BY ESTOPPEL OR OTHERWISE TO ANY OTHER TI INTELLECTUAL PROPERTY RIGHT, AND NO LICENSE TO ANY TECHNOLOGY OR INTELLECTUAL PROPERTY RIGHT OF TI OR ANY THIRD PARTY IS GRANTED HEREIN, including but not limited to any patent right, copyright, mask work right, or other intellectual property right relating to any combination, machine, or process in which TI products or services are used. Information regarding or referencing third-party products or services does not constitute a license to use such products or services, or a warranty or endorsement thereof. Use of TI Resources may require a license from a third party under the patents or other intellectual property of the third party, or a license from TI under the patents or other intellectual property of TI.

TI RESOURCES ARE PROVIDED "AS IS" AND WITH ALL FAULTS. TI DISCLAIMS ALL OTHER WARRANTIES OR REPRESENTATIONS, EXPRESS OR IMPLIED, REGARDING TI RESOURCES OR USE THEREOF, INCLUDING BUT NOT LIMITED TO ACCURACY OR COMPLETENESS, TITLE, ANY EPIDEMIC FAILURE WARRANTY AND ANY IMPLIED WARRANTIES OF MERCHANTABILITY, FITNESS FOR A PARTICULAR PURPOSE, AND NON-INFRINGEMENT OF ANY THIRD PARTY INTELLECTUAL PROPERTY RIGHTS.

TI SHALL NOT BE LIABLE FOR AND SHALL NOT DEFEND OR INDEMNIFY YOU AGAINST ANY CLAIM, INCLUDING BUT NOT LIMITED TO ANY INFRINGEMENT CLAIM THAT RELATES TO OR IS BASED ON ANY COMBINATION OF PRODUCTS EVEN IF DESCRIBED IN TI RESOURCES OR OTHERWISE. IN NO EVENT SHALL TI BE LIABLE FOR ANY ACTUAL, DIRECT, SPECIAL, COLLATERAL, INDIRECT, PUNITIVE, INCIDENTAL, CONSEQUENTIAL OR EXEMPLARY DAMAGES IN CONNECTION WITH OR ARISING OUT OF TI RESOURCES OR USE THEREOF, AND REGARDLESS OF WHETHER TI HAS BEEN ADVISED OF THE POSSIBILITY OF SUCH DAMAGES.

You agree to fully indemnify TI and its representatives against any damages, costs, losses, and/or liabilities arising out of your non-compliance with the terms and provisions of this Notice.

This Notice applies to TI Resources. Additional terms apply to the use and purchase of certain types of materials, TI products and services. These include; without limitation, TI's standard terms for semiconductor products (<http://www.ti.com/sc/docs/stdterms.htm>), [evaluation modules](#), and [samples](http://www.ti.com/sc/docs/sampterm.htm) (<http://www.ti.com/sc/docs/sampterm.htm>).

Mailing Address: Texas Instruments, Post Office Box 655303, Dallas, Texas 75265
Copyright © 2017, Texas Instruments Incorporated

Looking for pricing, stock, or lifecycle information?

Click below to explore more details on WIN SOURCE:

 [View TLK2521IPAPG4 on WIN SOURCE](#)

 [Texas Instruments](#) Information

Optimize Your Supply Chain with WIN SOURCE Solutions

-  Global Sourcing Solution
-  Obsolete Management
-  Cost Control Management
-  Shortage Management
-  Alternative Solution
-  Excess Inventory Management