



**THE DATASHEET OF
84021BYLF**



Functional Description

NOTE: The functional description that follows describes operation using a 25MHz crystal. Valid PLL loop divider values for different crystal or input frequencies are defined in the Input Frequency Characteristics, Table 5, NOTE 1.

The 84021 features a fully integrated PLL and therefore requires no external components for setting the loop bandwidth. A fundamental crystal is used as the input to the on-chip oscillator. The output of the oscillator is fed into the phase detector. A 25MHz crystal provides a 25MHz phase detector reference frequency. The VCO of the PLL operates over a range of 620MHz to 780MHz. The output of the M divider is also applied to the phase detector.

The phase detector and the M divider force the VCO output frequency to be M times the reference frequency by adjusting the VCO control voltage. Note that for some values of M (either too high or too low), the PLL will not achieve lock. The output of the VCO is scaled by a divider prior to being sent to each of the LVCMOS output buffers. The divider provides a 50% output duty cycle.

The programmable features of the 84021 support two input modes to program the M divider and N output divider. The two input operational modes are parallel and serial. Figure 1 shows the timing diagram for each mode. In parallel mode, the nP_LOAD input is initially LOW. The data on inputs M0 through M8 and N0 and N1 is passed directly to the M divider and N output divider. On the LOW-to-HIGH transition of the nP_LOAD input, the data is latched and the M divider remains loaded until the next LOW transition on nP_LOAD or until a serial event occurs. As a result, the M and N bits can be hardwired to set the M divider and N output divider to a specific default state that will automatically occur during power-up. The TEST output is LOW when operating in the parallel input mode. The relationship between the

VCO frequency, the crystal frequency and the M divider is defined as follows: $f_{VCO} = f_{xtal} \times M$

The M value and the required values of M0 through M8 are shown in Table 3B, Programmable VCO Frequency Function Table. Valid M values for which the PLL will achieve lock for a 25MHz reference are defined as $25 \leq M \leq 31$. The frequency out is defined as follows:

$$F_{OUT} = \frac{f_{VCO}}{N} = \frac{f_{xtal} \times M}{N}$$

Serial operation occurs when nP_LOAD is HIGH and S_LOAD is LOW. The shift register is loaded by sampling the S_DATA bits with the rising edge of S_CLOCK. The contents of the shift register are loaded into the M divider and N output divider when S_LOAD transitions from LOW-to-HIGH. The M divide and N output divide values are latched on the HIGH-to-LOW transition of S_LOAD. If S_LOAD is held HIGH, data at the S_DATA input is passed directly to the M divider and N output divider on each rising edge of S_CLOCK. The serial mode can be used to program the M and N bits and test bits T1 and T0. The internal registers T0 and T1 determine the state of the TEST output as follows:

T1	T0	TEST Output
0	0	LOW
0	1	S_DATA, Shift Register Input
1	0	Output of M Divider
1	1	CMOS FOUT

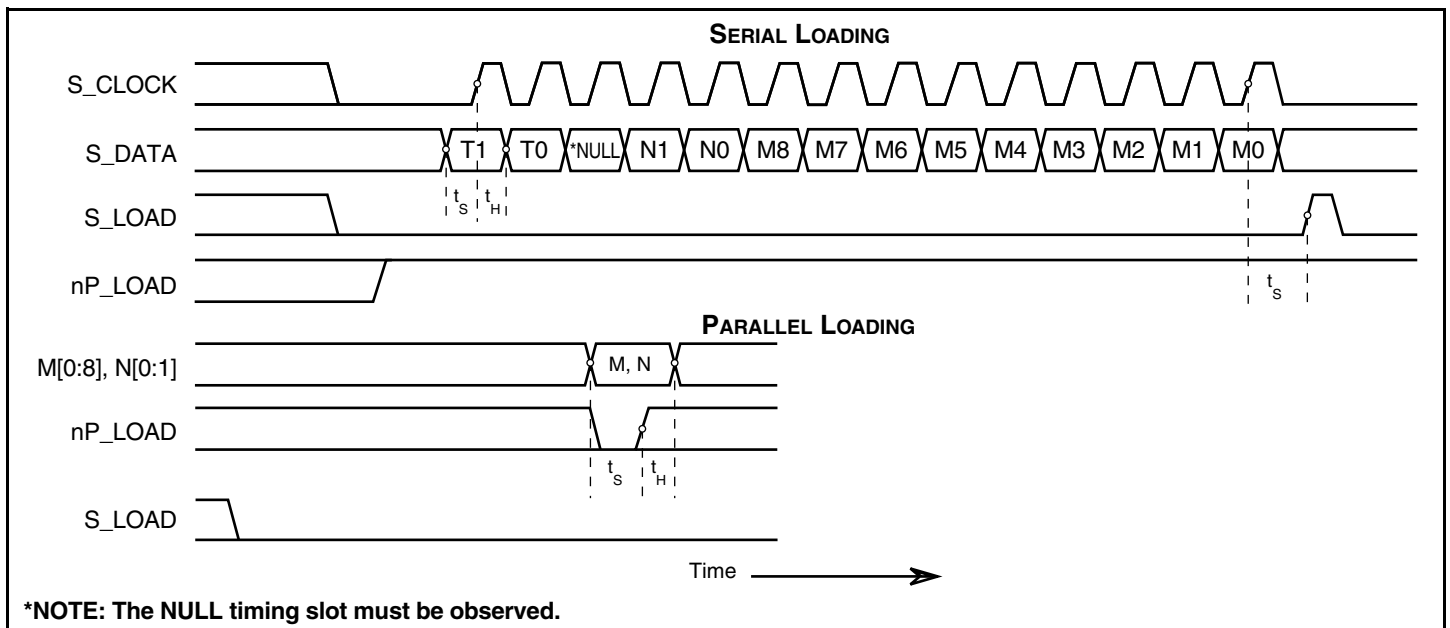

Figure 1. Parallel & Serial Load Operations

Table 1. Pin Descriptions

Number	Name	Type		Description
1	M5	Input	Pullup	M divider inputs. Data latched on LOW-to-HIGH transition of nP_LOAD input. LVCMOS/LVTTL interface levels.
2, 3, 4, 28, 29, 30, 31, 32	M6, M7, M8, M0, M1, M2, M3, M4	Input	Pulldown	
5, 6	N0, N1	Input	Pulldown	Determines N output divider value as defined in Table 3C, Function Table. LVCMOS/LVTTL interface levels.
7	nc	Unused		No connect.
8, 16	GND	Power		Power supply pins.
9	TEST	Output		Test output which is ACTIVE in the serial mode of operation. Output driven LOW in parallel mode. LVCMOS/LVTTL interface levels.
10	V _{DD}	Power		Core supply pin.
11, 12	OE1, OE0	Input	Pullup	Output enable. When logic HIGH, the outputs are enabled (default). When logic LOW, the outputs are in an Hi-Z state. See Table 3E, OE Function Table. LVCMOS/LVTTL interface levels.
13	V _{DDO}	Power		Output supply pin.
14, 15	Q1, Q0	Output		Single-ended clock outputs. LVCMOS/LVTTL interface levels.
17	MR	Input	Pulldown	Active High Master Reset. When logic HIGH, the internal dividers are reset causing the outputs to go low. When Logic LOW, the internal dividers and the outputs are enabled. Assertion of MR does not affect loaded M, N, and T values. LVCMOS/LVTTL interface levels.
18	S_CLOCK	Input	Pulldown	Clocks in serial data present at S_DATA input into the shift register on the rising edge of S_CLOCK. LVCMOS/LVTTL interface levels.
19	S_DATA	Input	Pulldown	Shift register serial input. Data sampled on the rising edge of S_CLOCK. LVCMOS/LVTTL interface levels.
20	S_LOAD	Input	Pulldown	Controls transition of data from shift register into the dividers. LVCMOS/LVTTL interface levels.
21	V _{DDA}	Power		Analog supply pin.
22	XTAL_SEL	Input	Pullup	Selects between crystal or test inputs as the PLL reference source. Selects XTAL inputs when HIGH. Selects TEST_CLK when LOW. LVCMOS/LVTTL interface levels.
23	TEST_CLK	Input	Pulldown	Single-ended test clock input. LVCMOS/LVTTL interface levels.
24, 25	XTAL_OUT XTAL_IN	Input		Crystal oscillator interface. XTAL_IN is the input, XTAL_OUT is the output.
26	nP_LOAD	Input	Pulldown	Parallel load input. Determines when data present at M[8:0] is loaded into M divider, and when data present at N[1:0] sets the N output divider value. LVCMOS/LVTTL interface levels.
27	VCO_SEL	Input	Pullup	Determines whether synthesizer is in PLL or bypass mode. LVCMOS/LVTTL interface levels.

NOTE: Pullup and Pulldown refer to internal input resistors. See Table 2, Pin Characteristics, for typical values.

Table 2. Pin Characteristics

Symbol	Parameter	Test Conditions	Minimum	Typical	Maximum	Units
C_{IN}	Input Capacitance			4		pF
C_{PD}	Power Dissipation Capacitance (per output)	$V_{DDO} = 3.465V$		15		pF
		$V_{DDO} = 2.625V$		15		pF
		$V_{DDO} = 1.89V$		20		pF
R_{PULLUP}	Input Pullup Resistor			51		k Ω
$R_{PULLDOWN}$	Input Pulldown Resistor			51		k Ω
R_{OUT}	Output Impedance	$V_{DDO} = 3.3V \pm 5\%$		7		Ω
		$V_{DDO} = 2.5V \pm 5\%$		7		Ω
		$V_{DDO} = 1.8V \pm 5\%$		10		Ω

Function Tables**Table 3A. Parallel and Serial Mode Function Table**

Inputs							Conditions
MR	nP_LOAD	M	N	S_LOAD	S_CLOCK	S_DATA	
H	X	X	X	X	X	X	Reset. Forces outputs LOW.
L	L	Data	Data	X	X	X	Data on M and N inputs passed directly to the M divider and N output divider. TEST output forced LOW.
L	↑	Data	Data	L	X	X	Data is latched into input registers and remains loaded until next LOW transition or until a serial event occurs.
L	H	X	X	L	↑	Data	Serial input mode. Shift register is loaded with data on S_DATA on each rising edge of S_CLOCK.
L	H	X	X	↑	L	Data	Contents of the shift register are passed to the M divider and N output divider.
L	H	X	X	↓	L	Data	M divider and N output divider values are latched.
L	H	X	X	L	X	X	Parallel or serial input do not affect shift registers.
L	H	X	X	H	↑	Data	S_DATA passed directly to M divider as it is clocked.

NOTE: L = LOW
H = HIGH
X = Don't care
↑ = Rising edge transition
↓ = Falling edge transition

Table 3B. Programmable VCO Frequency Function Table^(NOTE 1)

VCO Frequency (MHz)	M Divide	256	128	64	32	16	8	4	2	1
		M8	M7	M6	M5	M4	M3	M2	M1	M0
625	25	0	0	0	0	1	1	0	0	1
•	•	•	•	•	•	•	•	•	•	•
700	28	0	0	0	0	1	1	1	0	0
•	•	•	•	•	•	•	•	•	•	•
775	31	0	0	0	0	1	1	1	1	1

NOTE 1: These M divide values and the resulting frequencies correspond to TEST_CLK or crystal frequency of 25MHz.

Table 3C. Programmable Output Divider Function Table (PLL Enabled)

Inputs		N Divider Value	Output Frequency (MHz)	
N1	N0		Minimum	Maximum
0	0	3	206.7	260
0	1	4	155	195
1	0	5	124	156
1	1	6	103.3	130

Table 3D. Commonly Used Configuration Function Table

Inputs			Output Frequency (MHz)
Crystal (MHz)	M Divider Value	N Divider Value	Minimum
19.44	32	4	155.52
19.53125	32	4	156.25
25	25	4	156.25
25	25	5	125
25.50	25	3	212.50
25.50	25	4	159.375
25.50	25	6	106.25
38.88	16	4	155.52

Table 3E. Output Enable & Clock Enable Function Table

Control Inputs		Output	
OE0	OE1	Q0	Q1
0	0	Hi-Z	Hi-Z
0	1	Hi-Z	Enabled
1	0	Enabled	Hi-Z
1	1	Enabled	Enabled

Absolute Maximum Ratings

NOTE: Stresses beyond those listed under *Absolute Maximum Ratings* may cause permanent damage to the device.

These ratings are stress specifications only. Functional operation of product at these conditions or any conditions beyond those listed in the *DC Characteristics* or *AC Characteristics* is not implied. Exposure to absolute maximum rating conditions for extended periods may affect product reliability.

Item	Rating
Supply Voltage, V_{DD}	4.6V
Inputs, V_I XTAL_IN Other Inputs	0V to V_{DD} -0.5V to $V_{DD} + 0.5V$
Outputs, V_O	-0.5V to $V_{DDO} + 0.5V$
Package Thermal Impedance, θ_{JA}	47.9°C/W (0 lfpm)
Storage Temperature, T_{STG}	-65°C to 150°C

DC Electrical Characteristics

Table 4A. Power Supply DC Characteristics, $V_{DD} = 3.3V \pm 5\%$, $V_{DDO} = 3.3V \pm 5\%$, $2.5V \pm 5\%$ or $1.8V \pm 5\%$, $T_A = 0^\circ\text{C}$ to 70°C

Symbol	Parameter	Test Conditions	Minimum	Typical	Maximum	Units
V_{DD}	Core Supply Voltage		3.135	3.3	3.465	V
V_{DDA}	Analog Supply Voltage		$V_{DD} - 0.36$	3.3	V_{DD}	V
V_{DDO}	Output Supply Voltage		3.135	3.3	3.465	V
			2.375	2.5	2.625	V
			1.71	1.8	1.89	V
I_{DD}	Power Supply Current				110	mA
I_{DDA}	Analog Supply Current				24	mA
I_{DDO}	Output Supply Current				5	mA

Table 4B. LVCMOS/LVTTL DC Characteristics, $V_{DD} = 3.3V \pm 5\%$, $V_{DDO} = 3.3V \pm 5\%$, $2.5V \pm 5\%$ or $1.8V \pm 5\%$, $T_A = 0^\circ\text{C}$ to 70°C

Symbol	Parameter		Test Conditions	Minimum	Typical	Maximum	Units
V_{IH}	Input High Voltage			2		$V_{DD} + 0.3$	V
V_{IL}	Input Low Voltage	OE[0:1], N[0:1], M[0:8], XTAL_SEL, VCO_SEL, S_DATA, S_CLOCK, S_LOAD, nP_LOAD, MR		-0.3		0.8	V
		TEST_CLOCK		-0.3		1.3	V
I_{IH}	Input High Current	MR, S_CLOCK, TEST_CLK, S_DATA, S_LOAD, nP_LOAD, M[0:4], M[6:8], N0, N1	$V_{DD} = V_{IN} = 3.465V$			150	μA
		M5, OE0, OE1, XTAL_SEL, VCO_SEL	$V_{DD} = V_{IN} = 3.465V$			5	μA
I_{IL}	Input Low Current	MR, S_CLOCK, TEST_CLK, S_DATA, S_LOAD, nP_LOAD, M[0:4], M[6:8], N0, N1	$V_{DD} = 3.465V, V_{IN} = 0V$	-5			μA
		M5, OE0, OE1, XTAL_SEL, VCO_SEL	$V_{DD} = 3.465V, V_{IN} = 0V$	-150			μA
V_{OH}	Output High Voltage; NOTE 1		$V_{DDO} = 3.3V \pm 5\%$	2.6			V
			$V_{DDO} = 2.5V \pm 5\%$	1.8			V
			$V_{DDO} = 1.8V \pm 5\%$	$V_{DDO} - 0.3$			V
V_{OL}	Output Low Voltage; NOTE 1		$V_{DDO} = 3.3V \pm 5\%$ or $2.5V \pm 5\%$			0.5	V
			$V_{DDO} = 1.8V \pm 5\%$			0.4	V

NOTE 1: Outputs terminated with 50Ω to $V_{DDO}/2$. See Parameter Measurement Information section, *Output Load Test Circuit diagrams*.

Table 5. Input Frequency Characteristics, $V_{DD} = 3.3V \pm 5\%$, $V_{DDO} = 3.3V \pm 5\%$, $2.5V \pm 5\%$ or $1.8V \pm 5\%$, $T_A = 0^\circ\text{C}$ to 70°C

Symbol	Parameter		Test Conditions	Minimum	Typical	Maximum	Units
f_{IN}	Input Frequency	TEST_CLK; NOTE 1		14		40	MHz
		XTAL; NOTE 1		14		40	MHz
		S_CLOCK				50	MHz

NOTE 1: For the input crystal and TEST_CLK frequency range, the M value must be set for the VCO to operate within the 620MHz to 780MHz range. Using the minimum input frequency of 14MHz, valid values of M are $45 \leq M \leq 55$. Using the maximum input frequency of 40MHz, valid values of M are $16 \leq M \leq 19$.

Table 6. Crystal Characteristics

Parameter	Test Conditions	Minimum	Typical	Maximum	Units
Mode of Oscillation		Fundamental			
Frequency		14		40	MHz
Equivalent Series Resistance (ESR)				50	Ω
Shunt Capacitance (C_O)				7	pF

AC Electrical Characteristics

Table 7A. AC Characteristics, $V_{DD} = V_{DDO} = 3.3V \pm 5\%$, $T_A = 0^\circ\text{C}$ to 70°C

Symbol	Parameter	Test Conditions	Minimum	Typical	Maximum	Units
f_{OUT}	Output Frequency		103.3		260	MHz
$f_{jit(per)}$	Period Jitter, RMS; NOTE 1, 2	N = 3		13.5	26.4	ps
		N = 4		14.7	34.2	ps
		N = 5		16.7	42.4	ps
		N = 6		24.7	40.8	ps
		M=40, N=4, 16.667MHz XTAL, $f_{OUT}=166.67\text{MHz}$		4.5	6.9	ps
		M=40, N=5, 16.667MHz XTAL, $f_{OUT}=133.33\text{MHz}$		4.6	7.8	ps
$t_{sk(o)}$	Output Skew; NOTE 2, 3				100	ps
t_R / t_F	Output Rise/Fall Time	20% to 80%	100		800	ps
t_S	Setup Time	M, N to nP_LOAD		5		ns
		S_DATA to S_CLOCK		5		ns
		S_CLOCK to S_LOAD		5		ns
t_H	Hold Time	M, N to nP_LOAD		5		ns
		S_DATA to S_CLOCK		5		ns
		S_CLOCK to S_LOAD		5		ns
odc	Output Duty Cycle	N \neq 3		44	56	%
		M=40, N=4, 16.667MHz XTAL, $f_{OUT}=166.67\text{MHz}$		45	55	%
		M=40, N=5, 16.667MHz XTAL, $f_{OUT}=133.33\text{MHz}$		47	53	%
t_{LOCK}	PLL Lock Time				1	ms

NOTE: Electrical parameters are guaranteed over the specified ambient operating temperature range, which is established when the device is mounted in a test socket with maintained transverse airflow greater than 500 lpm. The device will meet specifications after thermal equilibrium has been reached under these conditions.

NOTE 1: Jitter performance using XTAL inputs.

NOTE 2: This parameter is defined in accordance with JEDEC Standard 65.

NOTE 3: Defined as skew between outputs at the same supply voltage and with equal load conditions. Measured at $V_{DDO}/2$.

Table 7B. AC Characteristics, $V_{DD} = 3.3V \pm 5\%$, $V_{DDO} = 2.5V \pm 5\%$, $T_A = 0^\circ C$ to $70^\circ C$

Symbol	Parameter	Test Conditions	Minimum	Typical	Maximum	Units
f_{OUT}	Output Frequency		103.3		260	MHz
$f_{jit(per)}$	Period Jitter, RMS; NOTE 1, 2	N = 3		11.4	18.8	ps
		N = 4		13.3	28.3	ps
		N = 5		16.0	39.8	ps
		N = 6		19.2	32.4	ps
		M=40, N=4, 16.667MHz XTAL, $f_{OUT}=166.67MHz$		4.3	6.2	ps
		M=40, N=5, 16.667MHz XTAL, $f_{OUT}=133.33MHz$		4.5	7.7	ps
$t_{sk(o)}$	Output Skew; NOTE 2, 3				90	ps
t_R / t_F	Output Rise/Fall Time	20% to 80%	100		800	ps
t_S	Setup Time	M, N to nP_LOAD		5		ns
		S_DATA to S_CLOCK		5		ns
		S_CLOCK to S_LOAD		5		ns
t_H	Hold Time	M, N to nP_LOAD		5		ns
		S_DATA to S_CLOCK		5		ns
		S_CLOCK to S_LOAD		5		ns
odc	Output Duty Cycle	N \neq 3		44	56	%
		M=40, N=4, 16.667MHz XTAL, $f_{OUT}=166.67MHz$		45	55	%
		M=40, N=5, 16.667MHz XTAL, $f_{OUT}=133.33MHz$		47	53	%
t_{LOCK}	PLL Lock Time				1	ms

NOTE: Electrical parameters are guaranteed over the specified ambient operating temperature range, which is established when the device is mounted in a test socket with maintained transverse airflow greater than 500 lpm. The device will meet specifications after thermal equilibrium has been reached under these conditions.

NOTE 1: Jitter performance using XTAL inputs.

NOTE 2: This parameter is defined in accordance with JEDEC Standard 65.

NOTE 3: Defined as skew between outputs at the same supply voltage and with equal load conditions. Measured at $V_{DDO}/2$.

Table 7C. AC Characteristics, $V_{DD} = 3.3V \pm 5\%$, $V_{DDO} = 1.8V \pm 5\%$, $T_A = 0^\circ C$ to $70^\circ C$

Symbol	Parameter	Test Conditions	Minimum	Typical	Maximum	Units
f_{OUT}	Output Frequency		103.3		260	MHz
$f_{jit(per)}$	Period Jitter, RMS; NOTE 1, 2	N = 3		9.4	13.2	ps
		N = 4		10.8	19.6	ps
		N = 5		12.7	32.5	ps
		N = 6		13.4	25.4	ps
		M=40, N=4, 16.667MHz XTAL, $f_{OUT}=166.67MHz$		5.4	8.3	ps
		M=40, N=5, 16.667MHz XTAL, $f_{OUT}=133.33MHz$		5.1	8.8	ps
$t_{sk(o)}$	Output Skew; NOTE 2, 3				90	ps
t_R / t_F	Output Rise/Fall Time	20% to 80%	100		800	ps
t_S	Setup Time	M, N to nP_LOAD		5		ns
		S_DATA to S_CLOCK		5		ns
		S_CLOCK to S_LOAD		5		ns
t_H	Hold Time	M, N to nP_LOAD		5		ns
		S_DATA to S_CLOCK		5		ns
		S_CLOCK to S_LOAD		5		ns
odc	Output Duty Cycle	N \neq 3	40		60	%
		M=40, N=4, 16.667MHz XTAL, $f_{OUT}=166.67MHz$	44		56	%
		M=40, N=5, 16.667MHz XTAL, $f_{OUT}=133.33MHz$	48		52	%
t_{LOCK}	PLL Lock Time				1	ms

NOTE: Electrical parameters are guaranteed over the specified ambient operating temperature range, which is established when the device is mounted in a test socket with maintained transverse airflow greater than 500 lpm. The device will meet specifications after thermal equilibrium has been reached under these conditions.

NOTE 1: Jitter performance using XTAL inputs.

NOTE 2: This parameter is defined in accordance with JEDEC Standard 65.

NOTE 3: Defined as skew between outputs at the same supply voltage and with equal load conditions. Measured at $V_{DDO}/2$.

Parameter Measurement Information

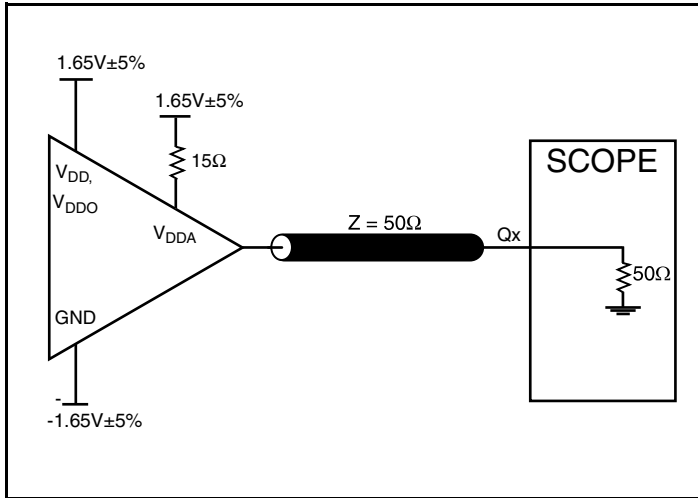

3.3V Core/3.3V Output Load AC Test Circuit

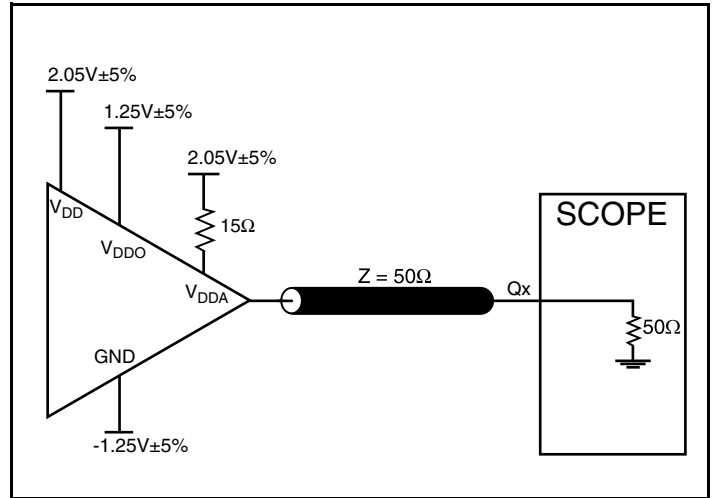

3.3V Core/2.5V Output Load AC Test Circuit

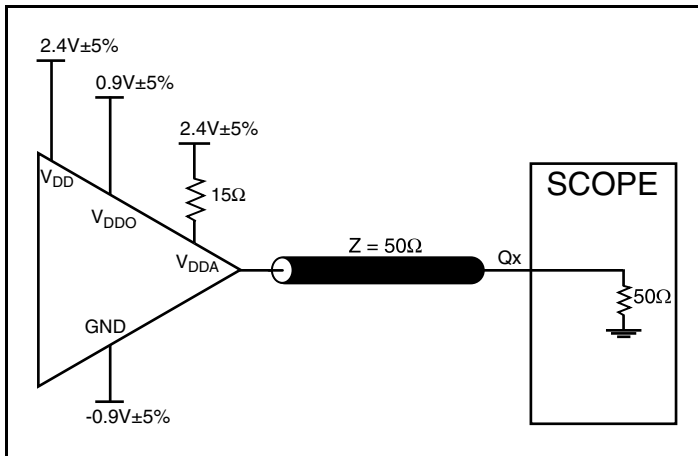

3.3V Core/1.8V Output Load AC Test Circuit

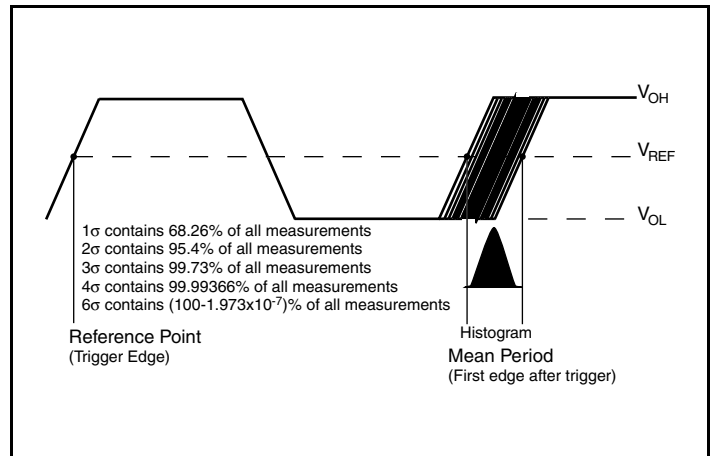

Period Jitter

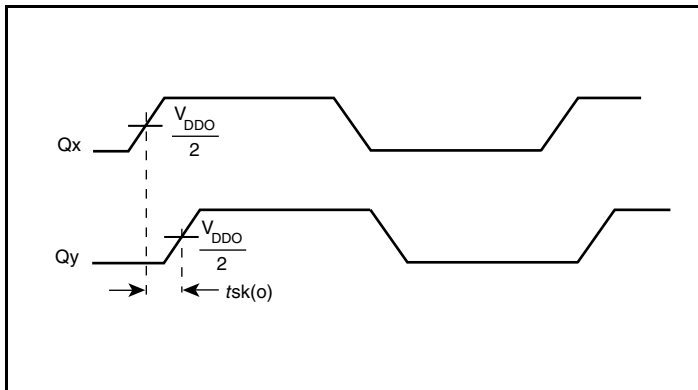

Output Skew

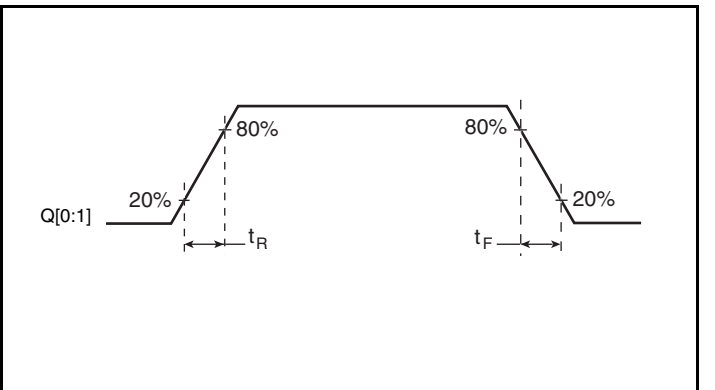

Output Rise/Fall Time

Parameter Measurement Information, continued

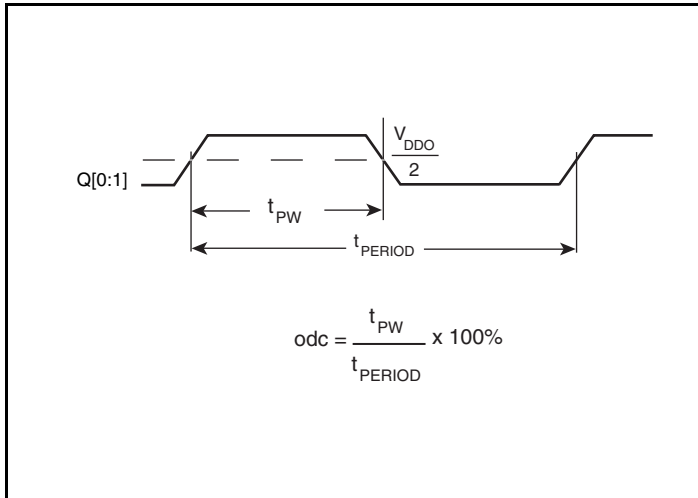

Output Duty Cycle/Pulse Width/Period

Applications Information

Recommendations for Unused Input and Output Pins

Inputs:

Crystal Inputs

For applications not requiring the use of the crystal oscillator input, both XTAL_IN and XTAL_OUT can be left floating. Though not required, but for additional protection, a 1k Ω resistor can be tied from XTAL_IN to ground.

TEST_CLK Input

For applications not requiring the use of the test clock, it can be left floating. Though not required, but for additional protection, a 1k Ω resistor can be tied from the TEST_CLK to ground.

LVCMOS Control Pins

All control pins have internal pullups or pulldowns; additional resistance is not required but can be added for additional protection. A 1k Ω resistor can be used.

Outputs:

TEST Output

The unused TEST output can be left floating. There should be no trace attached.

LVCMOS Outputs

All unused LVCMOS outputs can be left floating. We recommend that there is no trace attached.

Overdriving the XTAL Interface

The XTAL_IN input can accept a single-ended LVCMOS signal through an AC coupling capacitor. A general interface diagram is shown in *Figure 2A*. The XTAL_OUT pin can be left floating. The maximum amplitude of the input signal should not exceed 2V and the input edge rate can be as slow as 10ns. This configuration requires that the output impedance of the driver (R_o) plus the series resistance (R_s) equals the transmission line impedance. In addition,

matched termination at the crystal input will attenuate the signal in half. This can be done in one of two ways. First, R_1 and R_2 in parallel should equal the transmission line impedance. For most 50 Ω applications, R_1 and R_2 can be 100 Ω . This can also be accomplished by removing R_1 and making R_2 50 Ω . By overdriving the crystal oscillator, the device will be functional, but note, the device performance is guaranteed by using a quartz crystal.

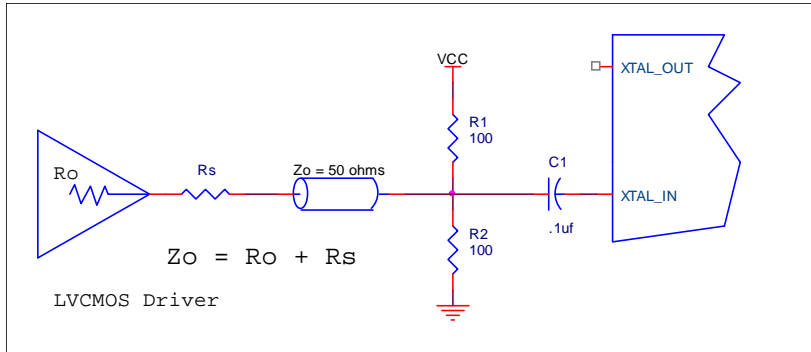

Figure 2A. General Diagram for LVCMOS Driver to XTAL Input Interface

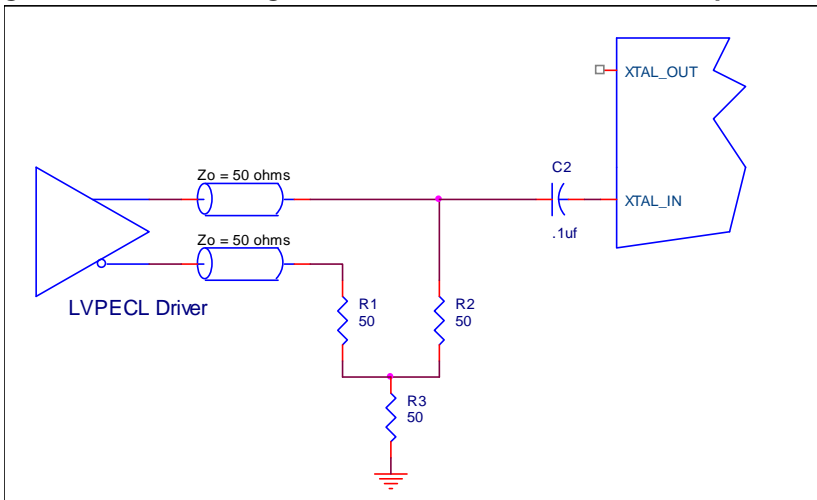

Figure 2B. General Diagram for LVPECL Driver to XTAL Input Interface

Layout Guideline

Figure 3 shows a schematic example of the 84021. In this example, a series termination is shown. Additional LVCMOS termination approaches are shown in the LVCMOS Termination Application Note. In this example, an 18pF parallel resonant crystal is used. The C1 = 22pF and C2 = 22pF are approximate values for frequency accuracy. The C1 and C2 may be slightly adjusted for optimizing frequency accuracy.

As with any high speed analog circuitry, the power supply pins are vulnerable to noise. To achieve optimum jitter performance, power supply isolation is required. The 84021 provides separate power supplies to isolate from coupling into the internal PLL.

In order to achieve the best possible filtering, it is recommended that the placement of the filter components be on the device side of the PCB as close to the power pins as possible. If space is limited, the 0.1uF capacitor in each power pin filter should be placed on the

device side of the PCB and the other components can be placed on the opposite side.

Power supply filter recommendations are a general guideline to be used for reducing external noise from coupling into the devices. The filter performance is designed for wide range of noise frequencies. This low-pass filter starts to attenuate noise at approximately 10kHz. If a specific frequency noise component is known, such as switching power supply frequencies, it is recommended that component values be adjusted and if required, additional filtering be added. Additionally, good general design practices for power plane voltage stability suggests adding bulk capacitances in the local area of all devices.

The schematic example focuses on functional connections and is not configuration specific. Refer to the pin description and functional tables in the datasheet to ensure the logic control inputs are properly set.

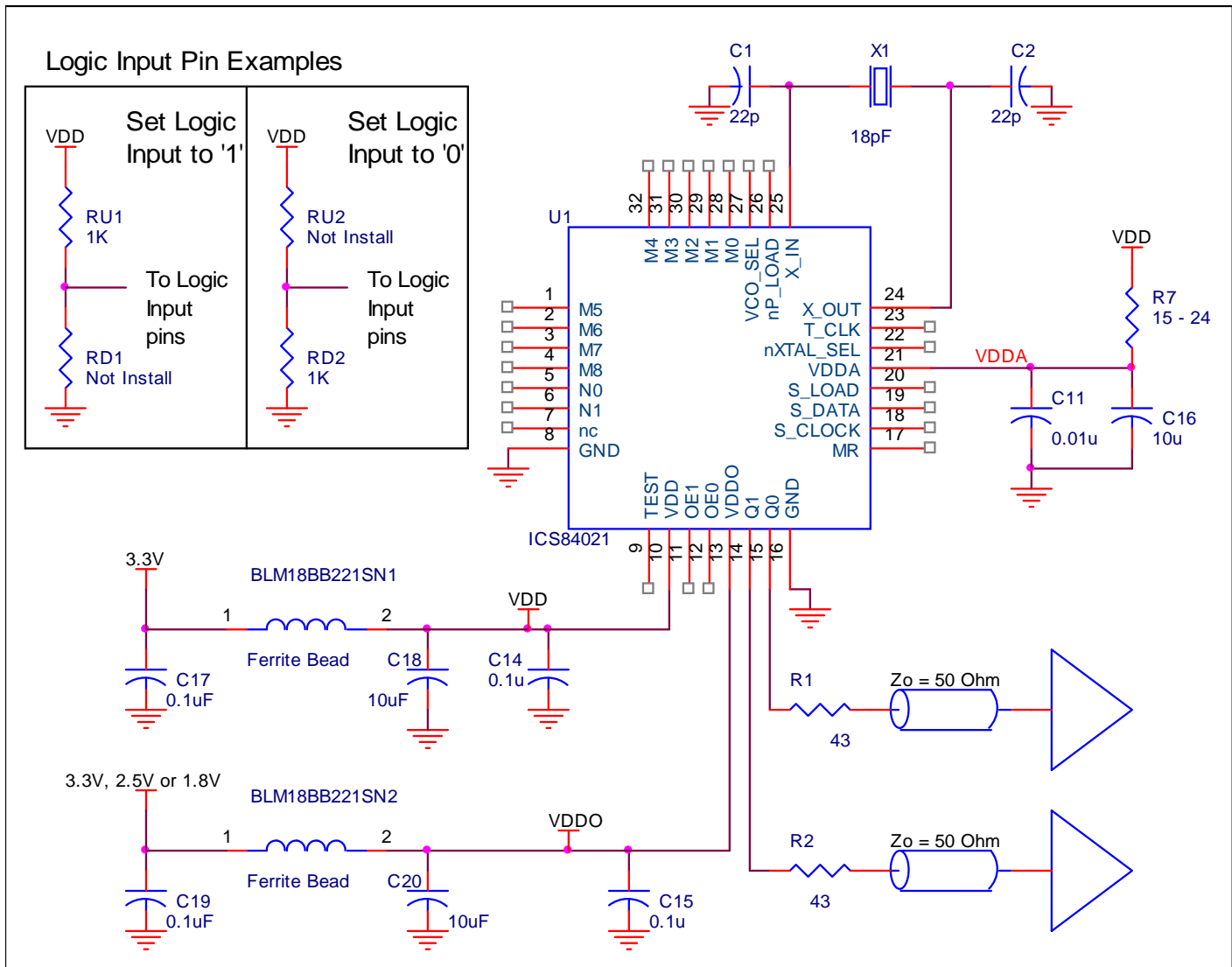

Figure 3. 84021 Application Schematic Example

Reliability Information

Table 8. θ_{JA} vs. Air Flow Table for a 32 Lead LQFP

θ_{JA} by Velocity			
Linear Feet per Minut	0	1	2.5
Single-Layer PCB, JEDEC Standard Test Boards	67.8°C/W	55.9°C/W	50.1°C/W
Multi-Layer PCB, JEDEC Standard Test Boards	47.9°C/W	42.1°C/W	39.4°C/W

Transistor Count

The transistor count for 84021 is: 4325

Package Outline and Package Dimensions

Package Outline - Y Suffix for 32 Lead LQFP

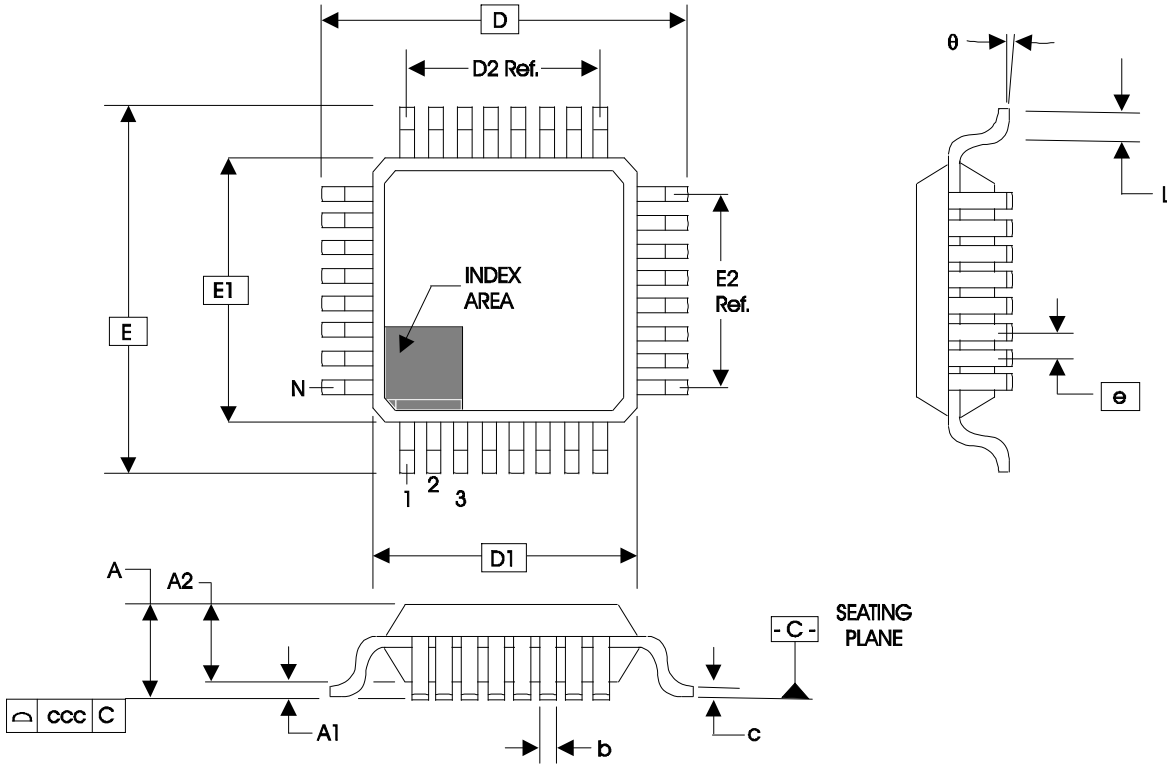

Table 9. Package Dimensions for 32 Lead LQFP

JEDEC Variation: BBC - HD			
All Dimensions in Millimeters			
Symbol	Minimum	Nominal	Maximum
N	32		
A			1.60
A1	0.05	0.10	0.15
A2	1.35	1.40	1.45
b	0.30	0.37	0.45
c	0.09		0.20
D & E	9.00 Basic		
D1 & E1	7.00 Basic		
D2 & E2	5.60 Ref.		
e	0.80 Basic		
L	0.45	0.60	0.75
θ	0°		7°
ccc			0.10

Reference Document: JEDEC Publication 95, MS-026

Ordering Information

Table 10. Ordering Information

Part/Order Number	Marking	Package	Shipping Packaging	Temperature
84021BYLF	ICS84021BYLF	"Lead-Free" 32 Lead LQFP	Tray	0°C to 70°C
84021BYLFT	ICS84021BYLF	"Lead-Free" 32 Lead LQFP	1000 Tape & Reel	0°C to 70°C

NOTE: Parts that are ordered with an "LF" suffix to the part number are the Pb-Free configuration and are RoHS compliant.

While the information presented herein has been checked for both accuracy and reliability, Integrated Device Technology (IDT) assumes no responsibility for either its use or for the infringement of any patents or other rights of third parties, which would result from its use. No other circuits, patents, or licenses are implied. This product is intended for use in normal commercial applications. Any other applications, such as those requiring extended temperature ranges, high reliability or other extraordinary environmental requirements are not recommended without additional processing by IDT. IDT reserves the right to change any circuitry or specifications without notice. IDT does not authorize or warrant any IDT product for use in life support devices or critical medical instruments.

Revision History Sheet

Rev	Table	Page	Description of Change	Date
B	T2	4 12	Pin Characteristics Table - added R_{OUT} rows. Added Schematic Layout. Changed XTAL naming convention to XTAL_IN/XTAL_OUT throughout the data sheet.	1/5/04
C	T6 T10	1 2 7 15	Features Section - added Lead-Free bullet. Updated Parallel & Serial Load Operations Diagram. Crystal Characteristics Table - added Drive Level. Ordering Information Table - added Lead-Free package.	6/9/05
D	T4A T6 T7A - T7C T10	1 6 6 7 8 - 10 11 12 13 13 14 17	Features section - updated RMS period jitter spec in bullet; added RMS phase jitter bullet. Block Diagram - added pullups/pulldowns to input pins and added "N" in output divider box. Absolute Maximum Ratings - updated Inputs, V_I . Power Supply DC Characteristics - updated V_{DDA} , I_{DD} , I_{DDA} and I_{DDO} specs. Crystal Characteristics - deleted Drive Level row. Updated Period Jitter, Output Rise/Fall Time and Output Duty Cycle specs. Added thermal note. Parameter Measurement Information - corrected Output Load AC Test Circuit diagrams to coincide with $15\Omega V_{DDA}$. Added Recommendations for Unused Input & Output Pins. Deleted Power Supply Filtering Techniques section, added to schematic layout. Added Overdriving the XTAL Interface section. Updated Layout Guideline and diagram. Ordering Information Table - updated Part/Order Numbers and Marking to revision "B". Converted datasheet format.	1/5/11
E	T7A	8 13	AC Characteristics Table - corrected Period Jitter N = 4 spec, from 32.2ps max. to 34.2ps max. Deleted Crystal Input Interface section, added to the schematic.	8/18/11
E	T10	17	Ordering Information - removed leaded device.	9/23/15



Corporate Headquarters
6024 Silver Creek Valley Road
San Jose, CA 95138 USA

Sales
1-800-345-7015 or 408-284-8200
Fax: 408-284-2775
www.IDT.com

Tech Support
email: clocks@idt.com

DISCLAIMER Integrated Device Technology, Inc. (IDT) and its subsidiaries reserve the right to modify the products and/or specifications described herein at any time and at IDT's sole discretion. All information in this document, including descriptions of product features and performance, is subject to change without notice. Performance specifications and the operating parameters of the described products are determined in the independent state and are not guaranteed to perform the same way when installed in customer products. The information contained herein is provided without representation or warranty of any kind, whether express or implied, including, but not limited to, the suitability of IDT's products for any particular purpose, an implied warranty of merchantability, or non-infringement of the intellectual property rights of others. This document is presented only as a guide and does not convey any license under intellectual property rights of IDT or any third parties.

IDT's products are not intended for use in applications involving extreme environmental conditions or in life support systems or similar devices where the failure or malfunction of an IDT product can be reasonably expected to significantly affect the health or safety of users. Anyone using an IDT product in such a manner does so at their own risk, absent an express, written agreement by IDT.

While the information presented herein has been checked for both accuracy and reliability, Integrated Device Technology (IDT) assumes no responsibility for either its use or for the infringement of any patents or other rights of third parties, which would result from its use. No other circuits, patents, or licenses are implied. This product is intended for use in normal commercial applications. Any other applications, such as those requiring extended temperature ranges, high reliability or other extraordinary environmental requirements are not recommended without additional processing by IDT. IDT reserves the right to change any circuitry or specifications without notice. IDT does not authorize or warrant any IDT product for use in life support devices or critical medical instruments.

Integrated Device Technology, IDT and the IDT logo are registered trademarks of IDT. Product specification subject to change without notice. Other trademarks and service marks used herein, including protected names, logos and designs, are the property of IDT or their respective third party owners.

Copyright ©2015 Integrated Device Technology, Inc.. All rights reserved.

Looking for pricing, stock, or lifecycle information?

Click below to explore more details on WIN SOURCE:

-  [View 84021BYLF on WIN SOURCE](#)
-  [Renesas Electronics America](#) Information

Optimize Your Supply Chain with WIN SOURCE Solutions

-  Global Sourcing Solution
-  Obsolete Management
-  Cost Control Management
-  Shortage Management
-  Alternative Solution
-  Excess Inventory Management