



**THE DATASHEET OF  
CS5205A-1GDPR3**



# CS5205A-1



## 5.0 A Adjustable Linear Regulator

The CS5205A-1 linear regulator provides 5.0 A at an adjustable voltage with an accuracy of  $\pm 1\%$ . Two external resistors are used to set the output voltage within a 1.25 V to 13 V range.

The regulator is intended for use as a post regulator and microprocessor supply. The fast loop response and low dropout voltage make this regulator ideal for applications where low voltage operation and good transient response are important.

The circuit is designed to operate with dropout voltages as low as 1.0 V depending on the output current level. The maximum quiescent current is only 10 mA at full load.

The regulator is fully protected against overload conditions with protection circuitry for Safe Operating Area (SOA), overcurrent and thermal shutdown.

The CS5205A-1 is pin compatible with the LT1084 family of linear regulators but has lower dropout voltage.

The regulator is available in TO-220-3 and surface mount D<sup>2</sup>PAK-3 packages.

**ON Semiconductor**<sup>®</sup>

<http://onsemi.com>

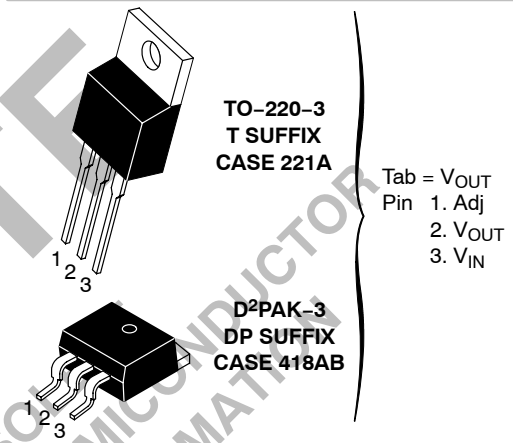

### Features

- Output Current to 5.0 A
- Output Trimmed to  $\pm 1\%$
- Dropout Voltage 1.15 V @ 5.0 A
- Fast Transient Response
- Fault Protection Circuitry
  - Thermal Shutdown
  - Overcurrent Protection
  - Safe Area Protection

### MARKING DIAGRAMS

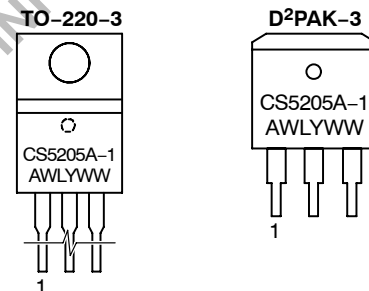

A = Assembly Location  
WL, L = Wafer Lot  
YY, Y = Year  
WW, W = Work Week

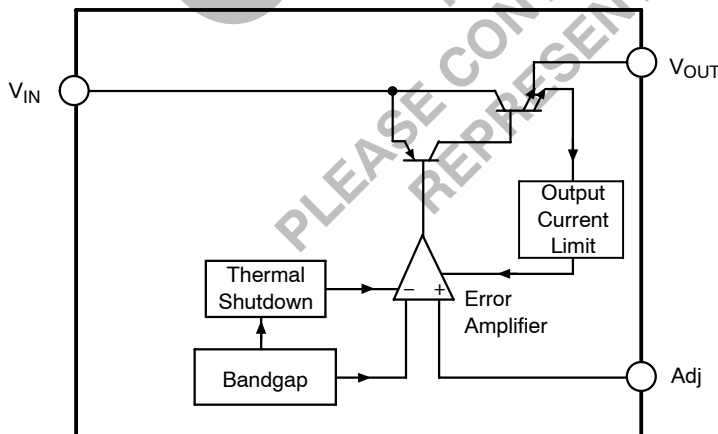

Figure 1. Block Diagram

### ORDERING INFORMATION

See detailed ordering and shipping information in the package dimensions section on page 6 of this data sheet.

# CS5205A-1

## MAXIMUM RATINGS\*

Parameter	Value	Unit	
Supply Voltage, $V_{CC}$	17	V	
Operating Temperature Range	-40 to +70	°C	
Junction Temperature	150	°C	
Storage Temperature Range	-60 to +150	°C	
Lead Temperature Soldering:	Wave Solder (through hole styles only) Note 1 Reflow (SMD styles only) Note 2	260 Peak 230 Peak	°C

- 10 second maximum.
- 60 second maximum above 183°C.

\*The maximum package power dissipation must be observed.

**ELECTRICAL CHARACTERISTICS** ( $C_{IN} = 10 \mu\text{F}$ ,  $C_{OUT} = 22 \mu\text{F}$  Tantalum,  $V_{IN} - V_{OUT} = 3.0 \text{ V}$ ,  $V_{IN} \leq 15 \text{ V}$ ,  $0^\circ\text{C} \leq T_A \leq 70^\circ\text{C}$ ,  $T_J \leq +150^\circ\text{C}$ , unless otherwise specified,  $I_{full load} = 5.0 \text{ A}$ )

Characteristic	Test Conditions	Min	Typ	Max	Unit
<b>Adjustable Output Voltage</b>					
Reference Voltage (Notes 3 and 4)	$V_{IN} - V_{OUT} = 1.5 \text{ V}$ ; $V_{Adj} = 0 \text{ V}$ , $10 \text{ mA} \leq I_{OUT} \leq 5.0 \text{ A}$	1.241 (-1%)	1.254	1.266 (+1%)	V
Line Regulation	$1.5 \text{ V} \leq V_{IN} - V_{OUT} \leq 6.0 \text{ V}$ ; $I_{OUT} = 10 \text{ mA}$	-	0.04	0.20	%
Load Regulation (Notes 3 and 4)	$V_{IN} - V_{OUT} = 1.5 \text{ V}$ ; $10 \text{ mA} \leq I_{OUT} \leq 5.0 \text{ A}$	-	0.08	0.4	%
Dropout Voltage (Note 5)	$I_{OUT} = 5.0 \text{ A}$ ; $T_J \geq 25^\circ\text{C}$	-	1.15	1.25	V
Current Limit	$V_{IN} - V_{OUT} = 3.0 \text{ V}$ ; $T_J \geq 25^\circ\text{C}$ $V_{IN} - V_{OUT} = 9.0 \text{ V}$	5.5	8.5	-	A
		-	1.0	-	A
Minimum Load Current	$V_{IN} - V_{OUT} = 7.0 \text{ V}$	-	1.2	6.0	mA
Adjust Pin Current		-	50	100	$\mu\text{A}$
Adjust Pin Current Change	$1.5 \text{ V} \leq V_{IN} - V_{OUT} \leq 4.0 \text{ V}$ ; $10 \text{ mA} \leq I_{OUT} \leq 5.0 \text{ A}$	-	0.2	5.0	$\mu\text{A}$
Thermal Regulation	30 ms pulse; $T_A = 25^\circ\text{C}$	-	0.003	-	%W
Ripple Rejection	$f = 120 \text{ Hz}$ ; $C_{Adj} = 25 \mu\text{F}$ ; $I_{OUT} = 5.0 \text{ A}$	-	82	-	dB
Temperature Stability	-	-	0.5	-	%
RMS Output Noise	$10 \text{ Hz} \leq f \leq 10 \text{ kHz}$ ; $T_A = 25^\circ\text{C}$	-	0.003	-	% $V_{OUT}$
Thermal Shutdown	-	150	180	-	°C
Thermal Shutdown Hysteresis	-	-	25	-	°C

- Load regulation and output voltage are measured at a constant junction temperature by low duty cycle pulse testing. Changes in output voltage due to thermal gradients or temperature changes must be taken into account separately.
- Specifications apply for an external Kelvin sense connection at a point on the output pin 1/4" from the bottom of the package.
- Dropout voltage is a measurement of the minimum input/output differential at full load.

## PACKAGE PIN DESCRIPTION

Package Pin Number		Pin Symbol	Function
TO-220-3	D <sup>2</sup> PAK-3		
1	1	Adj	Adjust pin (low side of the internal reference).
2	2	$V_{OUT}$	Regulated output voltage (case).
3	3	$V_{IN}$	Input voltage.

TYPICAL PERFORMANCE CHARACTERISTICS

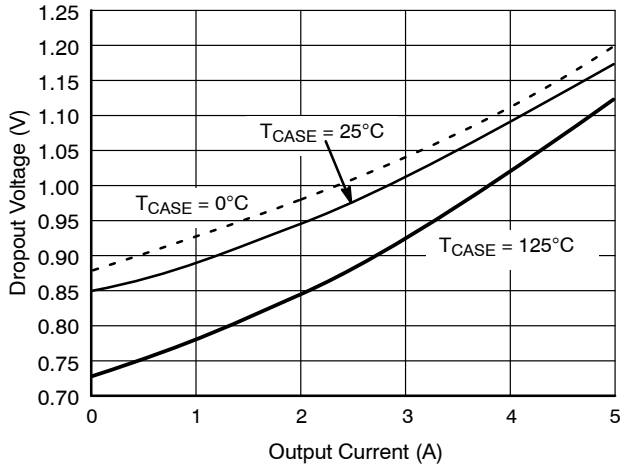

Figure 2. Dropout Voltage vs. Output Current

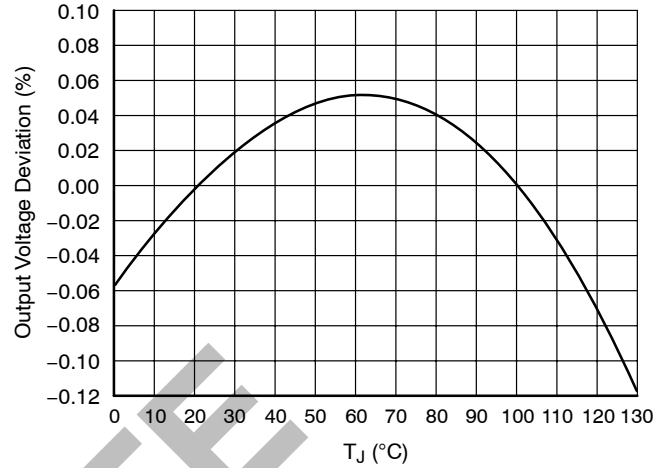

Figure 3. Reference Voltage vs. Temperature

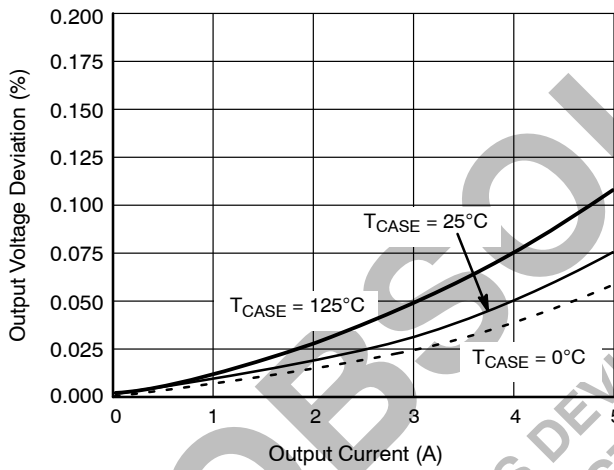

Figure 4. Load Regulation vs. Output Current

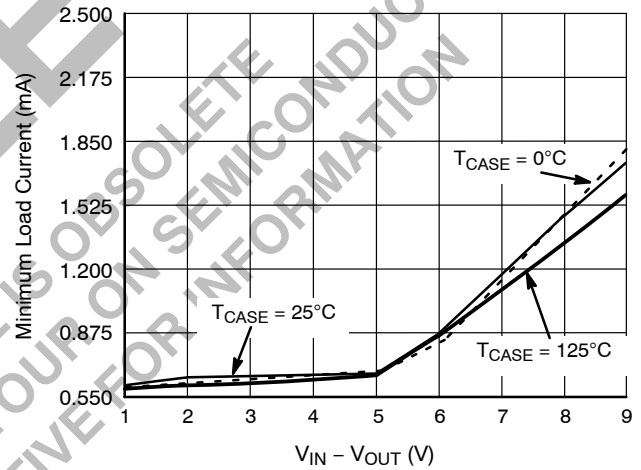

Figure 5. Minimum Load Current

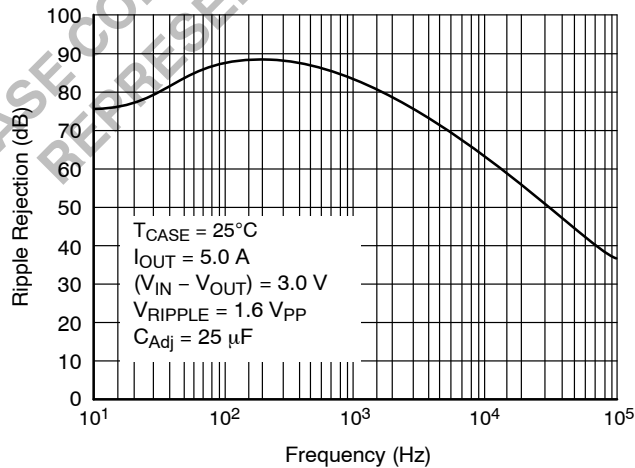

Figure 6. Ripple Rejection vs. Frequency

## APPLICATIONS INFORMATION

The CS5205A-1 linear regulator provides an adjustable voltage at currents up to 5.0 A. The regulator is protected against short circuit, and include thermal shutdown and safe area protection (SOA) circuitry. The SOA protection circuitry decreases the maximum available output current as the input-output differential voltage increases.

The CS5205A-1 has a composite PNP-NPN output transistor and requires an output capacitor for stability. A detailed procedure for selecting this capacitor is included in the Stability Considerations section.

**Adjustable Operation**

The adjustable regulator (CS5205A-1) has an output voltage range of 1.25 V to 13 V. An external resistor divider sets the output voltage as shown in Figure 7. The regulator maintains a fixed 1.25 V (typical) reference between the output pin and the adjust pin.

A resistor divider network R1 and R2 causes a fixed current to flow to ground. This current creates a voltage across R2 that adds to the 1.25 V across R1 and sets the overall output voltage. The adjust pin current (typically 50  $\mu$ A) also flows through R2 and adds a small error that should be taken into account if precise adjustment of V<sub>OUT</sub> is necessary.

The output voltage is set according to the formula:

$$V_{OUT} = V_{REF} \times \left( \frac{R_1 + R_2}{R_1} \right) + I_{Adj} \times R_2$$

The term  $I_{Adj} \times R_2$  represents the error added by the adjust pin current.

R1 is chosen so that the minimum load current is at least 10 mA. R1 and R2 should be the same type, e.g. metal film for best tracking over temperature. The adjust pin is bypassed to improve the transient response and ripple rejection of the regulator.

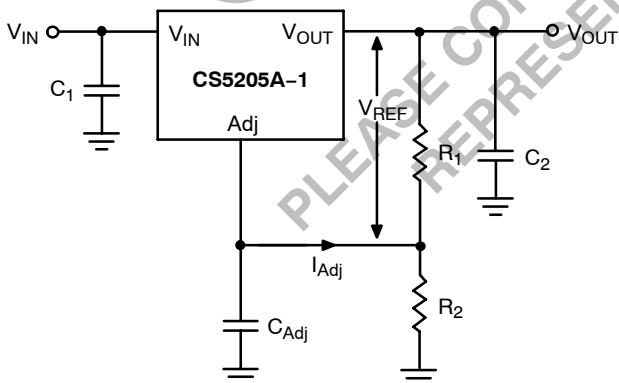

**Figure 7. Resistor Divider Scheme for the Adjustable Version**

**Stability Considerations**

The output or compensation capacitor helps determine three main characteristics of a linear regulator: start-up delay, load transient response and loop stability.

The capacitor value and type is based on cost, availability, size and temperature constraints. A tantalum or aluminum electrolytic capacitor is best, since a film or ceramic capacitor with almost zero ESR, can cause instability. The aluminum electrolytic capacitor is the least expensive solution. However, when the circuit operates at low temperatures, both the value and ESR of the capacitor will vary considerably. The capacitor manufacturers data sheet provides this information.

A 22  $\mu$ F tantalum capacitor will work for most applications, but with high current regulators such as the CS5205A-1 the transient response and stability improve with higher values of capacitor. The majority of applications for this regulator involve large changes in load current so the output capacitor must supply the instantaneous load current. The ESR of the output capacitor causes an immediate drop in output voltage given by:

$$\Delta V = \Delta I \times ESR$$

For microprocessor applications it is customary to use an output capacitor network consisting of several tantalum and ceramic capacitors in parallel. This reduces the overall ESR and reduces the instantaneous output voltage drop under load transient conditions. The output capacitor network should be as close as possible to the load for the best results.

**Protection Diodes**

When large external capacitors are used with a linear regulator it is sometimes necessary to add protection diodes. If the input voltage of the regulator gets shorted, the output capacitor will discharge into the output of the regulator. The discharge current depends on the value of the capacitor, the output voltage and the rate at which V<sub>IN</sub> drops. In the CS5205A-1 linear regulator, the discharge path is through a large junction and protection diodes are not usually needed. If the regulator is used with large values of output capacitance and the input voltage is instantaneously shorted to ground, damage can occur. In this case, a diode connected as shown in Figure 8 is recommended.

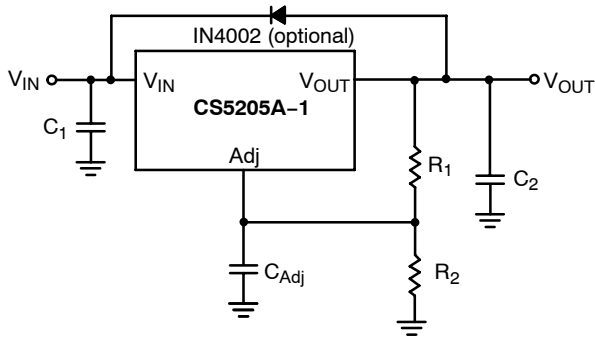

**Figure 8. Protection Diode Scheme for Adjustable Output Regulator**

**Output Voltage Sensing**

Since the CS5205A-1 is a three terminal regulator, it is not possible to provide true remote load sensing. Load regulation is limited by the resistance of the conductors connecting the regulator to the load.

Best load regulation occurs when R1 is connected directly to the output pin of the regulator as shown in Figure 9. If R1 is connected to the load, R\_C is multiplied by the divider ratio and the effective resistance between the regulator and the load becomes

$$R_C \times \left( \frac{R_1 + R_2}{R_1} \right)$$

where R\_C = conductor parasitic resistance.

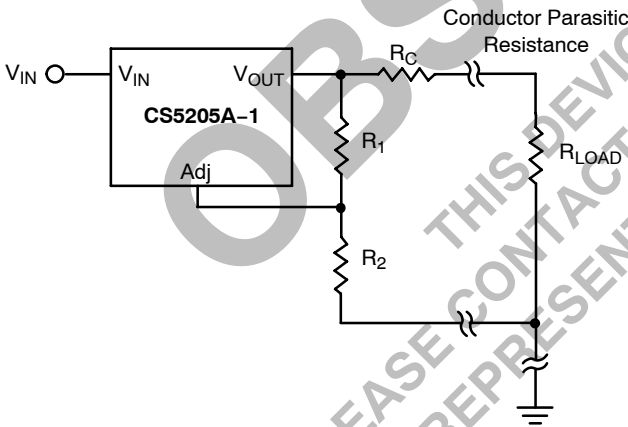

**Figure 9. Grounding Scheme for Adjustable Output Regulator to Minimize Parasitics**

**Calculating Power Dissipation and Heat Sink Requirements**

The CS5205A-1 linear regulator includes thermal shutdown and safe operating area circuitry to protect the device. High power regulators such as these usually operate at high junction temperatures so it is important to calculate the power dissipation and junction temperatures accurately to ensure that an adequate heat sink is used.

The case is connected to V\_OUT on the CS5205A-1, electrical isolation may be required for some applications. Thermal compound should always be used with high current regulators such as these.

The thermal characteristics of an IC depend on the following four factors:

1. Maximum Ambient Temperature T\_A (°C)
2. Power dissipation P\_D (Watts)
3. Maximum junction temperature T\_J (°C)
4. Thermal resistance junction to ambient R\_θJA (°C/W)

These four are related by the equation

$$T_J = T_A + P_D \times R_{\theta JA} \tag{1}$$

The maximum ambient temperature and the power dissipation are determined by the design while the maximum junction temperature and the thermal resistance depend on the manufacturer and the package type.

The maximum power dissipation for a regulator is:

$$P_{D(max)} = \{V_{IN(max)} - V_{OUT(min)}\}I_{OUT(max)} + V_{IN(max)}I_Q \tag{2}$$

where:

- V\_IN(max) is the maximum input voltage,
- V\_OUT(min) is the minimum output voltage,
- I\_OUT(max) is the maximum output current, for the application
- I\_Q is the maximum quiescent current at I\_OUT(max).

A heat sink effectively increases the surface area of the package to improve the flow of heat away from the IC and into the surrounding air.

Each material in the heat flow path between the IC and the outside environment has a thermal resistance. Like series electrical resistances, these resistances are summed to determine R\_θJA, the total thermal resistance between the junction and the surrounding air.

1. Thermal Resistance of the junction to case, R\_θJC (°C/W)
2. Thermal Resistance of the case to Heat Sink, R\_θCS (°C/W)
3. Thermal Resistance of the Heat Sink to the ambient air, R\_θSA (°C/W)

These are connected by the equation:

$$R_{\theta JA} = R_{\theta JC} + R_{\theta CS} + R_{\theta SA} \tag{3}$$

## CS5205A-1

The value for  $R_{\theta JA}$  is calculated using equation (3) and the result can be substituted in equation (1).

The value for  $R_{\theta JC}$  is normally quoted as a single figure for a given package type based on an average die size. For a high current regulator such as the CS5205A-1 the majority of the heat is generated in the power transistor section. The value for  $R_{\theta SA}$  depends on the heat sink type, while  $R_{\theta CS}$  depends on factors such as package type, heat sink interface

(is an insulator and thermal grease used?), and the contact area between the heat sink and the package. Once these calculations are complete, the maximum permissible value of  $R_{\theta JA}$  can be calculated and the proper heat sink selected. For further discussion on heat sink selection, see application note "Thermal Management," document number AND8036/D, available through the Literature Distribution Center or via our website at <http://onsemi.com>.

### ORDERING INFORMATION

Orderable Part Number	Type	Package	Shipping†
CS5205A-1GT3	5.0 A, Adj. Output	TO-220-3, Straight	50 Units/Rail
CS5205A-1GDP3	5.0 A, Adj. Output	D <sup>2</sup> PAK-3	50 Units/Rail
CS5205A-1GDPR3	5.0 A, Adj. Output	D <sup>2</sup> PAK-3	750 Tape & Reel

†For information on tape and reel specifications, including part orientation and tape sizes, please refer to our Tape and Reel Packaging Specifications Brochure, BRD8011/D.

**OBSOLETE**  
THIS DEVICE IS OBSOLETE  
PLEASE CONTACT YOUR ON SEMICONDUCTOR  
REPRESENTATIVE FOR INFORMATION

# CS5205A-1

## PACKAGE DIMENSIONS

TO-220-3  
T SUFFIX  
CASE 221A-08  
ISSUE AA

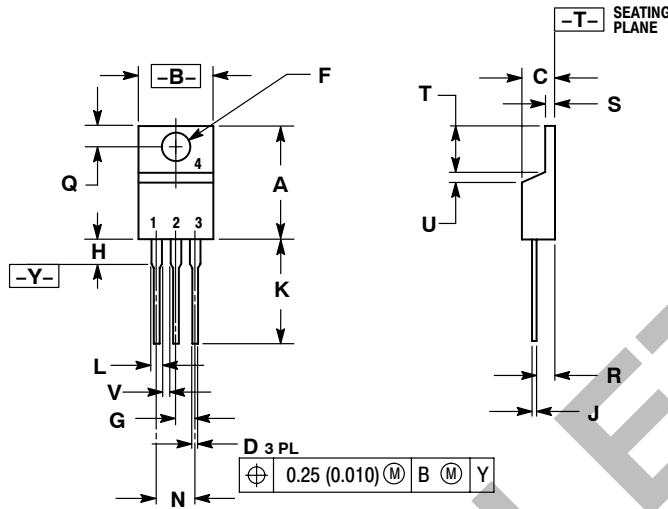

- NOTES:  
1. DIMENSIONING AND TOLERANCING PER ANSI Y14.5M, 1982.  
2. CONTROLLING DIMENSION: INCH.

DIM	INCHES		MILLIMETERS	
	MIN	MAX	MIN	MAX
A	0.560	0.625	14.23	15.87
B	0.380	0.420	9.66	10.66
C	0.140	0.190	3.56	4.82
D	0.025	0.035	0.64	0.89
F	0.139	0.155	3.53	3.93
G	0.100 BSC		2.54 BSC	
H	---	0.280	---	7.11
J	0.012	0.045	0.31	1.14
K	0.500	0.580	12.70	14.73
L	0.045	0.060	1.15	1.52
N	0.200 BSC		5.08 BSC	
Q	0.100	0.135	2.54	3.42
R	0.080	0.115	2.04	2.92
S	0.020	0.055	0.51	1.39
T	0.235	0.255	5.97	6.47
U	0.000	0.050	0.00	1.27
V	0.045	---	1.15	---

D<sup>2</sup>PAK-3  
DP SUFFIX  
CASE 418AB-01  
ISSUE O

**For D<sup>2</sup>PAK Outline and Dimensions – Contact Factory**

### PACKAGE THERMAL DATA

Parameter		TO-220-3	D <sup>2</sup> PAK-3	Unit
R <sub>θJC</sub>	Typical	1.6	1.6	°C/W
R <sub>θJA</sub>	Typical	50	10-50*	°C/W

\* Depending on thermal properties of substrate. R<sub>θJA</sub> = R<sub>θJC</sub> + R<sub>θCA</sub>

**OBSOLETE**  
 THIS DEVICE IS OBSOLETE  
 PLEASE CONTACT YOUR ON SEMICONDUCTOR  
 REPRESENTATIVE FOR INFORMATION

**ON Semiconductor** and  are registered trademarks of Semiconductor Components Industries, LLC (SCILLC). SCILLC reserves the right to make changes without further notice to any products herein. SCILLC makes no warranty, representation or guarantee regarding the suitability of its products for any particular purpose, nor does SCILLC assume any liability arising out of the application or use of any product or circuit, and specifically disclaims any and all liability, including without limitation special, consequential or incidental damages. "Typical" parameters which may be provided in SCILLC data sheets and/or specifications can and do vary in different applications and actual performance may vary over time. All operating parameters, including "Typicals" must be validated for each customer application by customer's technical experts. SCILLC does not convey any license under its patent rights nor the rights of others. SCILLC products are not designed, intended, or authorized for use as components in systems intended for surgical implant into the body, or other applications intended to support or sustain life, or for any other application in which the failure of the SCILLC product could create a situation where personal injury or death may occur. Should Buyer purchase or use SCILLC products for any such unintended or unauthorized application, Buyer shall indemnify and hold SCILLC and its officers, employees, subsidiaries, affiliates, and distributors harmless against all claims, costs, damages, and expenses, and reasonable attorney fees arising out of, directly or indirectly, any claim of personal injury or death associated with such unintended or unauthorized use, even if such claim alleges that SCILLC was negligent regarding the design or manufacture of the part. SCILLC is an Equal Opportunity/Affirmative Action Employer. This literature is subject to all applicable copyright laws and is not for resale in any manner.

#### PUBLICATION ORDERING INFORMATION

##### LITERATURE FULFILLMENT:

Literature Distribution Center for ON Semiconductor  
 P.O. Box 5163, Denver, Colorado 80217 USA  
**Phone:** 303-675-2175 or 800-344-3860 Toll Free USA/Canada  
**Fax:** 303-675-2176 or 800-344-3867 Toll Free USA/Canada  
**Email:** [orderlit@onsemi.com](mailto:orderlit@onsemi.com)

**N. American Technical Support:** 800-282-9855 Toll Free  
 USA/Canada  
**Europe, Middle East and Africa Technical Support:**  
 Phone: 421 33 790 2910  
**Japan Customer Focus Center**  
 Phone: 81-3-5773-3850

**ON Semiconductor Website:** [www.onsemi.com](http://www.onsemi.com)

**Order Literature:** <http://www.onsemi.com/orderlit>

For additional information, please contact your local  
 Sales Representative

## Looking for pricing, stock, or lifecycle information?

Click below to explore more details on WIN SOURCE:

-  [View CS5205A-1GDPR3 on WIN SOURCE](#)
-  [ON Semiconductor Information](#)

## Optimize Your Supply Chain with WIN SOURCE Solutions

-  Global Sourcing Solution
-  Obsolete Management
-  Cost Control Management
-  Shortage Management
-  Alternative Solution
-  Excess Inventory Management