



**THE DATASHEET OF  
LT8495HFE#PBF**





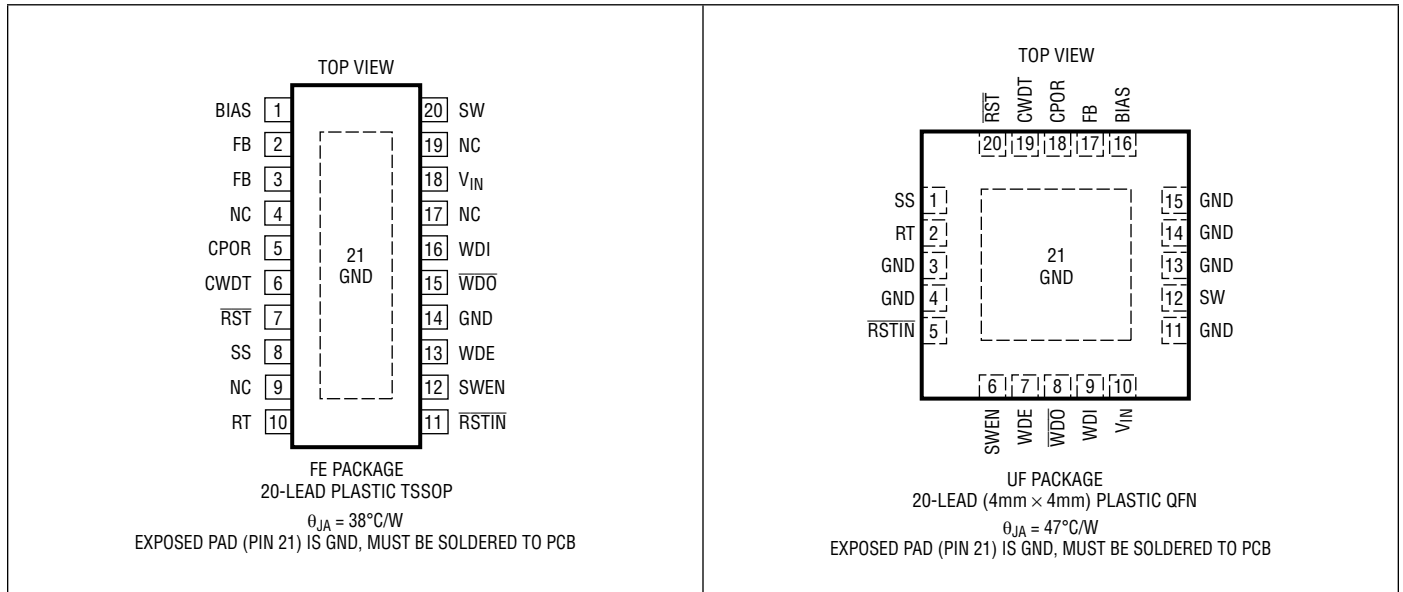
# LT8495

## ABSOLUTE MAXIMUM RATINGS

(Note 1)

$V_{IN}$ , BIAS Voltage .....	60V	CPOR, CWDT, SS Voltage .....	3V
SWEN, WDE, $\overline{RSTIN}$ Voltage .....	60V	Operating Junction Temperature Range	
FB Voltage .....	60V	LT8495E, LT8495I (Notes 2, 3) .....	-40°C to 125°C
SW Voltage .....	70V	LT8495H (Notes 2, 3) .....	-40°C to 150°C
WDI, $\overline{RST}$ , $\overline{WDO}$ Voltage .....	6V	Storage Temperature Range .....	-65°C to 150°C
RT Voltage .....	6V	Lead Temperature (Soldering, 10 sec)	
		FE Package .....	300°C

## PIN CONFIGURATION



## ORDER INFORMATION <http://www.linear.com/product/LT8495#orderinfo>

LEAD FREE FINISH	TAPE AND REEL	PART MARKING*	PACKAGE DESCRIPTION	TEMPERATURE RANGE
LT8495EUF#PBF	LT8495EUF#TRPBF	8495	20-Lead (4mm × 4mm) Plastic QFN	-40°C to 125°C
LT8495IUF#PBF	LT8495IUF#TRPBF	8495	20-Lead (4mm × 4mm) Plastic QFN	-40°C to 125°C
LT8495EFE#PBF	LT8495EFE#TRPBF	LT8495FE	20-Lead Plastic TSSOP	-40°C to 125°C
LT8495IFE#PBF	LT8495IFE#TRPBF	LT8495FE	20-Lead Plastic TSSOP	-40°C to 125°C
LT8495HFE#PBF	LT8495HFE#TRPBF	LT8495FE	20-Lead Plastic TSSOP	-40°C to 150°C

Consult LTC Marketing for parts specified with wider operating temperature ranges. \*The temperature grade is identified by a label on the shipping container.

For more information on lead free part marking, go to: <http://www.linear.com/leadfree/>

For more information on tape and reel specifications, go to: <http://www.linear.com/tapeandreeel/>. Some packages are available in 500 unit reels through designated sales channels with #TRMPBF suffix.

**ELECTRICAL CHARACTERISTICS** The ● denotes the specifications which apply over the full operating junction temperature range, otherwise specifications are at  $T_A = 25^\circ\text{C}$ .  $V_{IN} = V_{SWEN} = 12\text{V}$ ,  $V_{BIAS} = V_{WDE} = 5\text{V}$ , unless otherwise noted (Note 2).

PARAMETER	CONDITIONS		MIN	TYP	MAX	UNITS
Minimum $V_{IN}$ Operating Voltages	$V_{BIAS} < 2.5\text{V}$	●		2.4	2.5	V
	$V_{BIAS} \geq 2.5\text{V}$	●			0	V
Minimum BIAS Operating Voltages	$V_{IN} < 2.5\text{V}$	●		2.4	2.5	V
	$V_{IN} \geq 2.5\text{V}$	●			0	V
Power Switch Driver (PSD) Overvoltage Threshold (Note 4)	$V_{IN}$ or BIAS Rising	●	32.1	34	36.5	V
	$V_{IN}$ or BIAS Falling	●	32	33.9	36.4	V
Power Switch Driver (PSD) Overvoltage Threshold Hysteresis (Note 4)				100		mV
Quiescent Current from $V_{IN}$	$V_{SWEN} = 0\text{V}$ , $V_{WDE} = 0\text{V}$ , $V_{RSTIN} = 0\text{V}$			0.3	0.9	$\mu\text{A}$
	$V_{SWEN} = 5\text{V}$ , $V_{WDE} = 0\text{V}$ , $V_{FB} = V_{RSTIN} = 1.25\text{V}$			3.0	4.8	$\mu\text{A}$
	$V_{SWEN} = 5\text{V}$ , $V_{WDE} = 5\text{V}$ , $V_{FB} = V_{RSTIN} = 1.25\text{V}$			3.1	4.9	$\mu\text{A}$
	$V_{SWEN} = 5\text{V}$ , $V_{WDE} = 0\text{V}$ , $V_{FB} = V_{RSTIN} = 1.25\text{V}$ (LT8495E, LT8495I)	●		3.0	6.2	$\mu\text{A}$
	(LT8495H)	●		3.0	8.0	$\mu\text{A}$
	$V_{SWEN} = 5\text{V}$ , $V_{WDE} = 5\text{V}$ , $V_{FB} = V_{RSTIN} = 1.25\text{V}$ (LT8495E, LT8495I)	●		3.1	6.3	$\mu\text{A}$
(LT8495H)	●		3.1	8.0	$\mu\text{A}$	
Quiescent Current from BIAS	$V_{SWEN} = 0\text{V}$ , $V_{WDE} = 0\text{V}$ , $V_{RSTIN} = 0\text{V}$			0.07	0.5	$\mu\text{A}$
	$V_{SWEN} = 5\text{V}$ , $V_{WDE} = 0\text{V}$ , $V_{FB} = V_{RSTIN} = 1.25\text{V}$			1.7	2.8	$\mu\text{A}$
	$V_{SWEN} = 5\text{V}$ , $V_{WDE} = 5\text{V}$ , $V_{FB} = V_{RSTIN} = 1.25\text{V}$			6.0	8.5	$\mu\text{A}$
	$V_{SWEN} = 5\text{V}$ , $V_{WDE} = 0\text{V}$ , $V_{FB} = V_{RSTIN} = 1.25\text{V}$ (LT8495E, LT8495I)	●		1.7	4.0	$\mu\text{A}$
	(LT8495H)	●		1.7	11	$\mu\text{A}$
	$V_{SWEN} = 5\text{V}$ , $V_{WDE} = 5\text{V}$ , $V_{FB} = V_{RSTIN} = 1.25\text{V}$ (LT8495E, LT8495I)	●		6.0	10.0	$\mu\text{A}$
(LT8495H)	●		6.0	15.5	$\mu\text{A}$	
BIAS to $V_{IN}$ Comparator Threshold	$V_{BIAS} - V_{IN}$ , $V_{BIAS}$ Rising, $V_{IN} = 12\text{V}$	●	0.55	0.90	1.2	V
	$V_{BIAS} - V_{IN}$ , $V_{BIAS}$ Falling, $V_{IN} = 12\text{V}$	●	0.17	0.37	0.57	V
	Hysteresis (Rising-Falling Threshold)	●	0.20	0.53	0.80	V
Feedback Voltage		●	1.178	1.202	1.230	V
FB Pin Bias Current (Note 7)	$V_{FB} = 1.202\text{V}$			0.1	20	nA
FB Voltage Line Regulation	$5\text{V} \leq V_{IN} \leq 32\text{V}$ , $V_{BIAS} = 5\text{V}$			0.2	10	m%/V
	$5\text{V} \leq V_{IN} \leq 32\text{V}$ , $V_{BIAS} = 0\text{V}$			0.2	10	m%/V
Minimum Switch Off-Time				70		ns
Minimum Switch On-Time				95		ns
Switching Frequency	$R_T = 68.1\text{k}$	●	0.92	1.0	1.06	MHz
	$R_T = 324\text{k}$	●	219	250	280	kHz
Switch Current Limit at Min. Duty Cycle (Note 5)		●	2.1	2.55	2.95	A
Switch Current Limit at Max. Duty Cycle (Note 6)		●	1.3	1.85	2.4	A
Switch $V_{CESAT}$	$I_{SW} = 1.2\text{A}$			340		mV
Switch Leakage Current (Note 7)	$V_{SW} = 12\text{V}$ , $V_{SWEN} = 0\text{V}$			0.01	1	$\mu\text{A}$
Soft-Start Charging Current (Note 7)	$V_{SS} = 100\text{mV}$	●	5.2	8.2	12.2	$\mu\text{A}$
SWEN Pin Current (Note 7)	$V_{SWEN} = 1.2\text{V}$			0	25	nA
	$V_{SWEN} = 5\text{V}$			35	200	nA
	$V_{SWEN} = 12\text{V}$			240	550	nA
SWEN Rising Voltage Threshold		●	0.9	1	1.1	V
SWEN Voltage Hysteresis				30		mV

## ELECTRICAL CHARACTERISTICS

The ● denotes the specifications which apply over the full operating junction temperature range, otherwise specifications are at  $T_A = 25^\circ\text{C}$ .  $V_{IN} = V_{SWEN} = 12\text{V}$ ,  $V_{BIAS} = V_{WDE} = 5\text{V}$ , unless otherwise noted (Note 2).

PARAMETER	CONDITIONS		MIN	TYP	MAX	UNITS
RSTIN Pin Current (Note 7)	$V_{RSTIN} = 1.2\text{V}$ $V_{RSTIN} = 5\text{V}$ $V_{RSTIN} = 12\text{V}$			0 35 240	25 200 550	nA nA nA
RSTIN Threshold as % of $V_{FB}$ Regulation Voltage		●	86	92	97	%
RSTIN Low to RST Asserted ( $t_{UV}$ )	Step $V_{RSTIN}$ from 1.3V to 0.9V	●	8	23	60	$\mu\text{s}$
Watchdog Timeout and Reset Delay Period ( $t_{RST}$ ) (Note 8)	$C_{POR} = 4700\text{pF}$ , Watchdog Timeout Not Occurring at Same Time as the Reset Delay	●	8.5	9.5	11.85	ms
Watchdog Upper Boundary ( $t_{WDU}$ ) (Note 8)	$C_{WDT} = 1000\text{pF}$	●	14.9	16.7	20.9	ms
Watchdog Lower Boundary ( $t_{WDL}$ ) (Note 8)	$C_{WDT} = 1000\text{pF}$	●	580	650	812	$\mu\text{s}$
RST Output Voltage Low	$I_{SINK} = 1.25\text{mA}$ $I_{SINK} = 100\mu\text{A}$ , $V_{BIAS} = 1.3\text{V}$ , $V_{IN} = 0\text{V}$ $I_{SINK} = 100\mu\text{A}$ , $V_{IN} = 1.3\text{V}$ , $V_{BIAS} = 0\text{V}$	● ● ●		33 15 15	150 150 150	mV mV mV
RST Leakage Current	$V_{RSTIN} = 1.2\text{V}$ , $V_{RST} = 5\text{V}$ (LT8495E, LT8495I) $V_{RSTIN} = 1.2\text{V}$ , $V_{RST} = 5\text{V}$ (LT8495H)	● ●		0 0	0.3 1.0	$\mu\text{A}$ $\mu\text{A}$
WDO Output Voltage Low	$I_{SINK} = 1.25\text{mA}$	●		120	420	mV
WDO Leakage Current	$V_{WDO} = 5\text{V}$	●		0	0.25	$\mu\text{A}$
WDI Pin Current	$V_{WDI} = 5\text{V}$			0	0.1	$\mu\text{A}$
WDI Input Rising Threshold		●	0.4	0.8	1.25	V
WDI Voltage Hysteresis				58		mV
WDI Input Pulse Width		●	300			ns
WDE Pin Current (Note 7)	$V_{WDE} = 1.2\text{V}$ $V_{WDE} = 5\text{V}$ $V_{WDE} = 12\text{V}$			0 35 240	25 200 550	nA nA nA
WDE Rising Voltage Threshold		●	0.9	1	1.1	V
WDE Voltage Hysteresis				30		mV

**Note 1:** Stresses beyond those listed under Absolute Maximum Ratings may cause permanent damage to the device. Exposure to any Absolute Maximum Rating condition for extended periods may affect device reliability and lifetime. Voltages are with respect to GND pin unless otherwise noted.

**Note 2:** The LT8495E is guaranteed to meet performance specifications from  $0^\circ\text{C}$  to  $125^\circ\text{C}$  junction temperature. Specifications over the  $-40^\circ\text{C}$  to  $125^\circ\text{C}$  operating junction temperature range are assured by design, characterization and correlation with statistical process controls. The LT8495I is guaranteed to meet performance specifications from  $-40^\circ\text{C}$  to  $125^\circ\text{C}$  junction temperature. The LT8495H is guaranteed over the full  $-40^\circ\text{C}$  to  $150^\circ\text{C}$  operating junction temperature range. Operating lifetime is derated at junction temperatures greater than  $125^\circ\text{C}$ .

**Note 3:** This IC includes overtemperature protection that is intended to protect the device during momentary overload conditions. Junction temperature will exceed the maximum operating range when

overtemperature protection is active. Continuous operation above the specified maximum operating junction temperature may impair device reliability.

**Note 4:** See Power Supplies and Operating Limits in the Applications Information section for more details.

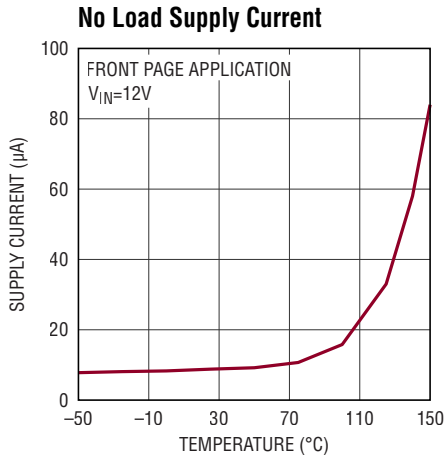
**Note 5:** Current limit guaranteed by design and/or correlation to static test. Slope Compensation reduces current limit at higher duty cycles.

**Note 6:** Max duty cycle current limit measured at 1MHz switching frequency.

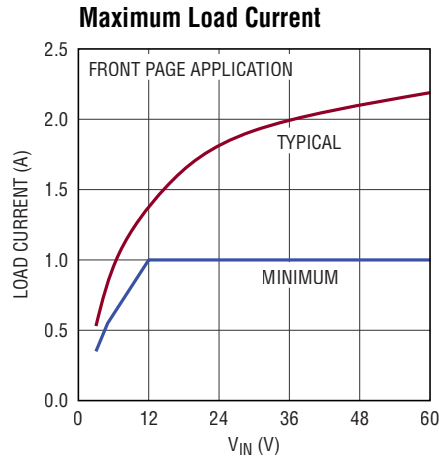
**Note 7:** Polarity specification for all currents into pins is positive. All voltages are referenced to GND unless otherwise specified.

**Note 8:** This specification is guaranteed for only the exact capacitance as listed in the conditions. Variation of the capacitance from the exact listed value will cause proportional variation to  $t_{RST}$ ,  $t_{WDU}$  and  $t_{WDL}$ .

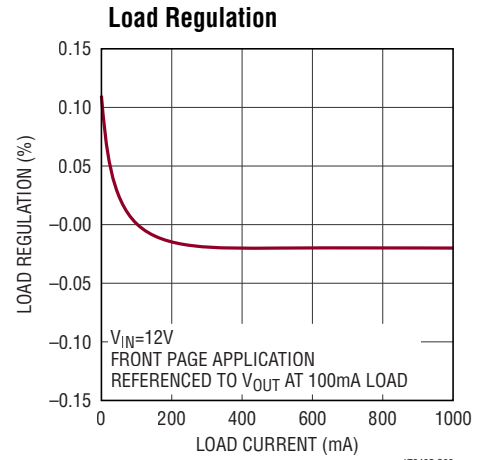
**TYPICAL PERFORMANCE CHARACTERISTICS**  $T_A = 25^\circ\text{C}$ , unless otherwise noted.



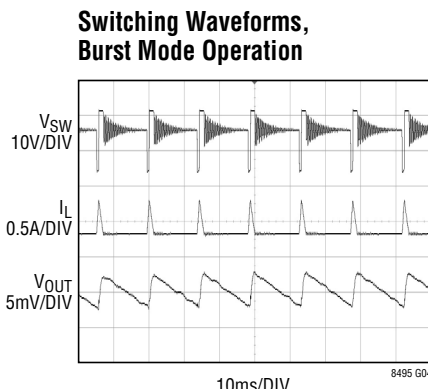
8495 G01



8495 G02

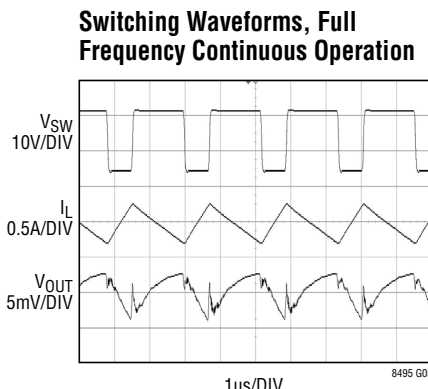


LT8495 G03



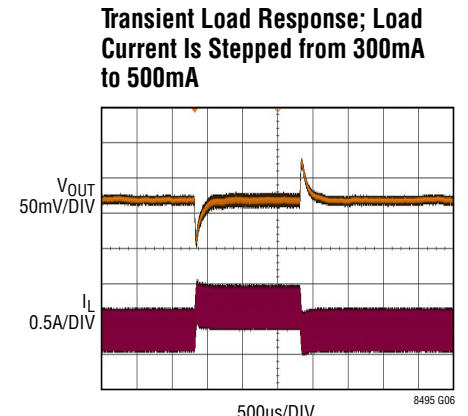
8495 G04

FRONT PAGE APPLICATION  
 $V_{IN} = 12\text{V}$   
 $V_{OUT} = 5\text{V}$   
 $I_{LOAD} = 20\text{mA}$



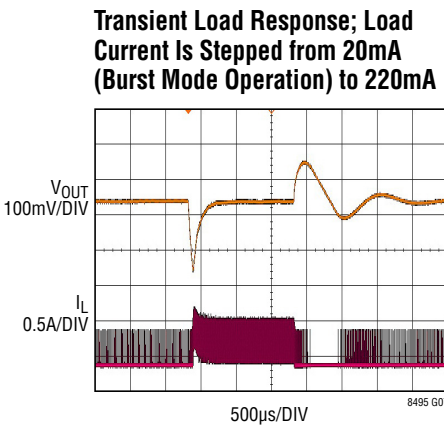
8495 G05

FRONT PAGE APPLICATION  
 $V_{IN} = 12\text{V}$   
 $V_{OUT} = 5\text{V}$   
 $I_{LOAD} = 0.5\text{A}$



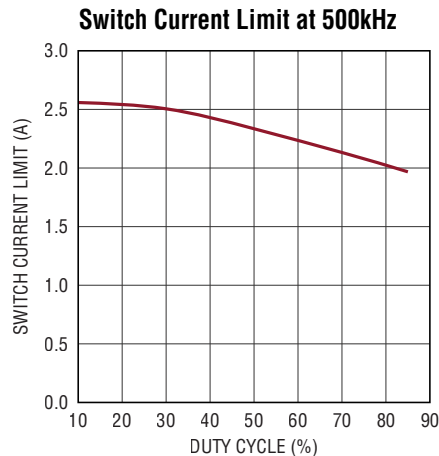
8495 G06

FRONT PAGE APPLICATION  
 $V_{IN} = 12\text{V}$   
 $V_{OUT} = 5\text{V}$

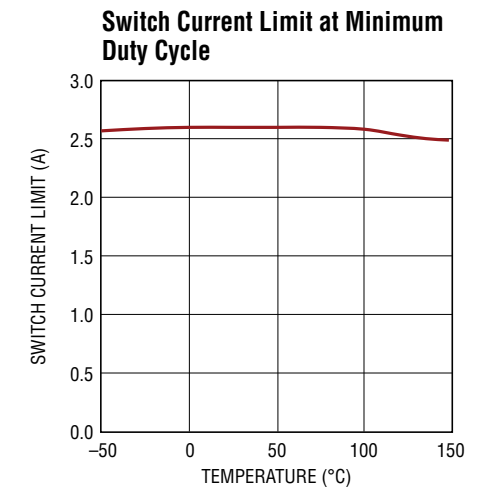


8495 G07

FRONT PAGE APPLICATION  
 $V_{IN} = 12\text{V}$   
 $V_{OUT} = 5\text{V}$

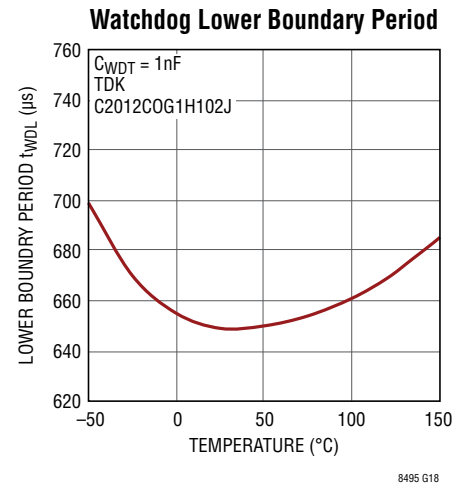
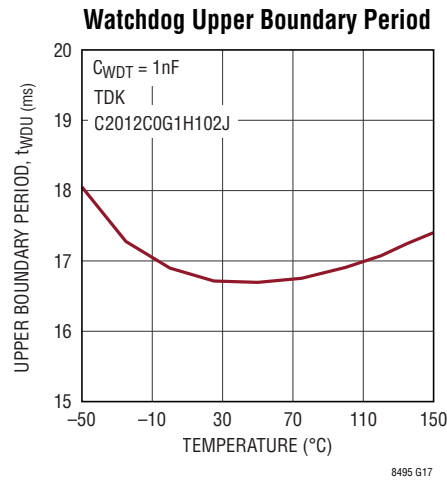
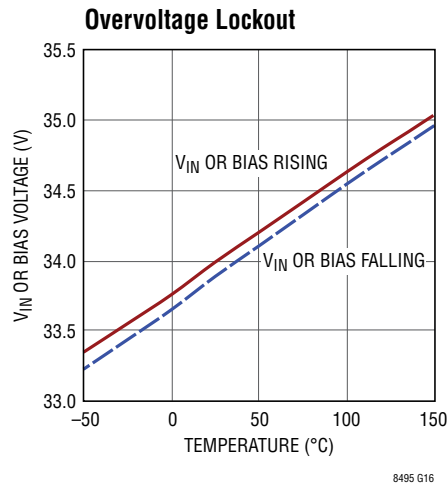
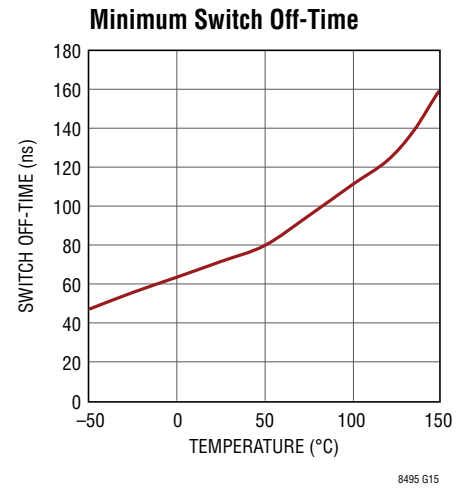
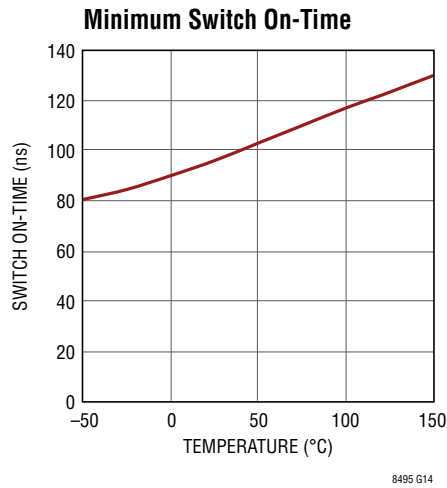
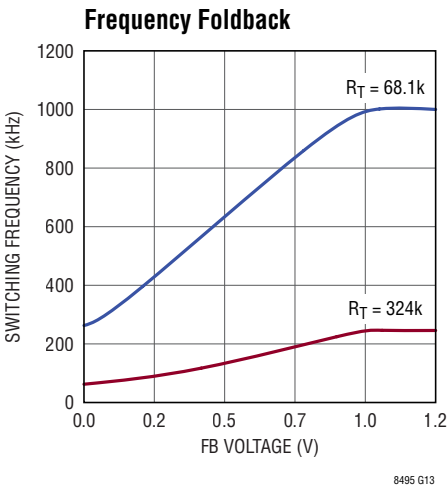
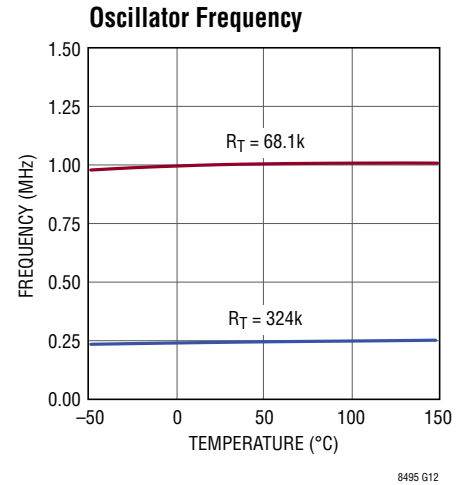
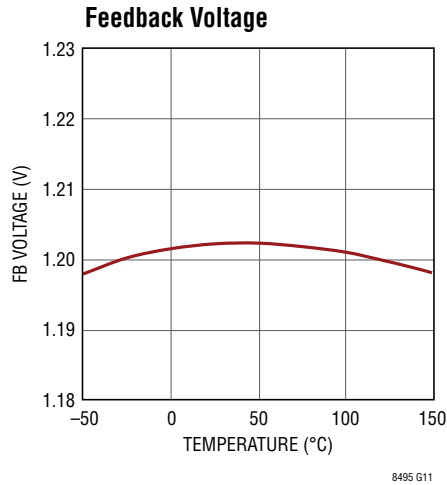
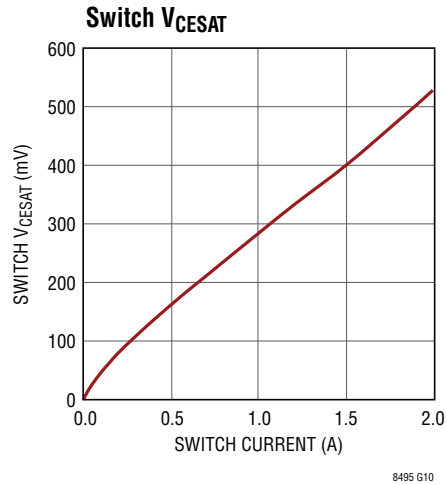


8495 G08



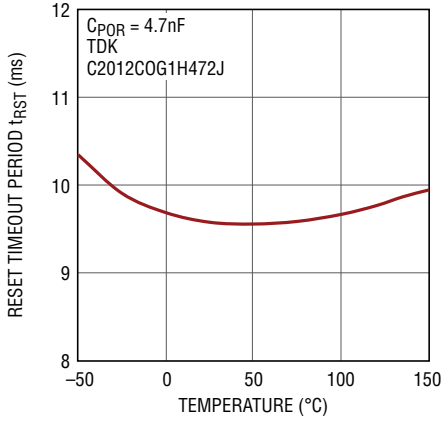
8495 G09

## TYPICAL PERFORMANCE CHARACTERISTICS $T_A = 25^\circ\text{C}$ , unless otherwise noted.



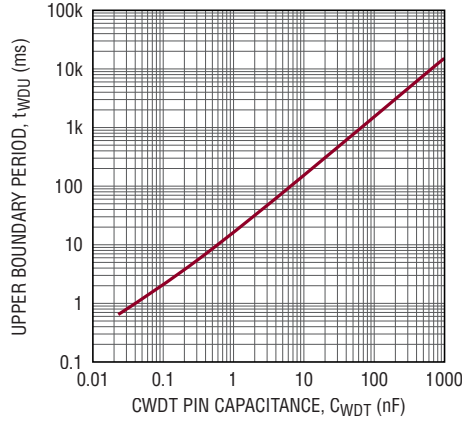
**TYPICAL PERFORMANCE CHARACTERISTICS**  $T_A = 25^\circ\text{C}$ , unless otherwise noted.

**Reset Timeout Period**



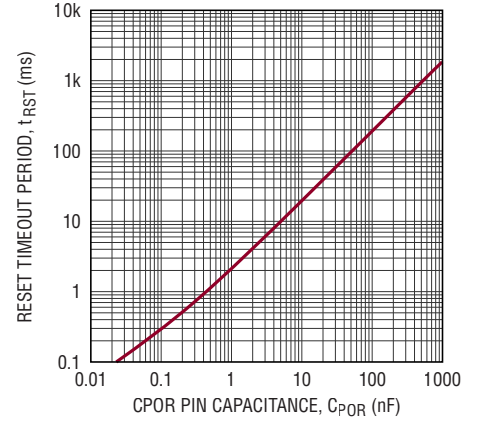
8495 G19

**Watchdog Upper Boundary Period vs Capacitance**



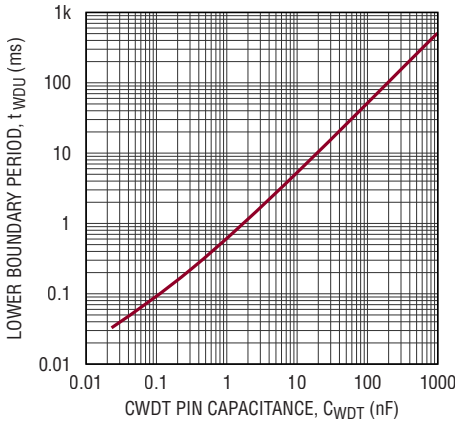
8495 G20

**Reset Timeout Period vs Capacitance**



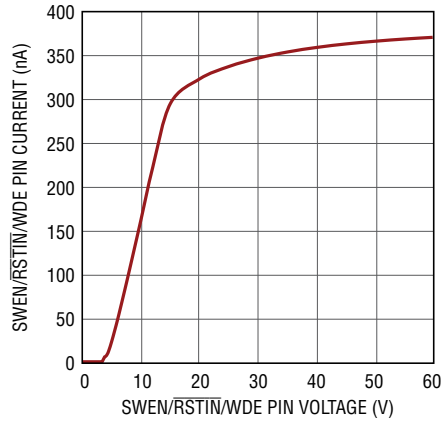
8495 G21

**Watchdog Lower Boundary Period vs Capacitance**



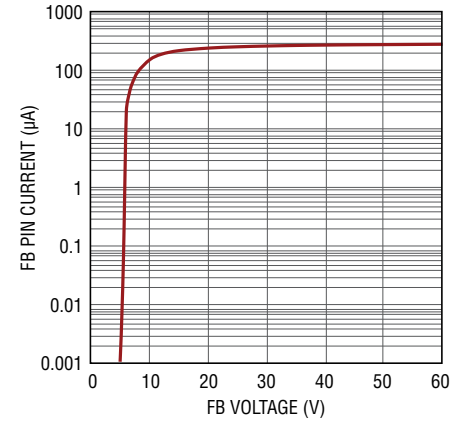
8495 G22

**SWEN/RSTIN/WDE Pin Current**



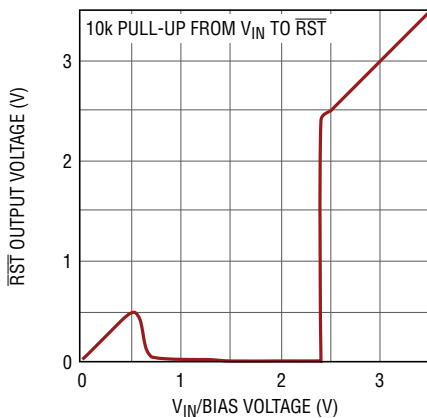
8495 G23

**FB Pin Current**



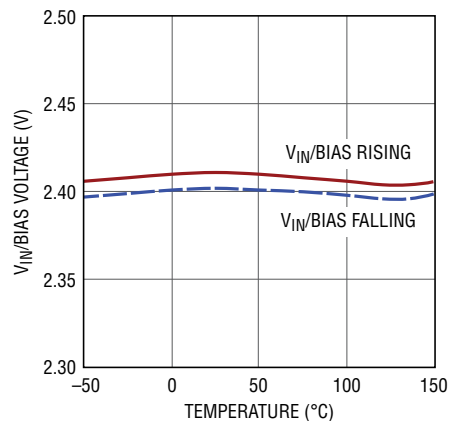
8495 G24

**RST Output Voltage vs Supply Voltage**



8495 G25

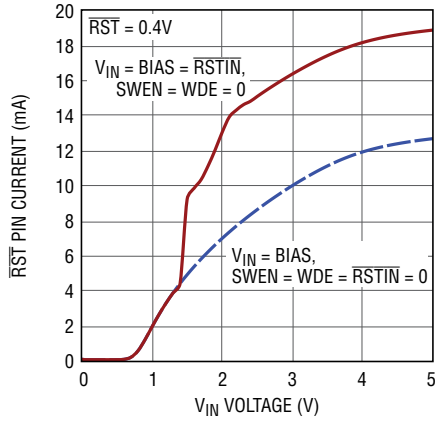
**Internal UVLO**



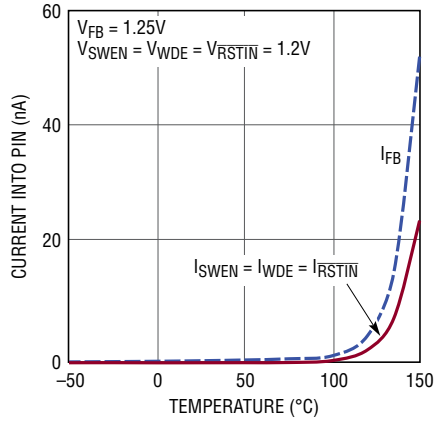
8495 G26

**TYPICAL PERFORMANCE CHARACTERISTICS**  $T_A = 25^\circ\text{C}$ , unless otherwise noted.

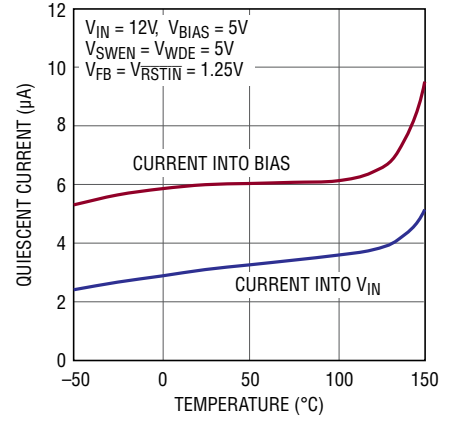
**RST Pin Current vs Supply Voltage**



**Pin Current**



**Quiescent Current**



## PIN FUNCTIONS (QFN/TSSOP)

**SS (Pin 1/Pin 8):** Soft-Start Pin. Place a soft-start capacitor on this pin. Upon start-up, the SS pin will be charged by a (nominally) 256k resistor to about 2.1V.

**RT (Pin 2/Pin 10):** Oscillator Frequency Set Pin. Place a resistor from this pin to ground to set the internal oscillator frequency. Minimize capacitance on this pin. See the Applications Information section for more details.

**GND (Pins 3, 4, 11, 13, 14, 15, Exposed Pad 21/Pin 14, Exposed Pad 21):** Ground. Solder all pins and the exposed pad directly to the local ground plane. The exposed pad metal of the package provides both electrical contact to ground and good thermal contact to the printed circuit board.

**NC (Pins 4, 9, 17, 19, TSSOP only):** No Connects: These pins are not connected to internal circuitry and must be left floating to ensure fault tolerance.

**$\overline{\text{RSTIN}}$  (Pin 5/Pin 11):** Reset Input Reference. Connect a resistor divider to  $\overline{\text{RSTIN}}$  to set the threshold voltage for asserting  $\overline{\text{RST}}$ . The  $\overline{\text{RSTIN}}$  voltage is compared to an internal 1.1V reference.  $\overline{\text{RSTIN}}$  voltages lower than the reference cause  $\overline{\text{RST}}$  to assert low.

**SWEN (Pin 6/Pin 12):** Switch Enable Detect Pin. This pin enables/disables the switching regulator and soft-start. A resistor divider can be connected to SWEN to perform an undervoltage lockout function.

**WDE (Pin 7/Pin 13):** Watchdog Timer Enable Pin. Drive above 1.1V to enable the watchdog timer function. When WDE is low, the  $\overline{\text{WDO}}$  output driver is disabled causing the pin to be high impedance.

**$\overline{\text{WDO}}$  (Pin 8/Pin 15):** Watchdog Out. Active low, open-drain output.  $\overline{\text{WDO}}$  asserts low if WDE is enabled and the microcontroller fails to drive the WDI pin of the LT8495 with the appropriate signal.

**WDI (Pin 9/Pin 16):** Watchdog Timer Input Pin. This pin receives the watchdog signal from a microcontroller. If the appropriate signal is not received,  $\overline{\text{WDO}}$  will pulse low for a period equal to the reset delay timer period ( $t_{\text{RST}}$ ).

**$V_{\text{IN}}$  (Pin 10/Pin 18):** Supply Input Pin. This pin is typically connected to the input of the DC/DC converter. Must be locally bypassed.

**SW (Pin 12/Pin 20):** Switch Pin. This is the collector of the internal NPN power switch. Minimize trace area connected to this pin to minimize EMI.

**BIAS (Pin 16/Pin 1):** Supply Input Pin. This pin is typically connected to the output of the DC/DC converter in cases where  $V_{\text{IN}}$  can be higher than  $V_{\text{OUT}}$ . Must be locally bypassed.

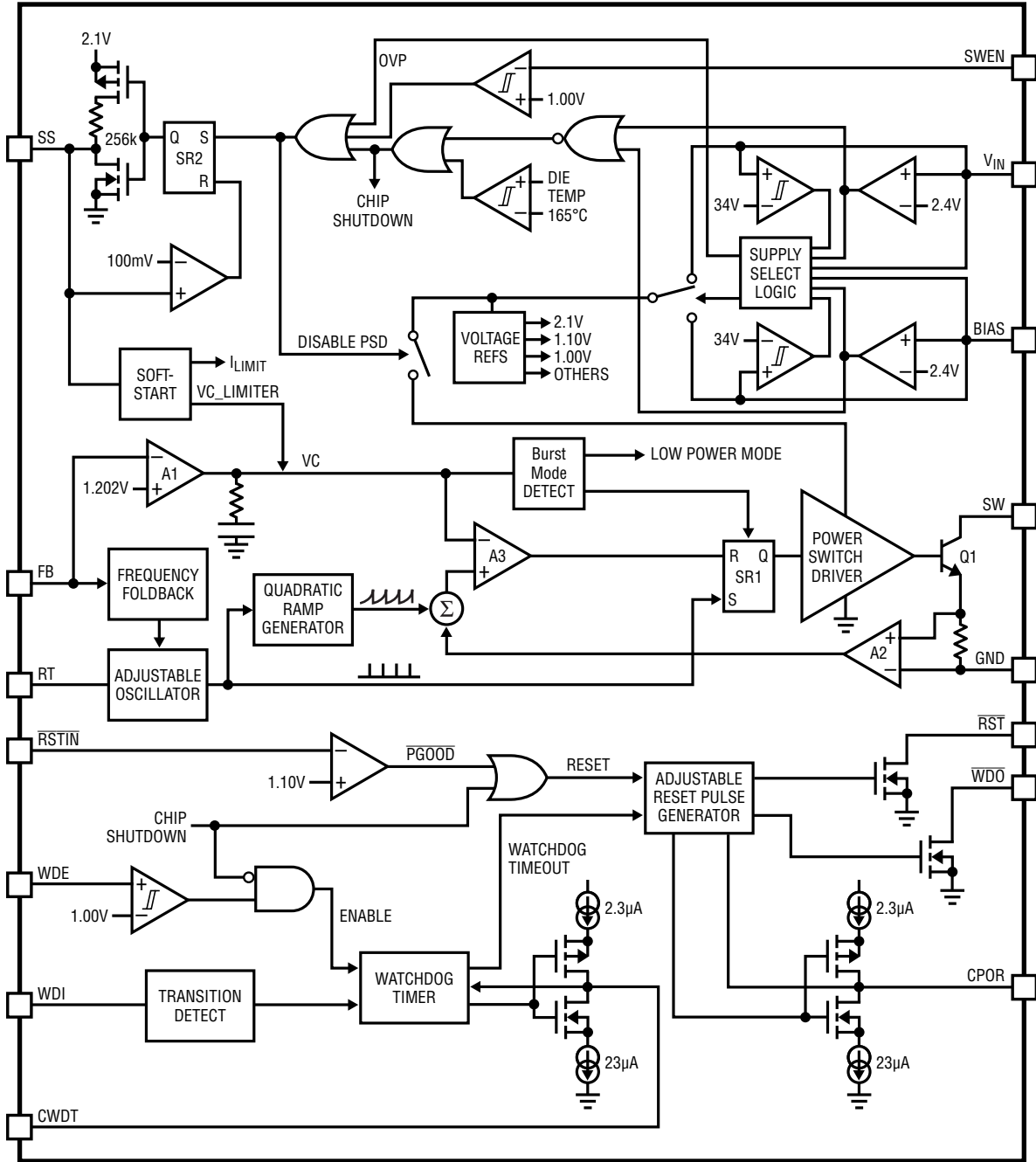
**FB (Pin 17/Pins 2, 3):** Output Voltage Feedback Pin. The LT8495 regulates the FB pin to 1.202V. Connect a resistor divider between the output, FB and GND to set the regulated output voltage.

**CPOR (Pin 18/Pin 5):**  $\overline{\text{WDO}}$  and  $\overline{\text{RST}}$  Active Delay Period Programming Pin. Attach an external capacitor ( $C_{\text{POR}}$ ) to GND to set the period ( $t_{\text{RST}}$ ). See the Applications Information section for more information.

**CWDT (Pin 19/Pin 6):** Watchdog Timer Programming Pin. Place a capacitor ( $C_{\text{WDT}}$ ) between this pin and ground to adjust the watchdog timer upper ( $t_{\text{WDU}}$ ) and lower ( $t_{\text{WDL}}$ ) boundary periods. See the Applications Information section for more information.

**$\overline{\text{RST}}$  (Pin 20/Pin 7):** Active Low, Open-Drain Reset. Asserts low when  $\overline{\text{RSTIN}}$  is less than  $\sim 1.1\text{V}$  (see Electrical Characteristics). After  $\overline{\text{RSTIN}}$  rises,  $\overline{\text{RST}}$  will remain asserted low for the period ( $t_{\text{RST}}$ ) set by the capacitor on the CPOR pin.

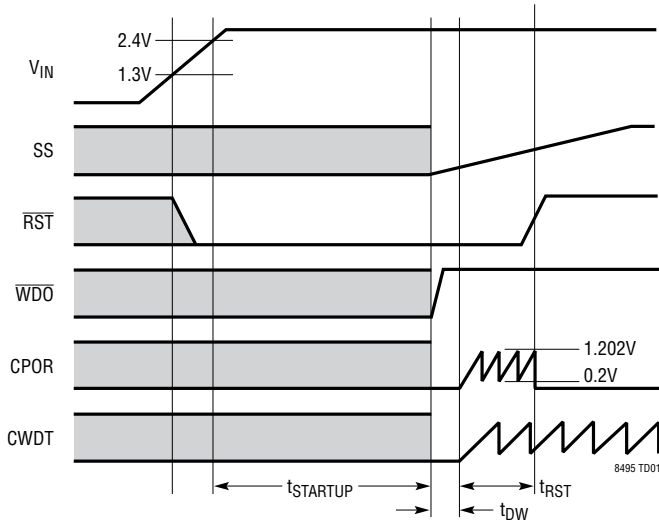
**BLOCK DIAGRAM**



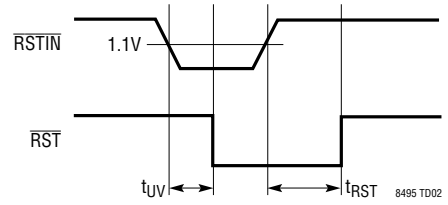
8495 BD

# TIMING DIAGRAMS

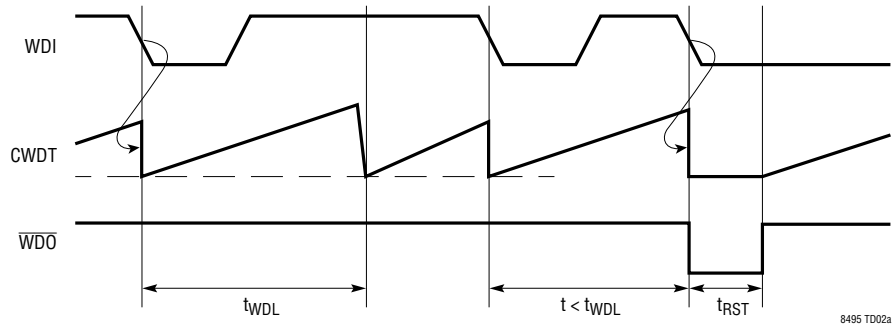
**Start-Up Timing**



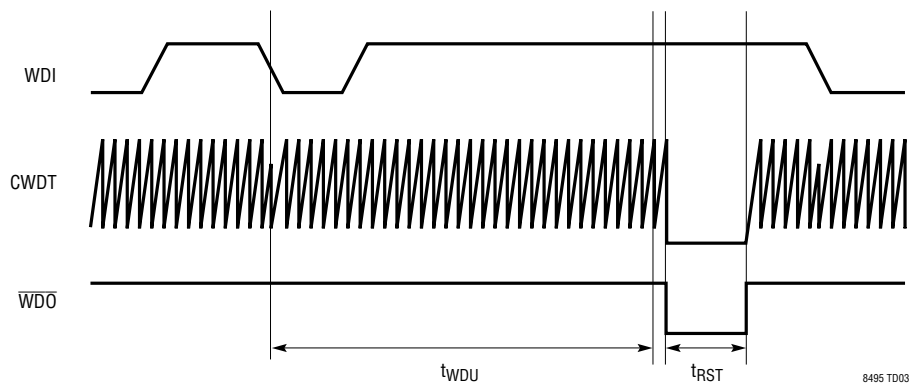
**RSTIN Timing**



**Watchdog Timing, Lower Boundary**



**Watchdog Timing, Upper Boundary**



$t_{STARTUP}$  = TIME REQUIRED TO START UP THE CHIP, APPROXIMATELY 1ms  
 $t_{DW}$  = TIME REQUIRED TO START UP THE WATCHDOG OR POR TIMER, APPROXIMATELY 200 $\mu$ s  
 $t_{UV}$  = TIME REQUIRED TO ASSERT  $\overline{RST}$  LOW AFTER  $\overline{RSTIN}$  GOES BELOW ITS THRESHOLD, APPROXIMATELY 23 $\mu$ s  
 $t_{RST}$  = PROGRAMMED RESET PERIOD  
 $t_{WDU}$  = WATCHDOG UPPER BOUNDARY PERIOD, APPROXIMATELY 31 RAMPING CYCLES ON  $\overline{CWDT}$  PIN  
 $t_{WDL}$  = WATCHDOG LOWER BOUNDARY PERIOD, APPROXIMATELY 1 RAMPING CYCLE ON  $\overline{CWDT}$  PIN

## OPERATION

The LT8495 is a constant-frequency, current mode SEPIC/boost/flyback regulator with power-on reset and a watchdog timer. Operation can be best understood by referring to the Block Diagram. The switching regulation, watchdog timer and reset detection functions are controlled by the SWEN, WDE and  $\overline{\text{RSTIN}}$  pins respectively. If all three pins are grounded, the part enters shutdown with minimal current drawn from the  $V_{\text{IN}}$  and BIAS sources. If any of these three pins are driven above their respective thresholds, this part is turned on.

### Switching Regulator Operation

In the Block Diagram, the adjustable oscillator, with frequency set by the external  $R_T$  resistor, enables an RS latch, turning on the internal power switch. An amplifier and comparator monitor the switch current flowing through an internal sense resistor, turning the switch off when this current reaches a level determined by the voltage at VC. An error amplifier adjusts the VC voltage by measuring the output voltage through an external resistor divider tied to the FB pin. If the error amplifier's output voltage (VC) increases, more current is delivered to the output; if the VC voltage decreases, less current is delivered. An active clamp on the VC voltage provides current limit. An internal regulator provides power to the control circuitry.

In order to improve efficiency, the NPN power switch driver (see Block Diagram) supplies NPN base current from whichever of  $V_{\text{IN}}$  and BIAS has the lower supply voltage. However, if either of them is below 2.4V or above 34V (typical values), the power switch draws current from the other pin. If both supply pins are below 2.4V or above 34V then switching activity is stopped.

To further optimize efficiency, the LT8495 automatically enters Burst Mode operation in light load situations. Between bursts, all circuitry associated with controlling the output switch is shut down, reducing the  $V_{\text{IN}}$ /BIAS pin supply currents to be less than 3 $\mu\text{A}$  to 6 $\mu\text{A}$  typically (see Electrical Characteristics table).

### Start-Up Operation

Several functions are provided to enable a very clean start-up for the LT8495.

- First, the SWEN pin voltage is monitored by an internal voltage reference to give a precise turn-on threshold. An external resistor divider can be connected from the input power supply to the SWEN pin to provide a user-programmable undervoltage lock-out function.
- Second, the soft-start circuitry provides for a gradual ramp-up of the switch current. When the part is brought out of shutdown, the external SS capacitor is first discharged, and then an integrated 256k resistor pulls the SS pin up to  $\sim 2.1\text{V}$ . By connecting an external capacitor to the SS pin, the voltage ramp rate on the pin can be set. Typical values for the soft-start capacitor range from 100nF to 1 $\mu\text{F}$ .
- Finally, the frequency foldback circuit reduces the maximum switching frequency when the FB pin is below 1V. This feature reduces the minimum duty cycle that the part can achieve thus allowing better control of the switch current during start-up.

### Power-On Reset and Watchdog Timer Operation

The LT8495 has a power-on reset (POR) circuit and a reset timer to assert the  $\overline{\text{RST}}$  pin for a minimum amount of time. After initial power up the open-drain  $\overline{\text{RST}}$  pin is asserted low for a programmable reset delay time (see the Timing Diagrams). During normal operation, the  $\overline{\text{RST}}$  pin can also be asserted when either the  $\overline{\text{RSTIN}}$  pin is below its threshold or the chip enters shutdown due to an abnormal condition. After the chip exits shutdown and the  $\overline{\text{RSTIN}}$  pin rises above its threshold, the  $\overline{\text{RST}}$  pin is released after the reset delay time which is programmable through the CPOR pin.

The watchdog timer typically monitors a microcontroller's activity. The watchdog timer can be enabled or disabled by applying a logic signal to the WDE pin. When enabled, the watchdog timer requires successive negative edges on the WDI pin to happen within a programmed time window to keep  $\overline{\text{WDO}}$  from pulsing low. Therefore, if the time between the two negative WDI edges is too short or too long, the  $\overline{\text{WDO}}$  pin will be pulsed low. When the  $\overline{\text{WDO}}$  pin pulls low, a reset timer keeps the  $\overline{\text{WDO}}$  pin low for a delay programmed by the CPOR pin. The  $\overline{\text{WDO}}$  pin will go high again after the reset timer expires or the chip shuts down (see the Timing Diagrams). The window periods can be set through the CWDT pin.

## APPLICATIONS INFORMATION

### Low Ripple Burst Mode Operation

To enhance efficiency at light loads, the LT8495 regulator enters low ripple Burst Mode operation keeping the output capacitor charged to the proper voltage while minimizing the input quiescent current. During Burst Mode operation, the LT8495 regulator delivers single-cycle bursts of current to the output capacitor with each followed by a sleep period where the output power is delivered to the load by the output capacitor. The quiescent currents of  $V_{IN}/BIAS$  are reduced to less than  $3\mu A$  to  $6\mu A$  typically during the sleep time (see Electrical Characteristics table).

As the load current decreases towards a no-load condition, the frequency of single current pulses decreases (see Figure 1), therefore the percentage of time that the LT8495 operates in sleep mode increases, resulting in reduced average input current and thus high efficiency even at very low loads.

By maximizing the time between pulses, the LT8495 quiescent current is minimized. Therefore, to optimize the quiescent current performance at light loads, the current in the feedback resistor divider and the reverse current in the external diode must be minimized, as these appear to the output as load currents. More specifically, during

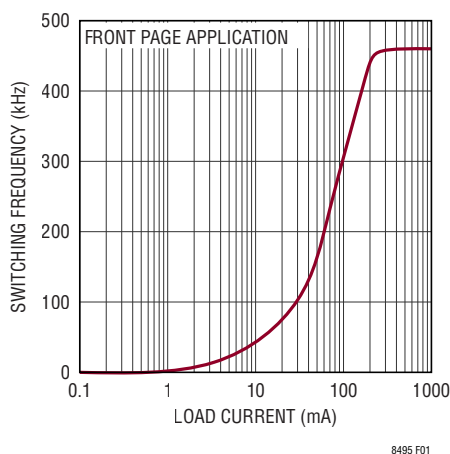


Figure 1. Switching Frequency in Burst Mode Operation

the sleep time, the boost converter has the reverse diode leakage current conducting from output to input, while the SEPIC converter has leakage current conducting from output to ground. Use the largest possible feedback resistors and a low leakage Schottky diode in applications with ultralow Q current.

In Burst Mode operation, the burst frequency and the charge delivered with each pulse will not change with output capacitance. Therefore, the output voltage ripple will be inversely proportional to the output capacitance. In a typical application with a  $47\mu F$  output capacitor, the output ripple is about 10mV and with two  $47\mu F$  output capacitors the output ripple is about 5mV (see Switching Waveforms, Burst Mode Operation in Typical Performance Characteristics section). The output voltage ripple can continue to be decreased by increasing the output capacitance.

At higher output loads the LT8495 regulator runs at the frequency programmed by the  $R_T$  resistor and operates as a standard current mode regulator. The transition between high current mode and low ripple Burst Mode operation is seamless, and will not disturb the output voltage.

### Chip Enable Pins

The SWEN, WDE and  $\overline{RSTIN}$  pins are used to enable various portions of the LT8495. The lowest current state is when all three pins are at 0V which disables all functions of the LT8495. Raising any of these pins above their respective input threshold voltages (see Electrical Characteristics section) activates the core circuits of the LT8495. Start-up of the LT8495 core circuits typically requires about 1ms (see the Timing Diagram). See the sections Enabling the Switching Regulator, Watchdog Timer, and Reset Conditions for further details about SWEN, WDE and  $\overline{RSTIN}$  respectively.

### Enabling the Switching Regulator

The SWEN pin is used to enable or disable the switching regulator. This pin operates independently of the watchdog enable (WDE) and the RST control input ( $\overline{RSTIN}$ ). The rising threshold of SWEN is typically 1V, with 30mV of hysteresis. The switching regulator is disabled by driving the SWEN pin below this threshold which deactivates the NPN power switch. The switching regulator is enabled by

## APPLICATIONS INFORMATION

driving SWEN above its threshold. Before active switching begins, the soft-start capacitor is quickly discharged then slowly charged causing a gradual start-up of the regulator. SWEN can be connected to  $V_{IN}$  if “always on” operation is desired, although some current will flow into the SWEN pin (see Typical Performance Characteristics) increasing overall bias current of the system. Also, a resistor divider can be connected to SWEN to create an undervoltage lockout function (see Undervoltage Lockouts) for more information.

### Setting the Output Voltage

The output voltage is programmed with a resistor divider from output to the FB pin (R2) and from the FB pin to ground (R1). Choose the 1% resistors according to:

$$R2 = R1 \left( \frac{V_{OUT}}{1.202} - 1 \right)$$

Note that choosing larger resistors decreases the quiescent current of the application circuits. In low load applications, choosing larger resistors is more critical since the part enters Burst Mode operation with lower quiescent current.

### Power Switch Duty Cycle

In order to maintain loop stability and deliver adequate current to the load, the power NPN (Q1 in the Block Diagram) cannot remain “on” for 100% of each clock cycle. The maximum allowable duty cycle is given by:

$$DC_{MAX} = \frac{T_P - \text{Minimum Switch Off-Time}}{T_P} \cdot 100\%$$

where  $T_P$  is the clock period and the Minimum Switch Off-Time (found in the Electrical Characteristics) is typically 70ns.

Conversely, the power NPNs (Q1 in the Block Diagram) cannot remain “off” for 100% of each clock cycle, and will turn on for a minimum time (Minimum Switch On-Time) when in regulation. This Minimum Switch On-Time governs the minimum allowable duty cycle given by:

$$DC_{MIN} = \frac{\text{Minimum Switch On-Time}}{T_P} \cdot 100\%$$

where  $T_P$  is the clock period and Minimum Switch On-Time (found in the Electrical Characteristics) is typically 95ns.

The application should be designed such that the operating duty cycle (DC) is between  $DC_{MIN}$  and  $DC_{MAX}$ . Normally, DC rises with higher  $V_{OUT}$  and lower  $V_{IN}$ .

Duty cycle equations for both boost and SEPIC topologies are given below, where  $V_D$  is the diode forward voltage drop and  $V_{CESAT}$  is typically 340mV at 1.2A.

For the boost topology:

$$DC \cong \frac{V_{OUT} - V_{IN} + V_D}{V_{OUT} + V_D - V_{CESAT}}$$

For the SEPIC topology:

$$DC \cong \frac{V_{OUT} + V_D}{V_{IN} + V_{OUT} + V_D - V_{CESAT}}$$

The LT8495 can be used in configurations where the duty cycle is higher than  $DC_{MAX}$ , but it must be operated in the discontinuous conduction mode or Burst Mode operation so that the effective duty cycle is reduced.

### Setting the Switching Frequency

The LT8495 uses a constant frequency PWM architecture that can be programmed to switch from 250kHz to 1.5MHz by using a resistor tied from the RT pin to ground. Table 1 shows the necessary  $R_T$  values for various switching frequencies.

**Table 1. Switching Frequency vs  $R_T$  Value**

SWITCHING FREQUENCY (MHz)	$R_T$ VALUE (k $\Omega$ )
0.25	324
0.4	196
0.6	124
0.8	88.7
1.0	68.1
1.2	54.9
1.4	45.3
1.5	41.2

## APPLICATIONS INFORMATION

### Inductor Selection

**General Guidelines:** The high frequency operation of the LT8495 allows for the use of small surface mount inductors. For high efficiency, choose inductors with high frequency core material, such as ferrite, to reduce core losses. To improve efficiency, choose inductors with more volume for a given inductance. The inductor should have low DCR (copper wire resistance) to reduce  $I^2R$  losses, and must be able to handle the peak inductor current without saturating. Note that in some applications, the current handling requirements of the inductor can be lower, such as in the SEPIC topology when using uncoupled inductors, where each inductor only carries a fraction of the total switch current. Molded chokes or chip inductors usually do not have enough core area to support peak inductor currents in the 2A to 3A range. To minimize radiated noise, use a toroidal or shielded inductor. Note that the inductance of shielded types will drop more as current increases, and will saturate more easily.

**Minimum Inductance:** Although there can be a trade-off with efficiency, it is often desirable to minimize board space by choosing smaller inductors. When choosing an inductor, there are two conditions that limit the minimum inductance; (1) providing adequate load current, and (2) avoidance of subharmonic oscillation. Choose an inductance that is high enough to meet both of these requirements.

**Adequate Load Current:** Small value inductors result in increased ripple currents and thus, due to the limited peak switch current, decrease the average current that can be provided to a load ( $I_{OUT}$ ). In order to provide adequate load current, L should be at least:

$$L > \frac{DC \cdot V_{IN}}{2(f) \left( I_{LIM} - \frac{V_{OUT} \cdot I_{OUT}}{V_{IN} \cdot \eta} \right)}$$

For boost topologies, or:

$$L > \frac{DC \cdot V_{IN}}{2(f) \left( I_{LIM} - \frac{V_{OUT} \cdot I_{OUT}}{V_{IN} \cdot \eta} - I_{OUT} \right)}$$

for the SEPIC topologies.

where:

$L = L1 || L2$  for uncoupled SEPIC topology

DC = switch duty cycle (see previous section)

$I_{LIM}$  = switch current limit, typically about 2.35A at 50% duty cycle (see the Typical Performance Characteristics section)

$\eta$  = power conversion efficiency (typically 85% to 90% for boost and 80% to 85% for SEPIC at high currents)

f = switching frequency

Negative values of L indicate that the output load current  $I_{OUT}$  exceeds the switch current limit capability of the LT8495.

**Avoiding Subharmonic Oscillations:** The internal slope compensation circuit of LT8495 helps prevent the subharmonic oscillations that can occur when the duty cycle is greater than 50%, provided that the inductance exceeds a minimum value. In applications that operate with duty cycles greater than 50%, the inductance must be at least:

$$L > \frac{(V_{IN} - V_{CESAT}) \cdot (2DC - 1)}{0.76 \cdot (1.5 \cdot DC + 1) \cdot f \cdot (1 - DC)}$$

for boost and coupled inductor SEPIC, or:

$$L1 || L2 > \frac{(V_{IN} - V_{CESAT}) \cdot (2DC - 1)}{0.76 \cdot (1.5 \cdot DC + 1) \cdot f \cdot (1 - DC)}$$

for the uncoupled inductor SEPIC topologies.

**Maximum Inductance:** Excessive inductance can reduce current ripple to levels that are difficult for the current comparator (A2 in the Block Diagram) to cleanly discriminate, thus causing duty cycle jitter and/or poor regulation. The maximum inductance can be calculated by:

$$L_{MAX} = \frac{V_{IN} - V_{CESAT}}{I_{MIN(RIPPLE)}} \cdot \frac{DC}{f}$$

where  $L_{MAX}$  is  $L1 || L2$  for uncoupled SEPIC topologies and  $I_{MIN(RIPPLE)}$  is typically 150mA.

## APPLICATIONS INFORMATION

**Current Rating:** Finally, the inductor(s) must have a rating greater than its peak operating current to prevent inductor saturation resulting in efficiency loss.

In steady state, the peak and average input inductor currents (continuous conduction mode only) is given by:

$$I_{L1(\text{PEAK})} = \frac{V_{\text{OUT}} \cdot I_{\text{OUT}}}{V_{\text{IN}} \cdot \eta} + \frac{V_{\text{IN}} \cdot \text{DC}}{2 \cdot L1 \cdot f}$$

$$I_{L1(\text{AVG})} = \frac{V_{\text{OUT}} \cdot I_{\text{OUT}}}{V_{\text{IN}} \cdot \eta}$$

for the boost and uncoupled inductor SEPIC topology.

For uncoupled SEPIC topologies, the peak and average currents of the output inductor L2 is given by:

$$I_{L2(\text{PEAK})} = I_{\text{OUT}} + \frac{V_{\text{OUT}} \cdot (1 - \text{DC})}{2 \cdot L2 \cdot f}$$

$$I_{L2(\text{AVG})} = I_{\text{OUT}}$$

For the coupled inductor SEPIC:

$$I_{L(\text{PEAK})} = I_{\text{OUT}} \cdot \left[ 1 + \frac{V_{\text{OUT}}}{V_{\text{IN}} \cdot \eta} \right] + \frac{V_{\text{IN}} \cdot \text{DC}}{2 \cdot L \cdot f}$$

$$I_{L(\text{AVG})} = I_{\text{OUT}} \cdot \left[ 1 + \frac{V_{\text{OUT}}}{V_{\text{IN}} \cdot \eta} \right]$$

Note: Inductor current can be higher during load transients. It can also be higher during short circuit and start-up if inadequate soft-start capacitance is used. Thus,  $I_{L(\text{PEAK})}$  may be higher than the switch current limit of 2.95A, and the RMS inductor current is approximately equal to  $I_{L(\text{AVG})}$ . Choose an inductor having sufficient saturation current and RMS current ratings.

### Capacitor Selection

Low ESR (equivalent series resistance) capacitors should be used at the output to minimize the output ripple voltage. Multilayer ceramic capacitors are an excellent choice, as they have an extremely low ESR and are available in very small packages. X5R or X7R dielectrics are preferred, as these materials retain their capacitance over wider voltage and temperature ranges. Always use a capacitor with a sufficient voltage rating. Many capacitors rated at 2.2μF

to 20μF, particularly 0805 or 0603 case sizes, have greatly reduced capacitance at the desired output voltage. Solid tantalum or OS-CON capacitors can be used, but they will occupy more board area than a ceramic and will have a higher ESR with greater output ripple.

Ceramic capacitors also make a good choice for the input decoupling capacitor, which should be placed as closely as possible to the  $V_{\text{IN}}$  and BIAS pins of the LT8495. A 2.2μF to 4.7μF input capacitor is sufficient for most applications.

### Audible Noise

Ceramic capacitors are small, robust and have very low ESR. However, due to their piezoelectric nature, ceramic capacitors can sometimes create audible noise when used with the LT8495. During Burst Mode operation, the LT8495 regulator's switching frequency depends on the load current, and at very light loads the regulator can excite the ceramic capacitor at audio frequencies, generating audible noise. Since LT8495 operates at a lower current limit during Burst Mode operation, the noise is typically very quiet. If this is unacceptable, use a high performance tantalum or electrolytic capacitor at the output.

### Diode Selection

The diode used in boost or SEPIC topologies conducts current only during switch off-time. During switch on-time, the diode has reverse voltage across it. The peak reverse voltage is equal to  $V_{\text{OUT}}$  in the boost topology and equal to  $(V_{\text{OUT}} + V_{\text{IN}})$  in the SEPIC topology. Use a diode with a reverse voltage rating greater than the peak reverse voltage.

An additional consideration is the reverse leakage current. The leakage current appears to the output as load current and affects the efficiency, most noticeably, under light load conditions. In Burst Mode operation, after the inductor current vanishes, the reverse voltage across the boost diode is approximately equal to  $V_{\text{OUT}} - V_{\text{IN}}$  in the boost topology and  $V_{\text{OUT}}$  in the SEPIC topology. The percentage of time that the diode is reverse biased increases as load current decreases.

Schottky diodes that have larger forward voltages often have less leakage, so a trade-off exists between light load and high load efficiency. Also the Schottky diodes with larger reverse bias ratings may have less leakage at a given output voltage, therefore, superior leakage performance can be

## APPLICATIONS INFORMATION

achieved at the expense of diode size. Finally, keep in mind that the leakage current of a power Schottky diode goes up exponentially with junction temperature. Therefore, the Schottky diode must be selected with care to avoid excessive increase in light load supply current at high temperatures.

### Soft-Start

The LT8495 contains a soft-start circuit to limit peak switch currents during start-up. High start-up current is inherent in switching regulators since the feedback loop is saturated due to  $V_{OUT}$  being far from its final value. The regulator tries to charge the output capacitor as quickly as possible, which results in large peak currents. The start-up current can be limited by connecting an external capacitor (typically 100nF to 1 $\mu$ F) to the SS pin. This capacitor is slowly charged to  $\sim 2.1V$  by an internal 256k resistor once the part is activated. SS pin voltages below  $\sim 0.8V$  reduce the internal current limit. Thus, the gradual ramping of the SS voltage also gradually increases the current limit as the capacitor charges. This, in turn, allows the output capacitor to charge gradually toward its final value while limiting the start-up current. When the switching regulator shuts down the soft-start capacitor is automatically discharged to  $\sim 100mV$  or less before charging resumes, thus assuring that the soft-start occurs after every reactivation of the switching regulation.

### Power Supplies and Operating Limits

The LT8495 draws supply current from the  $V_{IN}$  and BIAS pins. The largest supply current draw occurs when the switching regulator is enabled (SWEN is high) and the power switch is toggling on and off. Under light load conditions the switching regulator enters Burst Mode operation where the power switch toggles infrequently and the input current is significantly reduced (see the Low Ripple Burst Mode Operation section).

**Power Switch Driver (PSD) Operating Range:** The NPN power switch is driven by a power switch driver (PSD) as shown in the Block Diagram. The driver must be powered by a supply ( $V_{IN}$  or BIAS) that is above the minimum operating voltage and below the PSD overvoltage threshold. These voltages are typically 2.4V and 34V respectively (see Electrical Characteristics).

If neither  $V_{IN}$  nor BIAS is within this operating range, the PSD and the switching regulator are automatically disabled. Voltages up to 60V are not harmful to the PSD, however, as discussed, switching regulation is automatically disabled when neither  $V_{IN}$  nor BIAS is in the valid operating range. See Table 2 for some example operating conditions.

**Reset and Watchdog Operating Voltage Limits:** The reset circuits operate properly as long as either  $V_{IN}$  or BIAS is above 1.3V (see Reset Conditions section). The watchdog timer operates properly when either  $V_{IN}$  or BIAS is between 2.5V and 60V. The table below gives some example operating conditions.

**Table 2: Operating Condition Examples**

$V_{IN}$ (V)	BIAS (V)	RESET CIRCUITS	WATCHDOG	SWITCHING REGULATOR
0	1.3	X		
1.3	0	X		
1	40	X	X	
40	40	X	X	
1	30	X	X	X
12	40	X	X	X

**Automatic Power Supply Selection:** In order to minimize power loss, the LT8495 draws as much of its required current as possible from the lowest suitable voltage supply ( $V_{IN}$  or BIAS) in accordance with the requirements described in the previous two sections. This selection is automatic and can change as  $V_{IN}$  and/or BIAS voltages change.

The LT8495 compares the  $V_{IN}$  and BIAS voltages to determine which is lower. The comparator has an offset and hysteresis as shown in the Electrical Characteristics section. The voltage comparison happens continuously when the power switch is toggling. The result of the latest comparison is latched inside the LT8495 when switching stops. If the power switch is not toggling, the LT8495 uses the last  $V_{IN}$  vs BIAS comparison to determine which supply is lower. After initial power up or any thermal lockout the LT8495 always concludes that  $V_{IN}$  is the lower supply voltage until subsequent voltage comparisons can be made while the power switch is toggling.

**BIAS Connection for SEPIC Converters:** For SEPIC converters, where  $V_{IN}$  can be above or below  $V_{OUT}$ , BIAS is typically connected to  $V_{OUT}$  which improves efficiency when

## APPLICATIONS INFORMATION

$V_{IN}$  voltage is higher than  $V_{OUT}$ . Connecting BIAS to  $V_{OUT}$  in a SEPIC topology also allows the switching regulator to operate with  $V_{IN}$  above 34V (typical switch driver overvoltage threshold) in cases where  $V_{OUT}$  is regulated below the PSD overvoltage threshold. Finally, connecting BIAS to  $V_{OUT}$  also allows the converter to operate from  $V_{IN}$  voltages less than 2.5V after  $V_{OUT}$  rises within the PSD operating range. This can be very useful in battery powered applications since the battery voltage drops as it discharges.

**BIAS Connection for Boost Converters:** For boost converters, BIAS is typically connected to  $V_{OUT}$  or to ground. Connecting BIAS to  $V_{OUT}$  allows the converter to operate with  $V_{IN} < 2.5V$  after  $V_{OUT}$  has risen within the PSD operating range. However, during no load conditions on  $V_{OUT}$ , despite  $V_{IN}$  being selected as the primary input supply, the overall power loss will be slightly elevated due to the small amount of current still being drawn from the higher voltage BIAS pin. To minimize boost converter power loss during no load conditions, connect BIAS instead to ground.

For boost applications with  $V_{OUT}$  higher than the PSD operating range, the BIAS pin should not typically be connected to  $V_{OUT}$ . The LT8495 will never draw the majority of its current from BIAS due to the excessive voltage, therefore this connection does not help to improve efficiency. Alternative choices for the BIAS pin connection are ground or another supply that is within the PSD operating range.

**Maximum  $V_{IN}$  for Boost Converters:**  $V_{IN}$  cannot generally be higher than  $V_{OUT}$  in boost topologies because of the DC path from  $V_{IN}$  to  $V_{OUT}$  through the inductor and the output diode. If  $V_{IN}$  must be higher than  $V_{OUT}$ , then the inductor must be powered by a separate supply that is always below  $V_{OUT}$ . Otherwise a SEPIC topology can be used.

Also, the LT8495 will not operate in a boost topology with  $V_{IN}$  voltages above the PSD operating range unless BIAS is connected to an alternative supply within the valid operating range.

**$V_{IN}$ /BIAS Ramp Rate:** While initially powering a switching converter application, the  $V_{IN}$ /BIAS ramp rate should be limited. High  $V_{IN}$ /BIAS ramp rates can cause excessive inrush currents in the passive components of the converter. This can lead to current and/or voltage overstress and may damage the passive components or the chip. Ramping rates

less than 500mV/ $\mu$ s, depending on component parameters, will generally prevent these issues. Also, be careful to avoid hot plugging. Hot plugging occurs when an active voltage supply is “instantly” connected or switched to the input of the converter. Hot plugging results in very fast input ramp rates and is not recommended. Finally, for more information, refer to Linear Application Note 88, which discusses voltage overstress that can occur when inductive source impedance is hot plugged to an input pin bypassed by ceramic capacitors.

### Watchdog Timer

The LT8495 includes an adjustable watchdog timer that can monitor a microcontroller activity. If a code execution error occurs, the watchdog timer can detect this and pull the open drain  $\overline{WDO}$  pin low.  $\overline{WDO}$  can be connected to  $\overline{RST}$  or to another input of the microcontroller to reset or interrupt the microcontroller. Note that the pull-up resistor must be connected to  $\overline{WDO}$  for proper operation. This resistor is often already integrated in the microcontroller.

The watchdog circuitry monitors negative edges on the WDI pin. The WDI pin’s negative going pulses are restricted to appear inside a programmed time window to prevent  $\overline{WDO}$  from going low. During a code execution error, the microcontroller will generate WDI pulses that are either too fast or too slow which will cause  $\overline{WDO}$  to assert low and force the microcontroller to reset the program (see the Timing Diagram section).

While monitoring WDI, if the time between any two falling edges is shorter than the watchdog lower boundary,  $t_{WDL}$  (see Figure 2), or longer than the watchdog upper boundary,  $t_{WDU}$  (see Figure 3),  $\overline{WDO}$  is pulled down for a programmable period of  $t_{RST}$  (see Reset Conditions section).

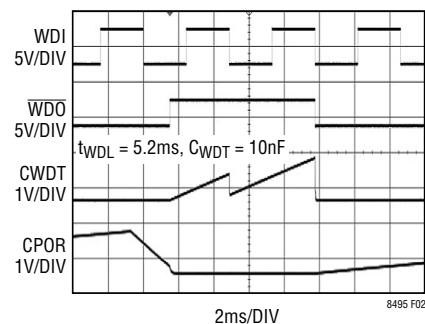


Figure 2. Window Watchdog Waveforms

## APPLICATIONS INFORMATION

Thus, the WDI period should be higher than  $t_{WDL}$ , and lower than  $t_{WDU}$  to keep  $\overline{WDO}$  high under normal conditions.  $\overline{WDO}$  also pulls low if no negative WDI edge occurs during the watchdog upper boundary period.

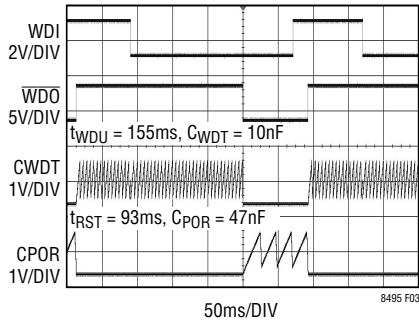


Figure 3. Timeout Watchdog Waveforms

**Selecting the Watchdog Timing Capacitor:** The watchdog timeout period is adjustable and can be optimized for software execution. The watchdog upper and lower boundary timeout periods ( $t_{WDU}$  and  $t_{WDL}$ ) are adjusted by connecting a capacitor,  $C_{WDT}$ , between the CWDT pin and ground.  $t_{WDU}$  is typically  $30 \cdot t_{WDL}$  for large  $C_{WDT}$  values (greater than about 50nF). For lower values this ratio reduces as shown in Figure 6.

To program the  $t_{WDU}$  and  $t_{WDL}$  periods, see the Watchdog Upper and Lower Boundary Periods vs Capacitance graphs in the Typical Characteristics section to select  $C_{WDT}$ . The required capacitor value can also be calculated from a given watchdog timeout period by using the following equation:

$$C_{WDT} = K_1 \cdot t_{WDU}$$

Where  $C_{WDT}$  is the external capacitor value in nF,  $t_{WDU}$  is the upper boundary period in ms, and  $K_1$  is their ratio with typical values shown in Figure 4.  $K_1$  can be approximated as 0.065nF/ms for upper boundaries greater than 50ms.

In addition, the following equation can be used to calculate the watchdog lower boundary period for a given  $C_{WDT}$  capacitor value.

$$t_{WDL} = K_2 \cdot C_{WDT}$$

Where  $t_{WDL}$  is the lower boundary in ms,  $C_{WDT}$  is the external capacitance in nF, and  $K_2$  is their ratio with typical values shown in Figure 5.  $K_2$  can be approximated as 0.52ms/nF for  $C_{WDT}$  values greater than 10nF.

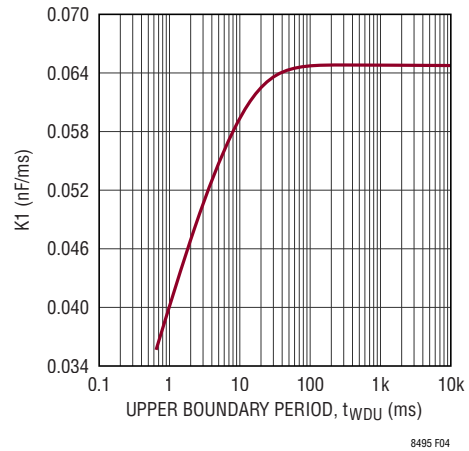


Figure 4. Watchdog Upper Boundary Parameter

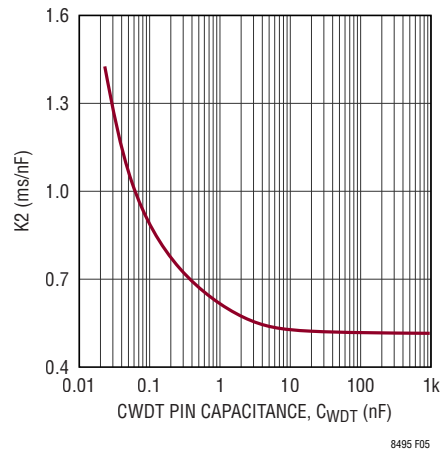


Figure 5. Watchdog Lower Boundary Parameter

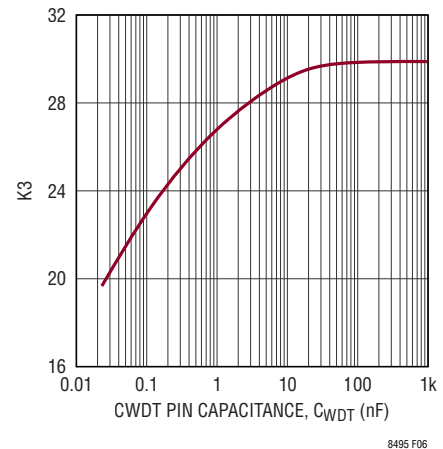


Figure 6. Upper and Lower Boundary Ratio



## APPLICATIONS INFORMATION

- RSTIN Undervoltage Lockout:** The open-drain  $\overline{\text{RST}}$  pin is asserted low if the  $\overline{\text{RSTIN}}$  input is below the 1.1V typical threshold (see Electrical Characteristics). This function enables the use of an external resistor divider to configure an under voltage detection circuit. This reset condition has no effect on the switching regulator or the watchdog timer. See the Undervoltage Lockouts section for more information.

A programmable timer delays the release of  $\overline{\text{RST}}$  by  $t_{\text{RST}}$  after all of the above reset conditions are no longer met. Before releasing  $\overline{\text{RST}}$ , the external  $C_{\text{POR}}$  capacitor ramps up and down for four cycles creating the  $t_{\text{RST}}$  delay (see Figure 8). To program the  $t_{\text{RST}}$  period, see the Reset Timeout Period vs Capacitance graphs in the Typical Characteristics section to select  $C_{\text{POR}}$ . The required capacitor value can also be calculated from a given reset timeout period by using the following equation:

$$C_{\text{POR}} = K4 \cdot t_{\text{RST}}$$

where  $C_{\text{POR}}$  is the external capacitor value in nF.  $t_{\text{RST}}$  is the reset timeout period in ms, and K4 is their ratio with typical values shown in Figure 9, K4 can be approximated as 0.51 nF/ms for reset timeout periods greater than 15ms. As described previously, this same timer is used to determine how long  $\overline{\text{WDO}}$  is asserted low during a watchdog timeout.

As an example, to create a 9.5ms  $t_{\text{RST}}$  timeout period, choose a  $C_{\text{POR}}$  capacitor value of 4.7nF. Leaving the  $C_{\text{POR}}$  pin unconnected will generate a  $t_{\text{RST}}$  period of approximately 40 $\mu$ s. The maximum period is limited by the largest available low leakage capacitor. The Electrical Characteristics section indicates the guaranteed tolerance of the timeout period for a given capacitance. The accuracy of the timeout period will also be affected by capacitor leakage (the nominal charging current is 2.3 $\mu$ A) and capacitor tolerance. A low leakage ceramic capacitor is recommended.

As discussed previously,  $\overline{\text{WDO}}$  is asserted low for a period of  $t_{\text{RST}}$  after a watchdog error occurs. This period is measured by counting four cycles on the CPOR pin in the same way that the reset delay is measured. If a watchdog timeout occurs at the same time as the reset delay period,

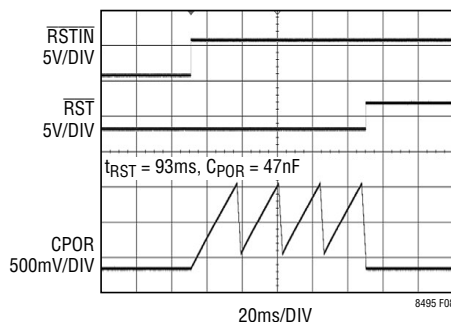


Figure 8. Reset Timer Waveforms

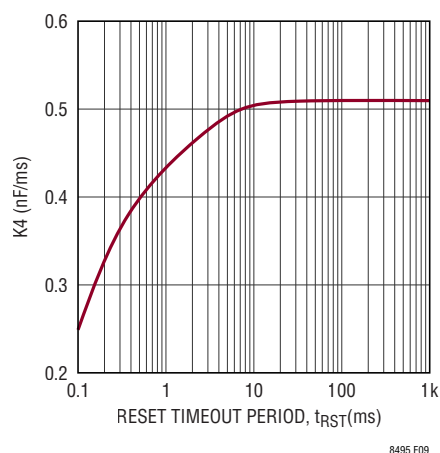


Figure 9. Reset Timer Parameter

the watchdog takes priority in the counter. Therefore,  $\overline{\text{WDO}}$  is always asserted low for four cycles of the CPOR pin, while the  $\overline{\text{RST}}$  delay may be extended beyond four cycles to a maximum of six cycles, thus increasing  $t_{\text{RST}}$  by up to 50%.

Finally note that the  $t_{\text{RST}}$  delay on the  $\overline{\text{RST}}$  pin does not affect the switching regulator or watchdog timer. The switching regulator and/or watchdog timer will start right after the part is no longer in the POR or thermal lockout condition.

### Undervoltage Lockouts

Undervoltage lockout (UVLO) functions can be implemented using the SWEN and/or  $\overline{\text{RSTIN}}$  pins. An undervoltage lockout can shut down appropriate circuitry to prevent undesired operation when input and/or output voltages are too low.

APPLICATIONS INFORMATION

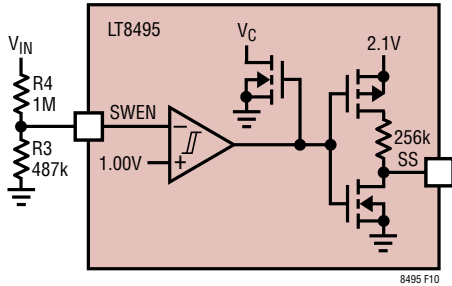


Figure 10. V<sub>IN</sub> Undervoltage Lockout

**Input UVLO:** Connecting a resistor divider from V<sub>IN</sub> to SWEN (see Figure 10) implements an input undervoltage lockout circuit. SWEN has an accurate rising threshold of 1.0V with 30mV of hysteresis (typical—see Electrical Specifications). By connecting a resistor divider from V<sub>IN</sub> to SWEN, the LT8495 will be programmed to disable the switching regulator when V<sub>IN</sub> drops below a desired threshold. Typically, this threshold is used in situations where the input supply is current limited, or has a relatively high source resistance. A switching regulator draws constant power from the source, so source current increases as source voltage drops. This looks like a negative resistance load to the source and can cause the source to current limit or latch low under low source voltage conditions. The input UVLO prevents the regulator from operating at source voltages where the problems might occur.

As shown in Figure 10, by connecting a resistor divider from V<sub>IN</sub> to SWEN, the falling undervoltage lockout threshold is set to:

$$V_{IN(UVLO)} = \frac{R3 + R4}{R3} \cdot 0.97V$$

From the previous equation, the resistor divider shown in Figure 10 gives the V<sub>IN</sub> pin a falling undervoltage lockout threshold of 2.96V. When V<sub>IN</sub> is below this threshold, the switching regulation is disabled and the SS pin starts to discharge. After choosing the value of R3, for example, R4 can be calculated using:

$$R4 = R3 \cdot \left( \frac{V_{IN(UVLO)}}{0.97} - 1 \right) \Omega$$

**Output UVLO:** Connecting the  $\overline{RST}$  and  $\overline{RSTIN}$  pins as shown in Figures 11 and 12 implements an output undervoltage lock out (UVLO) circuit. This circuit resets V<sub>OUT</sub> powered devices when V<sub>OUT</sub> is below a desired voltage by asserting the open drain  $\overline{RST}$  pin low. Note that a pull-up resistor is required on the  $\overline{RST}$  pin, but might already be integrated in the  $\mu C$ . There is typically a 23 $\mu s$  delay from the  $\overline{RSTIN}$  pin falling edge until  $\overline{RST}$  is asserted low (see Electrical Characteristics section) for glitch immunity of the  $\overline{RSTIN}$  pin. After  $\overline{RSTIN}$  rises above its threshold,  $\overline{RST}$  continues to be asserted low for a delayed time programmable by the CPOR pin capacitor.

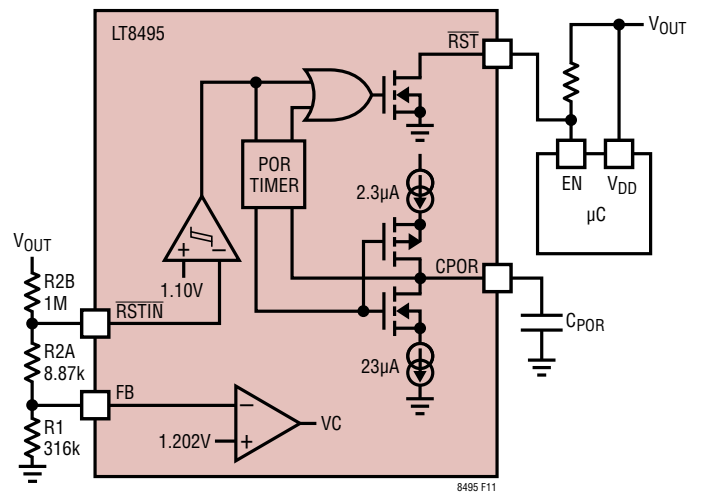


Figure 11.  $\overline{RSTIN}$  Reset Lockout

As shown in Figure 12, the R2 resistor (calculated in the Setting the Output Voltage section) is divided into two resistors, R2A & R2B to implement the UVLO function. Next, the following equations are used to calculate their values.

$$R2A = R1 \cdot \left( \frac{92\%}{UVLO\%_{NOM}} - 1 \right)$$

$$R2B = R2 - R2A$$

where UVLO%<sub>NOM</sub> is the desired nominal UVLO threshold voltage as a percentage of the nominal V<sub>OUT</sub>. UVLO%<sub>NOM</sub> is recommended to be 89.5% or less for most applications. Continue reading for more information about selecting UVLO%<sub>NOM</sub>.

## APPLICATIONS INFORMATION

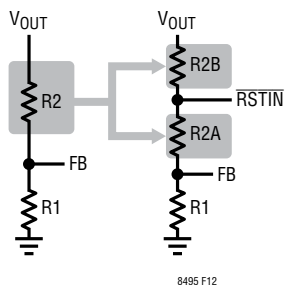


Figure 12.  $\overline{RSTIN}$  Pin Connection Options

When choosing  $UVLO\%_{NOM}$ , consider that the transient response to  $V_{OUT}$  load current steps may cause undershoot of  $V_{OUT}$ . Excessive  $V_{OUT}$  undershoot can cause  $\overline{RSTIN}$  to drop below the comparator threshold and activate  $\overline{RST}$ . The following equation includes the maximum  $\overline{RSTIN}$  comparator threshold (97% of the FB reference - see Electrical Characteristics) to show what the maximum UVLO threshold can be.

$$UVLO\%_{MAX} = UVLO\%_{NOM} \cdot \frac{97}{92}$$

For example, when choosing  $UVLO\%_{NOM} = 89.5\%$ ,  $UVLO\%_{MAX} = 94.36\%$  of  $V_{OUT}$ . Therefore the  $\overline{RST}$  pin may assert if  $V_{OUT}$  undershoots more than 5.64% below its steady-state regulated voltage. Choose a lower  $UVLO\%_{NOM}$  if more margin is required.

In addition, the choice of  $UVLO\%_{NOM}$  affects the minimum possible  $V_{OUT}$  voltage before  $\overline{RST}$  is asserted.

$$UVLO\%_{MIN} = UVLO\%_{NOM} \cdot \frac{86}{92}$$

For example, when using  $UVLO\%_{NOM} = 89.5\%$ ,  $UVLO\%_{MIN} = 83.66\%$  of  $V_{OUT}$ . Therefore the  $\overline{RST}$  pin may not assert unless  $V_{OUT}$  is 16.34% below its nominal value. Note that in terms of absolute  $V_{OUT}$  UVLO voltage one must also consider the tolerance of the FB regulation voltage and the R1, R2A and R2B resistor tolerances.

In the example shown in Figure 11,  $V_{OUT}$  is regulated to 5V. For a desired UVLO% of 89.5%, the calculated R1, R2A, and R2B values are 316k, 8.87k, and 1M respectively.

**POR UVLO:** When both  $V_{IN}$  and BIAS are too low for proper LT8495 operation (typically  $<2.4V$ ), the switching regulator and watchdog timers are disabled. For more information see the Reset Conditions section.

### High Temperature Considerations

For higher ambient temperatures, care should be taken in the layout of the PCB to ensure good heat sinking of the LT8495. The exposed pad on the bottom of the package must be soldered to a ground plane. This ground should be tied to large copper layers below with thermal vias; these layers will spread heat dissipated by the LT8495. Placing additional vias can reduce thermal resistance further. The maximum load current should be derated as the ambient temperature approaches the maximum junction rating. Power dissipation within the LT8495 is estimated by calculating the total power loss from an efficiency measurement and subtracting the diode loss, FB resistor loss and inductor loss. The die temperature is calculated by multiplying the LT8495 power dissipation by the thermal resistance from junction to ambient.

The power switch and its driver dissipate the most power in the LT8495 (see Block Diagram). Higher switch current, duty cycle and output voltage result in higher die temperature. Power loss in the Power Switch Driver also increases with higher input supply voltage. The PSD is supplied by the lowest suitable voltage on  $V_{IN}$  and BIAS. Connecting BIAS to a low voltage supply, often  $V_{OUT}$ , can reduce the maximum die temperature of the LT8495 (see Automatic Power Supply Selection section).

Also note that leakage current into the SWEN,  $\overline{RSTIN}$ , WDE, and FB pins increases at high junction temperatures (see Typical Performance Characteristics). The potential leakage current should be considered when choosing high value resistors connected to those pins.

**Thermal Lockout:** If the die temperature reaches approximately  $165^{\circ}C$ , the part will go into thermal lockout and the chip will be reset. The part will be enabled again when the die temperature has dropped by  $\sim 5^{\circ}C$  (nominal). See the Reset Conditions section for more details about the chip's state during thermal lockout

### Fault Tolerance

The LT8495 is designed to tolerate single fault condition in the TSSOP package. Shorting two adjacent pins together or leaving one single pin floating does not raise  $V_{OUT}$  or cause damage to the LT8495 regulator.

## APPLICATIONS INFORMATION

Table 3 and Table 4 show the effects that result from shorting adjacent pins and from a floating pin, respectively. The NC pins must be left floating to ensure fault tolerance. For the best fault tolerance to inadvertent adjacent pin shorts, the BIAS pin must be tied to something higher than 1.230V or to the output to avoid overvoltage during a short from FB to BIAS.

**Table 3. Effects of Pin Shorts (TSSOP)**

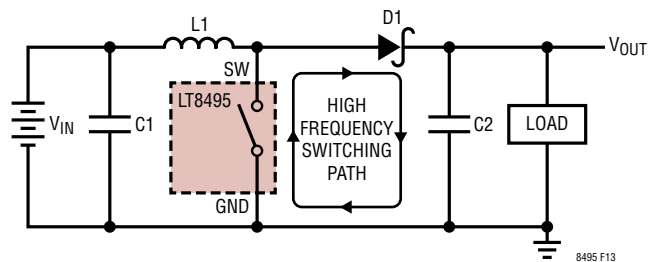
PIN NAMES	PIN #	EFFECT ON OUTPUT
FB-BIAS	1-2	Output voltage will fall to approximately 1.202V if BIAS is connected to the output.
CPOR-CWDT	5-6	No effect on output.
CWDT-RST	6-7	No effect on output.
RST-SS	7-8	No effect or output will fall below regulation.
RSTIN-SWEN	11-12	No effect on output.
SWEN-WDE	12-13	No effect on output.
WDE-GND	13-14	No effect on output.
GND-WDO	14-15	No effect on output.
WDO-WDI	15-16	No effect on output.

**Table 4. Effects of Floating Pins (TSSOP)**

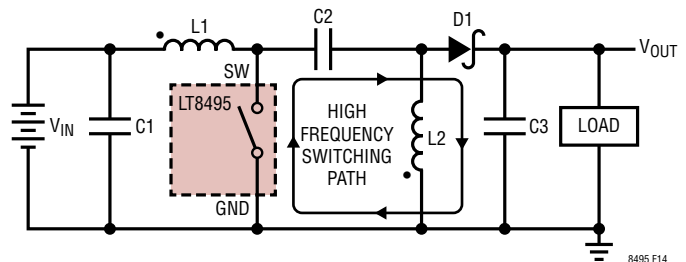
PIN NAME	PIN #	EFFECT ON OUTPUT
BIAS	1	Depending on the $V_{IN}$ voltage and the circuit topology, floating this pin will degrade device performance or the output will fall below regulation.
FB	2-3	No effect if the other FB pad is soldered.
CPOR	5	No effect on output.
CWDT	6	No effect on output.
RST	7	No effect on output.
SS	8	No effect after part has started. Can potentially lead to an increase of inrush current during start-up.
RT	10	Output may fall below regulation.
RSTIN	11	No effect on output.
SWEN	12	Enable state of the pin becomes undefined. Output will not exceed regulation voltage.
WDE	13	No effect on output.
GND	14	No effect if Exposed Pad is soldered.
WDO	15	No effect on output.
WDI	16	No effect on output.
$V_{IN}$	18	Depending on the BIAS voltage and the circuit topology, floating this pin will degrade device performance or the output will fall below regulation.
SW	10	Output will fall below regulation voltage.
Exposed Pad	21	Output maintains regulation, but potential degradation of device performance.

### Layout Hints

As with all high frequency switchers, when considering layout, care must be taken to achieve optimal electrical, thermal and noise performance. One will not get advertised performance with a careless layout. For maximum efficiency, switch rise and fall times are typically in the 5ns to 10ns range. To prevent noise, both radiated and conducted, the high speed switching current paths, shown in Figures 13 & 14, must be kept as short as possible. This is implemented in the suggested PCB layouts in Figures 15 & 16. Shortening this path will also reduce the parasitic trace inductance. At switch-off, this parasitic inductance produces a flyback spike across the LT8495 switch. When operating at higher currents and output voltages, with poor layout, this spike can generate voltages across the LT8495 that may exceed its absolute maximum rating. A ground plane should also be used under the switcher circuitry to prevent interplane coupling and overall noise. The FB components should be kept as far away as practical from the switch node. The ground for these components should be separated from the switch current path. Failure to do so can result in poor stability or subharmonic oscillation.

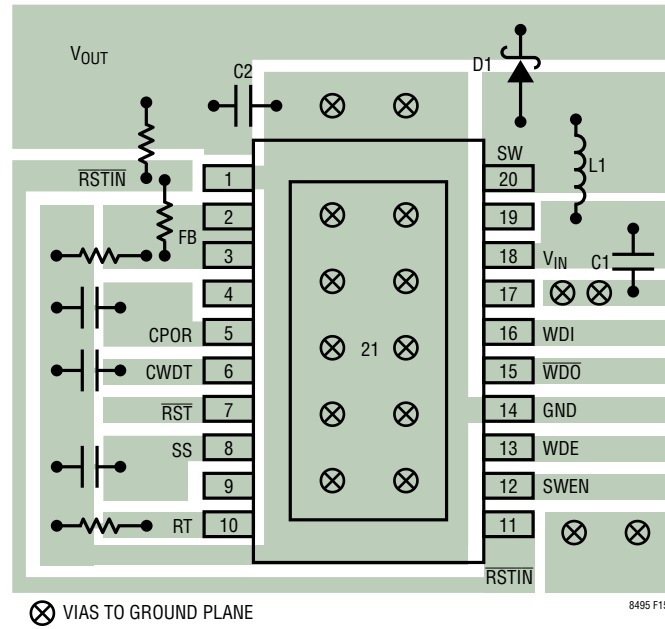


**Figure 13. High Speed Chopped Switching Path for Boost Topology**

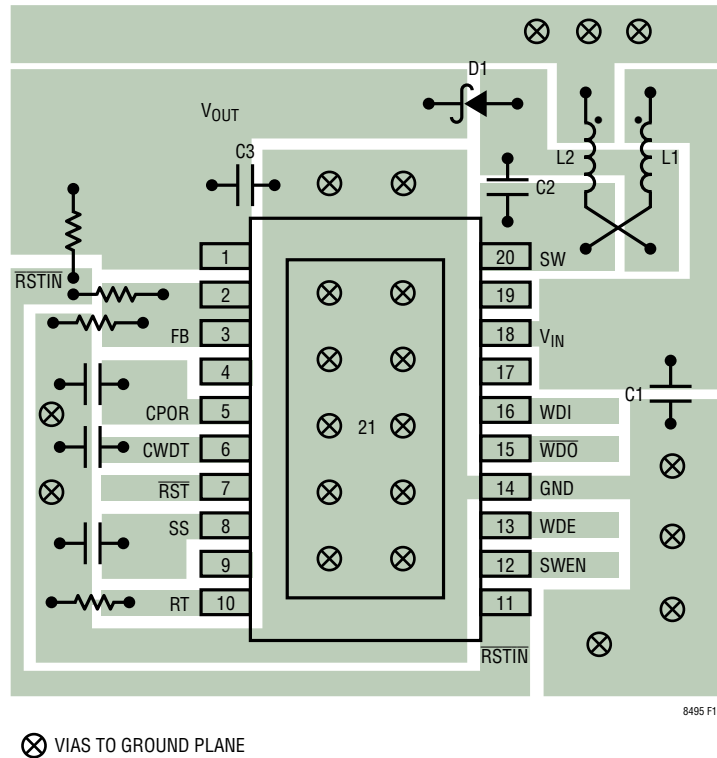


**Figure 14. High Speed Chopped Switching Path for SEPIC Topology**

APPLICATIONS INFORMATION



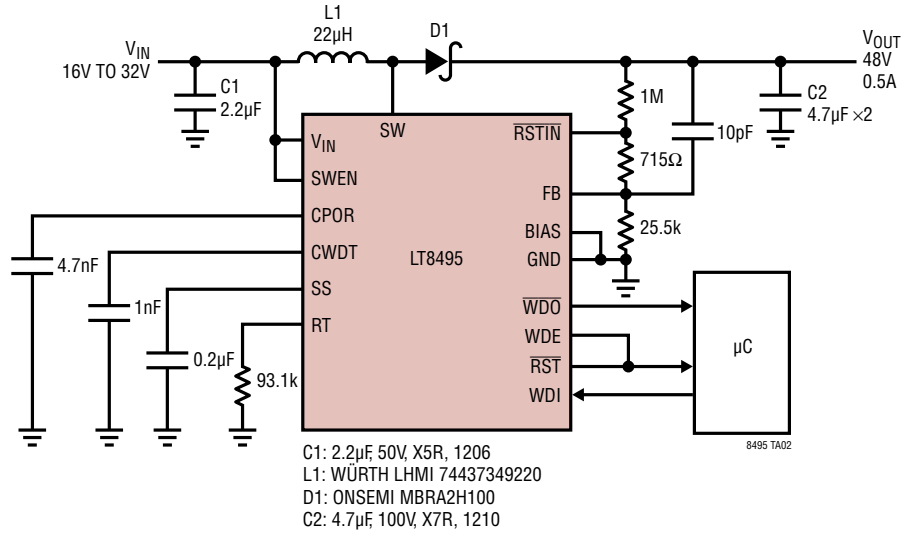
**Figure 15. Suggested Component Placement for Boost Topology. Pin 21 (Exposed Pad) Must Be Soldered Directly to the Local Ground Plane for Adequate Thermal Performance. Multiple Vias to Additional Ground Planes Will Improve Thermal Performance**



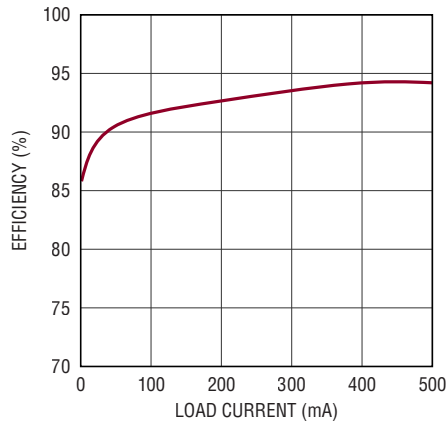
**Figure 16. Suggested Component Placement for SEPIC Topology. Pin 21 (Exposed Pad) Must Be Soldered Directly to the Local Ground Plane for Adequate Thermal Performance. Multiple Vias to Additional Ground Planes Will Improve Thermal Performance**

## TYPICAL APPLICATIONS

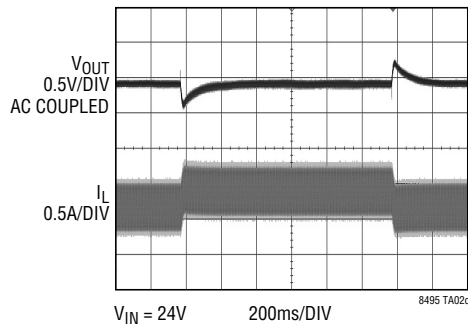
### 750kHz, 16V to 32V Input, 48V Output, 0.5A Boost Converter



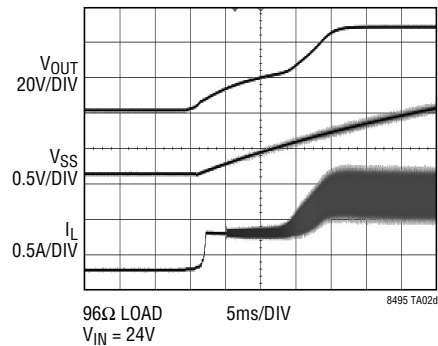
### Efficiency, $V_{IN} = 24V$



### Transient Response with 400mA to 500mA to 400mA Output Load Step



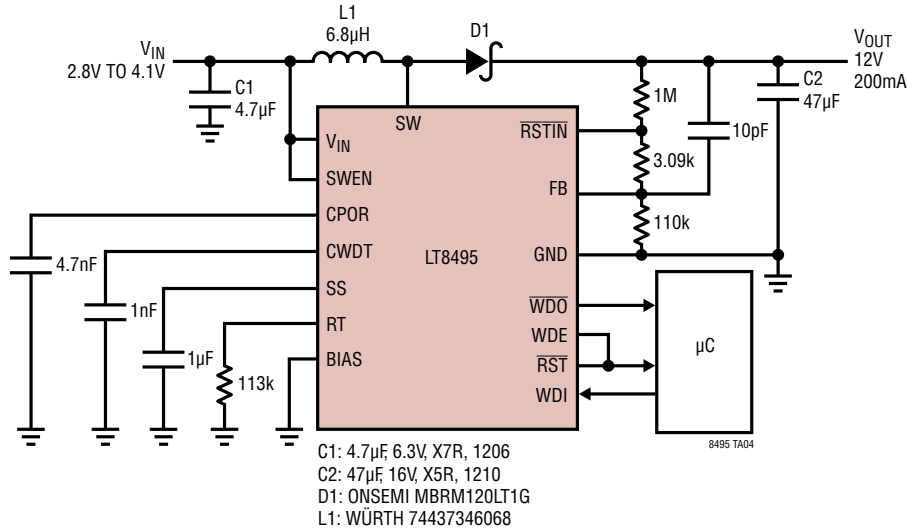
### Start-Up Waveforms



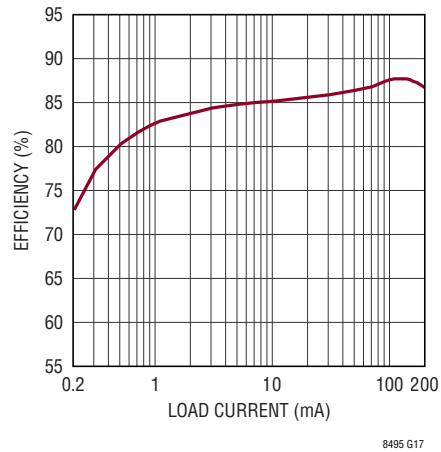


## TYPICAL APPLICATIONS

Li-Ion to 12V, Low Q Current Boost @ 650kHz



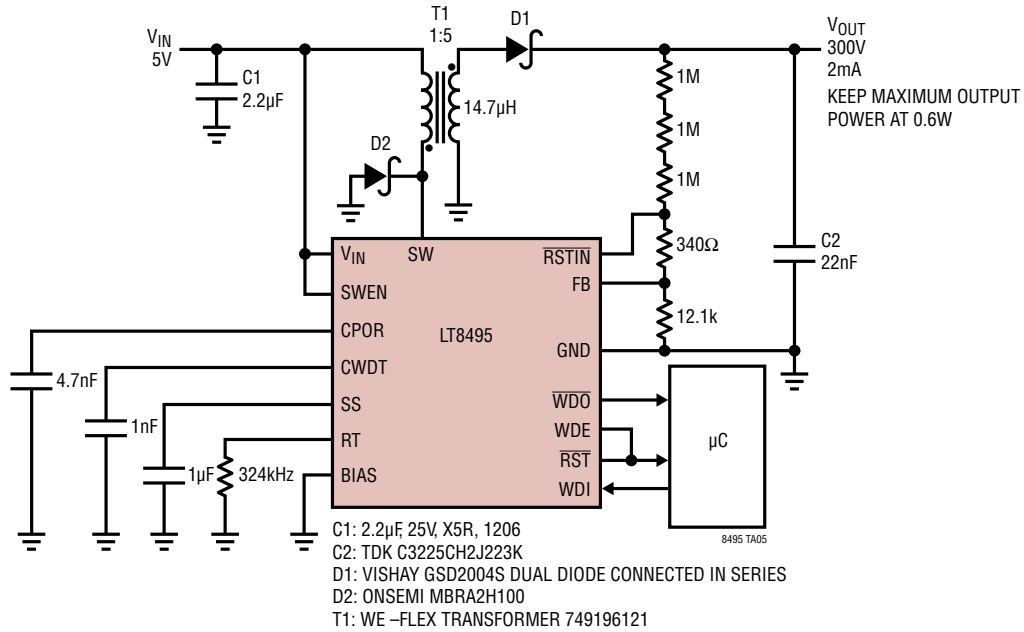
Efficiency,  $V_{IN} = 3.3V$



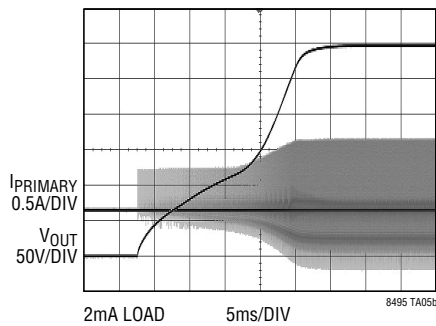
# TYPICAL APPLICATIONS

## Low Q Current, 5V to 300V, 250kHz Flyback Converter

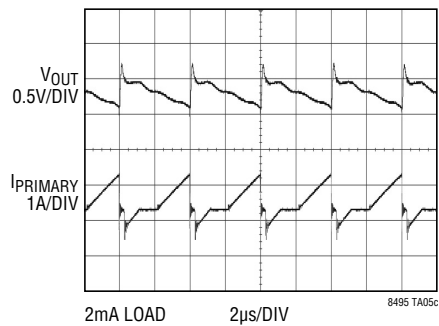
**Danger High Voltage! Operation by High Voltage Trained Personnel Only**



**Start-Up Waveforms**

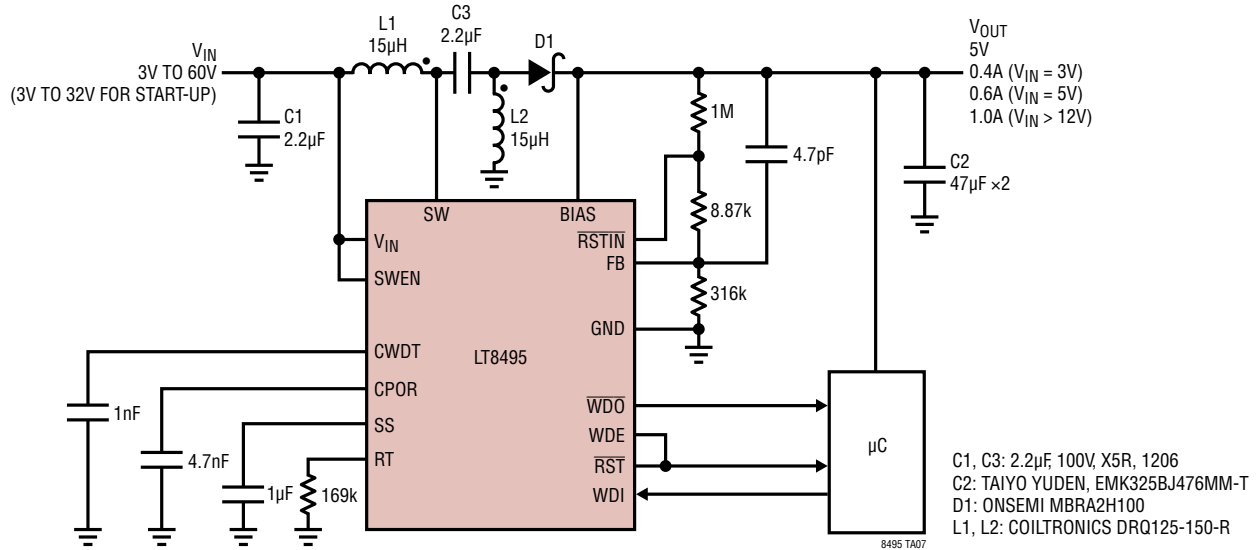


**Switching Waveforms**

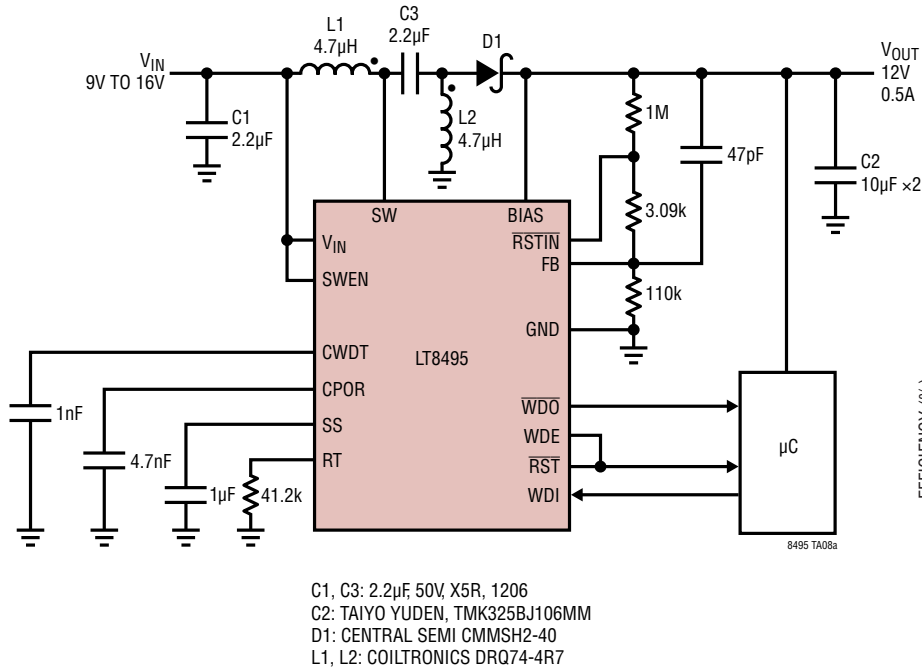


## TYPICAL APPLICATIONS

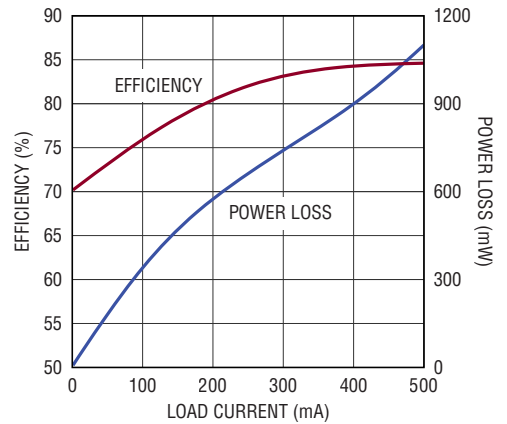
### 450kHz, 5V Output SEPIC Converter (Same as Front Page Application)



### 1.5MHz, 12V Output SEPIC Converter



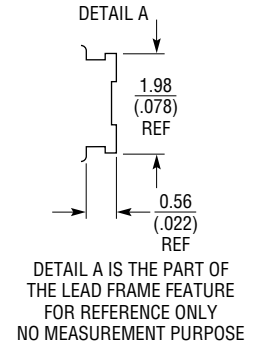
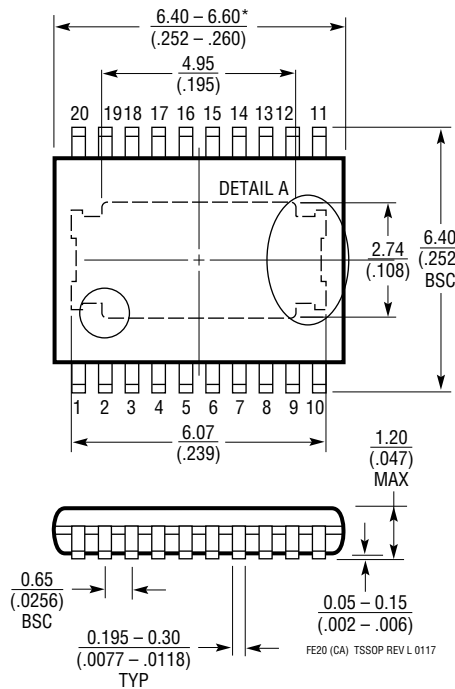
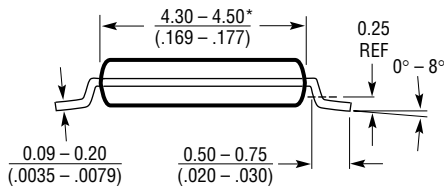
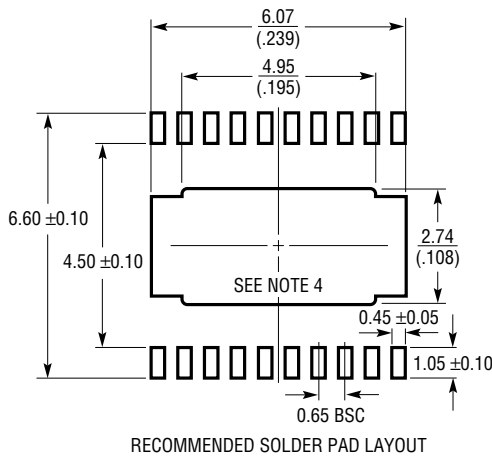
### Efficiency, $V_{IN} = 12V$



# PACKAGE DESCRIPTION

Please refer to <http://www.linear.com/product/LT8495#packaging> for the most recent package drawings.

**FE Package**  
**20-Lead Plastic TSSOP (4.4mm)**  
 (Reference LTC DWG # 05-08-1663 Rev L)  
**Exposed Pad Variation CA**



**NOTE:**

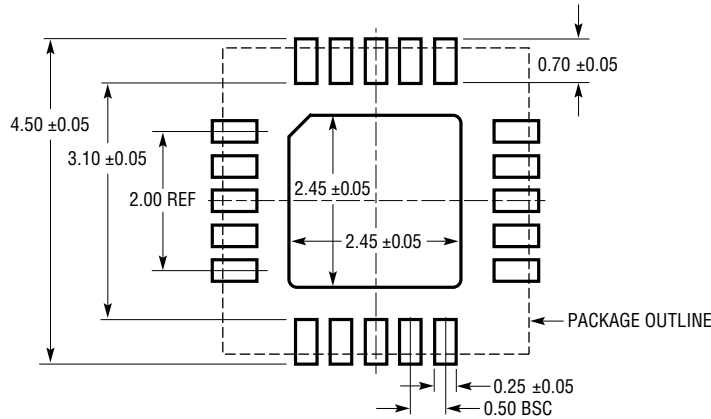
1. CONTROLLING DIMENSION: MILLIMETERS
  2. DIMENSIONS ARE IN  $\frac{\text{MILLIMETERS}}{\text{INCHES}}$
  3. DRAWING NOT TO SCALE
  4. RECOMMENDED MINIMUM PCB METAL SIZE FOR EXPOSED PAD ATTACHMENT
- \*DIMENSIONS DO NOT INCLUDE MOLD FLASH. MOLD FLASH SHALL NOT EXCEED 0.150mm (.006") PER SIDE

FE20 (CA) TSSOP REV L 0117

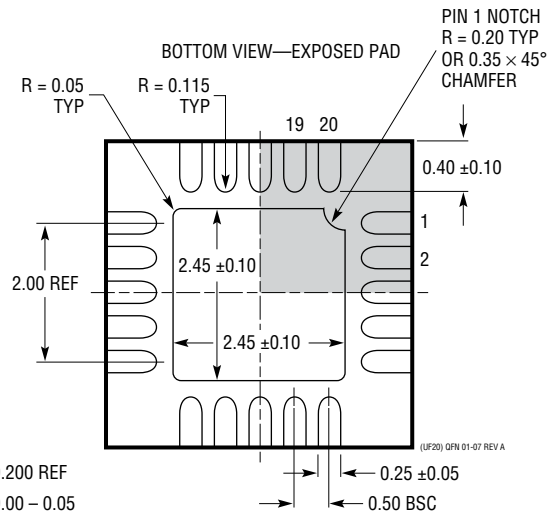
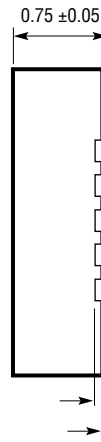
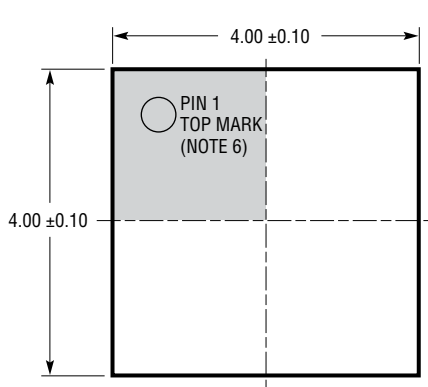
# PACKAGE DESCRIPTION

Please refer to <http://www.linear.com/product/LT8495#packaging> for the most recent package drawings.

**UF Package**  
**20-Lead Plastic QFN (4mm × 4mm)**  
 (Reference LTC DWG # 05-08-1710 Rev A)



RECOMMENDED SOLDER PAD PITCH AND DIMENSIONS  
 APPLY SOLDER MASK TO AREAS THAT ARE NOT SOLDERED



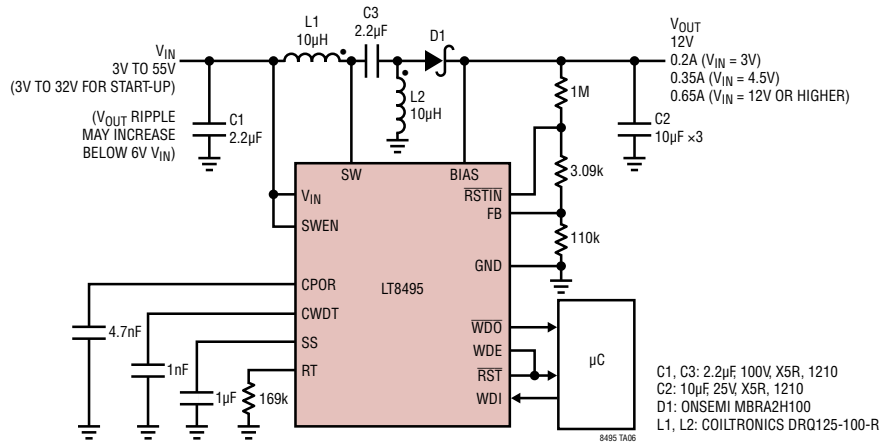
- NOTE:
1. DRAWING IS PROPOSED TO BE MADE A JEDEC PACKAGE OUTLINE MO-220 VARIATION (WGGD-1)—TO BE APPROVED
  2. DRAWING NOT TO SCALE
  3. ALL DIMENSIONS ARE IN MILLIMETERS
  4. DIMENSIONS OF EXPOSED PAD ON BOTTOM OF PACKAGE DO NOT INCLUDE MOLD FLASH. MOLD FLASH, IF PRESENT, SHALL NOT EXCEED 0.15mm ON ANY SIDE
  5. EXPOSED PAD SHALL BE SOLDER PLATED
  6. SHADED AREA IS ONLY A REFERENCE FOR PIN 1 LOCATION ON THE TOP AND BOTTOM OF PACKAGE

## REVISION HISTORY

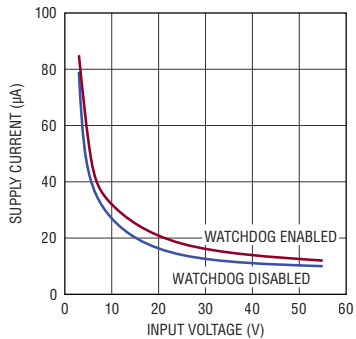
REV	DATE	DESCRIPTION	PAGE NUMBER
A	07/15	Added QFN package option.	1
		Added QFN package option and H-Grade option in TSSOP.	2, 3, 4, 9
		Clarified Quiescent Current specifications.	3
		Clarified RST Leakage Current specifications.	4
		Added Pin Current and Quiescent Current graphs.	8
		Clarified Pin Functions for QFN package.	9
		Clarified leakage current characteristics in High Temperature Considerations.	23
		Added new Typical Applications.	30
B	06/17	Clarified Input Conditions on Top Typical Application	30, 34

## TYPICAL APPLICATIONS

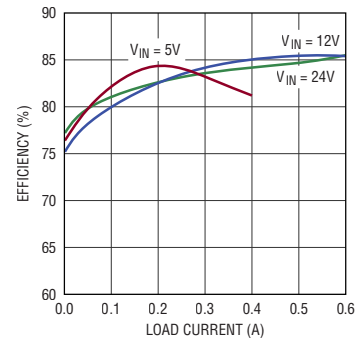
### 450kHz, Wide Input Range 12V Output SEPIC Converter



No Load Supply Current



Efficiency



## RELATED PARTS

PART NUMBER	DESCRIPTION	COMMENTS
<a href="#">LT8494</a>	70V, 2A Boost/SEPIC 1.5MHz High Efficiency DC/DC Converter	$V_{IN(MIN)} = 2.5V$ , $V_{IN(MAX)} = 32V$ , $V_{OUT(MIN)} = 70V$ , $I_Q = 9\mu A$ , $I_{SD} < 1\mu A$ , 4mm × 4mm QFN-20, TSSOP-20E Packages
<a href="#">LT3580</a>	42V, 2A Boost/Inverting 2.5MHz High Efficiency DC/DC Converter	$V_{IN}$ : 2.5V to 32V, $V_{OUT(MAX)} = \pm 40V$ , $I_Q = 1mA$ , $I_{SD} < 1\mu A$ , 3mm × 3mm DFN-8, MSOP-8E Packages
<a href="#">LT8580</a>	65V, 1A Boost/Inverting DC/DC Converter	$V_{IN}$ : 2.55V to 40V, $V_{OUT(MAX)} = \pm 60V$ , $I_Q = 1.2mA$ , $I_{SD} < 1\mu A$ , 3mm × 3mm DFN-8, MSOP-8E Packages
<a href="#">LT8570/LT8570-1</a>	65V, 500mA/250mA Boost/Inverting DC/DC Converter	$V_{IN(MIN)} = 2.55V$ , $V_{IN(MAX)} = 40V$ , $V_{OUT(MIN)} = \pm 60V$ , $I_Q = 1.2mA$ , $I_{SD} < 1\mu A$ , 3 × 3 DFN-8, MSOP-8E Package
<a href="#">LT8582</a>	40V, Dual 3A, 2.5MHz High Efficiency Boost Converter	$V_{IN}$ : 2.5V to 40V, $V_{OUT(MAX)} = \pm 40V$ , $I_Q = 2.8\mu A$ , $I_{SD} < 1\mu A$ , 7mm × 4mm DFN-24 Package
<a href="#">LT8471</a>	40V, Dual 3A, Multitopology High Efficiency DC/DC Converter	$V_{IN}$ : 2.6V to 50V, $V_{OUT(MAX)} = \pm 45V$ , $I_Q = 2.4mA$ , $I_{SD} < 1\mu A$ , TSOP-20E Package
<a href="#">LT3581</a>	40V, 3.3A, 2.5MHz High Efficiency Boost Converter	$V_{IN}$ : 2.5V to 40V, $V_{OUT(MAX)} = \pm 40V$ , $I_Q = 1mA$ , $I_{SD} < 1\mu A$ , 4mm × 3mm DFN-14, MSOP-16E Packages
<a href="#">LT8582</a>	40V, Dual 3A Boost, Inverter, SEPIC, 2.5MHz High Efficiency Boost Converter	$V_{IN}$ : 2.5V to 40V, $V_{OUT(MAX)} = \pm 40V$ , $I_Q = 2.1mA$ , $I_{SD} < 1\mu A$ , 7mm × 4mm DFN-24 Package
<a href="#">LT3579/LT3579-1</a>	40V, 3.3A Boost, Inverter, SEPIC, 2.5MHz High Efficiency Boost Converter	$V_{IN}$ : 2.5V to 40V, $V_{OUT(MAX)} = \pm 40V$ , $I_Q = 1mA$ , $I_{SD} < 1\mu A$ , 4mm × 5mm QFN-20, TSSOP-20E Packages

8495fb

## Looking for pricing, stock, or lifecycle information?

Click below to explore more details on WIN SOURCE:

 [View LT8495HFE#PBF on WIN SOURCE](#)

 [Analog Devices Inc. Information](#)

## Optimize Your Supply Chain with WIN SOURCE Solutions

-  Global Sourcing Solution
-  Obsolete Management
-  Cost Control Management
-  Shortage Management
-  Alternative Solution
-  Excess Inventory Management