

Three-channel, Single-phase Power/Energy IC

Features

- Energy Linearity: $\pm 0.1\%$ of Reading over 1000:1 Dynamic Range
- On-chip Functions:
 - Voltage and Current Measurement
 - Active, Reactive, and Apparent Power/Energy
 - RMS Voltage and Current Calculations
 - Current Fault and Voltage Sag Detection
 - Calibration
 - Phase Compensation
 - Temperature Sensor
 - Energy Pulse Outputs
- Meets Accuracy Spec for IEC, ANSI, & JIS
- Low Power Consumption
- Tamper Detection and Correction
- Ground-referenced Inputs with Single Supply
- On-chip 2.5 V Reference (40 ppm / °C typ.)
- Power Supply Monitor Function
- Three-wire Serial Interface to Microcontroller or E²PROM
- Power Supply Configurations
GND: 0 V, VA+: +5 V, VD+: +3.3 V to +5 V

Description

The CS5464 is a watt-hour meter on a chip. It measures line voltage and current and calculates active, reactive, apparent power, energy, power factor, and RMS voltage and current.

There are two separate inputs to measure line, ground, and/or neutral current enabling the meter to detect tampering and to continue operating. An internal RMS voltage reference can be used if voltage measurement is disabled by tampering.

Four $\Delta\Sigma$ analog-to-digital converters are used to measure voltage, two currents, and temperature.

The CS5464 is designed to interface to a variety of voltage and current sensors.

Additional features include system-level calibration, voltage sag and current fault detection, peak detection, phase compensation, and energy pulse outputs.

ORDERING INFORMATION

See [Page 44](#).

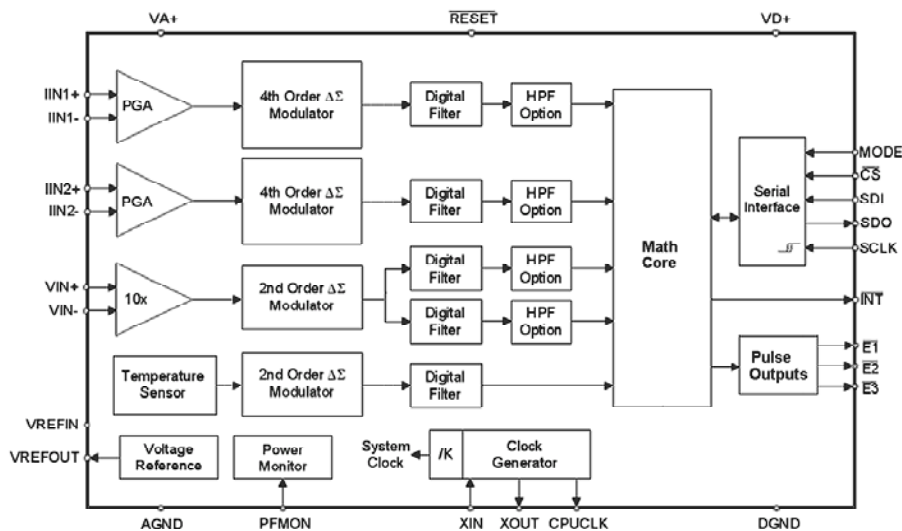

TABLE OF CONTENTS

1. Overview	5
2. Pin Description	6
Clock Generator	6
Control Pins and Serial Data I/O	6
Analog Inputs/Outputs	6
Power Connections	6
Other Pins	6
3. Characteristics & Specifications	7
Recommended Operating Conditions	7
Analog Characteristics	7
Accuracy	7
Analog Inputs (All Inputs)	7
Analog Inputs (Current Inputs)	7
Analog Inputs (Voltage Inputs)	8
Temperature	8
Power Supplies	8
Voltage Reference	9
Reference Output	9
Reference Input	9
Digital Characteristics	10
Master Clock Characteristics	10
Filter Characteristics	10
Input/Output Characteristics	10
Switching Characteristics	11
Start-up	11
Serial Port Timing	11
SDI Timing	11
SDO Timing	11
E2PROM mode Timing	11
E1, E2, and E3 Timing	13
Absolute Maximum Ratings	13
4. Signal Path Description	14
4.1 Analog-to-Digital Converters	14
4.2 Decimation Filters	14
4.3 Phase Compensation	14
4.4 DC Offset and Gain Correction	15
4.5 High-pass Filters	15
4.6 Low-Rate Calculations	15
4.7 RMS Results	15
4.8 Power and Energy Results	16
4.9 Peak Voltage and Current	16
4.10 Power Offset	16
5. Pin Descriptions	17
5.1 Analog Pins	17
5.1.1 Voltage Inputs	17
5.1.2 Current1 and Current2 Inputs	17
5.1.3 Power Fail Monitor Input	17

5.1.4 Voltage Reference Input	17
5.1.5 Voltage Reference Output	17
5.1.6 Crystal Oscillator	17
5.2 Digital Pins	17
5.2.1 Reset Input	17
5.2.2 CPU Clock Output	17
5.2.3 Interrupt Output	17
5.2.4 Energy Pulse Outputs	17
5.2.5 Serial Interface	18
6. Setting Up the CS5464	19
6.1 Clock Divider	19
6.2 CPU Clock Inversion	19
6.3 Interrupt Pin Behavior	19
6.4 Current Input Gain Ranges	19
6.5 High-pass Filters	19
6.6 Cycle Count	19
6.7 Energy Pulse Outputs	19
6.8 No Load Threshold	20
6.9 Energy Pulse Width	20
6.10 Energy Pulse Rate	20
6.11 Voltage Sag/Current Fault Detection	20
6.12 Epsilon	21
6.13 Temperature Measurement	21
7. Using the CS5464	22
7.1 Initialization	22
7.2 Power-down States	22
7.3 Tamper Detection and Correction	22
7.4 Command Interface	23
7.5 Register Paging	23
7.6 Commands	24
8. Register Descriptions	28
8.1 Page Register	28
8.2 Page 0 Registers	28
8.3 Page 1 Registers	33
8.4 Page 2 Registers	38
9. System Calibration	39
9.1 Calibration	39
9.1.1 Offset Calibration	39
9.1.1.1 DC Offset Calibration	39
9.1.1.2 AC Offset Calibration	39
9.1.2 Gain Calibration	40
9.1.2.1 AC Gain Calibration	40
9.1.2.2 DC Gain Calibration	40
9.1.3 Calibration Order	40

9.1.4 Temperature Sensor Calibration	40
9.1.4.1 Temperature Offset Calibration	40
9.1.4.2 Temperature Gain Calibration	40
10. E2PROM Operation	41
10.1 E ² PROM Configuration	41
10.2 E ² PROM Code	41
10.3 Which E ² PROMs Can Be Used?	41
11. Basic Application Circuits	42
12. Package Dimensions	43
13. Ordering Information	44
14. Environmental, Manufacturing, & Handling Information	44
15. Revision History	45

LIST OF FIGURES

Figure 1. CS5464 Read and Write Timing Diagrams	12
Figure 2. Timing Diagram for $\overline{E1}$, $\overline{E2}$, and $\overline{E3}$	13
Figure 3. Signal Flow for V1, I1, P1, Q1 Measurements	14
Figure 4. Signal Flow for V2, I2, P2, Q2 Measurements	14
Figure 5. Low-rate Calculations	16
Figure 6. Oscillator Connections	17
Figure 7. Sag and Fault Detect	21
Figure 8. Energy Channel Selection	22
Figure 9. Fixed RMS Voltage Selection	22
Figure 10. Calibration Data Flow	39
Figure 11. System Calibration of Offset	39
Figure 12. System Calibration of Gain	40
Figure 13. Typical Interface of E ² PROM to CS5464	41
Figure 14. Typical Connection Diagram	42

LIST OF TABLES

Table 1. Interrupt Configuration	19
Table 2. Current Input Gain Ranges	19
Table 3. High-pass Filter Configuration	19
Table 4. $\overline{E2}$ Pin Configuration	19
Table 5. $\overline{E3}$ Pin Configuration	20
Table 6. $\overline{E1}$ / $\overline{E2}$ Modes	20
Table 7. $\overline{E3}$ Pin with E1MODE enabled	20

1. OVERVIEW

The CS5464 is a CMOS power measurement integrated circuit utilizing four $\Delta\Sigma$ analog-to-digital converters to measure line voltage, temperature, and current from up to two sources. It calculates active, reactive, and apparent power as well as RMS and peak voltage and current. It handles other system-related functions, such as pulse output conversion, voltage sag, current fault, voltage zero crossing, line frequency, and tamper detection.

The CS5464 is optimized to interface to current transformers or shunt resistors for current measurement, and to a resistive divider or voltage transformer for voltage measurement. Two full-scale ranges are provided on the current inputs to accommodate both types of current sensors. The second current channel can be used for tamper detection or as a second current input. The CS5464's three differential inputs have a common-mode input range from analog ground (AGND) to the positive analog supply (VA+).

An additional analog input (PFMON) is provided to allow the application to determine when a power failure is in progress. By monitoring the unregulated power supply, the application can take any required action when a power loss occurs.

An on-chip voltage reference (nominally 2.5 volts) is generated and provided at analog output, VREFOUT. This reference can be supplied to the chip by connecting it to the reference voltage input, VREFIN. Alternatively, an external voltage reference can be supplied to the reference input.

Three digital outputs ($\overline{E1}$, $\overline{E2}$, $\overline{E3}$) provide a variety of output signals and, depending on the mode selected, provide energy pulses, power failure indication, or other choices.

The CS5464 includes a three-wire serial host interface to an external microcontroller or serial E²PROM. Signals include serial data input (SDI), serial data output (SDO), serial clock (SCLK), and optionally, a chip select (\overline{CS}), which allows the CS5464 to share the SDO signal with other devices. A MODE input is used to control whether an E²PROM will be used instead of a host microcontroller.

2. PIN DESCRIPTION

Crystal Out	XOUT	□ 1 ●	28 □	XIN	Crystal In
CPU Clock Output	CPUCLK	□ 2	27 □	SDI	Serial Data Input
Positive Digital Supply	VD+	□ 3	26 □	E2	Energy Output 2
Digital Ground	DGND	□ 4	25 □	E1	Energy Output 1
Serial Clock	SCLK	□ 5	24 □	INT	Interrupt
Serial Data Output	SDO	□ 6	23 □	RESET	Reset
Chip Select	CS	□ 7	22 □	E3	Energy Output 3
Mode Select	MODE	□ 8	21 □	PFMON	Power Fail Monitor
Differential Voltage Input	VIN+	□ 9	20 □	IIN1+	Differential Current Input
Differential Voltage Input	VIN-	□ 10	19 □	IIN1-	Differential Current Input
Voltage Reference Output	VREFOUT	□ 11	18 □	VA+	Positive Analog Supply
Voltage Reference Input	VREFIN	□ 12	17 □	AGND	Analog Ground
Factory Test	TEST1	□ 13	16 □	IIN2+	Differential Current Input
Factory Test	TEST2	□ 14	15 □	IIN2-	Differential Current Input

Clock Generator

Crystal Out	1,28	XOUT, XIN — Connect to an external quartz crystal. Alternatively, an external clock can be supplied to the XIN pin to provide the system clock for the device.
Crystal In		
CPU Clock Output	2	CPUCLK - Logic-level output from crystal oscillator. Can be used to clock an external CPU.

Control Pins and Serial Data I/O

Serial Clock	5	SCLK — Clocks serial data from the SDI pin and to the SDO pin when \overline{CS} is low. SCLK is a Schmitt-trigger input when MODE is low and a driven output when MODE is high.
Serial Data Output	6	SDO — Serial data output. Data is clocked out by SCLK.
Chip Select	7	CS — An input that enables the serial interface when MODE is low and a driven output when MODE is high.
Mode Select	8	MODE — High selects external E ² PROM, Low selects external microcontroller. MODE includes a weak internal pull-down and therefore selects microcontroller mode if not connected.
Energy Outputs	22, 25, 26	E3, E1, E2 — Primarily active-low energy pulse outputs. These can be programmed to output other conditions.
Reset	23	RESET — An active-low Schmitt-trigger input used to reset the chip.
Interrupt	24	INT — Active-low output, indicates that an enabled condition has occurred.
Serial Data Input	27	SDI — Serial data input. Data is clocked in by SCLK.

Analog Inputs/Outputs

Differential Voltage Inputs	9,10	VIN+, VIN- — Differential analog inputs for the voltage channel.
Differential Current Inputs	20,19, 16,15	IIN1+, IIN1-, IIN2+, IIN2- — Differential analog inputs for the current channels.
Power Fail Monitor	21	PFMON — Used to monitor the unregulated power supply via a resistive divider. If the PFMON voltage drops below its low limit, the low-supply detect (LSD) bit is set in the <i>Status</i> register.
Voltage Reference Output	11	VREFOUT — The on-chip voltage reference output. Nominally 2.5 V, referenced to AGND.
Voltage Reference Input	12	VREFIN — The voltage reference input. Can be connected to VREFOUT or external 2.5 V reference.

Power Connections

Positive Digital Supply	3	VD+ — The positive digital supply.
Digital Ground	4	DGND — Digital ground.
Positive Analog Supply	18	VA+ — The positive analog supply.
Analog Ground	17	AGND — Analog ground.

Other Pins

Test1, Test2	13,14	NC — Factory use only. Connect to AGND.
---------------------	-------	--

3. CHARACTERISTICS & SPECIFICATIONS

RECOMMENDED OPERATING CONDITIONS

Parameter	Symbol	Min	Typ	Max	Unit
Positive Digital Power Supply	VD+	3.135	5.0	5.25	V
Positive Analog Power Supply	VA+	4.75	5.0	5.25	V
Voltage Reference	VREFIN	-	2.5	-	V
Specified Temperature Range	T _A	-40	-	+85	°C

ANALOG CHARACTERISTICS

- Min / Max characteristics and specifications are guaranteed over all [Recommended Operating Conditions](#).
- Typical characteristics and specifications are measured at nominal supply voltages and T_A = 25 °C.
- VA+ = VD+ = 5 V ±5%; AGND = DGND = 0 V; VREFIN = +2.5 V. All voltages with respect to 0 V.
- DCLK = 4.096 MHz.

Parameter	Symbol	Min	Typ	Max	Unit
Accuracy					
Active Power (Note 1)	All Gain Ranges Input Range 0.1% - 100% P _{Active}	-	±0.1	-	%
Reactive Power (Note 1 and 2)	All Gain Ranges Input Range 0.1% - 100% Q _{Avg}	-	±0.2	-	%
Power Factor (Note 1 and 2)	All Gain Ranges Input Range 1.0% - 100%	-	±0.2	-	%
	Input Range 0.1% - 1.0%	-	±0.27	-	%
Current RMS (Note 1)	All Gain Ranges Input Range 1.0% - 100%	-	±0.1	-	%
	Input Range 0.1% - 1.0%	-	±0.17	-	%
Voltage RMS (Note 1)	All Gain Ranges Input Range 5% - 100% V _{RMS}	-	±0.1	-	%
Analog Inputs (All Inputs)					
Common Mode Rejection	(DC, 50, 60 Hz) CMRR	80	-	-	dB
Common Mode + Signal		-0.25	-	VA+	V
Analog Inputs (Current Inputs)					
Differential Input Range [(IIN+) - (IIN-)]	(Gain = 10)	-	500	-	mV _{P-P}
	(Gain = 50)	-	100	-	mV _{P-P}
Total Harmonic Distortion	(Gain = 50) THD	80	94	-	dB
Crosstalk from Voltage Input at Full Scale	(50, 60 Hz)	-	-115	-	dB
Input Capacitance	IC	-	27	-	pF
Effective Input Impedance	EII	30	-	-	kΩ
Noise (Referred to Input)	(Gain = 10)	-	-	22.5	μV _{rms}
	(Gain = 50)	-	-	4.5	μV _{rms}
Offset Drift (Without the High-pass Filter)	OD	-	4.0	-	μV/°C
Gain Error	(Note 3) GE	-	±0.4	-	%

Notes: 1. Applies when the HPF option is enabled.

2. Applies when the line frequency is equal to the product of the output word rate (OWR) and the value of *Epsilon*.

ANALOG CHARACTERISTICS (Continued)

Parameter	Symbol	Min	Typ	Max	Unit	
Analog Inputs (Voltage Inputs)						
Differential Input Range [(VIN+) – (VIN-)]	VIN	-	500	-	mV _{P-P}	
Total Harmonic Distortion	THD	65	75	-	dB	
Crosstalk from Current Inputs at Full Scale (50, 60 Hz)		-	-70	-	dB	
Input Capacitance All Gain Ranges	IC	-	2.0	-	pF	
Effective Input Impedance	EII	2	-	-	MΩ	
Noise (Referred to Input)	N _V	-	-	140	μV _{rms}	
Offset Drift (Without the High-pass Filter)	OD	-	16.0	-	μV/°C	
Gain Error (Note 3)	GE	-	±3.0		%	
Temperature						
Temperature Accuracy	T	-	±5	-	°C	
Power Supplies						
Power Supply Currents (Active State)	I _{A+}	PSCA	-	1.5	-	mA
	I _{D+} (VA+ = VD+ = 5 V)	PSCD	-	3.5	-	mA
	I _{D+} (VA+ = 5 V, VD+ = 3.3 V)	PSCD	-	2.3	-	mA
Power Consumption (Note 4)	Active State (VA+ = VD+ = 5 V)	PC	-	25	33	mW
	Active State (VA+ = 5 V, VD+ = 3.3 V)		-	15	20	mW
	Stand-by State		-	7	-	mW
	Sleep State		-	10	-	uW
Power Supply Rejection Ratio (50, 60 Hz) (Note 5)	Voltage	PSRR	48	55	-	dB
	Current (Gain = 50x)		68	75	-	dB
	Current (Gain = 10x)		60	65	-	dB
PFMON Low-voltage Trigger Threshold (Note 6)		PMLO	2.3	2.45	-	V
PFMON High-voltage Power-on Trip Point (Note 7)		PMHI	-	2.55	2.7	V

- Notes:
- Applies before system calibration.
 - All outputs unloaded. All inputs CMOS level.
 - Measurement method for PSRR: VREFIN tied to VREFOUT, VA+ = VD+ = 5 V, a 150 mV (zero-to-peak) (60 Hz) sinewave is imposed onto the +5 V DC supply voltage at VA+ and VD+ pins. The "+" and "-" input pins of both input channels are shorted to AGND. The CS5464 is then commanded to continuous conversion acquisition mode, and digital output data is collected for the channel under test. The (zero-to-peak) value of the digital sinusoidal output signal is determined, and this value is converted into the (zero-to-peak) value of the sinusoidal voltage (measured in mV) that would need to be applied at the channel's inputs, in order to cause the same digital sinusoidal output. This voltage is then defined as V_{eq}. PSRR is (in dB):

$$PSRR = 20 \cdot \log \left[\frac{150}{V_{eq}} \right]$$

- When voltage level on PFMON is sagging, and LSD bit = 0, the voltage at which LSD is set to 1.
- If the LSD bit has been set to 1 (because PFMON voltage fell below PMLO), this is the voltage level on PFMON at which the LSD bit can be permanently reset back to 0.

VOLTAGE REFERENCE

Parameter	Symbol	Min	Typ	Max	Unit
Reference Output					
Output Voltage	VREFOUT	+2.4	+2.5	+2.6	V
Temperature Coefficient (Note 8)	TC_{VREF}	-	40	-	ppm/°C
Load Regulation (Note 9)	ΔV_R	-	6	10	mV
Reference Input					
Input Voltage Range	VREFIN	+2.4	+2.5	+2.6	V
Input Capacitance		-	4	-	pF
Input CVF Current		-	100	-	nA

Notes: 8. The voltage at VREFOUT is measured across the temperature range. From these measurements the following formula is used to calculate the VREFOUT temperature coefficient:

$$TC_{VREF} = \left(\frac{VREFOUT_{MAX} - VREFOUT_{MIN}}{VREFOUT_{AVG}} \right) \left(\frac{1}{T_{A,MAX} - T_{A,MIN}} \right) \left(1.0 \times 10^6 \right)$$

9. Specified at maximum recommended output of 1 μ A, source or sink.

DIGITAL CHARACTERISTICS

- Min / Max characteristics and specifications are guaranteed over all [Recommended Operating Conditions](#).
- Typical characteristics and specifications are measured at nominal supply voltages and $T_A = 25\text{ }^\circ\text{C}$.
- $V_{A+} = V_{D+} = 5V \pm 5\%$; $AGND = DGND = 0V$. All voltages with respect to 0 V.
- $DCLK = 4.096\text{ MHz}$.

Parameter	Symbol	Min	Typ	Max	Unit
Master Clock Characteristics					
Master Clock Frequency Internal Gate Oscillator (Note 11)	DCLK	2.5	4.096	20	MHz
Master Clock Duty Cycle		40	-	60	%
CPUCLK Duty Cycle (Note 12 and 13)		40	-	60	%
Filter Characteristics					
Phase Compensation Range (60 Hz, OWR = 4000 Hz)		-5.4	-	+5.4	°
Input Sampling Rate DCLK = MCLK/K		-	DCLK/8	-	Hz
Digital Filter Output Word Rate (Both channels)	OWR	-	DCLK/1024	-	Hz
High-pass Filter Corner Frequency -3 dB		-	0.5	-	Hz
Full-scale DC Calibration Range (Referred to Input) (Note 14)	FSCR	25	-	100	%FS
Channel-to-channel Time-shift Error (Note 15)			1.0		µs
Input/Output Characteristics					
High-level Input Voltage All Pins Except XIN and SCLK and $\overline{\text{RESET}}$ XIN SCLK and $\overline{\text{RESET}}$	V_{IH}	0.6 V_{D+} (V_{D+}) - 0.5 0.8 V_{D+}	- - -	- - -	V V V
Low-level Input Voltage ($V_D = 5V$) All Pins Except XIN and SCLK and $\overline{\text{RESET}}$ XIN SCLK and $\overline{\text{RESET}}$	V_{IL}	- - -	- - -	0.8 1.5 0.2 V_{D+}	V V V
Low-level Input Voltage ($V_D = 3.3V$) All Pins Except XIN and SCLK and $\overline{\text{RESET}}$ XIN SCLK and $\overline{\text{RESET}}$	V_{IL}	- - -	- - -	0.48 0.3 0.2 V_{D+}	V V V
High-level Output Voltage $I_{out} = +5\text{ mA}$	V_{OH}	(V_{D+}) - 1.0	-	-	V
Low-level Output Voltage $I_{out} = -5\text{ mA}$ ($V_D = +5V$) $I_{out} = -2.5\text{ mA}$ ($V_D = +3.3V$)	V_{OL}	- -	- -	0.4 0.4	V V
Input Leakage Current (Note 16)	I_{in}	-	±1	±10	µA
3-state Leakage Current	I_{OZ}	-	-	±10	µA
Digital Output Pin Capacitance	C_{out}	-	5	-	pF

Notes: 10. All measurements performed under static conditions.

11. If a crystal is used, XIN frequency must remain between 2.5 MHz - 5.0 MHz. If an external oscillator is used, XIN frequency range is 2.5 MHz - 20 MHz, but K must be set so that MCLK is between 2.5 MHz - 5.0 MHz.
12. If external MCLK is used, the duty cycle must be between 45% and 55% to maintain this specification.
13. The frequency of CPUCLK is equal to MCLK.
14. The minimum FSCR is limited by the maximum allowed gain register value. The maximum FSCR is limited by the full-scale signal applied to the input.
15. Configuration register (*Config*) bits PC[6:0] are set to "0000000".
16. The MODE pin is pulled low by an internal resistor.

SWITCHING CHARACTERISTICS

- Min / Max characteristics and specifications are guaranteed over all [Recommended Operating Conditions](#).
- Typical characteristics and specifications are measured at nominal supply voltages and TA = 25 °C.
- VA+ = 5 V ±5% VD+ = 3.3 V ±5% or 5 V ±5%; AGND = DGND = 0 V. All voltages with respect to 0 V.
- Logic Levels: Logic 0 = 0 V, Logic 1 = VD+.

Parameter	Symbol	Min	Typ	Max	Unit
Rise Times (Note 17)	Any Digital Output t_{rise}	-	-	1.0	μ s
		-	50	-	ns
Fall Times (Note 17)	Any Digital Output t_{fall}	-	-	1.0	μ s
		-	50	-	ns
Start-up					
Oscillator Start-up Time	XTAL = 4.096 MHz (Note 11) t_{ost}	-	60	-	ms
Serial Port Timing					
Serial Clock Frequency	SCLK	-	-	2	MHz
Serial Clock	Pulse Width High t_1	200	-	-	ns
	Pulse Width Low t_2	200	-	-	ns
SDI Timing					
CS Falling to SCLK Rising	t_3	50	-	-	ns
Data Set-up Time Prior to SCLK Rising	t_4	50	-	-	ns
Data Hold Time After SCLK Rising	t_5	100	-	-	ns
SDO Timing					
CS Falling to SDO Driving	t_6	-	20	50	ns
SCLK Falling to New Data Bit (hold time)	t_7	-	20	50	ns
CS Rising to SDO Hi-Z	t_8	-	20	50	ns
E²PROM mode Timing					
Serial Clock	Pulse Width Low t_9		8		DCLK
	Pulse Width High t_{10}		8		DCLK
MODE setup time to RESET Rising	t_{11}	50			ns
RESET rising to CS falling	t_{12}	48			DCLK
CS falling to SCLK rising	t_{13}	100	8		DCLK
SCLK falling to CS rising	t_{14}		16		DCLK
CS rising to driving MODE low	t_{15}	50			ns
SDO setup time to SCLK rising	t_{16}	100			ns

Notes: 17. Specified using 10% and 90% points on waveform of interest. Output loaded with 50 pF.

18. Oscillator start-up time varies with crystal parameters. This specification does not apply when using an external clock source.

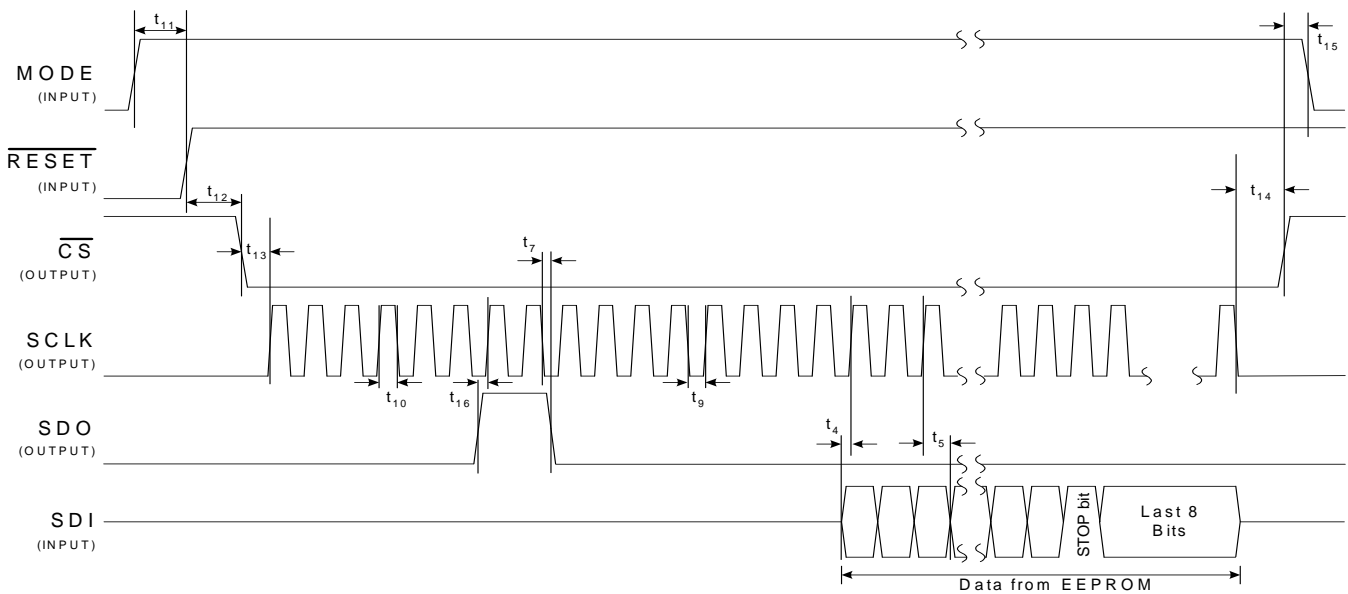
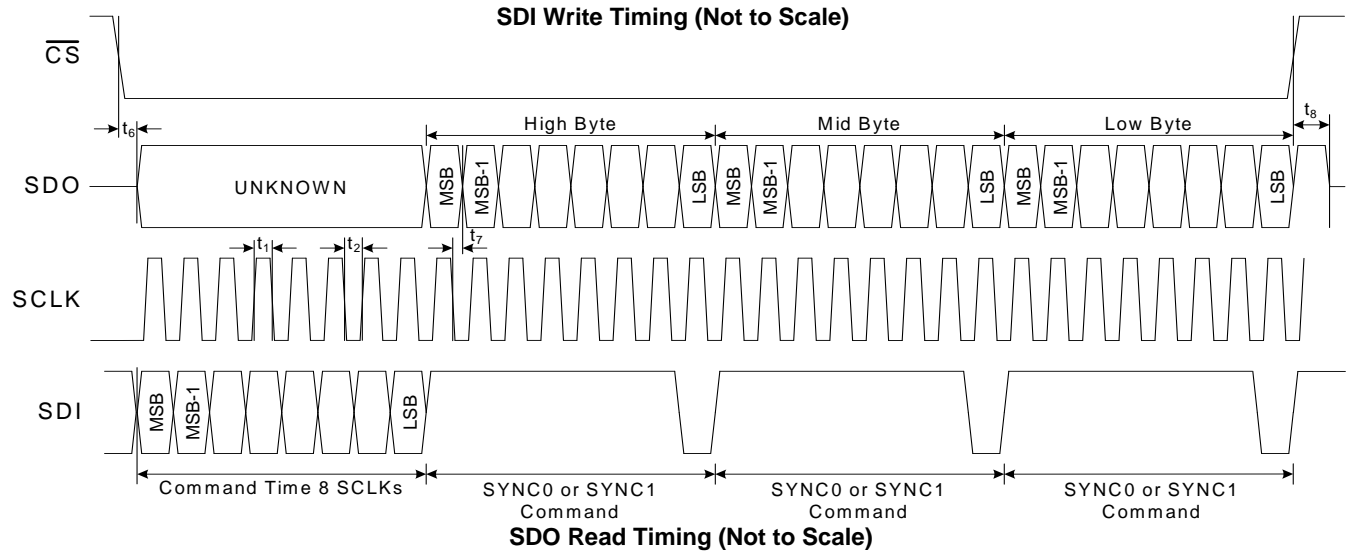
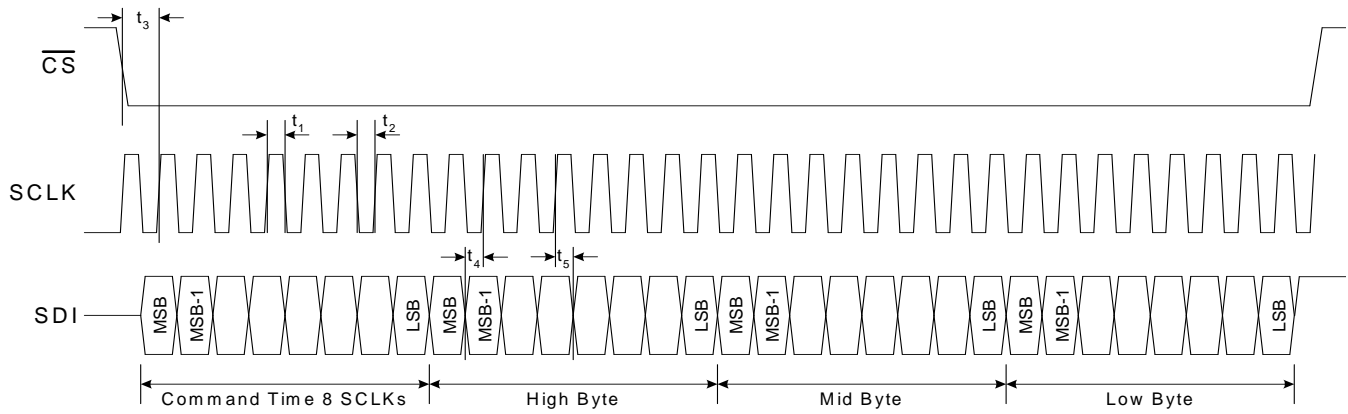
Figure 1. CS5464 Read and Write Timing Diagrams

SWITCHING CHARACTERISTICS (Continued)

Parameter	Symbol	Min	Typ	Max	Unit
$\overline{E1}$, $\overline{E2}$, and $\overline{E3}$ Timing (Note 19 and 20)					
Period	t_{period}	500	-	-	μs
Pulse Width	t_{pw}	244	-	-	μs
Rising Edge to Falling Edge	t_3	6	-	-	μs
$\overline{E2}$ Setup to $\overline{E1}$ and/or $\overline{E3}$ Falling Edge	t_4	1.5	-	-	μs
$\overline{E1}$ Falling Edge to $\overline{E3}$ Falling Edge	t_5	248	-	-	μs

Notes: 19. Pulse output timing is specified at DCLK = 4.096 MHz, E2MODE = 0, and E3MODE[1:0] = 0. Refer to [6.7 Energy Pulse Outputs](#) on page 19 for more information on pulse output pins.

20. Timing is proportional to the frequency of DCLK.

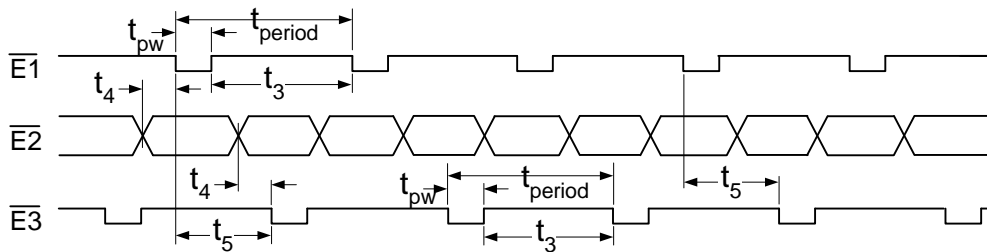

Figure 2. Timing Diagram for $\overline{E1}$, $\overline{E2}$, and $\overline{E3}$

ABSOLUTE MAXIMUM RATINGS

WARNING: Operation at or beyond these limits may result in permanent damage to the device.

Normal operation is not guaranteed at these extremes.

Parameter	Symbol	Min	Typ	Max	Unit
DC Power Supplies (Notes 21 and 22)					
Positive Digital	VD+	-0.3	-	+6.0	V
Positive Analog	VA+	-0.3	-	+6.0	V
Input Current, Any Pin Except Supplies (Notes 23, 24, 25)	I_{IN}	-	-	± 10	mA
Output Current, Any Pin Except VREFOUT	I_{OUT}	-	-	100	mA
Power Dissipation (Note 26)	P_{D}	-	-	500	mW
Analog Input Voltage (All Analog Pins)	V_{INA}	- 0.3	-	(VA+) + 0.3	V
Digital Input Voltage (All Digital Pins)	V_{IND}	-0.3	-	(VD+) + 0.3	V
Ambient Operating Temperature	T_{A}	-40	-	85	$^{\circ}\text{C}$
Storage Temperature	T_{stg}	-65	-	150	$^{\circ}\text{C}$

Notes: 21. VA+ and AGND must satisfy $[(\text{VA}+) - (\text{AGND})] \leq + 6.0 \text{ V}$.

22. VD+ and AGND must satisfy $[(\text{VD}+) - (\text{AGND})] \leq + 6.0 \text{ V}$.

23. Applies to all pins including continuous over-voltage conditions at the analog input pins.

24. Transient current of up to 100 mA will not cause SCR latch-up.

25. Maximum DC input current for a power supply pin is $\pm 50 \text{ mA}$.

26. Total power dissipation, including all input currents and output currents.

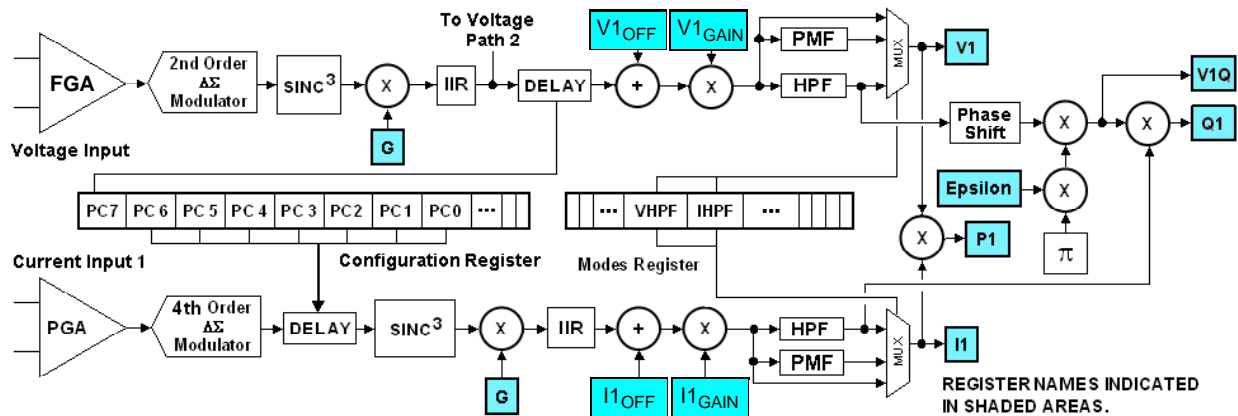

Figure 3. Signal Flow for V1, I1, P1, Q1 Measurements

4. SIGNAL PATH DESCRIPTION

The data flow for voltage and current measurement and the other calculations are shown in Figures 3, 4, and 5.

The data flow consists of two current paths and two voltage paths. Both voltage paths are derived from the same differential input pins. Each current path has its own differential input pins.

4.1 Analog-to-Digital Converters

The voltage and temperature channels use second-order delta-sigma modulators and the two current channels use fourth-order delta-sigma modulators to convert the analog inputs to single-bit digital data streams. The converters sample at a rate of $DCLK/8$. This high sampling provides a wide dynamic range and simplifies anti-alias filter design.

4.2 Decimation Filters

The single-bit modulator output data is widened to 24 bits and down-sampled to $DCLK/1024$ with low-pass

decimation filters. These decimation filters are third-order Sinc. Their outputs are passed through third-order IIR “anti-sinc” filters, used to compensate for the amplitude roll-off of the decimation filters.

4.3 Phase Compensation

Phase compensation changes the phase of current relative to voltage by changing the sampling time in the decimation filters. The amount of phase shift is set by bits PC[7:0] in the Configuration register (*Config*) for channel 1 and bits PC[7:0] in the Control register (*Ctrl*) for channel 2.

Phase compensation, PC[7:0] is a signed two’s complement binary value in the range of -1.0 to almost +1.0 output word rate (OWR) samples. For a sample rate of 4000 Hz, the delay range is $\pm 250 \mu\text{s}$, a phase shift of $\pm 4.5^\circ$ at 50 Hz and $\pm 5.4^\circ$ at 60 Hz. The step size would be 0.0352° at 50 Hz and 0.0422° at 60 Hz at this sample rate.

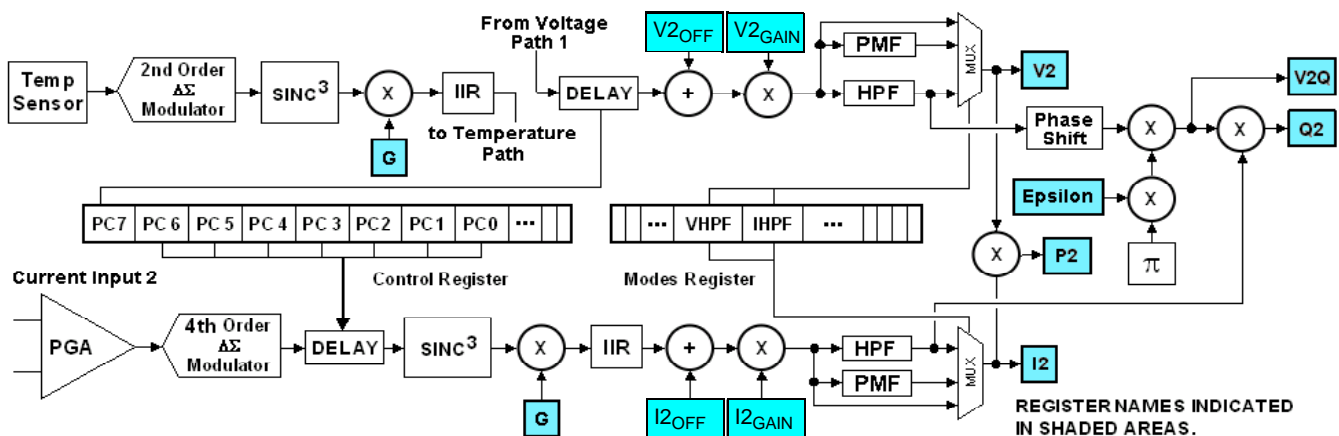

Figure 4. Signal Flow for V2, I2, P2, Q2 Measurements

4.4 DC Offset and Gain Correction

The system and chip inherently have gain and offset errors which can be removed using the gain and offset registers. (See [Section 9. System Calibration](#) on page 39). Each measurement channel has its own registers. For every channel, the output of the IIR filter is added to the offset register and multiplied by the gain register.

4.5 High-pass Filters

Optional high-pass filters (HPF in [Figures 3 and 4](#)) remove any DC from the selected signal paths. Subsequently, DC will also be removed from power, and all low-rate results. (see [Figures 5](#)).

Each energy channel has a current and voltage path. If an HPF is enabled in only one path, a phase-matching filter (PMF) is applied to the other path which matches the amplitude and phase delay of the HPF in the band

of interest, but passes DC. For more information, see [6.5 High-pass Filters](#) on page 19. The HPF filter multiplexers drive the *I1*, *V1*, *I2*, and *V2* result registers.

4.6 Low-Rate Calculations

Low-rate results are derived from sample-rate results integrated over *N* samples, where *N* is the value stored in the Cycle Count register. The low-rate interval is the sample interval multiplied by *N*.

4.7 RMS Results

The root mean square (*RMS* in [Figure 5](#)) calculations are performed on *N* instantaneous voltage and current samples, using the formula:

$$I_{\text{RMS}} = \sqrt{\frac{\sum_{n=0}^{N-1} I_n^2}{N}}$$

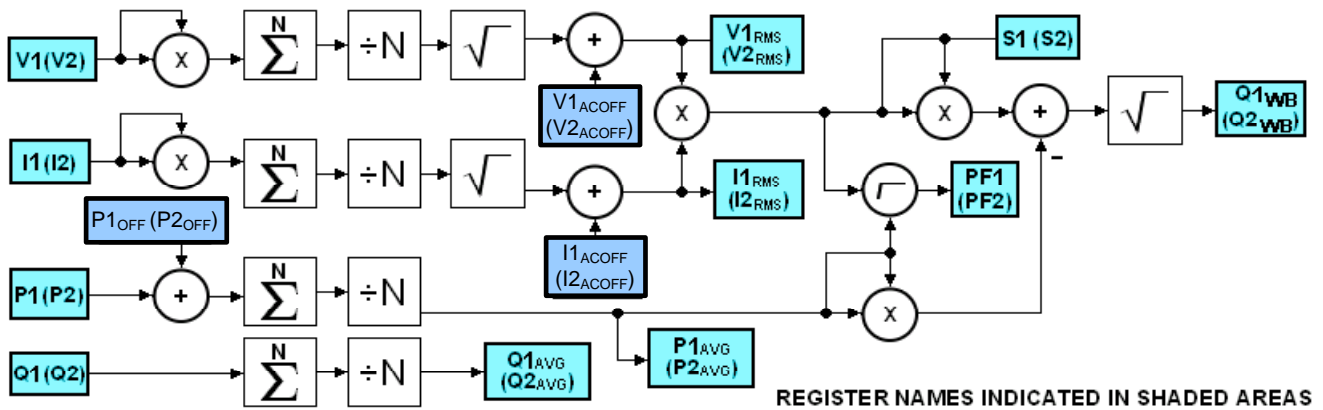

Figure 5. Low-rate Calculations

4.8 Power and Energy Results

The instantaneous voltage and current samples are multiplied to obtain the instantaneous power ($P1$, $P2$) (see Figure 3 and 4). The product is then averaged over N conversions to compute active power ($P1_{AVG}$, $P2_{AVG}$).

Apparent power ($S1$, $S2$) is the product of RMS voltage and current as shown:

$$S = V_{RMS} \times I_{RMS}$$

Power factor ($PF1$, $PF2$) is active power divided by apparent power as shown below. The sign of the power factor is determined by the active power.

$$PF = \frac{P_{ACTIVE}}{S}$$

Wideband reactive power ($Q1_{WB}$, $Q2_{WB}$) is calculated by doing a vector subtraction of active power from apparent power.

$$Q_{WB} = \sqrt{S^2 - P_{ACTIVE}^2}$$

Quadrature power ($Q1$, $Q2$) are sample rate results obtained by multiplying instantaneous current ($I1$, $I2$) by instantaneous quadrature voltage ($V1Q$, $V2Q$) which are created by phase shifting instantaneous voltage ($V1$, $V2$) 90 degrees using first-order integrators. (see Figure 3 and 4). The gain of these integrators is inversely relat-

ed to line frequency, so their gain is corrected by the *Epsilon* register, which is based on line frequency.

Reactive power ($Q1_{AVG}$, $Q2_{AVG}$) is generated by integrating the instantaneous quadrature power over N samples.

4.9 Peak Voltage and Current

Peak current ($I1_{PEAK}$, $I2_{PEAK}$) and peak voltage ($V1_{PEAK}$, $V2_{PEAK}$) are the largest current and voltage samples detected in the previous low-rate interval.

4.10 Power Offset

The power offset registers, $P1_{OFF}$ ($P2_{OFF}$) can be used to offset erroneous power sources resident in the system not originating from the power line. Residual power offsets are usually caused by crosstalk into current paths from voltage paths or from ripple on the meter or chip's power supply, or from inductance from a nearby transformer.

These offsets can be either positive or negative, indicating crosstalk coupling either in phase or out of phase with the applied voltage input. The power offset registers can compensate for either condition.

To use this feature, measure the average power at no load using either Single or Continuous Conversion commands. Take the measured result (from the $P1_{AVG}$ ($P2_{AVG}$) register), invert (negate) the value and write it to the associated power offset register, $P1_{OFF}$ ($P2_{OFF}$).

5. PIN DESCRIPTIONS

5.1 Analog Pins

The CS5464 has three differential inputs: VIN_{\pm} , $IIN1_{\pm}$, and $IIN2_{\pm}$ are the voltage, current1, and current2 inputs, respectively. A single-ended power fail monitor input, voltage reference input, and voltage reference output are also available.

5.1.1 Voltage Inputs

The output of the line voltage resistive divider or transformer is connected to the $VIN+$ and $VIN-$ input pins of the CS5464. The voltage channel is equipped with a 10x, fixed-gain amplifier. The full-scale signal level that can be applied to the voltage channel is $\pm 250\text{mV}$. If the input signal is a sine wave, the maximum RMS voltage is $250\text{mVp} / \sqrt{2} \approx 176.78\text{mVRMS}$ which is approximately 70.7% of maximum peak voltage.

5.1.2 Current1 and Current2 Inputs

The output of the current-sensing resistor or transformer is connected to the $IIN1+$ ($IIN2+$) and $IIN1-$ ($IIN2-$) input pins of the CS5464. To accommodate different current-sensing elements, the current channel incorporates a programmable gain amplifier (PGA) with two selectable input gains. The full-scale signal level for the current channels is $\pm 50\text{mV}$ or $\pm 250\text{mV}$. If the input signal is a sine wave, the maximum RMS voltage is 35.35mVRMS or 176.78mVRMS which is approximately 70.7% of maximum peak voltage.

5.1.3 Power Fail Monitor Input

An analog input (PFMON) is provided to determine when a power loss is imminent. By connecting a resistive divider from the unregulated meter power supply to the PFMON input, an interrupt can be generated, or the Low Supply Detected (LSD) *Status* register bit can be monitored to indicate low-supply conditions. The PFMON input has a comparator that trips around the level of the voltage reference input ($VREFIN$).

5.1.4 Voltage Reference Input

The CS5464 requires a stable voltage reference of 2.5 V applied to the $VREFIN$ pin. This reference can be supplied from an external voltage reference or from the $VREFOUT$ output. A bypass capacitor of at least $0.1\ \mu\text{F}$ is recommended at the $VREFIN$ pin.

5.1.5 Voltage Reference Output

The CS5464 generates a 2.5 V reference ($VREFOUT$). It is suitable for driving the $VREFIN$ pin, but has very little fan-out and is not recommended for driving external circuits.

5.1.6 Crystal Oscillator

An external quartz crystal can be connected to the XIN and $XOUT$ pins as shown in Figure 6. To reduce system cost, each pin is supplied with an on-chip, phase-shifting capacitor to ground.

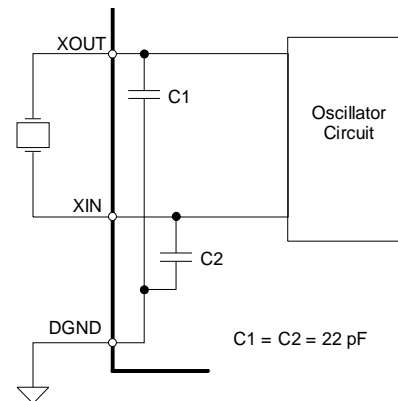

Figure 6. Oscillator Connections

Alternatively, an external clock source can be connected to the XIN pin.

5.2 Digital Pins

5.2.1 Reset Input

The active-low $\overline{\text{RESET}}$ pin, when asserted, will halt all CS5464 operations and reset internal hardware registers and states. When de-asserted, an initialization sequence begins, setting default register values.

5.2.2 CPU Clock Output

A logic-level clock output (CPUCLK) is provided at the crystal frequency to drive an external CPU or microcontroller clock. Two phase choices are available.

5.2.3 Interrupt Output

The $\overline{\text{INT}}$ pin indicates an enabled Internal Status register (*Status*) bit is set. *Status* register bits indicate conditions such as data ready, modulator oscillations, low supply, voltage sag, current faults, numerical overflows, and result updates.

5.2.4 Energy Pulse Outputs

The CS5464 provides three pins ($\overline{\text{E1}}$, $\overline{\text{E2}}$, $\overline{\text{E3}}$) for pulse energy outputs. These pins can also be used to output other conditions, such as voltage sign, power fail monitor, or energy channel in use.

5.2.5 Serial Interface

The CS5464 provides 5 pins, SCLK, SDI, SDO, $\overline{\text{CS}}$, and MODE for communication between a host microcontroller or serial E²PROM and the CS5464.

MODE is an input that, when high, indicates to the CS5464 that a serial E²PROM is being used instead of a host microcontroller. It has a weak pull-down allowing it to be left unconnected if microcontroller mode is used.

SCLK is used to shift and qualify serial data. Serial data changes as a result of the falling edge of SCLK and is valid during the rising edge. It is a Schmitt-trigger input

for host microcontrollers, and a driven output for serial E²PROMs.

SDI is the serial data input to the CS5464.

SDO is the serial data output from the CS5464. Its output drivers are disabled whenever $\overline{\text{CS}}$ is de-asserted, allowing other devices to drive the SDO line.

$\overline{\text{CS}}$ is the chip select input for the serial bus. A high logic level de-asserts it, tri-stating the SDO pin and clearing the serial interface. A low logic level enables the serial port. This pin may be tied low for systems not requiring multiple SDO drivers. $\overline{\text{CS}}$ is a driven output when interfacing to serial E²PROMs.

6. SETTING UP THE CS5464

6.1 Clock Divider

The internal clock to the CS5464 needs to operate around 4 MHz. However, by using the internal clock divider, a higher crystal frequency can be used. This is important when driving an external microcontroller requiring a faster clock and using the CPUCLK output.

K is the divide ratio from the crystal input to the internal clock and is selected with Configuration register (*Config*) bits K[3:0]. It has a range of 1 to 16. A value of zero results in a setting of 16.

6.2 CPU Clock Inversion

By default, CPUCLK is inverted from XIN. Setting Configuration register bit iCPU removes this inversion. This can be useful when one phase adds more noise to the system than the other.

6.3 Interrupt Pin Behavior

The behavior of the $\overline{\text{INT}}$ pin is controlled by the IMODE and IINV bits in the Configuration register as shown.





IMODE	IINV	$\overline{\text{INT}}$ Pin
0	0	Active-low Level 
0	1	Active-high Level 
1	0	Low Pulse 
1	1	High Pulse 

Table 1. Interrupt Configuration

If IMODE = 1, the duration of the $\overline{\text{INT}}$ pulse will be two DCLK cycles, where DCLK = MCLK/K.

6.4 Current Input Gain Ranges

Control register bits I1gain (I2gain) select the input range of the current inputs.

I1gain, I2gain	Maximum Input	Gain
0	±250 mV	10x
1	±50 mV	50x

Table 2. Current Input Gain Ranges

6.5 High-pass Filters

Mode Control (*Modes*) register bits VHPF and IHPF activate the HPF in the voltage and current paths, respectively. Each energy channel has separate VHPF and IHPF bits. When a high-pass filter is enabled in only one

path within a channel, a phase matching filter (PMF) is applied to the other path within that channel. The PMF filter matches the amplitude and phase response of the HPF in the band of interest, but passes DC.

VHPF	IHPF	Filter Configuration
0	0	No filter on Voltage or Current
0	1	HPF on Current, PMF on Voltage
1	0	HPF on Voltage, PMF on Current
1	1	HPF on Current and Voltage

Table 3. High-pass Filter Configuration

6.6 Cycle Count

Low-rate calculations, such as average power and RMS voltage and current integrate over several (*N*) output word rate (OWR) samples. The duration of this averaging window is set by the Cycle Count (*N*) register. By default, Cycle Count is set to 4000 (1 second at output word rate [OWR] of 4000 Hz). The minimum value for Cycle Count is 10.

6.7 Energy Pulse Outputs

By default, $\overline{\text{E1}}$ outputs active energy, $\overline{\text{E3}}$, reactive energy, and $\overline{\text{E2}}$, the sign of both active and reactive energy. (See [Figure 2. Timing Diagram for E1, E2, and E3](#) on page 13.)

Three pairs of bits in the Mode Control (*Modes*) register control the operation of these outputs. These bits are named E1MODE[1:0], E2MODE[1:0], and E3MODE[1:0]. Some combinations of these bits override others, so read the following paragraphs carefully.

The $\overline{\text{E2}}$ pin can output energy sign, apparent energy, or energy channel in use (1 or 2). Table 4 lists the functions of $\overline{\text{E2}}$ as controlled by E2MODE[1:0] in the *Modes* register.

Note: E2MODE[1:0]=3 is a special mode.

E2MODE1	E2MODE0	$\overline{\text{E2}}$ output
0	0	Energy Sign
0	1	Apparent Energy
1	0	Channel in Use
1	1	Enable E1MODE

Table 4. $\overline{\text{E2}}$ Pin Configuration

The $\overline{\text{E3}}$ pin can output reactive energy, power fail monitor status, voltage sign, or apparent energy. Table 5

lists the functions of $\overline{E3}$ as controlled by E3MODE[1:0] in the *Modes* register when E1MODE is not enabled.

E3MODE1	E3MODE0	$\overline{E3}$ output
0	0	Reactive Energy
0	1	Power Fail Monitor
1	0	Voltage Sign
1	1	Apparent Energy

Table 5. $\overline{E3}$ Pin Configuration

When both E2MODE bits are high, the E1MODE bits are enabled, allowing active, apparent, reactive, or wideband reactive energy for **both** energy channels to be output on $\overline{E1}$ and $\overline{E2}$. Table 6 lists the functions of $\overline{E1}$ and $\overline{E2}$ with E1MODE enabled.

E1MODE1	E1MODE0	$\overline{E1}$ / $\overline{E2}$ outputs
0	0	Active Energy
0	1	Apparent Energy
1	0	Reactive Energy
1	1	Wideband Reactive

Table 6. $\overline{E1}$ / $\overline{E2}$ Modes

When E1MODE bits are enabled, the $\overline{E3}$ pin outputs either the power fail monitor status, or the sign of the $\overline{E1}$ and $\overline{E2}$ outputs. Table 7 list the functions of the $\overline{E3}$ pin using E3MODE[1:0] in the *Modes* register when E1MODE is enabled.

E3MODE1	E3MODE0	$\overline{E3}$ output
0	0	Power Fail Monitor
0	1	Energy Sign
1	0	not used
1	1	not used

Table 7. $\overline{E3}$ Pin with E1MODE enabled

6.8 No Load Threshold

The No Load Threshold register ($Load_{MIN}$) is used to zero out the contents of E_{PULSE} and Q_{PULSE} registers if their magnitude is less than the $Load_{MIN}$ register value.

6.9 Energy Pulse Width

Note: Energy Pulse Width (*PulseWidth*) only applies to $\overline{E1}$, $\overline{E2}$, or $\overline{E3}$ pins that are configured to output pulses. When any are configured to output steady-state signals, such as voltage sign, energy channel in use, power fail monitor, or energy sign, pulse widths and output rates do not apply.

The pulse width time (t_{pw}) in Figure 2, is set by the value in the *PulseWidth* register which is an integer multiple of the sample or output word rate (OWR). At OWR of 4000 Hz (a period of 250 uS) $t_{pw} = PulseWidth \times 250uS$. By default, *PulseWidth* is set to 1.

6.10 Energy Pulse Rate

The full-scale pulse frequency of enabled $\overline{E1}$, $\overline{E2}$, $\overline{E3}$ pins is the *PulseRate* x output word rate (OWR)/2. The actual pulse frequency is the full-scale pulse frequency multiplied by the pulse register's (E_{PULSE} , S_{PULSE} , Q_{PULSE}) value.

Example:

If the output word rate (OWR) is 4000 Hz, and the *PulseRate* is set to 0.05, the full-rate pulse frequency is $0.05 \times 4000 / 2 = 100$ Hz. If the E_{PULSE} register, driving $\overline{E1}$, is 0.4567, the pulse output rate on $\overline{E1}$ will be $100 \text{ Hz} \times 0.4567 = 45.67$ Hz.

6.11 Voltage Sag/Current Fault Detection

Voltage sag detection is used to determine when averaged voltage falls below a predetermined level for a specified interval of time. Current fault detection determines when averaged current falls below a predetermined level for a specified interval of time.

The specified interval of time (duration) is set by the value in the $V1Sag_{DUR}$ ($V2Sag_{DUR}$) and $I1Fault_{DUR}$ ($I2Fault_{DUR}$) registers. Setting any of these to zero (default) disables the detect feature for the given channel. The value is in output word rate (OWR) samples. The predetermined level is set by the values in the $V1Sag_{LEVEL}$ ($V2Sag_{LEVEL}$) and $I1Fault_{LEVEL}$ ($I2Fault_{LEVEL}$) registers.

Since the values of $V1$ and $V2$ come from the same input, only one voltage sag detector is necessary.

For each enabled input channel, the measured value is rectified and compared to the associated level register. Over the duration window, the number of samples above and below the level are counted. If the number of samples below the level exceeds the number of samples above, a *Status* register bit $V1_{SAG}$ ($V2_{SAG}$), $I1_{FAULT}$ ($I2_{FAULT}$) is set, indicating a sag or fault condition. (see [Figure 7](#)).

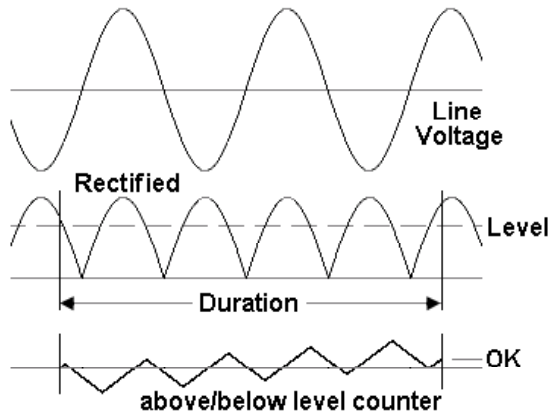

Figure 7. Sag and Fault Detect

6.12 Epsilon

The *Epsilon* register is used to set the gain of the 90° phase shift used in the quadrature power calculation.

The value in the *Epsilon* register is the ratio of the line frequency to the output word rate (OWR). It is, by default, 50/4000 (0.0125), for 50 Hz line and 4000 Hz sample (OWR) frequencies.

For 60 Hz line frequency, it is 60/4000 (0.015). Other output word rates (OWR) can be used.

Epsilon can also be calculated automatically by the CS5464 by setting the AFC bit in the Mode Control (*Modes*) register. The Frequency Update bit (FUP) in the *Status* register is set every time the *Epsilon* register has been automatically updated.

6.13 Temperature Measurement

The on-chip temperature sensor is designed to measure temperature and optionally compensate for temperature drift of the voltage reference. It uses the V_{BE} of a transistor to determine temperature.

Temperature measurements are stored in the Temperature register (T) which, by default, is configured to a range of ± 128 degrees on the Celsius ($^{\circ}\text{C}$) scale.

The application program can change both the scale and range of Temperature (T) by changing the Temperature Gain (T_{GAIN}) and Temperature Offset (T_{OFF}) registers.

Two values must be known — the transistor's ΔV_{BE} per degree, and the transistor's V_{BE} at 0 degrees. At the time of this publication, these values are:

$$\Delta V_{BE} \text{ (per degree)} = 0.2769523 \text{ mV}/^{\circ}\text{C or } ^{\circ}\text{K}$$

$$V_{BE0} = 79.2604368 \text{ mV at } 0^{\circ}\text{C}$$

To determine the values to write to T_{GAIN} and T_{OFF} , use the following formulae:

$$T_{GAIN} = AD_{FS} / \Delta V_{BE} / T_{FS} \times 2^{17}$$

$$T_{OFF} = -V_{BE0} / \Delta V_{BE} \times 2^{23}$$

In the above equations, AD_{FS} is the full-scale input range of the temperature A/D converter or 833.333 mV and T_{FS} is the desired full-scale range of the Temperature register. The binary exponents are the bit positions of the binary point of these registers.

To use the Celsius scale ($^{\circ}\text{C}$) and cover the chip's operating temperature range of -40°C to $+85^{\circ}\text{C}$, the Temperature register range needs to be ± 128 degrees. T_{FS} should be 128 degrees.

$$\begin{aligned} T_{GAIN} &= 833.333 / 0.2769523 / 128 \times 131072 \\ &= 3081155 \text{ (0x2F03C3)} \end{aligned}$$

$$\begin{aligned} T_{OFF} &= -79.2604368 / 0.2769523 \times 131072 \\ &= -3081155 \text{ (0xF3D35A)} \end{aligned}$$

These are the actual default values for these registers.

T_{GAIN} and T_{OFF} can also be used to calibrate the gain and/or offset of the temperature sensor or A/D converter. (See [Section 9. System Calibration](#) on page 39).

To use the Kelvin ($^{\circ}\text{K}$) scale, simply add 273 times $\Delta V_{BE} / AD_{FS} \times 2^{23}$ to T_{OFF} since $0^{\circ}\text{C} = 273^{\circ}\text{K}$. You will also need more range. Since -40°C to $+85^{\circ}\text{C}$ is 233°K to 358°K , a T_{FS} of 512 degrees should be used in the T_{GAIN} calculation.

To use the Fahrenheit ($^{\circ}\text{F}$) scale, multiply ΔV_{BE} by 5/9 and add 32 times the new $\Delta V_{BE} / AD_{FS} \times 2^{23}$ to T_{OFF} since $0^{\circ}\text{C} = 32^{\circ}\text{F}$. You will also want to use a T_{FS} of 256 degrees to cover the -40°C to $+85^{\circ}\text{C}$ range.

The Temperature register (T) updates every 2240 output word rate (OWR) samples. The *Status* register bit TUP indicates when T is updated.

7. USING THE CS5464

7.1 Initialization

The CS5464 uses a power-on-reset circuit (POR) to provide an internal reset until the analog voltage reaches 4.0 V. The $\overline{\text{RESET}}$ input pin can also be used by the application circuit to reset the part.

After $\overline{\text{RESET}}$ is removed and the oscillator is stable, an initialization program is executed to set the default register values.

A Software Reset command is also provided to allow the application to run the initialization program without removing power or asserting $\overline{\text{RESET}}$.

The application should avoid sending commands during initialization. The DRDY bit in the *Status* register indicates when the initialization program has completed.

7.2 Power-down States

The CS5464 has two power-down states, stand-by and sleep. In the stand-by state, all circuitry except the voltage reference and crystal oscillator is powered off. In sleep state, all circuitry except the instruction decoder is powered off.

To return the device to the active state, send a Wake-Up/Halt command to the device. When returning from stand-by mode, registers will retain their contents prior to entering the stand-by state. When returning from sleep mode, a complete initialization occurs.

7.3 Tamper Detection and Correction

The CS5464 provides compensation for at least two forms of meter tampering. A second current input is provided in the event that the primary input is impaired by tampering. (See Figure 14 on page 42). An internal RMS voltage reference is also available in the event that the voltage input has been compromised by tampering.

Power and energy are calculated for BOTH current inputs (both energy channels). The CS5464 can automatically choose the channel with the greater magnitude. The register E_{MIN} , (also called $I_{rms_{MIN}}$) sets a minimum level for automatic channel selection, and $I_{chan_{LEVEL}}$ sets a minimum difference that will allow a channel

change. *Modes* register bit *Ichan* selects the energy channel, and is normally driven by the CS5464 program. This affects the pulse registers and pulse energy outputs. (See figure 8).

The application program can also choose the more appropriate energy channel. *Modes* register bit *Ihold* disables automatic selection and *Ichan* can be driven by the application. Shown below is the channel selector.

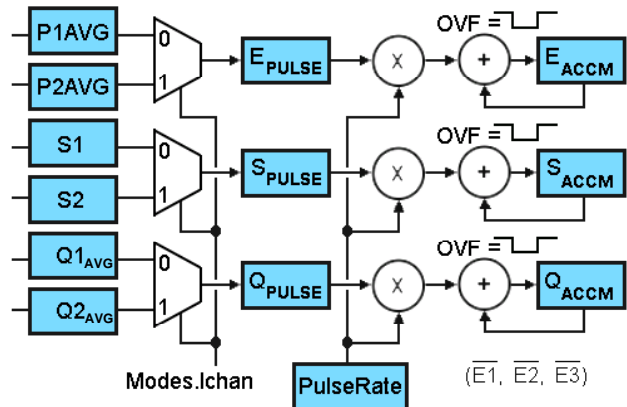

Figure 8. Energy Channel Selection

If the application detects that the voltage input has been impaired it may choose to use the fixed internal RMS voltage reference by setting the VFIX bit in the *Modes* register. The value of this reference ($V_{F_{RMS}}$) is by default 0.707107 (full-scale RMS) but can be changed by the application program. (See figure 9)

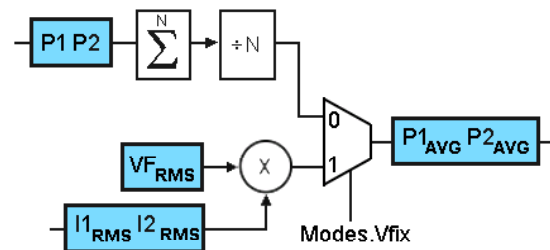

Figure 9. Fixed RMS Voltage Selection

7.4 Command Interface

Commands and data are transferred most-significant bit (MSB) first. [Figure 1](#) on page 12, defines the serial port timing. Commands are clocked in on SDI using SCLK. They are a single byte (8 bits) long and fall into one of four basic types:

1. Register Read
2. Register Write
3. Synchronizing
4. Instructions

Register reads will cause up to four bytes of register data to be clocked out, MSB first on the SDO pin by SCLK. During this time, other commands can be clocked in on the SDI pin. Other commands will not interrupt read data, except another register read, which will cause the new read data to appear on SDO.

Synchronizing can be sent while read data is being clocked out if no other commands need to be sent.

Synchronizing commands are also used to synchronize the serial port to a byte boundary. The $\overline{\text{CS}}$ and $\overline{\text{RESET}}$ pins will also synchronize the serial port.

Register writes require three bytes of write data to follow, clocked in on the SDI pin, MSB first by SCLK.

Instructions are commands that will interrupt any instruction currently executing and begin the new instruction. These include conversions, calibrations, power control, and soft reset.

(See [Section 7.6 Commands](#) on page 24).

7.5 Register Paging

Read and Write commands access one of 32 registers within a specified page. The Register Page Select register's (*Page*) default value is 0. To access registers in another page, write the desired page number to the *Page* register. The *Page* register is always at address 31 and is accessible from within any page.

7.6 Commands

All commands are 1 byte (8 bits) long. Many command values are unused and should NOT be written by the application program. All commands except register reads, register writes, or synchronizing commands will abort any conversion, calibration, or any initialization sequence currently executing. This includes reset. No commands other than reads or synchronizing should be executed until the reset sequence completes.

7.6.1 Conversion

B7	B6	B5	B4	B3	B2	B1	B0
1	1	1	0	CC	0	0	0

Executes a conversion (measurement) program.

CC Continuous/Single Conversion
 0 = Perform a Single Conversion (0xE0)
 1 = Perform Continuous Conversion (0xE8)

7.6.2 Synchronization (SYNC0 and SYNC1)

B7	B6	B5	B4	B3	B2	B1	B0
1	1	1	1	1	1	1	SYNC

The serial interface is bidirectional. While reading data on the SDO output, the SDI input must be receiving commands. If no command is needed during a read, SYNC0 or SYNC1 commands can be sent while read data is received on SDO.

The serial port is normally initialized by de-asserting \overline{CS} . An alternative method of initialization is to send 3 or more SYNC1 commands followed by a SYNC0. This is useful in systems where \overline{CS} is not used and tied low.

7.6.3 Power Control (Stand-by, Sleep, Wake-up/Halt and Software Reset)

B7	B6	B5	B4	B3	B2	B1	B0
1	0	S1	S0	0	0	0	0

The CS5464 has two power-down states, stand-by and sleep. In stand-by, all circuitry except the voltage reference and clocks are turned off. In sleep, all circuitry except the command decoder is turned off. A Wake-up/Halt command restores full-power operation after stand-by and issues a hardware reset after sleep. The Software Reset command is a program that emulates a pin reset and is not a power control function.

S[1:0] 00 = Software Reset
 01 = Sleep
 10 = Wake-up/Halt
 11 = Stand-by

7.6.4 Calibration

B7	B6	B5	B4	B3	B2	B1	B0
1	0	CAL5	CAL4	CAL3	CAL2	CAL1	CAL0

The CS5464 can perform gain and offset calibrations using either DC or AC signals. Proper input levels must be applied to the current inputs and voltage input before performing calibrations.

CAL[5:4]* 00 = DC Offset
 01 = DC Gain
 10 = AC Offset
 11 = AC Gain

CAL[3:0] 0001 = Current for Channel 1
 0010 = Voltage for Channel 1
 0100 = Current for Channel 2
 1000 = Voltage for Channel 2

Note: Anywhere from 1 to all 4 channels can be calibrated simultaneously. Voltage channels 1 and 2 use the same voltage input. Commands with CAL[5:0] = 0 are not calibrations.

7.6.5 Register Read and Write

B7	B6	B5	B4	B3	B2	B1	B0
0	W/R	RA4	RA3	RA2	RA1	RA0	0

Read and Write commands provide access to on-chip registers. After a Read command, the addressed data can be clocked out the SDO pin by SCLK. After a Write command, 24 bits of write data must follow. The data is transferred to the addressed register after the 24th data bit is received. Registers are organized into pages of 32 addresses each. To access a desired page, write its number to the *Page* register at address 31.

$\overline{W/R}$ Write/Read control
 0 = Read
 1 = Write

RA[4:0] Register address.

Page 0 Registers

Address	RA[4:0]	Name	Description
0	00000	Config	Configuration
1	00001	I1	Instantaneous Current Channel 1
2	00010	V1	Instantaneous Voltage Channel 1
3	00011	P1	Instantaneous Power Channel 1
4	00100	P1 _{AVG}	Active Power Channel 1
5	00101	I1 _{RMS}	RMS Current Channel 1
6	00110	V1 _{RMS}	RMS Voltage Channel 1
7	00111	I2	Instantaneous Current Channel 2
8	01000	V2	Instantaneous Voltage Channel 2
9	01001	P2	Instantaneous Power Channel 2
10	01010	P2 _{AVG}	Active Power Channel 2
11	01011	I2 _{RMS}	RMS Current Channel 2
12	01100	V2 _{RMS}	RMS Voltage Channel 2
13	01101	Q1 _{AVG}	Reactive Power Channel 1
14	01110	Q1	Instantaneous Quadrature Power Channel 1
15	01111	Status	Internal Status
16	10000	Q2 _{AVG}	Reactive Power Channel 2
17	10001	Q2	Instantaneous Quadrature Power Channel 2
18	10010	I1 _{PEAK}	Peak Current Channel 1
19	10011	V1 _{PEAK}	Peak Voltage Channel 1
20	10100	S1	Apparent Power Channel 1
21	10101	PF1	Power Factor Channel 1
22	10110	I2 _{PEAK}	Peak Current Channel 2
23	10111	V2 _{PEAK}	Peak Voltage Channel 2
24	11000	S2	Apparent Power Channel 2
25	11001	PF2	Power Factor Channel 2
26	11010	Mask	Interrupt Mask
27	11011	T	Temperature
28	11100	Ctrl	Control
29	11101	EPULSE	Active Energy Pulse Output
30	11110	SPULSE	Apparent Energy Pulse Output
31 R	11111	QPULSE	Reactive Energy Pulse Output
31 W	11111	Page	Register Page Select

Warning: Do not write to unpublished register locations.

Page1 Registers

<u>Address</u>	<u>RA[4:0]</u>	<u>Name</u>	<u>Description</u>
0	00000	I1 _{OFF}	Current DC Offset Channel 1
1	00001	I1 _{GAIN}	Current Gain Channel 1
2	00010	V1 _{OFF}	Voltage DC Offset Channel 1
3	00011	V1 _{GAIN}	Voltage Gain Channel 1
4	00100	P1 _{OFF}	Power Offset Channel 1
5	00101	I1 _{ACOFF}	Current AC (RMS) Offset Channel 1
6	00110	V1 _{ACOFF}	Voltage AC (RMS) Offset Channel 1
7	00111	I2 _{OFF}	Current DC Offset Channel 2
8	01000	I2 _{GAIN}	Current Gain Channel 2
9	01001	V2 _{OFF}	Voltage DC Offset Channel 2
10	01010	V2 _{GAIN}	Voltage Gain Channel 2
11	01011	P2 _{OFF}	Power Offset Channel 2
12	01100	I2 _{ACOFF}	Current AC (RMS) Offset Channel 2
13	01101	V2 _{ACOFF}	Voltage AC (RMS) Offset Channel 2
14	01110	PulseWidth	Pulse Output Width
15	01111	PulseRate	Pulse Output Rate (frequency)
16	10000	Modes	Mode Control
17	10001	Epsilon	Ratio of Line to Sample Frequency
18	10010	Ichan _{LEVEL}	Irms or E Channel Select Trip Level
19	10011	N	Cycle Count (Number of OWR Samples in One Low-rate Interval)
20	10100	Q1 _{WB}	Wideband Reactive Power from Power Triangle Channel 1
21	10101	Q2 _{WB}	Wideband Reactive Power from Power Triangle Channel 2
22	10110	T _{GAIN}	Temperature Sensor Gain
23	10111	T _{OFF}	Temperature Sensor Offset
24	11000	E _{MIN} (I _{rmsMIN})	Energy Channel Selector Minimum Operating Level
25	11001	T _{SETTLE}	Filter Settling Time for Conversion Startup
26	11010	Load _{MIN}	No Load Threshold
27	11011	V _{F_{RMS}}	Voltage RMS Fixed Reference
28	11100	G	System Gain
29	11101	Time	System Time (in samples)
31 W	11111	Page	Register Page Select

Page2 Registers

<u>Address</u>	<u>RA[4:0]</u>	<u>Name</u>	<u>Description</u>
0	00000	V1Sag _{DUR}	V Sag Duration Channel 1
1	00001	V1Sag _{LEVEL}	V Sag Level Channel 1
4	00100	I1Fault _{DUR}	I Fault Duration Channel 1
5	00101	I1Fault _{LEVEL}	I Fault Level Channel 1
8	01000	V2Sag _{DUR}	V Sag Duration Channel 2
9	01001	V2Sag _{LEVEL}	V Sag Level Channel 2
12	01100	I2Fault _{DUR}	I Fault Duration Channel 2
13	01101	I2Fault _{LEVEL}	I Fault Level Channel 2
31 W	11111	Page	Register Page Select

Warning: Do not write to unpublished register locations.

8. REGISTER DESCRIPTIONS

1. “Default” = bit states after power-on or reset
2. DO NOT write a “1” to any unpublished register bit.
3. DO NOT write to any unpublished register address.

8.1 Page Register

8.1.1 *Page* – Address: 31, Write-only, can be written from ANY page.

MSB					LSB	
2 ⁶	2 ⁵	2 ⁴	2 ³	2 ²	2 ¹	2 ⁰

Default = 0

Register Read and Write commands contain only 5 address bits. But the internal address bus of the CS5464 is 12 bits wide. Therefore, registers are organized into “Pages”. There are 128 pages of 32 registers each. The *Page* register provides the 7 high-order address bits and selects one of the 128 register pages. Not all pages are used,

Page is a write-only integer containing 7 bits.

8.2 Page 0 Registers

8.2.1 *Configuration (Config)* – Address: 0

23	22	21	20	19	18	17	16
PC7	PC6	PC5	PC4	PC3	PC2	PC1	PC0
15	14	13	12	11	10	9	8
EWA	-	-	IMODE	IINV	-	-	-
7	6	5	4	3	2	1	0
-	-	-	iCPU	K3	K2	K1	K0

Default = 1 (K=1)

PC[7:0] Phase compensation for channel 1. Sets a delay in voltage, relative to current. Phase is signed and in the range of $-1.0 \leq \text{value} < 1.0$ sample (OWR) intervals.

EWA Allows the $\overline{E1}$ and $\overline{E2}$ pins to be configured as open-drain outputs.
 0 = Normal Outputs
 1 = Open-drain Outputs

IMODE, IINV Interrupt configuration. Selects \overline{INT} pin behavior.
 00 = Low Logic Level When Asserted
 01 = High Logic Level When Asserted
 10 = Low-going Pulse on New Interrupt
 11 = High-going Pulse on New Interrupt

iCPU Inverts the CPUCLK output.
 0 = Default
 1 = Invert CPUCLK.

K[3:0] Clock divider. Divides MCLK by K to generate internal clock DCLK. (DCLK = MCLK/K). K is unsigned and in the range of 1 to 16. When zero, K = 16. At reset, K = 1.

8.2.2 Instantaneous Current ($I1$, $I2$), Voltage ($V1$, $V2$), and Power ($P1$, $P2$)

Address: 1 ($I1$), 2 ($V1$), 3 ($P2$), 7 ($I2$), 8 ($V2$), 9 ($P2$)

MSB										LSB					
$-(2^0)$	2^{-1}	2^{-2}	2^{-3}	2^{-4}	2^{-5}	2^{-6}	2^{-7}	2^{-17}	2^{-18}	2^{-19}	2^{-20}	2^{-21}	2^{-22}	2^{-23}

$I1$ ($I2$) and $V1$ ($V2$) contain instantaneous current and voltage, respectively, which are multiplied to yield instantaneous power, $P1$ ($P2$). These are two's complement values in the range of $-1.0 \leq \text{value} < 1.0$, with the binary point to the right of the MSB.

8.2.3 Active Power ($P1_{AVG}$, $P2_{AVG}$)

Address: 4 ($P1_{AVG}$), 10 ($P2_{AVG}$)

MSB										LSB					
$-(2^0)$	2^{-1}	2^{-2}	2^{-3}	2^{-4}	2^{-5}	2^{-6}	2^{-7}	2^{-17}	2^{-18}	2^{-19}	2^{-20}	2^{-21}	2^{-22}	2^{-23}

Instantaneous power is averaged over each low-rate interval (N samples) to compute active power, $P1_{AVG}$ ($P2_{AVG}$). These are two's complement values in the range of $-1.0 \leq \text{value} < 1.0$, with the binary point to the right of the MSB.

8.2.4 RMS Current ($I1_{RMS}$, $I2_{RMS}$) and Voltage ($V1_{RMS}$, $V2_{RMS}$)

Address: 5 ($I1_{RMS}$), 6 ($V1_{RMS}$), 11 ($I2_{RMS}$), 12 ($V2_{RMS}$)

MSB										LSB					
2^{-1}	2^{-2}	2^{-3}	2^{-4}	2^{-5}	2^{-6}	2^{-7}	2^{-8}	2^{-18}	2^{-19}	2^{-20}	2^{-21}	2^{-22}	2^{-23}	2^{-24}

$I1_{RMS}$ ($I2_{RMS}$) and $V1_{RMS}$ ($V2_{RMS}$) contain the root mean square (RMS) values of $I1$ ($I2$) and $V1$ ($V2$), calculated each low-rate interval. These are unsigned values in the range of $0 \leq \text{value} < 1.0$, with the binary point to the left of the MSB.

8.2.5 Instantaneous Quadrature Power ($Q1$, $Q2$)

Address: 14 ($Q1$), 17 ($Q2$)

MSB										LSB					
$-(2^0)$	2^{-1}	2^{-2}	2^{-3}	2^{-4}	2^{-5}	2^{-6}	2^{-7}	2^{-17}	2^{-18}	2^{-19}	2^{-20}	2^{-21}	2^{-22}	2^{-23}

Instantaneous quadrature power, $Q1$ ($Q2$), the product of voltage1 (voltage2) shifted 90 degrees and current1 (current2). These are two's complement values in the range of $-1.0 \leq \text{value} < 1.0$, with the binary point to the right of the MSB.

8.2.6 Reactive Power ($Q1_{AVG}$, $Q2_{AVG}$)

Address: 13 ($Q1_{AVG}$), 16 ($Q2_{AVG}$)

MSB										LSB					
$-(2^0)$	2^{-1}	2^{-2}	2^{-3}	2^{-4}	2^{-5}	2^{-6}	2^{-7}	2^{-17}	2^{-18}	2^{-19}	2^{-20}	2^{-21}	2^{-22}	2^{-23}

Reactive power $Q1_{AVG}$ ($Q2_{AVG}$) is $Q1$ ($Q2$) averaged over every N samples. These are two's complement values in the range of $-1.0 \leq \text{value} < 1.0$, with the binary point to the right of the MSB.

8.2.7 Peak Current ($I1_{PEAK}$, $I2_{PEAK}$) and Peak Voltage ($V1_{PEAK}$, $V2_{PEAK}$)

Address: 18 ($I1_{PEAK}$), 19 ($V1_{PEAK}$), 22 ($I2_{PEAK}$), 23 ($V2_{PEAK}$)

MSB														LSB	
$-(2^0)$	2^{-1}	2^{-2}	2^{-3}	2^{-4}	2^{-5}	2^{-6}	2^{-7}	2^{-17}	2^{-18}	2^{-19}	2^{-20}	2^{-21}	2^{-22}	2^{-23}

Peak current, $I1_{PEAK}$ ($I2_{PEAK}$) and peak voltage, $V1_{PEAK}$ ($V2_{PEAK}$) are the instantaneous current and voltage samples with the greatest magnitude detected during the last low-rate interval. These are two's complement values in the range of $-1.0 \leq \text{value} < 1.0$, with the binary point to the right of the MSB.

8.2.8 Apparent Power ($S1$, $S2$)

Address: 20 ($S1$), 24 ($S2$)

MSB														LSB	
$-(2^0)$	2^{-1}	2^{-2}	2^{-3}	2^{-4}	2^{-5}	2^{-6}	2^{-7}	2^{-17}	2^{-18}	2^{-19}	2^{-20}	2^{-21}	2^{-22}	2^{-23}

Apparent power $S1$ ($S2$) is the product of $V1_{RMS}$ and $I1_{RMS}$ ($V2_{RMS}$ and $I2_{RMS}$). These are two's complement values in the range of $0 \leq \text{value} < 1.0$, with the binary point to the right of the MSB.

8.2.9 Power Factor ($PF1$, $PF2$)

Address: 21 ($PF1$), 25 ($PF2$)

MSB														LSB	
$-(2^0)$	2^{-1}	2^{-2}	2^{-3}	2^{-4}	2^{-5}	2^{-6}	2^{-7}	2^{-17}	2^{-18}	2^{-19}	2^{-20}	2^{-21}	2^{-22}	2^{-23}

Power factor is calculated by dividing active power by apparent power. The sign is determined by the active power sign. These are two's complement values in the range of $-1.0 \leq \text{value} < 1.0$, with the binary point to the right of the MSB.

8.2.10 Temperature (T) – Address: 27

MSB										LSB					
$-(2^7)$	2^6	2^5	2^4	2^3	2^2	2^1	2^0	2^{-10}	2^{-11}	2^{-12}	2^{-13}	2^{-14}	2^{-15}	2^{-16}

T contains results from the on-chip temperature measurement. By default, T uses the Celsius scale, and is a two's complement value in the range of $-128.0 \leq \text{value} < 128.0$ ($^{\circ}\text{C}$), with the binary point to the right of bit 16.

T can be rescaled by the application using the T_{GAIN} and T_{OFF} registers.

8.2.11 Active, Apparent, and Reactive Energy Pulse Outputs (E_{PULSE} , S_{PULSE} , Q_{PULSE})

Address: 29 (E_{PULSE}), 30 (S_{PULSE}), 31 (Q_{PULSE})

MSB														LSB	
$-(2^0)$	2^{-1}	2^{-2}	2^{-3}	2^{-4}	2^{-5}	2^{-6}	2^{-7}	2^{-17}	2^{-18}	2^{-19}	2^{-20}	2^{-21}	2^{-22}	2^{-23}

These drive the pulse outputs when configured to do so. If the $lchan$ bit in $Modes$ is "0", these registers are driven from $P1_{AVG}$, $S1$, and $Q1_{AVG}$, respectively. If the $lchan$ bit is "1", these registers are driven from $P2_{AVG}$, $S2$, and $Q2_{AVG}$, respectively. These are two's complement values in the range of $-1.0 \leq \text{value} < 1.0$, with the binary point to the right of the MSB.

8.2.12 Internal Status (Status) and Interrupt Mask (Mask)

 Address: 15 (*Status*); 26 (*Mask*)

23	22	21	20	19	18	17	16
DRDY	I2OR	V2OR	CRDY	I2ROR	V2ROR	I1OR	V1OR
15	14	13	12	11	10	9	8
E2OR	I1ROR	V1ROR	E1OR	I1FAULT	V1SAG	I2FAULT	V2SAG
7	6	5	4	3	2	1	0
TUP	TOD	I2OD	VOD	I1OD	LSD	FUP	\overline{IC}

 Default = 1 (*Status*), 0 (*Mask*)

The *Status* register indicates a variety of conditions within the chip. Writing a '1' to a *Status* register bit will clear that bit if the condition that set it has been removed. Writing a '0' to any bit has no effect.

The *Mask* register is used to control the activation of the \overline{INT} pin. Placing a logic '1' to a *Mask* register bit will allow the corresponding *Status* register bit to activate the \overline{INT} pin when set.

DRDY	Data Ready. During conversion, this bit indicates that low-rate results have been updated. It indicates completion of other commands and the reset sequence.
I1OR (I2OR)	Current Out of Range. Set when the measured current would cause the <i>I1</i> (<i>I2</i>) register to overflow.
V1OR (V2OR)	Voltage Out of Range. Set when the measured voltage would cause the <i>V1</i> (<i>V2</i>) register to overflow.
CRDY	Conversion Ready. Indicates that sample rate (output word rate) results have been updated.
I1ROR (I2ROR)	RMS Current Out of Range. Set when RMS current would cause the <i>I1_{RMS}</i> (<i>I2_{RMS}</i>) register to overflow.
V1ROR (V2ROR)	RMS Voltage Out of Range. Set when RMS voltage would cause the <i>V1_{RMS}</i> (<i>V2_{RMS}</i>) register to overflow.
E1OR (E2OR)	Energy Out of Range. Set when average power would cause <i>P1_{AVG}</i> (<i>P2_{AVG}</i>) to overflow.
I1FAULT (I2FAULT)	Indicates when a current fault condition has occurred.
V1SAG (V2SAG)	Indicates when a voltage sag condition has occurred.
TUP	Indicates when the Temperature register (<i>T</i>) has been updated.
TOD	Modulator oscillation has been detected in the temperature A/D.
VOD	Modulator oscillation has been detected in the voltage A/D.
I1OD (I2OD)	Modulator oscillation has been detected in the current1 (current2) A/D.
LSD	Low Supply Detect. Set when the voltage on the PFMON pin falls below the specified low level. LSD bit cannot be reset until the voltage rises above the specified high level.
FUP	Frequency Updated. Indicates the <i>Epsilon</i> register has been updated.
\overline{IC}	Invalid Command. Normally logic 1. Set to 0 when an invalid command is received. It may also indicate loss of serial command synchronization and the part may need to be re-initialized.

8.2.13 Control (Ctrl) – Address: 28

23	22	21	20	19	18	17	16
PC7	PC6	PC5	PC4	PC3	PC2	PC1	PC0
15	14	13	12	11	10	9	8
-	-	-	I2gain	-	-	-	STOP
7	6	5	4	3	2	1	0
-	-	I1gain	INTOD	-	NOCPU	NOOSC	-

Default = 0

PC[7:0] Phase compensation for channel 2. Sets a delay in voltage relative to current. Phase is signed and in the range of $-1.0 \leq \text{value} < 1.0$ sample (OWR) intervals.

I1gain (I2gain) Sets the gain of the current1 (current2) input.
 0 = Gain is set for $\pm 250\text{mV}$ range.
 1 = Gain is set for $\pm 50\text{mV}$ range.

STOP Terminates E²PROM command sequence (if used).
 0 = No Action
 1 = Stop E²PROM Commands.

INTOD Converts $\overline{\text{INT}}$ output pin to an open drain output.
 0 = Normal Output
 1 = Open-drain Output

NOCPU Saves power by disabling the CPUCLK output pin.
 0 = CPUCLK Enabled
 1 = CPUCLK Disabled

NOOSC Disables the crystal oscillator, making XIN a logic-level input.
 0 = Crystal Oscillator Enabled
 1 = Crystal Oscillator Disabled

8.3 Page 1 Registers

8.3.1 DC Offset for Current ($I1_{OFF}$, $I2_{OFF}$) and Voltage ($V1_{OFF}$, $V2_{OFF}$)

Address: 0 ($I1_{OFF}$), 2 ($V1_{OFF}$), 7 ($I2_{OFF}$), 9 ($V2_{OFF}$)

MSB														LSB	
$-(2^0)$	2^{-1}	2^{-2}	2^{-3}	2^{-4}	2^{-5}	2^{-6}	2^{-7}	2^{-17}	2^{-18}	2^{-19}	2^{-20}	2^{-21}	2^{-22}	2^{-23}

Default = 0

DC offset registers $I1_{OFF}$ & $V1_{OFF}$ ($I2_{OFF}$ & $V2_{OFF}$) are initialized to zero on reset. During DC offset calibration, selected registers are written with the inverse of the DC offset measured. The application program can also write the DC offset register values. These are two's complement values in the range of $-1.0 \leq \text{value} < 1.0$, with the binary point to the right of the MSB.

8.3.2 Gain for Current ($I1_{GAIN}$, $I2_{GAIN}$) and Voltage ($V1_{GAIN}$, $V2_{GAIN}$)

Address: 1 ($I1_{GAIN}$), 3 ($V1_{GAIN}$), 8 ($I2_{GAIN}$), 10 ($V2_{GAIN}$)

MSB														LSB	
2^1	2^0	2^{-1}	2^{-2}	2^{-3}	2^{-4}	2^{-5}	2^{-6}	2^{-16}	2^{-17}	2^{-18}	2^{-19}	2^{-20}	2^{-21}	2^{-22}

Default = 1.0

Gain registers $I1_{GAIN}$ & $V1_{GAIN}$ ($I2_{GAIN}$ & $V2_{GAIN}$) are initialized to 1.0 on reset. During AC or DC gain calibration, selected register are written with the multiplicative inverse of the gain measured. These are unsigned fixed-point values in the range of $0 \leq \text{value} < 4.0$, with the binary point to the right of the second MSB.

8.3.3 Power Offset ($P1_{OFF}$, $P2_{OFF}$)

Address: 4 ($P1_{OFF}$), 11 ($P2_{OFF}$)

MSB														LSB	
$-(2^0)$	2^{-1}	2^{-2}	2^{-3}	2^{-4}	2^{-5}	2^{-6}	2^{-7}	2^{-17}	2^{-18}	2^{-19}	2^{-20}	2^{-21}	2^{-22}	2^{-23}

Default = 0

Power offset $P1_{OFF}$ ($P2_{OFF}$) is added to instantaneous power and averaged over a low-rate interval to yield $P1_{AVG}$ ($P2_{AVG}$) register results. It can be used to reduce systematic energy errors. These are two's complement values in the range of $-1.0 \leq \text{value} < 1.0$, with the binary point to the right of the MSB.

8.3.4 AC Offset for Current ($I1_{ACOFF}$, $I2_{ACOFF}$) and Voltage ($V1_{ACOFF}$, $V2_{ACOFF}$)

Address: 5 ($I1_{ACOFF}$), 6 ($V1_{ACOFF}$), 12 ($I2_{ACOFF}$), 13 ($V2_{ACOFF}$)

MSB														LSB	
$-(2^0)$	2^{-1}	2^{-2}	2^{-3}	2^{-4}	2^{-5}	2^{-6}	2^{-7}	2^{-17}	2^{-18}	2^{-19}	2^{-20}	2^{-21}	2^{-22}	2^{-23}

Default = 0

AC offset registers $I1_{ACOFF}$ & $V1_{ACOFF}$ (V_{ACOFF} & $V2_{ACOFF}$) are initialized to zero on reset. These are added to the RMS results before being stored to the RMS result registers. They can be used to reduce systematic errors in the RMS results. These are two's complement values in the range of $-1.0 \leq \text{value} < 1.0$, with the binary point to the right of the MSB.

8.3.5 Mode Control (Modes) – Address: 16

23	22	21	20	19	18	17	16
Ichan	VFIX	-	-	-	-	-	-
15	14	13	12	11	10	9	8
IvsE	E1MODE1	E1MODE0	Ihold	-	E2MODE1	E2MODE0	VHPF2
7	6	5	4	3	2	1	0
IHPF2	VHPF1	IHPF1	-	E3MODE1	E3MODE0	POS	AFC

Default = 0

- Ichan Chooses an energy channel to drive the E_{PULSE} , S_{PULSE} , and Q_{PULSE} registers.
 0 = Pulse registers driven by energy channel 1.
 1 = Pulse registers driven by energy channel 2.
- VFIX Use internal RMS voltage reference instead of voltage input for average active power.
 0 = Use voltage input.
 1 = Use Internal RMS voltage reference, V_{RMS} .
- IvsE Use I_{RMS} results instead of P_{AVG} for energy channel selection
 0 = Use $P1_{AVG}$ and $P2_{AVG}$ instead of $I1_{RMS}$ and $I2_{RMS}$.
 1 = Use $I1_{RMS}$ and $I2_{RMS}$ instead of $P1_{AVG}$ and $P2_{AVG}$.
- E1MODE[1:0] $\overline{E1}$, $\overline{E2}$, and $\overline{E3}$ alternate Output Mode (when enabled by E2MODE)
 00 = $\overline{E1}$, $\overline{E2}$ = $P1_{AVG}$, $P2_{AVG}$
 01 = $\overline{E1}$, $\overline{E2}$ = $S1$, $S2$
 10 = $\overline{E1}$, $\overline{E2}$ = $Q1_{AVG}$, $Q2_{AVG}$
 11 = $\overline{E1}$, $\overline{E2}$ = $Q1_{WB}$, $Q2_{WB}$
- Ihold Suspends automatic channel selection.
 0 = Channel selected automatically by magnitude compare.
 1 = Channel selected by application (host).
- E2MODE[1:0] $\overline{E2}$ Output Mode
 00 = Energy Sign
 01 = Apparent Energy
 10 = Channel In Use
 11 = Enable E1MODE
- VHPF2:IHPF2 High-pass Filter Enable for Energy Channel 2
 00 = No Filter
 01 = HPF on Current, PMF on Voltage
 10 = HPF on Voltage, PMF on Current
 11 = HPF on both Voltage and Current
- VHPF1:IHPF1 High-pass Filter Enable for Energy Channel1
 00 = No Filter
 01 = HPF on Current, PMF on Voltage
 10 = HPF on Voltage, PMF on Current
 11 = HPF on both Voltage and Current
- E3MODE[1:0] $\overline{E3}$ Output Mode (**with E1MODE disabled**)
 00 = Reactive Energy (default)
 01 = Power Fail Monitor
 10 = Voltage Sign
 11 = Apparent Energy

- E3MODE[1:0] $\overline{\text{E3}}$ Output Mode (**with E1MODE enabled**)
 00 = Power Fail Monitor
 01 = Energy Sign
 10 = not used
 11 = not used
- POS Positive Energy Only. Suppresses negative values in $P1_{AVG}$ and $P2_{AVG}$. If a negative value is calculated, zero will be stored instead.
- AFC Enables automatic line frequency measurement which sets *Epsilon* every time a new line frequency measurement completes. *Epsilon* is used to control the gain of the 90 degree phase shift integrator used in quadrature power calculations.

8.3.6 Line to Sample Frequency Ratio (*Epsilon*) – Address: 17

MSB										LSB					
$-(2^0)$	2^{-1}	2^{-2}	2^{-3}	2^{-4}	2^{-5}	2^{-6}	2^{-7}	2^{-17}	2^{-18}	2^{-19}	2^{-20}	2^{-21}	2^{-22}	2^{-23}

Default = 0.0125 (4.0 kHz x 0.0125 or 50 Hz)

Epsilon is the ratio of the input line frequency to the output word rate (OWR). It can either be written by the application program or calculated automatically from the line frequency (from the voltage input) using the AFC bit in the *Modes* register. It is a two's complement value in the range of $-1.0 \leq \text{value} < 1.0$, with the binary point to the right of the MSB. Negative values are not used.

8.3.7 Pulse Output Width (*PulseWidth*) – Address: 14

MSB										LSB					
0	2^{22}	2^{21}	2^{20}	2^{19}	2^{18}	2^{17}	2^{16}	2^6	2^5	2^4	2^3	2^2	2^1	2^0

Default = 1 (250 uS at OWR = 4 kHz)

PulseWidth sets the duration of energy pulses. The actual pulse duration is the contents of *PulseWidth* divided by the output word rate (OWR). *PulseWidth* is an integer in the range of 1 to 8,388,607.

8.3.8 Pulse Output Rate (*PulseRate*) – Address: 15

MSB										LSB					
$-(2^0)$	2^{-1}	2^{-2}	2^{-3}	2^{-4}	2^{-5}	2^{-6}	2^{-7}	2^{-17}	2^{-18}	2^{-19}	2^{-20}	2^{-21}	2^{-22}	2^{-23}

Default= -1

PulseRate sets the full-scale frequency for $\overline{\text{E1}}$, $\overline{\text{E2}}$, $\overline{\text{E3}}$ pulse outputs. For a 4 kHz sample rate, the maximum pulse rate is 2 kHz. This is a two's complement value in the range of $-1 \leq \text{value} < 1$, with the binary point to the left of the MSB.

Refer to [6.10 Energy Pulse Rate](#) on page 20 for more information.

8.3.9 Cycle Count (N) – Address: 19

MSB									LSB						
0	2^{22}	2^{21}	2^{20}	2^{19}	2^{18}	2^{17}	2^{16}	2^6	2^5	2^4	2^3	2^2	2^1	2^0

Default = 4000

Determines the number of output word rate (OWR) samples to use in calculating low-rate results. Cycle Count (N) is an integer in the range of 10 to 8,388,607. Values less than 10 should not be used.

8.3.10 Channel Select Level (I_{chan_level}) – Address: 18

MSB									LSB						
2^0	2^{-1}	2^{-2}	2^{-3}	2^{-4}	2^{-5}	2^{-6}	2^{-7}	2^{-17}	2^{-18}	2^{-19}	2^{-20}	2^{-21}	2^{-22}	2^{-23}

Default = 1.02 (minimum difference = 2%)

Sets the hysteresis level for energy channel selection. If the most positive value of $P1_{AVG}$ and $P2_{AVG}$ ($I1_{RMS}$ and $I2_{RMS}$) is greater than I_{chan_LEVEL} multiplied by the least-positive value, and is also greater than I_{chan_MIN} , the channel associated with the most-positive value will be used. If not, the previous channel selection will remain. I_{chan_LEVEL} is an unsigned fixed-point value in the range of $0 \leq \text{value} < 2.0$, with the binary point to the left of the MSB. A value of 1.0 or less indicates no hysteresis will be used.

8.3.11 Channel Select Minimum Amplitude (E_{MIN} or I_{rms_MIN}) – Address: 24

MSB									LSB						
$-(2^0)$	2^{-1}	2^{-2}	2^{-3}	2^{-4}	2^{-5}	2^{-6}	2^{-7}	2^{-17}	2^{-18}	2^{-19}	2^{-20}	2^{-21}	2^{-22}	2^{-23}

Default = 0.003

Sets the minimum level for energy channel selection. If the most positive value of $P1_{AVG}$ and $P2_{AVG}$ ($I1_{RMS}$ and $I2_{RMS}$) is less than I_{chan_MIN} then the previous channel selection will remain in use. It is a two's complement value in the range of $-1.0 \leq \text{value} < 1.0$, with the binary point to the right of the MSB. Negative values are not used.

8.3.12 Wideband Reactive Power ($Q1_{WB}$, $Q2_{WB}$)

Address: 20 ($Q1_{WB}$), 21 ($Q2_{WB}$)

MSB									LSB						
$-(2^0)$	2^{-1}	2^{-2}	2^{-3}	2^{-4}	2^{-5}	2^{-6}	2^{-7}	2^{-17}	2^{-18}	2^{-19}	2^{-20}	2^{-21}	2^{-22}	2^{-23}

Wideband reactive power is calculated using vector subtraction. (See [Section 4.8 Power and Energy Results](#) on page 16). The value is signed, but has a range of $0 \leq \text{value} < 1.0$. The binary point is to the right of the MSB.

8.3.13 Temperature Gain (T_{GAIN}) – Address: 22

MSB									LSB						
2^6	2^5	2^4	2^3	2^2	2^1	2^0	2^{-1}	2^{-11}	2^{-12}	2^{-13}	2^{-14}	2^{-15}	2^{-16}	2^{-17}

Default = 0x2F02C3

Refer to [6.13 Temperature Measurement](#) on page 21 for more information.

8.3.14 Temperature Offset (T_{OFF}) – Address: 23

MSB									LSB						
$-(2^0)$	2^{-1}	2^{-2}	2^{-3}	2^{-4}	2^{-5}	2^{-6}	2^{-7}	2^{-17}	2^{-18}	2^{-19}	2^{-20}	2^{-21}	2^{-22}	2^{-23}

Default = 0xF3D35A

Refer to [6.13 Temperature Measurement](#) on page 21 for more information.

8.3.15 Filter Settling Time for Conversion Startup (T_{SETTLE}) – Address: 25

MSB									LSB						
2^{23}	2^{22}	2^{21}	2^{20}	2^{19}	2^{18}	2^{17}	2^{16}	2^6	2^5	2^4	2^3	2^2	2^1	2^0

Default = 30

Sets the number of output word rate (OWR) samples that will be used to allow filters to settle at the beginning of Conversion and Calibration commands. This is an integer in the range of 0 to 8,388,607 samples.

8.3.16 No Load Threshold ($Load_{MIN}$) – Address 26

MSB									LSB						
$-(2^0)$	2^{-1}	2^{-2}	2^{-3}	2^{-4}	2^{-5}	2^{-6}	2^{-7}	2^{-17}	2^{-18}	2^{-19}	2^{-20}	2^{-21}	2^{-22}	2^{-23}

Default = 0

$Load_{MIN}$ is used to set the no load threshold. When the magnitude of the E_{PULSE} register is less than $Load_{MIN}$, E_{PULSE} will be zeroed. If the magnitude of the Q_{PULSE} register is less than $Load_{MIN}$, Q_{pulse} will be zeroed.

$Load_{MIN}$ is a two's complement value in the range of $-1.0 \leq \text{value} < 1.0$, with the binary point to the right of the MSB. Negative values are not used.

8.3.17 Voltage Fixed RMS Reference ($V_{F_{RMS}}$) – Address 27

MSB									LSB						
$-(2^0)$	2^{-1}	2^{-2}	2^{-3}	2^{-4}	2^{-5}	2^{-6}	2^{-7}	2^{-17}	2^{-18}	2^{-19}	2^{-20}	2^{-21}	2^{-22}	2^{-23}

Default = 0.7071068 (full scale RMS)

If the application program detects that the meter has possibly been tampered with in such a manner that the voltage input is no longer working, it may choose to use this internal RMS reference instead of the disabled voltage input by setting the VFIX bit in the Modes register. This is a two's complement value in the range of $0 \leq \text{value} < 1.0$, with the binary point to the right of the MSB. Negative values are not used.

8.3.18 System Gain (G) – Address: 28

MSB								LSB							
$-(2^1)$	2^0	2^{-1}	2^{-2}	2^{-3}	2^{-4}	2^{-5}	2^{-6}	2^{-16}	2^{-17}	2^{-18}	2^{-19}	2^{-20}	2^{-21}	2^{-22}

Default = 1.25

System Gain (G) is applied to all channels. By default, $G = 1.25$, but can be finely adjusted to compensate for voltage reference error. It is a two's complement value in the range of $-2.0 \leq \text{value} < 2.0$, with the binary point to the right of the second MSB. Values should be kept within 5% of 1.25.

8.3.19 System Time (Time) – Address: 29

MSB								LSB							
2^{23}	2^{22}	2^{21}	2^{20}	2^{19}	2^{18}	2^{17}	2^{16}	2^6	2^5	2^4	2^3	2^2	2^1	2^0

Default = 0

System Time (*Time*) is measured in output word rate (OWR) samples. This is an unsigned integer in the range of 0 to 16,777,215 samples. At 4.0 kHz, OWR it will overflow every 1 hour, 9 minutes, and 54 seconds. *Time* can be used by the application to manage real-time events.

8.4 Page 2 Registers
8.4.1 Voltage Sag and Current Fault Duration ($V1Sag_{DUR}$, $V2Sag_{DUR}$, $I1Fault_{DUR}$, $I2Fault_{DUR}$)
 Address: 0 ($V1Sag_{DUR}$), 8 ($V2Sag_{DUR}$), 4 ($I1Fault_{DUR}$), 12 ($I2Fault_{DUR}$)

MSB								LSB							
0	2^{22}	2^{21}	2^{20}	2^{19}	2^{18}	2^{17}	2^{16}	2^6	2^5	2^4	2^3	2^2	2^1	2^0

Default = 0

Voltage sag duration, $V1Sag_{DUR}$ ($V2Sag_{DUR}$) and current fault duration, $I1Fault_{DUR}$ ($I2Fault_{DUR}$) determine the count of output word rate (OWR) samples utilized to determine a sag or fault event. These are integers in the range of 0 to 8,388,607 samples. A value of zero disables the feature.

8.4.2 Voltage Sag and Current Fault Level ($V1Sag_{LEVEL}$, $V2Sag_{LEVEL}$, $I1Fault_{LEVEL}$, $I2Fault_{LEVEL}$)
 Address: 1 ($V1Sag_{LEVEL}$), 9 ($V2Sag_{LEVEL}$), 5 ($I1Fault_{LEVEL}$), 13 ($I2Fault_{LEVEL}$)

MSB								LSB							
$-(2^0)$	2^{-1}	2^{-2}	2^{-3}	2^{-4}	2^{-5}	2^{-6}	2^{-7}	2^{-17}	2^{-18}	2^{-19}	2^{-20}	2^{-21}	2^{-22}	2^{-23}

Default = 0

Voltage sag level, $V1Sag_{LEVEL}$ ($V2Sag_{LEVEL}$) and current fault level, $I1Fault_{LEVEL}$ ($I2Fault_{LEVEL}$) establish an input level below which a sag or fault is triggered. These are two's complement values in the range of $-1.0 \leq \text{value} < 1.0$, with the binary point to the right of the MSB. Negative values are not used.

9. SYSTEM CALIBRATION

9.1 Calibration

The CS5464 provides DC offset and gain calibration that can be applied to the voltage and current measurements, and AC offset calibration which can be applied to the voltage and current RMS calculations.

Since the voltage and current channels have independent offset and gain registers, offset and gain calibration can be performed on any channel independently.

The data flow of the calibration is shown in Figure 10.

The CS5464 must be operating in its active state and ready to accept valid commands. Refer to 7.6 *Commands* on page 24.

The value in the Cycle Count register (N) determines the number of output word rate (OWR) samples that are averaged during a calibration. DC offset and gain calibrations take at least $N + T_{SETTLE}$ samples. AC offset calibrations take at least $6(N) + T_{SETTLE}$ samples. As N is increased, the accuracy of calibration results tends to also increase.

The DRDY bit in the *Status* register will be set at the completion of Calibration commands. If an overflow occurs during calibration, other *Status* register bits may be set as well.

9.1.1 Offset Calibration

During offset calibrations, no line voltage or current should be applied to the meter. A zero-volt differential signal can also be applied to the voltage inputs VIN_{\pm} or current inputs $IIN1_{\pm}$ ($IIN2_{\pm}$) of the CS5464.

(see Figure 11.)

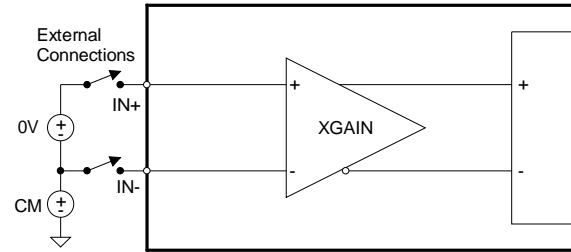

Figure 11. System Calibration of Offset

9.1.1.1 DC Offset Calibration

The DC Offset Calibration command measures and averages DC values read on specified voltage or current channels at zero input and stores the inverse result in the associated offset registers. This will be added to instantaneous measurements in subsequent conversions, removing the offset.

Gain registers for channels being calibrated should be set to 1.0 prior to performing DC offset calibration.

9.1.1.2 AC Offset Calibration

The AC Offset Calibration command measures the residual RMS values read on specified voltage or current channels at zero input and stores the inverse result in the associated AC offset registers. This will be added to RMS measurements in subsequent conversions, removing the offset.

AC offset registers for channels being calibrated should first be cleared prior to performing the calibration.

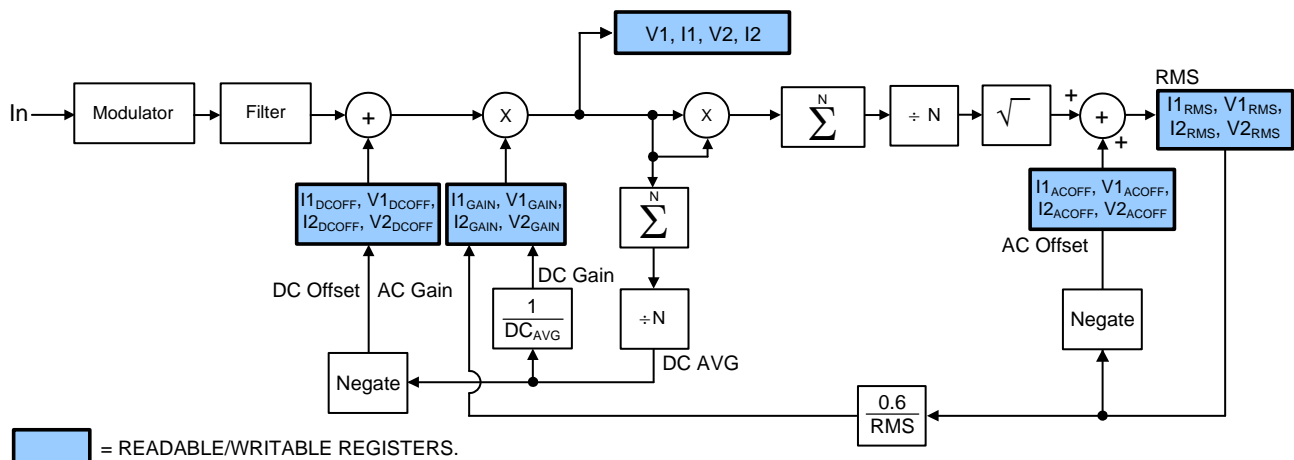

Figure 10. Calibration Data Flow

9.1.2 Gain Calibration

During gain calibration, a full-scale reference signal must be applied to the meter or optionally, scaled to the VIN_{\pm} , $IIN1_{\pm}$ ($IIN2_{\pm}$) pins of the CS5464. A DC reference must be used for DC gain calibration. Either an AC or DC reference can be used for RMS AC calibrations. If DC is used, the associated high-pass filter (HPF) must be off.

Figure 12 shows the basic setup for gain calibration.

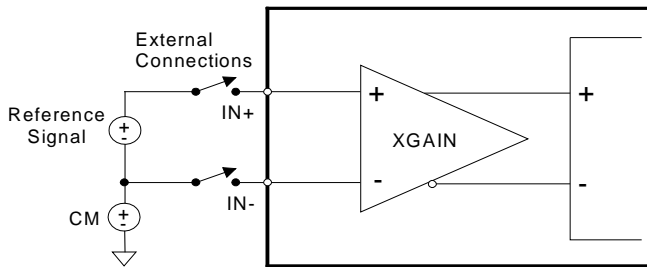

Figure 12. System Calibration of Gain.

Using a reference that is too large or too small can cause an over-range condition during calibration. Either condition can set *Status* register bits $I1OR$ ($I2OR$) $V1OR$ ($V2OR$) for DC and $I1ROR$ ($I2ROR$) $V1ROR$ ($V2ROR$) for AC calibration.

Full scale (FS) for the voltage input is $\pm 250\text{mV}$ peak and for the current inputs is $\pm 250\text{mV}$ or $\pm 50\text{mV}$ peak depending on selected gain range. The normal peak voltage applied to these pins should not exceed these levels during calibration or normal operation.

The range of the gain registers limits the gain calibration range and subsequently the range of the reference level that can be applied. The reference should not exceed FS or be lower than FS/4.

9.1.2.1 AC Gain Calibration

Full scale for AC RMS gain calibrations is 60% of the input's full-scale range, which is either 250mV or 50mV depending on the gain range selected. That's 150mV or 30mV, again depending on range. So the normal reference input level should be either 150 or 30 mV_{RMS} , AC or DC.

Prior to executing an AC Gain Calibration command, gain registers for any channel to be calibrated should be set to 1.0 if the reference level mentioned above is used, or to that level divided by the actual reference level used.

During AC gain calibration the RMS level of the applied reference is measured with the preset gain, then divided into 0.6 and the quotient stored back into the corresponding gain register.

9.1.2.2 DC Gain Calibration

With a DC reference applied, the DC Gain Calibration command measures and averages DC values read on the specified voltage or current channels and stores the reciprocal result in the associated gain registers, converting measured voltage into needed gain. Subsequent conversions will use the new gain value.

9.1.3 Calibration Order

1. DC offset.
2. DC or AC gain.
3. AC offset (if needed).

If both AC gain and offset calibrations were performed, it is possible to repeat both to obtain additional accuracy as AC gain and offset may interact.

9.1.4 Temperature Sensor Calibration

Temperature sensor calibration involves the adjustment of two parameters - ΔV_{BE} and V_{BE0} . These values must be known in order to calibrate the temperature sensor. See [Section 6.13 Temperature Measurement](#) on page 21 for an explanation of ΔV_{BE} and V_{BE0} and how to calculate T_{GAIN} and T_{OFF} register values from them.

9.1.4.1 Temperature Offset Calibration

Offset calibration can be done at any temperature, but should be done mid-scale if any gain error exists.

Subtract the measured T register temperature from the actual temperature to determine the offset error. Multiply this error by ΔV_{BE} and add it to V_{BE0} to yield a new V_{BE0} value. Recalculate T_{OFF} using this new value.

9.1.4.2 Temperature Gain Calibration

Two temperature points far enough apart to give reasonable accuracy, for example 25°C and 85°C, are required to calibrate temperature gain.

Divide the actual temperature difference by the measured (T register) difference for the two temperatures. This gives a gain correction factor. Update the T_{GAIN} register by multiplying its value by this correction factor.

Update ΔV_{BE} by dividing its old value by the gain correction factor. It will be needed for subsequent offset calibrations.

10. E²PROM OPERATION

The CS5464 can accept commands from a serial E²PROM connected to the serial interface instead of a host microcontroller. A high level (logic 1) on the MODE input indicates that an E²PROM is connected. This makes the \overline{CS} and SCLK pins become driven outputs. After reset and after running the initialization program, the CS5464 begins reading commands from the connected E²PROM.

10.1 E²PROM Configuration

A typical connection between the CS5464 and a E²PROM is shown in Figure 13.

The CS5464 asserts \overline{CS} (logic 0), clocks SCLK, and sends Read commands to the E²PROM on SDO.

Command format is identical to microcontroller mode, except the CS5464 will not attempt to write to the EE device. The command sequence stops when the STOP bit in the Control register (*Ctrl*) is written by the command sequence.

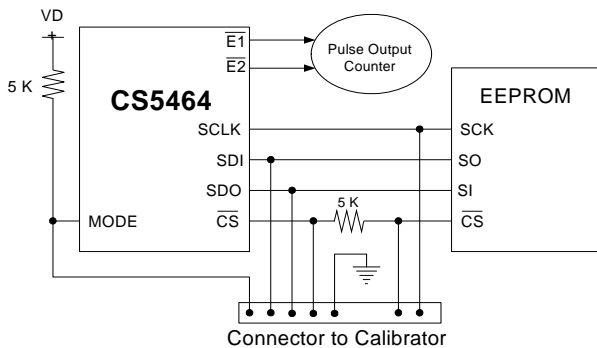

Figure 13. Typical Interface of E²PROM to CS5464

Figure 13 also shows the external connections that would be made to a calibration device, such as a notebook computer, handheld calibrator, or tester during meter assembly. The calibrator or tester can be used to control the CS5464 during calibration and program the required values into the E²PROM.

10.2 E²PROM Code

The EEPROM code should do the following:

1. Set any Configuration or Control register bits, such as HPF enables and phase compensation settings.
2. Write any calibration data to gain and offset registers.
3. Set energy output pulse width, rate, and formats.
4. Execute a Continuous Conversion command.
5. Set the STOP bit in the Control register (last).

Below is an example E²PROM code set.

```
-7E 00 00 01
  Change to page 1.
-60 00 01 E0
  Write Modes Register, turn high-pass filters on.
-42 7F C4 A9
  Write value of 0x7FC4A9 to I1_GAIN register.
-46 FF B2 53
  Write value of 0xFFB253 to V1_GAIN register.
-50 7F C4 A9
  Write value of 0x7FC4A9 to I2_GAIN register.
-54 FF B2 53
  Write value of 0xFFB253 to V2_GAIN register.
-7E 00 00 00
  Change to page 0.
-74 00 00 04
  Set LSD bit to 1 in the Mask register.
-E8
  Start continuous conversions
-78 00 01 00
  Write STOP bit to the Control register (Ctrl) to
  terminate E2PROM command sequence.
```

10.3 Which E²PROMs Can Be Used?

Several industry-standard serial E²PROMs can be used with the CS5464. Some are listed below:

- Atmel AT25010, AT25020 or AT25040
- National Semiconductor NM25C040M8 or NM25020M8
- Xicor X25040SI

These serial E²PROMs expect a specific 8-bit command (00000011) in order to perform a memory read. The CS5464 has been hardware programmed to transmit this 8-bit command to the E²PROM after reset.

11. BASIC APPLICATION CIRCUITS

Figure 14 shows the CS5464 configured to measure power in a single-phase, 2-wire system while operating in a single-supply configuration. In this diagram, a shunt resistor is used to sense the line current and a voltage divider is used to sense the line voltage. In this type of shunt-resistor configuration, the common-mode level of the CS5464 must be referenced to the line side of the

power line. This means that the common-mode potential of the CS5464 will track the high-voltage levels, as well as low-voltage levels, with respect to earth ground. Isolation circuitry is required when an earth-ground-referenced communication interface is connected. A current transformer (CT) is connected to the return line current, which implements the tamper detection circuit.

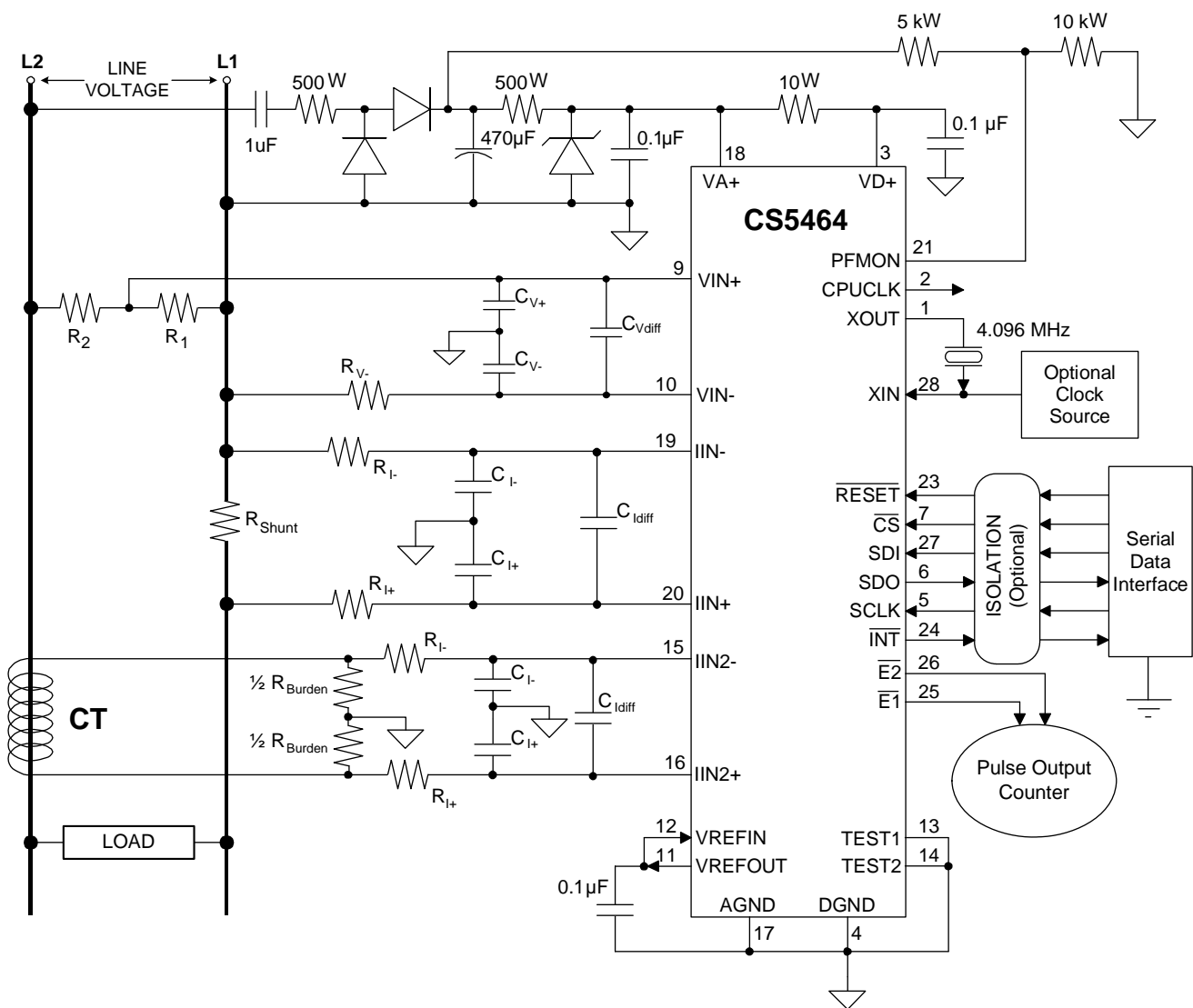
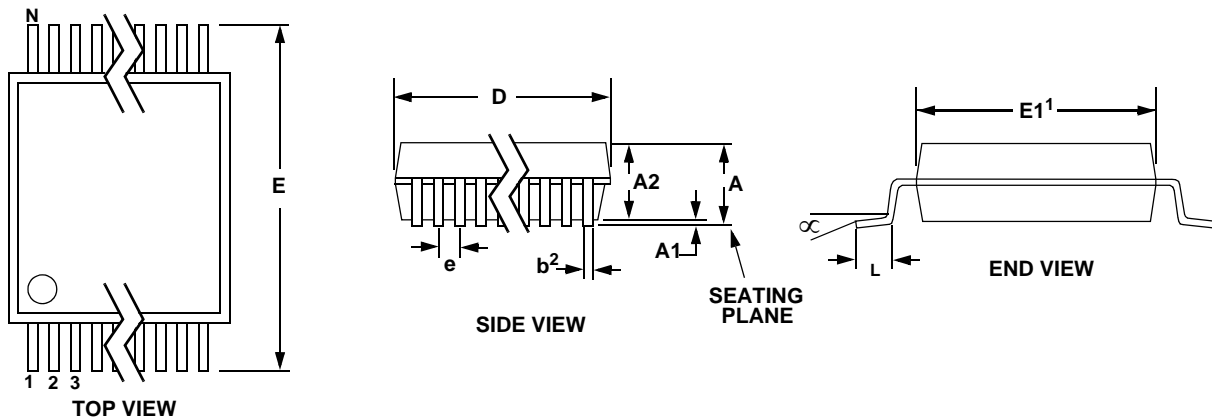

Figure 14. Typical Connection Diagram (Single-phase, 2-wire – Direct Connect to Power Line)

12. PACKAGE DIMENSIONS
28L SSOP PACKAGE DRAWING

DIM	INCHES			MILLIMETERS			NOTE
	MIN	NOM	MAX	MIN	NOM	MAX	
A	--	--	0.084	--	--	2.13	
A1	0.002	0.006	0.010	0.05	0.15	0.25	
A2	0.064	0.069	0.074	1.62	1.75	1.88	
b	0.009	--	0.015	0.22	--	0.38	2,3
D	0.390	0.4015	0.413	9.90	10.20	10.50	1
E	0.291	0.307	0.323	7.40	7.80	8.20	
E1	0.197	0.209	0.220	5.00	5.30	5.60	1
e	0.022	0.026	0.030	0.55	0.65	0.75	
L	0.025	0.0354	0.041	0.63	0.90	1.03	
∞	0°	4°	8°	0°	4°	8°	

JEDEC #: MO-150

Controlling Dimension is Millimeters

- Notes:
1. "D" and "E1" are reference datums and do not include mold flash or protrusions, but do include mold mismatch and are measured at the parting line, mold flash or protrusions shall not exceed 0.20 mm per side.
 2. Dimension "b" does not include dambar protrusion/intrusion. Allowable dambar protrusion shall be 0.13 mm total in excess of "b" dimension at maximum material condition. Dambar intrusion shall not reduce dimension "b" by more than 0.07 mm at least material condition.
 3. These dimensions apply to the flat section of the lead between 0.10 and 0.25 mm from lead tips.

13. ORDERING INFORMATION

Model	Temperature	Package
CS5464-ISZ (lead free)	-40 to +85 °C	28-pin SSOP

14. ENVIRONMENTAL, MANUFACTURING, & HANDLING INFORMATION

Model Number	Peak Reflow Temp	MSL Rating*	Max Floor Life
CS5464-ISZ (lead free)	260 °C	3	7 Days

* MSL (Moisture Sensitivity Level) as specified by IPC/JEDEC J-STD-020.

15. REVISION HISTORY

Revision	Date	Changes
T1	NOV 2005	Target Data Sheet
PP1	MAR 2006	Preliminary Release
PP2	JAN 2007	Update to correspond to rev C1 Silicon
F1	MAR 2007	Updated capitalization of register names for consistency with CS5467. Updated Typical Connection diagram. Updated Phase Compensation Range from $\pm 2.8^\circ$ to $\pm 5.4^\circ$. Updated document number to F1 for quality process level (QPL).
F2	JAN 2010	Increased on-chip reference temperature coefficient from 25 ppm / $^\circ\text{C}$ typ. to 40 ppm / $^\circ\text{C}$ typ.
F3	APR 2011	Removed lead-containing (Pb) device ordering information.

Contacting Cirrus Logic Support

For all product questions and inquiries contact a Cirrus Logic Sales Representative.

To find the one nearest to you go to www.cirrus.com

IMPORTANT NOTICE

Cirrus Logic, Inc. and its subsidiaries ("Cirrus") believe that the information contained in this document is accurate and reliable. However, the information is subject to change without notice and is provided "AS IS" without warranty of any kind (express or implied). Customers are advised to obtain the latest version of relevant information to verify, before placing orders, that information being relied on is current and complete. All products are sold subject to the terms and conditions of sale supplied at the time of order acknowledgment, including those pertaining to warranty, indemnification, and limitation of liability. No responsibility is assumed by Cirrus for the use of this information, including use of this information as the basis for manufacture or sale of any items, or for infringement of patents or other rights of third parties. This document is the property of Cirrus and by furnishing this information, Cirrus grants no license, express or implied under any patents, mask work rights, copyrights, trademarks, trade secrets or other intellectual property rights. Cirrus owns the copyrights associated with the information contained herein and gives consent for copies to be made of the information only for use within your organization with respect to Cirrus integrated circuits or other products of Cirrus. This consent does not extend to other copying such as copying for general distribution, advertising or promotional purposes, or for creating any work for resale.

CERTAIN APPLICATIONS USING SEMICONDUCTOR PRODUCTS MAY INVOLVE POTENTIAL RISKS OF DEATH, PERSONAL INJURY, OR SEVERE PROPERTY OR ENVIRONMENTAL DAMAGE ("CRITICAL APPLICATIONS"). CIRRUS PRODUCTS ARE NOT DESIGNED, AUTHORIZED OR WARRANTED FOR USE IN PRODUCTS SURGICALLY IMPLANTED INTO THE BODY, AUTOMOTIVE SAFETY OR SECURITY DEVICES, LIFE SUPPORT PRODUCTS OR OTHER CRITICAL APPLICATIONS. INCLUSION OF CIRRUS PRODUCTS IN SUCH APPLICATIONS IS UNDERSTOOD TO BE FULLY AT THE CUSTOMER'S RISK AND CIRRUS DISCLAIMS AND MAKES NO WARRANTY, EXPRESS, STATUTORY OR IMPLIED, INCLUDING THE IMPLIED WARRANTIES OF MERCHANTABILITY AND FITNESS FOR PARTICULAR PURPOSE, WITH REGARD TO ANY CIRRUS PRODUCT THAT IS USED IN SUCH A MANNER. IF THE CUSTOMER OR CUSTOMER'S CUSTOMER USES OR PERMITS THE USE OF CIRRUS PRODUCTS IN CRITICAL APPLICATIONS, CUSTOMER AGREES, BY SUCH USE, TO FULLY INDEMNIFY CIRRUS, ITS OFFICERS, DIRECTORS, EMPLOYEES, DISTRIBUTORS AND OTHER AGENTS FROM ANY AND ALL LIABILITY, INCLUDING ATTORNEYS' FEES AND COSTS, THAT MAY RESULT FROM OR ARISE IN CONNECTION WITH THESE USES.

Cirrus Logic, Cirrus, and the Cirrus Logic logo designs are trademarks of Cirrus Logic, Inc. All other brand and product names in this document may be trademarks or service marks of their respective owners.

Looking for pricing, stock, or lifecycle information?

Click below to explore more details on WIN SOURCE:

 [View CS5464-ISZ on WIN SOURCE](#)

 [Cirrus Logic Inc. Information](#)

Optimize Your Supply Chain with WIN SOURCE Solutions

-  Global Sourcing Solution
-  Obsolete Management
-  Cost Control Management
-  Shortage Management
-  Alternative Solution
-  Excess Inventory Management