



**THE DATASHEET OF  
EP4CE115F23C8LN**





# **Cyclone IV Device Handbook,**

---

## **Volume 1**



101 Innovation Drive  
San Jose, CA 95134  
[www.altera.com](http://www.altera.com)

CYIV-5V1-2.2

© 2016 Altera Corporation. All rights reserved. ALTERA, ARRIA, CYCLONE, HARDCOPY, MAX, MEGACORE, NIOS, QUARTUS and STRATIX words and logos are trademarks of Altera Corporation and registered in the U.S. Patent and Trademark Office and in other countries. All other words and logos identified as trademarks or service marks are the property of their respective holders as described at [www.altera.com/common/legal.html](http://www.altera.com/common/legal.html). Altera warrants performance of its semiconductor products to current specifications in accordance with Altera's standard warranty, but reserves the right to make changes to any products and services at any time without notice. Altera assumes no responsibility or liability arising out of the application or use of any information, product, or service described herein except as expressly agreed to in writing by Altera. Altera customers are advised to obtain the latest version of device specifications before relying on any published information and before placing orders for products or services.



<b>Chapter Revision Dates</b> .....	ix
-------------------------------------	----

## Additional Information

How to Contact Altera .....	Info-1
Typographic Conventions .....	Info-1

## Section I. Device Core

### Chapter 1. Cyclone IV FPGA Device Family Overview

Cyclone IV Device Family Features .....	1-1
Device Resources .....	1-3
Package Matrix .....	1-5
Cyclone IV Device Family Speed Grades .....	1-7
Cyclone IV Device Family Architecture .....	1-8
FPGA Core Fabric .....	1-8
I/O Features .....	1-9
Clock Management .....	1-9
External Memory Interfaces .....	1-9
Configuration .....	1-10
High-Speed Transceivers (Cyclone IV GX Devices Only) .....	1-10
Hard IP for PCI Express (Cyclone IV GX Devices Only) .....	1-11
Reference and Ordering Information .....	1-12
Document Revision History .....	1-13

### Chapter 2. Logic Elements and Logic Array Blocks in Cyclone IV Devices

Logic Elements .....	2-1
LE Features .....	2-2
LE Operating Modes .....	2-3
Normal Mode .....	2-3
Arithmetic Mode .....	2-4
Logic Array Blocks .....	2-5
Topology .....	2-5
LAB Interconnects .....	2-6
LAB Control Signals .....	2-6
Document Revision History .....	2-7

### Chapter 3. Memory Blocks in Cyclone IV Devices

Overview .....	3-1
Control Signals .....	3-3
Parity Bit Support .....	3-3
Byte Enable Support .....	3-3
Packed Mode Support .....	3-4
Address Clock Enable Support .....	3-5
Mixed-Width Support .....	3-6
Asynchronous Clear .....	3-7
Memory Modes .....	3-7
Single-Port Mode .....	3-8
Simple Dual-Port Mode .....	3-9

True Dual-Port Mode .....	3-11
Shift Register Mode .....	3-12
ROM Mode .....	3-13
FIFO Buffer Mode .....	3-13
Clocking Modes .....	3-14
Independent Clock Mode .....	3-14
Input or Output Clock Mode .....	3-14
Read or Write Clock Mode .....	3-15
Single-Clock Mode .....	3-15
Design Considerations .....	3-15
Read-During-Write Operations .....	3-15
Same-Port Read-During-Write Mode .....	3-16
Mixed-Port Read-During-Write Mode .....	3-16
Conflict Resolution .....	3-17
Power-Up Conditions and Memory Initialization .....	3-18
Power Management .....	3-18
Document Revision History .....	3-18
<b>Chapter 4. Embedded Multipliers in Cyclone IV Devices</b>	
Embedded Multiplier Block Overview .....	4-1
Architecture .....	4-2
Input Registers .....	4-3
Multiplier Stage .....	4-3
Output Registers .....	4-4
Operational Modes .....	4-4
18-Bit Multipliers .....	4-5
9-Bit Multipliers .....	4-6
Document Revision History .....	4-7
<b>Chapter 5. Clock Networks and PLLs in Cyclone IV Devices</b>	
Clock Networks .....	5-1
GCLK Network .....	5-2
Clock Control Block .....	5-10
GCLK Network Clock Source Generation .....	5-12
GCLK Network Power Down .....	5-16
ckena Signals .....	5-17
PLLs in Cyclone IV Devices .....	5-18
Cyclone IV PLL Hardware Overview .....	5-20
External Clock Outputs .....	5-22
Clock Feedback Modes .....	5-23
Source-Synchronous Mode .....	5-23
No Compensation Mode .....	5-24
Normal Mode .....	5-24
Zero Delay Buffer Mode .....	5-25
Deterministic Latency Compensation Mode .....	5-26
Hardware Features .....	5-26
Clock Multiplication and Division .....	5-26
Post-Scale Counter Cascading .....	5-27
Programmable Duty Cycle .....	5-27
PLL Control Signals .....	5-27
Clock Switchover .....	5-28
Automatic Clock Switchover .....	5-28
Manual Override .....	5-29

Manual Clock Switchover .....	5-30
Guidelines .....	5-30
Programmable Bandwidth .....	5-32
Phase Shift Implementation .....	5-32
PLL Cascading .....	5-33
PLL Reconfiguration .....	5-34
PLL Reconfiguration Hardware Implementation .....	5-34
Post-Scale Counters (C0 to C4) .....	5-36
Scan Chain Description .....	5-37
Charge Pump and Loop Filter .....	5-38
Bypassing a PLL Counter .....	5-39
Dynamic Phase Shifting .....	5-39
Spread-Spectrum Clocking .....	5-41
PLL Specifications .....	5-41
Document Revision History .....	5-42

## Section II. I/O Interfaces

### Chapter 6. I/O Features in Cyclone IV Devices

Cyclone IV I/O Elements .....	6-2
I/O Element Features .....	6-3
Programmable Current Strength .....	6-3
Slew Rate Control .....	6-4
Open-Drain Output .....	6-4
Bus Hold .....	6-4
Programmable Pull-Up Resistor .....	6-5
Programmable Delay .....	6-5
PCI-Clamp Diode .....	6-6
OCT Support .....	6-6
On-Chip Series Termination with Calibration .....	6-8
On-Chip Series Termination Without Calibration .....	6-10
I/O Standards .....	6-11
Termination Scheme for I/O Standards .....	6-13
Voltage-Referenced I/O Standard Termination .....	6-14
Differential I/O Standard Termination .....	6-15
I/O Banks .....	6-16
High-Speed Differential Interfaces .....	6-22
External Memory Interfacing .....	6-23
Pad Placement and DC Guidelines .....	6-23
Pad Placement .....	6-23
DC Guidelines .....	6-23
Clock Pins Functionality .....	6-23
High-Speed I/O Interface .....	6-24
High-Speed I/O Standards Support .....	6-28
High Speed Serial Interface (HSSI) Input Reference Clock Support .....	6-28
LVDS I/O Standard Support in Cyclone IV Devices .....	6-29
Designing with LVDS .....	6-30
BLVDS I/O Standard Support in Cyclone IV Devices .....	6-30
Designing with BLVDS .....	6-31
RSDS, Mini-LVDS, and PPDS I/O Standard Support in Cyclone IV Devices .....	6-32
Designing with RSDS, Mini-LVDS, and PPDS .....	6-32
LVPECL I/O Support in Cyclone IV Devices .....	6-34
Differential SSTL I/O Standard Support in Cyclone IV Devices .....	6-35

Differential HSTL I/O Standard Support in Cyclone IV Devices .....	6–35
True Differential Output Buffer Feature .....	6–35
Programmable Pre-Emphasis .....	6–35
High-Speed I/O Timing .....	6–36
Design Guidelines .....	6–37
Differential Pad Placement Guidelines .....	6–37
Board Design Considerations .....	6–38
Software Overview .....	6–38
Document Revision History .....	6–39

## Chapter 7. External Memory Interfaces in Cyclone IV Devices

Cyclone IV Devices Memory Interfaces Pin Support .....	7–2
Data and Data Clock/Strobe Pins .....	7–2
Optional Parity, DM, and Error Correction Coding Pins .....	7–11
Address and Control/Command Pins .....	7–12
Memory Clock Pins .....	7–12
Cyclone IV Devices Memory Interfaces Features .....	7–12
DDR Input Registers .....	7–12
DDR Output Registers .....	7–14
OCT with Calibration .....	7–15
PLL .....	7–15
Document Revision History .....	7–16

## Section III. System Integration

### Chapter 8. Configuration and Remote System Upgrades in Cyclone IV Devices

Configuration .....	8–1
Configuration Features .....	8–2
Configuration Data Decompression .....	8–2
Configuration Requirement .....	8–3
Power-On Reset (POR) Circuit .....	8–4
Configuration File Size .....	8–4
Configuration and JTAG Pin I/O Requirements .....	8–5
Configuration Process .....	8–6
Power Up .....	8–6
Reset .....	8–6
Configuration .....	8–6
Configuration Error .....	8–7
Initialization .....	8–7
User Mode .....	8–7
Configuration Scheme .....	8–8
AS Configuration (Serial Configuration Devices) .....	8–10
Single-Device AS Configuration .....	8–10
Multi-Device AS Configuration .....	8–13
Configuring Multiple Cyclone IV Devices with the Same Design .....	8–14
Guidelines for Connecting a Serial Configuration Device to Cyclone IV Devices for an AS Interface .....	8–18
Programming Serial Configuration Devices .....	8–19
AP Configuration (Supported Flash Memories) .....	8–21
AP Configuration Supported Flash Memories .....	8–22
Single-Device AP Configuration .....	8–23
Multi-Device AP Configuration .....	8–25
Byte-Wide Multi-Device AP Configuration .....	8–26

Word-Wide Multi-Device AP Configuration	8–26
Guidelines for Connecting Parallel Flash to Cyclone IV E Devices for an AP Interface	8–28
Configuring With Multiple Bus Masters	8–28
Estimating AP Configuration Time	8–30
Programming Parallel Flash Memories	8–31
PS Configuration	8–32
PS Configuration Using an External Host	8–33
PS Configuration Timing	8–36
PS Configuration Using a Download Cable	8–37
FPP Configuration	8–40
FPP Configuration Using an External Host	8–40
FPP Configuration Timing	8–44
JTAG Configuration	8–45
Configuring Cyclone IV Devices with Jam STAPL	8–52
Configuring Cyclone IV Devices with the JRunner Software Driver	8–52
Combining JTAG and AS Configuration Schemes	8–53
Programming Serial Configuration Devices In-System with the JTAG Interface	8–55
JTAG Instructions	8–57
Device Configuration Pins	8–62
Remote System Upgrade	8–69
Functional Description	8–69
Enabling Remote Update	8–70
Configuration Image Types	8–70
Remote System Upgrade Mode	8–71
Remote Update Mode	8–71
Dedicated Remote System Upgrade Circuitry	8–74
Remote System Upgrade Registers	8–75
Remote System Upgrade State Machine	8–78
User Watchdog Timer	8–79
Quartus II Software Support	8–80
Document Revision History	8–80

## Chapter 9. SEU Mitigation in Cyclone IV Devices

Configuration Error Detection	9–1
User Mode Error Detection	9–2
Automated SEU Detection	9–3
CRC_ERROR Pin	9–3
Error Detection Block	9–4
Error Detection Registers	9–4
Error Detection Timing	9–5
Software Support	9–6
Accessing Error Detection Block Through User Logic	9–7
Recovering from CRC Errors	9–9
Document Revision History	9–10

## Chapter 10. JTAG Boundary-Scan Testing for Cyclone IV Devices

IEEE Std. 1149.6 Boundary-Scan Register	10–2
BST Operation Control	10–3
EXTEST_PULSE	10–5
EXTEST_TRAIN	10–5
I/O Voltage Support in a JTAG Chain	10–5
Boundary-Scan Description Language Support	10–6
Document Revision History	10–7

**Chapter 11. Power Requirements for Cyclone IV Devices**

External Power Supply Requirements .....	11-1
Hot-Socketing Specifications .....	11-2
Devices Driven Before Power-Up .....	11-2
I/O Pins Remain Tri-stated During Power-Up .....	11-2
Hot-socketing Feature Implementation .....	11-3
Power-On Reset Circuitry .....	11-3
Document Revision History .....	11-4

The chapters in this document, Cyclone IV Device Handbook,, were revised on the following dates. Where chapters or groups of chapters are available separately, part numbers are listed.

- Chapter 1. Cyclone IV FPGA Device Family Overview  
Revised: *March 2016*  
Part Number: *CYIV-51001-2.0*
  
- Chapter 2. Logic Elements and Logic Array Blocks in Cyclone IV Devices  
Revised: *November 2009*  
Part Number: *CYIV-51002-1.0*
  
- Chapter 3. Memory Blocks in Cyclone IV Devices  
Revised: *November 2011*  
Part Number: *CYIV-51003-1.1*
  
- Chapter 4. Embedded Multipliers in Cyclone IV Devices  
Revised: *February 2010*  
Part Number: *CYIV-51004-1.1*
  
- Chapter 5. Clock Networks and PLLs in Cyclone IV Devices  
Revised: *October 2012*  
Part Number: *CYIV-51005-2.4*
  
- Chapter 6. I/O Features in Cyclone IV Devices  
Revised: *March 2016*  
Part Number: *CYIV-51006-2.7*
  
- Chapter 7. External Memory Interfaces in Cyclone IV Devices  
Revised: *March 2016*  
Part Number: *CYIV-51007-2.6*
  
- Chapter 8. Configuration and Remote System Upgrades in Cyclone IV Devices  
Revised: *May 2013*  
Part Number: *CYIV-51008-1.7*
  
- Chapter 9. SEU Mitigation in Cyclone IV Devices  
Revised: *May 2013*  
Part Number: *CYIV-51009-1.3*
  
- Chapter 10. JTAG Boundary-Scan Testing for Cyclone IV Devices  
Revised: *December 2013*  
Part Number: *CYIV-51010-1.3*
  
- Chapter 11. Power Requirements for Cyclone IV Devices  
Revised: *May 2013*  
Part Number: *CYIV-51011-1.3*



This chapter provides additional information about the document and Altera.

## About this Handbook

This handbook provides comprehensive information about the Altera® Cyclone® IV family of devices.

## How to Contact Altera

To locate the most up-to-date information about Altera products, refer to the following table.

Contact <sup>(1)</sup>	Contact Method	Address
Technical support	Website	<a href="http://www.altera.com/support">www.altera.com/support</a>
Technical training	Website	<a href="http://www.altera.com/training">www.altera.com/training</a>
	Email	<a href="mailto:custrain@altera.com">custrain@altera.com</a>
Product literature	Website	<a href="http://www.altera.com/literature">www.altera.com/literature</a>
Nontechnical support (general) (software licensing)	Email	<a href="mailto:nacomp@altera.com">nacomp@altera.com</a>
	Email	<a href="mailto:authorization@altera.com">authorization@altera.com</a>









**Note to Table:**

(1) You can also contact your local Altera sales office or sales representative.

## Typographic Conventions

The following table shows the typographic conventions this document uses.

Visual Cue	Meaning
<b>Bold Type with Initial Capital Letters</b>	Indicate command names, dialog box titles, dialog box options, and other GUI labels. For example, <b>Save As</b> dialog box. For GUI elements, capitalization matches the GUI.
<b>bold type</b>	Indicates directory names, project names, disk drive names, file names, file name extensions, software utility names, and GUI labels. For example, <code>\qdesigns</code> directory, <b>D:</b> drive, and <code>chiptrip.gdf</code> file.
<i>Italic Type with Initial Capital Letters</i>	Indicate document titles. For example, <i>Stratix IV Design Guidelines</i> .
<i>italic type</i>	Indicates variables. For example, $n + 1$ . Variable names are enclosed in angle brackets (< >). For example, <code>&lt;file name&gt;</code> and <code>&lt;project name&gt;.pof</code> file.
Initial Capital Letters	Indicate keyboard keys and menu names. For example, the Delete key and the Options menu.
“Subheading Title”	Quotation marks indicate references to sections in a document and titles of Quartus II Help topics. For example, “Typographic Conventions.”

Visual Cue	Meaning
Courier type	<p>Indicates signal, port, register, bit, block, and primitive names. For example, <code>data1</code>, <code>tdi</code>, and <code>input</code>. The suffix <code>n</code> denotes an active-low signal. For example, <code>resetn</code>.</p> <p>Indicates command line commands and anything that must be typed exactly as it appears. For example, <code>c:\qdesigns\tutorial\chiptrip.gdf</code>.</p> <p>Also indicates sections of an actual file, such as a Report File, references to parts of files (for example, the AHDL keyword <code>SUBDESIGN</code>), and logic function names (for example, <code>TRI</code>).</p>
	An angled arrow instructs you to press the Enter key.
1., 2., 3., and a., b., c., and so on	Numbered steps indicate a list of items when the sequence of the items is important, such as the steps listed in a procedure.
	Bullets indicate a list of items when the sequence of the items is not important.
	The hand points to information that requires special attention.
	The question mark directs you to a software help system with related information.
	The feet direct you to another document or website with related information.
	The multimedia icon directs you to a related multimedia presentation.
	A caution calls attention to a condition or possible situation that can damage or destroy the product or your work.
	A warning calls attention to a condition or possible situation that can cause you injury.
	The envelope links to the <a href="#">Email Subscription Management Center</a> page of the Altera website, where you can sign up to receive update notifications for Altera documents.

This section provides a complete overview of all features relating to the Cyclone<sup>®</sup> IV device family, which is the most architecturally advanced, high-performance, low-power FPGA in the marketplace. This section includes the following chapters:

- [Chapter 1, Cyclone IV FPGA Device Family Overview](#)
- [Chapter 2, Logic Elements and Logic Array Blocks in Cyclone IV Devices](#)
- [Chapter 3, Memory Blocks in Cyclone IV Devices](#)
- [Chapter 4, Embedded Multipliers in Cyclone IV Devices](#)
- [Chapter 5, Clock Networks and PLLs in Cyclone IV Devices](#)

### Revision History

Refer to each chapter for its own specific revision history. For information about when each chapter was updated, refer to the Chapter Revision Dates section, which appears in the complete handbook.



Altera's new Cyclone® IV FPGA device family extends the Cyclone FPGA series leadership in providing the market's lowest-cost, lowest-power FPGAs, now with a transceiver variant. Cyclone IV devices are targeted to high-volume, cost-sensitive applications, enabling system designers to meet increasing bandwidth requirements while lowering costs.

Built on an optimized low-power process, the Cyclone IV device family offers the following two variants:

- Cyclone IV E—lowest power, high functionality with the lowest cost
- Cyclone IV GX—lowest power and lowest cost FPGAs with 3.125 Gbps transceivers



Cyclone IV E devices are offered in core voltage of 1.0 V and 1.2 V.



For more information, refer to the *Power Requirements for Cyclone IV Devices* chapter.

Providing power and cost savings without sacrificing performance, along with a low-cost integrated transceiver option, Cyclone IV devices are ideal for low-cost, small-form-factor applications in the wireless, wireline, broadcast, industrial, consumer, and communications industries.

## Cyclone IV Device Family Features

The Cyclone IV device family offers the following features:

- Low-cost, low-power FPGA fabric:
  - 6K to 150K logic elements
  - Up to 6.3 Mb of embedded memory
  - Up to 360 18 × 18 multipliers for DSP processing intensive applications
  - Protocol bridging applications for under 1.5 W total power

- Cyclone IV GX devices offer up to eight high-speed transceivers that provide:
  - Data rates up to 3.125 Gbps
  - 8B/10B encoder/decoder
  - 8-bit or 10-bit physical media attachment (PMA) to physical coding sublayer (PCS) interface
  - Byte serializer/deserializer (SERDES)
  - Word aligner
  - Rate matching FIFO
  - TX bit slipper for Common Public Radio Interface (CPRI)
  - Electrical idle
  - Dynamic channel reconfiguration allowing you to change data rates and protocols on-the-fly
  - Static equalization and pre-emphasis for superior signal integrity
  - 150 mW per channel power consumption
  - Flexible clocking structure to support multiple protocols in a single transceiver block
- Cyclone IV GX devices offer dedicated hard IP for PCI Express (PIPE) (PCIe) Gen 1:
  - ×1, ×2, and ×4 lane configurations
  - End-point and root-port configurations
  - Up to 256-byte payload
  - One virtual channel
  - 2 KB retry buffer
  - 4 KB receiver (Rx) buffer
- Cyclone IV GX devices offer a wide range of protocol support:
  - PCIe (PIPE) Gen 1 ×1, ×2, and ×4 (2.5 Gbps)
  - Gigabit Ethernet (1.25 Gbps)
  - CPRI (up to 3.072 Gbps)
  - XAUI (3.125 Gbps)
  - Triple rate serial digital interface (SDI) (up to 2.97 Gbps)
  - Serial RapidIO (3.125 Gbps)
  - Basic mode (up to 3.125 Gbps)
  - V-by-One (up to 3.0 Gbps)
  - DisplayPort (2.7 Gbps)
  - Serial Advanced Technology Attachment (SATA) (up to 3.0 Gbps)
  - OBSAI (up to 3.072 Gbps)

- Up to 532 user I/Os
  - LVDS interfaces up to 840 Mbps transmitter (Tx), 875 Mbps Rx
  - Support for DDR2 SDRAM interfaces up to 200 MHz
  - Support for QDR II SRAM and DDR SDRAM up to 167 MHz
- Up to eight phase-locked loops (PLLs) per device
- Offered in commercial and industrial temperature grades

## Device Resources

Table 1-1 lists Cyclone IV E device resources.

**Table 1-1. Resources for the Cyclone IV E Device Family**

Resources	EP4CE6	EP4CE10	EP4CE15	EP4CE22	EP4CE30	EP4CE40	EP4CE55	EP4CE75	EP4CE115
Logic elements (LEs)	6,272	10,320	15,408	22,320	28,848	39,600	55,856	75,408	114,480
Embedded memory (Kbits)	270	414	504	594	594	1,134	2,340	2,745	3,888
Embedded 18 × 18 multipliers	15	23	56	66	66	116	154	200	266
General-purpose PLLs	2	2	4	4	4	4	4	4	4
Global Clock Networks	10	10	20	20	20	20	20	20	20
User I/O Banks	8	8	8	8	8	8	8	8	8
Maximum user I/O <sup>(1)</sup>	179	179	343	153	532	532	374	426	528

**Note to Table 1-1:**

(1) The user I/Os count from pin-out files includes all general purpose I/O, dedicated clock pins, and dual purpose configuration pins. Transceiver pins and dedicated configuration pins are not included in the pin count.

Table 1-2 lists Cyclone IV GX device resources.

**Table 1-2. Resources for the Cyclone IV GX Device Family**

Resources	EP4CGX15	EP4CGX22	EP4CGX30 <sup>(1)</sup>	EP4CGX30 <sup>(2)</sup>	EP4CGX50 <sup>(3)</sup>	EP4CGX75 <sup>(3)</sup>	EP4CGX110 <sup>(3)</sup>	EP4CGX150 <sup>(3)</sup>
Logic elements (LEs)	14,400	21,280	29,440	29,440	49,888	73,920	109,424	149,760
Embedded memory (Kbits)	540	756	1,080	1,080	2,502	4,158	5,490	6,480
Embedded 18 × 18 multipliers	0	40	80	80	140	198	280	360
General purpose PLLs	1	2	2	4 <sup>(4)</sup>	4 <sup>(4)</sup>	4 <sup>(4)</sup>	4 <sup>(4)</sup>	4 <sup>(4)</sup>
Multipurpose PLLs	2 <sup>(5)</sup>	2 <sup>(5)</sup>	2 <sup>(5)</sup>	2 <sup>(5)</sup>	4 <sup>(5)</sup>	4 <sup>(5)</sup>	4 <sup>(5)</sup>	4 <sup>(5)</sup>
Global clock networks	20	20	20	30	30	30	30	30
High-speed transceivers <sup>(6)</sup>	2	4	4	4	8	8	8	8
Transceiver maximum data rate (Gbps)	2.5	2.5	2.5	3.125	3.125	3.125	3.125	3.125
PCIe (PIPE) hard IP blocks	1	1	1	1	1	1	1	1
User I/O banks	9 <sup>(7)</sup>	9 <sup>(7)</sup>	9 <sup>(7)</sup>	11 <sup>(8)</sup>	11 <sup>(8)</sup>	11 <sup>(8)</sup>	11 <sup>(8)</sup>	11 <sup>(8)</sup>
Maximum user I/O <sup>(9)</sup>	72	150	150	290	310	310	475	475

**Notes to Table 1-2:**

- (1) Applicable for the F169 and F324 packages.
- (2) Applicable for the F484 package.
- (3) Only two multipurpose PLLs for F484 package.
- (4) Two of the general purpose PLLs are able to support transceiver clocking. For more information, refer to the *Clock Networks and PLLs in Cyclone IV Devices* chapter.
- (5) You can use the multipurpose PLLs for general purpose clocking when they are not used to clock the transceivers. For more information, refer to the *Clock Networks and PLLs in Cyclone IV Devices* chapter.
- (6) If PCIe ×1, you can use the remaining transceivers in a quad for other protocols at the same or different data rates.
- (7) Including one configuration I/O bank and two dedicated clock input I/O banks for HSSI reference clock input.
- (8) Including one configuration I/O bank and four dedicated clock input I/O banks for HSSI reference clock input.
- (9) The user I/Os count from pin-out files includes all general purpose I/O, dedicated clock pins, and dual purpose configuration pins. Transceiver pins and dedicated configuration pins are not included in the pin count.

# Package Matrix

Table 1–3 lists Cyclone IV E device package offerings.

Table 1–3. Package Offerings for the Cyclone IV E Device Family <sup>(1)</sup>, <sup>(2)</sup>

Package	E144	M164	M256	U256	F256	F324	U484	F	
Size (mm)	22 x 22	8 x 8	9 x 9	14 x 14	17 x 17	19 x 19	19 x 19	23	
Pitch (mm)	0.5	0.5	0.5	0.8	1.0	1.0	0.8	1	
Device	User I/O	LVDS <sup>(3)</sup>	User I/O	LVDS <sup>(3)</sup>	User I/O	LVDS <sup>(3)</sup>	User I/O	LVDS <sup>(3)</sup>	User I/O
EP4CE6	91	21	—	66	179	66	—	—	—
EP4CE10	91	21	—	66	179	66	—	—	—
EP4CE15	81	18	89	53	165	53	—	—	343
EP4CE22	79	17	—	52	153	52	—	—	—
EP4CE30	—	—	—	—	—	—	193	68	328
EP4CE40	—	—	—	—	—	—	193	68	328
EP4CE55	—	—	—	—	—	—	—	—	324
EP4CE75	—	—	—	—	—	—	—	—	292
EP4CE115	—	—	—	—	—	—	—	—	280

### Notes to Table 1–3:

- (1) The E144 package has an exposed pad at the bottom of the package. This exposed pad is a ground pad that must be connected to the ground plane of your PCB. Use connectivity and not for thermal purposes.
- (2) Use the Pin Migration View window in Pin Planner of the Quartus II software to verify the pin migration compatibility when you perform device migration. For more information, refer to the *Management* chapter in volume 2 of the *Quartus II Handbook*.
- (3) This includes both dedicated and emulated LVDS pairs. For more information, refer to the *I/O Features in Cyclone IV Devices* chapter.

Table 1-4 lists Cyclone IV GX device package offerings, including I/O and transceiver counts.

**Table 1-4. Package Offerings for the Cyclone IV GX Device Family <sup>(1)</sup>**

Package	F169			F324			F484			F672		
Size (mm)	14 x 14			19 x 19			23 x 23			27 x 27		
Pitch (mm)	1.0			1.0			1.0			1.0		
Device	User I/O	LVDS <sup>(2)</sup>	XCVRS	User I/O	LVDS <sup>(2)</sup>	XCVRS	User I/O	LVDS <sup>(2)</sup>	XCVRS	User I/O	LVDS <sup>(2)</sup>	XCVRS
EP4CGX15	72	25	2	—	—	—	—	—	—	—	—	—
EP4CGX22	72	25	2	150	64	4	—	—	—	—	—	—
EP4CGX30	72	25	2	150	64	4	290	130	4	—	—	—
EP4CGX50	—	—	—	—	—	—	290	130	4	310	140	8
EP4CGX75	—	—	—	—	—	—	290	130	4	310	140	8
EP4CGX110	—	—	—	—	—	—	270	120	4	393	181	8
EP4CGX150	—	—	—	—	—	—	270	120	4	393	181	8

**Note to Table 1-4:**

- (1) Use the Pin Migration View window in Pin Planner of the Quartus II software to verify the pin migration compatibility when you perform a pin migration. For more information, refer to the *I/O Management* chapter in volume 2 of the *Quartus II Handbook*.
- (2) This includes both dedicated and emulated LVDS pairs. For more information, refer to the *I/O Features in Cyclone IV Devices* chapter.

## Cyclone IV Device Family Speed Grades

Table 1-5 lists the Cyclone IV GX devices speed grades.

**Table 1-5. Speed Grades for the Cyclone IV GX Device Family**

Device	F169	F324	F484	F672	F896
EP4CGX15	C6, C7, C8, I7	—	—	—	—
EP4CGX22	C6, C7, C8, I7	C6, C7, C8, I7	—	—	—
EP4CGX30	C6, C7, C8, I7	C6, C7, C8, I7	C6, C7, C8, I7	—	—
EP4CGX50	—	—	C6, C7, C8, I7	C6, C7, C8, I7	—
EP4CGX75	—	—	C6, C7, C8, I7	C6, C7, C8, I7	—
EP4CGX110	—	—	C7, C8, I7	C7, C8, I7	C7, C8, I7
EP4CGX150	—	—	C7, C8, I7	C7, C8, I7	C7, C8, I7

Table 1-6 lists the Cyclone IV E devices speed grades.

**Table 1-6. Speed Grades for the Cyclone IV E Device Family <sup>(1)</sup>, <sup>(2)</sup>**

Device	E144	M164	M256	U256	F256	F324	U484	F484	F780
EP4CE6	C8L, C9L, I8L C6, C7, C8, I7, A7	—	—	I7N	C8L, C9L, I8L C6, C7, C8, I7, A7	—	—	—	—
EP4CE10	C8L, C9L, I8L C6, C7, C8, I7, A7	—	—	I7N	C8L, C9L, I8L C6, C7, C8, I7, A7	—	—	—	—
EP4CE15	C8L, C9L, I8L C6, C7, C8, I7	I7N	C7N, I7N	I7N	C8L, C9L, I8L C6, C7, C8, I7, A7	—	—	C8L, C9L, I8L C6, C7, C8, I7, A7	—
EP4CE22	C8L, C9L, I8L C6, C7, C8, I7, A7	—	—	I7N	C8L, C9L, I8L C6, C7, C8, I7, A7	—	—	—	—
EP4CE30	—	—	—	—	—	A7N	—	C8L, C9L, I8L C6, C7, C8, I7, A7	C8L, C9L, I8L C6, C7, C8, I7
EP4CE40	—	—	—	—	—	A7N	I7N	C8L, C9L, I8L C6, C7, C8, I7, A7	C8L, C9L, I8L C6, C7, C8, I7
EP4CE55	—	—	—	—	—	—	I7N	C8L, C9L, I8L C6, C7, C8, I7	C8L, C9L, I8L C6, C7, C8, I7
EP4CE75	—	—	—	—	—	—	I7N	C8L, C9L, I8L C6, C7, C8, I7	C8L, C9L, I8L C6, C7, C8, I7
EP4CE115	—	—	—	—	—	—	—	C8L, C9L, I8L C7, C8, I7	C8L, C9L, I8L C7, C8, I7

**Notes to Table 1-6:**

- (1) C8L, C9L, and I8L speed grades are applicable for the 1.0-V core voltage.
- (2) C6, C7, C8, I7, and A7 speed grades are applicable for the 1.2-V core voltage.

## Cyclone IV Device Family Architecture

This section describes Cyclone IV device architecture and contains the following topics:

- “FPGA Core Fabric”
- “I/O Features”
- “Clock Management”
- “External Memory Interfaces”
- “Configuration”
- “High-Speed Transceivers (Cyclone IV GX Devices Only)”
- “Hard IP for PCI Express (Cyclone IV GX Devices Only)”

### FPGA Core Fabric

Cyclone IV devices leverage the same core fabric as the very successful Cyclone series devices. The fabric consists of LEs, made of 4-input look up tables (LUTs), memory blocks, and multipliers.

Each Cyclone IV device M9K memory block provides 9 Kbits of embedded SRAM memory. You can configure the M9K blocks as single port, simple dual port, or true dual port RAM, as well as FIFO buffers or ROM. They can also be configured to implement any of the data widths in [Table 1–7](#).

**Table 1–7. M9K Block Data Widths for Cyclone IV Device Family**

Mode	Data Width Configurations
Single port or simple dual port	×1, ×2, ×4, ×8/9, ×16/18, and ×32/36
True dual port	×1, ×2, ×4, ×8/9, and ×16/18

The multiplier architecture in Cyclone IV devices is the same as in the existing Cyclone series devices. The embedded multiplier blocks can implement an  $18 \times 18$  or two  $9 \times 9$  multipliers in a single block. Altera offers a complete suite of DSP IP including finite impulse response (FIR), fast Fourier transform (FFT), and numerically controlled oscillator (NCO) functions for use with the multiplier blocks. The Quartus® II design software’s DSP Builder tool integrates MathWorks Simulink and MATLAB design environments for a streamlined DSP design flow.



For more information, refer to the *Logic Elements and Logic Array Blocks in Cyclone IV Devices*, *Memory Blocks in Cyclone IV Devices*, and *Embedded Multipliers in Cyclone IV Devices* chapters.

## I/O Features

Cyclone IV device I/O supports programmable bus hold, programmable pull-up resistors, programmable delay, programmable drive strength, programmable slew-rate control to optimize signal integrity, and hot socketing. Cyclone IV devices support calibrated on-chip series termination (Rs OCT) or driver impedance matching (Rs) for single-ended I/O standards. In Cyclone IV GX devices, the high-speed transceiver I/Os are located on the left side of the device. The top, bottom, and right sides can implement general-purpose user I/Os.

Table 1-8 lists the I/O standards that Cyclone IV devices support.

**Table 1-8. I/O Standards Support for the Cyclone IV Device Family**

Type	I/O Standard
Single-Ended I/O	LVTTTL, LVCMOS, SSTL, HSTL, PCI, and PCI-X
Differential I/O	SSTL, HSTL, LVPECL, BLVDS, LVDS, mini-LVDS, RSDS, and PPDS

The LVDS SERDES is implemented in the core of the device using logic elements.

 For more information, refer to the *I/O Features in Cyclone IV Devices* chapter.

## Clock Management

Cyclone IV devices include up to 30 global clock (GCLK) networks and up to eight PLLs with five outputs per PLL to provide robust clock management and synthesis. You can dynamically reconfigure Cyclone IV device PLLs in user mode to change the clock frequency or phase.

Cyclone IV GX devices support two types of PLLs: multipurpose PLLs and general-purpose PLLs:

- Use multipurpose PLLs for clocking the transceiver blocks. You can also use them for general-purpose clocking when they are not used for transceiver clocking.
- Use general purpose PLLs for general-purpose applications in the fabric and periphery, such as external memory interfaces. Some of the general purpose PLLs can support transceiver clocking.

 For more information, refer to the *Clock Networks and PLLs in Cyclone IV Devices* chapter.

## External Memory Interfaces

Cyclone IV devices support SDR, DDR, DDR2 SDRAM, and QDR II SRAM interfaces on the top, bottom, and right sides of the device. Cyclone IV E devices also support these interfaces on the left side of the device. Interfaces may span two or more sides of the device to allow more flexible board design. The Altera® DDR SDRAM memory interface solution consists of a PHY interface and a memory controller. Altera supplies the PHY IP and you can use it in conjunction with your own custom memory controller or an Altera-provided memory controller. Cyclone IV devices support the use of error correction coding (ECC) bits on DDR and DDR2 SDRAM interfaces.

 For more information, refer to the *External Memory Interfaces in Cyclone IV Devices* chapter.

## Configuration

Cyclone IV devices use SRAM cells to store configuration data. Configuration data is downloaded to the Cyclone IV device each time the device powers up. Low-cost configuration options include the Altera EPCS family serial flash devices and commodity parallel flash configuration options. These options provide the flexibility for general-purpose applications and the ability to meet specific configuration and wake-up time requirements of the applications.

Table 1-9 lists which configuration schemes are supported by Cyclone IV devices.

**Table 1-9. Configuration Schemes for Cyclone IV Device Family**

Devices	Supported Configuration Scheme
Cyclone IV GX	AS, PS, JTAG, and FPP <sup>(1)</sup>
Cyclone IV E	AS, AP, PS, FPP, and JTAG

**Note to Table 1-9:**

(1) The FPP configuration scheme is only supported by the EP4CGX30F484 and EP4CGX50/75/110/150 devices.

IEEE 1149.6 (AC JTAG) is supported on all transceiver I/O pins. All other pins support IEEE 1149.1 (JTAG) for boundary scan testing.

 For more information, refer to the *JTAG Boundary-Scan Testing for Cyclone IV Devices* chapter.

For Cyclone IV GX devices to meet the PCIe 100 ms wake-up time requirement, you must use passive serial (PS) configuration mode for the EP4CGX15/22/30 devices and use fast passive parallel (FPP) configuration mode for the EP4CGX30F484 and EP4CGX50/75/110/150 devices.

 For more information, refer to the *Configuration and Remote System Upgrades in Cyclone IV Devices* chapter.

The cyclical redundancy check (CRC) error detection feature during user mode is supported in all Cyclone IV GX devices. For Cyclone IV E devices, this feature is only supported for the devices with the core voltage of 1.2 V.

 For more information about CRC error detection, refer to the *SEU Mitigation in Cyclone IV Devices* chapter.

## High-Speed Transceivers (Cyclone IV GX Devices Only)

Cyclone IV GX devices contain up to eight full duplex high-speed transceivers that can operate independently. These blocks support multiple industry-standard communication protocols, as well as Basic mode, which you can use to implement your own proprietary protocols. Each transceiver channel has its own pre-emphasis and equalization circuitry, which you can set at compile time to optimize signal integrity and reduce bit error rates. Transceiver blocks also support dynamic reconfiguration, allowing you to change data rates and protocols on-the-fly.

Figure 1-1 shows the structure of the Cyclone IV GX transceiver.

**Figure 1-1. Transceiver Channel for the Cyclone IV GX Device**

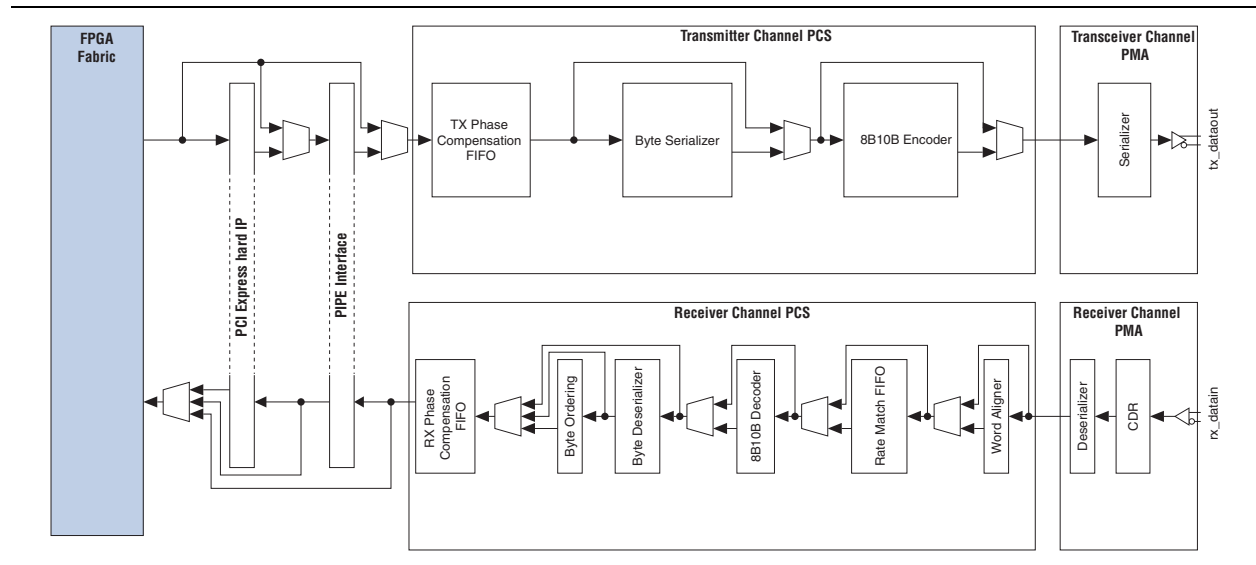

For more information, refer to the *Cyclone IV Transceivers Architecture* chapter.

## Hard IP for PCI Express (Cyclone IV GX Devices Only)

Cyclone IV GX devices incorporate a single hard IP block for  $\times 1$ ,  $\times 2$ , or  $\times 4$  PCIe (PIPE) in each device. This hard IP block is a complete PCIe (PIPE) protocol solution that implements the PHY-MAC layer, Data Link Layer, and Transaction Layer functionality. The hard IP for the PCIe (PIPE) block supports root-port and end-point configurations. This pre-verified hard IP block reduces risk, design time, timing closure, and verification. You can configure the block with the Quartus II software's PCI Express Compiler, which guides you through the process step by step.

For more information, refer to the *PCI Express Compiler User Guide*.

## Reference and Ordering Information

Figure 1-2 shows the ordering codes for Cyclone IV GX devices.

**Figure 1-2. Packaging Ordering Information for the Cyclone IV GX Device**

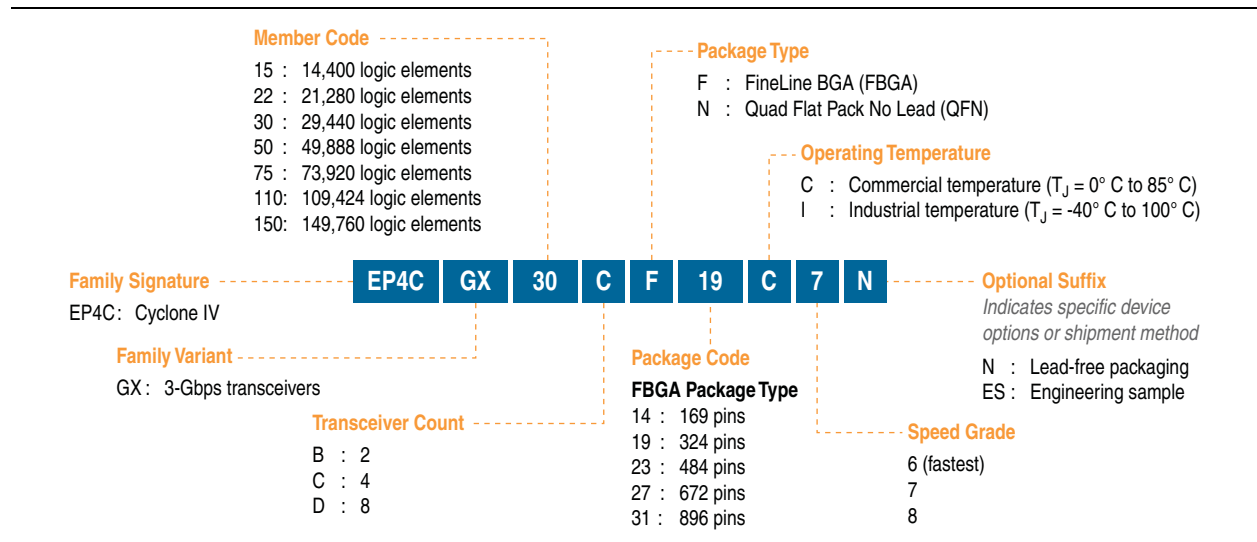
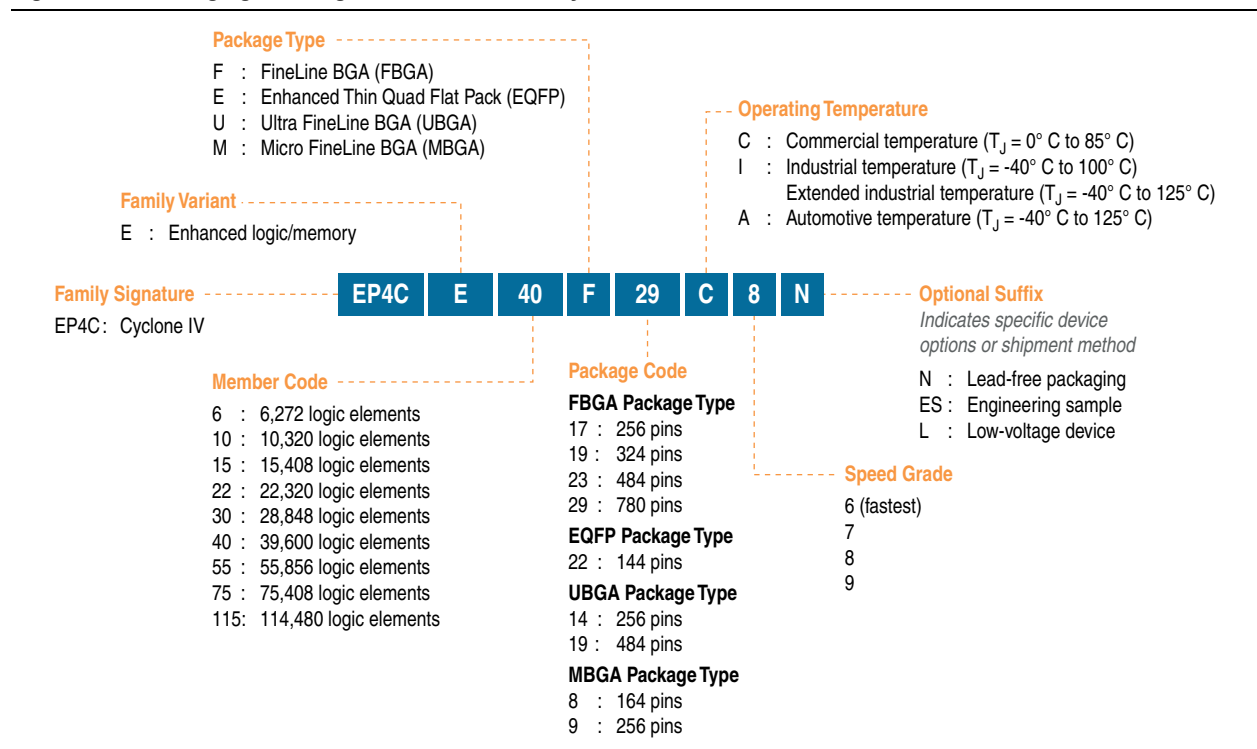

Figure 1-3 shows the ordering codes for Cyclone IV E devices.

**Figure 1-3. Packaging Ordering Information for the Cyclone IV E Device**



## Document Revision History

Table 1-10 lists the revision history for this chapter.

**Table 1-10. Document Revision History**

Date	Version	Changes
March 2016	2.0	<ul style="list-style-type: none"> <li>■ Updated Table 1-4 and Table 1-5 to remove support for the N148 package.</li> <li>■ Updated Figure 1-2 to remove support for the N148 package.</li> </ul>
April 2014	1.9	Updated “Packaging Ordering Information for the Cyclone IV E Device”.
May 2013	1.8	Updated Table 1-3, Table 1-6 and Figure 1-3 to add new device options and packages.
February 2013	1.7	Updated Table 1-3, Table 1-6 and Figure 1-3 to add new device options and packages.
October 2012	1.6	Updated Table 1-3 and Table 1-4.
November 2011	1.5	<ul style="list-style-type: none"> <li>■ Updated “Cyclone IV Device Family Features” section.</li> <li>■ Updated Figure 1-2 and Figure 1-3.</li> </ul>
December 2010	1.4	<ul style="list-style-type: none"> <li>■ Updated for the Quartus II software version 10.1 release.</li> <li>■ Added Cyclone IV E new device package information.</li> <li>■ Updated Table 1-1, Table 1-2, Table 1-3, Table 1-5, and Table 1-6.</li> <li>■ Updated Figure 1-3.</li> <li>■ Minor text edits.</li> </ul>
July 2010	1.3	Updated Table 1-2 to include F484 package information.
March 2010	1.2	<ul style="list-style-type: none"> <li>■ Updated Table 1-3 and Table 1-6.</li> <li>■ Updated Figure 1-3.</li> <li>■ Minor text edits.</li> </ul>
February 2010	1.1	<ul style="list-style-type: none"> <li>■ Added Cyclone IV E devices in Table 1-1, Table 1-3, and Table 1-6 for the Quartus II software version 9.1 SP1 release.</li> <li>■ Added the “Cyclone IV Device Family Speed Grades” and “Configuration” sections.</li> <li>■ Added Figure 1-3 to include Cyclone IV E Device Packaging Ordering Information.</li> <li>■ Updated Table 1-2, Table 1-4, and Table 1-5 for Cyclone IV GX devices.</li> <li>■ Minor text edits.</li> </ul>
November 2009	1.0	Initial release.



This chapter contains feature definitions for logic elements (LEs) and logic array blocks (LABs). Details are provided on how LEs work, how LABs contain groups of LEs, and how LABs interface with the other blocks in Cyclone® IV devices.

### Logic Elements

Logic elements (LEs) are the smallest units of logic in the Cyclone IV device architecture. LEs are compact and provide advanced features with efficient logic usage. Each LE has the following features:

- A four-input look-up table (LUT), which can implement any function of four variables
- A programmable register
- A carry chain connection
- A register chain connection
- The ability to drive the following interconnects:
  - Local
  - Row
  - Column
  - Register chain
  - Direct link
- Register packing support
- Register feedback support

Figure 2-1 shows the LEs for Cyclone IV devices.

**Figure 2-1. Cyclone IV Device LEs**

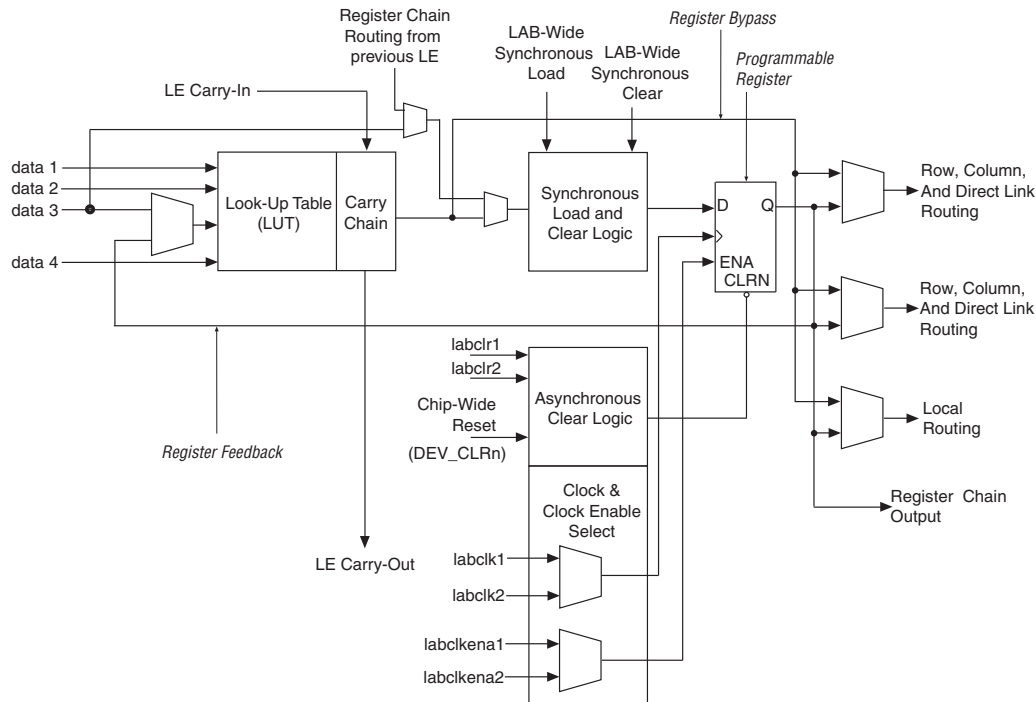

## LE Features

You can configure the programmable register of each LE for D, T, JK, or SR flipflop operation. Each register has data, clock, clock enable, and clear inputs. Signals that use the global clock network, general-purpose I/O pins, or any internal logic can drive the clock and clear control signals of the register. Either general-purpose I/O pins or the internal logic can drive the clock enable. For combinational functions, the LUT output bypasses the register and drives directly to the LE outputs.

Each LE has three outputs that drive the local, row, and column routing resources. The LUT or register output independently drives these three outputs. Two LE outputs drive the column or row and direct link routing connections, while one LE drives the local interconnect resources. This allows the LUT to drive one output while the register drives another output. This feature, called register packing, improves device utilization because the device can use the register and the LUT for unrelated functions. The LAB-wide synchronous load control signal is not available when using register packing. For more information about the synchronous load control signal, refer to “LAB Control Signals” on page 2-6.

The register feedback mode allows the register output to feed back into the LUT of the same LE to ensure that the register is packed with its own fan-out LUT, providing another mechanism for improved fitting. The LE can also drive out registered and unregistered versions of the LUT output.

In addition to the three general routing outputs, LEs in an LAB have register chain outputs, which allows registers in the same LAB to cascade together. The register chain output allows the LUTs to be used for combinational functions and the registers to be used for an unrelated shift register implementation. These resources speed up connections between LABs while saving local interconnect resources.

## LE Operating Modes

Cyclone IV LEs operate in the following modes:

- Normal mode
- Arithmetic mode

The Quartus® II software automatically chooses the appropriate mode for common functions, such as counters, adders, subtractors, and arithmetic functions, in conjunction with parameterized functions such as the library of parameterized modules (LPM) functions. You can also create special-purpose functions that specify which LE operating mode to use for optimal performance, if required.

### Normal Mode

Normal mode is suitable for general logic applications and combinational functions. In normal mode, four data inputs from the LAB local interconnect are inputs to a four-input LUT (Figure 2-2). The Quartus II Compiler automatically selects the carry-in (cin) or the data3 signal as one of the inputs to the LUT. LEs in normal mode support packed registers and register feedback.

Figure 2-2 shows LEs in normal mode.

**Figure 2-2. Cyclone IV Device LEs in Normal Mode**

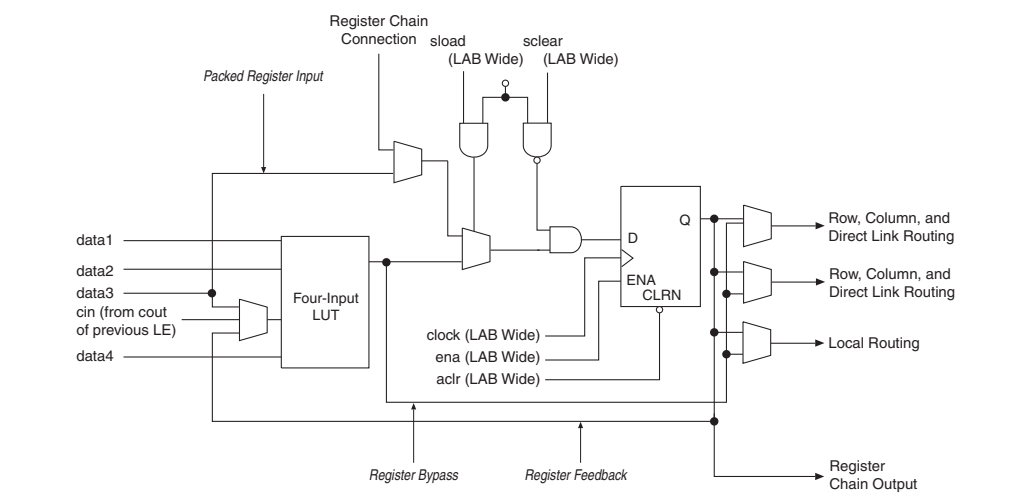

## Arithmetic Mode

Arithmetic mode is ideal for implementing adders, counters, accumulators, and comparators. An LE in arithmetic mode implements a 2-bit full adder and basic carry chain (Figure 2-3). LEs in arithmetic mode can drive out registered and unregistered versions of the LUT output. Register feedback and register packing are supported when LEs are used in arithmetic mode.

Figure 2-3 shows LEs in arithmetic mode.

**Figure 2-3. Cyclone IV Device LEs in Arithmetic Mode**

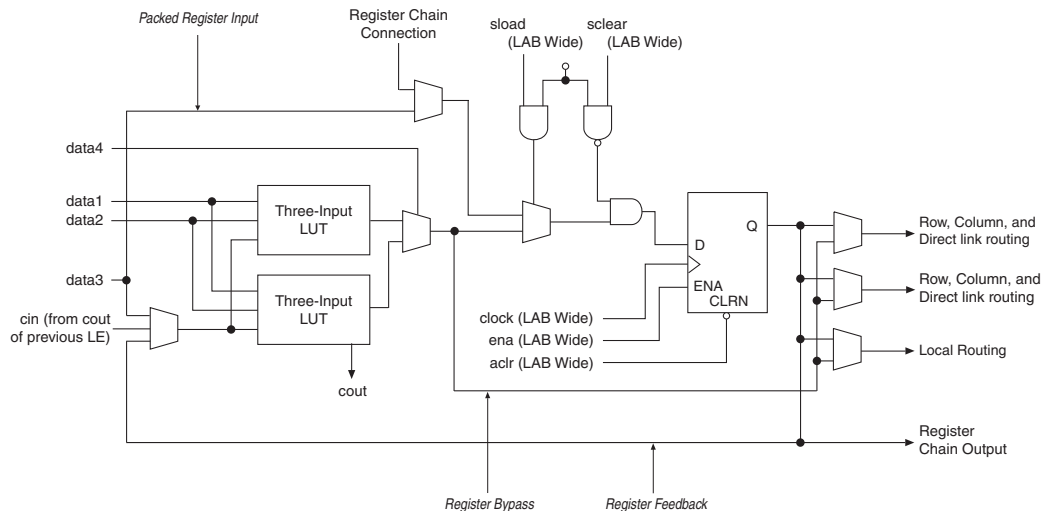

The Quartus II Compiler automatically creates carry chain logic during design processing. You can also manually create the carry chain logic during design entry. Parameterized functions, such as LPM functions, automatically take advantage of carry chains for the appropriate functions.

The Quartus II Compiler creates carry chains longer than 16 LEs by automatically linking LABs in the same column. For enhanced fitting, a long carry chain runs vertically, which allows fast horizontal connections to M9K memory blocks or embedded multipliers through direct link interconnects. For example, if a design has a long carry chain in an LAB column next to a column of M9K memory blocks, any LE output can feed an adjacent M9K memory block through the direct link interconnect. If the carry chains run horizontally, any LAB which is not next to the column of M9K memory blocks uses other row or column interconnects to drive a M9K memory block. A carry chain continues as far as a full column.

## Logic Array Blocks

Logic array blocks (LABs) contain groups of LEs.

### Topology

Each LAB consists of the following features:

- 16 LEs
- LAB control signals
- LE carry chains
- Register chains
- Local interconnect

The local interconnect transfers signals between LEs in the same LAB. Register chain connections transfer the output of one LE register to the adjacent LE register in an LAB. The Quartus II Compiler places associated logic in an LAB or adjacent LABs, allowing the use of local and register chain connections for performance and area efficiency.

Figure 2-4 shows the LAB structure for Cyclone IV devices.

**Figure 2-4. Cyclone IV Device LAB Structure**

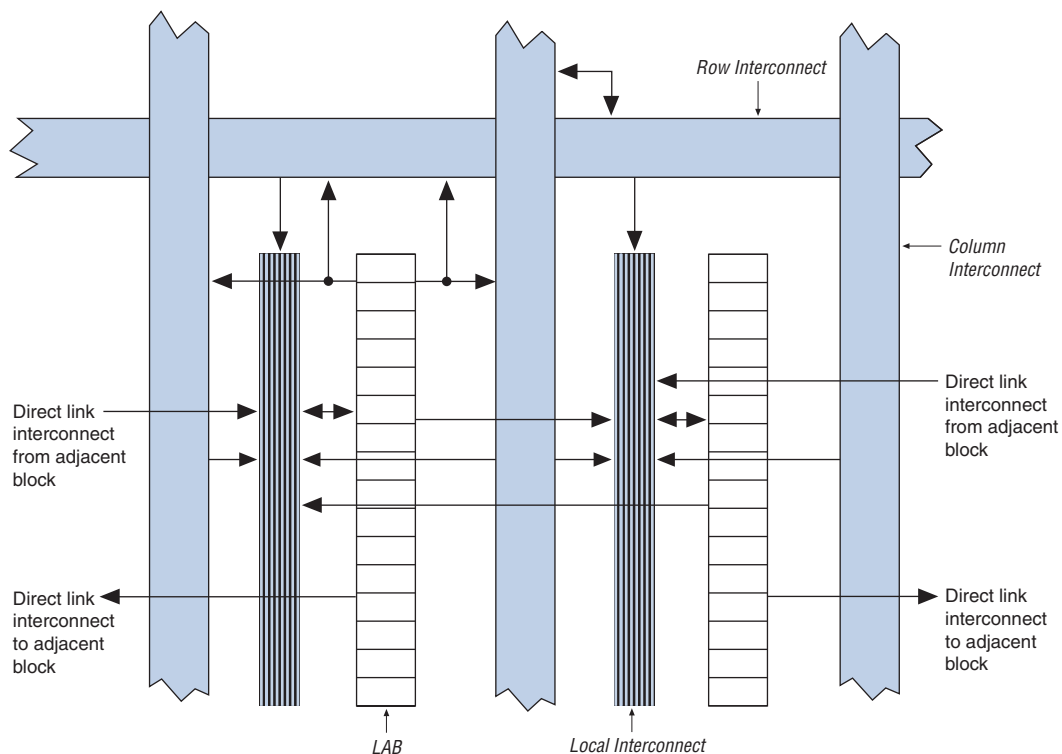

## LAB Interconnects

The LAB local interconnect is driven by column and row interconnects and LE outputs in the same LAB. Neighboring LABs, phase-locked loops (PLLs), M9K RAM blocks, and embedded multipliers from the left and right can also drive the local interconnect of a LAB through the direct link connection. The direct link connection feature minimizes the use of row and column interconnects, providing higher performance and flexibility. Each LE can drive up to 48 LEs through fast local and direct link interconnects.

Figure 2-5 shows the direct link connection.

**Figure 2-5. Cyclone IV Device Direct Link Connection**

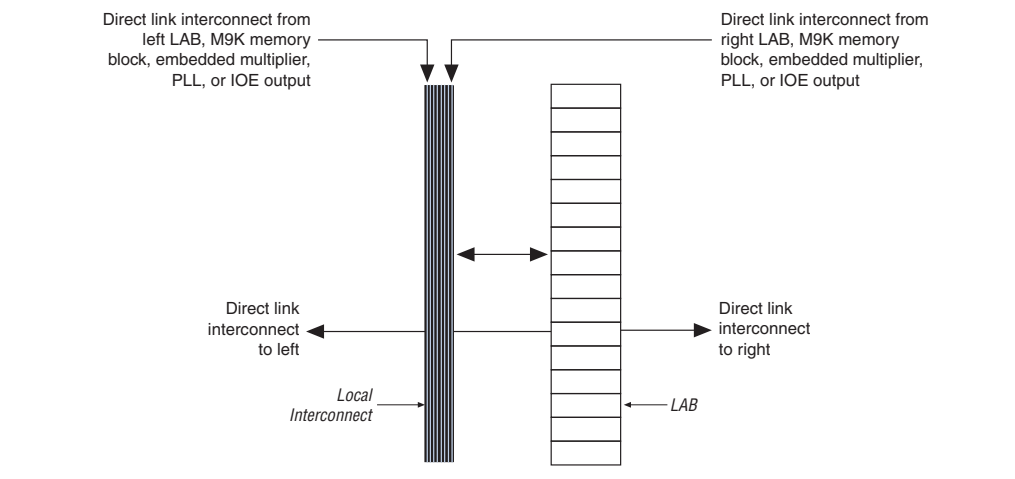

## LAB Control Signals

Each LAB contains dedicated logic for driving control signals to its LEs. The control signals include:

- Two clocks
- Two clock enables
- Two asynchronous clears
- One synchronous clear
- One synchronous load

You can use up to eight control signals at a time. Register packing and synchronous load cannot be used simultaneously.

Each LAB can have up to four non-global control signals. You can use additional LAB control signals as long as they are global signals.

Synchronous clear and load signals are useful for implementing counters and other functions. The synchronous clear and synchronous load signals are LAB-wide signals that affect all registers in the LAB.

Each LAB can use two clocks and two clock enable signals. The clock and clock enable signals of each LAB are linked. For example, any LE in a particular LAB using the `labclk1` signal also uses the `labclkena1`. If the LAB uses both the rising and falling edges of a clock, it also uses both LAB-wide clock signals. Deasserting the clock enable signal turns off the LAB-wide clock.

The LAB row clocks [5..0] and LAB local interconnect generate the LAB-wide control signals. The MultiTrack interconnect inherent low skew allows clock and control signal distribution in addition to data distribution.

Figure 2-6 shows the LAB control signal generation circuit.

**Figure 2-6. Cyclone IV Device LAB-Wide Control Signals**

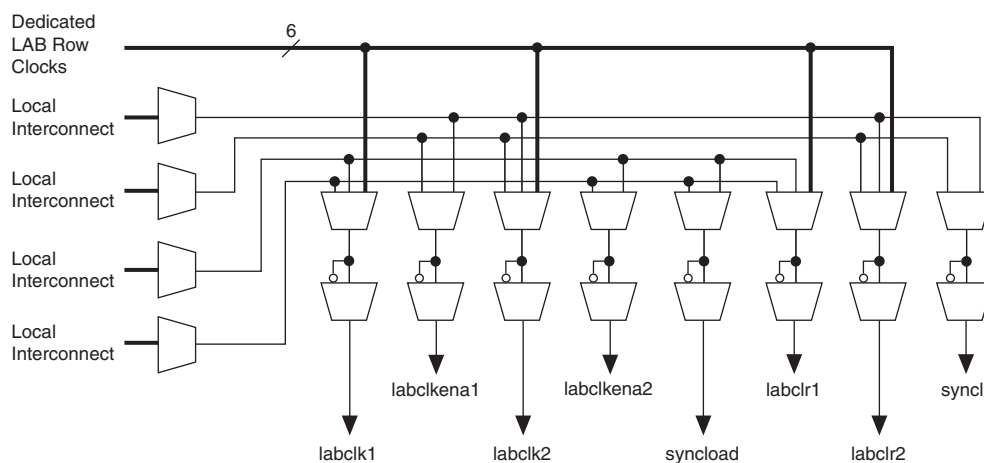

LAB-wide signals control the logic for the clear signal of the register. The LE directly supports an asynchronous clear function. Each LAB supports up to two asynchronous clear signals (`labclr1` and `labclr2`).

A LAB-wide asynchronous load signal to control the logic for the preset signal of the register is not available. The register preset is achieved with a NOT gate push-back technique. Cyclone IV devices only support either a preset or asynchronous clear signal.

In addition to the clear port, Cyclone IV devices provide a chip-wide reset pin (`DEV_CLRn`) that resets all registers in the device. An option set before compilation in the Quartus II software controls this pin. This chip-wide reset overrides all other control signals.

## Document Revision History

Table 2-1 shows the revision history for this chapter.

**Table 2-1. Document Revision History**

Date	Version	Changes
November 2009	1.0	Initial release.



Cyclone® IV devices feature embedded memory structures to address the on-chip memory needs of Altera® Cyclone IV device designs. The embedded memory structure consists of columns of M9K memory blocks that you can configure to provide various memory functions, such as RAM, shift registers, ROM, and FIFO buffers.

This chapter contains the following sections:

- “Memory Modes” on page 3–7
- “Clocking Modes” on page 3–14
- “Design Considerations” on page 3–15

### Overview

M9K blocks support the following features:

- 8,192 memory bits per block (9,216 bits per block including parity)
- Independent read-enable (*rden*) and write-enable (*wren*) signals for each port
- Packed mode in which the M9K memory block is split into two 4.5 K single-port RAMs
- Variable port configurations
- Single-port and simple dual-port modes support for all port widths
- True dual-port (one read and one write, two reads, or two writes) operation
- Byte enables for data input masking during writes
- Two clock-enable control signals for each port (port A and port B)
- Initialization file to pre-load memory content in RAM and ROM modes

Table 3-1 lists the features supported by the M9K memory.

**Table 3-1. Summary of M9K Memory Features**

Feature	M9K Blocks
Configurations (depth × width)	8192 × 1
	4096 × 2
	2048 × 4
	1024 × 8
	1024 × 9
	512 × 16
	512 × 18
	256 × 32
	256 × 36
Parity bits	✓
Byte enable	✓
Packed mode	✓
Address clock enable	✓
Single-port mode	✓
Simple dual-port mode	✓
True dual-port mode	✓
Embedded shift register mode <sup>(1)</sup>	✓
ROM mode	✓
FIFO buffer <sup>(1)</sup>	✓
Simple dual-port mixed width support	✓
True dual-port mixed width support <sup>(2)</sup>	✓
Memory initialization file (.mif)	✓
Mixed-clock mode	✓
Power-up condition	Outputs cleared
Register asynchronous clears	Read address registers and output registers only
Latch asynchronous clears	Output latches only
Write or read operation triggering	Write and read: Rising clock edges
Same-port read-during-write	Outputs set to <b>Old Data</b> or <b>New Data</b>
Mixed-port read-during-write	Outputs set to <b>Old Data</b> or <b>Don't Care</b>

**Notes to Table 3-1:**

- (1) FIFO buffers and embedded shift registers that require external logic elements (LEs) for implementing control logic.
- (2) Width modes of ×32 and ×36 are not available.



For information about the number of M9K memory blocks for Cyclone IV devices, refer to the *Cyclone IV Device Family Overview* chapter in volume 1 of the *Cyclone IV Device Handbook*.

## Control Signals

The clock-enable control signal controls the clock entering the input and output registers and the entire M9K memory block. This signal disables the clock so that the M9K memory block does not see any clock edges and does not perform any operations.

The `rden` and `wren` control signals control the read and write operations for each port of M9K memory blocks. You can disable the `rden` or `wren` signals independently to save power whenever the operation is not required.

## Parity Bit Support

Parity checking for error detection is possible with the parity bit along with internal logic resources. Cyclone IV devices M9K memory blocks support a parity bit for each storage byte. You can use this bit as either a parity bit or as an additional data bit. No parity function is actually performed on this bit.

## Byte Enable Support

Cyclone IV devices M9K memory blocks support byte enables that mask the input data so that only specific bytes of data are written. The unwritten bytes retain the previous written value. The `wren` signals, along with the byte-enable (`byteena`) signals, control the write operations of the RAM block. The default value of the `byteena` signals is high (enabled), in which case writing is controlled only by the `wren` signals. There is no clear port to the `byteena` registers. M9K blocks support byte enables when the write port has a data width of  $\times 16$ ,  $\times 18$ ,  $\times 32$ , or  $\times 36$  bits.

Byte enables operate in one-hot manner, with the LSB of the `byteena` signal corresponding to the least significant byte of the data bus. For example, if `byteena = 01` and you are using a RAM block in  $\times 18$  mode, data [8..0] is enabled and data [17..9] is disabled. Similarly, if `byteena = 11`, both data [8..0] and data [17..9] are enabled. Byte enables are active high.

Table 3-2 lists the byte selection.

**Table 3-2. `byteena` for Cyclone IV Devices M9K Blocks** <sup>(1)</sup>

<code>byteena[3..0]</code>	Affected Bytes			
	<code>datain <math>\times 16</math></code>	<code>datain <math>\times 18</math></code>	<code>datain <math>\times 32</math></code>	<code>datain <math>\times 36</math></code>
[0] = 1	[7..0]	[8..0]	[7..0]	[8..0]
[1] = 1	[15..8]	[17..9]	[15..8]	[17..9]
[2] = 1	—	—	[23..16]	[26..18]
[3] = 1	—	—	[31..24]	[35..27]

**Note to Table 3-2:**

(1) Any combination of byte enables is possible.

Figure 3-1 shows how the wren and byteena signals control the RAM operations.

**Figure 3-1. Cyclone IV Devices byteena Functional Waveform (1)**

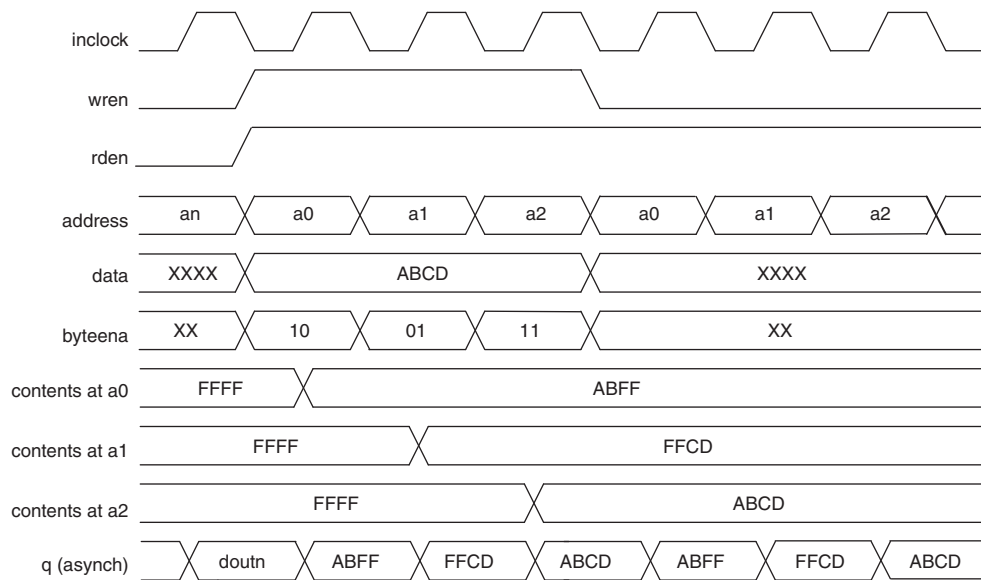

**Note to Figure 3-1:**

(1) For this functional waveform, **New Data** mode is selected.

When a byteena bit is deasserted during a write cycle, the old data in the memory appears in the corresponding data-byte output. When a byteena bit is asserted during a write cycle, the corresponding data-byte output depends on the setting chosen in the Quartus® II software. The setting can either be the newly written data or the old data at that location.



Byte enables are only supported for True Dual-Port memory configurations when both the PortA and PortB data widths of the individual M9K memory blocks are multiples of 8 or 9 bits.

## Packed Mode Support

Cyclone IV devices M9K memory blocks support packed mode. You can implement two single-port memory blocks in a single block under the following conditions:

- Each of the two independent block sizes is less than or equal to half of the M9K block size. The maximum data width for each independent block is 18 bits wide.
- Each of the single-port memory blocks is configured in single-clock mode. For more information about packed mode support, refer to [“Single-Port Mode” on page 3-8](#) and [“Single-Clock Mode” on page 3-15](#).

## Address Clock Enable Support

Cyclone IV devices M9K memory blocks support an active-low address clock enable, which holds the previous address value for as long as the `addressstall` signal is high (`addressstall = '1'`). When you configure M9K memory blocks in dual-port mode, each port has its own independent address clock enable.

Figure 3-2 shows an address clock enable block diagram. The address register output feeds back to its input using a multiplexer. The multiplexer output is selected by the address clock enable (`addressstall`) signal.

**Figure 3-2. Cyclone IV Devices Address Clock Enable Block Diagram**

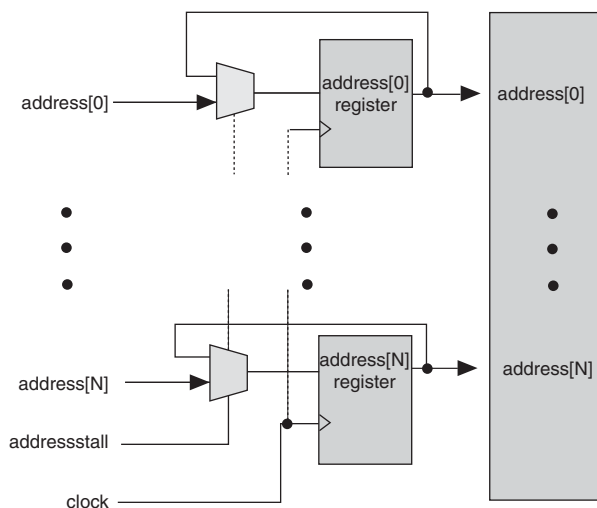

The address clock enable is typically used to improve the effectiveness of cache memory applications during a cache-miss. The default value for the address clock enable signals is low.

Figure 3-3 and Figure 3-4 show the address clock enable waveform during read and write cycles, respectively.

**Figure 3-3. Cyclone IV Devices Address Clock Enable During Read Cycle Waveform**

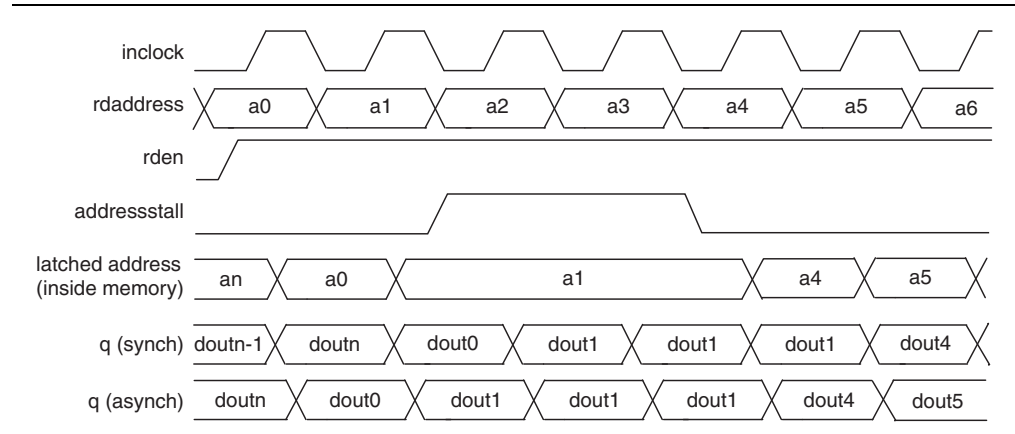

**Figure 3-4. Cyclone IV Devices Address Clock Enable During Write Cycle Waveform**

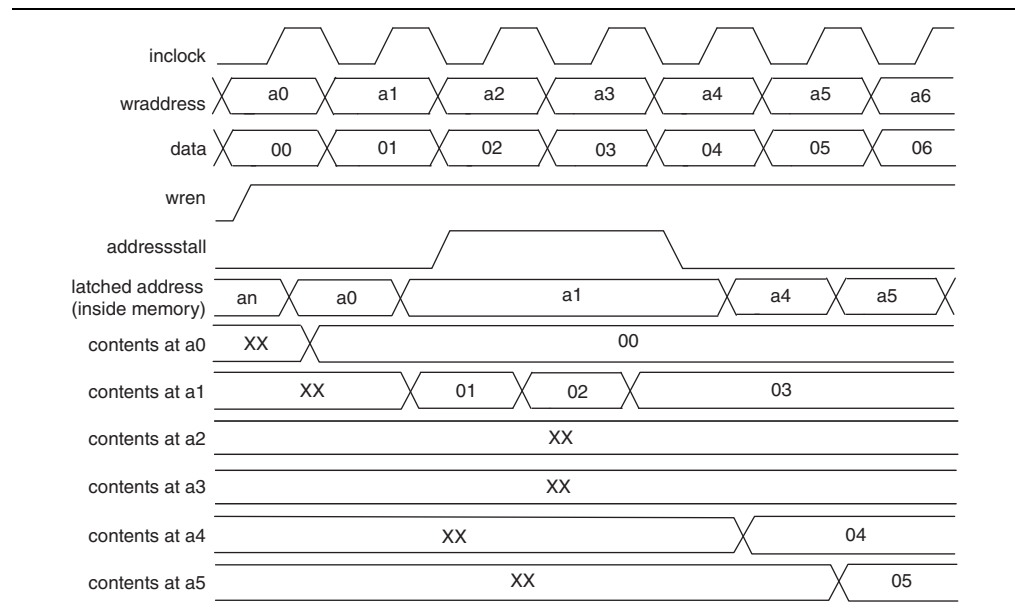

## Mixed-Width Support

M9K memory blocks support mixed data widths. When using simple dual-port, true dual-port, or FIFO modes, mixed width support allows you to read and write different data widths to an M9K memory block. For more information about the different widths supported per memory mode, refer to [“Memory Modes” on page 3-7](#).

## Asynchronous Clear

Cyclone IV devices support asynchronous clears for read address registers, output registers, and output latches only. Input registers other than read address registers are not supported. When applied to output registers, the asynchronous clear signal clears the output registers and the effects are immediately seen. If your RAM does not use output registers, you can still clear the RAM outputs using the output latch asynchronous clear feature.



 Asserting asynchronous clear to the read address register during a read operation may corrupt the memory content.

Figure 3-5 shows the functional waveform for the asynchronous clear feature.

**Figure 3-5. Output Latch Asynchronous Clear Waveform**

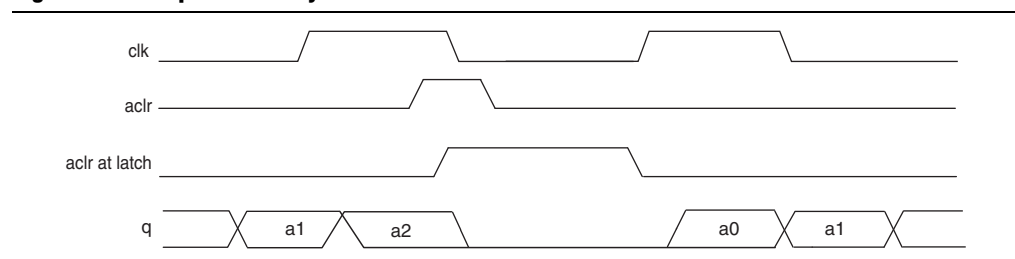

 You can selectively enable asynchronous clears per logical memory using the Quartus II RAM MegaWizard™ Plug-In Manager.

 For more information, refer to the [RAM Megafunction User Guide](#).

There are three ways to reset registers in the M9K blocks:

- Power up the device
- Use the `aclr` signal for output register only
- Assert the device-wide reset signal using the `DEV_CLRn` option

## Memory Modes

Cyclone IV devices M9K memory blocks allow you to implement fully-synchronous SRAM memory in multiple modes of operation. Cyclone IV devices M9K memory blocks do not support asynchronous (unregistered) memory inputs.

M9K memory blocks support the following modes:

- Single-port
- Simple dual-port
- True dual-port
- Shift-register
- ROM
- FIFO

 Violating the setup or hold time on the M9K memory block input registers may corrupt memory contents. This applies to both read and write operations.

## Single-Port Mode

Single-port mode supports non-simultaneous read and write operations from a single address. [Figure 3-6](#) shows the single-port memory configuration for Cyclone IV devices M9K memory blocks.

**Figure 3-6. Single-Port Memory** <sup>(1)</sup>, <sup>(2)</sup>

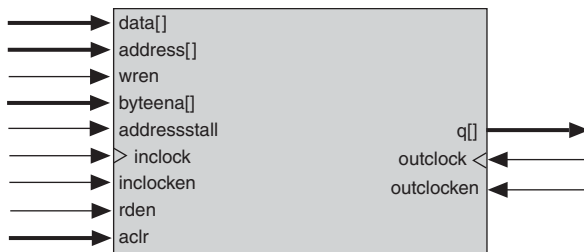

**Notes to [Figure 3-6](#):**

- (1) You can implement two single-port memory blocks in a single M9K block.
- (2) For more information, refer to [“Packed Mode Support”](#) on page 3-4.

During a write operation, the behavior of the RAM outputs is configurable. If you activate rden during a write operation, the RAM outputs show either the new data being written or the old data at that address. If you perform a write operation with rden deactivated, the RAM outputs retain the values they held during the most recent active rden signal.

To choose the desired behavior, set the **Read-During-Write** option to either **New Data** or **Old Data** in the RAM MegaWizard Plug-In Manager in the Quartus II software. For more information about read-during-write mode, refer to [“Read-During-Write Operations”](#) on page 3-15.

The port width configurations for M9K blocks in single-port mode are as follow:

- 8192 × 1
- 4096 × 2
- 2048 × 4
- 1024 × 8
- 1024 × 9
- 512 × 16
- 512 × 18
- 256 × 32
- 256 × 36

Figure 3-7 shows a timing waveform for read and write operations in single-port mode with unregistered outputs. Registering the outputs of the RAM simply delays the q output by one clock cycle.

**Figure 3-7. Cyclone IV Devices Single-Port Mode Timing Waveform**

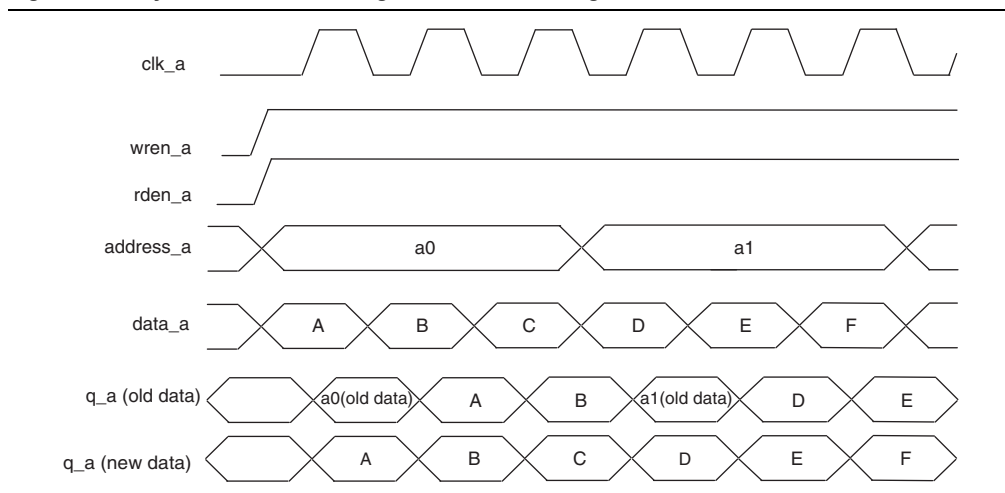

## Simple Dual-Port Mode

Simple dual-port mode supports simultaneous read and write operations to different locations. Figure 3-8 shows the simple dual-port memory configuration.

**Figure 3-8. Cyclone IV Devices Simple Dual-Port Memory (1)**

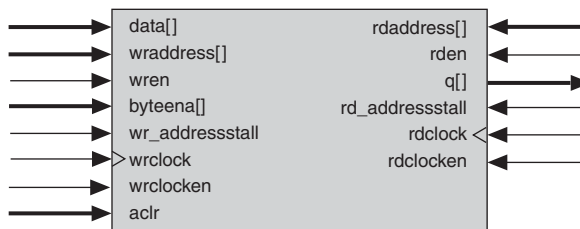

**Note to Figure 3-8:**

(1) Simple dual-port RAM supports input or output clock mode in addition to the read or write clock mode shown.

Cyclone IV devices M9K memory blocks support mixed-width configurations, allowing different read and write port widths. Table 3-3 lists mixed-width configurations.

**Table 3-3. Cyclone IV Devices M9K Block Mixed-Width Configurations (Simple Dual-Port Mode) (Part 1 of 2)**

Read Port	Write Port								
	8192 × 1	4096 × 2	2048 × 4	1024 × 8	512 × 16	256 × 32	1024 × 9	512 × 18	256 × 36
8192 × 1	✓	✓	✓	✓	✓	✓	—	—	—
4096 × 2	✓	✓	✓	✓	✓	✓	—	—	—
2048 × 4	✓	✓	✓	✓	✓	✓	—	—	—
1024 × 8	✓	✓	✓	✓	✓	✓	—	—	—

**Table 3-3. Cyclone IV Devices M9K Block Mixed-Width Configurations (Simple Dual-Port Mode) (Part 2 of 2)**

Read Port	Write Port								
	8192 × 1	4096 × 2	2048 × 4	1024 × 8	512 × 16	256 × 32	1024 × 9	512 × 18	256 × 36
512 × 16	✓	✓	✓	✓	✓	✓	—	—	—
256 × 32	✓	✓	✓	✓	✓	✓	—	—	—
1024 × 9	—	—	—	—	—	—	✓	✓	✓
512 × 18	—	—	—	—	—	—	✓	✓	✓
256 × 36	—	—	—	—	—	—	✓	✓	✓

In simple dual-port mode, M9K memory blocks support separate *wren* and *rden* signals. You can save power by keeping the *rden* signal low (inactive) when not reading. Read-during-write operations to the same address can either output “Don’t Care” data at that location or output “Old Data”. To choose the desired behavior, set the **Read-During-Write** option to either **Don’t Care** or **Old Data** in the RAM MegaWizard Plug-In Manager in the Quartus II software. For more information about this behavior, refer to [“Read-During-Write Operations” on page 3-15](#).

[Figure 3-9](#) shows the timing waveform for read and write operations in simple dual-port mode with unregistered outputs. Registering the outputs of the RAM simply delays the *q* output by one clock cycle.

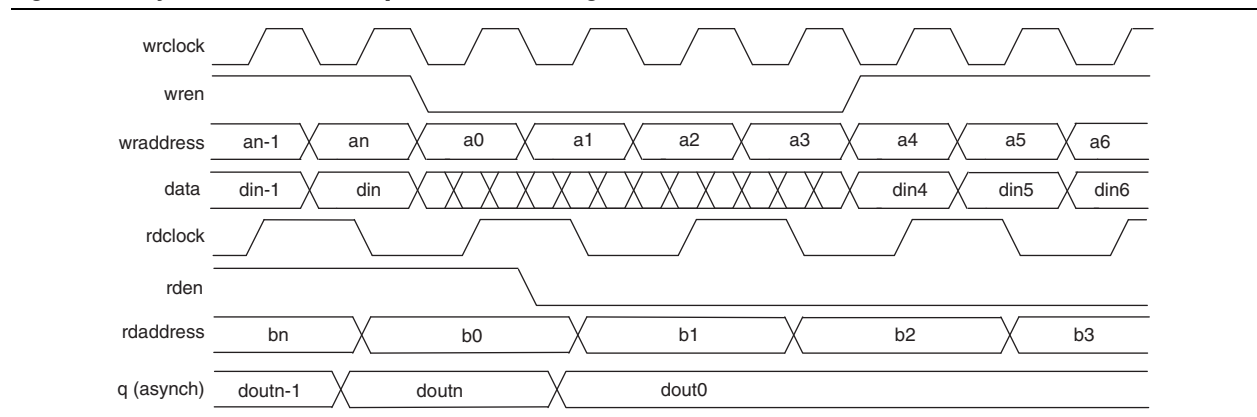
**Figure 3-9. Cyclone IV Devices Simple Dual-Port Timing Waveform**

## True Dual-Port Mode

True dual-port mode supports any combination of two-port operations: two reads, two writes, or one read and one write, at two different clock frequencies. Figure 3-10 shows Cyclone IV devices true dual-port memory configuration.

**Figure 3-10. Cyclone IV Devices True Dual-Port Memory** (1)

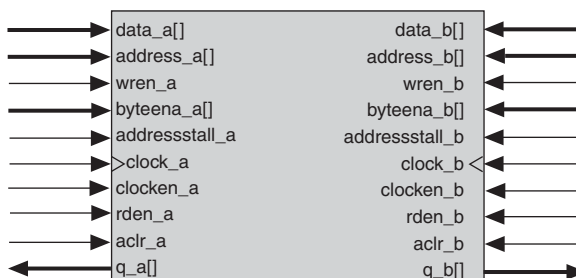

**Note to Figure 3-10:**

(1) True dual-port memory supports input or output clock mode in addition to the independent clock mode shown.



The widest bit configuration of the M9K blocks in true dual-port mode is 512 × 16-bit (18-bit with parity).

Table 3-4 lists the possible M9K block mixed-port width configurations.

**Table 3-4. Cyclone IV Devices M9K Block Mixed-Width Configurations (True Dual-Port Mode)**

Read Port	Write Port						
	8192 × 1	4096 × 2	2048 × 4	1024 × 8	512 × 16	1024 × 9	512 × 18
8192 × 1	✓	✓	✓	✓	✓	—	—
4096 × 2	✓	✓	✓	✓	✓	—	—
2048 × 4	✓	✓	✓	✓	✓	—	—
1024 × 8	✓	✓	✓	✓	✓	—	—
512 × 16	✓	✓	✓	✓	✓	—	—
1024 × 9	—	—	—	—	—	✓	✓
512 × 18	—	—	—	—	—	✓	✓

In true dual-port mode, M9K memory blocks support separate wren and rden signals. You can save power by keeping the rden signal low (inactive) when not reading. Read-during-write operations to the same address can either output “New Data” at that location or “Old Data”. To choose the desired behavior, set the **Read-During-Write** option to either **New Data** or **Old Data** in the RAM MegaWizard Plug-In Manager in the Quartus II software. For more information about this behavior, refer to “Read-During-Write Operations” on page 3-15.

In true dual-port mode, you can access any memory location at any time from either port A or port B. However, when accessing the same memory location from both ports, you must avoid possible write conflicts. When you attempt to write to the same address location from both ports at the same time, a write conflict happens. This results in unknown data being stored to that address location. There is no conflict resolution circuitry built into the Cyclone IV devices M9K memory blocks. You must handle address conflicts external to the RAM block.

Figure 3-11 shows true dual-port timing waveforms for the write operation at port A and read operation at port B. Registering the outputs of the RAM simply delays the *q* outputs by one clock cycle.

**Figure 3-11. Cyclone IV Devices True Dual-Port Timing Waveform**

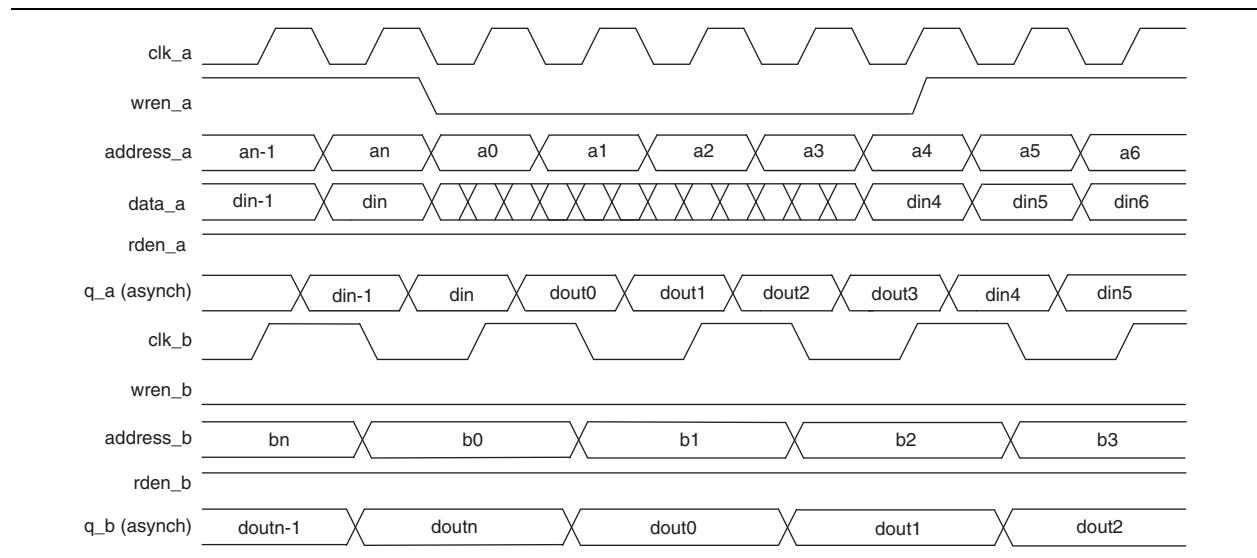

## Shift Register Mode

Cyclone IV devices M9K memory blocks can implement shift registers for digital signal processing (DSP) applications, such as finite impulse response (FIR) filters, pseudo-random number generators, multi-channel filtering, and auto-correlation and cross-correlation functions. These and other DSP applications require local data storage, traditionally implemented with standard flipflops that quickly exhaust many logic cells for large shift registers. A more efficient alternative is to use embedded memory as a shift register block, which saves logic cell and routing resources.

The size of a ( $w \times m \times n$ ) shift register is determined by the input data width ( $w$ ), the length of the taps ( $m$ ), and the number of taps ( $n$ ), and must be less than or equal to the maximum number of memory bits, which is 9,216 bits. In addition, the size of ( $w \times n$ ) must be less than or equal to the maximum width of the block, which is 36 bits. If you need a larger shift register, you can cascade the M9K memory blocks.

Figure 3-12 shows the Cyclone IV devices M9K memory block in shift register mode.

**Figure 3-12. Cyclone IV Devices Shift Register Mode Configuration**

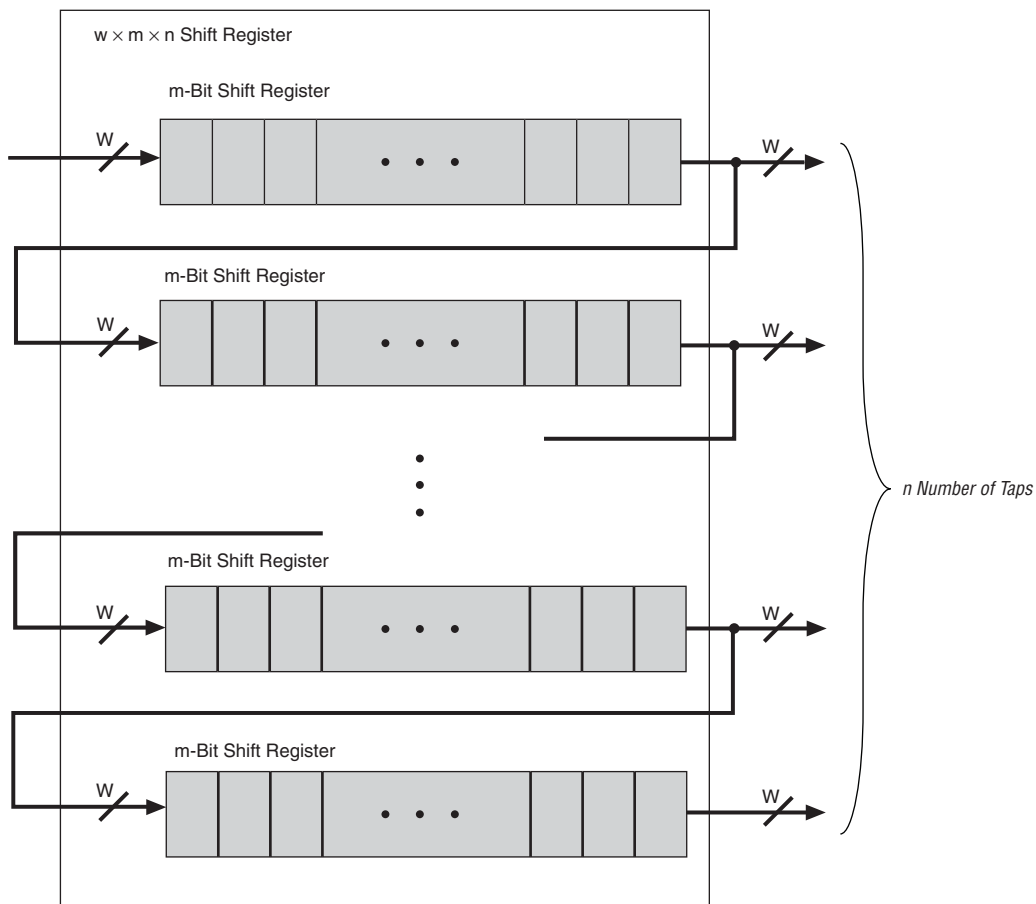

## ROM Mode

Cyclone IV devices M9K memory blocks support ROM mode. A `.mif` initializes the ROM contents of these blocks. The address lines of the ROM are registered. The outputs can be registered or unregistered. The ROM read operation is identical to the read operation in the single-port RAM configuration.

## FIFO Buffer Mode

Cyclone IV devices M9K memory blocks support single-clock or dual-clock FIFO buffers. Dual clock FIFO buffers are useful when transferring data from one clock domain to another clock domain. Cyclone IV devices M9K memory blocks do not support simultaneous read and write from an empty FIFO buffer.

 For more information about FIFO buffers, refer to the [Single- and Dual-Clock FIFO Megafunction User Guide](#).

## Clocking Modes

Cyclone IV devices M9K memory blocks support the following clocking modes:

- Independent
- Input or output
- Read or write
- Single-clock

When using read or write clock mode, if you perform a simultaneous read or write to the same address location, the output read data is unknown. If you require the output data to be a known value, use either single-clock mode or I/O clock mode and choose the appropriate read-during-write behavior in the MegaWizard Plug-In Manager.

 Violating the setup or hold time on the memory block input registers might corrupt the memory contents. This applies to both read and write operations.

 Asynchronous clears are available on read address registers, output registers, and output latches only.

Table 3-5 lists the clocking mode versus memory mode support matrix.

**Table 3-5. Cyclone IV Devices Memory Clock Modes**

Clocking Mode	True Dual-Port Mode	Simple Dual-Port Mode	Single-Port Mode	ROM Mode	FIFO Mode
Independent	✓	—	—	✓	—
Input or output	✓	✓	✓	✓	—
Read or write	—	✓	—	—	✓
Single-clock	✓	✓	✓	✓	✓

### Independent Clock Mode

Cyclone IV devices M9K memory blocks can implement independent clock mode for true dual-port memories. In this mode, a separate clock is available for each port (port A and port B). `clock A` controls all registers on the port A side, while `clock B` controls all registers on the port B side. Each port also supports independent clock enables for port A and B registers.

### Input or Output Clock Mode

Cyclone IV devices M9K memory blocks can implement input or output clock mode for FIFO, single-port, true, and simple dual-port memories. In this mode, an input clock controls all input registers to the memory block including data, address, `byteena`, `wren`, and `rden` registers. An output clock controls the data-output registers. Each memory block port also supports independent clock enables for input and output registers.

## Read or Write Clock Mode

Cyclone IV devices M9K memory blocks can implement read or write clock mode for FIFO and simple dual-port memories. In this mode, a write clock controls the data inputs, write address, and wren registers. Similarly, a read clock controls the data outputs, read address, and rden registers. M9K memory blocks support independent clock enables for both the read and write clocks.

When using read or write mode, if you perform a simultaneous read or write to the same address location, the output read data is unknown. If you require the output data to be a known value, use either single-clock mode, input clock mode, or output clock mode and choose the appropriate read-during-write behavior in the MegaWizard Plug-In Manager.

## Single-Clock Mode

Cyclone IV devices M9K memory blocks can implement single-clock mode for FIFO, ROM, true dual-port, simple dual-port, and single-port memories. In this mode, you can control all registers of the M9K memory block with a single clock together with clock enable.

## Design Considerations

This section describes designing with M9K memory blocks.

### Read-During-Write Operations

“Same-Port Read-During-Write Mode” on page 3-16 and “Mixed-Port Read-During-Write Mode” on page 3-16 describe the functionality of the various RAM configurations when reading from an address during a write operation at that same address.

There are two read-during-write data flows: same-port and mixed-port. Figure 3-13 shows the difference between these flows.

**Figure 3-13. Cyclone IV Devices Read-During-Write Data Flow**

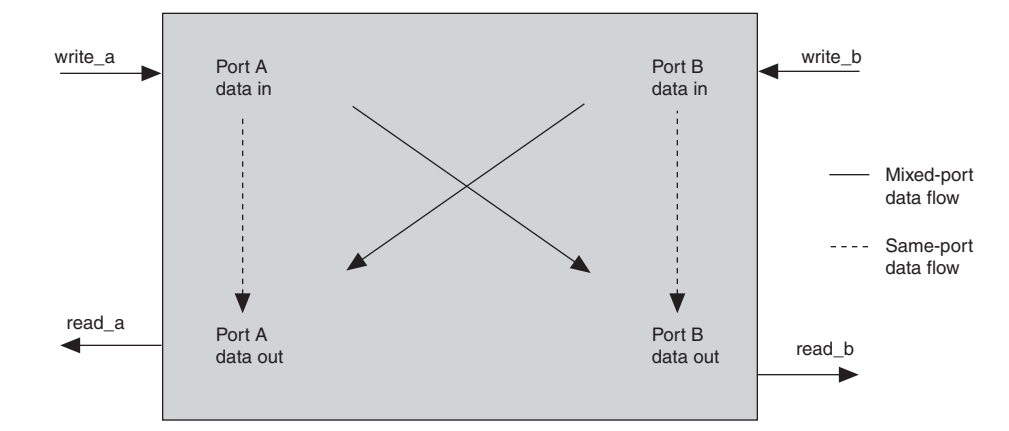

### Same-Port Read-During-Write Mode

This mode applies to a single-port RAM or the same port of a true dual-port RAM. In the same port read-during-write mode, there are two output choices: **New Data** mode (or flow-through) and **Old Data** mode. In **New Data** mode, new data is available on the rising edge of the same clock cycle on which it was written. In **Old Data** mode, the RAM outputs reflect the old data at that address before the write operation proceeds.

When using **New Data** mode together with *byteena*, you can control the output of the RAM. When *byteena* is high, the data written into the memory passes to the output (flow-through). When *byteena* is low, the masked-off data is not written into the memory and the old data in the memory appears on the outputs. Therefore, the output can be a combination of new and old data determined by *byteena*.

Figure 3-14 and Figure 3-15 show sample functional waveforms of same port read-during-write behavior with both **New Data** and **Old Data** modes, respectively.

**Figure 3-14. Same Port Read-During Write: New Data Mode**

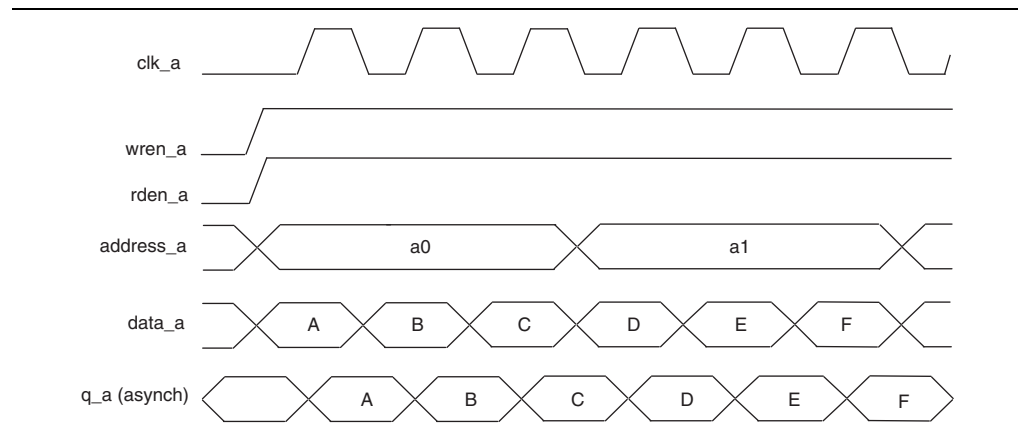

**Figure 3-15. Same Port Read-During-Write: Old Data Mode**

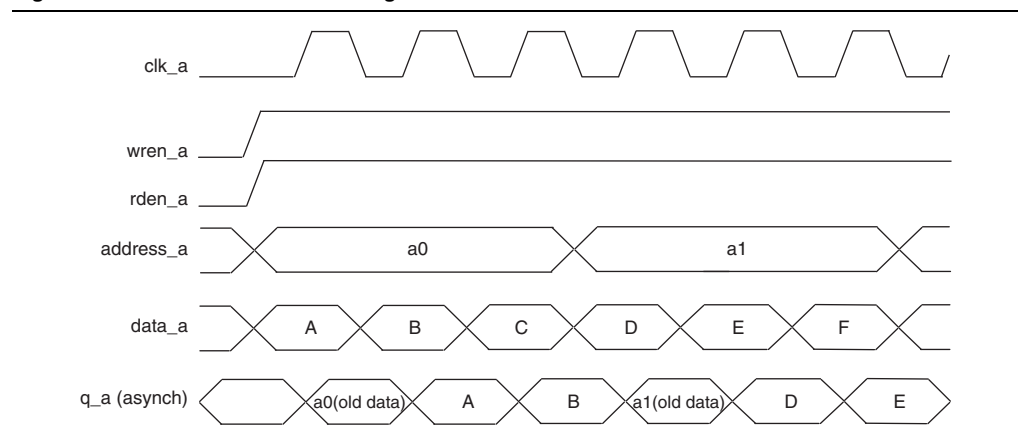

### Mixed-Port Read-During-Write Mode

This mode applies to a RAM in simple or true dual-port mode, which has one port reading and the other port writing to the same address location with the same clock.

In this mode, you also have two output choices: **Old Data** mode or **Don't Care** mode. In **Old Data** mode, a read-during-write operation to different ports causes the RAM outputs to reflect the old data at that address location. In **Don't Care** mode, the same operation results in a “Don't Care” or unknown value on the RAM outputs.



 For more information about how to implement the desired behavior, refer to the [RAM Megafunction User Guide](#).

Figure 3-16 shows a sample functional waveform of mixed port read-during-write behavior for **Old Data** mode. In **Don't Care** mode, the old data is replaced with “Don't Care”.

**Figure 3-16. Mixed Port Read-During-Write: Old Data Mode**

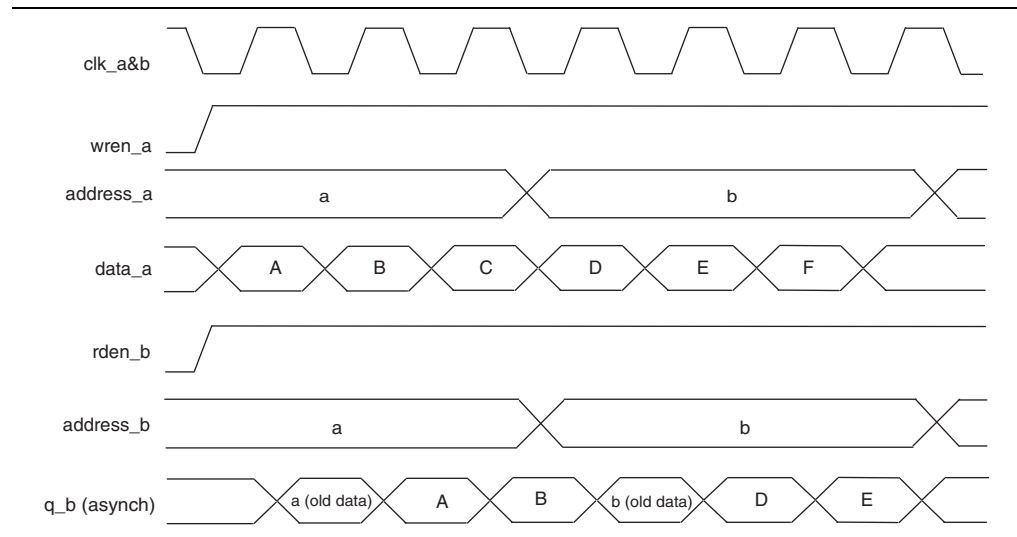

 For mixed-port read-during-write operation with dual clocks, the relationship between the clocks determines the output behavior of the memory. If you use the same clock for the two clocks, the output is the old data from the address location. However, if you use different clocks, the output is unknown during the mixed-port read-during-write operation. This unknown value may be the old or new data at the address location, depending on whether the read happens before or after the write.

## Conflict Resolution

When you are using M9K memory blocks in true dual-port mode, it is possible to attempt two write operations to the same memory location (address). Because there is no conflict resolution circuitry built into M9K memory blocks, this results in unknown data being written to that location. Therefore, you must implement conflict-resolution logic external to the M9K memory block.

## Power-Up Conditions and Memory Initialization

The M9K memory block outputs of Cyclone IV devices power up to zero (cleared) regardless of whether the output registers are used or bypassed. All M9K memory blocks support initialization using a `.mif`. You can create `.mifs` in the Quartus II software and specify their use using the RAM MegaWizard Plug-In Manager when instantiating memory in your design. Even if memory is pre-initialized (for example, using a `.mif`), it still powers up with its outputs cleared. Only the subsequent read after power up outputs the pre-initialized values.



For more information about `.mifs`, refer to the *RAM Megafunction User Guide* and the *Quartus II Handbook*.

## Power Management

The M9K memory block clock enables of Cyclone IV devices allow you to control clocking of each M9K memory block to reduce AC power consumption. Use the `rden` signal to ensure that read operations only occur when necessary. If your design does not require read-during-write, reduce power consumption by deasserting the `rden` signal during write operations or any period when there are no memory operations. The Quartus II software automatically powers down any unused M9K memory blocks to save static power.

## Document Revision History

Table 3-6 shows the revision history for this chapter.

**Table 3-6. Document Revision History**

Date	Version	Changes
November 2011	1.1	Updated the “Byte Enable Support” section.
November 2009	1.0	Initial release.

Cyclone® IV devices include a combination of on-chip resources and external interfaces that help increase performance, reduce system cost, and lower the power consumption of digital signal processing (DSP) systems. Cyclone IV devices, either alone or as DSP device co-processors, are used to improve price-to-performance ratios of DSP systems. Particular focus is placed on optimizing Cyclone IV devices for applications that benefit from an abundance of parallel processing resources, which include video and image processing, intermediate frequency (IF) modems used in wireless communications systems, and multi-channel communications and video systems.

This chapter contains the following sections:

- “Embedded Multiplier Block Overview” on page 4-1
- “Architecture” on page 4-2
- “Operational Modes” on page 4-4

## Embedded Multiplier Block Overview

Figure 4-1 shows one of the embedded multiplier columns with the surrounding logic array blocks (LABs). The embedded multiplier is configured as either one  $18 \times 18$  multiplier or two  $9 \times 9$  multipliers. For multiplications greater than  $18 \times 18$ , the Quartus® II software cascades multiple embedded multiplier blocks together. There are no restrictions on the data width of the multiplier, but the greater the data width, the slower the multiplication process.

**Figure 4-1. Embedded Multipliers Arranged in Columns with Adjacent LABs**

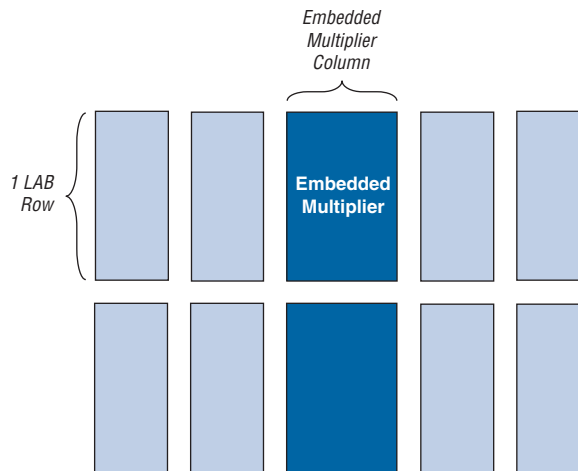

© 2010 Altera Corporation. All rights reserved. ALTERA, ARRIA, CYCLONE, HARDCOPY, MAX, MEGACORE, NIOS, QUARTUS and STRATIX words and logos are trademarks of Altera Corporation and registered in the U.S. Patent and Trademark Office and in other countries. All other words and logos identified as trademarks or service marks are the property of their respective holders as described at [www.altera.com/common/legal.html](http://www.altera.com/common/legal.html). Altera warrants performance of its semiconductor products to current specifications in accordance with Altera's standard warranty, but reserves the right to make changes to any products and services at any time without notice. Altera assumes no responsibility or liability arising out of the application or use of any information, product, or service described herein except as expressly agreed to in writing by Altera. Altera customers are advised to obtain the latest version of device specifications before relying on any published information and before placing orders for products or services.



Table 4-1 lists the number of embedded multipliers and the multiplier modes that can be implemented in each Cyclone IV device.

**Table 4-1. Number of Embedded Multipliers in Cyclone IV Devices**

Device Family	Device	Embedded Multipliers	9 × 9 Multipliers <sup>(1)</sup>	18 × 18 Multipliers <sup>(1)</sup>
Cyclone IV GX	EP4CGX15	0	0	0
	EP4CGX22	40	80	40
	EP4CGX30	80	160	80
	EP4CGX50	140	280	140
	EP4CGX75	198	396	198
	EP4CGX110	280	560	280
	EP4CGX150	360	720	360
Cyclone IV E	EP4CE6	15	30	15
	EP4CE10	23	46	23
	EP4CE15	56	112	56
	EP4CE22	66	132	66
	EP4CE30	66	132	66
	EP4CE40	116	232	116
	EP4CE55	154	308	154
	EP4CE75	200	400	200
	EP4CE115	266	532	266

**Note to Table 4-1:**

(1) These columns show the number of 9 × 9 or 18 × 18 multipliers for each device.

In addition to the embedded multipliers in Cyclone IV devices, you can implement soft multipliers by using the M9K memory blocks as look-up tables (LUTs). The LUTs contain partial results from the multiplication of input data with coefficients that implement variable depth and width high-performance soft multipliers for low-cost, high-volume DSP applications. The availability of soft multipliers increases the number of available multipliers in the device.



For more information about M9K memory blocks, refer to the *Memory Blocks in Cyclone IV Devices* chapter.



For more information about soft multipliers, refer to *AN 306: Implementing Multipliers in FPGA Devices*.

## Architecture

Each embedded multiplier consists of the following elements:

- Multiplier stage
- Input and output registers
- Input and output interfaces

Figure 4-2 shows the multiplier block architecture.

**Figure 4-2. Multiplier Block Architecture**

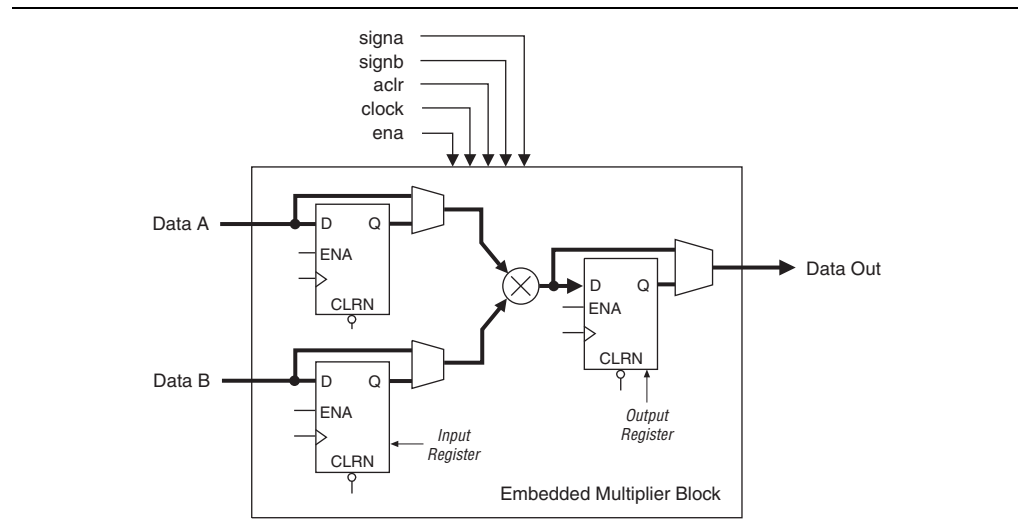

## Input Registers

You can send each multiplier input signal into an input register or directly into the multiplier in 9- or 18-bit sections, depending on the operational mode of the multiplier. You can send each multiplier input signal through a register independently of other input signals. For example, you can send the multiplier Data A signal through a register and send the Data B signal directly to the multiplier.

The following control signals are available for each input register in the embedded multiplier:

- clock
- clock enable
- asynchronous clear

All input and output registers in a single embedded multiplier are fed by the same clock, clock enable, and asynchronous clear signals.

## Multiplier Stage

The multiplier stage of an embedded multiplier block supports  $9 \times 9$  or  $18 \times 18$  multipliers, as well as other multipliers between these configurations. Depending on the data width or operational mode of the multiplier, a single embedded multiplier can perform one or two multiplications in parallel. For multiplier information, refer to “Operational Modes” on page 4-4.

Each multiplier operand is a unique signed or unsigned number. The *signa* and *signb* signals control an input of a multiplier and determine if the value is signed or unsigned. If the *signa* signal is high, the Data A operand is a signed number. If the *signa* signal is low, the Data A operand is an unsigned number.

Table 4–2 lists the sign of the multiplication results for the various operand sign representations. The results of the multiplication are signed if any one of the operands is a signed value.

**Table 4–2. Multiplier Sign Representation**

Data A		Data B		Result
signa Value	Logic Level	signb Value	Logic Level	
Unsigned	Low	Unsigned	Low	Unsigned
Unsigned	Low	Signed	High	Signed
Signed	High	Unsigned	Low	Signed
Signed	High	Signed	High	Signed

Each embedded multiplier block has only one *signa* and one *signb* signal to control the sign representation of the input data to the block. If the embedded multiplier block has two  $9 \times 9$  multipliers, the *Data A* input of both multipliers share the same *signa* signal, and the *Data B* input of both multipliers share the same *signb* signal. You can dynamically change the *signa* and *signb* signals to modify the sign representation of the input operands at run time. You can send the *signa* and *signb* signals through a dedicated input register. The multiplier offers full precision, regardless of the sign representation.



When the *signa* and *signb* signals are unused, the Quartus II software sets the multiplier to perform unsigned multiplication by default.

## Output Registers

You can register the embedded multiplier output with output registers in either 18- or 36-bit sections, depending on the operational mode of the multiplier. The following control signals are available for each output register in the embedded multiplier:

- clock
- clock enable
- asynchronous clear

All input and output registers in a single embedded multiplier are fed by the same clock, clock enable, and asynchronous clear signals.

## Operational Modes

You can use an embedded multiplier block in one of two operational modes, depending on the application needs:

- One  $18 \times 18$  multiplier
- Up to two  $9 \times 9$  independent multipliers



You can also use embedded multipliers of Cyclone IV devices to implement multiplier adder and multiplier accumulator functions, in which the multiplier portion of the function is implemented with embedded multipliers, and the adder or accumulator function is implemented in logic elements (LEs).

## 18-Bit Multipliers

You can configure each embedded multiplier to support a single  $18 \times 18$  multiplier for input widths of 10 to 18 bits.

Figure 4-3 shows the embedded multiplier configured to support an 18-bit multiplier.

Figure 4-3. 18-Bit Multiplier Mode

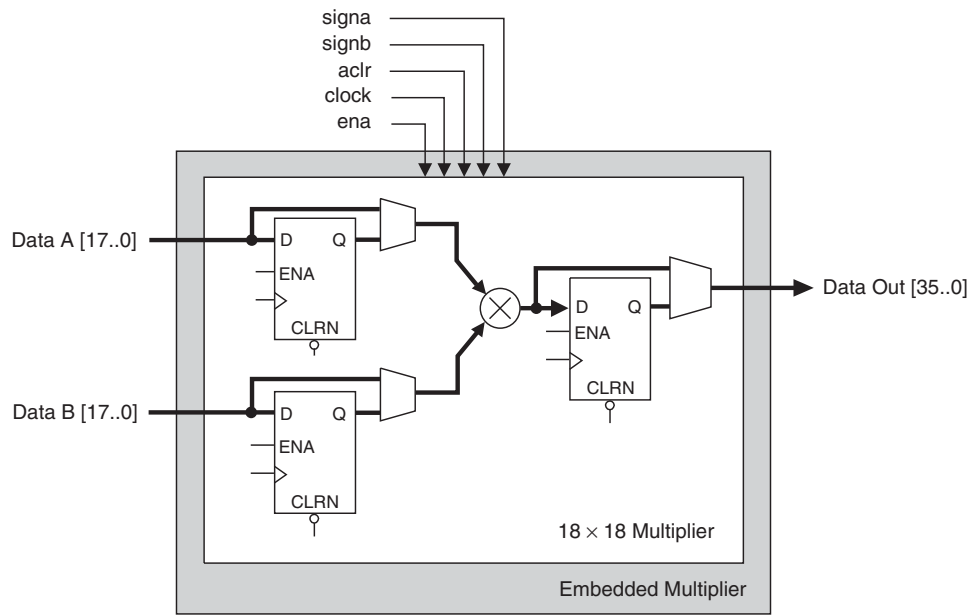

All 18-bit multiplier inputs and results are independently sent through registers. The multiplier inputs can accept signed integers, unsigned integers, or a combination of both. Also, you can dynamically change the *signa* and *signb* signals and send these signals through dedicated input registers.

## 9-Bit Multipliers

You can configure each embedded multiplier to support two  $9 \times 9$  independent multipliers for input widths of up to 9 bits.

Figure 4-4 shows the embedded multiplier configured to support two 9-bit multipliers.

**Figure 4-4. 9-Bit Multiplier Mode**

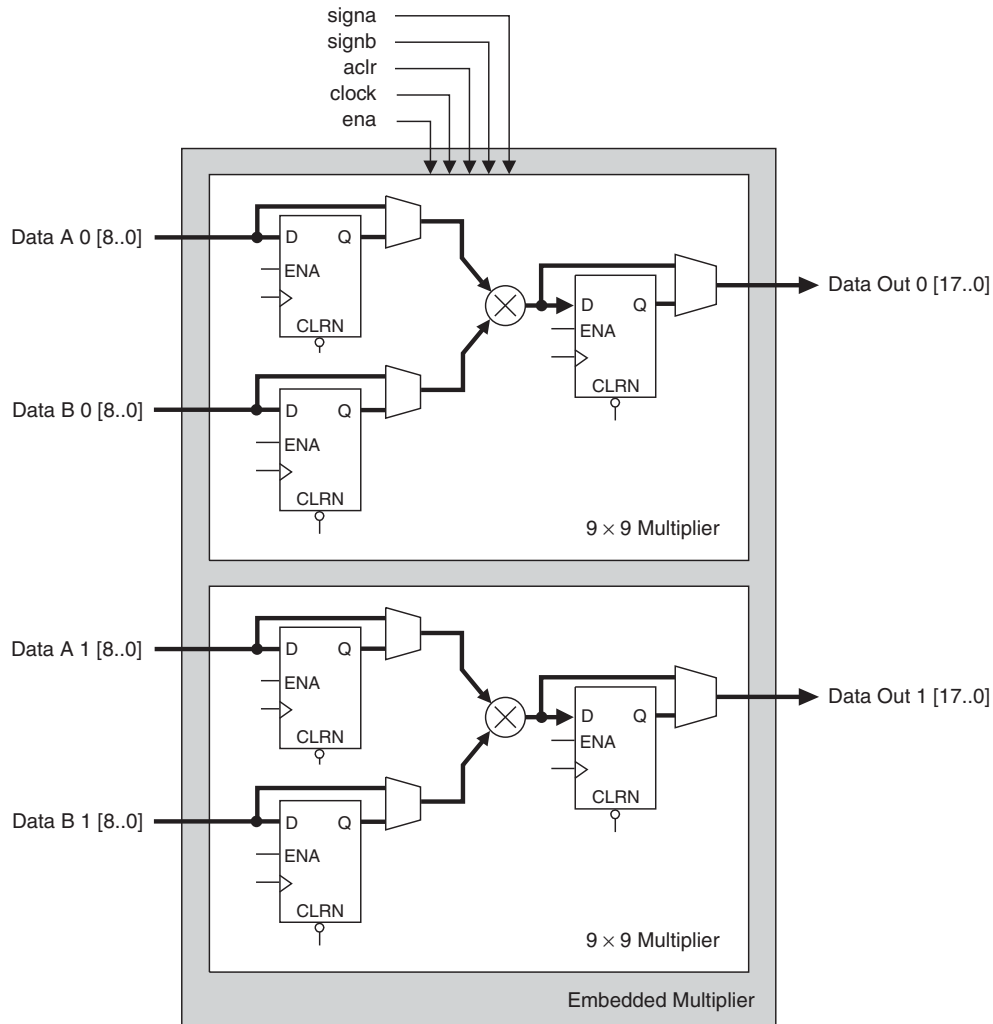

All 9-bit multiplier inputs and results are independently sent through registers. The multiplier inputs can accept signed integers, unsigned integers, or a combination of both. Two  $9 \times 9$  multipliers in the same embedded multiplier block share the same *signa* and *signb* signal. Therefore, all the Data A inputs feeding the same embedded multiplier must have the same sign representation. Similarly, all the Data B inputs feeding the same embedded multiplier must have the same sign representation.

## Document Revision History

Table 4-3 lists the revision history for this chapter.

**Table 4-3. Document Revision History**

Date	Version	Changes
February 2010	1.1	Added Cyclone IV E devices in Table 4-1 for the Quartus II software version 9.1 SP1 release.
November 2009	1.0	Initial release.



This chapter describes the hierarchical clock networks and phase-locked loops (PLLs) with advanced features in the Cyclone® IV device family. It includes details about the ability to reconfigure the PLL counter clock frequency and phase shift in real time, allowing you to sweep PLL output frequencies and dynamically adjust the output clock phase shift.

 The Quartus® II software enables the PLLs and their features without external devices.

This chapter contains the following sections:

- “Clock Networks” on page 5–1
- “PLLs in Cyclone IV Devices” on page 5–18
- “Cyclone IV PLL Hardware Overview” on page 5–20
- “Clock Feedback Modes” on page 5–23
- “Hardware Features” on page 5–26
- “Programmable Bandwidth” on page 5–32
- “Phase Shift Implementation” on page 5–32
- “PLL Cascading” on page 5–33
- “PLL Reconfiguration” on page 5–34
- “Spread-Spectrum Clocking” on page 5–41
- “PLL Specifications” on page 5–41

## Clock Networks

The Cyclone IV GX device provides up to 12 dedicated clock pins (CLK[15..4]) that can drive the global clocks (GCLKs). Cyclone IV GX devices support four dedicated clock pins on each side of the device except the left side. These clock pins can drive up to 30 GCLKs.

The Cyclone IV E device provides up to 15 dedicated clock pins (CLK[15..1]) that can drive up to 20 GCLKs. Cyclone IV E devices support three dedicated clock pins on the left side and four dedicated clock pins on the top, right, and bottom sides of the device except EP4CE6 and EP4CE10 devices. EP4CE6 and EP4CE10 devices only support three dedicated clock pins on the left side and four dedicated clock pins on the right side of the device.

 For more information about the number of GCLK networks in each device density, refer to the *Cyclone IV FPGA Device Family Overview* chapter.

## GCLK Network

GCLKs drive throughout the entire device, feeding all device quadrants. All resources in the device (I/O elements, logic array blocks (LABs), dedicated multiplier blocks, and M9K memory blocks) can use GCLKs as clock sources. Use these clock network resources for control signals, such as clock enables and clears fed by an external pin. Internal logic can also drive GCLKs for internally generated GCLKs and asynchronous clears, clock enables, or other control signals with high fan-out.

Table 5-1, Table 5-2 on page 5-4, and Table 5-3 on page 5-7 list the connectivity of the clock sources to the GCLK networks.

**Table 5-1. GCLK Network Connections for EP4CGX15, EP4CGX22, and EP4CGX30 <sup>(1)</sup>, <sup>(2)</sup> (Part 1 of 2)**

GCLK Network Clock Sources	GCLK Networks																			
	0	1	2	3	4	5	6	7	8	9	10	11	12	13	14	15	16	17	18	19
CLK4/DIFFCLK_2n	—	—	—	—	—	✓	—	✓	—	✓	—	—	—	—	—	—	—	—	—	—
CLK5/DIFFCLK_2p	—	—	—	—	—	—	✓	✓	—	—	—	—	—	—	—	—	—	—	—	—
CLK6/DIFFCLK_3n	—	—	—	—	—	—	✓	—	✓	✓	—	—	—	—	—	—	—	—	—	—
CLK7/DIFFCLK_3p	—	—	—	—	—	✓	—	—	✓	—	—	—	—	—	—	—	—	—	—	—
CLK8/DIFFCLK_5n	—	—	—	—	—	—	—	—	—	—	✓	—	✓	—	✓	—	—	—	—	—
CLK9/DIFFCLK_5p	—	—	—	—	—	—	—	—	—	—	—	✓	✓	—	—	—	—	—	—	—
CLK10/DIFFCLK_4n/RE FCLK1n	—	—	—	—	—	—	—	—	—	—	—	—	✓	—	✓	✓	—	—	—	—
CLK11/DIFFCLK_4p/RE FCLK1p	—	—	—	—	—	—	—	—	—	—	—	—	—	—	✓	—	—	—	—	—
CLK12/DIFFCLK_7p/RE FCLK0p	—	—	—	—	—	—	—	—	—	—	—	—	—	—	—	—	✓	—	✓	—
CLK13/DIFFCLK_7n/RE FCLK0n	—	—	—	—	—	—	—	—	—	—	—	—	—	—	—	—	—	✓	✓	—
CLK14/DIFFCLK_6p	—	—	—	—	—	—	—	—	—	—	—	—	—	—	—	—	—	—	✓	✓
CLK15/DIFFCLK_6n	—	—	—	—	—	—	—	—	—	—	—	—	—	—	—	—	—	—	—	✓
PLL_1_C0	✓	—	—	✓	—	—	—	—	—	—	—	—	—	—	—	—	—	—	—	✓
PLL_1_C1	—	✓	—	—	✓	—	—	—	—	—	—	—	—	—	—	—	—	—	—	✓
PLL_1_C2	✓	—	✓	—	—	—	—	—	—	—	—	—	—	—	—	—	—	—	—	✓
PLL_1_C3	—	✓	—	✓	—	—	—	—	—	—	—	—	—	—	—	—	—	—	—	✓
PLL_1_C4	—	—	✓	—	✓	—	—	—	—	—	—	—	—	—	—	—	—	—	—	✓
PLL_2_C0	✓	—	—	✓	—	—	—	—	—	—	—	—	—	—	—	—	—	—	—	—
PLL_2_C1	—	✓	—	—	✓	—	—	—	—	—	—	—	—	—	—	—	—	—	—	—
PLL_2_C2	✓	—	✓	—	—	—	—	—	—	—	—	—	—	—	—	—	—	—	—	—
PLL_2_C3	—	✓	—	✓	—	—	—	—	—	—	—	—	—	—	—	—	—	—	—	—
PLL_2_C4	—	—	✓	—	✓	—	—	—	—	—	—	—	—	—	—	—	—	—	—	—
PLL_3_C0	—	—	—	—	—	✓	—	—	—	—	—	—	—	—	—	—	—	—	—	✓

**Table 5-1. GCLK Network Connections for EP4CGX15, EP4CGX22, and EP4CGX30 <sup>(1)</sup>, <sup>(2)</sup> (Part 2 of 2)**

GCLK Network Clock Sources	GCLK Networks																			
	0	1	2	3	4	5	6	7	8	9	10	11	12	13	14	15	16	17	18	19
PLL_3_C1	—	—	—	—	—	—	✓	—	—	✓	—	—	—	—	—	—	✓	—	—	✓
PLL_3_C2	—	—	—	—	—	✓	—	✓	—	—	—	—	—	—	—	✓	—	✓	—	—
PLL_3_C3	—	—	—	—	—	—	✓	—	✓	—	—	—	—	—	—	—	✓	—	✓	—
PLL_3_C4	—	—	—	—	—	—	—	✓	—	✓	—	—	—	—	—	—	—	✓	—	✓
PLL_4_C0 <sup>(3)</sup>	—	—	—	—	—	✓	—	—	✓	—	✓	—	—	✓	—	—	—	—	—	—
PLL_4_C1 <sup>(3)</sup>	—	—	—	—	—	—	✓	—	—	✓	—	✓	—	—	✓	—	—	—	—	—
PLL_4_C2 <sup>(3)</sup>	—	—	—	—	—	✓	—	✓	—	—	✓	—	✓	—	—	—	—	—	—	—
PLL_4_C3 <sup>(3)</sup>	—	—	—	—	—	—	✓	—	✓	—	—	✓	—	✓	—	—	—	—	—	—
PLL_4_C4 <sup>(3)</sup>	—	—	—	—	—	—	—	✓	—	✓	—	—	✓	—	✓	—	—	—	—	—
DPCLK2	—	—	—	—	—	—	—	—	—	—	—	—	—	—	—	—	✓	—	—	—
DPCLK3 <sup>(4)</sup>	—	—	—	—	—	—	—	—	—	—	—	—	—	—	—	—	—	—	✓	—
DPCLK4 <sup>(4)</sup>	—	—	—	—	—	—	—	—	—	—	—	—	—	—	—	—	—	✓	—	—
DPCLK5	—	—	—	—	—	—	—	—	—	—	—	—	—	—	—	—	—	—	—	✓
DPCLK6 <sup>(4)</sup>	—	—	—	—	—	—	—	—	✓	—	—	—	—	—	—	—	—	—	—	—
DPCLK7	—	—	—	—	—	—	✓	—	—	—	—	—	—	—	—	—	—	—	—	—
DPCLK8	—	—	—	—	—	—	—	—	—	✓	—	—	—	—	—	—	—	—	—	—
DPCLK9 <sup>(4)</sup>	—	—	—	—	—	—	—	✓	—	—	—	—	—	—	—	—	—	—	—	—
DPCLK10	—	—	—	—	—	—	—	—	—	—	—	—	—	—	—	✓	—	—	—	—
DPCLK11 <sup>(4)</sup>	—	—	—	—	—	—	—	—	—	—	—	—	—	✓	—	—	—	—	—	—
DPCLK12 <sup>(4)</sup>	—	—	—	—	—	—	—	—	—	—	—	—	—	—	✓	—	—	—	—	—
DPCLK13	—	—	—	—	—	—	—	—	—	—	—	✓	—	—	—	—	—	—	—	—

**Notes to Table 5-1:**

- (1) EP4CGX30 information in this table refers to all EP4CGX30 packages except F484 package.
- (2) PLL\_1 and PLL\_2 are multipurpose PLLs while PLL\_3 and PLL\_4 are general purpose PLLs.
- (3) PLL\_4 is only available in EP4CGX22 and EP4CGX30 devices in F324 package.
- (4) This pin applies to EP4CGX22 and EP4CGX30 devices.

**Table 5-2. GCLK Network Connections for EP4CGX30, EP4CGX50, EP4CGX75, EP4CGX110, and EP4CGX150 Devices (1), (2) (Part 1 of 4)**

GCLK Network Clock Sources	GCLK Networks																								
	0	1	2	3	4	5	6	7	8	9	10	11	12	13	14	15	16	17	18	19	20	21	22	23	
CLKIO4/DIFFCLK_2n	—	—	—	—	—	—	—	—	—	—	—	—	✓	—	✓	—	✓	—	—	—	—	—	—	—	—
CLKIO5/DIFFCLK_2p	—	—	—	—	—	—	—	—	—	—	—	—	—	✓	✓	—	—	✓	—	—	—	—	—	—	—
CLKIO6/DIFFCLK_3n	—	—	—	—	—	—	—	—	—	—	—	—	—	✓	—	✓	—	—	—	—	—	—	—	—	—
CLKIO7/DIFFCLK_3p	—	—	—	—	—	—	—	—	—	—	—	—	✓	—	—	✓	—	—	—	—	—	—	—	—	—
CLKIO8/DIFFCLK_5n	—	—	—	—	—	—	—	—	—	—	—	—	—	—	—	—	—	—	✓	—	—	—	—	—	—
CLKIO9/DIFFCLK_5p	—	—	—	—	—	—	—	—	—	—	—	—	—	—	—	—	—	—	—	✓	—	—	—	—	—
CLKIO10/DIFFCLK_4n/RE FCLK3n	—	—	—	—	—	—	—	—	—	—	—	—	—	—	—	—	—	—	—	—	✓	—	—	—	—
CLKIO11/DIFFCLK_4p/RE FCLK3p	—	—	—	—	—	—	—	—	—	—	—	—	—	—	—	—	—	—	—	—	—	✓	—	—	—
CLKIO12/DIFFCLK_7p/RE FCLK2p	—	—	—	—	—	—	—	—	—	—	—	—	—	—	—	—	—	—	—	—	—	—	—	—	—
CLKIO13/DIFFCLK_7n/RE FCLK2n	—	—	—	—	—	—	—	—	—	—	—	—	—	—	—	—	—	—	—	—	—	—	—	—	—
CLKIO14/DIFFCLK_6p	—	—	—	—	—	—	—	—	—	—	—	—	—	—	—	—	—	—	—	—	—	—	—	—	—
CLKIO15/DIFFCLK_6n	—	—	—	—	—	—	—	—	—	—	—	—	—	—	—	—	—	—	—	—	—	—	—	—	—
PLL_1_C0	✓	—	—	—	—	—	—	—	—	—	—	—	—	—	—	—	—	—	—	—	—	—	—	—	—
PLL_1_C1	—	—	—	—	—	—	—	—	—	—	—	—	—	—	—	—	—	—	—	—	—	—	—	—	—
PLL_1_C2	—	—	—	—	—	—	—	—	—	—	—	—	—	—	—	—	—	—	—	—	—	—	—	—	—
PLL_1_C3	—	—	—	—	—	—	—	—	—	—	—	—	—	—	—	—	—	—	—	—	—	—	—	—	—
PLL_1_C4	—	—	—	—	—	—	—	—	—	—	—	—	—	—	—	—	—	—	—	—	—	—	—	—	—
PLL_2_C0	—	—	—	—	—	—	—	—	—	—	—	—	—	—	—	—	—	—	—	—	—	—	—	—	—
PLL_2_C1	—	—	—	—	—	—	—	—	—	—	—	—	—	—	—	—	—	—	—	—	—	—	—	—	—
PLL_2_C2	—	—	—	—	—	—	—	—	—	—	—	—	—	—	—	—	—	—	—	—	—	—	—	—	—
PLL_2_C3	—	—	—	—	—	—	—	—	—	—	—	—	—	—	—	—	—	—	—	—	—	—	—	—	—
PLL_2_C4	—	—	—	—	—	—	—	—	—	—	—	—	—	—	—	—	—	—	—	—	—	—	—	—	—

**Table 5-2. GCLK Network Connections for EP4CGX30, EP4CGX50, EP4CGX75, EP4CGX10, and EP4CGX150 Devices <sup>(1)</sup>, <sup>(2)</sup> (Part 2 of 4)**

GCLK Network Clock Sources	GCLK Networks																							
	0	1	2	3	4	5	6	7	8	9	10	11	12	13	14	15	16	17	18	19	20	21	22	23
PLL_3_C0	—	—	—	—	—	—	—	—	—	—	—	—	✓	—	—	✓	—	—	—	—	—	—	—	—
PLL_3_C1	—	—	—	—	—	—	—	—	—	—	—	—	—	✓	—	—	✓	—	—	—	—	—	—	—
PLL_3_C2	—	—	—	—	—	—	—	—	—	—	—	✓	—	—	—	—	—	—	—	—	—	—	—	—
PLL_3_C3	—	—	—	—	—	—	—	—	—	—	—	—	—	✓	—	—	—	—	—	—	—	—	—	—
PLL_3_C4	—	—	—	—	—	—	—	—	—	—	—	—	—	—	—	—	—	—	—	—	—	—	—	—
PLL_4_C0	—	—	—	—	—	—	—	—	—	—	—	—	—	—	—	—	—	—	—	—	—	—	—	—
PLL_4_C1	—	—	—	—	—	—	—	—	—	—	—	—	—	✓	—	—	—	—	—	—	—	—	—	—
PLL_4_C2	—	—	—	—	—	—	—	—	—	—	—	—	—	—	—	—	—	—	—	—	—	—	—	—
PLL_4_C3	—	—	—	—	—	—	—	—	—	—	—	—	—	—	—	—	—	—	—	—	—	—	—	—
PLL_4_C4	—	—	—	—	—	—	—	—	—	—	—	—	—	—	—	—	—	—	—	—	—	—	—	—
PLL_5_C0	—	—	—	—	—	—	—	—	—	—	—	—	—	—	—	—	—	—	—	—	—	—	—	—
PLL_5_C1	—	—	—	—	—	—	—	—	—	—	—	—	—	—	—	—	—	—	—	—	—	—	—	—
PLL_5_C2	—	—	—	—	—	—	—	—	—	—	—	—	—	—	—	—	—	—	—	—	—	—	—	—
PLL_5_C3	—	—	—	—	—	—	—	—	—	—	—	—	—	—	—	—	—	—	—	—	—	—	—	—
PLL_5_C4	—	—	—	—	—	—	—	—	—	—	—	—	—	—	—	—	—	—	—	—	—	—	—	—
PLL_6_C0	—	—	—	—	—	—	—	—	—	—	—	—	—	—	—	—	—	—	—	—	—	—	—	—
PLL_6_C1	—	—	—	—	—	—	—	—	—	—	—	—	—	—	—	—	—	—	—	—	—	—	—	—
PLL_6_C2	—	—	—	—	—	—	—	—	—	—	—	—	—	—	—	—	—	—	—	—	—	—	—	—
PLL_6_C3	—	—	—	—	—	—	—	—	—	—	—	—	—	—	—	—	—	—	—	—	—	—	—	—
PLL_6_C4	—	—	—	—	—	—	—	—	—	—	—	—	—	—	—	—	—	—	—	—	—	—	—	—
PLL_7_C0 <sup>(3)</sup>	—	—	—	—	—	—	—	—	—	—	—	—	—	—	—	—	—	—	—	—	—	—	—	—
PLL_7_C1 <sup>(3)</sup>	—	—	—	—	—	—	—	—	—	—	—	—	—	—	—	—	—	—	—	—	—	—	—	—
PLL_7_C2 <sup>(3)</sup>	—	—	—	—	—	—	—	—	—	—	—	—	—	—	—	—	—	—	—	—	—	—	—	—
PLL_7_C3 <sup>(3)</sup>	—	—	—	—	—	—	—	—	—	—	—	—	—	—	—	—	—	—	—	—	—	—	—	—
PLL_7_C4 <sup>(3)</sup>	—	—	—	—	—	—	—	—	—	—	—	—	—	—	—	—	—	—	—	—	—	—	—	—

**Table 5-2. GCLK Network Connections for EP4CGX30, EP4CGX50, EP4CGX75, EP4CGX110, and EP4CGX150 Devices (1), (2) (Part 3 of 4)**

GCLK Network Clock Sources	GCLK Networks																							
	0	1	2	3	4	5	6	7	8	9	10	11	12	13	14	15	16	17	18	19	20	21	22	23
PLL_8_C0 (3)	—	—	—	—	—	—	✓	—	✓	—	—	—	—	—	—	—	—	—	—	—	—	—	—	—
PLL_8_C1 (3)	—	—	—	—	—	—	—	—	—	—	—	—	—	—	—	—	—	—	—	—	—	—	—	—
PLL_8_C2 (3)	—	—	—	—	—	—	—	—	—	—	—	—	—	—	—	—	—	—	—	—	—	—	—	—
PLL_8_C3 (3)	—	—	—	—	—	—	✓	—	—	✓	—	—	—	—	—	—	—	—	—	—	—	—	—	—
PLL_8_C4 (3)	—	—	—	—	—	—	—	✓	—	—	✓	—	—	—	—	—	—	—	—	—	—	—	—	—
DPCLK0	—	—	—	—	—	—	—	—	—	—	—	—	—	—	—	—	—	—	—	—	—	—	—	—
DPCLK1	—	—	—	—	—	—	—	—	—	—	—	—	—	—	—	—	—	—	—	—	—	—	—	—
DPCLK2	—	—	—	—	—	—	—	—	—	—	—	—	—	—	—	—	—	—	—	—	—	—	—	—
DPCLK3	—	—	—	—	—	—	—	—	—	—	—	—	—	—	—	—	—	—	—	—	—	—	—	—
DPCLK4	—	—	—	—	—	—	—	—	—	—	—	—	—	—	—	—	—	—	—	—	—	—	—	—
DPCLK5	—	—	—	—	—	—	—	—	—	—	—	—	—	—	—	—	—	—	—	—	—	—	—	—
DPCLK6	—	—	—	—	—	—	—	—	—	—	—	—	—	—	—	—	—	—	—	—	—	—	—	—
DPCLK7	—	—	—	—	—	—	—	—	—	—	—	—	—	—	—	—	—	—	—	—	—	—	—	—
DPCLK8	—	—	—	—	—	—	—	—	—	—	—	—	—	—	—	—	—	—	—	—	—	—	—	—
DPCLK9	—	—	—	—	—	—	—	—	—	—	—	—	—	—	—	—	—	—	—	—	—	—	—	—
DPCLK10	—	—	—	—	—	—	—	—	—	—	—	—	—	—	—	—	—	—	—	—	—	—	—	—
DPCLK11	—	—	—	—	—	—	—	—	—	—	—	—	—	—	—	—	—	—	—	—	—	—	—	—
DPCLK12	—	—	—	—	—	—	—	—	—	—	—	—	—	—	—	—	—	—	—	—	—	—	—	—
DPCLK13	—	—	—	—	—	—	—	—	—	—	—	—	—	—	—	—	—	—	—	—	—	—	—	—
DPCLK14	—	—	—	—	—	—	—	—	—	—	—	—	—	—	—	—	—	—	—	—	—	—	—	—
DPCLK15	—	—	—	—	—	—	—	—	—	—	—	—	—	—	—	—	—	—	—	—	—	—	—	—
DPCLK16	—	—	—	—	—	—	—	—	—	—	—	—	—	—	—	—	—	—	—	—	—	—	—	—

**Table 5-2. GCLK Network Connections for EP4CGX30, EP4CGX50, EP4CGX75, EP4CGX10, and EP4CGX150 Devices <sup>(1)</sup>, <sup>(2)</sup> (Part 4 of 4)**

GCLK Network Clock Sources	GCLK Networks																							
	0	1	2	3	4	5	6	7	8	9	10	11	12	13	14	15	16	17	18	19	20	21	22	23
DPCLK17	—	—	—	—	—	—	—	—	—	—	—	—	—	—	—	—	—	—	—	—	—	—	—	—

**Notes to Table 5-2:**

- (1) EP4CGX30 information in this table refers to only EP4CGX30 device in F484 package.
- (2) PLL\_1, PLL\_2, PLL\_3, and PLL\_4 are general purpose PLLs while PLL\_5, PLL\_6, PLL\_7, and PLL\_8 are multipurpose PLLs.
- (3) PLL\_7 and PLL\_8 are not available in EP4CXGX30, EP4CGX50, EP4CGX75, EP4CGX10, and EP4CGX150 devices in F484 package.

**Table 5-3. GCLK Network Connections for Cyclone IV E Devices <sup>(1)</sup> (Part 1 of 3)**

GCLK Network Clock Sources	GCLK Networks																							
	0	1	2	3	4	5	6	7	8	9	10	11	12	13	14	15	16	17	1					
CLK1	—	✓	—	—	—	—	—	—	—	—	—	—	—	—	—	—	—	—	—	—	—	—	—	—
CLK2/DIFFCLK_1p	—	✓	—	✓	—	—	—	—	—	—	—	—	—	—	—	—	—	—	—	—	—	—	—	—
CLK3/DIFFCLK_1n	✓	—	—	✓	—	—	—	—	—	—	—	—	—	—	—	—	—	—	—	—	—	—	—	—
CLK4/DIFFCLK_2p	—	—	—	—	—	✓	—	—	—	—	—	—	—	—	—	—	—	—	—	—	—	—	—	—
CLK5/DIFFCLK_2n	—	—	—	—	—	—	—	—	—	—	—	—	—	—	—	—	—	—	—	—	—	—	—	—
CLK6/DIFFCLK_3p	—	—	—	—	—	—	—	—	—	—	—	—	—	—	—	—	—	—	—	—	—	—	—	—
CLK7/DIFFCLK_3n	—	—	—	—	—	—	—	—	—	—	—	—	—	—	—	—	—	—	—	—	—	—	—	—
CLK8/DIFFCLK_5n <sup>(2)</sup>	—	—	—	—	—	—	—	—	—	—	—	—	—	—	—	—	—	—	—	—	—	—	—	—
CLK9/DIFFCLK_5p <sup>(2)</sup>	—	—	—	—	—	—	—	—	—	—	—	—	—	—	—	—	—	—	—	—	—	—	—	—
CLK10/DIFFCLK_4n <sup>(2)</sup>	—	—	—	—	—	—	—	—	—	—	—	—	—	—	—	—	—	—	—	—	—	—	—	—
CLK11/DIFFCLK_4p <sup>(2)</sup>	—	—	—	—	—	—	—	—	—	—	—	—	—	—	—	—	—	—	—	—	—	—	—	—
CLK12/DIFFCLK_7n <sup>(2)</sup>	—	—	—	—	—	—	—	—	—	—	—	—	—	—	—	—	—	—	—	—	—	—	—	—
CLK13/DIFFCLK_7p <sup>(2)</sup>	—	—	—	—	—	—	—	—	—	—	—	—	—	—	—	—	—	—	—	—	—	—	—	—
CLK14/DIFFCLK_6n <sup>(2)</sup>	—	—	—	—	—	—	—	—	—	—	—	—	—	—	—	—	—	—	—	—	—	—	—	—

**Table 5-3. GCLK Network Connections for Cyclone IV E Devices (1) (Part 2 of 3)**

GCLK Network Clock Sources	GCLK Networks																		
	0	1	2	3	4	5	6	7	8	9	10	11	12	13	14	15	16	17	
CLK15/DIFFCLK_6p (2)	—	—	—	—	—	—	—	—	—	—	—	—	—	—	—	✓	—	—	—
PLL_1_C0 (3)	✓	—	—	✓	—	—	—	—	—	—	—	—	—	—	—	—	—	—	—
PLL_1_C1 (3)	—	✓	—	—	✓	—	—	—	—	—	—	—	—	—	—	—	—	—	—
PLL_1_C2 (3)	✓	—	✓	—	—	—	—	—	—	—	—	—	—	—	—	—	—	—	—
PLL_1_C3 (3)	—	✓	—	✓	—	—	—	—	—	—	—	—	—	—	—	—	—	—	—
PLL_1_C4 (3)	—	—	✓	—	✓	—	—	—	—	—	—	—	—	—	—	—	—	—	—
PLL_2_C0 (3)	—	—	—	—	—	✓	—	—	—	—	—	—	—	—	—	—	—	—	—
PLL_2_C1 (3)	—	—	—	—	—	✓	—	—	—	—	—	—	—	—	—	—	—	—	—
PLL_2_C2 (3)	—	—	—	—	—	✓	—	—	—	—	—	—	—	—	—	—	—	—	—
PLL_2_C3 (3)	—	—	—	—	—	—	✓	—	—	—	—	—	—	—	—	—	—	—	—
PLL_2_C4 (3)	—	—	—	—	—	—	—	✓	—	—	—	—	—	—	—	—	—	—	—
PLL_3_C0	—	—	—	—	—	—	—	—	—	—	—	—	—	—	—	—	—	—	—
PLL_3_C1	—	—	—	—	—	—	—	—	—	—	—	—	—	—	—	—	—	—	—
PLL_3_C2	—	—	—	—	—	—	—	—	—	—	—	—	—	—	—	—	—	—	—
PLL_3_C3	—	—	—	—	—	—	—	—	—	—	—	—	—	—	—	—	—	—	—
PLL_3_C4	—	—	—	—	—	—	—	—	—	—	—	—	—	—	—	—	—	—	—
PLL_4_C0	—	—	—	—	—	—	—	—	—	—	—	—	—	—	—	—	—	—	—
PLL_4_C1	—	—	—	—	—	—	—	—	—	—	—	—	—	—	—	—	—	—	—
PLL_4_C2	—	—	—	—	—	—	—	—	—	—	—	—	—	—	—	—	—	—	—
PLL_4_C3	—	—	—	—	—	—	—	—	—	—	—	—	—	—	—	—	—	—	—
PLL_4_C4	—	—	—	—	—	—	—	—	—	—	—	—	—	—	—	—	—	—	—
DFCLK0	✓	—	—	—	—	—	—	—	—	—	—	—	—	—	—	—	—	—	—
DFCLK1	—	—	—	—	—	—	—	—	—	—	—	—	—	—	—	—	—	—	—
DFCLK7 (4)	—	—	—	—	—	—	—	—	—	—	—	—	—	—	—	—	—	—	—
CDPCLK0, or CDPCLK7 (2), (5)	—	—	✓	—	—	—	—	—	—	—	—	—	—	—	—	—	—	—	—

**Table 5-3. GCLK Network Connections for Cyclone IV E Devices (1) (Part 3 of 3)**

GCLK Network Clock Sources	GCLK Networks																	
	0	1	2	3	4	5	6	7	8	9	10	11	12	13	14	15	16	17
DPCLK2 (4)	—	—	—	—	—	—	—	—	—	—	—	—	—	—	—	—	—	—
CDPCLK1, or CDPCLK2 (2), (5)	—	—	—	✓	—	—	—	—	—	—	—	—	—	—	—	—	—	—
DPCLK5 (4)	—	—	—	—	—	—	—	—	—	—	—	—	—	—	—	—	—	—
DPCLK7 (2)	—	—	—	—	—	—	—	—	—	—	—	—	—	—	—	—	—	—
DPCLK4 (4)	—	—	—	—	—	—	—	—	—	—	—	—	—	—	—	—	—	—
DPCLK6 (2)	—	—	—	—	—	—	—	—	—	—	—	—	—	—	—	—	—	—
DPCLK6 (4)	—	—	—	—	—	—	—	—	—	—	—	—	—	—	—	—	—	—
CDPCLK5, or CDPCLK6 (2), (5)	—	—	—	—	—	—	—	—	—	—	—	—	—	—	—	—	—	—
DPCLK3 (4)	—	—	—	—	—	—	—	—	—	—	—	—	—	—	—	—	—	—
CDPCLK4, or CDPCLK3 (2), (5)	—	—	—	—	—	—	—	—	—	—	—	—	—	—	—	—	—	—
DPCLK8	—	—	—	—	—	—	—	—	—	—	—	—	—	—	—	—	—	—
DPCLK11	—	—	—	—	—	—	—	—	—	—	—	—	—	—	—	—	—	—
DPCLK9	—	—	—	—	—	—	—	—	—	—	—	—	—	—	—	—	—	—
DPCLK10	—	—	—	—	—	—	—	—	—	—	—	—	—	—	—	—	—	—
DPCLK5	—	—	—	—	—	—	—	—	—	—	—	—	—	—	—	—	—	—
DPCLK2	—	—	—	—	—	—	—	—	—	—	—	—	—	—	—	—	—	—
DPCLK4	—	—	—	—	—	—	—	—	—	—	—	—	—	—	—	—	—	—
DPCLK3	—	—	—	—	—	—	—	—	—	—	—	—	—	—	—	—	—	—

**Notes to Table 5-3:**

- (1) EP4CE6 and EP4CE10 devices only have GCLK networks 0 to 9.
- (2) These pins apply to all Cyclone IV E devices except EP4CE6 and EP4CE10 devices.
- (3) EP4CE6 and EP4CE10 devices only have PLL\_1 and PLL\_2.
- (4) This pin applies only to EP4CE6 and EP4CE10 devices.
- (5) Only one of the two CDPCLK pins can feed the clock control block. You can use the other pin as a regular I/O pin.

If you do not use dedicated clock pins to feed the GCLKs, you can use them as general-purpose input pins to feed the logic array. However, when using them as general-purpose input pins, they do not have support for an I/O register and must use LE-based registers in place of an I/O register.

 For more information about how to connect the clock and PLL pins, refer to the *Cyclone IV Device Family Pin Connection Guidelines*.

## Clock Control Block

The clock control block drives the GCLKs. Clock control blocks are located on each side of the device, close to the dedicated clock input pins. GCLKs are optimized for minimum clock skew and delay.

Table 5-4 lists the sources that can feed the clock control block, which in turn feeds the GCLKs.

**Table 5-4. Clock Control Block Inputs**

Input	Description
Dedicated clock inputs	Dedicated clock input pins can drive clocks or global signals, such as synchronous and asynchronous clears, presets, or clock enables onto given GCLKs.
Dual-purpose clock (DPCLK and CDPCLK) I/O input	DPCLK and CDPCLK I/O pins are bidirectional dual function pins that are used for high fan-out control signals, such as protocol signals, TRDY and IRDY signals for PCI, via the GCLK. Clock control blocks that have inputs driven by dual-purpose clock I/O pins are not able to drive PLL inputs.
PLL outputs	PLL counter outputs can drive the GCLK.
Internal logic	You can drive the GCLK through logic array routing to enable internal logic elements (LEs) to drive a high fan-out, low-skew signal path. Clock control blocks that have inputs driven by internal logic are not able to drive PLL inputs.

In Cyclone IV devices, dedicated clock input pins, PLL counter outputs, dual-purpose clock I/O inputs, and internal logic can all feed the clock control block for each GCLK. The output from the clock control block in turn feeds the corresponding GCLK. The GCLK can drive the PLL input if the clock control block inputs are outputs of another PLL or dedicated clock input pins. There are five or six clock control blocks on each side of the device periphery—depending on device density; providing up to 30 clock control blocks in each Cyclone IV GX device. The maximum number of clock control blocks per Cyclone IV E device is 20. For the clock control block locations, refer to [Figure 5-2 on page 5-12](#), [Figure 5-3 on page 5-13](#), and [Figure 5-4 on page 5-14](#).

 The clock control blocks on the left side of the Cyclone IV GX device do not support any clock inputs.

The control block has two functions:

- Dynamic GCLK clock source selection (not applicable for DPCLK, CDPCLK, and internal logic input)
- GCLK network power down (dynamic enable and disable)

Figure 5-1 shows the clock control block.

Figure 5-1. Clock Control Block

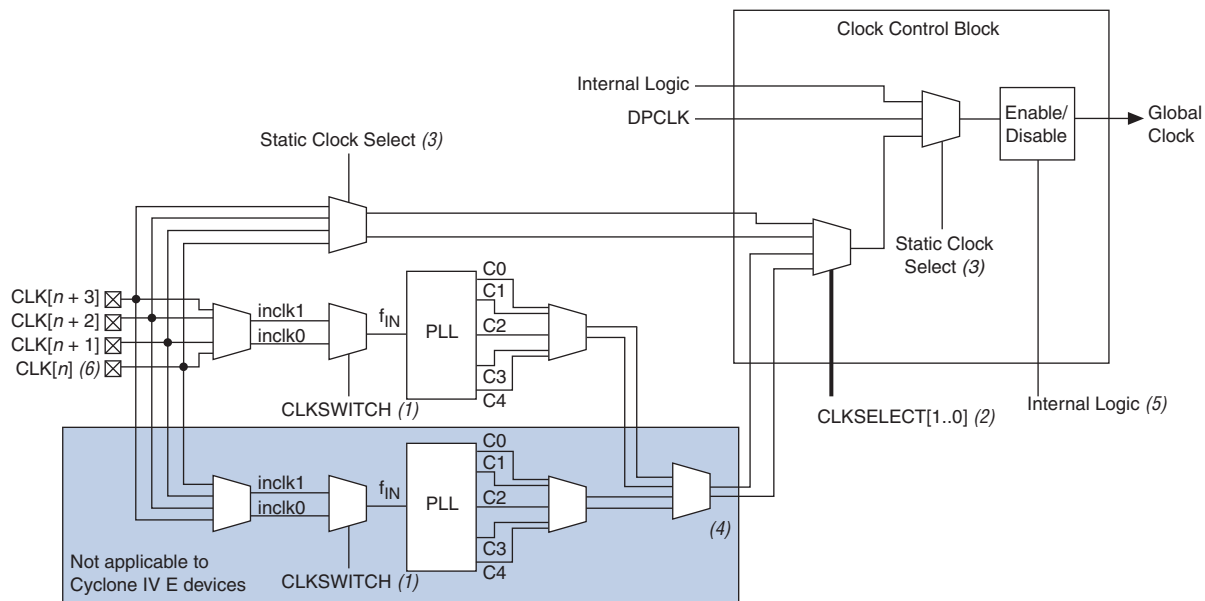

Notes to Figure 5-1:

- (1) The `clkswitch` signal can either be set through the configuration file or dynamically set when using the manual PLL switchover feature. The output of the multiplexer is the input clock ( $f_{IN}$ ) for the PLL.
- (2) The `clkselect[1..0]` signals are fed by internal logic and are used to dynamically select the clock source for the GCLK when the device is in user mode.
- (3) The static clock select signals are set in the configuration file. Therefore, dynamic control when the device is in user mode is not feasible.
- (4) Two out of four PLL clock outputs are selected from adjacent PLLs to drive into the clock control block.
- (5) You can use internal logic to enable or disable the GCLK in user mode.
- (6) `CLK[n]` is not available on the left side of Cyclone IV E devices.

Each PLL generates five clock outputs through the `c[4..0]` counters. Two of these clocks can drive the GCLK through a clock control block, as shown in Figure 5-1.

 For more information about how to use the clock control block in the Quartus II software, refer to the *ALTCLKCTRL Megafunction User Guide*.

## GCLK Network Clock Source Generation

Figure 5-2, Figure 5-3, and Figure 5-4 on page 5-14 show the Cyclone IV PLLs, clock inputs, and clock control block location for different Cyclone IV device densities.

**Figure 5-2. Clock Networks and Clock Control Block Locations in EP4CGX15, EP4CGX22, and EP4CGX30 Devices (1), (2)**

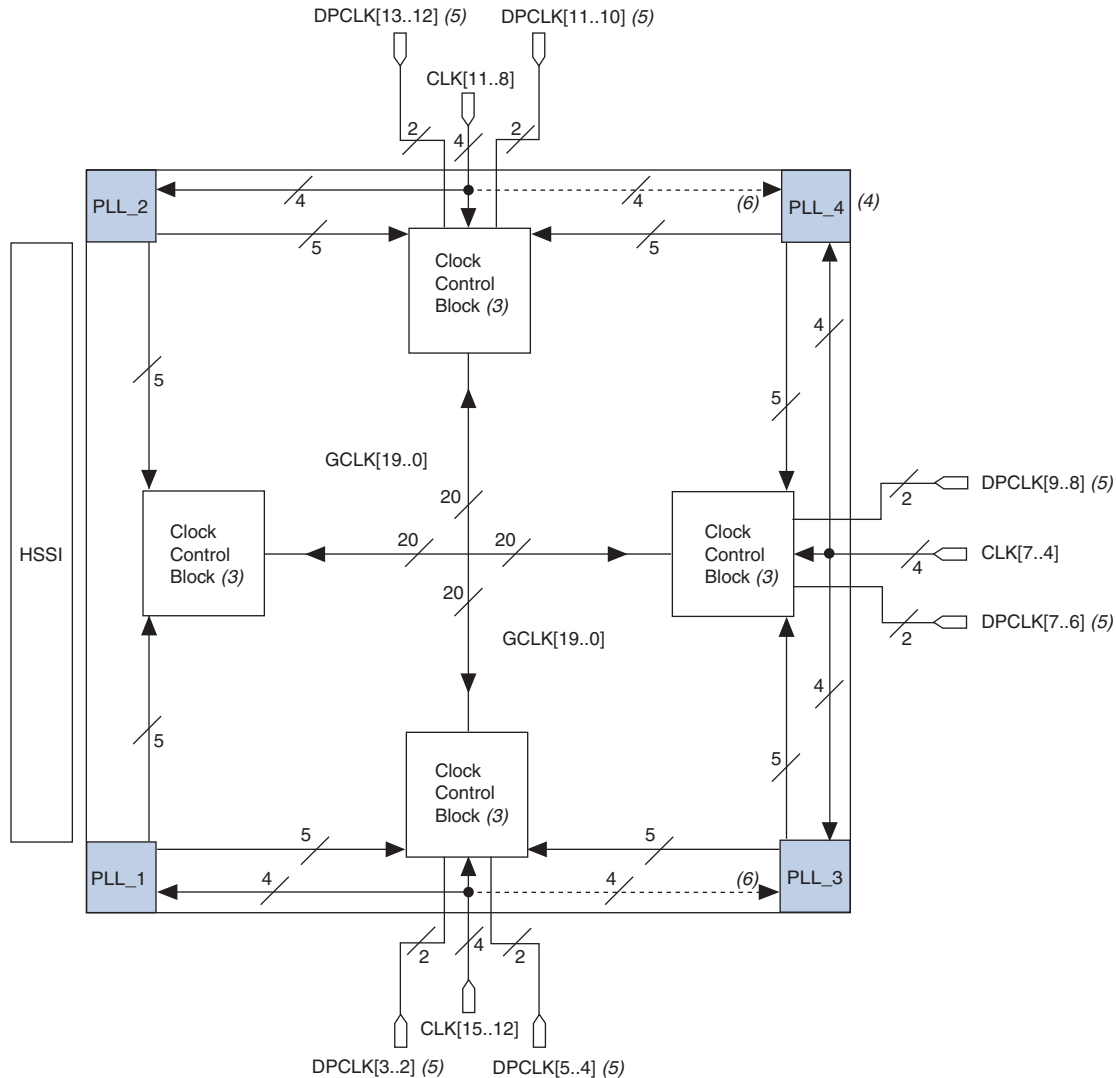

### Notes to Figure 5-2:

- (1) The clock networks and clock control block locations apply to all EP4CGX15, EP4CGX22, and EP4CGX30 devices except EP4CGX30 device in F484 package.
- (2) PLL\_1 and PLL\_2 are multipurpose PLLs while PLL\_3 and PLL\_4 are general purpose PLLs.
- (3) There are five clock control blocks on each side.
- (4) PLL\_4 is only available in EP4CGX22 and EP4CGX30 devices in F324 package.
- (5) The EP4CGX15 device has two DPCLK pins on three sides of the device: DPCLK2 and DPCLK5 on bottom side, DPCLK7 and DPCLK8 on the right side, DPCLK10 and DPCLK13 on the top side of device.
- (6) Dedicated clock pins can feed into this PLL. However, these paths are not fully compensated.

**Figure 5-3. Clock Networks and Clock Control Block Locations in EP4CGX30, EP4CGX50, EP4CGX75, EP4CGX110, and EP4CGX150 Devices (1), (2)**

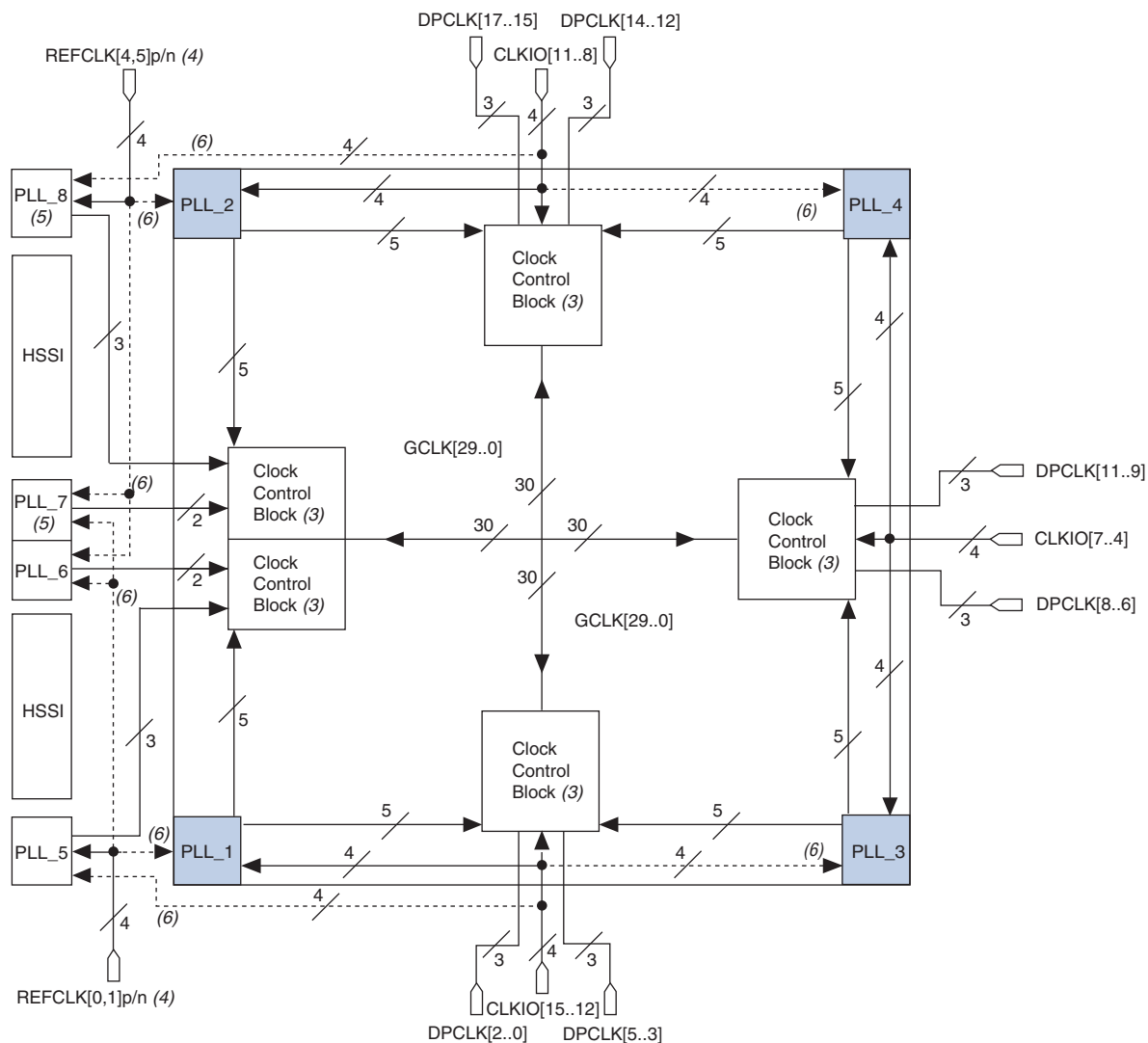

**Notes to Figure 5-3:**

- (1) The clock networks and clock control block locations in this figure apply to only the EP4CGX30 device in F484 package and all EP4CGX50, EP4CGX75, EP4CGX110, and EP4CGX150 devices.
- (2) PLL\_1, PLL\_2, PLL\_3, and PLL\_4 are general purpose PLLs while PLL\_5, PLL\_6, PLL\_7, and PLL\_8 are multipurpose PLLs.
- (3) There are 6 clock control blocks on the top, right and bottom sides of the device and 12 clock control blocks on the left side of the device.
- (4) REFCLK[0, 1]p/n and REFCLK[4, 5]p/n can only drive the general purpose PLLs and multipurpose PLLs on the left side of the device. These clock pins do not have access to the clock control blocks and GCLK networks. The REFCLK[4, 5]p/n pins are not available in devices in F484 package.
- (5) Not available for EP4CGX30, EP4CGX50, EP4CGX75, EP4CGX110, and EP4CGX150 devices in F484 package.
- (6) Dedicated clock pins can feed into this PLL. However, these paths are not fully compensated.

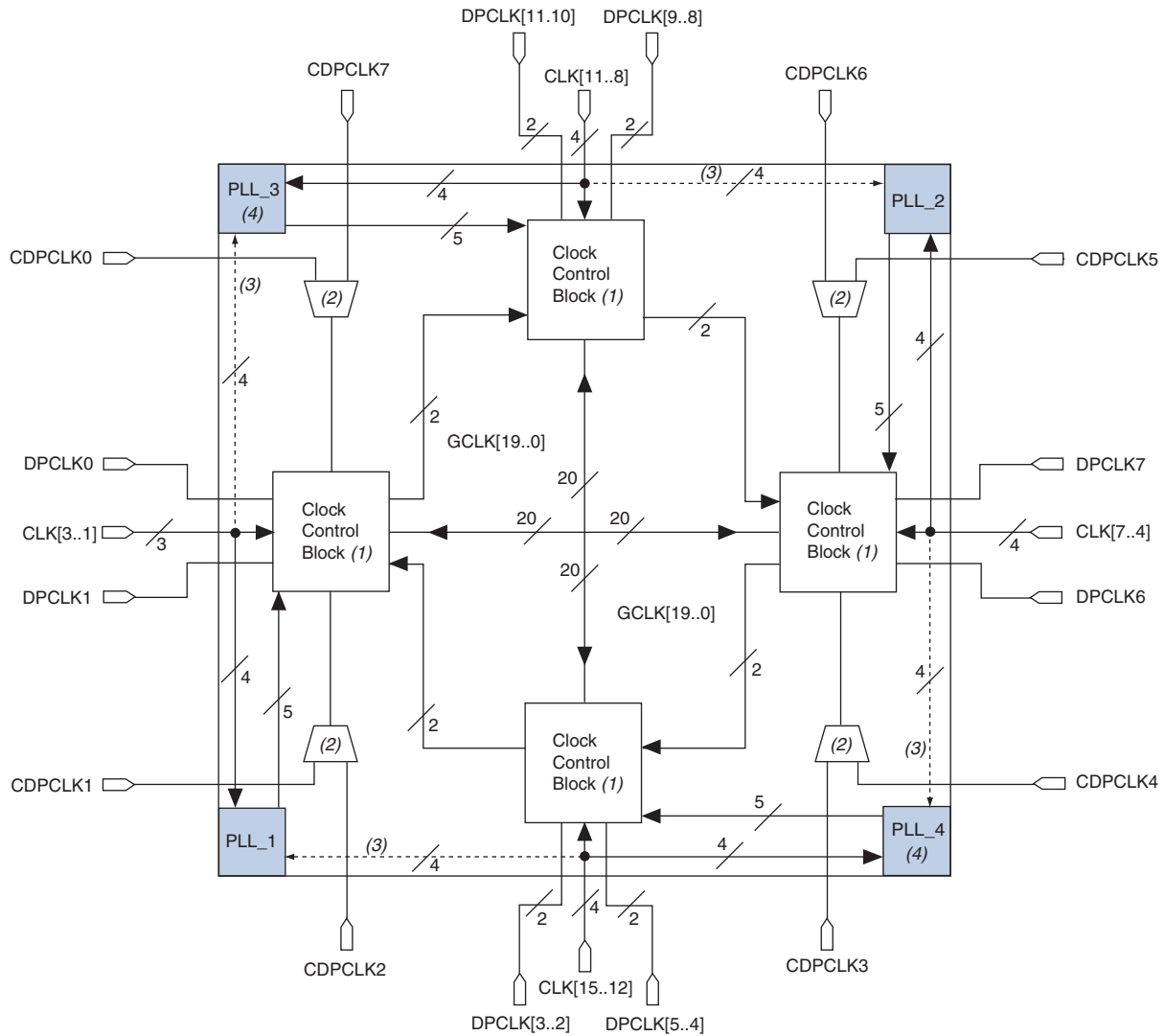
**Figure 5-4. Clock Networks and Clock Control Block Locations in Cyclone IV E Devices****Notes to Figure 5-4:**

- (1) There are five clock control blocks on each side.
- (2) Only one of the corner CDPCLK pins in each corner can feed the clock control block at a time. You can use the other CDPCLK pins as general-purpose I/O (GPIO) pins.
- (3) Dedicated clock pins can feed into this PLL. However, these paths are not fully compensated.
- (4) PLL\_3 and PLL\_4 are not available in EP4CE6 and EP4CE10 devices.

The inputs to the clock control blocks on each side of the Cyclone IV GX device must be chosen from among the following clock sources:

- Four clock input pins
- Ten PLL counter outputs (five from each adjacent PLLs)
- Two, four, or six DPCLK pins from the top, bottom, and right sides of the device
- Five signals from internal logic

From the clock sources listed above, only two clock input pins, two out of four PLL clock outputs (two clock outputs from either adjacent PLLs), one DPCLK pin, and one source from internal logic can drive into any given clock control block, as shown in Figure 5-1 on page 5-11.

Out of these six inputs to any clock control block, the two clock input pins and two PLL outputs are dynamically selected to feed a GCLK. The clock control block supports static selection of the signal from internal logic.

Figure 5-5 shows a simplified version of the clock control blocks on each side of the Cyclone IV GX device periphery.

**Figure 5-5. Clock Control Blocks on Each Side of Cyclone IV GX Device**

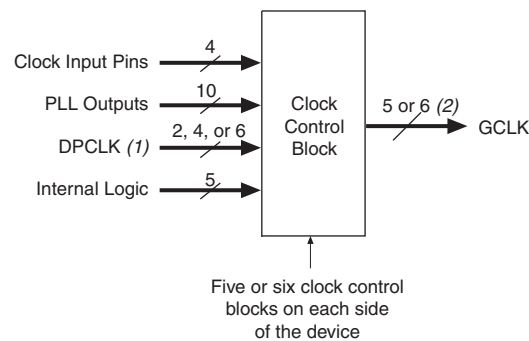

**Notes to Figure 5-5:**

- (1) The EP4CGX15 device has two DPCLK pins; the EP4CGX22 and EP4CGX30 devices have four DPCLK pins; the EP4CGX50, EP4CGX75, EP4CGX110, and EP4CGX150 devices have six DPCLK pins.
- (2) Each clock control block in the EP4CGX15, EP4CGX22, and EP4CGX30 devices can drive five GCLK networks. Each clock control block in the EP4CGX50, EP4CGX75, EP4CGX110, and EP4CGX150 devices can drive six GCLK networks.

The inputs to the five clock control blocks on each side of the Cyclone IV E device must be chosen from among the following clock sources:

- Three or four clock input pins, depending on the specific device
- Five PLL counter outputs
- Two DPCLK pins and two CDPCLK pins from both the left and right sides and four DPCLK pins from both the top and bottom
- Five signals from internal logic

From the clock sources listed above, only two clock input pins, two PLL clock outputs, one DPCLK or CDPCLK pin, and one source from internal logic can drive into any given clock control block, as shown in Figure 5-1 on page 5-11.

Out of these six inputs to any clock control block, the two clock input pins and two PLL outputs are dynamically selected to feed a GCLK. The clock control block supports static selection of the signal from internal logic.

Figure 5-6 shows a simplified version of the five clock control blocks on each side of the Cyclone IV E device periphery.

**Figure 5-6. Clock Control Blocks on Each Side of Cyclone IV E Device <sup>(1)</sup>**

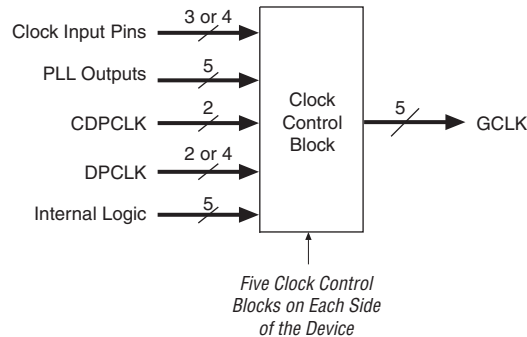

**Note to Figure 5-6:**

(1) The left and right sides of the device have two DPCLK pins; the top and bottom of the device have four DPCLK pins.

## GCLK Network Power Down

You can disable a Cyclone IV device's GCLK (power down) using both static and dynamic approaches. In the static approach, configuration bits are set in the configuration file generated by the Quartus II software, which automatically disables unused GCLKs. The dynamic clock enable or disable feature allows internal logic to control clock enable or disable the GCLKs in Cyclone IV devices.

When a clock network is disabled, all the logic fed by the clock network is in an off-state, thereby reducing the overall power consumption of the device. This function is independent of the PLL and is applied directly on the clock network, as shown in Figure 5-1 on page 5-11.

You can set the input clock sources and the `clkena` signals for the GCLK multiplexers through the Quartus II software using the `ALTCLKCTRL` megafunction.

 For more information, refer to the [ALTCLKCTRL Megafunction User Guide](#).

## clkena Signals

Cyclone IV devices support `clkena` signals at the GCLK network level. This allows you to gate-off the clock even when a PLL is used. Upon re-enabling the output clock, the PLL does not need a resynchronization or re-lock period because the circuit gates off the clock at the clock network level. In addition, the PLL can remain locked independent of the `clkena` signals because the loop-related counters are not affected.

Figure 5-7 shows how to implement the `clkena` signal with a single register.

**Figure 5-7. `clkena` Implementation**

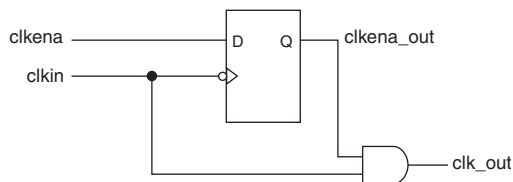

The `clkena` circuitry controlling the output C0 of the PLL to an output pin is implemented with two registers instead of a single register, as shown in Figure 5-7.

Figure 5-8 shows the waveform example for a clock output enable. The `clkena` signal is sampled on the falling edge of the clock (`clkkin`).

This feature is useful for applications that require low power or sleep mode.

**Figure 5-8. `clkena` Implementation: Output Enable**

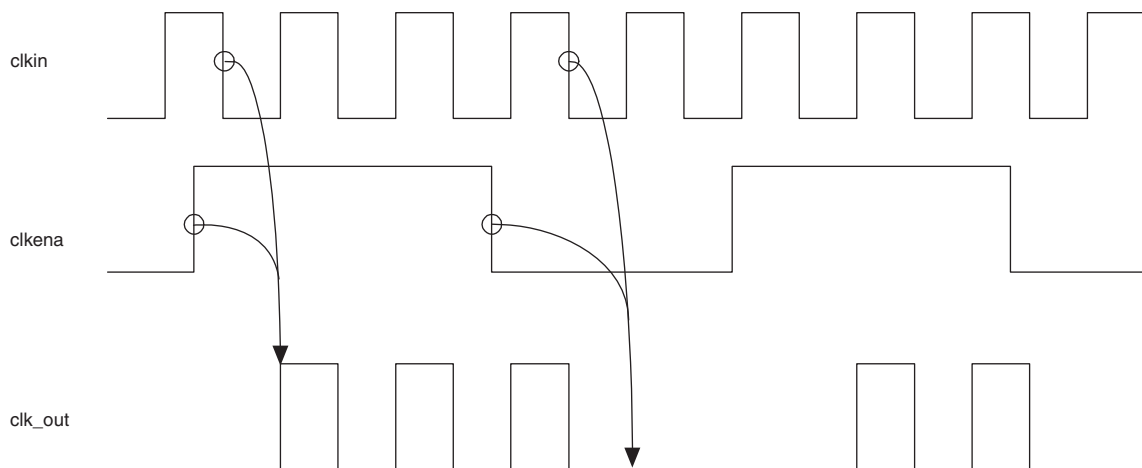

The `clkena` signal can also disable clock outputs if the system is not tolerant to frequency overshoot during PLL resynchronization.

Altera recommends using the `clkena` signals when switching the clock source to the PLLs or the GCLK. The recommended sequence is:

1. Disable the primary output clock by de-asserting the `clkena` signal.
2. Switch to the secondary clock using the dynamic select signals of the clock control block.
3. Allow some clock cycles of the secondary clock to pass before reasserting the `clkena` signal. The exact number of clock cycles you must wait before enabling the secondary clock is design-dependent. You can build custom logic to ensure glitch-free transition when switching between different clock sources.

## PLLs in Cyclone IV Devices

Cyclone IV GX devices offer two variations of PLLs: general purpose PLLs and multipurpose PLLs. Cyclone IV E devices only have the general purpose PLLs.

The general purpose PLLs are used for general-purpose applications in the FPGA fabric and periphery such as external memory interfaces. The multipurpose PLLs are used for clocking the transceiver blocks. When the multipurpose PLLs are not used for transceiver clocking, they can be used for general-purpose clocking.

 For more details about the multipurpose PLLs used for transceiver clocking, refer to the *Cyclone IV Transceivers* chapter.

Cyclone IV GX devices contain up to eight general purpose PLLs and multipurpose PLLs while Cyclone IV E devices have up to four general purpose PLLs that provide robust clock management and synthesis for device clock management, external system clock management, and high-speed I/O interfaces.

 For more information about the number of general purpose PLLs and multipurpose PLLs in each device density, refer to the *Cyclone IV Device Family Overview* chapter.

 The general I/O pins cannot drive the PLL clock input pins.

Table 5-5 lists the features available in Cyclone IV GX PLLs.

**Table 5-5. Cyclone IV GX PLL Features (Part 1 of 2)**

Features	Availability									
	General Purpose PLLs				Multipurpose PLLs					
	PLL_1 (1), (10)	PLL_2 (1), (10)	PLL_3 (2)	PLL_4 (3)	PLL_1 (4)	PLL_2 (4)	PLL_5 (1), (10)	PLL_6 (1), (10)	PLL_7 (1)	PLL_8 (1)
C (output counters)	5									
M, N, C counter sizes	1 to 512 <sup>(5)</sup>									
Dedicated clock outputs	1 single-ended or 1 differential pair									
Clock input pins	12 single-ended or 6 differential pairs <sup>(6)</sup> and 4 differential pairs <sup>(7)</sup>									
Spread-spectrum input clock tracking	✓ <sup>(8)</sup>									
PLL cascading	Through GCLK									
Source-Synchronous Mode	✓	✓	✓	✓	✓	✓	✓	—	—	✓
No Compensation Mode	✓	✓	✓	✓	✓	✓	✓	✓	✓	✓
Normal Mode	✓	✓	✓	✓	✓	✓	✓	—	—	✓
Zero Delay Buffer Mode	✓	✓	✓	✓	✓	✓	✓	—	—	✓
Deterministic Latency Compensation Mode	✓	✓	—	—	✓	✓	✓	✓	✓	✓
Phase shift resolution <sup>(9)</sup>	Down to 96 ps increments									
Programmable duty cycle	✓									
Output counter cascading	✓									

**Table 5-5. Cyclone IV GX PLL Features (Part 2 of 2)**

Features	Availability									
	General Purpose PLLs				Multipurpose PLLs					
	PLL_1 (1), (10)	PLL_2 (1), (10)	PLL_3 (2)	PLL_4 (3)	PLL_1 (4)	PLL_2 (4)	PLL_5 (1), (10)	PLL_6 (1), (10)	PLL_7 (1)	PLL_8 (1)
Input clock switchover					✓					
User mode reconfiguration					✓					
Loss of lock detection					✓					
PLL drives TX Serial Clock, TX Load Enable, and TX Parallel Clock	✓	✓	—	—				✓		
VCO output drives RX clock data recovery (CDR) clock			—					✓		
PLL drives FREF for ppm detect	✓	✓	—	—				✓		

**Notes to Table 5-5:**

- (1) This is only applicable to EP4CGX50, EP4CGX75, EP4CGX110, and EP4CGX150 devices in F672 and F896 package.
- (2) This is applicable to all Cyclone IV devices.
- (3) This is applicable to all Cyclone IV devices except EP4CGX15 devices in all packages, EP4CGX22, and EP4CGX30 devices in F169 package.
- (4) This is only applicable to EP4CGX15, EP4CGX22, and all EP4CGX30 devices except EP4CGX30 in the F484 package.
- (5) C counters range from 1 through 512 if the output clock uses a 50% duty cycle. For any output clocks using a non-50% duty cycle, the post-scale counters range from 1 through 256.
- (6) These clock pins can access the GCLK networks.
- (7) These clock pins are only available in EP4CGX50, EP4CGX75, EP4CGX110, and EP4CGX150 devices and cannot access the GCLK networks. CLK [17, 19, 20, 21]<sub>P</sub> can be used as single-ended clock input pins.
- (8) Only applicable if the input clock jitter is in the input jitter tolerance specifications.
- (9) The smallest phase shift is determined by the voltage-controlled oscillator (VCO) period divided by eight. For degree increments, Cyclone IV GX devices can shift all output frequencies in increments of at least 45°. Smaller degree increments are possible depending on the frequency and divide parameters.
- (10) This is applicable to the EP4CGX30, EP4CGX50, EP4CGX75, EP4CGX110, and EP4CGX150 devices in F484 package.

Table 5-6 lists the features available in Cyclone IV E PLLs.

**Table 5-6. Cyclone IV E PLL Features (Part 1 of 2)**

Hardware Features	Availability
C (output counters)	5
M, N, C counter sizes	1 to 512 (1)
Dedicated clock outputs	1 single-ended or 1 differential pair
Clock input pins	4 single-ended or 2 differential pairs
Spread-spectrum input clock tracking	✓ (2)
PLL cascading	Through GCLK
Compensation modes	Source-Synchronous Mode, No Compensation Mode, Normal Mode, and Zero Delay Buffer Mode
Phase shift resolution	Down to 96-ps increments (3)
Programmable duty cycle	✓
Output counter cascading	✓
Input clock switchover	✓
User mode reconfiguration	✓

**Table 5-6. Cyclone IV E PLL Features (Part 2 of 2)**

Hardware Features	Availability
Loss of lock detection	✓

**Notes to Table 5-6:**

- (1) C counters range from 1 through 512 if the output clock uses a 50% duty cycle. For any output clocks using a non-50% duty cycle, the post-scale counters range from 1 through 256.
- (2) Only applicable if the input clock jitter is in the input jitter tolerance specifications.
- (3) The smallest phase shift is determined by the VCO period divided by eight. For degree increments, Cyclone IV E devices can shift all output frequencies in increments of at least 45°. Smaller degree increments are possible depending on the frequency and divide parameters.

## Cyclone IV PLL Hardware Overview

This section gives a hardware overview of the Cyclone IV PLL.

Figure 5-9 shows a simplified block diagram of the major components of the PLL of Cyclone IV GX devices.

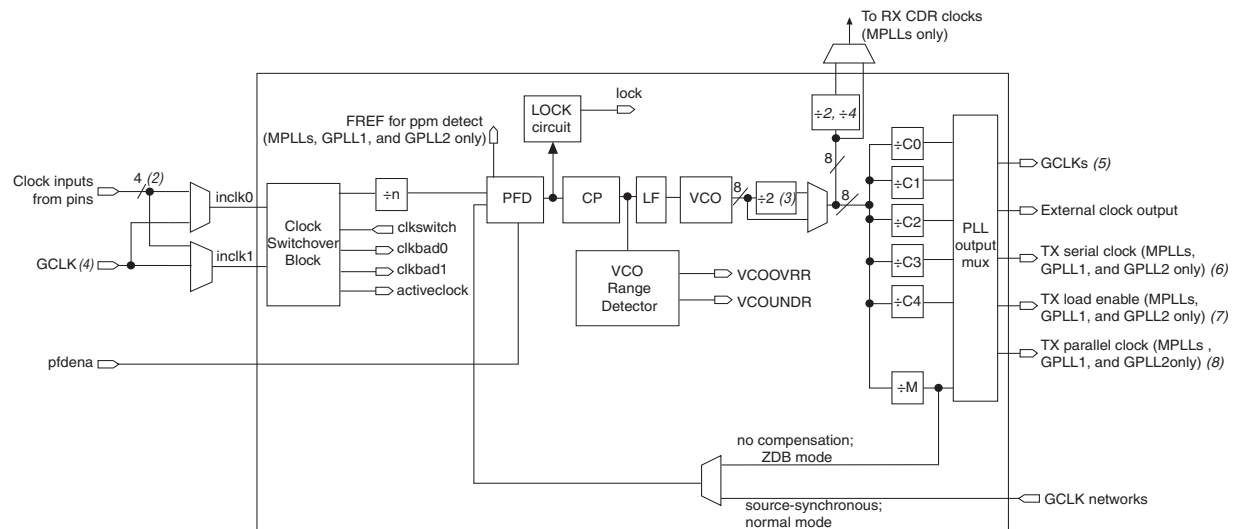
**Figure 5-9. Cyclone IV GX PLL Block Diagram (1)****Notes to Figure 5-9:**

- (1) Each clock source can come from any of the four clock pins located on the same side of the device as the PLL.
- (2) There are additional 4 pairs of dedicated differential clock inputs in EP4CGX50, EP4CGX75, EP4CGX110, and EP4CGX150 devices that can only drive general purpose PLLs and multipurpose PLLs on the left side of the device. CLK [19..16] can access PLL\_2, PLL\_6, PLL\_7, and PLL\_8 while CLK [23..20] can access PLL\_1, PLL\_5, PLL\_6, and PLL\_7. For the location of these clock input pins, refer to Figure 5-3 on page 5-13.
- (3) This is the VCO post-scale counter K.
- (4) This input port is fed by a pin-driven dedicated GCLK, or through a clock control block if the clock control block is fed by an output from another PLL or a pin-driven dedicated GCLK. An internally generated global signal cannot drive the PLL.
- (5) For the general purpose PLL and multipurpose PLL counter outputs connectivity to the GCLKs, refer to Table 5-1 on page 5-2 and Table 5-2 on page 5-4.
- (6) Only the C1 output counter can drive the TX serial clock.
- (7) Only the C2 output counter can drive the TX load enable.
- (8) Only the C3 output counter can drive the TX parallel clock.

Figure 5-10 shows a simplified block diagram of the major components of the PLL of Cyclone IV E devices.

Figure 5-10. Cyclone IV E PLL Block Diagram (1)

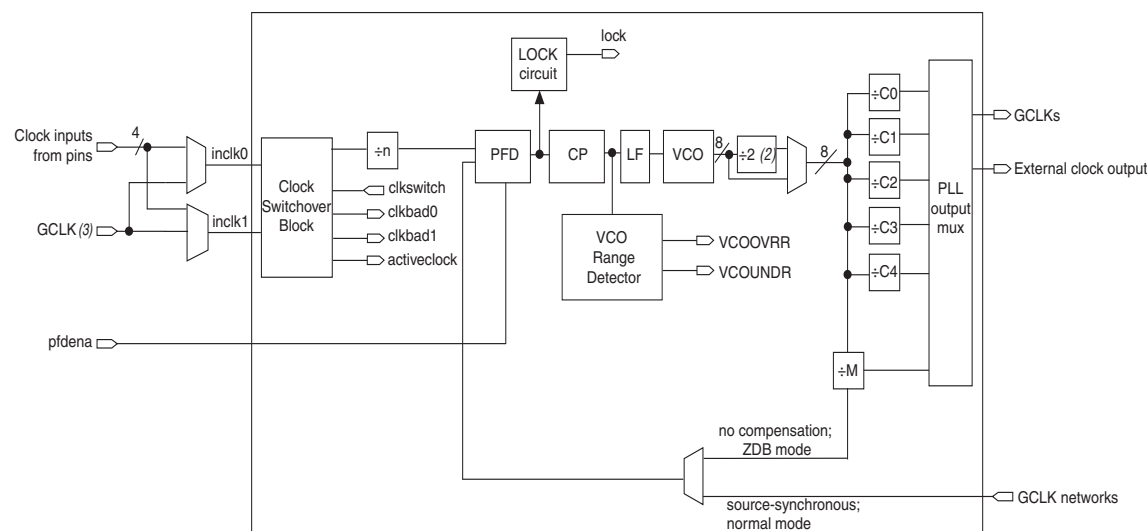

**Notes to Figure 5-10:**

- (1) Each clock source can come from any of the four clock pins located on the same side of the device as the PLL.
- (2) This is the VCO post-scale counter K.
- (3) This input port is fed by a pin-driven dedicated GCLK, or through a clock control block if the clock control block is fed by an output from another PLL or a pin-driven dedicated GCLK. An internally generated global signal cannot drive the PLL.

 The VCO post-scale counter K is used to divide the supported VCO range by two. The VCO frequency reported by the Quartus II software in the PLL summary section of the compilation report takes into consideration the VCO post-scale counter value. Therefore, if the VCO post-scale counter has a value of 2, the frequency reported is lower than the  $f_{VCO}$  specification specified in the *Cyclone IV Device Datasheet* chapter.

## External Clock Outputs

Each PLL of Cyclone IV devices supports one single-ended clock output or one differential clock output. Only the C0 output counter can feed the dedicated external clock outputs, as shown in Figure 5-11, without going through the GCLK. Other output counters can feed other I/O pins through the GCLK.

Figure 5-11 shows the external clock outputs for PLLs.

**Figure 5-11. External Clock Outputs for PLLs**

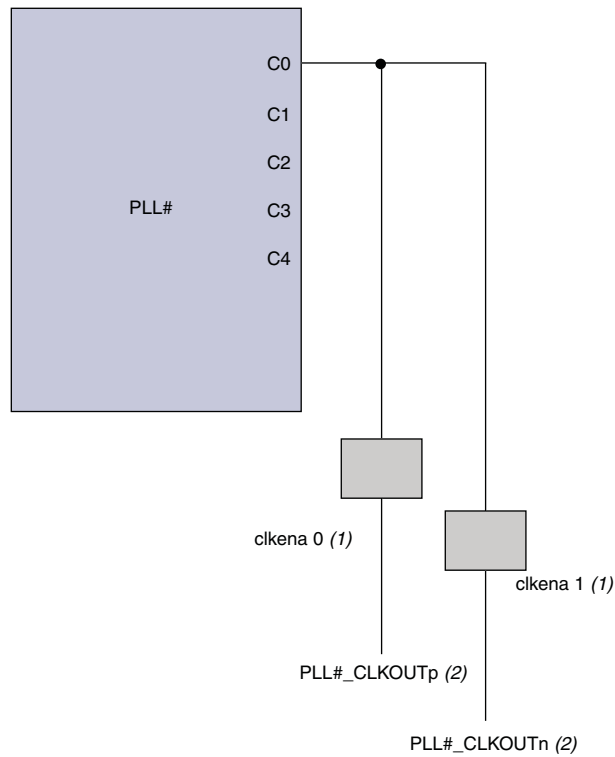

**Notes to Figure 5-11:**

- (1) These external clock enable signals are available only when using the ALTCLKCTRL megafunction.
- (2) `PLL#_CLKOUTp` and `PLL#_CLKOUTn` pins are dual-purpose I/O pins that you can use as one single-ended clock output or one differential clock output. When using both pins as single-ended I/Os, one of them can be the clock output while the other pin is configured as a regular user I/O.

Each pin of a differential output pair is 180° out of phase. The Quartus II software places the NOT gate in your design into the I/O element to implement 180° phase with respect to the other pin in the pair. The clock output pin pairs support the same I/O standards as standard output pins.

 To determine which I/O standards are supported by the PLL clock input and output pins, refer to the *Cyclone IV Device I/O Features* chapter.

Cyclone IV PLLs can drive out to any regular I/O pin through the GCLK. You can also use the external clock output pins as GPIO pins if external PLL clocking is not required.

## Clock Feedback Modes

Cyclone IV PLLs support up to five different clock feedback modes. Each mode allows clock multiplication and division, phase shifting, and programmable duty cycle. For the supported feedback modes, refer to [Table 5-5 on page 5-18](#) for Cyclone IV GX PLLs and [Table 5-6 on page 5-19](#) for Cyclone IV E PLLs.



Input and output delays are fully compensated by the PLL only if you are using the dedicated clock input pins associated with a given PLL as the clock sources.

When driving the PLL using the GCLK network, the input and output delays may not be fully compensated in the Quartus II software.

### Source-Synchronous Mode

If the data and clock arrive at the same time at the input pins, the phase relationship between the data and clock remains the same at the data and clock ports of any I/O element input register.

[Figure 5-12](#) shows an example waveform of the data and clock in this mode. Use this mode for source-synchronous data transfers. Data and clock signals at the I/O element experience similar buffer delays as long as the same I/O standard is used.

**Figure 5-12. Phase Relationship Between Data and Clock in Source-Synchronous Mode**

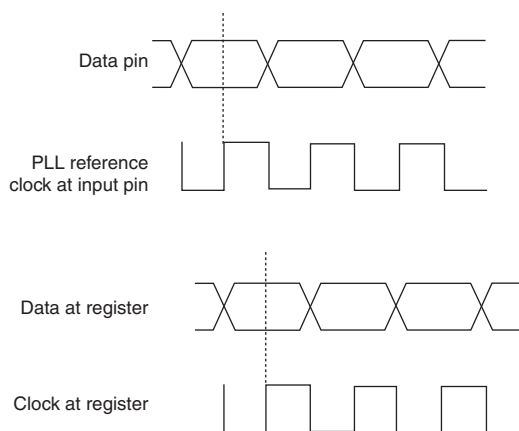

Source-synchronous mode compensates for delay of the clock network used, including any difference in the delay between the following two paths:

- Data pin to I/O element register input
- Clock input pin to the PLL phase frequency detector (PFD) input



Set the input pin to the register delay chain in the I/O element to zero in the Quartus II software for all data pins clocked by a source-synchronous mode PLL. Also, all data pins must use the **PLL COMPENSATED** logic option in the Quartus II software.

## No Compensation Mode

In no compensation mode, the PLL does not compensate for any clock networks. This provides better jitter performance because clock feedback into the PFD does not pass through as much circuitry. Both the PLL internal and external clock outputs are phase shifted with respect to the PLL clock input.

Figure 5-13 shows a waveform example of the phase relationship of the PLL clock in this mode.

**Figure 5-13. Phase Relationship Between PLL Clocks in No Compensation Mode**

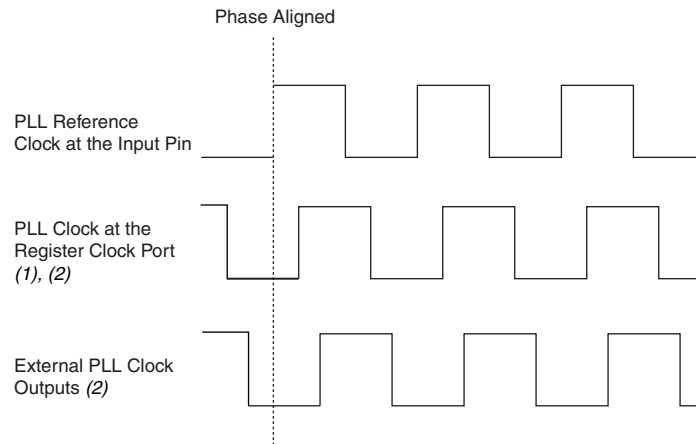

**Notes to Figure 5-13:**

- (1) Internal clocks fed by the PLL are phase-aligned to each other.
- (2) The PLL clock outputs can lead or lag the PLL input clocks.

## Normal Mode

An internal clock in normal mode is phase-aligned to the input clock pin. The external clock output pin has a phase delay relative to the clock input pin if connected in this mode. The Quartus II software timing analyzer reports any phase difference between the two. In normal mode, the PLL fully compensates the delay introduced by the GCLK network.

Figure 5-14 shows a waveform example of the phase relationship of the PLL clocks in this mode.

**Figure 5-14. Phase Relationship Between PLL Clocks in Normal Mode**

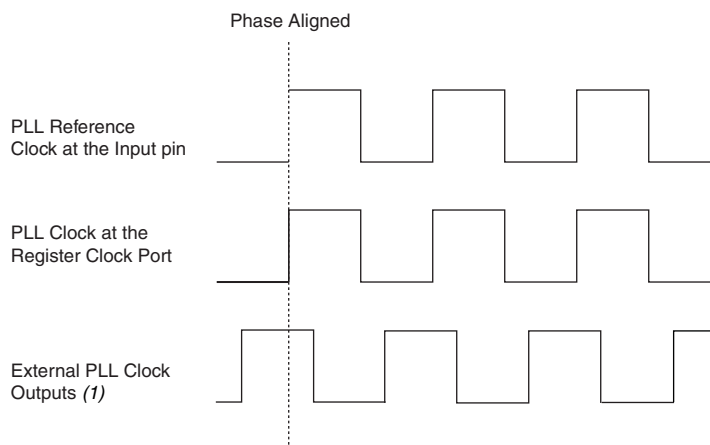

**Note to Figure 5-14:**

(1) The external clock output can lead or lag the PLL internal clock signals.

## Zero Delay Buffer Mode

In zero delay buffer (ZDB) mode, the external clock output pin is phase-aligned with the clock input pin for zero delay through the device. When using this mode, use the same I/O standard on the input clock and output clocks to guarantee clock alignment at the input and output pins.

Figure 5-15 shows an example waveform of the phase relationship of the PLL clocks in ZDB mode.

**Figure 5-15. Phase Relationship Between PLL Clocks in ZDB Mode**

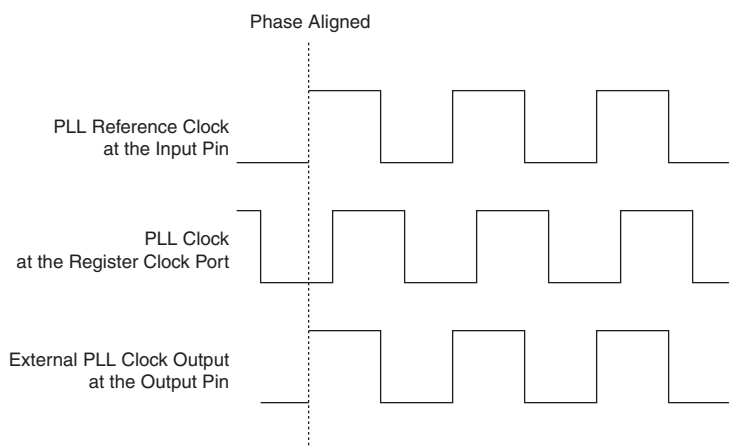

## Deterministic Latency Compensation Mode

The deterministic latency mode compensates for the delay of the multipurpose PLLs through the clock network and serializer in Common Public Radio Interface (CPRI) applications. In this mode, the PLL PFD feedback path compensates the latency uncertainty in Tx dataout and Tx clkout paths relative to the reference clock.

## Hardware Features

Cyclone IV PLLs support several features for general-purpose clock management. This section discusses clock multiplication and division implementation, phase shifting implementations, and programmable duty cycles.

### Clock Multiplication and Division

Each Cyclone IV PLL provides clock synthesis for PLL output ports using  $M/(N \times \text{post-scale counter})$  scaling factors. The input clock is divided by a pre-scale factor,  $N$ , and is then multiplied by the  $M$  feedback factor. The control loop drives the VCO to match  $f_{IN} (M/N)$ . Each output port has a unique post-scale counter that divides down the high-frequency VCO. For multiple PLL outputs with different frequencies, the VCO value is the least common multiple of the output frequencies that meets its frequency specifications. For example, if output frequencies required from one PLL are 33 and 66 MHz, the Quartus II software sets the VCO to 660 MHz (the least common multiple of 33 and 66 MHz in the VCO range). Then, the post-scale counters scale down the VCO frequency for each output port.

There is one pre-scale counter,  $N$ , and one multiply counter,  $M$ , per PLL, with a range of 1 to 512 for both  $M$  and  $N$ . The  $N$  counter does not use duty cycle control because the purpose of this counter is only to calculate frequency division. There are five generic post-scale counters per PLL that can feed GCLKs or external clock outputs. These post-scale counters range from 1 to 512 with a 50% duty cycle setting. The post-scale counters range from 1 to 256 with any non-50% duty cycle setting. The sum of the high/low count values chosen for a design selects the divide value for a given counter.

The Quartus II software automatically chooses the appropriate scaling factors according to the input frequency, multiplication, and division values entered into the ALTPLL megafunction.



Phase alignment between output counters is determined using the  $t_{PLL\_PSERR}$  specification.

## Post-Scale Counter Cascading

PLLs of Cyclone IV devices support post-scale counter cascading to create counters larger than 512. This is implemented by feeding the output of one C counter into the input of the next C counter, as shown in Figure 5-16.

**Figure 5-16. Counter Cascading**

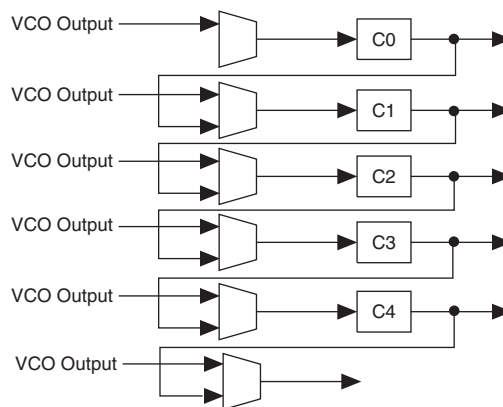

When cascading counters to implement a larger division of the high-frequency VCO clock, the cascaded counters behave as one counter with the product of the individual counter settings.

For example, if  $C0 = 4$  and  $C1 = 2$ , the cascaded value is  $C0 \times C1 = 8$ .



Post-scale counter cascading is automatically set by the Quartus II software in the configuration file. Post-scale counter cascading cannot be performed using the PLL reconfiguration.

## Programmable Duty Cycle

The programmable duty cycle allows PLLs to generate clock outputs with a variable duty cycle. This feature is supported on the PLL post-scale counters. You can achieve the duty cycle setting by a low and high time count setting for the post-scale counters. The Quartus II software uses the frequency input and the required multiply or divide rate to determine the duty cycle choices. The post-scale counter value determines the precision of the duty cycle. The precision is defined by 50% divided by the post-scale counter value. For example, if the C0 counter is 10, steps of 5% are possible for duty cycle choices between 5 to 90%.

Combining the programmable duty cycle with programmable phase shift allows the generation of precise non-overlapping clocks.

## PLL Control Signals

You can use the `pfdena`, `areset`, and `locked` signals to observe and control the PLL operation and resynchronization.



For more information about the PLL control signals, refer to the *ALTPLL Megafunction User Guide*.

## Clock Switchover

The clock switchover feature allows the PLL to switch between two reference input clocks. Use this feature for clock redundancy or for a dual-clock domain application, such as a system that turns on the redundant clock if the previous clock stops running. Your design can automatically perform clock switchover when the clock is no longer toggling, or based on the user control signal, `clkswitch`.

### Automatic Clock Switchover

PLLs of Cyclone IV devices support a fully configurable clock switchover capability.

When the current reference clock is not present, the clock-sense block automatically switches to the backup clock for PLL reference. The clock switchover circuit also sends out three status signals—`clkbad0`, `clkbad1`, and `activeclock`—from the PLL to implement a custom switchover circuit. You can select a clock source at the backup clock by connecting it to the `inclk1` port of the PLL in your design.

Figure 5-17 shows the block diagram of the switchover circuit built into the PLL.

**Figure 5-17. Automatic Clock Switchover Circuit**

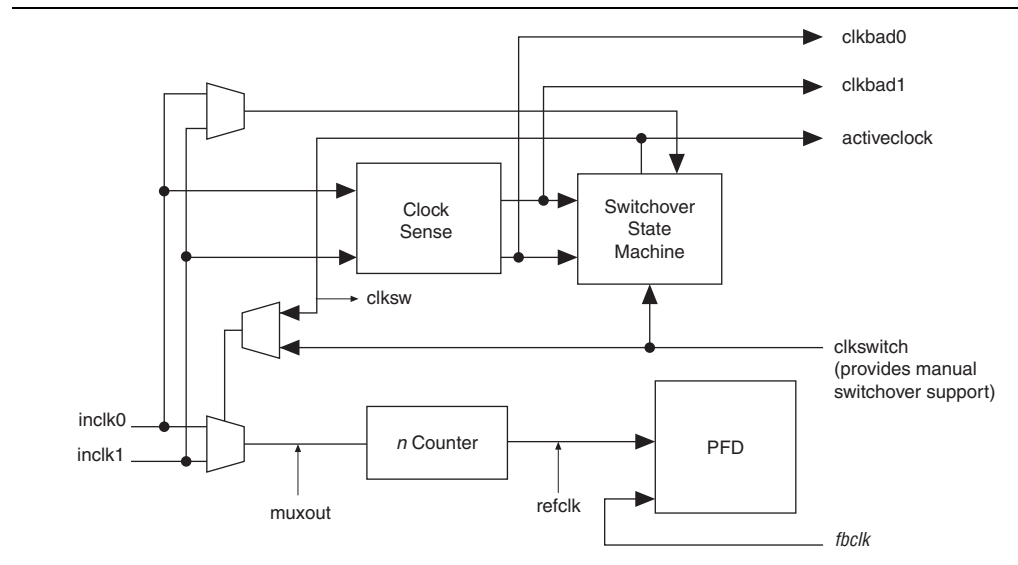

There are two ways to use the clock switchover feature:

- Use the switchover circuitry for switching from `inclk0` to `inclk1` running at the same frequency. For example, in applications that require a redundant clock with the same frequency as the reference clock, the switchover state machine generates a signal that controls the multiplexer select input shown in Figure 5-17. In this case, `inclk1` becomes the reference clock for the PLL. This automatic switchover can switch back and forth between the `inclk0` and `inclk1` clocks any number of times, when one of the two clocks fails and the other clock is available.
- Use the `clkswitch` input for user- or system-controlled switch conditions. This is possible for same-frequency switchover or to switch between inputs of different frequencies. For example, if `inclk0` is 66 MHz and `inclk1` is 200 MHz, you must control the switchover because the automatic clock-sense circuitry cannot monitor primary and secondary clock frequencies with a frequency difference of more than

20%. This feature is useful when clock sources can originate from multiple cards on the backplane, requiring a system-controlled switchover between frequencies of operation. Choose the secondary clock frequency so the VCO operates in the recommended frequency range. Also, set the M, N, and C counters accordingly to keep the VCO operating frequency in the recommended range.

Figure 5-18 shows a waveform example of the switchover feature when using automatic loss of clock detection. Here, the `inclk0` signal remains low. After the `inclk0` signal remains low for approximately two clock cycles, the clock-sense circuitry drives the `clkbad0` signal high. Also, because the reference clock signal is not toggling, the switchover state machine controls the multiplexer through the `clksw` signal to switch to `inclk1`.

**Figure 5-18. Automatic Switchover Upon Clock Loss Detection (1)**

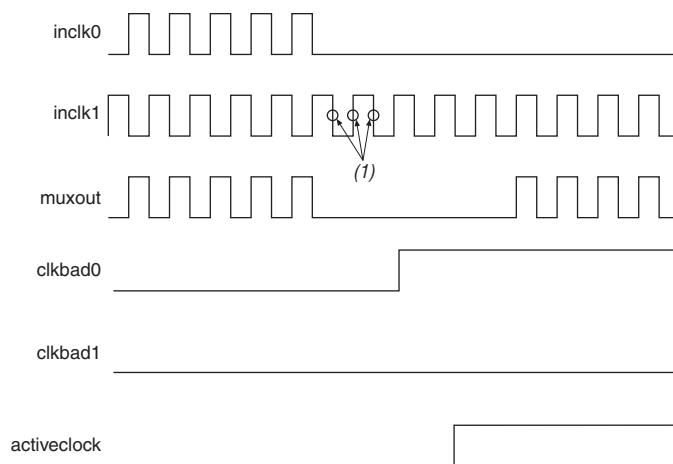

**Note to Figure 5-18:**

(1) Switchover is enabled on the falling edge of `inclk0` or `inclk1`, depending on which clock is available. In this figure, switchover is enabled on the falling edge of `inclk1`.

### Manual Override

If you are using the automatic switchover, you must switch input clocks with the manual override feature with the `clkswitch` input.

Figure 5-19 shows an example of a waveform illustrating the switchover feature when controlled by `clkswitch`. In this case, both clock sources are functional and `inclk0` is selected as the reference clock. A low-to-high transition of the `clkswitch` signal starts the switchover sequence. The `clkswitch` signal must be high for at least three clock cycles (at least three of the longer clock period if `inclk0` and `inclk1` have different frequencies). On the falling edge of `inclk0`, the reference clock of the counter, `muxout`, is gated off to prevent any clock glitching. On the falling edge of `inclk1`, the reference clock multiplexer switches from `inclk0` to `inclk1` as the PLL reference, and the `activeclock` signal changes to indicate which clock is currently feeding the PLL.

In this mode, the `activeclock` signal mirrors the `clkswitch` signal. As both blocks are still functional during the manual switch, neither `clkbad` signals go high. Because the switchover circuit is positive edge-sensitive, the falling edge of the `clkswitch` signal does not cause the circuit to switch back from `inclk1` to `inclk0`. When the `clkswitch` signal goes high again, the process repeats. The `clkswitch` signal and the automatic switch only works depending on the availability of the clock that is switched to. If the clock is unavailable, the state machine waits until the clock is available.

 When `CLKSWITCH = 1`, it overrides the automatic switch-over function. As long as `clkswitch` signal is high, further switch-over action is blocked.

**Figure 5-19. Clock Switchover Using the `clkswitch` Control (1)**

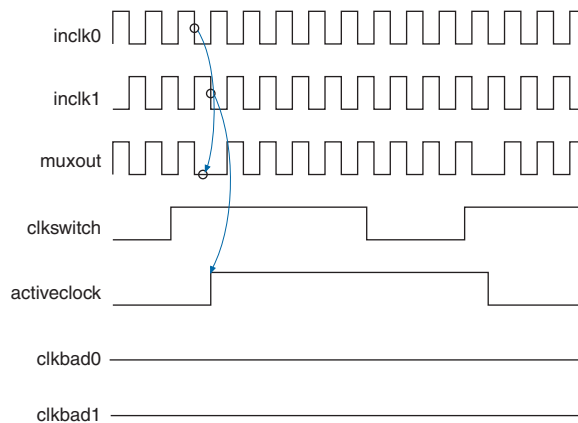

**Note to Figure 5-19:**

(1) Both `inclk0` and `inclk1` must be running when the `clkswitch` signal goes high to start a manual clock switchover event.

## Manual Clock Switchover

PLLs of Cyclone IV devices support manual switchover, in which the `clkswitch` signal controls whether `inclk0` or `inclk1` is the input clock to the PLL. The characteristics of a manual switchover are similar to the manual override feature in an automatic clock switchover, in which the switchover circuit is edge-sensitive. When the `clkswitch` signal goes high, the switchover sequence starts. The falling edge of the `clkswitch` signal does not cause the circuit to switch back to the previous input clock.

 For more information about PLL software support in the Quartus II software, refer to the [ALTPLL Megafunction User Guide](#).

## Guidelines

Use the following guidelines to design with clock switchover in PLLs:

- Clock loss detection and automatic clock switchover require the `inclk0` and `inclk1` frequencies be within 20% of each other. Failing to meet this requirement causes the `clkbad0` and `clkbad1` signals to function improperly.

- When using manual clock switchover, the difference between `inclk0` and `inclk1` can be more than 20%. However, differences between the two clock sources (frequency, phase, or both) can cause the PLL to lose lock. Resetting the PLL ensures that the correct phase relationships are maintained between the input and output clocks.
- Both `inclk0` and `inclk1` must be running when the `clkswitch` signal goes high to start the manual clock switchover event. Failing to meet this requirement causes the clock switchover to malfunction.
- Applications that require a clock switchover feature and a small frequency drift must use a low-bandwidth PLL. When referencing input clock changes, the low-bandwidth PLL reacts slower than a high-bandwidth PLL. When the switchover happens, the low-bandwidth PLL propagates the stopping of the clock to the output slower than the high-bandwidth PLL. The low-bandwidth PLL filters out jitter on the reference clock. However, the low-bandwidth PLL also increases lock time.
- After a switchover occurs, there may be a finite resynchronization period for the PLL to lock onto a new clock. The exact amount of time it takes for the PLL to re-lock is dependent on the PLL configuration.
- If the phase relationship between the input clock to the PLL and output clock from the PLL is important in your design, assert `areset` for 10 ns after performing a clock switchover. Wait for the locked signal (or gated lock) to go high before re-enabling the output clocks from the PLL.
- **Figure 5-20** shows how the VCO frequency gradually decreases when the primary clock is lost and then increases as the VCO locks on to the secondary clock. After the VCO locks on to the secondary clock, some overshoot can occur (an over-frequency condition) in the VCO frequency.

**Figure 5-20. VCO Switchover Operating Frequency**

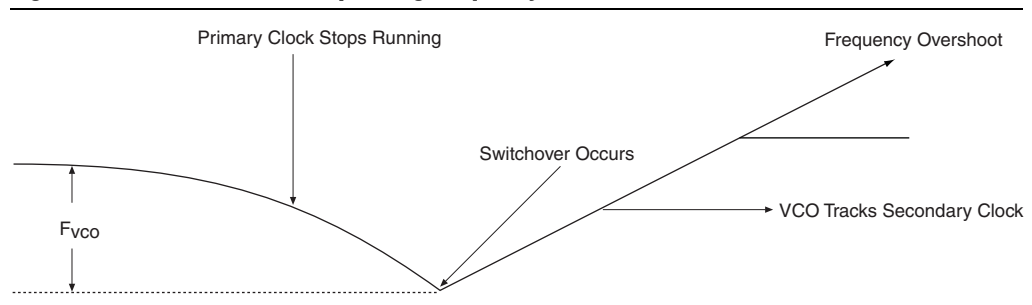

- Disable the system during switchover if the system is not tolerant to frequency variations during the PLL resynchronization period. You can use the `clkbad0` and `clkbad1` status signals to turn off the PFD (`pfdena = 0`) so the VCO maintains its last frequency. You can also use the switchover state machine to switch over to the secondary clock. Upon enabling the PFD, output clock enable signals (`clkena`) can disable clock outputs during the switchover and resynchronization period. After the lock indication is stable, the system can re-enable the output clock or clocks.

## Programmable Bandwidth

The PLL bandwidth is the measure of the PLL's ability to track the input clock and its associated jitter. PLLs of Cyclone IV devices provide advanced control of the PLL bandwidth using the programmable characteristics of the PLL loop, including loop filter and charge pump. The closed-loop gain 3-dB frequency in the PLL determines the PLL bandwidth. The bandwidth is approximately the unity gain point for open loop PLL response.

## Phase Shift Implementation

Phase shift is used to implement a robust solution for clock delays in Cyclone IV devices. Phase shift is implemented with a combination of the VCO phase output and the counter starting time. The VCO phase output and counter starting time are the most accurate methods of inserting delays, because they are based only on counter settings that are independent of process, voltage, and temperature.

You can phase shift the output clocks from the PLLs of Cyclone IV devices in one of two ways:

- Fine resolution using VCO phase taps
- Coarse resolution using counter starting time

Fine resolution phase shifts are implemented by allowing any of the output counters (C[4..0]) or the M counter to use any of the eight phases of the VCO as the reference clock. This allows you to adjust the delay time with a fine resolution.

Equation 5-1 shows the minimum delay time that you can insert using this method.

### Equation 5-1. Fine Resolution Phase Shift

$$\tau_{\text{fine}} = \frac{T_{VCO}}{8} = \frac{1}{8f_{VCO}} = \frac{N}{8Mf_{REF}}$$

in which  $f_{REF}$  is the input reference clock frequency.

For example, if  $f_{REF}$  is 100 MHz,  $N = 1$ , and  $M = 8$ , then  $f_{VCO} = 800$  MHz, and  $\Phi_{\text{fine}} = 156.25$  ps. The PLL operating frequency defines this phase shift, a value that depends on reference clock frequency and counter settings.

Coarse resolution phase shifts are implemented by delaying the start of the counters for a predetermined number of counter clocks. Equation 5-2 shows the coarse phase shift.

### Equation 5-2. Coarse Resolution Phase Shift

$$\tau_{\text{coarse}} = \frac{C-1}{f_{VCO}} = \frac{(C-1)N}{Mf_{REF}}$$

C is the count value set for the counter delay time (this is the initial setting in the PLL usage section of the compilation report in the Quartus II software). If the initial value is 1,  $C - 1 = 0^\circ$  phase shift.

Figure 5–21 shows an example of phase shift insertion using fine resolution through VCO phase taps method. The eight phases from the VCO are shown and labeled for reference. In this example, CLK0 is based on 0° phase from the VCO and has the C value for the counter set to one. The CLK1 signal is divided by four, two VCO clocks for high time and two VCO clocks for low time. CLK1 is based on the 135° phase tap from the VCO and has the C value for the counter set to one. The CLK1 signal is also divided by four. In this case, the two clocks are offset by  $3 \Phi_{\text{fine}}$ . CLK2 is based on the 0° phase from the VCO but has the C value for the counter set to three. This creates a delay of two  $\Phi_{\text{coarse}}$  (two complete VCO periods).

**Figure 5–21. Delay Insertion Using VCO Phase Output and Counter Delay Time**

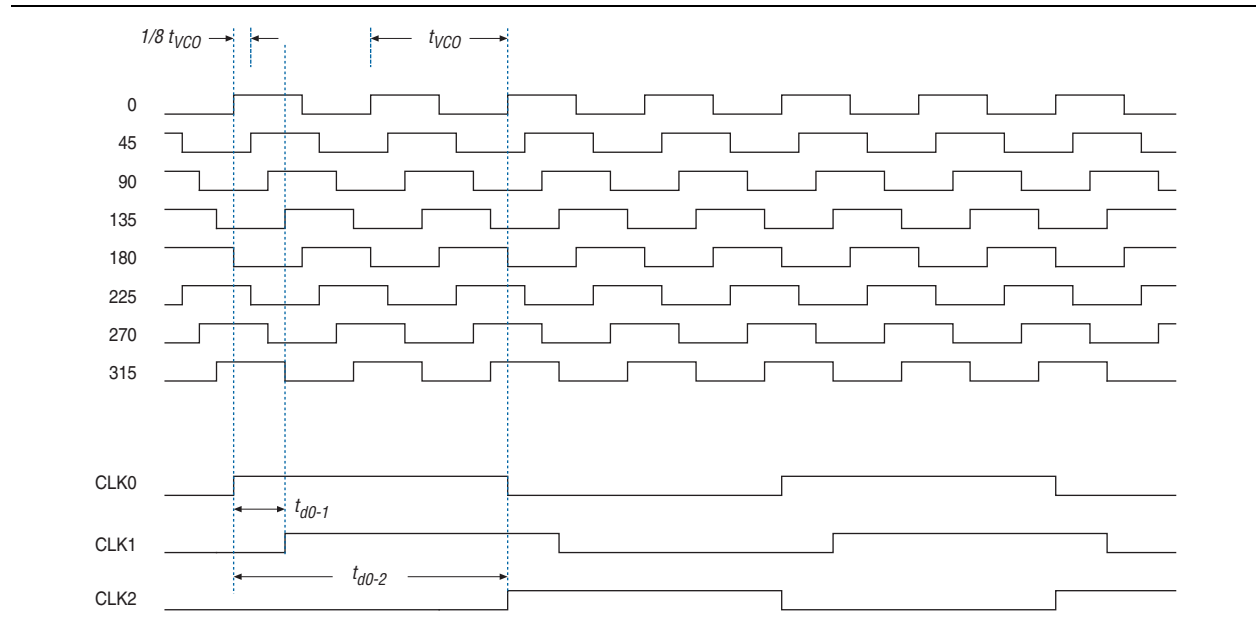



You can use the coarse and fine phase shifts to implement clock delays in Cyclone IV devices.

Cyclone IV devices support dynamic phase shifting of VCO phase taps only. The phase shift is configurable for any number of times. Each phase shift takes about one scanclk cycle, allowing you to implement large phase shifts quickly.

## PLL Cascading

Cyclone IV devices allow cascading between general purpose PLLs and multipurpose PLLs in normal or direct mode through the GCLK network. If your design cascades PLLs, the source (upstream) PLL must have a low-bandwidth setting, while the destination (downstream) PLL must have a high-bandwidth setting.

-  PLL\_6 and PLL7 have upstream cascading capability only.
-  PLL cascading is not supported when used in transceiver applications.

## PLL Reconfiguration

PLLs use several divide counters and different VCO phase taps to perform frequency synthesis and phase shifts. In PLLs of Cyclone IV devices, you can reconfigure both counter settings and phase shift the PLL output clock in real time. You can also change the charge pump and loop filter components, which dynamically affects PLL bandwidth. You can use these PLL components to update the output clock frequency, PLL bandwidth, and phase shift in real time, without reconfiguring the entire FPGA.

The ability to reconfigure the PLL in real time is useful in applications that might operate at multiple frequencies. It is also useful in prototyping environments, allowing you to sweep PLL output frequencies and adjust the output clock phase dynamically. For instance, a system generating test patterns is required to generate and send patterns at 75 or 150 MHz, depending on the requirements of the device under test. Reconfiguring PLL components in real time allows you to switch between two such output frequencies in a few microseconds.

You can also use this feature to adjust clock-to-out ( $t_{CO}$ ) delays in real time by changing the PLL output clock phase shift. This approach eliminates the need to regenerate a configuration file with the new PLL settings.

### PLL Reconfiguration Hardware Implementation

The following PLL components are configurable in real time:

- Pre-scale counter (N)
- Feedback counter (M)
- Post-scale output counters (C0–C4)
- Dynamically adjust the charge pump current ( $I_{CP}$ ) and loop filter components (R, C) to facilitate on-the-fly reconfiguration of the PLL bandwidth

Figure 5–22 shows how to adjust PLL counter settings dynamically by shifting their new settings into a serial shift register chain or scan chain. Serial data shifts to the scan chain via the `scandata` port, and shift registers are clocked by `scanclock`. The maximum `scanclock` frequency is 100 MHz. After shifting the last bit of data, asserting the `configupdate` signal for at least one `scanclock` clock cycle synchronously updates the PLL configuration bits with the data in the scan registers.

**Figure 5–22. PLL Reconfiguration Scan Chain**

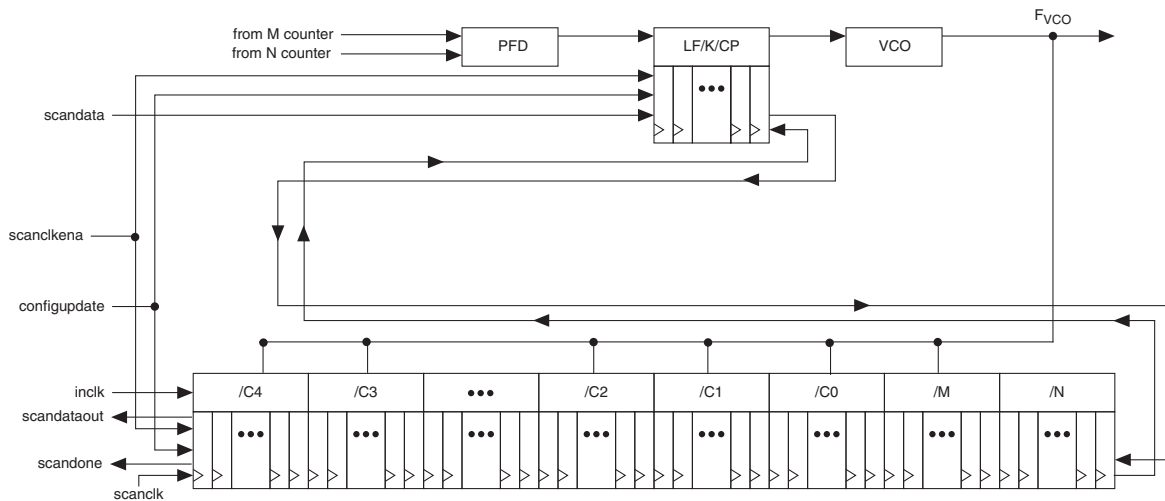

 The counter settings are updated synchronously to the clock frequency of the individual counters. Therefore, not all counters update simultaneously.

To reconfigure the PLL counters, perform the following steps:

1. The `scanclockena` signal is asserted at least one `scanclock` cycle prior to shifting in the first bit of `scandata` (D0).
2. Serial data (`scandata`) is shifted into the scan chain on the second rising edge of `scanclock`.
3. After all 144 bits have been scanned into the scan chain, the `scanclockena` signal is de-asserted to prevent inadvertent shifting of bits in the scan chain.
4. The `configupdate` signal is asserted for one `scanclock` cycle to update the PLL counters with the contents of the scan chain.
5. The `scandone` signal goes high indicating that the PLL is being reconfigured. A falling edge indicates that the PLL counters have been updated with new settings.
6. Reset the PLL using the `areset` signal if you make any changes to the M, N, post-scale output C counters, or the  $I_{CP}$ , R, C settings.
7. You can repeat steps 1 through 5 to reconfigure the PLL any number of times.

Figure 5-23 shows a functional simulation of the PLL reconfiguration feature.

**Figure 5-23. PLL Reconfiguration Scan Chain**

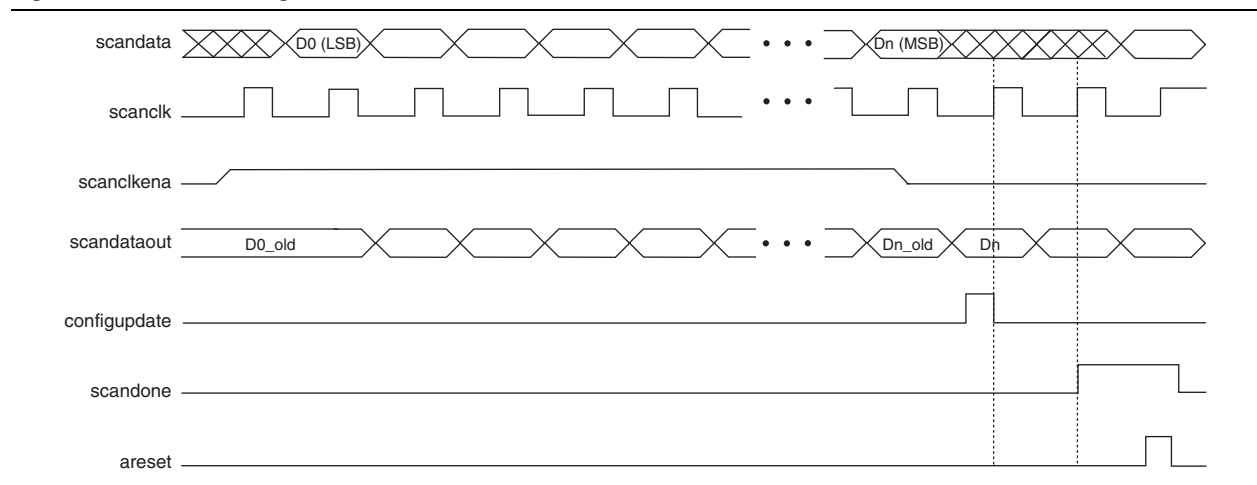

 When reconfiguring the counter clock frequency, the corresponding counter phase shift settings cannot be reconfigured using the same interface. You can reconfigure phase shifts in real time using the dynamic phase shift reconfiguration interface. If you reconfigure the counter frequency, but wish to keep the same non-zero phase shift setting (for example, 90°) on the clock output, you must reconfigure the phase shift after reconfiguring the counter clock frequency.

### Post-Scale Counters (C0 to C4)

You can configure multiply or divide values and duty cycle of post-scale counters in real time. Each counter has an 8-bit high time setting and an 8-bit low time setting. The duty cycle is the ratio of output high or low time to the total cycle time, that is the sum of the two. Additionally, these counters have two control bits, `rbypass`, for bypassing the counter, and `rse1odd`, to select the output clock duty cycle.

When the `rbypass` bit is set to 1, it bypasses the counter, resulting in a divide by one. When this bit is set to 0, the PLL computes the effective division of the VCO output frequency based on the high and low time counters. For example, if the post-scale divide factor is 10, the high and low count values are set to 5 and 5, to achieve a 50–50% duty cycle. The PLL implements this duty cycle by transitioning the output clock from high-to-low on the rising edge of the VCO output clock. However, a 4 and 6 setting for the high and low count values, respectively, would produce an output clock with a 40–60% duty cycle.

The `rse1odd` bit indicates an odd divide factor for the VCO output frequency with a 50% duty cycle. For example, if the post-scale divide factor is three, the high and low time count values are 2 and 1, respectively, to achieve this division. This implies a 67%–33% duty cycle. If you need a 50%–50% duty cycle, you must set the `rse1odd` control bit to 1 to achieve this duty cycle despite an odd division factor. The PLL implements this duty cycle by transitioning the output clock from high-to-low on a falling edge of the VCO output clock. When you set `rse1odd` = 1, subtract 0.5 cycles from the high time and add 0.5 cycles to the low time.

For example:

- High time count = 2 cycles

- Low time count = 1 cycle
- `rse1odd = 1` effectively equals:
  - High time count = 1.5 cycles
  - Low time count = 1.5 cycles
  - Duty cycle = (1.5/3)% high time count and (1.5/3)% low time count

### Scan Chain Description

Cyclone IV PLLs have a 144-bit scan chain.

Table 5-7 lists the number of bits for each component of the PLL.

**Table 5-7. Cyclone IV PLL Reprogramming Bits**

Block Name	Number of Bits		
	Counter	Other	Total
C4 <sup>(1)</sup>	16	2 <sup>(2)</sup>	18
C3	16	2 <sup>(2)</sup>	18
C2	16	2 <sup>(2)</sup>	18
C1	16	2 <sup>(2)</sup>	18
C0	16	2 <sup>(2)</sup>	18
M	16	2 <sup>(2)</sup>	18
N	16	2 <sup>(2)</sup>	18
Charge Pump	9	0	9
Loop Filter <sup>(3)</sup>	9	0	9
<b>Total number of bits:</b>			144

**Notes to Table 5-7:**

- (1) LSB bit for C4 low-count value is the first bit shifted into the scan chain.
- (2) These two control bits include `rbypass`, for bypassing the counter, and `rse1odd`, to select the output clock duty cycle.
- (3) MSB bit for loop filter is the last bit shifted into the scan chain.

Figure 5-24 shows the scan chain order of the PLL components.

**Figure 5-24. PLL Component Scan Chain Order**

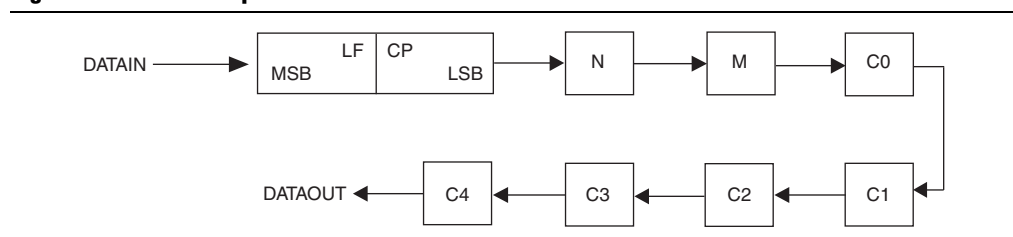
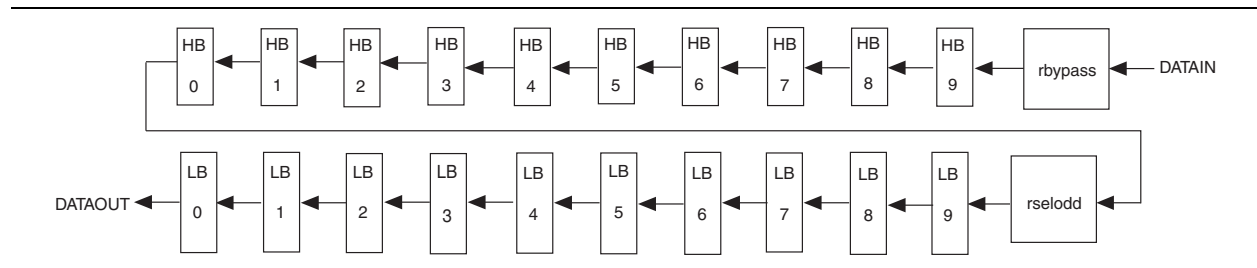

Figure 5-25 shows the scan chain bit order sequence for one PLL post-scale counter in PLLs of Cyclone IV devices.

**Figure 5-25. Scan Chain Bit Order**



### Charge Pump and Loop Filter

You can reconfigure the charge pump and loop filter settings to update the PLL bandwidth in real time. Table 5-8 through Table 5-10 list the possible settings for charge pump current ( $I_{CP}$ ), loop filter resistor ( $R$ ), and capacitor ( $C$ ) values for PLLs of Cyclone IV devices.

**Table 5-8. Charge Pump Bit Control**

CP[2]	CP[1]	CP[0]	Setting (Decimal)
0	0	0	0
1	0	0	1
1	1	0	3
1	1	1	7

**Table 5-9. Loop Filter Resistor Value Control**

LFR[4]	LFR[3]	LFR[2]	LFR[1]	LFR[0]	Setting (Decimal)
0	0	0	0	0	0
0	0	0	1	1	3
0	0	1	0	0	4
0	1	0	0	0	8
1	0	0	0	0	16
1	0	0	1	1	19
1	0	1	0	0	20
1	1	0	0	0	24
1	1	0	1	1	27
1	1	1	0	0	28
1	1	1	1	0	30

**Table 5–10. Loop Filter Control of High Frequency Capacitor**

LFC[1]	LFC[0]	Setting (Decimal)
0	0	0
0	1	1
1	1	3

### Bypassing a PLL Counter

Bypassing a PLL counter results in a divide (N, C0 to C4 counters) factor of one.

Table 5–11 lists the settings for bypassing the counters in PLLs of Cyclone IV devices.

**Table 5–11. PLL Counter Settings**

PLL Scan Chain Bits [0..8] Settings									Description
LSB								MSB	
X	X	X	X	X	X	X	X	1 <sup>(1)</sup>	PLL counter bypassed
X	X	X	X	X	X	X	X	0 <sup>(1)</sup>	PLL counter not bypassed

**Note to Table 5–11:**

(1) Bypass bit.

To bypass any of the PLL counters, set the bypass bit to 1. The values on the other bits are then ignored.

### Dynamic Phase Shifting

The dynamic phase shifting feature allows the output phase of individual PLL outputs to be dynamically adjusted relative to each other and the reference clock without sending serial data through the scan chain of the corresponding PLL. This feature simplifies the interface and allows you to quickly adjust  $t_{CO}$  delays by changing output clock phase shift in real time. This is achieved by incrementing or decrementing the VCO phase-tap selection to a given C counter or to the M counter. The phase is shifted by 1/8 the VCO frequency at a time. The output clocks are active during this phase reconfiguration process.

Table 5–12 lists the control signals that are used for dynamic phase shifting.

**Table 5–12. Dynamic Phase Shifting Control Signals (Part 1 of 2)**

Signal Name	Description	Source	Destination
phasecounterselect [2..0]	Counter Select. Three bits decoded to select either the M or one of the C counters for phase adjustment. One address map to select all C counters. This signal is registered in the PLL on the rising edge of scanclk.	Logic array or I/O pins	PLL reconfiguration circuit
phaseupdown	Selects dynamic phase shift direction; 1= UP, 0 = DOWN. Signal is registered in the PLL on the rising edge of scanclk.	Logic array or I/O pins	PLL reconfiguration circuit
phasestep	Logic high enables dynamic phase shifting.	Logic array or I/O pins	PLL reconfiguration circuit

**Table 5–12. Dynamic Phase Shifting Control Signals (Part 2 of 2)**

Signal Name	Description	Source	Destination
scanclk	Free running clock from core used in combination with <code>phasetestep</code> to enable or disable dynamic phase shifting. Shared with <code>scanclk</code> for dynamic reconfiguration.	GCLK or I/O pins	PLL reconfiguration circuit
phasedone	When asserted, it indicates to core logic that the phase adjustment is complete and PLL is ready to act on a possible second adjustment pulse. Asserts based on internal PLL timing. De-asserts on the rising edge of <code>scanclk</code> .	PLL reconfiguration circuit	Logic array or I/O pins

Table 5–13 lists the PLL counter selection based on the corresponding `PHASECOUNTERSELECT` setting.

**Table 5–13. Phase Counter Select Mapping**

phasecounterselect			Selects
[2]	[1]	[0]	
0	0	0	All Output Counters
0	0	1	M Counter
0	1	0	C0 Counter
0	1	1	C1 Counter
1	0	0	C2 Counter
1	0	1	C3 Counter
1	1	0	C4 Counter

To perform one dynamic phase-shift, follow these steps:

1. Set `PHASEUPDOWN` and `PHASECOUNTERSELECT` as required.
2. Assert `PHASESTEP` for at least two `SCANCLK` cycles. Each `PHASESTEP` pulse allows one phase shift.
3. Deassert `PHASESTEP` after `PHASEDONE` goes low.
4. Wait for `PHASEDONE` to go high.
5. Repeat steps 1 through 4 as many times as required to perform multiple phase-shifts.

`PHASEUPDOWN` and `PHASECOUNTERSELECT` signals are synchronous to `SCANCLK` and must meet the  $t_{su}$  and  $t_h$  requirements with respect to the `SCANCLK` edges.



You can repeat dynamic phase-shifting indefinitely. For example, in a design where the VCO frequency is set to 1,000 MHz and the output clock frequency is set to 100 MHz, performing 40 dynamic phase shifts (each one yields 125 ps phase shift) results in shifting the output clock by 180°, in other words, a phase shift of 5 ns.

Figure 5-26 shows the dynamic phase shifting waveform.

**Figure 5-26. PLL Dynamic Phase Shift**

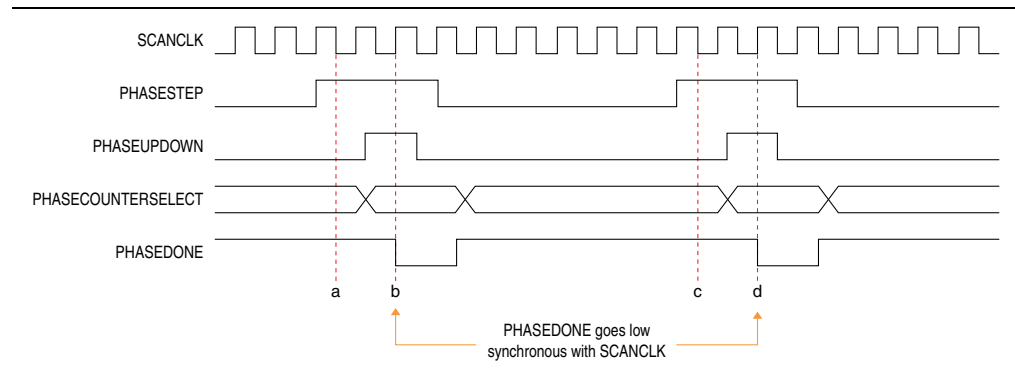

The PHASESTEP signal is latched on the negative edge of SCANCLK (a,c) and must remain asserted for at least two SCANCLK cycles. Deassert PHASESTEP after PHASEDONE goes low. On the second SCANCLK rising edge (b,d) after PHASESTEP is latched, the values of PHASEUPDOWN and PHASECOUNTERSELECT are latched and the PLL starts dynamic phase-shifting for the specified counters, and in the indicated direction. PHASEDONE is deasserted synchronous to SCANCLK at the second rising edge (b,d) and remains low until the PLL finishes dynamic phase-shifting. Depending on the VCO and SCANCLK frequencies, PHASEDONE low time may be greater than or less than one SCANCLK cycle.

You can perform another dynamic phase-shift after the PHASEDONE signal goes from low to high. Each PHASESTEP pulse enables one phase shift. PHASESTEP pulses must be at least one SCANCLK cycle apart.

 For information about the ALTPLL\_RECONFIG MegaWizard™ Plug-In Manager, refer to the [ALTPLL\\_RECONFIG Megafunction User Guide](#).

## Spread-Spectrum Clocking

Cyclone IV devices can accept a spread-spectrum input with typical modulation frequencies. However, the device cannot automatically detect that the input is a spread-spectrum signal. Instead, the input signal looks like deterministic jitter at the input of the PLL. PLLs of Cyclone IV devices can track a spread-spectrum input clock as long as it is in the input jitter tolerance specifications and the modulation frequency of the input clock is below the PLL bandwidth, that is specified in the fitter report. Cyclone IV devices cannot generate spread-spectrum signals internally.

## PLL Specifications

 For information about PLL specifications, refer to the [Cyclone IV Device Datasheet](#) chapter.

## Document Revision History

Table 5-14 lists the revision history for this chapter.

**Table 5-14. Document Revision History**

Date	Version	Changes
October 2012	2.4	<ul style="list-style-type: none"> <li>■ Updated “Manual Override” and “PLL Cascading” sections.</li> <li>■ Updated Figure 5-9.</li> </ul>
November 2011	2.3	<ul style="list-style-type: none"> <li>■ Updated the “Dynamic Phase Shifting” section.</li> <li>■ Updated Figure 5-26.</li> </ul>
December 2010	2.2	<ul style="list-style-type: none"> <li>■ Updated for the Quartus II software version 10.1 release.</li> <li>■ Updated Figure 5-3 and Figure 5-10.</li> <li>■ Updated “GCLK Network Clock Source Generation”, “PLLs in Cyclone IV Devices”, and “Manual Override” sections.</li> <li>■ Minor text edits.</li> </ul>
July 2010	2.1	<ul style="list-style-type: none"> <li>■ Updated Figure 5-2, Figure 5-3, Figure 5-4, and Figure 5-10.</li> <li>■ Updated Table 5-1, Table 5-2, and Table 5-5.</li> <li>■ Updated “Clock Feedback Modes” section.</li> </ul>
February 2010	2.0	<ul style="list-style-type: none"> <li>■ Added Cyclone IV E devices information for the Quartus II software version 9.1 SP1 release.</li> <li>■ Updated “Clock Networks” section.</li> <li>■ Updated Table 5-1 and Table 5-2.</li> <li>■ Added Table 5-3.</li> <li>■ Updated Figure 5-2, Figure 5-3, and Figure 5-9.</li> <li>■ Added Figure 5-4 and Figure 5-10.</li> </ul>
November 2009	1.0	Initial release.

This section provides information about Cyclone® IV device family I/O features and high-speed differential and external memory interfaces.

This section includes the following chapters:

- [Chapter 6, I/O Features in Cyclone IV Devices](#)
- [Chapter 7, External Memory Interfaces in Cyclone IV Devices](#)

### Revision History

Refer to each chapter for its own specific revision history. For information about when each chapter was updated, refer to the Chapter Revision Dates section, which appears in the complete handbook.



This chapter describes the I/O and high speed I/O capabilities and features offered in Cyclone® IV devices.

The I/O capabilities of Cyclone IV devices are driven by the diversification of I/O standards in many low-cost applications, and the significant increase in required I/O performance. Altera's objective is to create a device that accommodates your key board design needs with ease and flexibility.

The I/O flexibility of Cyclone IV devices is increased from the previous generation low-cost FPGAs by allowing all I/O standards to be selected on all I/O banks. Improvements to on-chip termination (OCT) support and the addition of true differential buffers have eliminated the need for external resistors in many applications, such as display system interfaces.

High-speed differential I/O standards have become popular in high-speed interfaces because of their significant advantages over single-ended I/O standards. The Cyclone IV devices support LVDS, BLVDS, RSDS, mini-LVDS, and PPDS. The transceiver reference clocks and the existing general-purpose I/O (GPIO) clock input features also support the LVDS I/O standards.

The Quartus® II software completes the solution with powerful pin planning features that allow you to plan and optimize I/O system designs even before the design files are available.

This chapter includes the following sections:

- "Cyclone IV I/O Elements" on page 6-2
- "I/O Element Features" on page 6-3
- "OCT Support" on page 6-6
- "I/O Standards" on page 6-11
- "Termination Scheme for I/O Standards" on page 6-13
- "I/O Banks" on page 6-16

- “Pad Placement and DC Guidelines” on page 6-23
- “Clock Pins Functionality” on page 6-23
- “High-Speed I/O Interface” on page 6-24
- “High-Speed I/O Standards Support” on page 6-28
- “True Differential Output Buffer Feature” on page 6-35
- “High-Speed I/O Timing” on page 6-36
- “Design Guidelines” on page 6-37
- “Software Overview” on page 6-38

## Cyclone IV I/O Elements

Cyclone IV I/O elements (IOEs) contain a bidirectional I/O buffer and five registers for registering input, output, output-enable signals, and complete embedded bidirectional single-data rate transfer. I/O pins support various single-ended and differential I/O standards.

The IOE contains one input register, two output registers, and two output-enable (OE) registers. The two output registers and two OE registers are used for DDR applications. You can use input registers for fast setup times and output registers for fast clock-to-output times. Additionally, you can use OE registers for fast clock-to-output enable timing. You can use IOEs for input, output, or bidirectional data paths.

Figure 6-1 shows the Cyclone IV devices IOE structure for single data rate (SDR) operation.

**Figure 6-1. Cyclone IV IOEs in a Bidirectional I/O Configuration for SDR Mode**

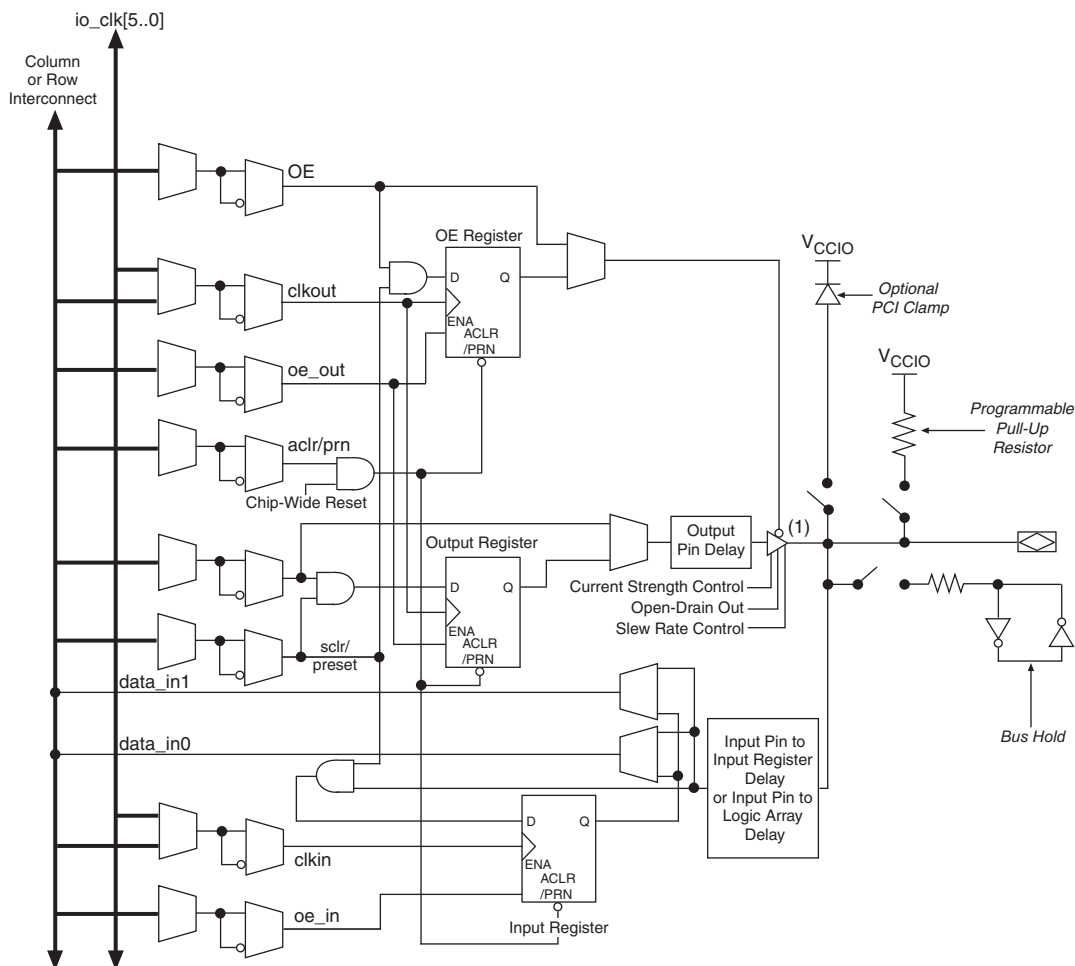

**Note to Figure 6-1:**

(1) Tri-state control is not available for outputs configured with true differential I/O standards.

## I/O Element Features

The Cyclone IV IOE offers a range of programmable features for an I/O pin. These features increase the flexibility of I/O utilization and provide a way to reduce the usage of external discrete components, such as pull-up resistors and diodes.

### Programmable Current Strength

The output buffer for each Cyclone IV I/O pin has a programmable current strength control for certain I/O standards.

The LVTTTL, LVCMOS, SSTL-2 Class I and II, SSTL-18 Class I and II, HSTL-18 Class I and II, HSTL-15 Class I and II, and HSTL-12 Class I and II I/O standards have several levels of current strength that you can control.

Table 6-2 on page 6-7 shows the possible settings for I/O standards with current strength control. These programmable current strength settings are a valuable tool in helping decrease the effects of simultaneously switching outputs (SSO) in conjunction with reducing system noise. The supported settings ensure that the device driver meets the specifications for IOH and IOL of the corresponding I/O standard.

 When you use programmable current strength, on-chip series termination ( $R_S$  OCT) is not available.

## Slew Rate Control

The output buffer for each Cyclone IV I/O pin provides optional programmable output slew-rate control. Table 6-2 on page 6-7 shows the possible slew rate option and the Quartus II default slew rate setting. However, these fast transitions may introduce noise transients in the system. A slower slew rate reduces system noise, but adds a nominal delay to rising and falling edges. Because each I/O pin has an individual slew-rate control, you can specify the slew rate on a pin-by-pin basis. The slew-rate control affects both the rising and falling edges. Slew rate control is available for single-ended I/O standards with current strength of 8 mA or higher.

 You cannot use the programmable slew rate feature when using OCT with calibration.

 You cannot use the programmable slew rate feature when using the 3.0-V PCI, 3.0-V PCI-X, 3.3-V LVTTTL, or 3.3-V LVCMOS I/O standards. Only the fast slew rate (default) setting is available.

## Open-Drain Output

Cyclone IV devices provide an optional open-drain (equivalent to an open-collector) output for each I/O pin. This open-drain output enables the device to provide system-level control signals (for example, interrupt and write enable signals) that are asserted by multiple devices in your system.

## Bus Hold

Each Cyclone IV device user I/O pin provides an optional bus-hold feature. The bus-hold circuitry holds the signal on an I/O pin at its last-driven state. Because the bus-hold feature holds the last-driven state of the pin until the next input signal is present, an external pull-up or pull-down resistor is not necessary to hold a signal level when the bus is tri-stated.

The bus-hold circuitry also pulls undriven pins away from the input threshold voltage in which noise can cause unintended high-frequency switching. You can select this feature individually for each I/O pin. The bus-hold output drives no higher than  $V_{CCIO}$  to prevent overdriving signals.

 If you enable the bus-hold feature, the device cannot use the programmable pull-up option. Disable the bus-hold feature when the I/O pin is configured for differential signals. Bus-hold circuitry is not available on dedicated clock pins.

Bus-hold circuitry is only active after configuration. When going into user mode, the bus-hold circuit captures the value on the pin present at the end of configuration.

- For the specific sustaining current for each  $V_{CCIO}$  voltage level driven through the resistor and for the overdrive current used to identify the next driven input level, refer to the *Cyclone IV Device Datasheet* chapter.

## Programmable Pull-Up Resistor

Each Cyclone IV device I/O pin provides an optional programmable pull-up resistor while in user mode. If you enable this feature for an I/O pin, the pull-up resistor holds the output to the  $V_{CCIO}$  level of the output pin's bank.

- If you enable the programmable pull-up resistor, the device cannot use the bus-hold feature. Programmable pull-up resistors are not supported on the dedicated configuration, JTAG, and dedicated clock pins.
- When the optional `DEV_OE` signal drives low, all I/O pins remains tri-stated even with the programmable pull-up option enabled.

## Programmable Delay

The Cyclone IV IOE includes programmable delays to ensure zero hold times, minimize setup times, increase clock-to-output times, and delay the clock input signal.

A path in which a pin directly drives a register may require a programmable delay to ensure zero hold time, whereas a path in which a pin drives a register through combinational logic may not require the delay. Programmable delays minimize setup time. The Quartus II Compiler can program these delays to automatically minimize setup time while providing a zero hold time. Programmable delays can increase the register-to-pin delays for output registers. Each dual-purpose clock input pin provides a programmable delay to the global clock networks.

Table 6–1 shows the programmable delays for Cyclone IV devices.

**Table 6–1. Cyclone IV Devices Programmable Delay Chain**

Programmable Delay	Quartus II Logic Option
Input pin-to-logic array delay	Input delay from pin to internal cells
Input pin-to-input register delay	Input delay from pin to input register
Output pin delay	Delay from output register to output pin
Dual-purpose clock input pin delay	Input delay from dual-purpose clock pin to fan-out destinations

There are two paths in the IOE for an input to reach the logic array. Each of the two paths can have a different delay. This allows you to adjust delays from the pin to the internal logic element (LE) registers that reside in two different areas of the device. You must set the two combinational input delays with the input delay from pin to internal cells logic option in the Quartus II software for each path. If the pin uses the input register, one of the delays is disregarded and the delay is set with the input delay from pin to input register logic option in the Quartus II software.

The IOE registers in each I/O block share the same source for the preset or clear features. You can program preset or clear for each individual IOE, but you cannot use both features simultaneously. You can also program the registers to power-up high or low after configuration is complete. If programmed to power-up low, an asynchronous clear can control the registers. If programmed to power-up high, an asynchronous preset can control the registers. This feature prevents the inadvertent activation of the active-low input of another device upon power-up. If one register in an IOE uses a preset or clear signal, all registers in the IOE must use that same signal if they require preset or clear. Additionally, a synchronous reset signal is available for the IOE registers.

 For more information about the input and output pin delay settings, refer to the *Area and Timing Optimization* chapter in volume 2 of the *Quartus II Handbook*.

## PCI-Clamp Diode

Cyclone IV devices provide an optional PCI-clamp diode enabled input and output for each I/O pin. Dual-purpose configuration pins support the diode in user mode if the specific pins are not used as configuration pins for the selected configuration scheme. For example, if you are using the active serial (AS) configuration scheme, you cannot use the clamp diode on the `ASD0` and `nCS0` pins in user mode. Dedicated configuration pins do not support the on-chip diode.

The PCI-clamp diode is available for the following I/O standards:

- 3.3-V LVTTTL
- 3.3-V LVCMOS
- 3.0-V LVTTTL
- 3.0-V LVCMOS
- 2.5-V LVTTTL/LVCMOS
- PCI
- PCI-X

If the input I/O standard is one of the listed standards, the PCI-clamp diode is enabled by default in the Quartus II software.

## OCT Support

Cyclone IV devices feature OCT to provide I/O impedance matching and termination capabilities. OCT helps prevent reflections and maintain signal integrity while minimizing the need for external resistors in high pin-count ball grid array (BGA) packages. Cyclone IV devices provide I/O driver on-chip impedance matching and  $R_S$  OCT for single-ended outputs and bidirectional pins.

 When using  $R_S$  OCT, programmable current strength is not available.

There are two ways to implement OCT in Cyclone IV devices:

- OCT with calibration
- OCT without calibration

Table 6-2 lists the I/O standards that support impedance matching and series termination.

**Table 6-2. Cyclone IV Device I/O Features Support (Part 1 of 2)**

I/O Standard	IOH/IOL Current Strength Setting (mA) <sup>(1), (9)</sup>		R <sub>S</sub> OCT with Calibration Setting, Ohm (Ω)		R <sub>S</sub> OCT Without Calibration Setting, Ohm (Ω)		Cyclone IV E I/O Banks Support	Cyclone IV GX I/O Banks Support	Slew Rate Option <sup>(6)</sup>	PCI-clamp Diode Support	
	Column I/O	Row I/O	Column I/O	Row I/O <sup>(8)</sup>	Column I/O	Row I/O <sup>(8)</sup>					
3.3-V LVTTTL	4,8	4,8	—	—	—	—	1,2,3,4, 5,6,7,8	3,4,5,6, 7,8,9	—	✓	
3.3-V LVCMOS	2	2	—	—	—	—			—	✓	
3.0-V LVTTTL	4,8,12,16	4,8,12,16	50,25	50,25	50,25	50,25			0,1,2	✓	
3.0-V LVCMOS	4,8,12,16	4,8,12,16	50,25	50,25	50,25	50,25				✓	
3.0-V PCI/PCI-X	—	—	—	—	—	—			—	✓	
2.5-V LVTTTL/LVCMOS	4,8,12,16	4,8,12,16	50,25	50,25	50,25	50,25			—	✓	
1.8-V LVTTTL/LVCMOS	2,4,6,8,10,12,16	2,4,6,8,10,12,16	50,25	50,25	50,25	50,25				—	
1.5-V LVCMOS	2,4,6,8,10,12,16	2,4,6,8,10,12,16	50,25	50,25	50,25	50,25			—	—	
1.2-V LVCMOS	2,4,6,8,10,12	2,4,6,8,10	50,25	50	50,25	50				—	
SSTL-2 Class I	8,12	8,12	50	50	50	50			3,4,5,6, 7,8,9	0,1,2	—
SSTL-2 Class II	16	16	25	25	25	25		—			
SSTL-18 Class I	8,10,12	8,10,12	50	50	50	50		—			
SSTL-18 Class II	12,16	12,16	25	25	25	25		—			
HSTL-18 Class I	8,10,12	8,10,12	50	50	50	50		—			
HSTL-18 Class II	16	16	25	25	25	25		—			
HSTL-15 Class I	8,10,12	8,10,12	50	50	50	50		—			
HSTL-15 Class II	16	16	25	25	25	25		—			
HSTL-12 Class I	8,10,12	8,10	50	50	50	50		4,5,6,7, 8			—
HSTL-12 Class II	14	—	25	—	25	—					3,4,7,8
Differential SSTL-2 Class I <sup>(2), (7)</sup>	8,12	8,12	50	50	50	50		1,2,3,4, 5,6,7,8	3,4,5,6, 7,8	0,1,2	—
Differential SSTL-2 Class II <sup>(2), (7)</sup>	16	16	25	25	25	25	—				
Differential SSTL-18 <sup>(2), (7)</sup>	8,10,12	—	50	—	50	—	—				
Differential HSTL-18 <sup>(2), (7)</sup>	8,10,12	—	50	—	50	—	—				
Differential HSTL-15 <sup>(2), (7)</sup>	8,10,12	—	50	—	50	—	—				
Differential HSTL-12 <sup>(2), (7)</sup>	8,10,12	—	50	—	50	—	3,4,7,8				4,7,8

**Table 6-2. Cyclone IV Device I/O Features Support (Part 2 of 2)**

I/O Standard	IOH/IOL Current Strength Setting (mA) <sup>(1), (9)</sup>		R <sub>S</sub> OCT with Calibration Setting, Ohm (Ω)		R <sub>S</sub> OCT Without Calibration Setting, Ohm (Ω)		Cyclone IV E I/O Banks Support	Cyclone IV GX I/O Banks Support	Slew Rate Option <sup>(6)</sup>	PCI-clamp Diode Support
	Column I/O	Row I/O	Column I/O	Row I/O <sup>(8)</sup>	Column I/O	Row I/O <sup>(8)</sup>				
BLVDS	8,12,16	8,12,16	—	—	—	—	1,2,3,4,5,6,7,8	3,4,5,6,7,8	0,1,2	—
LVDS <sup>(3)</sup>	—	—	—	—	—	—		5,6	—	—
PPDS <sup>(3), (4)</sup>	—	—	—	—	—	—			—	—
RSDS and mini-LVDS <sup>(3), (4)</sup>	—	—	—	—	—	—			—	—
Differential LVPECL <sup>(5)</sup>	—	—	—	—	—	—		3,4,5,6,7,8	—	—

**Notes to Table 6-2:**

- (1) The default current strength setting in the Quartus II software is 50-Ω OCT without calibration for all non-voltage reference and HSTL/SSTL Class I I/O standards. The default setting is 25-Ω OCT without calibration for HSTL/SSTL Class II I/O standards.
- (2) The differential SSTL-18 and SSTL-2, differential HSTL-18, HSTL-15, and HSTL-12 I/O standards are supported only on clock input pins and PLL output clock pins.
- (3) True differential (PPDS, LVDS, mini-LVDS, and RSDS I/O standards) outputs are supported in row I/O banks 1, 2, 5, and 6 only for Cyclone IV E devices and right I/O banks 5 and 6 only for Cyclone IV GX devices. Differential outputs in column I/O banks require an external resistor network.
- (4) This I/O standard is supported for outputs only.
- (5) This I/O standard is supported for clock inputs only.
- (6) The default Quartus II slew rate setting is in bold; **2** for all I/O standards that supports slew rate option.
- (7) Differential SSTL-18, differential HSTL-18, HSTL-15, and HSTL-12 I/O standards do not support Class II output.
- (8) Cyclone IV GX devices only support right I/O pins.
- (9) Altera not only offers current strength that meets the industrial standard specification but also other additional current strengths.



For more details about the differential I/O standards supported in Cyclone IV I/O banks, refer to “High-Speed I/O Interface” on page 6-24.

## On-Chip Series Termination with Calibration

Cyclone IV devices support R<sub>S</sub> OCT with calibration in the top, bottom, and right I/O banks. The R<sub>S</sub> OCT calibration circuit compares the total impedance of the I/O buffer to the external 25-Ω ±1% or 50-Ω ±1% resistors connected to the RUP and RDN pins, and dynamically adjusts the I/O buffer impedance until they match (as shown in [Figure 6-2](#)).

The  $R_S$  shown in Figure 6-2 is the intrinsic impedance of the transistors that make up the I/O buffer.

**Figure 6-2. Cyclone IV Devices  $R_S$  OCT with Calibration**

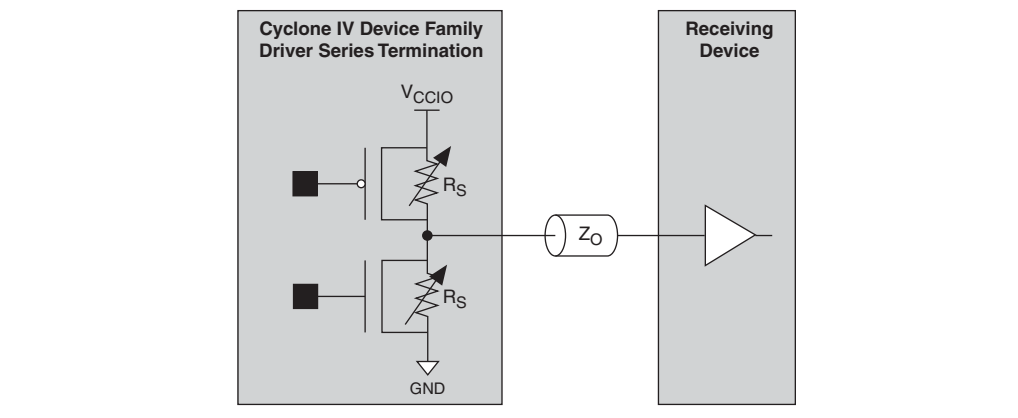

OCT with calibration is achieved using the OCT calibration block circuitry. There is one OCT calibration block in each of I/O banks 2, 4, 5, and 7 for Cyclone IV E devices and I/O banks 4, 5, and 7 for Cyclone IV GX devices. Each calibration block supports each side of the I/O banks. Because there are two I/O banks sharing the same calibration block, both banks must have the same  $V_{CCI_O}$  if both banks enable OCT calibration. If two related banks have different  $V_{CCI_O}$ , only the bank in which the calibration block resides can enable OCT calibration.

Figure 6-10 on page 6-18 shows the top-level view of the OCT calibration blocks placement.

Each calibration block comes with a pair of RUP and RDN pins. When used for calibration, the RUP pin is connected to  $V_{CCI_O}$  through an external  $25\text{-}\Omega \pm 1\%$  or  $50\text{-}\Omega \pm 1\%$  resistor for an  $R_S$  OCT value of  $25\ \Omega$  or  $50\ \Omega$ , respectively. The RDN pin is connected to GND through an external  $25\text{-}\Omega \pm 1\%$  or  $50\text{-}\Omega \pm 1\%$  resistor for an  $R_S$  OCT value of  $25\ \Omega$  or  $50\ \Omega$ , respectively. The external resistors are compared with the internal resistance using comparators. The resultant outputs of the comparators are used by the OCT calibration block to dynamically adjust buffer impedance.

 During calibration, the resistance of the RUP and RDN pins varies.

Figure 6-3 shows the external calibration resistors setup on the RUP and RDN pins and the associated OCT calibration circuitry.

**Figure 6-3. Cyclone IV Devices  $R_S$  OCT with Calibration Setup**

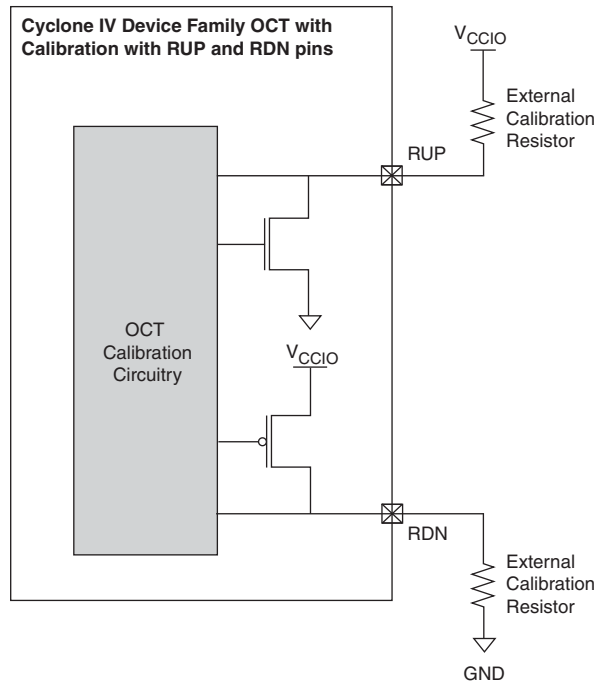

RUP and RDN pins go to a tri-state condition when calibration is completed or not running. These two pins are dual-purpose I/Os and function as regular I/Os if you do not use the calibration circuit.

## On-Chip Series Termination Without Calibration

Cyclone IV devices support driver impedance matching to match the impedance of the transmission line, which is typically 25 or 50  $\Omega$ . When used with the output drivers, OCT sets the output driver impedance to 25 or 50  $\Omega$ . Cyclone IV devices also support I/O driver series termination ( $R_S = 50 \Omega$ ) for SSTL-2 and SSTL-18.

Figure 6-4 shows the single-ended I/O standards for OCT without calibration. The  $R_S$  shown is the intrinsic transistor impedance.

**Figure 6-4. Cyclone IV Devices  $R_S$  OCT Without Calibration**

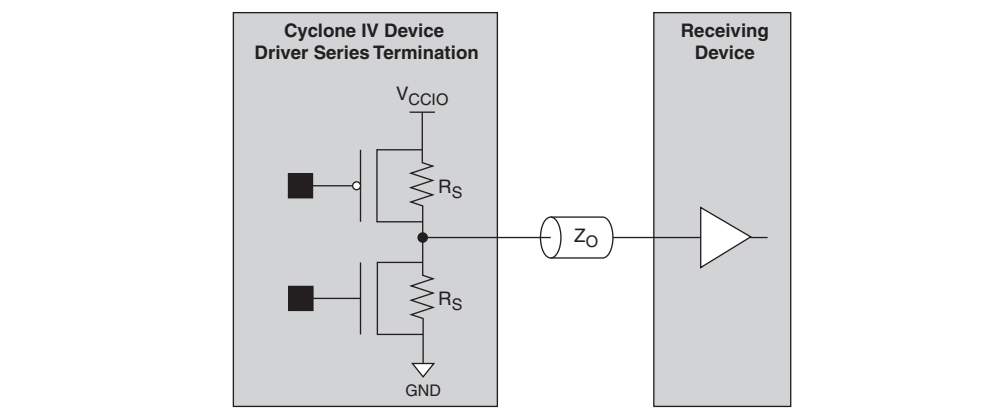

All I/O banks and I/O pins support impedance matching and series termination. Dedicated configuration pins and JTAG pins do not support impedance matching or series termination.

$R_S$  OCT is supported on any I/O bank.  $V_{CCI0}$  and  $V_{REF}$  must be compatible for all I/O pins to enable  $R_S$  OCT in a given I/O bank. I/O standards that support different  $R_S$  values can reside in the same I/O bank as long as their  $V_{CCI0}$  and  $V_{REF}$  do not conflict.

Impedance matching is implemented using the capabilities of the output driver and is subject to a certain degree of variation, depending on the process, voltage, and temperature.

 For more information about tolerance specification, refer to the *Cyclone IV Device Datasheet* chapter.

## I/O Standards

Cyclone IV devices support multiple single-ended and differential I/O standards. Cyclone IV devices support 3.3-, 3.0-, 2.5-, 1.8-, 1.5-, and 1.2-V I/O standards.

Table 6-3 summarizes I/O standards supported by Cyclone IV devices and which I/O pins support them.

**Table 6-3. Cyclone IV Devices Supported I/O Standards and Constraints (Part 1 of 3)**

I/O Standard	Type	Standard Support	$V_{CCI0}$ Level (in V)		Column I/O Pins			Row I/O Pins <sup>(1)</sup>	
			Input	Output	CLK, DQS	PLL_OUT	User I/O Pins	CLK, DQS	User I/O Pins
3.3-V LVTTTL, 3.3-V LVCMOS <sup>(2)</sup>	Single-ended	JESD8-B	3.3/3.0/2.5 <sup>(3)</sup>	3.3	✓	✓	✓	✓	✓
3.0-V LVTTTL, 3.0-V LVCMOS <sup>(2)</sup>	Single-ended	JESD8-B	3.3/3.0/2.5 <sup>(3)</sup>	3.0	✓	✓	✓	✓	✓

**Table 6-3. Cyclone IV Devices Supported I/O Standards and Constraints (Part 2 of 3)**

I/O Standard	Type	Standard Support	V <sub>CCIO</sub> Level (in V)		Column I/O Pins			Row I/O Pins <sup>(1)</sup>	
			Input	Output	CLK, DQS	PLL_OUT	User I/O Pins	CLK, DQS	User I/O Pins
2.5-V LVTTTL / LVCMOS	Single-ended	JESD8-5	3.3/3.0/2.5 <sup>(3)</sup>	2.5	✓	✓	✓	✓	✓
1.8-V LVTTTL / LVCMOS	Single-ended	JESD8-7	1.8/1.5 <sup>(3)</sup>	1.8	✓	✓	✓	✓	✓
1.5-V LVCMOS	Single-ended	JESD8-11	1.8/1.5 <sup>(3)</sup>	1.5	✓	✓	✓	✓	✓
1.2-V LVCMOS <sup>(4)</sup>	Single-ended	JESD8-12A	1.2	1.2	✓	✓	✓	✓	✓
SSTL-2 Class I, SSTL-2 Class II	voltage-referenced	JESD8-9A	2.5	2.5	✓	✓	✓	✓	✓
SSTL-18 Class I, SSTL-18 Class II	voltage-referenced	JESD815	1.8	1.8	✓	✓	✓	✓	✓
HSTL-18 Class I, HSTL-18 Class II	voltage-referenced	JESD8-6	1.8	1.8	✓	✓	✓	✓	✓
HSTL-15 Class I, HSTL-15 Class II	voltage-referenced	JESD8-6	1.5	1.5	✓	✓	✓	✓	✓
HSTL-12 Class I	voltage-referenced	JESD8-16A	1.2	1.2	✓	✓	✓	✓	✓
HSTL-12 Class II <sup>(9)</sup>	voltage-referenced	JESD8-16A	1.2	1.2	✓	✓	✓	—	—
PCI and PCI-X	Single-ended	—	3.0	3.0	✓	✓	✓	✓	✓
Differential SSTL-2 Class I or Class II	Differential <sup>(5)</sup>	JESD8-9A	—	2.5	—	✓	—	—	—
			2.5	—	✓	—	—	✓	—
Differential SSTL-18 Class I or Class II	Differential <sup>(5)</sup>	JESD815	—	1.8	—	✓	—	—	—
			1.8	—	✓	—	—	✓	—
Differential HSTL-18 Class I or Class II	Differential <sup>(5)</sup>	JESD8-6	—	1.8	—	✓	—	—	—
			1.8	—	✓	—	—	✓	—
Differential HSTL-15 Class I or Class II	Differential <sup>(5)</sup>	JESD8-6	—	1.5	—	✓	—	—	—
			1.5	—	✓	—	—	✓	—
Differential HSTL-12 Class I or Class II	Differential <sup>(5)</sup>	JESD8-16A	—	1.2	—	✓	—	—	—
			1.2	—	✓	—	—	✓	—
PPDS <sup>(6)</sup>	Differential	—	—	2.5	—	✓	✓	—	✓
LVDS <sup>(10)</sup>	Differential	ANSI/TIA/EIA-644	2.5	2.5	✓	✓	✓	✓	✓
RSDS and mini-LVDS <sup>(6)</sup>	Differential	—	—	2.5	—	✓	✓	—	✓
BLVDS <sup>(8)</sup>	Differential	—	2.5	2.5	—	—	✓	—	✓

**Table 6-3. Cyclone IV Devices Supported I/O Standards and Constraints (Part 3 of 3)**

I/O Standard	Type	Standard Support	V <sub>CCIO</sub> Level (in V)		Column I/O Pins			Row I/O Pins <sup>(1)</sup>	
			Input	Output	CLK, DQS	PLL_OUT	User I/O Pins	CLK, DQS	User I/O Pins
LVPECL <sup>(7)</sup>	Differential	—	2.5	—	✓	—	—	✓	—

**Notes to Table 6-3:**

- (1) Cyclone IV GX devices only support right I/O pins.
- (2) The PCI-clamp diode must be enabled for 3.3-V/3.0-V LVTTTL/LVCMOS.
- (3) The Cyclone IV architecture supports the MultiVolt I/O interface feature that allows Cyclone IV devices in all packages to interface with I/O systems that have different supply voltages.
- (4) Cyclone IV GX devices do not support 1.2-V V<sub>CCIO</sub> in banks 3 and 9. I/O pins in bank 9 are dual-purpose I/O pins that are used as configuration or GPIO pins. Configuration scheme is not support at 1.2 V, therefore bank 9 can not be powered up at 1.2-V V<sub>CCIO</sub>.
- (5) Differential HSTL and SSTL outputs use two single-ended outputs with the second output programmed as inverted. Differential HSTL and SSTL inputs treat differential inputs as two single-ended HSTL and SSTL inputs and only decode one of them. Differential HSTL and SSTL are only supported on CLK pins.
- (6) PPDS, mini-LVDS, and RSDS are only supported on output pins.
- (7) LVPECL is only supported on clock inputs.
- (8) Bus LVDS (BLVDS) output uses two single-ended outputs with the second output programmed as inverted. BLVDS input uses LVDS input buffer.
- (9) 1.2-V HSTL input is supported at both column and row I/Os regardless of Class I or Class II.
- (10) True LVDS, RSDS, and mini-LVDS I/O standards are supported in left and right I/O pins, while emulated LVDS, RSDS, and mini-LVDS I/O standards are supported in the top, bottom, and right I/O pins.

Cyclone IV devices support PCI and PCI-X I/O standards at 3.0-V V<sub>CCIO</sub>. The 3.0-V PCI and PCI-X I/O are fully compatible for direct interfacing with 3.3-V PCI systems without requiring any additional components. The 3.0-V PCI and PCI-X outputs meet the V<sub>IH</sub> and V<sub>IL</sub> requirements of 3.3-V PCI and PCI-X inputs with sufficient noise margin.

 For more information about the 3.3/3.0/2.5-V LVTTTL & LVCMOS multivolt I/O support, refer to *AN 447: Interfacing Cyclone III and Cyclone IV Devices with 3.3/3.0/2.5-V LVTTTL/LVCMOS I/O Systems*.

## Termination Scheme for I/O Standards

This section describes recommended termination schemes for voltage-referenced and differential I/O standards.

The 3.3-V LVTTTL, 3.0-V LVTTTL and LVCMOS, 2.5-V LVTTTL and LVCMOS, 1.8-V LVTTTL and LVCMOS, 1.5-V LVCMOS, 1.2-V LVCMOS, 3.0-V PCI, and PCI-X I/O standards do not specify a recommended termination scheme per the JEDEC standard

## Voltage-Referenced I/O Standard Termination

Voltage-referenced I/O standards require an input reference voltage ( $V_{REF}$ ) and a termination voltage ( $V_{TT}$ ). The reference voltage of the receiving device tracks the termination voltage of the transmitting device, as shown in Figure 6-5 and Figure 6-6.

Figure 6-5. Cyclone IV Devices HSTL I/O Standard Termination

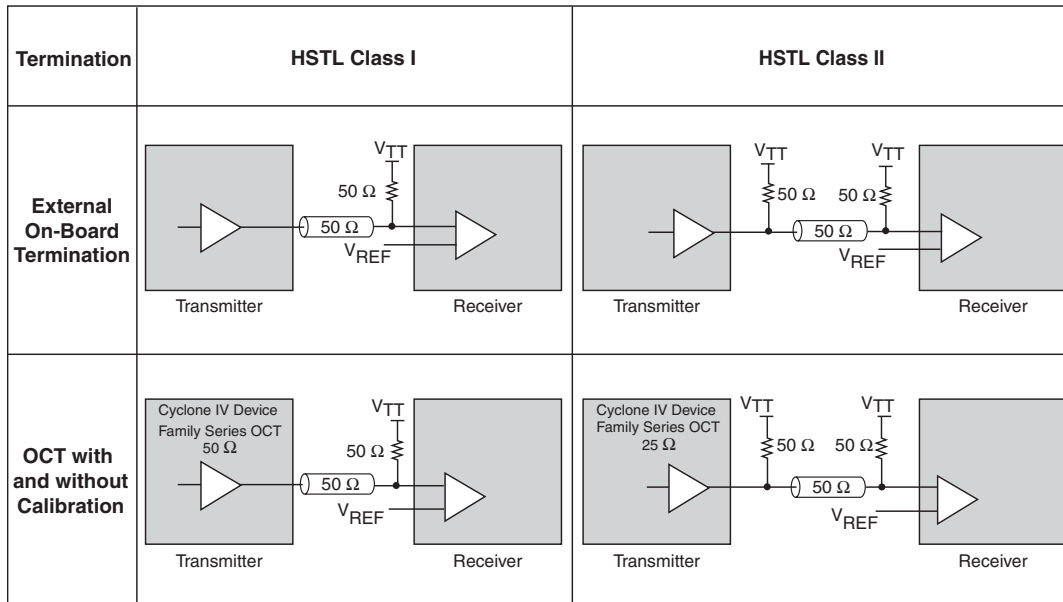
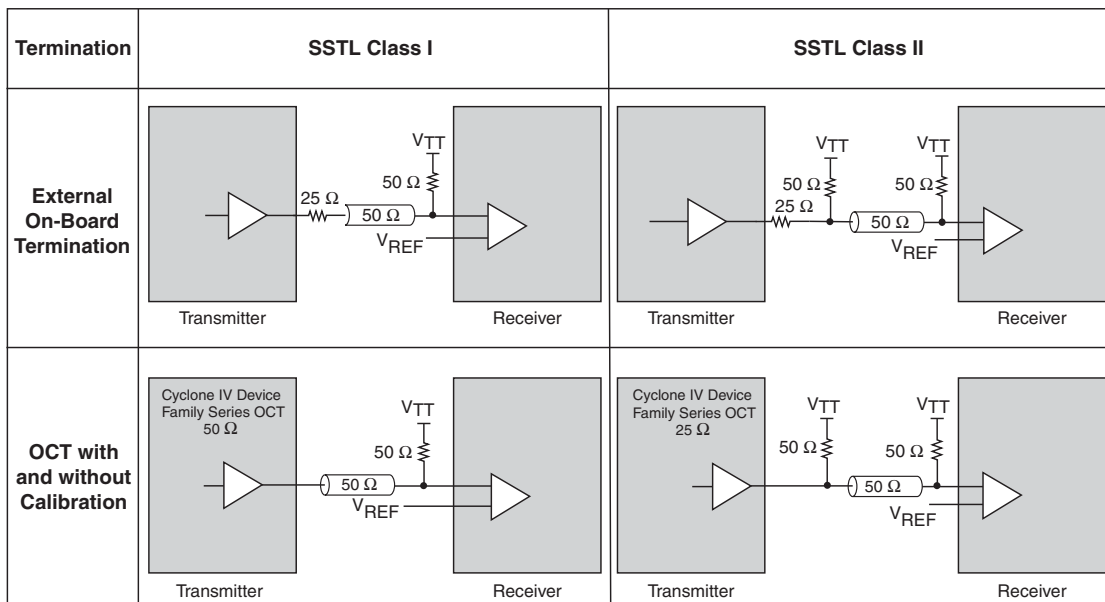

Figure 6-6. Cyclone IV Devices SSTL I/O Standard Termination



## Differential I/O Standard Termination

Differential I/O standards typically require a termination resistor between the two signals at the receiver. The termination resistor must match the differential load impedance of the bus (refer to Figure 6-7 and Figure 6-8).

Cyclone IV devices support differential SSTL-2 and SSTL-18, differential HSTL-18, HSTL-15, and HSTL-12, PPDS, LVDS, RSDS, mini-LVDS, and differential LVPECL.

Figure 6-7. Cyclone IV Devices Differential HSTL I/O Standard Class I and Class II Interface and Termination

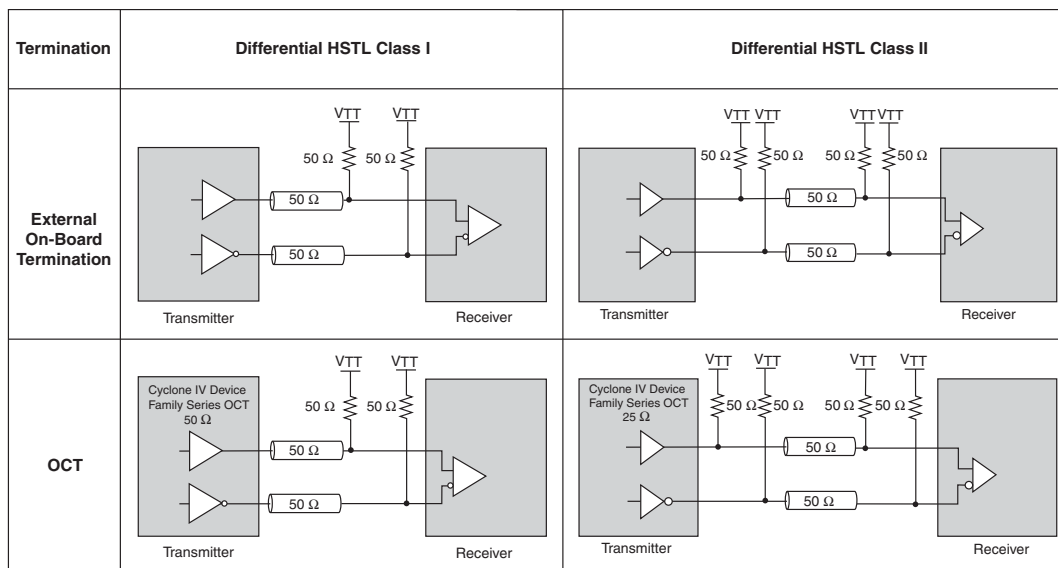
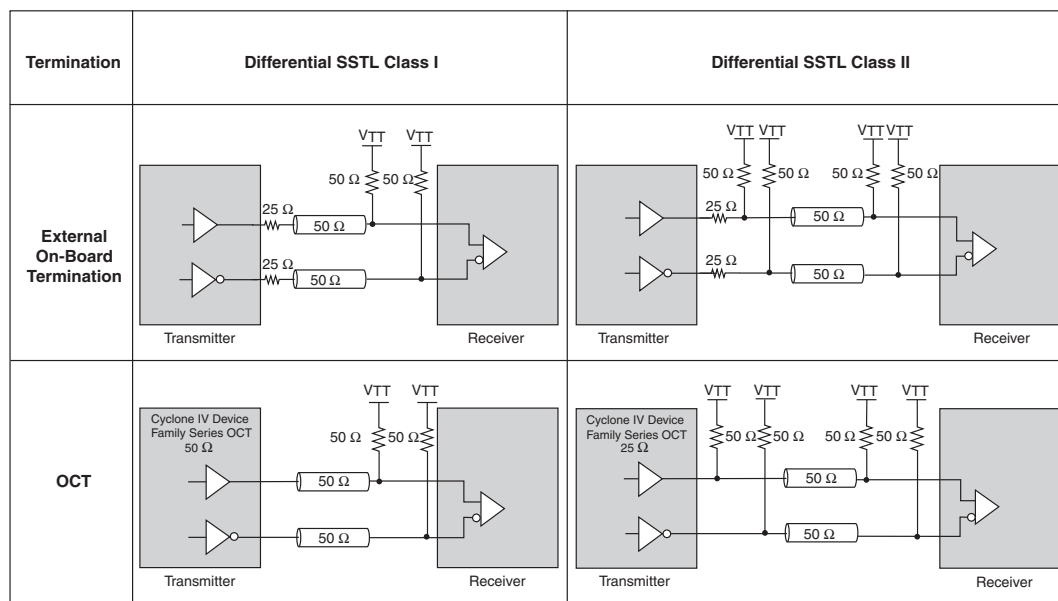

Figure 6-8. Cyclone IV Devices Differential SSTL I/O Standard Class I and Class II Interface and Termination <sup>(1)</sup>



Note to Figure 6-8:

(1) Only Differential SSTL-2 I/O standard supports Class II output.

## I/O Banks

I/O pins on Cyclone IV devices are grouped together into I/O banks. Each bank has a separate power bus.

Cyclone IV E devices have eight I/O banks, as shown in [Figure 6-9](#). Each device I/O pin is associated with one I/O bank. All single-ended I/O standards are supported in all banks except HSTL-12 Class II, which is only supported in column I/O banks. All differential I/O standards are supported in all banks. The only exception is HSTL-12 Class II, which is only supported in column I/O banks.

Cyclone IV GX devices have up to ten I/O banks and two configuration banks, as shown in [Figure 6-10 on page 6-18](#) and [Figure 6-11 on page 6-19](#). The Cyclone IV GX configuration I/O bank contains three user I/O pins that can be used as normal user I/O pins if they are not used in configuration modes. Each device I/O pin is associated with one I/O bank. All single-ended I/O standards are supported except HSTL-12 Class II, which is only supported in column I/O banks. All differential I/O standards are supported in top, bottom, and right I/O banks. The only exception is HSTL-12 Class II, which is only supported in column I/O banks.

The entire left side of the Cyclone IV GX devices contain dedicated high-speed transceiver blocks for high speed serial interface applications. There are a total of 2, 4, and 8 transceiver channels for Cyclone IV GX devices, depending on the density and package of the device. For more information about the transceiver channels supported, refer to [Figure 6-10 on page 6-18](#) and [Figure 6-11 on page 6-19](#).

Figure 6-9 shows the overview of Cyclone IV E I/O banks.

Figure 6-9. Cyclone IV E I/O Banks (1), (2)

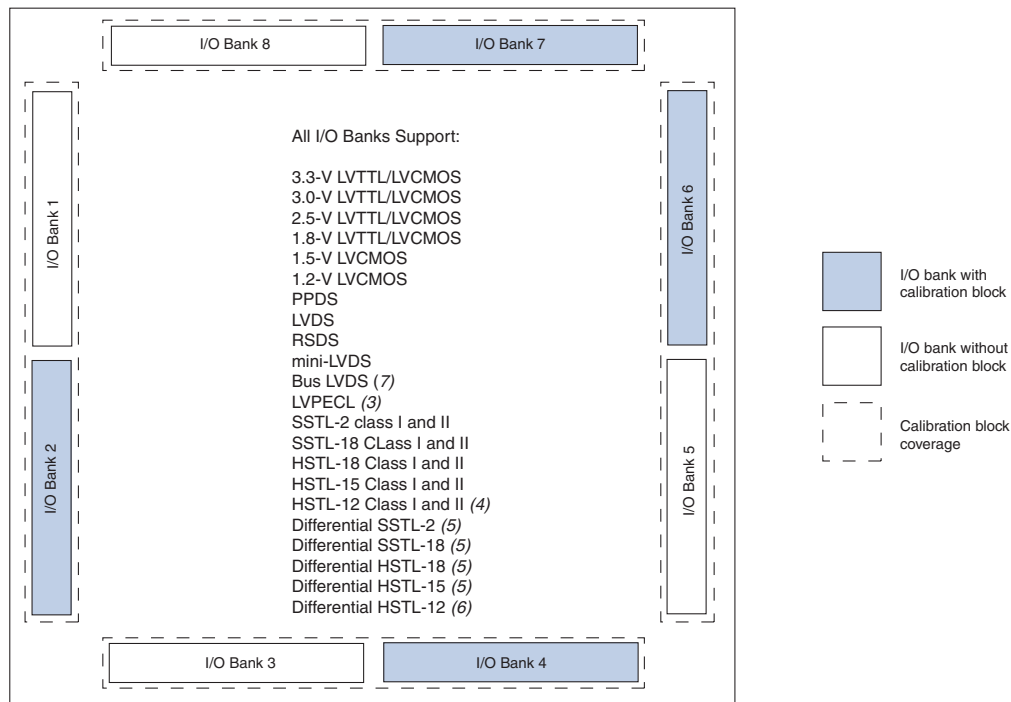

**Notes to Figure 6-9:**

- (1) This is a top view of the silicon die. This is only a graphical representation. For exact pin locations, refer to the pin list and the Quartus II software.
- (2) True differential (PPDS, LVDS, mini-LVDS, and RSDS I/O standards) outputs are supported in row I/O banks 1, 2, 5, and 6 only. External resistors are needed for the differential outputs in column I/O banks.
- (3) The LVPECL I/O standard is only supported on clock input pins. This I/O standard is not supported on output pins.
- (4) The HSTL-12 Class II is supported in column I/O banks 3, 4, 7, and 8 only.
- (5) The differential SSTL-18 and SSTL-2, differential HSTL-18, and HSTL-15 I/O standards are supported only on clock input pins and phase-locked loops (PLLs) output clock pins. Differential SSTL-18, differential HSTL-18, and HSTL-15 I/O standards do not support Class II output.
- (6) The differential HSTL-12 I/O standard is only supported on clock input pins and PLL output clock pins. Differential HSTL-12 Class II is supported only in column I/O banks 3, 4, 7, and 8.
- (7) BLVDS output uses two single-ended outputs with the second output programmed as inverted. BLVDS input uses true LVDS input buffer.

Figure 6–10 and Figure 6–11 show the overview of Cyclone IV GX I/O banks.

Figure 6–10. Cyclone IV GX I/O Banks for EP4CGX15, EP4CGX22, and EP4CGX30 (1), (2), (9)

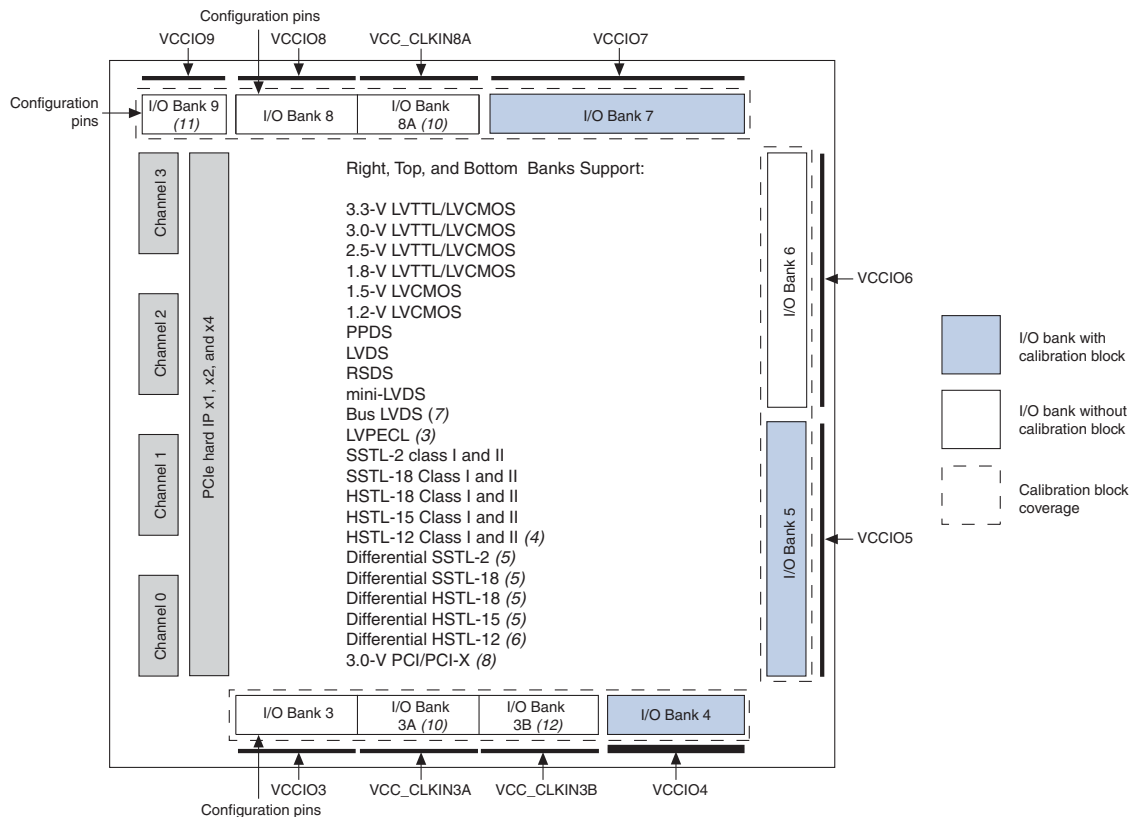

#### Notes to Figure 6–10:

- (1) This is a top view of the silicon die. For exact pin locations, refer to the pin list and the Quartus II software. Channels 2 and 3 are not available in EP4CGX15 and F169 package type in EP4CGX22 and EP4CGX30 devices.
- (2) True differential (PPDS, LVDS, mini-LVDS, and RSQS I/O standards) outputs are supported in row I/O banks 5 and 6 only. External resistors are needed for the differential outputs in column I/O banks.
- (3) The LVPECL I/O standard is only supported on clock input pins. This I/O standard is not supported on output pins.
- (4) The HSTL-12 Class II is supported in column I/O banks 4, 7, and 8.
- (5) The differential SSTL-18 and SSTL-2, differential HSTL-18, and HSTL-15 I/O standards are supported only on clock input pins and phase-locked loops (PLLs) output clock pins. PLL output clock pins do not support Class II interface type of differential SSTL-18, HSTL-18, HSTL-15, and HSTL-12 I/O standards.
- (6) The differential HSTL-12 I/O standard is only supported on clock input pins and PLL output clock pins. Differential HSTL-12 Class II is supported only in column I/O banks 4, 7, and 8.
- (7) BLVDS output uses two single-ended outputs with the second output programmed as inverted. BLVDS input uses the LVDS input buffer.
- (8) The PCI-X I/O standard does not meet the IV curve requirement at the linear region.
- (9) The OCT block is located in the shaded banks 4, 5, and 7.
- (10) There are two dedicated clock input I/O banks (I/O bank 3A and I/O bank 8A) that can be used for either high-speed serial interface (HSSI) input reference clock pins or clock input pins.
- (11) There are dual-purpose I/O pins in bank 9. If input pins with  $V_{REF}$  I/O standards are used on these dual-purpose I/O pins during user mode, they share the  $V_{REF}$  pin in bank 8. These dual-purpose I/O pins in bank 9 when used in user mode also support  $R_S$  OCT without calibration and they share the OCT block with bank 8.
- (12) There are four dedicated clock input in I/O bank 3B for the EP4CGX30F484 device that can be used for either HSSI input reference clock pins or clock input pins.

Figure 6-11. Cyclone IV GX I/O Banks for EP4CGX50, EP4CGX75, EP4CGX110, and EP4CGX150 (1), (2), (9)

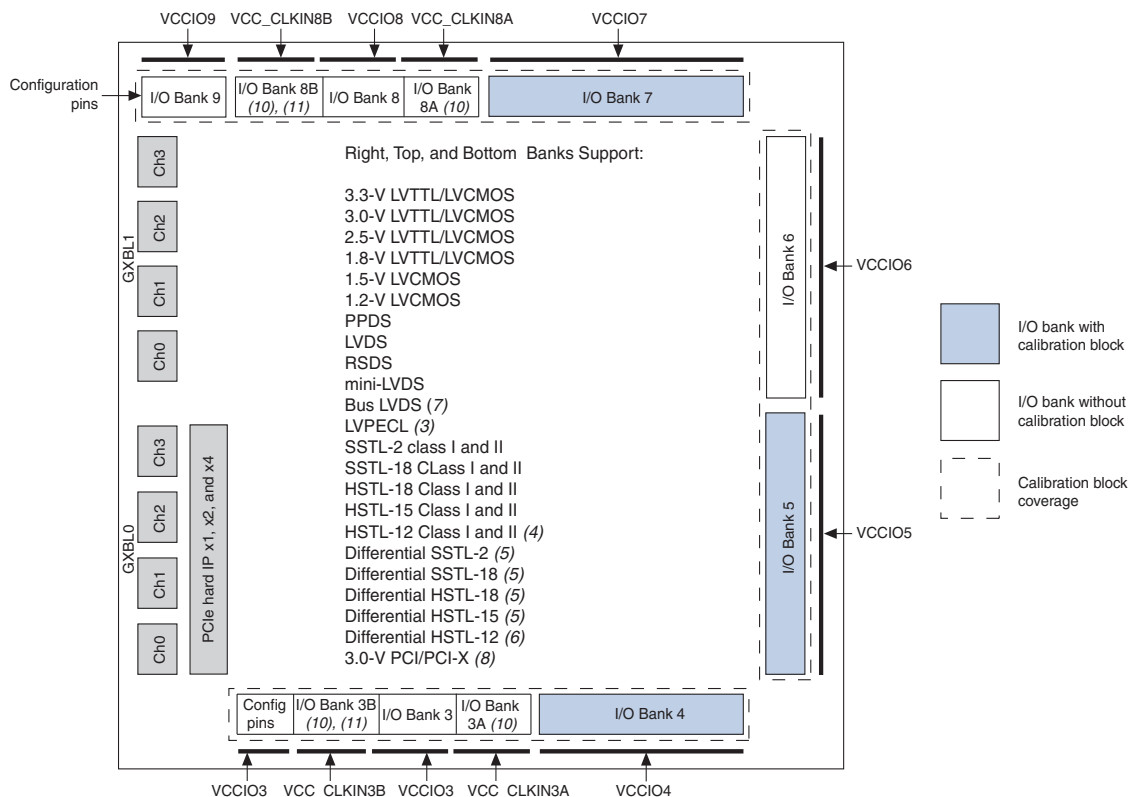

Notes to Figure 6-11:

- (1) This is a top view of the silicon die. For exact pin locations, refer to the pin list and the Quartus II software.
- (2) True differential (PPDS, LVDS, mini-LVDS, and RSQS I/O standards) outputs are supported in row I/O banks 5 and 6 only. External resistors are needed for the differential outputs in column I/O banks.
- (3) The LVPECL I/O standard is only supported on clock input pins. This I/O standard is not supported on output pins.
- (4) The HSTL-12 Class II is supported in column I/O banks 4, 7, and 8.
- (5) The differential SSTL-18 and SSTL-2, differential HSTL-18, and HSTL-15 I/O standards are supported only on clock input pins and phase-locked loops (PLLs) output clock pins. PLL output clock pins do not support Class II interface type of differential SSTL-18, HSTL-18, HSTL-15, and HSTL-12 I/O standards.
- (6) The differential HSTL-12 I/O standard is only supported on clock input pins and PLL output clock pins. Differential HSTL-12 Class II is supported only in column I/O banks 4, 7, and 8.
- (7) BLVDS output uses two single-ended outputs with the second output programmed as inverted. BLVDS input uses the LVDS input buffer.
- (8) The PCI-X I/O standard does not meet the IV curve requirement at the linear region.
- (9) The OCT block is located in the shaded banks 4, 5, and 7.
- (10) The dedicated clock input I/O banks 3A, 3B, 8A, and 8B can be used either for HSSI input reference clock pins or clock input pins.
- (11) Single-ended clock input support is available for dedicated clock input I/O banks 3B and 8B.

Each Cyclone IV I/O bank has a  $V_{REF}$  bus to accommodate voltage-referenced I/O standards. Each  $V_{REF}$  source for its  $V_{REF}$  group. If you use a  $V_{REF}$  group for voltage-referenced I/O standards, connect the  $V_{REF}$  to the appropriate voltage level. If you do not use all the  $V_{REF}$  groups in the I/O bank for voltage-referenced I/O standards, you can use the  $V_{REF}$  pin in the unused voltage-referenced groups as regular I/O pins. For example, if you have 4  $V_{REF}$  pins in I/O bank 1 and they are all placed in the  $V_{REFB1N}[0]$  group,  $V_{REFB1N}[0]$  must be powered by the  $V_{REF}$  source. The remaining  $V_{REFB1N}[1..3]$  pins (if available) are used as I/O pins. If multiple  $V_{REF}$  groups are used in an I/O bank,  $V_{REF}$  pins must all be powered by the same voltage level because the  $V_{REF}$  pins are shorted together within the I/O bank.



When  $V_{REF}$  pins are used as regular I/Os, they have higher pin capacitance than regular user I/O pins because the timing of the pins is affected by the timing of the  $V_{REF}$  pins used as inputs and outputs.



For more information about  $V_{REF}$  pin capacitance, refer to the pin capacitance section in the [Cyclone IV](#)



For information about how to identify  $V_{REF}$  groups, refer to the Cyclone IV **Device Pin-Out** files or the [Pin-Out](#) tool.

[Table 6-4](#) and [Table 6-5](#) summarize the number of  $V_{REF}$  pins in each I/O bank for the Cyclone IV devices.

**Table 6-4. Number of  $V_{REF}$  Pins Per I/O Bank for Cyclone IV E Devices (Part 1 of 2)**

Device I/O Bank	EP4CE6			EP4CE15						EP4CE22			EP4CE30			EP4CE40			EP4CE55							
	144-EQPF	256-UBGA	256-FBGA	144-EQPF	164-MBGA	256-MBGA	256-UBGA	256-FBGA	484-FBGA	144-EQPF	256-UBGA	256-FBGA	324-FBGA	484-FBGA	780-FBGA	324-FBGA	484-UBGA	484-FBGA	780-FBGA	484-UBGA	484-FBGA	780-FBGA				
1	1	1	1	2	2	2	2	2	2	1	1	1	4	4	4	4	4	4	4	4	4	4	2	2	2	
2	1	1	1	2	2	2	2	2	2	1	1	1	4	4	4	4	4	4	4	4	4	4	4	2	2	2
3	1	1	1	2	2	2	2	2	2	1	1	1	4	4	4	4	4	4	4	4	4	4	4	2	2	2
4	1	1	1	2	2	2	2	2	2	1	1	1	4	4	4	4	4	4	4	4	4	4	4	2	2	2
5	1	1	1	2	2	2	2	2	2	1	1	1	4	4	4	4	4	4	4	4	4	4	4	2	2	2
6	1	1	1	2	2	2	2	2	2	1	1	1	4	4	4	4	4	4	4	4	4	4	4	2	2	2
7	1	1	1	2	2	2	2	2	2	1	1	1	4	4	4	4	4	4	4	4	4	4	4	2	2	2

**Table 6-4. Number of VREF Pins Per I/O Bank for Cyclone IV E Devices (Part 2 of 2)**

Device	EP4CE6			EP4CE10			EP4CE15					EP4CE22			EP4CE30			EP4CE40				EP4CE55					
I/O Bank (1)	144-EQPF	256-UBGA	256-FBGA	144-EQPF	256-UBGA	256-FBGA	164-MBGA	256-MBGA	256-UBGA	256-FBGA	484-FBGA	144-EQPF	256-UBGA	256-FBGA	324-FBGA	484-FBGA	780-FBGA	324-FBGA	484-UBGA	484-FBGA	780-FBGA	484-UBGA	484-FBGA	780-FBGA	484-UBGA	484-FBGA	780-FBGA
8	1	1	1	1	1	1	2	2	2	2	2	1	1	1	1	4	4	4	4	4	4	4	4	4	2	2	2

Note to Table 6-4:

(1) User I/O pins are used as inputs or outputs; clock input pins are used as inputs only; clock output pins are used as output only.

**Table 6-5. Number of VREF Pins Per I/O Bank for Cyclone IV GX Devices**

Device	4CGX15	4CGX22		4CGX30			4CGX50		4CGX75		4CGX110			
I/O Bank (1)	169-FBGA	169-FBGA	324-FBGA	169-FBGA	324-FBGA	484-FBGA	484-FBGA	484-FBGA	672-FBGA	484-FBGA	672-FBGA	484-FBGA	672-FBGA	896-FBGA
3	1	1	1	1	1	3	3	3	3	3	3	3	3	
4	1	1	1	1	1	3	3	3	3	3	3	3	3	
5	1	1	1	1	1	3	3	3	3	3	3	3	3	
6	1	1	1	1	1	3	3	3	3	3	3	3	3	
7	1	1	1	1	1	3	3	3	3	3	3	3	3	
8 (2)	1	1	1	1	1	3	3	3	3	3	3	3	3	

Notes to Table 6-5:

(1) User I/O pins are used as inputs or outputs; clock input pins are used as inputs only; clock output pins are used as output only.

(2) Bank 9 does not have VREF pin. If input pins with VREF I/O standards are used in bank 9 during user mode, it shares the VREF pin in bank 8.

Each Cyclone IV I/O bank has its own VCCIO pins. Each I/O bank can support only one VCCIO setting for 2.5, 3.0, or 3.3 V. Any number of supported single-ended or differential standards can be simultaneous I/O bank, as long as they use the same VCCIO levels for input and output pins.

When designing LVTTTL/LVCMOS inputs with Cyclone IV devices, refer to the following guidelines:

- All pins accept input voltage ( $V_I$ ) up to a maximum limit (3.6 V), as stated in the recommended operating conditions provided in the *Cyclone IV Device Datasheet* chapter.
- Whenever the input level is higher than the bank  $V_{CCIO}$ , expect higher leakage current.
- The LVTTTL/LVCMOS I/O standard input pins can only meet the  $V_{IH}$  and  $V_{IL}$  levels according to bank voltage level.

Voltage-referenced standards are supported in an I/O bank using any number of single-ended or differential standards, as long as they use the same  $V_{REF}$  and  $V_{CCIO}$  values. For example, if you choose to implement both SSTL-2 and SSTL-18 in your Cyclone IV devices, I/O pins using these standards—because they require different  $V_{REF}$  values—must be in different banks from each other. However, the same I/O bank can support SSTL-2 and 2.5-V LVCMOS with the  $V_{CCIO}$  set to 2.5 V and the  $V_{REF}$  set to 1.25 V.

 When using Cyclone IV devices as a receiver in 3.3-, 3.0-, or 2.5-V LVTTTL/LVCMOS systems, you are responsible for managing overshoot or undershoot to stay in the absolute maximum ratings and the recommended operating conditions, provided in the *Cyclone IV Device Datasheet* chapter.

 The PCI clamping diode is enabled by default in the Quartus II software for input signals with bank  $V_{CCIO}$  at 2.5, 3.0, or 3.3 V.

## High-Speed Differential Interfaces

Cyclone IV devices can send and receive data through LVDS signals. For the LVDS transmitter and receiver, the input and output pins of Cyclone IV devices support serialization and deserialization through internal logic.

The BLVDS extends the benefits of LVDS to multipoint applications such as bidirectional backplanes. The loading effect and the need to terminate the bus at both ends for multipoint applications require BLVDS to drive out a higher current than LVDS to produce a comparable voltage swing. All the I/O banks of Cyclone IV devices support BLVDS for user I/O pins.

The RSDS and mini-LVDS standards are derivatives of the LVDS standard. The RSDS and mini-LVDS I/O standards are similar in electrical characteristics to LVDS, but have a smaller voltage swing and therefore provide increased power benefits and reduced electromagnetic interference (EMI).

The PPDS standard is the next generation of the RSDS standard introduced by National Semiconductor Corporation. Cyclone IV devices meet the National Semiconductor Corporation PPDS Interface Specification and support the PPDS standard for outputs only. All the I/O banks of Cyclone IV devices support the PPDS standard for output pins only.

The LVDS standard does not require an input reference voltage, but it does require a 100- $\Omega$  termination resistor between the two signals at the input buffer. An external resistor network is required on the transmitter side for the top and bottom I/O banks.

## External Memory Interfacing

Cyclone IV devices support I/O standards required to interface with a broad range of external memory interfaces, such as DDR SDRAM, DDR2 SDRAM, and QDR II SRAM.

-  For more information about Cyclone IV devices external memory interface support, refer to the *External Memory Interfaces in Cyclone IV Devices* chapter.

## Pad Placement and DC Guidelines

You can use the Quartus II software to validate your pad and pin placement.

### Pad Placement

Altera recommends that you create a Quartus II design, enter your device I/O assignments and compile your design to validate your pin placement. The Quartus II software checks your pin connections with respect to the I/O assignment and placement rules to ensure proper device operation. These rules depend on device density, package, I/O assignments, voltage assignments and other factors that are not fully described in this chapter.

-  For more information about how the Quartus II software checks I/O restrictions, refer to the *I/O Management* chapter in volume 2 of the *Quartus II Handbook*.

### DC Guidelines

For the Quartus II software to automatically check for illegally placed pads according to the DC guidelines, set the DC current sink or source value to **Electromigration Current** assignment on each of the output pins that are connected to the external resistive load.

The programmable current strength setting has an impact on the amount of DC current that an output pin can source or sink. Determine if the current strength setting is sufficient for the external resistive load condition on the output pin.

## Clock Pins Functionality

Cyclone IV clock pins have multiple purposes, as per listed:

- CLK pins—Input support for single-ended and voltage-referenced standards. For I/O standard support, refer to [Table 6-3 on page 6-11](#).
- DIFFCLK pins—Input support for differential standards. For I/O standard support, refer to [Table 6-3 on page 6-11](#). When used as DIFFCLK pins, DC or AC coupling can be used depending on the interface requirements and external termination is required. For more information, refer to [“High-Speed I/O Standards Support” on page 6-28](#).
- REFCLK pins—Input support for high speed differential reference clocks used by the transceivers in Cyclone IV GX devices. For I/O support, coupling, and termination requirements, refer to [Table 6-10 on page 6-29](#).

## High-Speed I/O Interface

Cyclone IV E I/Os are separated into eight I/O banks, as shown in [Figure 6-9 on page 6-17](#). Cyclone IV GX I/Os are separated into six user I/O banks with the left side of the device as the transceiver block, as shown in [Figure 6-10 on page 6-18](#). Each bank has an independent power supply. True output drivers for LVDS, RSDS, mini-LVDS, and PPDS are on the right I/O banks. On the Cyclone IV E row I/O banks and the Cyclone IV GX right I/O banks, some of the differential pin pairs (p and n pins) of the true output drivers are not located on adjacent pins. In these cases, a power pin is located between the p and n pins. These I/O standards are also supported on all I/O banks using two single-ended output with the second output programmed as inverted, and an external resistor network. True input buffers for these I/O standards are supported on the top, bottom, and right I/O banks except for I/O bank 9.

Table 6-6 and Table 6-7 summarize which I/O banks support these I/O standards in the Cyclone IV device family.

**Table 6-6. Differential I/O Standards Supported in Cyclone IV E I/O Banks**

Differential I/O Standards	I/O Bank Location	External Resistor Network at Transmitter	Transmitter (TX)	Receiver (RX)
LVDS	1,2,5,6	Not Required	✓	✓
	All	Three Resistors		
RSDS	1,2,5,6	Not Required	✓	—
	3,4,7,8	Three Resistors		
	All	Single Resistor		
mini-LVDS	1,2,5,6	Not Required	✓	—
	All	Three Resistors		
PPDS	1,2,5,6	Not Required	✓	—
	All	Three Resistors		
BLVDS <sup>(1)</sup>	All	Single Resistor	✓	✓
LVPECL <sup>(2)</sup>	All	—	—	✓
Differential SSTL-2 <sup>(3)</sup>	All	—	✓	✓
Differential SSTL-18 <sup>(3)</sup>	All	—	✓	✓
Differential HSTL-18 <sup>(3)</sup>	All	—	✓	✓
Differential HSTL-15 <sup>(3)</sup>	All	—	✓	✓
Differential HSTL-12 <sup>(3), (4)</sup>	All	—	✓	✓

**Notes to Table 6-6:**

- (1) Transmitter and Receiver  $f_{MAX}$  depend on system topology and performance requirement.
- (2) The LVPECL I/O standard is only supported on dedicated clock input pins.
- (3) The differential SSTL-2, SSTL-18, HSTL-18, HSTL-15, and HSTL-12 I/O standards are only supported on clock input pins and PLL output clock pins. PLL output clock pins do not support Class II interface type of differential SSTL-18, HSTL-18, HSTL-15, and HSTL-12 I/O standards.
- (4) Differential HSTL-12 Class II is supported only in column I/O banks.

**Table 6-7. Differential I/O Standards Supported in Cyclone IV GX I/O Banks**

Differential I/O Standards	I/O Bank Location	External Resistor Network at Transmitter	Transmitter (TX)	Receiver (RX)
LVDS	5,6	Not Required	✓	✓
	3,4,5,6,7,8	Three Resistors		
RSDS	5,6	Not Required	✓	—
	3,4,7,8	Three Resistors		
	3,4,5,6,7,8	Single Resistor		
mini-LVDS	5,6	Not Required	✓	—
	3,4,5,6,7,8	Three Resistors		
PPDS	5,6	Not Required	✓	—
	3,4,5,6,7,8	Three Resistors		
BLVDS <sup>(1)</sup>	3,4,5,6,7,8	Single Resistor	✓	✓
LVPECL <sup>(2)</sup>	3,4,5,6,7,8	—	—	✓
Differential SSTL-2 <sup>(3)</sup>	3,4,5,6,7,8	—	✓	✓
Differential SSTL-18 <sup>(3)</sup>	3,4,5,6,7,8	—	✓	✓
Differential HSTL-18 <sup>(3)</sup>	3,4,5,6,7,8	—	✓	✓
Differential HSTL-15 <sup>(3)</sup>	3,4,5,6,7,8	—	✓	✓
Differential HSTL-12 <sup>(3)</sup>	4,5,6,7,8	—	✓	✓

**Notes to Table 6-7:**

- (1) Transmitter and Receiver  $f_{MAX}$  depend on system topology and performance requirement.
- (2) The LVPECL I/O standard is only supported on dedicated clock input pins.
- (3) The differential SSTL-2, SSTL-18, HSTL-18, HSTL-15, and HSTL-12 I/O standards are only supported on clock input pins and PLL output clock pins. PLL output clock pins do not support Class II interface type of differential SSTL-18, HSTL-18, HSTL-15, and HSTL-12 I/O standards.

You can use I/O pins and internal logic to implement a high-speed differential interface in Cyclone IV devices. Cyclone IV devices do not contain dedicated serialization or deserialization circuitry. Therefore, shift registers, internal phase-locked loops (PLLs), and I/O cells are used to perform serial-to-parallel conversions on incoming data and parallel-to-serial conversion on outgoing data. The differential interface data serializers and deserializers (SERDES) are automatically constructed in the core logic elements (LEs) with the Quartus II software ALTLVDS megafunction.

Table 6-8 and Table 6-9 summarize the total number of supported row and column differential channel device family.

**Table 6-8. Cyclone IV E I/O and Differential Channel Count**

Device	EP4CE6			EP4CE10			EP4CE15						EP4CE22			EP4CE30			EP4CE40				EP4CE55						
Numbers of Differential Channels <sup>(1), (2)</sup>	144-EQPF	256-UBGA	256-FBGA	144-EQPF	256-UBGA	256-FBGA	144-EQPF	256-UBGA	256-FBGA	144-EQPF	256-UBGA	256-FBGA	144-EQPF	256-UBGA	256-FBGA	324-FBGA	484-UBGA	484-FBGA	780-FBGA	324-FBGA	484-UBGA	484-FBGA	780-FBGA	484-UBGA	484-FBGA	780-FBGA	484-UBGA	484-FBGA	780-FBGA
User I/O <sup>(3)</sup>	91	179	179	91	179	179	81	89	165	165	165	343	79	153	153	193	328	328	532	193	328	328	532	324	328	328	532	324	371
User I/O Banks	8	8	8	8	8	8	8	8	8	8	8	8	8	8	8	8	8	8	8	8	8	8	8	8	8	8	8	8	8
LVDS <sup>(4), (6)</sup>	8	23	23	8	23	23	6	8	21	21	21	67	7	20	20	30	60	112	30	60	60	112	30	60	60	112	62	70	
Emulated LVDS <sup>(5), (6)</sup>	13	43	43	13	43	43	12	13	32	32	32	70	10	32	32	38	64	112	38	64	64	112	38	64	64	70	90	90	

**Notes to Table 6-8:**

- (1) User I/O pins are used as inputs or outputs; clock input pins are used as inputs only; clock output pins are used as output only.
- (2) For differential pad placement guidelines, refer to "Pad Placement" on page 6-23.
- (3) The I/O pin count includes all GPIOs, dedicated clock pins, and dual-purpose configuration pins. Dedicated configuration pins are not included in the pin count.
- (4) The true LVDS count includes all LVDS I/O pairs, differential clock input and clock output pins in row I/O banks 1, 2, 5, and 6.
- (5) The emulated LVDS count includes all LVDS I/O pairs, differential clock input and clock output pins in column I/O banks 3, 4, 7, and 8.
- (6) LVDS input and output buffers are sharing the same p and n pins. One LVDS I/O channel can only be either transmitter or receiver at a time.

**Table 6-9. Cyclone IV GX I/O, Differential, and XCVRs Channel Count**

Device	4CGX15			4CGX22			4CGX30			4CGX50		4CGX75			4CGX110			4CGX150		
	169-FBGA	169-FBGA	324-FBGA	169-FBGA	324-FBGA	484-FBGA	484-FBGA	672-FBGA	484-FBGA	672-FBGA	484-FBGA	672-FBGA	484-FBGA	672-FBGA	896-FBGA	484-FBGA	672-FBGA	896-FBGA		
User I/O <sup>(3)</sup>	72	72	150	72	150	290	290	310	290	310	270	393	475	270	393	475				
User I/O banks	9 <sup>(4)</sup>	9 <sup>(4)</sup>	9 <sup>(4)</sup>	9 <sup>(4)</sup>	9 <sup>(4)</sup>	11 <sup>(5)</sup>	11 <sup>(5), (6)</sup>	11 <sup>(5), (6)</sup>	11 <sup>(5), (6)</sup>	11 <sup>(5), (6)</sup>	11 <sup>(5), (6)</sup>	11 <sup>(5), (6)</sup>	11 <sup>(5), (6)</sup>	11 <sup>(5), (6)</sup>	11 <sup>(5), (6)</sup>	11 <sup>(5), (6)</sup>				
LVDS <sup>(7), (9)</sup>	9	9	16	9	16	45	45	51	45	51	38	52	63	38	52	63				
Emulated LVDS <sup>(8), (9)</sup>	16	16	48	16	48	85	85	89	85	89	82	129	157	82	129	157				
XCVRs	2	2	4	2	4	4	4	8	4	8	4	8	8	4	8	8				

**Notes to Table 6-9:**

- (1) User I/O pins are used as inputs or outputs; clock input pins are used as inputs only; clock output pins are used as outputs only.
- (2) For differential pad placement guidelines, refer to “Pad Placement” on page 6-23.
- (3) The I/O pin count includes all GPIOs, dedicated clock pins, and dual-purpose configuration pins. Transceivers pins and dedicated configuration pins are not included in the pin count.
- (4) Includes one configuration I/O bank and two dedicated clock input I/O banks for HSSI input reference clock.
- (5) Includes one configuration I/O bank and four dedicated clock input I/O banks for HSSI input reference clock.
- (6) Single-ended clock input support is available for dedicated clock input I/O banks 3B (pins CLKIO20 and CLKIO22) and 8B (pins CLKIO17 and CLKIO19).
- (7) The true LVDS count includes all LVDS I/O pairs, differential clock input and clock output pins in right I/O banks 5 and 6.
- (8) The emulated LVDS count includes all LVDS I/O pairs, differential clock input and clock output pins in column I/O banks 3, 4, 7, and 8.
- (9) LVDS input and output buffers are sharing the same p and n pins. One LVDS I/O channel can only be either transmitter or receiver at a time.

## High-Speed I/O Standards Support

This section provides information about the high-speed I/O standards and the HSSI input reference clock supported in Cyclone IV devices.

### High Speed Serial Interface (HSSI) Input Reference Clock Support

Cyclone IV GX devices support the same I/O features for GPIOs with additional new features where current I/O banks 3A and 8A consist of dual-purpose clock input pins (CLKIN) and 3B and 8B consist of dedicated CLKIN that can be used to support the high-speed transceiver input reference clock (REFCLK) features on top of the general-purpose clock input function.

The EP4CGX15, EP4CGX22, and EP4CGX30 devices contain two pairs of CLKIN/REFCLK pins located in I/O banks 3A and 8A. I/O banks 3B and 8B are not available in EP4CGX15, EP4CGX22, and EP4CGX30 devices. The EP4CGX50, EP4CGX75, EP4CGX110, and EP4CGX150 devices have a total of four pairs of CLKIN/REFCLK pins located in I/O banks 3A, 3B, 8A, and 8B. I/O banks 3B and 8B can also support single-ended clock inputs. For more information about the CLKIN/REFCLK pin location, refer to [Figure 6-10 on page 6-18](#) and [Figure 6-11 on page 6-19](#).

The CLKIN/REFCLK pins are powered by dedicated  $V_{CC\_CLKIN3A}$ ,  $V_{CC\_CLKIN3B}$ ,  $V_{CC\_CLKIN8A}$ , and  $V_{CC\_CLKIN8B}$  power supplies separately in their respective I/O banks to avoid the different power level requirements in the same bank for GPIO.

**Table 6-10. Cyclone IV GX HSSI REFCLK I/O Standard Support Using GPIO CLKIN Pins <sup>(1)</sup>, <sup>(2)</sup>**

I/O Standard	HSSI Protocol	Coupling	Termination	VCC_CLKIN Level		I/O Pin Type		
				Input	Output	Column I/O	Row I/O	Supported I/O Banks
LVDS	All	Differential AC (Need off chip resistor to restore $V_{CM}$ )	Off chip	2.5V	Not supported	Yes	No	3A, 3B, 8A, 8B
LVPECL	All		Off chip	2.5V	Not supported	Yes	No	3A, 3B, 8A, 8B
1.2V, 1.5V, 3.3V PCML	All		Off chip	2.5V	Not supported	Yes	No	3A, 3B, 8A, 8B
	All		Off chip	2.5V	Not supported	Yes	No	3A, 3B, 8A, 8B
	All	Off chip	2.5V	Not supported	Yes	No	3A, 3B, 8A, 8B	
HCSL	PCIe	Differential DC	Off chip	2.5V	Not supported	Yes	No	3A, 3B, 8A, 8B

**Notes to Table 6-10:**

- (1) The EP4CGX15, EP4CGX22, and EP4CGX30 devices have two pairs of dedicated clock input pins in banks 3A and 8A for HSSI input reference clock. I/O banks 3B and 8B are not available in EP4CGX15, EP4CGX22, and EP4CGX30 devices.
- (2) The EP4CGX50, EP4CGX75, EP4CGX110, and EP4CGX150 devices have four pairs of dedicated clock input pins in banks 3A, 3B, 8A, and 8B for HSSI input or single-ended clock input.

 For more information about the AC-coupled termination scheme for the HSSI reference clock, refer to the *Cyclone IV Transceivers Architecture* chapter.

## LVDS I/O Standard Support in Cyclone IV Devices

The LVDS I/O standard is a high-speed, low-voltage swing, low power, and GPIO interface standard. Cyclone IV devices meet the ANSI/TIA/EIA-644 standard with the following exceptions:

- The maximum differential output voltage ( $V_{OD}$ ) is increased to 600 mV. The maximum  $V_{OD}$  for ANSI specification is 450 mV.
- The input voltage range is reduced to the range of 1.0 V to 1.6 V, 0.5 V to 1.85 V, or 0 V to 1.8 V based on different frequency ranges. The ANSI/TIA/EIA-644 specification supports an input voltage range of 0 V to 2.4 V.

 For LVDS I/O standard electrical specifications in Cyclone IV devices, refer to the *Cyclone IV Device Datasheet* chapter.

## Designing with LVDS

Cyclone IV I/O banks support the LVDS I/O standard. The Cyclone IV GX right I/O banks support true LVDS transmitters while the Cyclone IV E left and right I/O banks support LVDS transmitters. On the top and bottom I/O banks, the emulated LVDS transmitters are supported using two single-ended output buffers with external resistors. One of the single-ended output buffers is programmed to have opposite polarity. The LVDS receiver requires an external 100- $\Omega$  termination resistor between the two signals at the input buffer.

Figure 6-12 shows a point-to-point LVDS interface using Cyclone IV devices true LVDS output and input buffers.

**Figure 6-12. Cyclone IV Devices LVDS Interface with True Output Buffer on the Right I/O Banks**

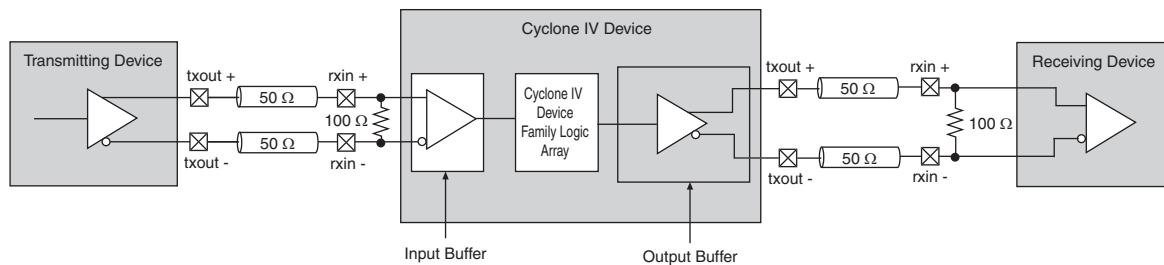
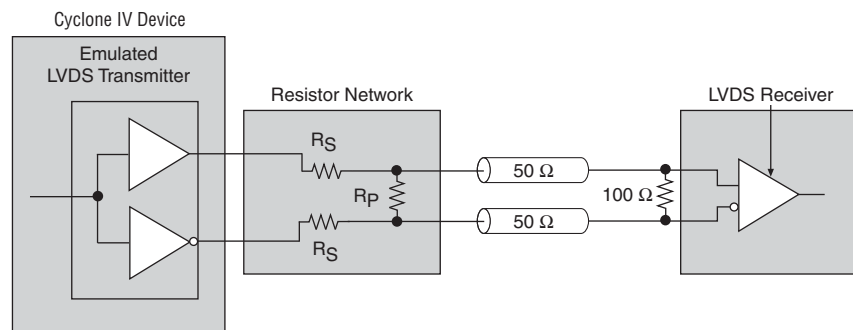

Figure 6-13 shows a point-to-point LVDS interface with Cyclone IV devices LVDS using two single-ended output buffers and external resistors.

**Figure 6-13. LVDS Interface with External Resistor Network on the Top and Bottom I/O Banks** (1)



**Note to Figure 6-13:**

(1)  $R_S = 120 \Omega$ .  $R_P = 170 \Omega$ .

## BLVDS I/O Standard Support in Cyclone IV Devices

The BLVDS I/O standard is a high-speed differential data transmission technology that extends the benefits of standard point-to-point LVDS to multipoint configuration that supports bidirectional half-duplex communication. BLVDS differs from standard LVDS by providing a higher drive to achieve similar signal swings at the receiver while loaded with two terminations at both ends of the bus.

Figure 6-14 shows a typical BLVDS topology with multiple transmitter and receiver pairs.

**Figure 6-14. BLVDS Topology with Cyclone IV Devices Transmitters and Receivers**

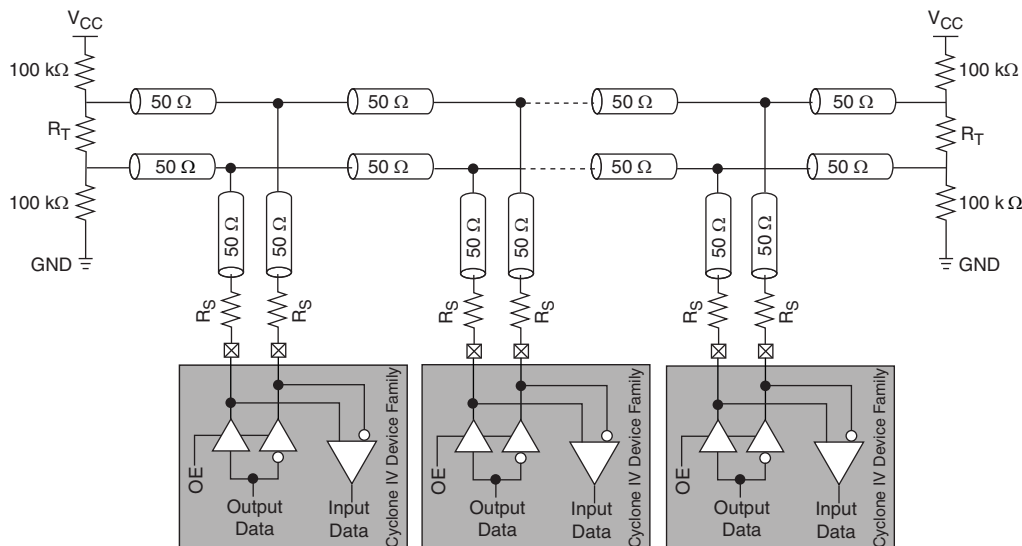

The BLVDS I/O standard is supported on the top, bottom, and right I/O banks of Cyclone IV devices. The BLVDS transmitter uses two single-ended output buffers with the second output buffer programmed as inverted, while the BLVDS receiver uses a true LVDS input buffer. The transmitter and receiver share the same pins. An output-enabled (OE) signal is required to tristate the output buffers when the LVDS input buffer receives a signal.

For more information, refer to the [Cyclone IV Device Datasheet](#) chapter.

### Designing with BLVDS



The BLVDS bidirectional communication requires termination at both ends of the bus in BLVDS. The termination resistor ( $R_T$ ) must match the bus differential impedance, which in turn depends on the loading on the bus. Increasing the load decreases the bus differential impedance. With termination at both ends of the bus, termination is not required between the two signals at the input buffer. A single series resistor ( $R_S$ ) is required at the output buffer to match the output buffer impedance to the transmission line impedance. However, this series resistor affects the voltage swing at the input buffer. The maximum data rate achievable depends on many factors.

Altera recommends that you perform simulation using the IBIS model while considering factors such as bus loading, termination values, and output and input buffer location on the bus to ensure that the required performance is achieved.

For more information about BLVDS interface support in Altera devices, refer to [AN 522: Implementing Bus LVDS Interface in Supported Altera Device Families](#).

## RSDS, Mini-LVDS, and PPDS I/O Standard Support in Cyclone IV Devices

The RSDS, mini-LVDS, and PPDS I/O standards are used in chip-to-chip applications between the timing controller and the column drivers on the display panels such as LCD monitor panels and LCD televisions. Cyclone IV devices meet the National Semiconductor Corporation RSDS Interface Specification, Texas Instruments mini-LVDS Interface Specification, and National Semiconductor Corporation PPDS Interface Specification to support RSDS, mini-LVDS and PPDS output standards, respectively.

- 
 For Cyclone IV devices RSDS, mini-LVDS, and PPDS output electrical specifications, refer to the *Cyclone IV Device Datasheet* chapter.
- 
 For more information about the RSDS I/O standard, refer to the RSDS specification from the National Semiconductor website ([www.national.com](http://www.national.com)).

### Designing with RSDS, Mini-LVDS, and PPDS

Cyclone IV I/O banks support RSDS, mini-LVDS, and PPDS output standards. The right I/O banks support true RSDS, mini-LVDS, and PPDS transmitters. On the top and bottom I/O banks, RSDS, mini-LVDS, and PPDS transmitters are supported using two single-ended output buffers with external resistors. The two single-ended output buffers are programmed to have opposite polarity.

Figure 6-15 shows an RSDS, mini-LVDS, or PPDS interface with a true output buffer.

**Figure 6-15. Cyclone IV Devices RSDS, Mini-LVDS, or PPDS Interface with True Output Buffer on the Right I/O Banks**

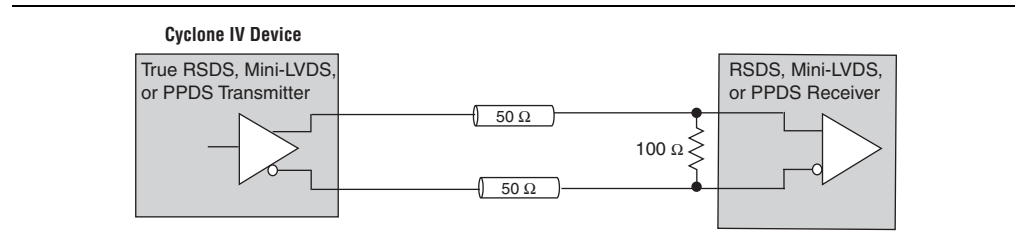
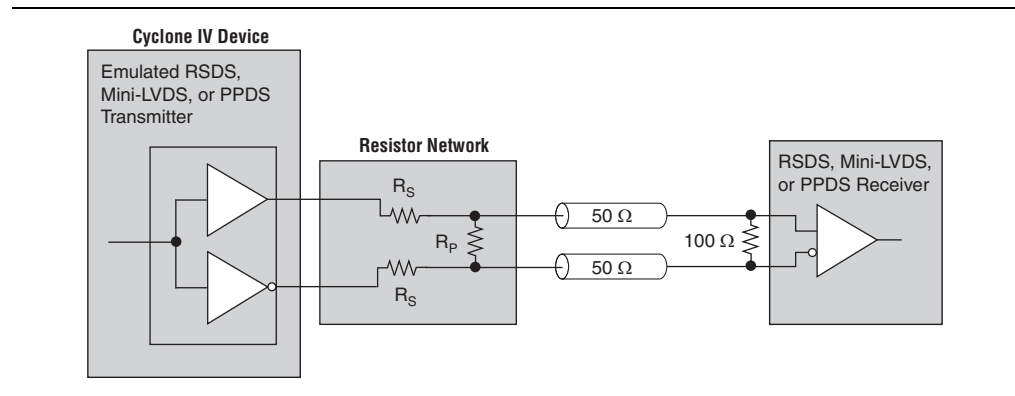

Figure 6-16 shows an RSDS, mini-LVDS, or PPDS interface with two single-ended output buffers and external resistors.

**Figure 6-16. RSDS, Mini-LVDS, or PPDS Interface with External Resistor Network on the Top and Bottom I/O Banks <sup>(1)</sup>**



**Figure 6-16. RSDS, Mini-LVDS, or PPDS Interface with External Resistor Network on the Top and Bottom I/O Banks <sup>(1)</sup>**

**Note to Figure 6-16:**

(1)  $R_S$  and  $R_P$  values are pending characterization.

A resistor network is required to attenuate the output voltage swing to meet RSDS, mini-LVDS, and PPDS specifications when using emulated transmitters. You can modify the resistor network values to reduce power or improve the noise margin.

The resistor values chosen must satisfy Equation 6-1.

**Equation 6-1. Resistor Network**

$$\frac{R_S \times \frac{R_P}{2}}{R_S + \frac{R_P}{2}} = 50 \Omega$$



Altera recommends that you perform simulations using Cyclone IV devices IBIS models to validate that custom resistor values meet the RSDS, mini-LVDS, or PPDS requirements.

It is possible to use a single external resistor instead of using three resistors in the resistor network for an RSDS interface, as shown in Figure 6-17. The external single-resistor solution reduces the external resistor count while still achieving the required signaling level for RSDS. However, the performance of the single-resistor solution is lower than the performance with the three-resistor network.

Figure 6-17 shows the RSDS interface with a single resistor network on the top and bottom I/O banks.

**Figure 6-17. RSDS Interface with Single Resistor Network on the Top and Bottom I/O Banks <sup>(1)</sup>**

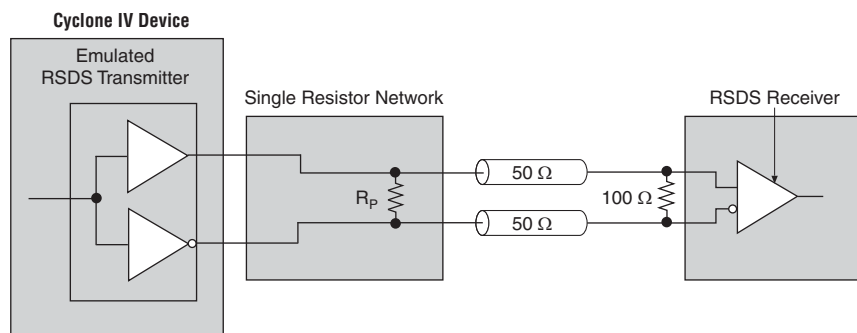

**Note to Figure 6-17:**

(1)  $R_P$  value is pending characterization.

## LVPECL I/O Support in Cyclone IV Devices

The LVPECL I/O standard is a differential interface standard that requires a 2.5-V  $V_{CCIO}$ . This standard is used in applications involving video graphics, telecommunications, data communications, and clock distribution. Cyclone IV devices support the LVPECL input standard at the dedicated clock input pins only. The LVPECL receiver requires an external 100- $\Omega$  termination resistor between the two signals at the input buffer.

For the LVPECL I/O standard electrical specification, refer to the *Cyclone IV Device Datasheet* chapter.

AC coupling is required when the LVPECL common mode voltage of the output buffer is higher than the Cyclone IV devices LVPECL input common mode voltage.

Figure 6-18 shows the AC-coupled termination scheme. The 50- $\Omega$  resistors used at the receiver are external to the device. DC-coupled LVPECL is supported if the LVPECL output common mode voltage is in the Cyclone IV devices LVPECL input buffer specification (refer to Figure 6-19).

**Figure 6-18. LVPECL AC-Coupled Termination <sup>(1)</sup>**

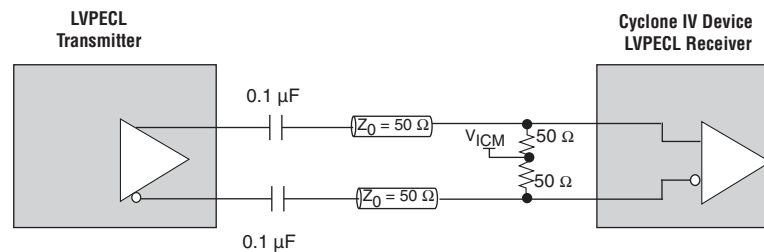

**Note to Figure 6-18:**

(1) The LVPECL AC-coupled termination is applicable only when an Altera FPGA transmitter is used.

Figure 6-19 shows the LVPECL DC-coupled termination.

**Figure 6-19. LVPECL DC-Coupled Termination <sup>(1)</sup>**



**Note to Figure 6-19:**

(1) The LVPECL DC-coupled termination is applicable only when an Altera FPGA transmitter is used.

## Differential SSTL I/O Standard Support in Cyclone IV Devices

The differential SSTL I/O standard is a memory-bus standard used for applications such as high-speed DDR SDRAM interfaces. Cyclone IV devices support differential SSTL-2 and SSTL-18 I/O standards. The differential SSTL output standard is only supported at PLL#\_CLKOUT pins using two single-ended SSTL output buffers (PLL#\_CLKOUT<sub>p</sub> and PLL#\_CLKOUT<sub>n</sub>), with the second output programmed to have opposite polarity. The differential SSTL input standard is supported on the GCLK pins only, treating differential inputs as two single-ended SSTL and only decoding one of them.

The differential SSTL I/O standard requires two differential inputs with an external reference voltage ( $V_{REF}$ ) as well as an external termination voltage ( $V_{TT}$ ) of  $0.5 \times V_{CCIO}$  to which termination resistors are connected.

 For differential SSTL electrical specifications, refer to “[Differential I/O Standard Termination](#)” on page 6-15 and the *Cyclone IV Device Datasheet* chapter.

 [Figure 6-8](#) on page 6-15 shows the differential SSTL Class I and Class II interface.

## Differential HSTL I/O Standard Support in Cyclone IV Devices

The differential HSTL I/O standard is used for the applications designed to operate in 0 V to 1.2 V, 0 V to 1.5 V, or 0 V to 1.8 V HSTL logic switching range. Cyclone IV devices support differential HSTL-18, HSTL-15, and HSTL-12 I/O standards. The differential HSTL input standard is available on GCLK pins only, treating the differential inputs as two single-ended HSTL and only decoding one of them. The differential HSTL output standard is only supported at the PLL#\_CLKOUT pins using two single-ended HSTL output buffers (PLL#\_CLKOUT<sub>p</sub> and PLL#\_CLKOUT<sub>n</sub>), with the second output programmed to have opposite polarity.

The differential HSTL I/O standard requires two differential inputs with an external reference voltage ( $V_{REF}$ ), as well as an external termination voltage ( $V_{TT}$ ) of  $0.5 \times V_{CCIO}$  to which termination resistors are connected.

 For differential HSTL signaling characteristics, refer to “[Differential I/O Standard Termination](#)” on page 6-15 and the *Cyclone IV Device Datasheet* chapter.

 [Figure 6-7](#) on page 6-15 shows the differential HSTL Class I and Class II interface.

## True Differential Output Buffer Feature

Cyclone IV devices true differential transmitters offer programmable pre-emphasis—you can turn it on or off. The default setting is on.

### Programmable Pre-Emphasis

The programmable pre-emphasis boosts the high frequencies of the output signal to compensate the frequency-dependant attenuation of the transmission line to maximize the data eye opening at the far-end receiver. Without pre-emphasis, the output current is limited by the  $V_{OD}$  specification and the output impedance of the transmitter. At high frequency, the slew rate may not be fast enough to reach full  $V_{OD}$ .

before the next edge; this may lead to pattern-dependent jitter. With pre-emphasis, the output current is momentarily boosted during switching to increase the output slew rate. The overshoot produced by this extra switching current is different from the overshoot caused by signal reflection. This overshoot happens only during switching, and does not produce ringing.

The Quartus II software allows two settings for programmable pre-emphasis control—**0** and **1**, in which **0** is pre-emphasis off and **1** is pre-emphasis on. The default setting is **1**. The amount of pre-emphasis needed depends on the amplification of the high-frequency components along the transmission line. You must adjust the setting to suit your designs, as pre-emphasis decreases the amplitude of the low-frequency component of the output signal.

Figure 6–20 shows the differential output signal with pre-emphasis.

**Figure 6–20. The Output Signal with Pre-Emphasis**

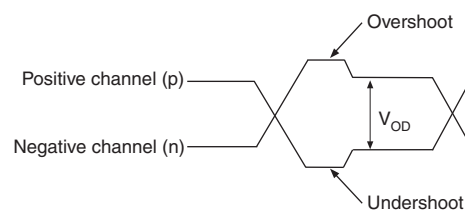

## High-Speed I/O Timing

This section discusses the timing budget, waveforms, and specifications for source-synchronous signaling in Cyclone IV devices. Timing for source-synchronous signaling is based on skew between the data and clock signals.

High-speed differential data transmission requires timing parameters provided by IC vendors and requires you to consider the board skew, cable skew, and clock jitter. This section provides information about high-speed I/O standards timing parameters in Cyclone IV devices.

Table 6–11 defines the parameters of the timing diagram shown in Figure 6–21.

**Table 6–11. High-Speed I/O Timing Definitions (Part 1 of 2)**

Parameter	Symbol	Description
Transmitter channel-to-channel skew <sup>(1)</sup>	TCCS	The timing difference between the fastest and slowest output edges, including $t_{CO}$ variation and clock skew. The clock is included in the TCCS measurement.
Sampling window	SW	The period of time during which the data must be valid in order for you to capture it correctly. The setup and hold times determine the ideal strobe position in the sampling window. $T_{SW} = T_{SU} + T_{hd} + \text{PLL jitter}$ .
Time unit interval	TUI	The TUI is the data-bit timing budget allowed for skew, propagation delays, and data sampling window.
Receiver input skew margin	RSKM	RSKM is defined by the total margin left after accounting for the sampling window and TCCS. The RSKM equation is: $\text{RSKM} = \frac{\text{TUI} - \text{SW} - \text{TCCS}}{2}$

**Table 6-11. High-Speed I/O Timing Definitions (Part 2 of 2)**

Parameter	Symbol	Description
Input jitter tolerance (peak-to-peak)	—	Allowed input jitter on the input clock to the PLL that is tolerable while maintaining PLL lock.
Output jitter (peak-to-peak)	—	Peak-to-peak output jitter from the PLL.

**Note to Table 6-11:**

- The TCCS specification applies to the entire bank of differential I/O as long as the SERDES logic is placed in the logic array block (LAB) adjacent to the output pins.

**Figure 6-21. High-Speed I/O Timing Diagram**

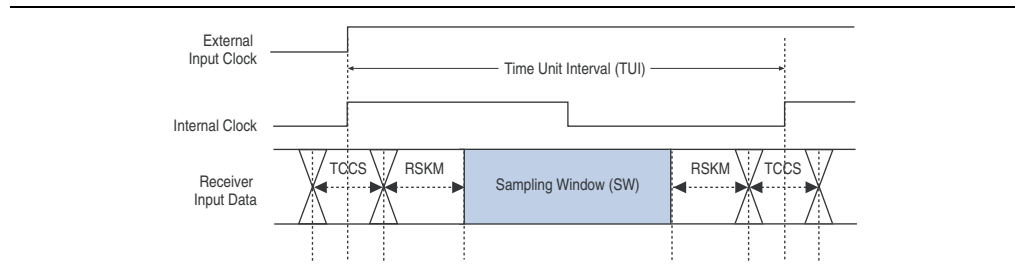
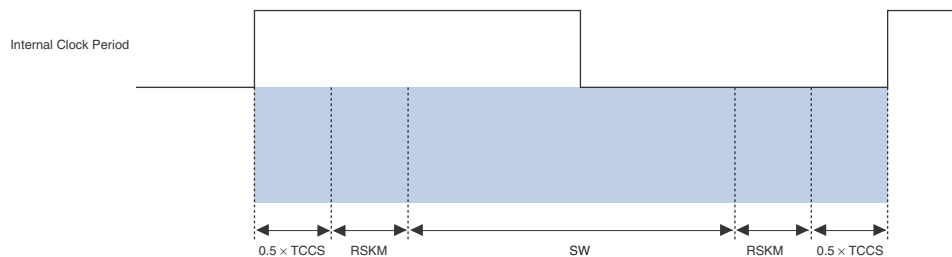

Figure 6-22 shows the Cyclone IV devices high-speed I/O timing budget.

**Figure 6-22. Cyclone IV Devices High-Speed I/O Timing Budget (1)**



**Note to Figure 6-22:**

- The equation for the high-speed I/O timing budget is:  

$$\text{Period} = 0.5 \times \text{TCCS} + \text{RSKM} + \text{SW} + \text{RSKM} + 0.5 \times \text{TCCS}$$

 For more information, refer to the *Cyclone IV Device Datasheet* chapter.

## Design Guidelines

This section provides guidelines for designing with Cyclone IV devices.

### Differential Pad Placement Guidelines

To maintain an acceptable noise level on the  $V_{CCIO}$  supply, you must observe some restrictions on the placement of single-ended I/O pins in relation to differential pads.

 For guidelines on placing single-ended pads with respect to differential pads in Cyclone IV devices, refer to “*Pad Placement and DC Guidelines*” on page 6-23.

## Board Design Considerations

This section explains how to achieve the optimal performance from a Cyclone IV I/O interface and ensure first-time success in implementing a functional design with optimal signal quality. You must consider the critical issues of controlled impedance of traces and connectors, differential routing, and termination techniques to get the best performance from Cyclone IV devices.

Use the following general guidelines to improve signal quality:

- Base board designs on controlled differential impedance. Calculate and compare all parameters, such as trace width, trace thickness, and the distance between two differential traces.
- Maintain equal distance between traces in differential I/O standard pairs as much as possible. Routing the pair of traces close to each other maximizes the common-mode rejection ratio (CMRR).
- Longer traces have more inductance and capacitance. These traces must be as short as possible to limit signal integrity issues.
- Place termination resistors as close to receiver input pins as possible.
- Use surface mount components.
- Avoid 90° corners on board traces.
- Use high-performance connectors.
- Design backplane and card traces so that trace impedance matches the impedance of the connector and termination.
- Keep an equal number of vias for both signal traces.
- Create equal trace lengths to avoid skew between signals. Unequal trace lengths result in misplaced crossing points and decrease system margins as the TCCS value increases.
- Limit vias because they cause discontinuities.
- Keep switching transistor-to-transistor logic (TTL) signals away from differential signals to avoid possible noise coupling.
- Do not route TTL clock signals to areas under or above the differential signals.
- Analyze system-level signals.



For PCB layout guidelines, refer to [AN 224: High-Speed Board Layout Guidelines](#) and [AN 315: Guidelines for Designing High-Speed FPGA PCBs](#).

## Software Overview

Cyclone IV devices high-speed I/O system interfaces are created in core logic by a Quartus II software megafunction because they do not have a dedicated circuit for the SERDES. Cyclone IV devices use the I/O registers and LE registers to improve the timing performance and support the SERDES. The Quartus II software allows you to design your high-speed interfaces using ALTLVDS megafunction. This megafunction

implements either a high-speed deserializer receiver or a high-speed serializer transmitter. There is a list of parameters in the ALTLVDS megafunction that you can set to customize your SERDES based on your design requirements. The megafunction is optimized to use Cyclone IV devices resources to create high-speed I/O interfaces in the most effective manner.



When you use Cyclone IV devices with the ALTLVDS megafunction, the interface always sends the MSB of your parallel data first.



For more details about designing your high-speed I/O systems interfaces using the ALTLVDS megafunction, refer to the *ALTLVDS Megafunction User Guide* and the *Quartus II Handbook*.

## Document Revision History

Table 6-12 lists the revision history for this chapter.

**Table 6-12. Document Revision History (Part 1 of 2)**

Date	Version	Changes
March 2016	2.7	<ul style="list-style-type: none"> <li>■ Updated Table 6-5 and Table 6-9 to remove support for the N148 package.</li> </ul>
May 2013	2.6	<ul style="list-style-type: none"> <li>■ Updated Table 6-2 by adding Note (9).</li> <li>■ Updated Table 6-4 and Table 6-8 to add new device options and packages.</li> </ul>
February 2013	2.5	<ul style="list-style-type: none"> <li>■ Updated Table 6-4 and Table 6-8 to add new device options and packages.</li> </ul>
October 2012	2.4	<ul style="list-style-type: none"> <li>■ Updated “I/O Banks” and “High Speed Serial Interface (HSSI) Input Reference Clock Support” sections.</li> <li>■ Updated Table 6-3 and Table 6-5.</li> <li>■ Updated Figure 6-10.</li> </ul>
November 2011	2.3	<ul style="list-style-type: none"> <li>■ Updated “Differential SSTL I/O Standard Support in Cyclone IV Devices” and “Differential HSTL I/O Standard Support in Cyclone IV Devices” sections.</li> <li>■ Updated Table 6-1, Table 6-8, and Table 6-9.</li> <li>■ Updated Figure 6-1.</li> </ul>
December 2010	2.2	<ul style="list-style-type: none"> <li>■ Updated for the Quartus II software version 10.1 release.</li> <li>■ Added Cyclone IV E new device package information.</li> <li>■ Added “Clock Pins Functionality” section.</li> <li>■ Updated Table 6-4 and Table 6-8.</li> <li>■ Minor text edits.</li> </ul>
July 2010	2.1	<ul style="list-style-type: none"> <li>■ Updated “Cyclone IV I/O Elements”, “Programmable Pull-Up Resistor”, “I/O Banks”, “High-Speed I/O Interface”, and “Designing with BLVDS” sections.</li> <li>■ Updated Table 6-6 and Table 6-7.</li> <li>■ Updated Figure 6-19.</li> </ul>

**Table 6-12. Document Revision History (Part 2 of 2)**

Date	Version	Changes
February 2010	2.0	<ul style="list-style-type: none"><li>■ Added Cyclone IV E devices information for the Quartus II software version 9.1 SP1 release.</li><li>■ Updated Table 6-2, Table 6-3, and Table 6-10.</li><li>■ Updated “I/O Banks” section.</li><li>■ Added Figure 6-9.</li><li>■ Updated Figure 6-10 and Figure 6-11.</li><li>■ Added Table 6-4, Table 6-6, and Table 6-8.</li></ul>
November 2009	1.0	Initial release.

This chapter describes the memory interface pin support and the external memory interface features of Cyclone® IV devices.

In addition to an abundant supply of on-chip memory, Cyclone IV devices can easily interface with a broad range of external memory devices, including DDR2 SDRAM, DDR SDRAM, and QDR II SRAM. External memory devices are an important system component of a wide range of image processing, storage, communications, and general embedded applications.

 Altera recommends that you construct all DDR2 or DDR SDRAM external memory interfaces using the Altera® ALTMEMPHY megafunction. You can implement the controller function using the Altera DDR2 or DDR SDRAM memory controllers, third-party controllers, or a custom controller for unique application needs. Cyclone IV devices support QDR II interfaces electrically, but Altera does not supply controller or physical layer (PHY) megafunctions for QDR II interfaces.

This chapter includes the following sections:

- “Cyclone IV Devices Memory Interfaces Pin Support” on page 7-2
- “Cyclone IV Devices Memory Interfaces Features” on page 7-12

 For more information about supported maximum clock rate, device and pin planning, IP implementation, and device termination, refer to the *External Memory Interface Handbook*.

Figure 7-1 shows the block diagram of a typical external memory interface data path in Cyclone IV devices.

**Figure 7-1. Cyclone IV Devices External Memory Data Path** (1)

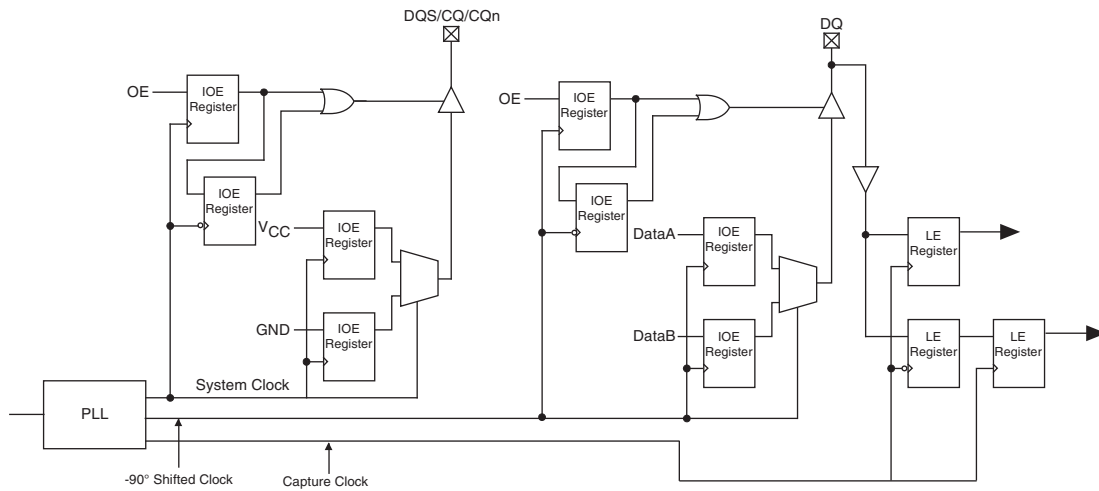

**Note to Figure 7-1:**

(1) All clocks shown here are global clocks.

For more information about implementing complete external memory interfaces, refer to the *External Memory Interface Handbook*.

## Cyclone IV Devices Memory Interfaces Pin Support

Cyclone IV devices use data (DQ), data strobe (DQS), clock, command, and address pins to interface with external memory. Some memory interfaces use the data mask (DM) or byte write select (BWS#) pins to enable data masking. This section describes how Cyclone IV devices support all these different pins.

For more information about pin utilization, refer to *Volume 2: Device, Pin, and Board Layout Guidelines* of the *External Memory Interface Handbook*.

### Data and Data Clock/Strobe Pins

Cyclone IV data pins for external memory interfaces are called D for write data, Q for read data, or DQ for shared read and write data pins. The read-data strobes or read clocks are called DQS pins. Cyclone IV devices support both bidirectional data strobes and unidirectional read clocks. Depending on the external memory standard, the DQ and DQS are bidirectional signals (in DDR2 and DDR SDRAM) or unidirectional signals (in QDR II SRAM). Connect the bidirectional DQ data signals to the same Cyclone IV devices DQ pins. For unidirectional D or Q signals, connect the read-data signals to a group of DQ pins and the write-data signals to a different group of DQ pins.

In QDR II SRAM, the Q read-data group must be placed at a different  $V_{REF}$  bank location from the D write-data group, command, or address pins.

In Cyclone IV devices, DQS is used only during write mode in DDR2 and DDR SDRAM interfaces. Cyclone IV devices ignore DQS as the read-data strobe because the PHY internally generates the read capture clock for read mode. However, you must connect the DQS pin to the DQS signal in DDR2 and DDR SDRAM interfaces, or to the CQ signal in QDR II SRAM interfaces.



Cyclone IV devices do not support differential strobe pins, which is an optional feature in the DDR2 SDRAM device.



When you use the Altera Memory Controller MegaCore<sup>®</sup> function, the PHY is instantiated for you. For more information about the memory interface data path, refer to the *External Memory Interface Handbook*.



ALTMEMPHY is a self-calibrating megafunction, enhanced to simplify the implementation of the read-data path in different memory interfaces. The auto-calibration feature of ALTMEMPHY provides ease-of-use by optimizing clock phases and frequencies across process, voltage, and temperature (PVT) variations. You can save on the global clock resources in Cyclone IV devices through the ALTMEMPHY megafunction because you are not required to route the DQS signals on the global clock buses (because DQS is ignored for read capture). Resynchronization issues do not arise because no transfer occurs from the memory domain clock (DQS) to the system domain for capturing data DQ.

All I/O banks in Cyclone IV devices can support DQ and DQS signals with DQ-bus modes of  $\times 8$ ,  $\times 9$ ,  $\times 16$ ,  $\times 18$ ,  $\times 32$ , and  $\times 36$  except Cyclone IV GX devices that do not support left I/O bank interface. DDR2 and DDR SDRAM interfaces use  $\times 8$  mode DQS group regardless of the interface width. For a wider interface, you can use multiple  $\times 8$  DQ groups to achieve the desired width requirement.

In the  $\times 9$ ,  $\times 18$ , and  $\times 36$  modes, a pair of complementary DQS pins (CQ and CQ#) drives up to 9, 18, or 36 DQ pins, respectively, in the group, to support one, two, or four parity bits and the corresponding data bits. The  $\times 9$ ,  $\times 18$ , and  $\times 36$  modes support the QDR II memory interface. CQ# is the inverted read-clock signal that is connected to the complementary data strobe (DQS or CQ#) pin. You can use any unused DQ pins as regular user I/O pins if they are not used as memory interface signals.



For more information about unsupported DQS and DQ groups of the Cyclone IV transceivers that run at  $\geq 2.97$  Gbps data rate, refer to the *Cyclone IV Device Family Pin Connection Guidelines*.

Table 7-1 lists the number of DQS or DQ groups supported on each side of the Cyclone IV GX device.

**Table 7-1. Cyclone IV GX Device DQS and DQ Bus Mode Support for Each Side of the Device**

Device	Package	Side	Number ×8 Groups	Number ×9 Groups	Number ×16 Groups	Number ×18 Groups	Number ×32 Groups	Number ×36 Groups
EP4CGX15	169-pin FBGA	Right	1	0	0	0	—	—
		Top <sup>(1)</sup>	1	0	0	0	—	—
		Bottom <sup>(2)</sup>	1	0	0	0	—	—
EP4CGX22 EP4CGX30	169-pin FBGA	Right	1	0	0	0	—	—
		Top <sup>(1)</sup>	1	0	0	0	—	—
		Bottom <sup>(2)</sup>	1	0	0	0	—	—
	324-pin FBGA	Right	2	2	1	1	—	—
		Top	2	2	1	1	—	—
		Bottom	2	2	1	1	—	—
	484-pin FBGA <sup>(3)</sup>	Right	4	2	2	2	1	1
		Top	4	2	2	2	1	1
		Bottom	4	2	2	2	1	1
EP4CGX50 EP4CGX75	484-pin FBGA	Right	4	2	2	2	1	1
		Top	4	2	2	2	1	1
		Bottom	4	2	2	2	1	1
	672-pin FBGA	Right	4	2	2	2	1	1
		Top	4	2	2	2	1	1
		Bottom	4	2	2	2	1	1
EP4CGX110 EP4CGX150	484-pin FBGA	Right	4	2	2	2	1	1
		Top	4	2	2	2	1	1
		Bottom	4	2	2	2	1	1
	672-pin FBGA	Right	4	2	2	2	1	1
		Top	4	2	2	2	1	1
		Bottom	4	2	2	2	1	1
	896-pin FBGA	Right	6	3	2	2	1	1
		Top	6	3	3	3	1	1
		Bottom	6	3	3	3	1	1

**Notes to Table 7-1:**

- (1) Some of the DQ pins can be used as RUP and RDN pins. You cannot use these groups if you are using these pins as RUP and RDN pins for OCT calibration.
- (2) Some of the DQ pins can be used as RUP pins while the DM pins can be used as RDN pins. You cannot use these groups if you are using the RUP and RDN pins for OCT calibration.
- (3) Only available for EP4CGX30 device.

Table 7-2 lists the number of DQS or DQ groups supported on each side of the Cyclone IV E device.

**Table 7-2. Cyclone IV E Device DQS and DQ Bus Mode Support for Each Side of the Device (Part 1 of 3)**

Device	Package	Side	Number ×8 Groups	Number ×9 Groups	Number ×16 Groups	Number ×18 Groups	Number ×32 Groups	Number ×36 Groups
EP4CE6 EP4CE10	144-pin EQFP	Left	0	0	0	0	—	—
		Right	0	0	0	0	—	—
		Bottom <sup>(1), (3)</sup>	1	0	0	0	—	—
		Top <sup>(1), (4)</sup>	1	0	0	0	—	—
	256-pin UBGA	Left <sup>(1)</sup>	1	1	0	0	—	—
		Right <sup>(2)</sup>	1	1	0	0	—	—
		Bottom	2	2	1	1	—	—
		Top	2	2	1	1	—	—
	256-pin FBGA	Left <sup>(1)</sup>	1	1	0	0	—	—
		Right <sup>(2)</sup>	1	1	0	0	—	—
		Bottom	2	2	1	1	—	—
		Top	2	2	1	1	—	—
EP4CE15	144-pin EQFP	Left	0	0	0	0	—	—
		Right	0	0	0	0	—	—
		Bottom <sup>(1), (3)</sup>	1	0	0	0	—	—
		Top <sup>(1), (4)</sup>	1	0	0	0	—	—
	164-pin MBGA	Left	0	0	0	0	—	—
		Right	0	0	0	0	—	—
		Bottom <sup>(1), (3)</sup>	1	0	0	0	—	—
		Top <sup>(1), (4)</sup>	1	0	0	0	—	—
	256-pin MBGA	Left	1	1	0	0	—	—
		Right	1	1	0	0	—	—
		Bottom <sup>(1), (3)</sup>	2	2	1	1	—	—
		Top <sup>(1), (4)</sup>	2	2	1	1	—	—
	256-pin UBGA	Left <sup>(1)</sup>	1	1	0	0	—	—
		Right <sup>(2)</sup>	1	1	0	0	—	—
		Bottom	2	2	1	1	—	—
		Top	2	2	1	1	—	—
	256-pin FBGA	Left <sup>(1)</sup>	1	1	0	0	—	—
		Right <sup>(2)</sup>	1	1	0	0	—	—
		Bottom	2	2	1	1	—	—
		Top	2	2	1	1	—	—
	484-pin FBGA	Left	4	4	2	2	1	1
		Right	4	4	2	2	1	1
		Bottom	4	4	2	2	1	1
		Top	4	4	2	2	1	1

Table 7-2. Cyclone IV E Device DQS and DQ Bus Mode Support for Each Side of the Device (Part 2 of 3)

Device	Package	Side	Number ×8 Groups	Number ×9 Groups	Number ×16 Groups	Number ×18 Groups	Number ×32 Groups	Number ×36 Groups
EP4CE22	144-pin EQFP	Left	0	0	0	0	—	—
		Right	0	0	0	0	—	—
		Bottom <sup>(1), (3)</sup>	1	0	0	0	—	—
		Top <sup>(1), (4)</sup>	1	0	0	0	—	—
	256-pin UBGA	Left <sup>(1)</sup>	1	1	0	0	—	—
		Right <sup>(2)</sup>	1	1	0	0	—	—
		Bottom	2	2	1	1	—	—
		Top	2	2	1	1	—	—
	256-pin FBGA	Left <sup>(1)</sup>	1	1	0	0	—	—
		Right <sup>(2)</sup>	1	1	0	0	—	—
		Bottom	2	2	1	1	—	—
		Top	2	2	1	1	—	—
EP4CE30	324-pin FBGA	Left <sup>(1)</sup>	2	2	1	1	0	0
		Right <sup>(2)</sup>	2	2	1	1	0	0
		Bottom	2	2	1	1	0	0
		Top	2	2	1	1	0	0
EP4CE30 EP4CE115	484-pin FBGA	Left	4	4	2	2	1	1
		Right	4	4	2	2	1	1
		Bottom	4	4	2	2	1	1
		Top	4	4	2	2	1	1
	780-pin FBGA	Left	4	4	2	2	1	1
		Right	4	4	2	2	1	1
		Bottom	6	6	2	2	1	1
		Top	6	6	2	2	1	1
EP4CE40	324-pin FBGA	Left	2	2	1	1	0	0
		Right	2	2	1	1	0	0
		Bottom	2	2	1	1	0	0
		Top	2	2	1	1	0	0

**Table 7-2. Cyclone IV E Device DQS and DQ Bus Mode Support for Each Side of the Device (Part 3 of 3)**

Device	Package	Side	Number ×8 Groups	Number ×9 Groups	Number ×16 Groups	Number ×18 Groups	Number ×32 Groups	Number ×36 Groups
EP4CE40 EP4CE55 EP4CE75	484-pin UBGA	Left	4	4	2	2	1	1
		Right	4	4	2	2	1	1
		Bottom	4	4	2	2	1	1
		Top	4	4	2	2	1	1
	484-pin FBGA	Left	4	4	2	2	1	1
		Right	4	4	2	2	1	1
		Bottom	4	4	2	2	1	1
		Top	4	4	2	2	1	1
	780-pin FBGA	Left	4	4	2	2	1	1
		Right	4	4	2	2	1	1
		Bottom	6	6	2	2	1	1
		Top	6	6	2	2	1	1

**Notes to Table 7-2:**

- (1) Some of the DQ pins can be used as RUP and RDN pins. You cannot use these groups if you are using these pins as RUP and RDN pins for OCT calibration.
- (2) Some of the DQ pins can be used as RUP pins while the DM pins can be used as RDN pins. You cannot use these groups if you are using the RUP and RDN pins for OCT calibration.
- (3) There is no DM pin support for these groups.
- (4) PLLCLKOUT3n and PLLCLKOUT3p pins are shared with the DQ or DM pins to gain ×8 DQ group. You cannot use these groups if you are using PLLCLKOUT3n and PLLCLKOUT3p.

 For more information about device package outline, refer to the [Device Packaging Specifications](#) webpage.

DQS pins are listed in the Cyclone IV pin tables as DQSXY, in which X indicates the DQS grouping number and Y indicates whether the group is located on the top (T), bottom (B), or right (R) side of the device. Similarly, the corresponding DQ pins are marked as DQXY, in which the X denotes the DQ grouping number and Y denotes whether the group is located on the top (T), bottom (B), or right (R) side of the device. For example, DQS2T indicates a DQS pin belonging to group 2, located on the top side of the device. Similarly, the DQ pins belonging to that group is shown as DQ2T.

 Each DQ group is associated with its corresponding DQS pins, as defined in the Cyclone IV pin tables. For example:

- For DDR2 or DDR SDRAM, ×8 DQ group DQ3B [7..0] pins are associated with the DQS3B pin (same 3B group index)
- For QDR II SRAM, ×9 Q read-data group DQ3T [8..0] pins are associated with DQS0T/CQ0T and DQS1T/CQ0T# pins (same 0T group index)

The Quartus® II software issues an error message if a DQ group is not placed properly with its associated DQS.

Figure 7-2 shows the location and numbering of the DQS, DQ, or CQ# pins in the Cyclone IV GX I/O banks.

**Figure 7-2. DQS, CQ, or CQ# Pins in Cyclone IV GX I/O Banks** (1)

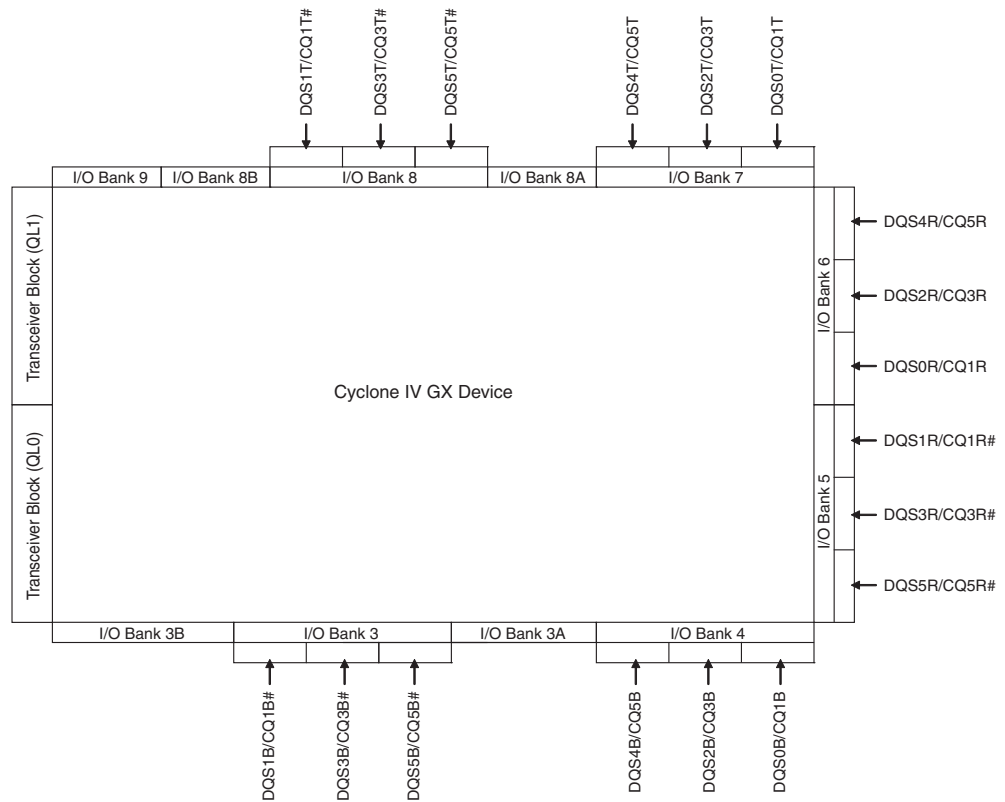

**Note to Figure 7-2:**

- (1) The DQS, CQ, or CQ# pin locations in this diagram apply to all packages in Cyclone IV GX devices except devices in 169-pin FBGA and 324-pin FBGA.

Figure 7-3 shows the location and numbering of the DQS, DQ, or CQ# pins in I/O banks of the Cyclone IV GX device in the 324-pin FBGA package only.

**Figure 7-3. DQS, CQ, or CQ# Pins for Cyclone IV GX Devices in the 324-Pin FBGA Package**

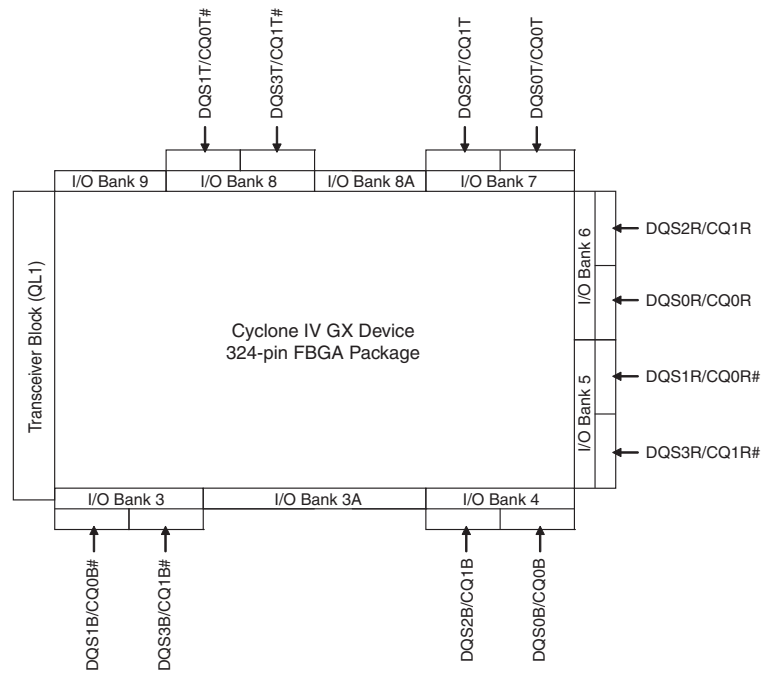

Figure 7-4 shows the location and numbering of the DQS, DQ, or CQ# pins in I/O banks of the Cyclone IV GX device in the 169-pin FBGA package.

**Figure 7-4. DQS, CQ, or CQ# Pins for Cyclone IV GX Devices in the 169-Pin FBGA Package**

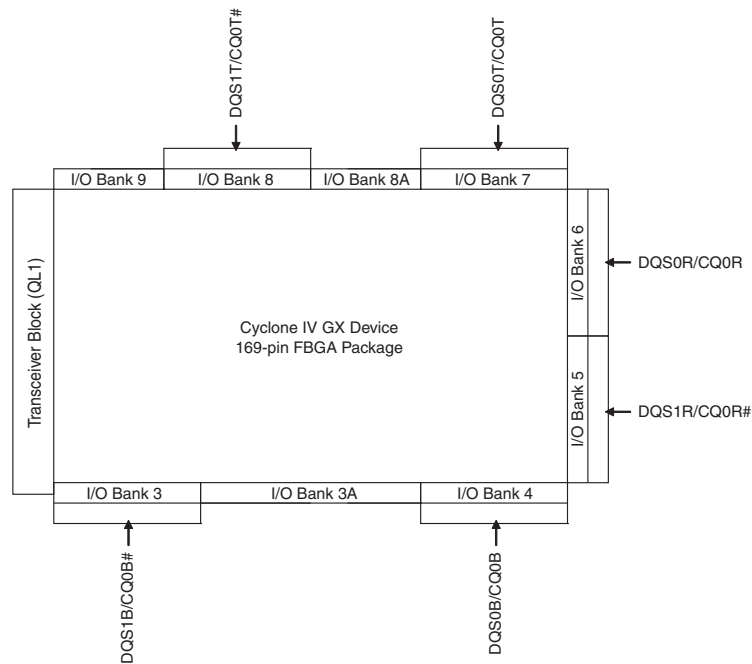
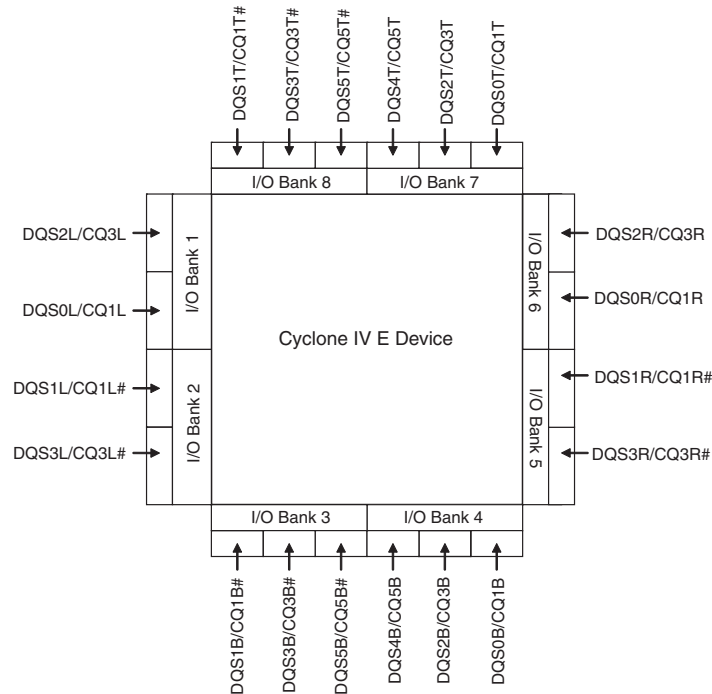

Figure 7-5 shows the location and numbering of the DQS, DQ, or CQ# pins in the Cyclone IV E device I/O banks.

**Figure 7-5. DQS, CQ, or CQ# Pins in Cyclone IV E I/O Banks** (1)



**Note to Figure 7-5:**

- (1) The DQS, CQ, or CQ# pin locations in this diagram apply to all packages in Cyclone IV E devices except devices in 144-pin EQFP.

Figure 7-6 shows the location and numbering of the DQS, DQ, or CQ# pins in I/O banks of the Cyclone IV E device in the 144-pin EQFP and 164-pin MBGA packages.

**Figure 7-6. DQS, CQ, or CQ# Pins for Cyclone IV E Devices in the 144-Pin EQFP and 164-pin MBGA Packages**

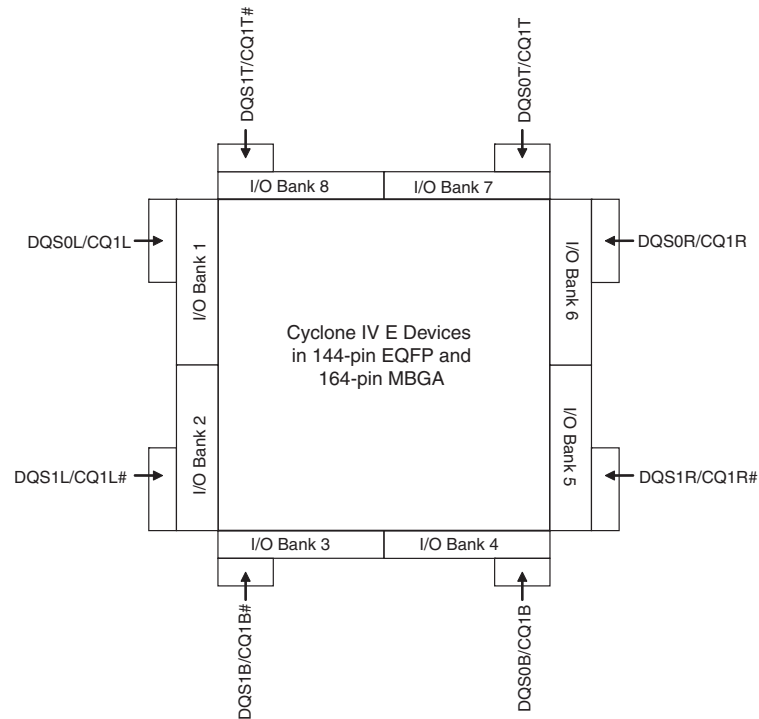

In Cyclone IV devices, the  $\times 9$  mode uses the same DQ and DQS pins as the  $\times 8$  mode, and one additional DQ pin that serves as a regular I/O pin in the  $\times 8$  mode. The  $\times 18$  mode uses the same DQ and DQS pins as  $\times 16$  mode, with two additional DQ pins that serve as regular I/O pins in the  $\times 16$  mode. Similarly, the  $\times 36$  mode uses the same DQ and DQS pins as the  $\times 32$  mode, with four additional DQ pins that serve as regular I/O pins in the  $\times 32$  mode. When not used as DQ or DQS pins, the memory interface pins are available as regular I/O pins.

## Optional Parity, DM, and Error Correction Coding Pins

Cyclone IV devices support parity in  $\times 9$ ,  $\times 18$ , and  $\times 36$  modes. One parity bit is available per eight bits of data pins. You can use any of the DQ pins for parity in Cyclone IV devices because the parity pins are treated and configured similarly to DQ pins.

DM pins are only required when writing to DDR2 and DDR SDRAM devices. QDR II SRAM devices use the BWS# signal to select the byte to be written into memory. A low signal on the DM or BWS# pin indicates the write is valid. Driving the DM or BWS# pin high causes the memory to mask the DQ signals. Each group of DQS and DQ signals has one DM pin. Similar to the DQ output signals, the DM signals are clocked by the  $-90^\circ$  shifted clock.

In Cyclone IV devices, the DM pins are preassigned in the device pinouts. The Quartus II Fitter treats the DQ and DM pins in a DQS group equally for placement purposes. The preassigned DQ and DM pins are the preferred pins to use.

Some DDR2 SDRAM and DDR SDRAM devices support error correction coding (ECC), a method of detecting and automatically correcting errors in data transmission. In 72-bit DDR2 or DDR SDRAM, there are eight ECC pins and 64 data pins. Connect the DDR2 and DDR SDRAM ECC pins to a separate DQS or DQ group in Cyclone IV devices. The memory controller needs additional logic to encode and decode the ECC data.

## Address and Control/Command Pins

The address signals and the control or command signals are typically sent at a single data rate. You can use any of the user I/O pins on all I/O banks of Cyclone IV devices to generate the address and control or command signals to the memory device.

 Cyclone IV devices do not support QDR II SRAM in the burst length of two.

## Memory Clock Pins

In DDR2 and DDR SDRAM memory interfaces, the memory clock signals (CK and CK#) are used to capture the address signals and the control or command signals. Similarly, QDR II SRAM devices use the write clocks (K and K#) to capture the address and command signals. The CK/CK# and K/K# signals are generated to resemble the write-data strobe using the DDIO registers in Cyclone IV devices.

 CK/CK# pins must be placed on differential I/O pins (DIFFIO in Pin Planner) and in the same bank or on the same side as the data pins. You can use either side of the device for wraparound interfaces. As seen in the Pin Planner Pad View, CK0 cannot be located in the same row and column pad group as any of the interfacing DQ pins.

 For more information about memory clock pin placement, refer to *Volume 2: Device, Pin, and Board Layout Guidelines* of the *External Memory Interface Handbook*.

# Cyclone IV Devices Memory Interfaces Features

This section discusses Cyclone IV memory interfaces, including DDR input registers, DDR output registers, OCT, and phase-lock loops (PLLs).

## DDR Input Registers

The DDR input registers are implemented with three internal logic element (LE) registers for every DQ pin. These LE registers are located in the logic array block (LAB) adjacent to the DDR input pin.

Figure 7-7 illustrates Cyclone IV DDR input registers.

**Figure 7-7. Cyclone IV DDR Input Registers**

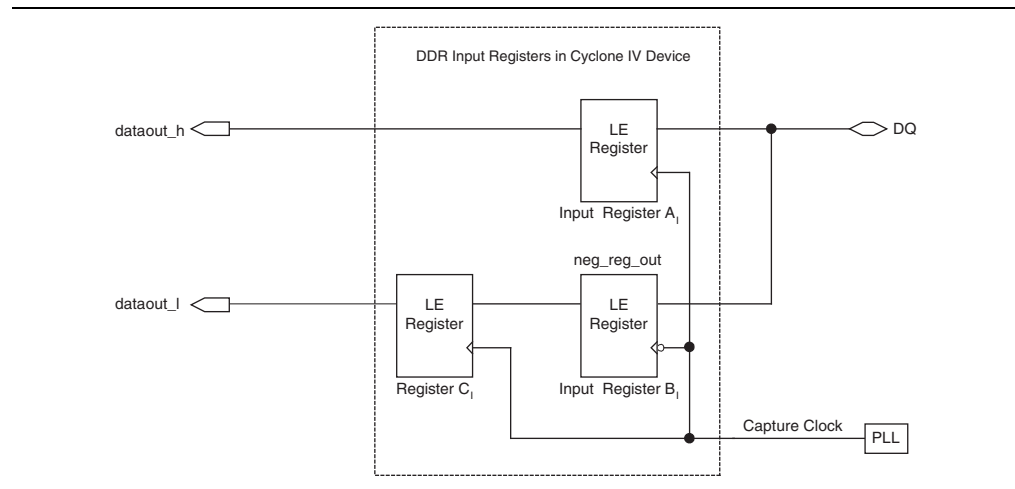

These DDR input registers are implemented in the core of devices. The DDR data is first fed to two registers, input register A<sub>1</sub> and input register B<sub>1</sub>.

- Input register A<sub>1</sub> captures the DDR data present during the rising edge of the clock
- Input register B<sub>1</sub> captures the DDR data present during the falling edge of the clock
- Register C<sub>1</sub> aligns the data before it is synchronized with the system clock

The data from the DDR input register is fed to two registers, `sync_reg_h` and `sync_reg_l`, then the data is typically transferred to a FIFO block to synchronize the two data streams to the rising edge of the system clock. Because the read-capture clock is generated by the PLL, the read-data strobe signal (DQS or CQ) is not used during read operation in Cyclone IV devices; hence, postamble is not a concern in this case.

## DDR Output Registers

A dedicated write DDIO block is implemented in the DDR output and output enable paths.

Figure 7-8 shows how a Cyclone IV dedicated write DDIO block is implemented in the I/O element (IOE) registers.

**Figure 7-8. Cyclone IV Dedicated Write DDIO**

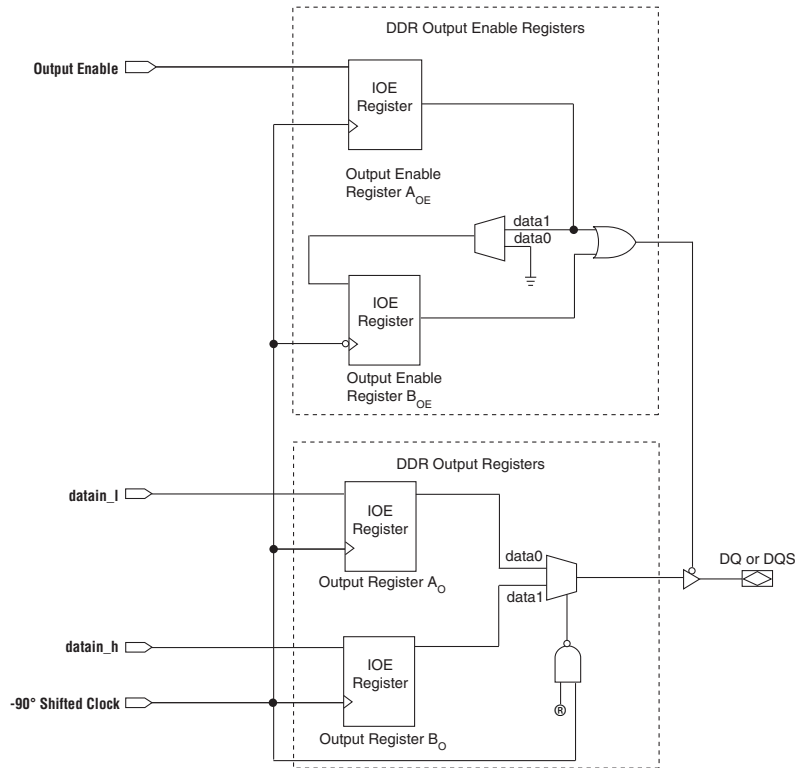

The two DDR output registers are located in the I/O element (IOE) block. Two serial data streams routed through `datain_l` and `datain_h`, are fed into two registers, output register `Ao` and output register `Bo`, respectively, on the same clock edge. The output from output register `Ao` is captured on the falling edge of the clock, while the output from output register `Bo` is captured on the rising edge of the clock. The registered outputs are multiplexed by the common clock to drive the DDR output pin at twice the data rate.

The DDR output enable path has a similar structure to the DDR output path in the IOE block. The second output enable register provides the write preamble for the DQS strobe in DDR external memory interfaces. This active-low output enable register extends the high-impedance state of the pin by half a clock cycle to provide the external memory's DQS write preamble time specification.



For more information about Cyclone IV IOE registers, refer to the [Cyclone IV Device I/O Features](#) chapter.

Figure 7-9 illustrates how the second output enable register extends the DQS high-impedance state by half a clock cycle during a write operation.

**Figure 7-9. Extending the OE Disable by Half a Clock Cycle for a Write Transaction (1)**

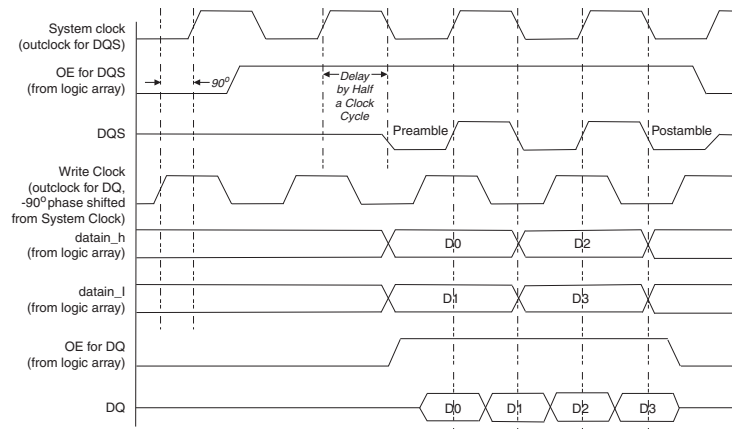

**Note to Figure 7-9:**

- (1) The waveform reflects the software simulation result. The OE signal is an active low on the device. However, the Quartus II software implements the signal as an active high and automatically adds an inverter before the A<sub>OE</sub> register D input.

## OCT with Calibration

Cyclone IV devices support calibrated on-chip series termination (R<sub>S</sub> OCT) in both vertical and horizontal I/O banks. To use the calibrated OCT, you must use the RUP and RDN pins for each R<sub>S</sub> OCT control block (one for each side). You can use each OCT calibration block to calibrate one type of termination with the same V<sub>CCIO</sub> for that given side.

 For more information about the Cyclone IV devices OCT calibration block, refer to the *Cyclone IV Device I/O Features* chapter.

## PLL

When interfacing with external memory, the PLL is used to generate the memory system clock, the write clock, the capture clock and the logic-core clock. The system clock generates the DQS write signals, commands, and addresses. The write-clock is shifted by -90° from the system clock and generates the DQ signals during writes. You can use the PLL reconfiguration feature to calibrate the read-capture phase shift to balance the setup and hold margins.

 The PLL is instantiated in the ALTMEMPHY megafunction. All outputs of the PLL are used when the ALTMEMPHY megafunction is instantiated to interface with external memories. PLL reconfiguration is used in the ALTMEMPHY megafunction to calibrate and track the read-capture phase to maintain the optimum margin.

 For more information about usage of PLL outputs by the ALTMEMPHY megafunction, refer to the *External Memory Interface Handbook*.



For more information about Cyclone IV PLL, refer to the *Clock Networks and PLLs in Cyclone IV Devices* chapter.

## Document Revision History

Table 7-3 lists the revision history for this chapter.

**Table 7-3. Document Revision History**

Date	Version	Changes
March 2016	2.6	<ul style="list-style-type: none"> <li>■ Updated Table 7-1 to remove support for the N148 package.</li> <li>■ Updated note (1) in Figure 7-2 to remove support for the N148 package.</li> <li>■ Updated Figure 7-4 to remove support for the N148 package.</li> </ul>
May 2013	2.5	Updated Table 7-2 to add new device options and packages.
February 2013	2.4	Updated Table 7-2 to add new device options and packages.
October 2012	2.3	Updated Table 7-1 and Table 7-2.
December 2010	2.2	<ul style="list-style-type: none"> <li>■ Updated for the Quartus II software version 10.1 release.</li> <li>■ Added Cyclone IV E new device package information.</li> <li>■ Updated Table 7-2.</li> <li>■ Minor text edits.</li> </ul>
November 2010	2.1	Updated “Data and Data Clock/Strobe Pins” section.
February 2010	2.0	<ul style="list-style-type: none"> <li>■ Added Cyclone IV E devices information for the Quartus II software version 9.1 SP1 release.</li> <li>■ Updated Table 7-1.</li> <li>■ Added Table 7-2.</li> <li>■ Added Figure 7-5 and Figure 7-6.</li> </ul>
November 2009	1.0	Initial release.

This section includes the following chapters:

- [Chapter 8, Configuration and Remote System Upgrades in Cyclone IV Devices](#)
- [Chapter 9, SEU Mitigation in Cyclone IV Devices](#)
- [Chapter 10, JTAG Boundary-Scan Testing for Cyclone IV Devices](#)
- [Chapter 11, Power Requirements for Cyclone IV Devices](#)

### Revision History

Refer to each chapter for its own specific revision history. For information on when each chapter was updated, refer to the Chapter Revision Dates section, which appears in the complete handbook.



This chapter describes the configuration and remote system upgrades in Cyclone® IV devices. Cyclone IV (Cyclone IV GX and Cyclone IV E) devices use SRAM cells to store configuration data. You must download the configuration data to Cyclone IV devices each time the device powers up because SRAM memory is volatile.

Cyclone IV devices are configured using one of the following configuration schemes:

- Active serial (AS)
- Active parallel (AP) (supported in Cyclone IV E devices only)
- Passive serial (PS)
- Fast passive parallel (FPP) (not supported in EP4CGX15, EP4CGX22, and EP4CGX30 [except for the F484 package] devices)
- JTAG

Cyclone IV devices offer the following configuration features:

- Configuration data decompression (“[Configuration Data Decompression](#)” on page 8–2)
- Remote system upgrade (“[Remote System Upgrade](#)” on page 8–69)

System designers face difficult challenges, such as shortened design cycles, evolving standards, and system deployments in remote locations. Cyclone IV devices help overcome these challenges with inherent re-programmability and dedicated circuitry to perform remote system upgrades. Remote system upgrades help deliver feature enhancements and bug fixes without costly recalls, reduced time-to-market, and extended product life.

### Configuration

This section describes Cyclone IV device configuration and includes the following topics:

- “[Configuration Features](#)” on page 8–2
- “[Configuration Requirement](#)” on page 8–3
- “[Configuration Process](#)” on page 8–6
- “[Configuration Scheme](#)” on page 8–8
- “[AS Configuration \(Serial Configuration Devices\)](#)” on page 8–10
- “[AP Configuration \(Supported Flash Memories\)](#)” on page 8–21
- “[PS Configuration](#)” on page 8–32

- “FPP Configuration” on page 8-40
- “JTAG Configuration” on page 8-45
- “Device Configuration Pins” on page 8-62

## Configuration Features

Table 8-1 lists the configuration methods you can use in each configuration scheme.

**Table 8-1. Configuration Features in Cyclone IV Devices**

Configuration Scheme	Configuration Method	Decompression	Remote System Upgrade <sup>(1)</sup>
AS	Serial Configuration Device	✓	✓
AP	Supported Flash Memory <sup>(2)</sup>	—	✓
PS	External Host with Flash Memory	✓	✓ <sup>(3)</sup>
	Download Cable	✓	—
FPP	External Host with Flash Memory	—	✓ <sup>(3)</sup>
JTAG based configuration	External Host with Flash Memory	—	—
	Download Cable	—	—

**Notes to Table 8-1:**

- (1) Remote update mode is supported when you use the Remote System Upgrade feature. You can enable or disable remote update mode with an option setting in the Quartus® II software.
- (2) For more information about the supported device families for the Micron commodity parallel flash, refer to Table 8-10 on page 8-22.
- (3) Remote update mode is supported externally using the Parallel Flash Loader (PFL) with the Quartus II software.

### Configuration Data Decompression

Cyclone IV devices support configuration data decompression, which saves configuration memory space and time. This feature allows you to store compressed configuration data in configuration devices or other memory and send the compressed bitstream to Cyclone IV devices. During configuration, Cyclone IV devices decompress the bitstream in real time and program the SRAM cells.



Compression may reduce the configuration bitstream size by 35 to 55%.

When you enable compression, the Quartus II software generates configuration files with compressed configuration data. This compressed file reduces the storage requirements in the configuration device or flash memory and decreases the time required to send the bitstream to the Cyclone IV device. The time required by a Cyclone IV device to decompress a configuration file is less than the time required to send the configuration data to the device. There are two methods for enabling compression for the Cyclone IV device bitstreams in the Quartus II software:

- Before design compilation (through the Compiler Settings menu)
- After design compilation (through the **Convert Programming Files** dialog box)

To enable compression in the compiler settings of the project in the Quartus II software, perform the following steps:

1. On the Assignments menu, click **Device**. The **Settings** dialog box appears.
2. Click **Device and Pin Options**. The **Device and Pin Options** dialog box appears.

3. Click the **Configuration** tab.
4. Turn on **Generate compressed bitstreams**.
5. Click **OK**.
6. In the **Settings** dialog box, click **OK**.

You can enable compression when creating programming files from the **Convert Programming Files** dialog box. To enable compression, perform the following steps:

1. On the File menu, click **Convert Programming Files**.
2. Under **Output programming file**, select your desired file type from the **Programming file type** list.
3. If you select **Programmer Object File (.pof)**, you must specify the configuration device in the **Configuration device** list.
4. Under **Input files to convert**, select **SOE Data**.
5. Click **Add File** to browse to the Cyclone IV device SRAM object files (.sof).
6. In the **Convert Programming Files** dialog box, select the .pof you added to **SOE Data** and click **Properties**.
7. In the **SOE File Properties** dialog box, turn on the **Compression** option.

When multiple Cyclone IV devices are cascaded, you can selectively enable the compression feature for each device in the chain. [Figure 8-1](#) shows a chain of two Cyclone IV devices. The first device has compression enabled and receives compressed bitstream from the configuration device. The second device has the compression feature disabled and receives uncompressed data. You can generate programming files for this setup in the **Convert Programming Files** dialog box.

**Figure 8-1. Compressed and Uncompressed Configuration Data in the Same Configuration File**

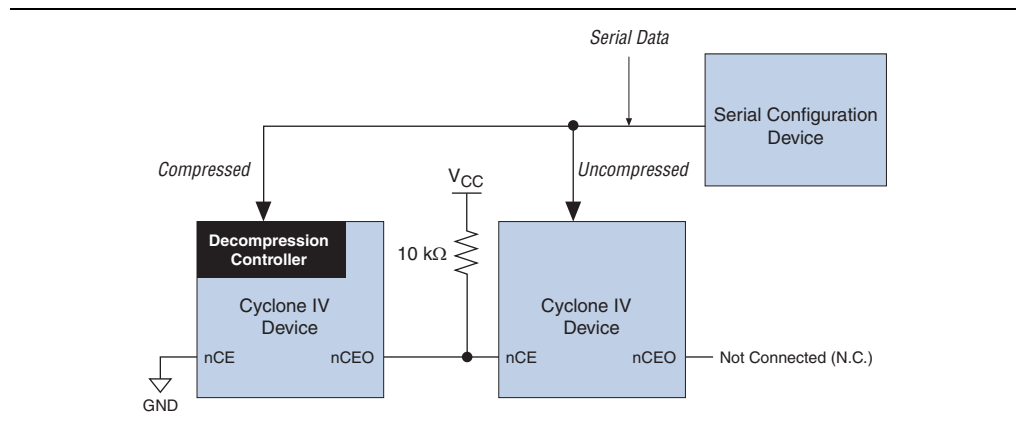

## Configuration Requirement

This section describes Cyclone IV device configuration requirement and includes the following topics:

- [“Power-On Reset \(POR\) Circuit” on page 8-4](#)
- [“Configuration File Size” on page 8-4](#)
- [“Power Up” on page 8-6](#)

## Power-On Reset (POR) Circuit

The POR circuit keeps the device in reset state until the power supply voltage levels have stabilized during device power up. After device power up, the device does not release  $nSTATUS$  until  $V_{CCINT}$ ,  $V_{CCA}$ , and  $V_{CCIO}$  (for I/O banks in which the configuration and JTAG pins reside) are above the POR trip point of the device.  $V_{CCINT}$  and  $V_{CCA}$  are monitored for brown-out conditions after device power up.

  $V_{CCA}$  is the analog power to the phase-locked loop (PLL).

In some applications, it is necessary for a device to wake up very quickly to begin operation. Cyclone IV devices offer the fast POR time option to support fast wake-up time applications. The fast POR time option has stricter power-up requirements when compared with the standard POR time option. You can select either the fast option or the standard POR option with the  $MSEL$  pin settings.

 If your system exceeds the fast or standard POR time, you must hold  $nCONFIG$  low until all the power supplies are stable.

 For more information about the POR specifications, refer to the [Cyclone IV Device Datasheet](#).

 For more information about the wake-up time and POR circuit, refer to the [Power Requirements for Cyclone IV Devices](#) chapter.

## Configuration File Size

Table 8-2 lists the approximate uncompressed configuration file sizes for Cyclone IV devices. To calculate the amount of storage space required for multiple device configurations, add the file size of each device together.

**Table 8-2. Uncompressed Raw Binary File (.rbf) Sizes for Cyclone IV Devices (Part 1 of 2)**

	Device	Data Size (bits)
Cyclone IV E	EP4CE6	2,944,088
	EP4CE10	2,944,088
	EP4CE15	4,086,848
	EP4CE22	5,748,552
	EP4CE30	9,534,304
	EP4CE40	9,534,304
	EP4CE55	14,889,560
	EP4CE75	19,965,752
	EP4CE115	28,571,696

**Table 8–2. Uncompressed Raw Binary File (.rbf) Sizes for Cyclone IV Devices (Part 2 of 2)**

	Device	Data Size (bits)
Cyclone IV GX	EP4CGX15	3,805,568
	EP4CGX22	7,600,040
	EP4CGX30	7,600,040
		22,010,888 <sup>(1)</sup>
	EP4CGX50	22,010,888
	EP4CGX75	22,010,888
	EP4CGX110	39,425,016
	EP4CGX150	39,425,016

**Note to Table 8–2:**

(1) Only for the F484 package.

Use the data in Table 8–2 to estimate the file size before design compilation. Different configuration file formats, such as Hexadecimal (.hex) or Tabular Text File (.tff) formats, have different file sizes. However, for any specific version of the Quartus II software, any design targeted for the same device has the same uncompressed configuration file size. If you use compression, the file size varies after each compilation, because the compression ratio depends on the design.



For more information about setting device configuration options or creating configuration files, refer to the *Software Settings* section in volume 2 of the *Configuration Handbook*.

## Configuration and JTAG Pin I/O Requirements

Cyclone IV devices are manufactured using the TSMC 60-nm low-k dielectric process. Although Cyclone IV devices use TSMC 2.5-V transistor technology in the I/O buffers, the devices are compatible and able to interface with 2.5, 3.0, and 3.3-V configuration voltage standards by following specific requirements.

All I/O inputs must maintain a maximum AC voltage of 4.1 V. When using a serial configuration device in an AS configuration scheme, you must connect a 25-Ω series resistor for the DATA [0] pin. When cascading the Cyclone IV device family in a multi-device configuration for AS, AP, FPP, and PS configuration schemes, you must connect the repeater buffers between the master and slave devices for the DATA and DCLK pins. When using the JTAG configuration scheme in a multi-device configuration, connect 25-Ω resistors on both ends of the TDO-TDI path if the TDO output driver is a non-Cyclone IV device.

The output resistance of the repeater buffers and the TDO path for all cases must fit the maximum overshoot equation shown in Equation 8–1.

**Equation 8–1. <sup>(1)</sup>**

$$0.8Z_O \leq R_E \leq 1.8Z_O$$

**Note to Equation 8–1:**(1)  $Z_O$  is the transmission line impedance and  $R_E$  is the equivalent resistance of the output buffer.

## Configuration Process

This section describes Cyclone IV device configuration requirements and includes the following topics:

- “Power Up” on page 8-6
- “Reset” on page 8-6
- “Configuration” on page 8-6
- “Configuration Error” on page 8-7
- “Initialization” on page 8-7
- “User Mode” on page 8-7

 For more information about the Altera® FPGA configuration cycle state machine, refer to the *Configuring Altera FPGAs* chapter in volume 1 of the *Configuration Handbook*.

### Power Up

If the device is powered up from the power-down state,  $V_{CCINT}$ ,  $V_{CCA}$ , and  $V_{CCIO}$  (for the I/O banks in which the configuration and JTAG pins reside) must be powered up to the appropriate level for the device to exit from POR.

### Reset

After power up, Cyclone IV devices go through POR. POR delay depends on the MSEL pin settings, which correspond to your configuration scheme. During POR, the device resets, holds  $nSTATUS$  and  $CONF\_DONE$  low, and tri-states all user I/O pins (for PS and FPP configuration schemes only).

 To tri-state the configuration bus for AS and AP configuration schemes, you must tie  $nCE$  high and  $nCONFIG$  low.

The user I/O pins and dual-purpose I/O pins have weak pull-up resistors, which are always enabled (after POR) before and during configuration. When the device exits POR, all user I/O pins continue to tri-state. While  $nCONFIG$  is low, the device is in reset. When  $nCONFIG$  goes high, the device exits reset and releases the open-drain  $nSTATUS$  pin, which is then pulled high by an external 10-k $\Omega$  pull-up resistor. After  $nSTATUS$  is released, the device is ready to receive configuration data and the configuration stage starts.

 For more information about the value of the weak pull-up resistors on the I/O pins that are on before and during configuration, refer to the *Cyclone IV Device Datasheet* chapter.

### Configuration

Configuration data is latched into the Cyclone IV device at each DCLK cycle. However, the width of the data bus and the configuration time taken for each scheme are different. After the device receives all the configuration data, the device releases the open-drain  $CONF\_DONE$  pin, which is pulled high by an external 10-k $\Omega$  pull-up resistor. A low-to-high transition on the  $CONF\_DONE$  pin indicates that the configuration is complete and initialization of the device can begin.

You can begin reconfiguration by pulling the `nCONFIG` pin low. The `nCONFIG` pin must be low for at least 500 ns. When `nCONFIG` is pulled low, the Cyclone IV device is reset. The Cyclone IV device also pulls `nSTATUS` and `CONF_DONE` low and all I/O pins are tri-stated. When `nCONFIG` returns to a logic-high level and `nSTATUS` is released by the Cyclone IV device, reconfiguration begins.

### Configuration Error

If an error occurs during configuration, Cyclone IV devices assert the `nSTATUS` signal low, indicating a data frame error and the `CONF_DONE` signal stays low. If the **Auto-restart configuration after error** option (available in the Quartus II software in the **General** tab of the **Device and Pin Options** dialog box) is turned on, the Cyclone IV device releases `nSTATUS` after a reset time-out period (a maximum of 230  $\mu$ s), and retries configuration. If this option is turned off, the system must monitor `nSTATUS` for errors and then pulse `nCONFIG` low for at least 500 ns to restart configuration.

### Initialization

In Cyclone IV devices, the initialization clock source is either the internal oscillator or the optional `CLKUSR` pin. By default, the internal oscillator is the clock source for initialization. If you use the internal oscillator, the device provides itself with enough clock cycles for proper initialization. When using the internal oscillator, you do not have to send additional clock cycles from an external source to the `CLKUSR` pin during the initialization stage. Additionally, you can use the `CLKUSR` pin as a user I/O pin.

You also have the flexibility to synchronize initialization of multiple devices or to delay initialization with the `CLKUSR` option. The `CLKUSR` pin allows you to control when your device enters user mode for an indefinite amount of time. You can turn on the **Enable user-supplied start-up clock (CLKUSR)** option in the Quartus II software in the **General** tab of the **Device and Pin Options** dialog box. When you turn on the **Enable user supplied start-up clock option (CLKUSR)** option, the `CLKUSR` pin is the initialization clock source. Supplying a clock on the `CLKUSR` pin does not affect the configuration process. After the configuration data is accepted and `CONF_DONE` goes high, Cyclone IV devices require 3,192 clock cycles to initialize properly and enter user mode.



If you use the optional `CLKUSR` pin and the `nCONFIG` pin is pulled low to restart configuration during device initialization, ensure that the `CLKUSR` pin continues to toggle when `nSTATUS` is low (a maximum of 230  $\mu$ s).

### User Mode

An optional `INIT_DONE` pin is available, which signals the end of initialization and the start of user mode with a low-to-high transition. The **Enable INIT\_DONE Output** option is available in the Quartus II software in the **General** tab of the **Device and Pin Options** dialog box. If you use the `INIT_DONE` pin, it is high due to an external 10-k $\Omega$  pull-up resistor when `nCONFIG` is low and during the beginning of configuration. After the option bit to enable `INIT_DONE` is programmed into the device (during the first frame of configuration data), the `INIT_DONE` pin goes low. When initialization is complete, the `INIT_DONE` pin is released and pulled high. This low-to-high transition signals that the device has entered user mode. In user mode, the user I/O pins function as assigned in your design and no longer have weak pull-up resistors.

## Configuration Scheme

A configuration scheme with different configuration voltage standards is selected by driving the MSEL pins either high or low, as shown in Table 8-3, Table 8-4, and Table 8-5.



Hardwire the MSEL pins to  $V_{CCA}$  or GND without pull-up or pull-down resistors to avoid problems detecting an incorrect configuration scheme. Do not drive the MSEL pins with a microprocessor or another device.

**Table 8-3. Configuration Schemes for Cyclone IV GX Devices (EP4CGX15, EP4CGX22, and EP4CGX30 [except for F484 Package])**

Configuration Scheme	MSEL2	MSEL1	MSEL0	POR Delay	Configuration Voltage Standard (V) <sup>(1)</sup>
AS	1	0	1	Fast	3.3
	0	1	1	Fast	3.0, 2.5
	0	0	1	Standard	3.3
	0	1	0	Standard	3.0, 2.5
PS	1	0	0	Fast	3.3, 3.0, 2.5
	1	1	0	Fast	1.8, 1.5
	0	0	0	Standard	3.3, 3.0, 2.5
JTAG-based configuration <sup>(2)</sup>	<sup>(3)</sup>	<sup>(3)</sup>	<sup>(3)</sup>	—	—

**Notes to Table 8-3:**

- (1) Configuration voltage standard applied to the  $V_{CCIO}$  supply of the bank in which the configuration pins reside.
- (2) JTAG-based configuration takes precedence over other configuration schemes, which means the MSEL pin settings are ignored.
- (3) Do not leave the MSEL pins floating. Connect them to  $V_{CCA}$  or GND. These pins support the non-JTAG configuration scheme used in production. Altera recommends connecting the MSEL pins to GND if your device is only using JTAG configuration.

**Table 8-4. Configuration Schemes for Cyclone IV GX Devices (EP4CGX30 [only for F484 package], EP4CGX50, EP4CGX75, EP4CGX110, and EP4CGX150) (Part 1 of 2)**

Configuration Scheme	MSEL3	MSEL2	MSEL1	MSEL0	POR Delay	Configuration Voltage Standard (V) <sup>(1)</sup>
AS	1	1	0	1	Fast	3.3
	1	0	1	1	Fast	3.0, 2.5
	1	0	0	1	Standard	3.3
	1	0	1	0	Standard	3.0, 2.5
PS	1	1	0	0	Fast	3.3, 3.0, 2.5
	1	1	1	0	Fast	1.8, 1.5
	1	0	0	0	Standard	3.3, 3.0, 2.5
	0	0	0	0	Standard	1.8, 1.5
FPP	0	0	1	1	Fast	3.3, 3.0, 2.5
	0	1	0	0	Fast	1.8, 1.5
	0	0	0	1	Standard	3.3, 3.0, 2.5
	0	0	1	0	Standard	1.8, 1.5

**Table 8-4. Configuration Schemes for Cyclone IV GX Devices (EP4CGX30 [only for F484 package], EP4CGX50, EP4CGX75, EP4CGX110, and EP4CGX150) (Part 2 of 2)**

Configuration Scheme	MSEL3	MSEL2	MSEL1	MSEL0	POR Delay	Configuration Voltage Standard (V) <sup>(1)</sup>
JTAG-based configuration <sup>(2)</sup>	(3)	(3)	(3)	(3)	—	—

**Notes to Table 8-4:**

- (1) Configuration voltage standard applied to the V<sub>CCIO</sub> supply of the bank in which the configuration pins reside.
- (2) JTAG-based configuration takes precedence over other configuration schemes, which means the MSEL pin settings are ignored.
- (3) Do not leave the MSEL pins floating. Connect them to V<sub>CCA</sub> or GND. These pins support the non-JTAG configuration scheme used in production. Altera recommends connecting the MSEL pins to GND if your device is only using JTAG configuration.

 Smaller Cyclone IV E devices or package options (E144 and F256 packages) do not have the MSEL[3] pin. The AS Fast POR configuration scheme at 3.0- or 2.5-V configuration voltage standard and the AP configuration scheme are not supported in Cyclone IV E devices without the MSEL[3] pin. To configure these devices with other supported configuration schemes, select MSEL[2..0] pins according to the MSEL settings in Table 8-5.

**Table 8-5. Configuration Schemes for Cyclone IV E Devices**

Configuration Scheme	MSEL3	MSEL2	MSEL1	MSEL0	POR Delay	Configuration Voltage Standard (V) <sup>(1)</sup>
AS	1	1	0	1	Fast	3.3
	0	1	0	0	Fast	3.0, 2.5
	0	0	1	0	Standard	3.3
	0	0	1	1	Standard	3.0, 2.5
AP	0	1	0	1	Fast	3.3
	0	1	1	0	Fast	1.8
	0	1	1	1	Standard	3.3
	1	0	1	1	Standard	3.0, 2.5
	1	0	0	0	Standard	1.8
PS	1	1	0	0	Fast	3.3, 3.0, 2.5
	0	0	0	0	Standard	3.3, 3.0, 2.5
FPP	1	1	1	0	Fast	3.3, 3.0, 2.5
	1	1	1	1	Fast	1.8, 1.5
JTAG-based configuration <sup>(2)</sup>	(3)	(3)	(3)	(3)	—	—

**Notes to Table 8-5:**

- (1) Configuration voltage standard applied to the V<sub>CCIO</sub> supply of the bank in which the configuration pins reside.
- (2) JTAG-based configuration takes precedence over other configuration schemes, which means the MSEL pin settings are ignored.
- (3) Do not leave the MSEL pins floating. Connect them to V<sub>CCA</sub> or GND. These pins support the non-JTAG configuration scheme used in production. Altera recommends connecting the MSEL pins to GND if your device is only using JTAG configuration.

 For Cyclone IV E devices, the Quartus II software prohibits you from using the LVDS I/O standard in I/O Bank 1 when the configuration device I/O voltage is not 2.5 V. If you need to assign LVDS I/O standard in I/O Bank 1, navigate to **Assignments>Device>Settings>Device and Pin Option>Configuration** to change the Configuration Device I/O voltage to 2.5 V or Auto.

## AS Configuration (Serial Configuration Devices)

In the AS configuration scheme, Cyclone IV devices are configured with a serial configuration device. These configuration devices are low-cost devices with non-volatile memories that feature a simple four-pin interface and a small form factor. These features make serial configuration devices the ideal low-cost configuration solution.

 For more information about serial configuration devices, refer to the *Serial Configuration Devices (EPCS1, EPCS4, EPCS16, EPCS64, and EPCS128) Datasheet* in volume 2 of the *Configuration Handbook*.

Serial configuration devices provide a serial interface to access the configuration data. During device configuration, Cyclone IV devices read the configuration data through the serial interface, decompress the data if necessary, and configure their SRAM cells. This scheme is referred to as the AS configuration scheme because the device controls the configuration interface.

 If you want to gain control of the EPCS pins, hold the  $n$ CONFIG pin low and pull the  $n$ CE pin high to cause the device to reset and tri-state the AS configuration pins.

### Single-Device AS Configuration

The four-pin interface of serial configuration devices consists of the following pins:

- Serial clock input (DCLK)
- Serial data output (DATA)
- Active-low chip select ( $n$ CS)
- AS data input (ASDI)

This four-pin interface connects to Cyclone IV device pins, as shown in [Figure 8-2](#).

**Figure 8-2. Single-Device AS Configuration**

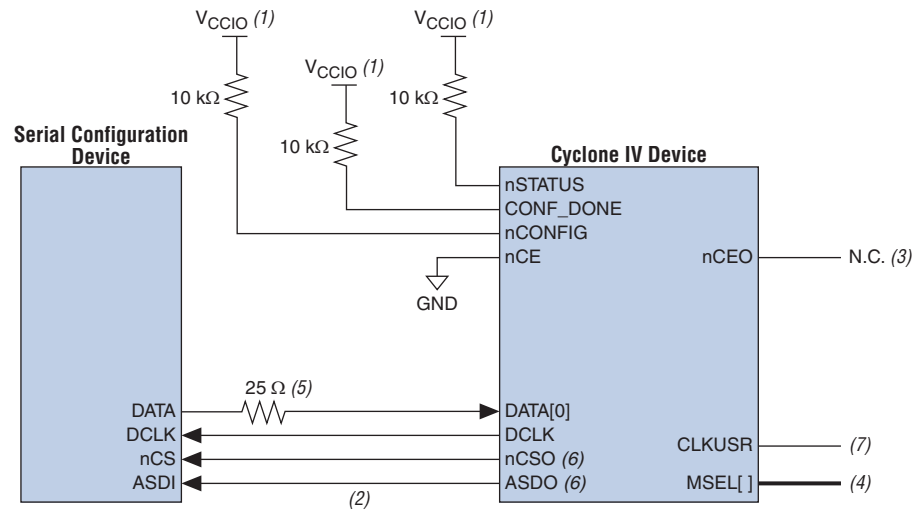

**Notes to Figure 8-2:**

- (1) Connect the pull-up resistors to the  $V_{CCIO}$  supply of the bank in which the pin resides.
- (2) Cyclone IV devices use the ASDO-to-ASDI path to control the configuration device.
- (3) The nCEO pin is left unconnected or used as a user I/O pin when it does not feed the nCE pin of another device.
- (4) The MSEL pin settings vary for different configuration voltage standards and POR time. To connect the MSEL pins, refer to [Table 8-3 on page 8-8](#), [Table 8-4 on page 8-8](#), and [Table 8-5 on page 8-9](#). Connect the MSEL pins directly to  $V_{CCA}$  or GND.
- (5) Connect the series resistor at the near end of the serial configuration device.
- (6) These pins are dual-purpose I/O pins. The nCSO pin functions as FLASH\_nCE pin in AP mode. The ASDO pin functions as the DATA[1] pin in AP and FPP modes.
- (7) Only Cyclone IV GX devices have an option to select CLKUSR (40 MHz maximum) as the external clock source for DCLK.

 To tri-state the configuration bus for AS configuration schemes, you must tie nCE high and nCONFIG low.

 The 25-Ω resistor at the near end of the serial configuration device for DATA[0] works to minimize the driver impedance mismatch with the board trace and reduce the overshoot seen at the Cyclone IV device DATA[0] input pin.

In the single-device AS configuration, the maximum board loading and board trace length between the supported serial configuration device and the Cyclone IV device must follow the recommendations in [Table 8-7 on page 8-18](#).

The DCLK generated by the Cyclone IV device controls the entire configuration cycle and provides timing for the serial interface. Cyclone IV devices use an internal oscillator or an external clock source to generate the DCLK. For Cyclone IV E devices, you can use a 40-MHz internal oscillator to generate the DCLK and for Cyclone IV GX devices you can use a slow clock (20 MHz maximum) or a fast clock (40 MHz maximum) from the internal oscillator or an external clock from CLKUSR to generate the DCLK. There are some variations in the internal oscillator frequency because of the process, voltage, and temperature (PVT) conditions in Cyclone IV

devices. The internal oscillator is designed to ensure that its maximum frequency is guaranteed to meet EPCS device specifications. Cyclone IV devices offer the option to select `CLKUSR` as the external clock source for `DCLK`. You can change the clock source option in the Quartus II software in the **Configuration** tab of the **Device and Pin Options** dialog box.



EPCS1 does not support Cyclone IV devices because of its insufficient memory capacity.

**Table 8-6. AS DCLK Output Frequency**

Oscillator	Minimum	Typical	Maximum	Unit
40 MHz	20	30	40	MHz

In configuration mode, the Cyclone IV device enables the serial configuration device by driving the `nCS0` output pin low, which connects to the `nCS` pin of the configuration device. The Cyclone IV device uses the `DCLK` and `DATA [1]` pins to send operation commands and read address signals to the serial configuration device. The configuration device provides data on its `DATA` pin, which connects to the `DATA [0]` input of the Cyclone IV device.

All AS configuration pins (`DATA [0]`, `DCLK`, `nCS0`, and `DATA [1]`) have weak internal pull-up resistors that are always active. After configuration, these pins are set as input tri-stated and are driven high by the weak internal pull-up resistors.

The timing parameters for AS mode are not listed here because the  $t_{CF2CD}$ ,  $t_{CF2ST0}$ ,  $t_{CFG}$ ,  $t_{STATUS}$ ,  $t_{CF2ST1}$ , and  $t_{CD2UM}$  timing parameters are identical to the timing parameters for PS mode shown in [Table 8-12 on page 8-36](#).

## Multi-Device AS Configuration

You can configure multiple Cyclone IV devices with a single serial configuration device. When the first device captures all its configuration data from the bitstream, it drives the  $nCE0$  pin low, enabling the next device in the chain. If the last device in the chain is a Cyclone IV device, you can leave the  $nCE0$  pin of the last device unconnected or use it as a user I/O pin after configuration. The  $nCONFIG$ ,  $nSTATUS$ ,  $CONF\_DONE$ ,  $DCLK$ , and  $DATA[0]$  pins of each device in the chain are connected together (Figure 8-3).

Figure 8-3. Multi-Device AS Configuration

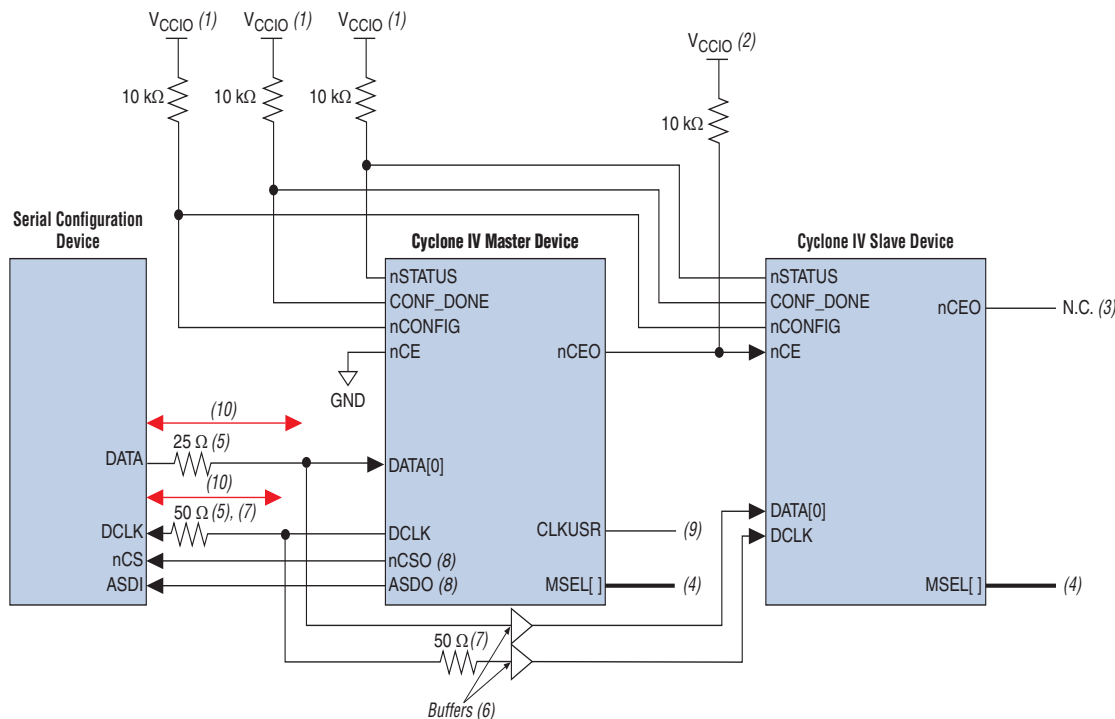

### Notes to Figure 8-3:

- (1) Connect the pull-up resistors to the  $V_{CCIO}$  supply of the bank in which the pin resides.
- (2) Connect the pull-up resistor to the  $V_{CCIO}$  supply voltage of I/O bank in which the  $nCE$  pin resides.
- (3) You can leave the  $nCEO$  pin unconnected or use it as a user I/O pin when it does not feed the  $nCE$  pin of another device.
- (4) The  $MSEL$  pin settings vary for different configuration voltage standards and POR time. You must set the master device of the Cyclone IV device in AS mode and the slave devices in PS mode. To connect the  $MSEL$  pins for the master device in AS mode and slave devices in PS mode, refer to Table 8-3 on page 8-8, Table 8-4 on page 8-8, and Table 8-5 on page 8-9. Connect the  $MSEL$  pins directly to  $V_{CCA}$  or GND.
- (5) Connect the series resistor at the near end of the serial configuration device.
- (6) Connect the repeater buffers between the master and slave devices of the Cyclone IV device for  $DATA[0]$  and  $DCLK$ . All I/O inputs must maintain a maximum AC voltage of 4.1 V. The output resistance of the repeater buffers must fit the maximum overshoot equation outlined in “Configuration and JTAG Pin I/O Requirements” on page 8-5.
- (7) The 50- $\Omega$  series resistors are optional if the 3.3-V configuration voltage standard is applied. For optimal signal integrity, connect these 50- $\Omega$  series resistors if the 2.5- or 3.0-V configuration voltage standard is applied.
- (8) These pins are dual-purpose I/O pins. The  $nCS0$  pin functions as  $FLASH\_nCE$  pin in AP mode. The  $ASDO$  pin functions as  $DATA[1]$  pin in AP and FPP modes.
- (9) Only Cyclone IV GX devices have an option to select  $CLKUSR$  (40 MHz maximum) as the external clock source for  $DCLK$ .
- (10) For multi-devices AS configuration using Cyclone IV E with 1.0 V core voltage, the maximum board trace-length from the serial configuration device to the junction-split on both  $DCLK$  and  $Data0$  line is 3.5 inches.

The first Cyclone IV device in the chain is the configuration master and it controls the configuration of the entire chain. Other Altera devices that support PS configuration can also be part of the chain as configuration slaves.

 In the multi-device AS configuration, the board trace length between the serial configuration device and the master device of the Cyclone IV device must follow the recommendations in [Table 8-7 on page 8-18](#).

The `nSTATUS` and `CONF_DONE` pins on all target devices are connected together with external pull-up resistors, as shown in [Figure 8-3 on page 8-13](#). These pins are open-drain bidirectional pins on the devices. When the first device asserts `nCEO` (after receiving all its configuration data), it releases its `CONF_DONE` pin. However, the subsequent devices in the chain keep this shared `CONF_DONE` line low until they receive their configuration data. When all target devices in the chain receive their configuration data and release `CONF_DONE`, the pull-up resistor drives a high level on `CONF_DONE` line and all devices simultaneously enter initialization mode.

 Although you can cascade Cyclone IV devices, serial configuration devices cannot be cascaded or chained together.

If the configuration bitstream size exceeds the capacity of a serial configuration device, you must select a larger configuration device, enable the compression feature, or both. When configuring multiple devices, the size of the bitstream is the sum of the individual device's configuration bitstream.

## Configuring Multiple Cyclone IV Devices with the Same Design

Certain designs require that you configure multiple Cyclone IV devices with the same design through a configuration bitstream, or a `.sof`. You can do this through the following methods:

- Multiple `.sof`
- Single `.sof`

 For both methods, the serial configuration devices cannot be cascaded or chained together.

### Multiple SRAM Object Files

Two copies of the `.sof` are stored in the serial configuration device. Use the first copy to configure the master device of the Cyclone IV device and the second copy to configure all remaining slave devices concurrently. All slave devices must have the same density and package. The setup is similar to [Figure 8-3 on page 8-13](#).

To configure four identical Cyclone IV devices with the same `.sof`, you must set up the chain similar to the example shown in [Figure 8-4](#). The first device is the master device and its `MSEL` pins must be set to select AS configuration. The other three slave devices are set up for concurrent configuration and their `MSEL` pins must be set to select PS configuration. The `nCEO` pin from the master device drives the `nCE` input pins on all three slave devices, as well as the `DATA` and `DCLK` pins that connect in parallel to all

four devices. During the first configuration cycle, the master device reads its configuration data from the serial configuration device while holding `nCEO` high. After completing its configuration cycle, the master device drives `nCE` low and sends the second copy of the configuration data to all three slave devices, configuring them simultaneously.

The advantage of the setup in [Figure 8-4](#) is that you can have a different `.sof` for the master device. However, all the slave devices must be configured with the same `.sof`. You can either compress or uncompress the `.sof` in this configuration method.

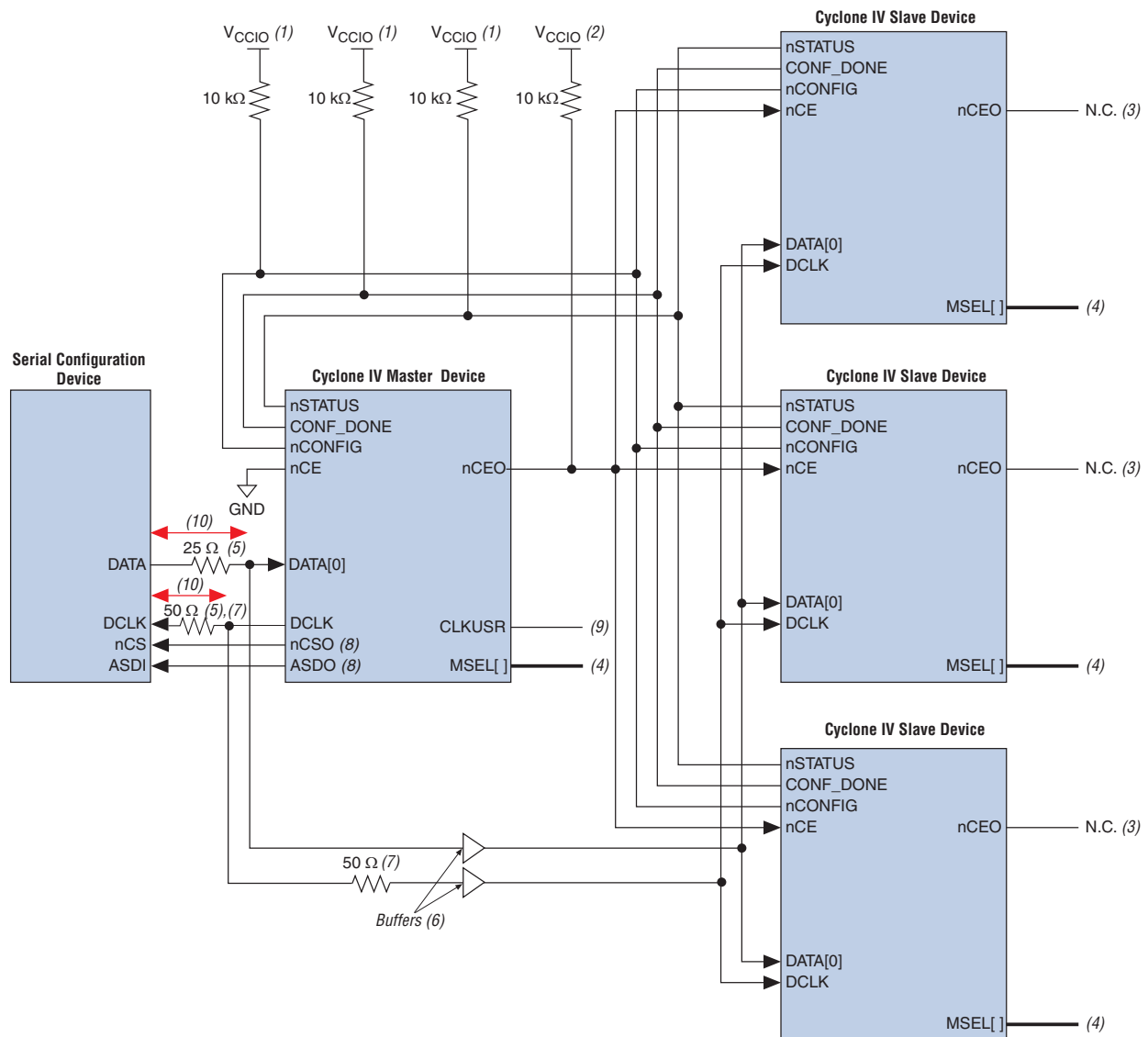

You can still use this method if the master and slave devices use the same `.sof`.

**Figure 8-4. Multi-Device AS Configuration in Which Devices Receive the Same Data with Multiple .sof****Notes to Figure 8-4:**

- (1) Connect the pull-up resistors to the  $V_{CCIO}$  supply of the bank in which the pin resides.
- (2) Connect the pull-up resistor to the  $V_{CCIO}$  supply voltage of the I/O bank in which the  $nCE$  pin resides.
- (3) The  $nCEO$  pin is left unconnected or used as a user I/O pin when it does not feed the  $nCE$  pin of another device.
- (4) The  $MSEL$  pin settings vary for different configuration voltage standards and POR time. You must set the master device in AS mode and the slave devices in PS mode. To connect the  $MSEL$  pins for the master device in AS mode and the slave devices in PS mode, refer to [Table 8-3 on page 8-8](#), [Table 8-4 on page 8-8](#), and [Table 8-5 on page 8-9](#). Connect the  $MSEL$  pins directly to  $V_{CCA}$  or GND.
- (5) Connect the series resistor at the near end of the serial configuration device.
- (6) Connect the repeater buffers between the master and slave devices for  $DATA[0]$  and  $DCLK$ . All I/O inputs must maintain a maximum AC voltage of 4.1 V. The output resistance of the repeater buffers must fit the maximum overshoot equation outlined in “[Configuration and JTAG Pin I/O Requirements](#)” on page 8-5.
- (7) The 50- $\Omega$  series resistors are optional if the 3.3-V configuration voltage standard is applied. For optimal signal integrity, connect these 50- $\Omega$  series resistors if the 2.5- or 3.0-V configuration voltage standard is applied.
- (8) These pins are dual-purpose I/O pins. The  $nCSO$  pin functions as  $FLASH\_nCE$  pin in AP mode. The  $ASDO$  pin functions as  $DATA[1]$  pin in AP and FPP modes.
- (9) Only Cyclone IV GX devices have an option to select  $CLKUSR$  (40 MHz maximum) as the external clock source for  $DCLK$ .
- (10) For multi-devices AS configuration using Cyclone IV E with 1.0 V core voltage, the maximum board trace-length from the serial configuration device to the junction-split on both  $DCLK$  and  $Data0$  line is 3.5 inches.

### Single SRAM Object File

The second method configures both the master device and slave devices with the same .sof. The serial configuration device stores one copy of the .sof. You must set up one or more slave devices in the chain. All the slave devices must be set up in the same way (Figure 8-5).

**Figure 8-5. Multi-Device AS Configuration in Which Devices Receive the Same Data with a Single .sof**

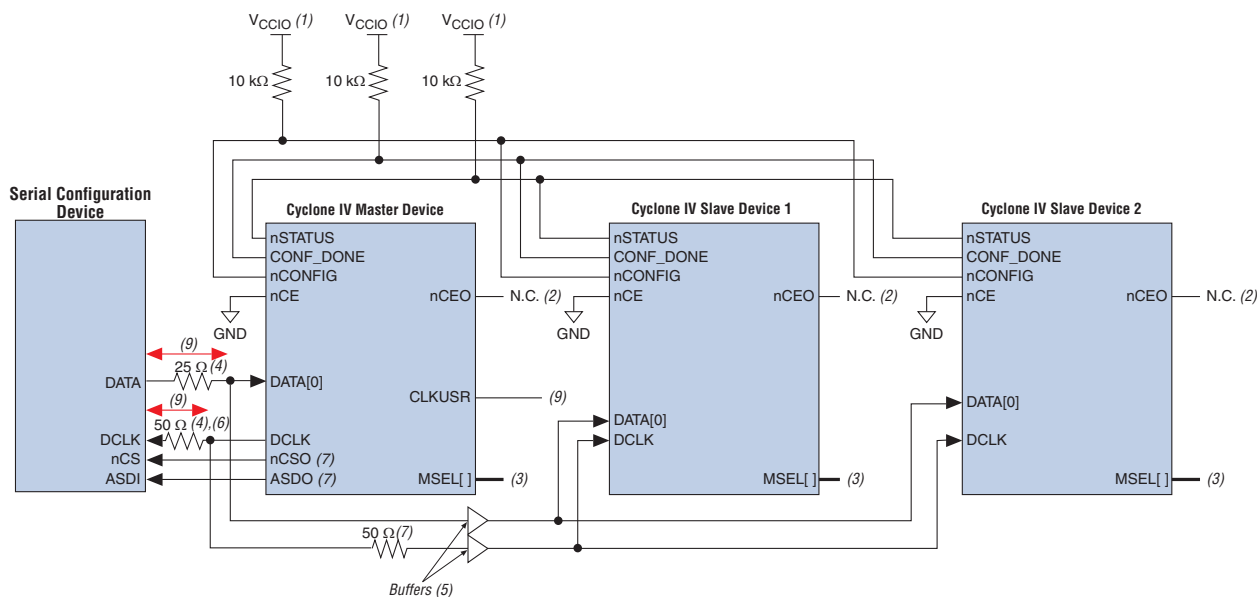

#### Notes to Figure 8-5:

- (1) Connect the pull-up resistors to the  $V_{CCIO}$  supply of the bank in which the pin resides.
- (2) The  $nCEO$  pin is left unconnected or used as a user I/O pin when it does not feed the  $nCE$  pin of another device.
- (3) The  $MSEL$  pin settings vary for different configuration voltage standards and POR time. You must set the master device of the Cyclone IV device in AS mode and the slave devices in PS mode. To connect the  $MSEL$  pins for the master device in AS mode and slave devices in PS mode, refer to Table 8-3 on page 8-8, Table 8-4 on page 8-8, and Table 8-5 on page 8-9. Connect the  $MSEL$  pins directly to  $V_{CCA}$  or GND.
- (4) Connect the series resistor at the near end of the serial configuration device.
- (5) Connect the repeater buffers between the master and slave devices for  $DATA[0]$  and  $DCLK$ . All I/O inputs must maintain a maximum AC voltage of 4.1 V. The output resistance of the repeater buffers must fit the maximum overshoot equation outlined in “Configuration and JTAG Pin I/O Requirements” on page 8-5.
- (6) The 50- $\Omega$  series resistors are optional if the 3.3-V configuration voltage standard is applied. For optimal signal integrity, connect these 50- $\Omega$  series resistors if the 2.5- or 3.0-V configuration voltage standard is applied.
- (7) These pins are dual-purpose I/O pins. The  $nCSO$  pin functions as  $FLASH\_nCE$  pin in AP mode. The  $ASDO$  pin functions as  $DATA[1]$  pin in AP and FPP modes.
- (8) Only Cyclone IV GX devices have an option to select  $CLKUSR$  (40 MHz maximum) as the external clock source for  $DCLK$ .
- (9) For multi-devices AS configuration using Cyclone IV E with 1.0 V core voltage, the maximum board trace-length from the serial configuration device to the junction-split on both  $DCLK$  and  $Data0$  line is 3.5 inches.

In this setup, all the Cyclone IV devices in the chain are connected for concurrent configuration. This reduces the AS configuration time because all the Cyclone IV devices are configured in one configuration cycle. Connect the  $nCE$  input pins of all the Cyclone IV devices to GND. You can either leave the  $nCEO$  output pins on all the Cyclone IV devices unconnected or use the  $nCEO$  output pins as normal user I/O pins. The  $DATA$  and  $DCLK$  pins are connected in parallel to all the Cyclone IV devices.

Altera recommends putting a buffer before the DATA and DCLK output from the master device to avoid signal strength and signal integrity issues. The buffer must not significantly change the DATA-to-DCLK relationships or delay them with respect to other AS signals (ASDI and nCS). Also, the buffer must only drive the slave devices to ensure that the timing between the master device and the serial configuration device is unaffected.

This configuration method supports both compressed and uncompressed .sof. Therefore, if the configuration bitstream size exceeds the capacity of a serial configuration device, you can enable the compression feature in the .sof or you can select a larger serial configuration device.

### Guidelines for Connecting a Serial Configuration Device to Cyclone IV Devices for an AS Interface

For single- and multi-device AS configurations, the board trace length and loading between the supported serial configuration device and Cyclone IV device must follow the recommendations listed in [Table 8-7](#).

**Table 8-7. Maximum Trace Length and Loading for AS Configuration**

Cyclone IV Device AS Pins	Maximum Board Trace Length from a Cyclone IV Device to a Serial Configuration Device (Inches)		Maximum Board Load (pF)
	Cyclone IV E	Cyclone IV GX	
DCLK	10	6	15
DATA [0]	10	6	30
nCSO	10	6	30
ASDO	10	6	30

**Note to [Table 8-7](#):**

- (1) For multi-devices AS configuration using Cyclone IV E with 1.0 V core voltage, the maximum board trace-length from the serial configuration device to the junction-split on both DCLK and Data0 line is 3.5 inches.

### Estimating AS Configuration Time

AS configuration time is dominated by the time it takes to transfer data from the serial configuration device to the Cyclone IV device. This serial interface is clocked by the Cyclone IV device DCLK output (generated from a 40-MHz internal oscillator for Cyclone IV E devices, a 20- or 40-MHz internal oscillator, or an external CLKUSR of up to 40 MHz for Cyclone IV GX devices).

[Equation 8-2](#) and [Equation 8-3](#) show the configuration time calculations.

**Equation 8-2.**

$$\text{Size} \times \left( \frac{\text{maximum DCLK period}}{1 \text{ bit}} \right) = \text{estimated maximum configuration time}$$

**Equation 8-3.**

$$9,600,000 \text{ bits} \times \left( \frac{50 \text{ ns}}{1 \text{ bit}} \right) = 480 \text{ ms}$$

Table 8-8 provides the configuration time for AS configuration.

**Table 8-8. AS Configuration Time for Cyclone IV Devices <sup>(1)</sup>**

Symbol	Parameter	Cyclone IV E	Cyclone IV GX	Unit
$t_{SU}$	Setup time	10	8	ns
$t_H$	Hold time	0	0	ns
$t_{CO}$	Clock-to-output time	4	4	ns

**Note to Table 8-8:**

(1) For the AS configuration timing diagram, refer to the *Serial Configuration (EPCS) Devices Datasheet*.

Enabling compression reduces the amount of configuration data that is sent to the Cyclone IV device, which also reduces configuration time. On average, compression reduces configuration time by 50%.

## Programming Serial Configuration Devices

Serial configuration devices are non-volatile, flash memory-based devices. You can program these devices in-system with the USB-Blaster™ or ByteBlaster™ II download cables. Alternatively, you can program them with the Altera Programming Unit (APU), supported third-party programmers, or a microprocessor with the SRrunner software driver.

You can perform in-system programming of serial configuration devices through the AS programming interface. During in-system programming, the download cable disables device access to the AS interface by driving the nCE pin high. Cyclone IV devices are also held in reset by a low level on nCONFIG. After programming is complete, the download cable releases nCE and nCONFIG, allowing the pull-down and pull-up resistors to drive V<sub>CC</sub> and GND, respectively.

To perform in-system programming of a serial configuration device through the AS programming interface, you must place the diodes and capacitors as close as possible to the Cyclone IV device. You must ensure that the diodes and capacitors maintain a maximum AC voltage of 4.1 V (Figure 8-6).

 If you want to use the setup shown in Figure 8-6 to perform in-system programming of a serial configuration device and single- or multi-device AS configuration, you do not require a series resistor on the DATA line at the near end of the serial configuration device. The existing diodes and capacitors are sufficient.

Altera has developed the Serial FlashLoader (SFL), a JTAG-based in-system programming solution for Altera serial configuration devices. The SFL is a bridge design for the Cyclone IV device that uses its JTAG interface to access the EPCS JIC (JTAG Indirect Configuration Device Programming) file and then uses the AS interface to program the EPCS device. Both the JTAG interface and AS interface are bridged together inside the SFL design.

 For more information about implementing the SFL with Cyclone IV devices, refer to *AN 370: Using the Serial FlashLoader with the Quartus II Software*.

For more information about the USB-Blaster download cable, refer to the *USB-Blaster Download Cable User Guide*. For more information about the ByteBlaster II download cable, refer to the *ByteBlaster II Download Cable User Guide*.

Figure 8-6 shows the download cable connections to the serial configuration device.

**Figure 8-6. In-System Programming of Serial Configuration Devices**

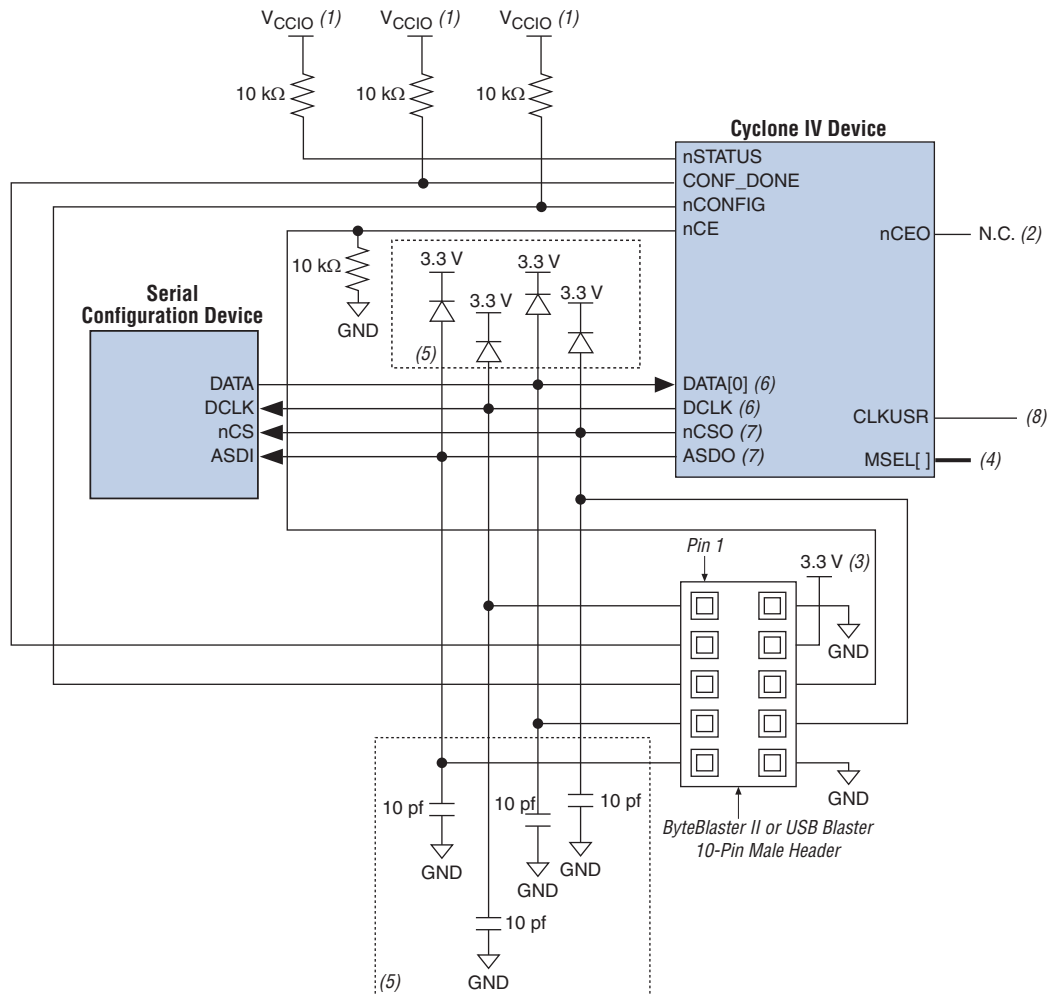

**Notes to Figure 8-6:**

- (1) Connect these pull-up resistors to the V<sub>CCIO</sub> supply of the bank in which the pin resides.
- (2) The nCEO pin is left unconnected or used as a user I/O pin when it does not feed the nCE pin of another device.
- (3) Power up the V<sub>CC</sub> of the ByteBlaster II or USB-Blaster download cable with the 3.3-V supply.
- (4) The MSEL pin settings vary for different configuration voltage standards and POR time. To connect the MSEL pins, refer to [Table 8-3 on page 8-8](#), [Table 8-4 on page 8-8](#), and [Table 8-5 on page 8-9](#). Connect the MSEL pins directly to V<sub>CCA</sub> or GND.
- (5) The diodes and capacitors must be placed as close as possible to the Cyclone IV device. You must ensure that the diodes and capacitors maintain a maximum AC voltage of 4.1 V. The external diodes and capacitors are required to prevent damage to the Cyclone IV device AS configuration input pins due to possible overshoot when programming the serial configuration device with a download cable. Altera recommends using the Schottky diode, which has a relatively lower forward diode voltage (VF) than the switching and Zener diodes, for effective voltage clamping.
- (6) When cascading Cyclone IV devices in a multi-device AS configuration, connect the repeater buffers between the master and slave devices for DATA[0] and DCLK. All I/O inputs must maintain a maximum AC voltage of 4.1 V. The output resistance of the repeater buffers must fit the maximum overshoot equation outlined in “[Configuration and JTAG Pin I/O Requirements](#)” on page 8-5.
- (7) These pins are dual-purpose I/O pins. The nCSO pin functions as FLASH\_nCE pin in AP mode. The ASDO pin functions as DATA[1] pin in AP and FPP modes.
- (8) Only Cyclone IV GX devices have an option to select CLKUSR (40 MHz maximum) as the external clock source for DCLK.

You can use the Quartus II software with the APU and the appropriate configuration device programming adapter to program serial configuration devices. All serial configuration devices are offered in an 8- or 16-pin small outline integrated circuit (SOIC) package.

In production environments, serial configuration devices are programmed using multiple methods. Altera programming hardware or other third-party programming hardware is used to program blank serial configuration devices before they are mounted onto PCBs. Alternatively, you can use an on-board microprocessor to program the serial configuration device in-system by porting the reference C-based SRunner software driver provided by Altera.

A serial configuration device is programmed in-system by an external microprocessor with the SRunner software driver. The SRunner software driver is a software driver developed for embedded serial configuration device programming, which is easily customized to fit in different embedded systems. The SRunner software driver is able to read a Raw Programming Data (.rpd) file and write to serial configuration devices. The serial configuration device programming time, using the SRunner software driver, is comparable to the programming time with the Quartus II software.



For more information about the SRunner software driver, refer to [AN 418: SRunner: An Embedded Solution for Serial Configuration Device Programming](#) and the source code at the Altera website.

## AP Configuration (Supported Flash Memories)

The AP configuration scheme is only supported in Cyclone IV E devices. In the AP configuration scheme, Cyclone IV E devices are configured using commodity 16-bit parallel flash memory. These external non-volatile configuration devices are industry standard microprocessor flash memories. The flash memories provide a fast interface to access configuration data. The speed up in configuration time is mainly due to the 16-bit wide parallel data bus, which is used to retrieve data from the flash memory.

Some of the smaller Cyclone IV E devices or package options do not support the AP configuration scheme. [Table 8-9](#) lists the supported AP configuration scheme for each Cyclone IV E devices.

**Table 8-9. Supported AP Configuration Scheme for Cyclone IV E Devices**

Device	Package Options								
	E144	M164	M256	U256	F256	F324	U484	F484	F780
EP4CE6	—	—	—	—	—	—	—	—	—
EP4CE10	—	—	—	—	—	—	—	—	—
EP4CE15	—	—	—	—	—	—	—	✓	—
EP4CE22	—	—	—	—	—	—	—	—	—
EP4CE30	—	—	—	—	—	✓	—	✓	✓
EP4CE40	—	—	—	—	—	✓	✓	✓	✓
EP4CE55	—	—	—	—	—	—	✓	✓	✓
EP4CE75	—	—	—	—	—	—	✓	✓	✓
EP4CE115	—	—	—	—	—	—	—	✓	✓

During device configuration, Cyclone IV E devices read configuration data using the parallel interface and configure their SRAM cells. This scheme is referred to as the AP configuration scheme because the device controls the configuration interface. This scheme contrasts with the FPP configuration scheme, where an external host controls the interface.

## AP Configuration Supported Flash Memories

The AP configuration controller in Cyclone IV E devices is designed to interface with two industry-standard flash families—the Micron P30 Parallel NOR flash family and the Micron P33 Parallel NOR flash family. Unlike serial configuration devices, both of the flash families supported in AP configuration scheme are designed to interface with microprocessors. By configuring from an industry standard microprocessor flash which allows access to the flash after entering user mode, the AP configuration scheme allows you to combine configuration data and user data (microprocessor boot code) on the same flash memory.

The Micron P30 flash family and the P33 flash family support a continuous synchronous burst read mode at 40 MHz DCLK frequency for reading data from the flash. Additionally, the Micron P30 and P33 flash families have identical pin-out and adopt similar protocols for data access.



Cyclone IV E devices use a 40-MHz oscillator for the AP configuration scheme. The oscillator is the same oscillator used in the Cyclone IV E AS configuration scheme.

Table 8-10 lists the supported families of the commodity parallel flash for the AP configuration scheme.

**Table 8-10. Supported Commodity Flash for AP Configuration Scheme for Cyclone IV E Devices <sup>(1)</sup>**

Flash Memory Density	Micron P30 Flash Family <sup>(2)</sup>	Micron P33 Flash Family <sup>(3)</sup>
64 Mbit	✓	✓
128 Mbit	✓	✓
256 Mbit	✓	✓

### Notes to Table 8-10:

- (1) The AP configuration scheme only supports flash memory speed grades of 40 MHz and above.
- (2) 3.3-, 3.0-, 2.5-, and 1.8-V I/O options are supported for the Micron P30 flash family.
- (3) 3.3-, 3.0- and 2.5-V I/O options are supported for the Micron P33 flash family.

Configuring Cyclone IV E devices from the Micron P30 and P33 family 512-Mbit flash memory is possible, but you must properly drive the extra address and FLASH\_nCE pins as required by these flash memories.



To check for supported speed grades and package options, refer to the respective flash datasheets.

The AP configuration scheme in Cyclone IV E devices supports flash speed grades of 40 MHz and above. However, AP configuration for all these speed grades must be capped at 40 MHz. The advantage of faster speed grades is realized when your design in the Cyclone IV E devices accesses flash memory in user mode.

- For more information about the operation of the Micron P30 Parallel NOR and P33 Parallel NOR flash memories, search for the keyword “P30” or “P33” on the Micron website ([www.micron.com](http://www.micron.com)) to obtain the P30 or P33 family datasheet.

## Single-Device AP Configuration

The following groups of interface pins are supported in Micron P30 and P33 flash memories:

- Control pins
- Address pins
- Data pins

The following control signals are from the supported parallel flash memories:

- CLK
- active-low reset (RST#)
- active-low chip enable (CE#)
- active-low output enable (OE#)
- active-low address valid (ADV#)
- active-low write enable (WE#)

The supported parallel flash memories output a control signal (WAIT) to Cyclone IV E devices to indicate when synchronous data is ready on the data bus. Cyclone IV E devices have a 24-bit address bus connecting to the address bus (A[24:1]) of the flash memory. A 16-bit bidirectional data bus (DATA[15..0]) provides data transfer between the Cyclone IV E device and the flash memory.

The following control signals are from the Cyclone IV E device to flash memory:

- DCLK
- active-low hard rest (nRESET)
- active-low chip enable (FLASH\_nCE)
- active-low output enable for the DATA[15..0] bus and WAIT pin (nOE)
- active-low address valid signal and is used to write data into the flash (nAVD)
- active-low write enable and is used to write data into the flash (nWE)

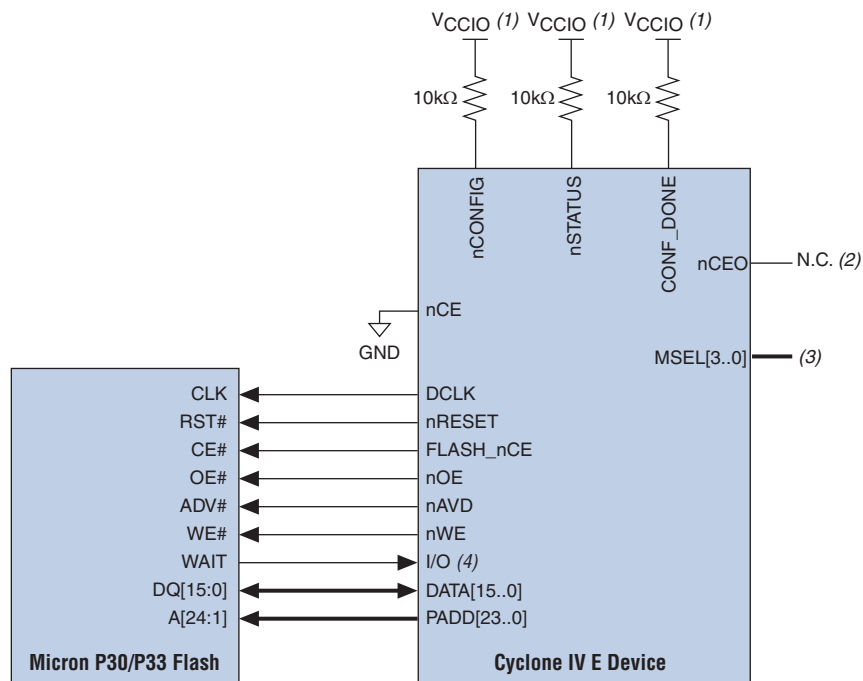

Figure 8-7 shows the interface for the Micron P30 flash memory and P33 flash memory to the Cyclone IV E device pins.

**Figure 8-7. Single-Device AP Configuration Using Micron P30 and P33 Flash Memory**



**Notes to Figure 8-7:**

- (1) Connect the pull-up resistors to the  $V_{CCIO}$  supply of the bank in which the pin resides.
- (2) The  $nCEO$  pin is left unconnected or used as a user I/O pin when it does not feed the  $nCE$  pin of another device.
- (3) The  $MSEL$  pin settings vary for different configuration voltage standards and POR time. To connect  $MSEL[3..0]$ , refer to [Table 8-5 on page 8-9](#). Connect the  $MSEL$  pins directly to  $V_{CCA}$  or GND.
- (4) AP configuration ignores the  $WAIT$  signal during configuration mode. However, if you are accessing flash during user mode with user logic, you can optionally use normal I/O to monitor the  $WAIT$  signal from the Micron P30 or P33 flash.

-  To tri-state the configuration bus for AP configuration schemes, you must tie  $nCE$  high and  $nCONFIG$  low.
-  In a single-device AP configuration, the maximum board loading and board trace length between supported parallel flash and Cyclone IV E devices must follow the recommendations listed in [Table 8-11 on page 8-28](#).
-  If you use the AP configuration scheme for Cyclone IV E devices, the  $V_{CCIO}$  of I/O banks 1, 6, 7, and 8 must be 3.3, 3.0, 2.5, or 1.8 V. Altera does not recommend using the level shifter between the Micron P30 or P33 flash and the Cyclone IV E device in the AP configuration scheme.

 There are no series resistors required in AP configuration mode for Cyclone IV E devices when using the Micron flash at 2.5-, 3.0-, and 3.3-V I/O standard. The output buffer of the Micron P30 IBIS model does not overshoot above 4.1 V. Thus, series resistors are not required for the 2.5-, 3.0-, and 3.3-V AP configuration option. However, if there are any other devices sharing the same flash I/Os with Cyclone IV E devices, all shared pins are still subject to the 4.1-V limit and may require series resistors.

Default read mode of the supported parallel flash memory and all writes to the parallel flash memory are asynchronous. Both the parallel flash families support a synchronous read mode, with data supplied on the positive edge of DCLK.

The serial clock (DCLK) generated by Cyclone IV E devices controls the entire configuration cycle and provides timing for the parallel interface.

### Multi-Device AP Configuration

You can configure multiple Cyclone IV E devices using a single parallel flash. You can cascade multiple Cyclone IV E devices using the chip-enable (nCE) and chip-enable-out (nCEO) pins. The first device in the chain must have its nCE pin connected to GND. You must connect its nCEO pin to the nCE pin of the next device in the chain. Use an external 10-k $\Omega$  pull-up resistor to pull the nCEO signal high to its V<sub>CCIO</sub> level to help the internal weak pull-up resistor. When the first device captures all its configuration data from the bitstream, it drives the nCEO pin low, enabling the next device in the chain. You can leave the nCEO pin of the last device unconnected or use it as a user I/O pin after configuration if the last device in the chain is a Cyclone IV E device. The nCONFIG, nSTATUS, CONF\_DONE, DCLK, DATA [15..8], and DATA [7..0] pins of each device in the chain are connected ([Figure 8-8 on page 8-26](#) and [Figure 8-9 on page 8-27](#)).

The first Cyclone IV E device in the chain, as shown in [Figure 8-8 on page 8-26](#) and [Figure 8-9 on page 8-27](#), is the configuration master device and controls the configuration of the entire chain. You must connect its MSEL pins to select the AP configuration scheme. The remaining Cyclone IV E devices are used as configuration slaves. You must connect their MSEL pins to select the FPP configuration scheme. Any other Altera device that supports FPP configuration can also be part of the chain as a configuration slave.

The following are the configurations for the DATA [15..0] bus in a multi-device AP configuration:

- Byte-wide multi-device AP configuration
- Word-wide multi-device AP configuration

## Byte-Wide Multi-Device AP Configuration

The simpler method for multi-device AP configuration is the byte-wide multi-device AP configuration. In the byte-wide multi-device AP configuration, the LSB of the DATA [7..0] pin from the flash and master device (set to the AP configuration scheme) is connected to the slave devices set to the FPP configuration scheme, as shown in Figure 8-8.

**Figure 8-8. Byte-Wide Multi-Device AP Configuration**

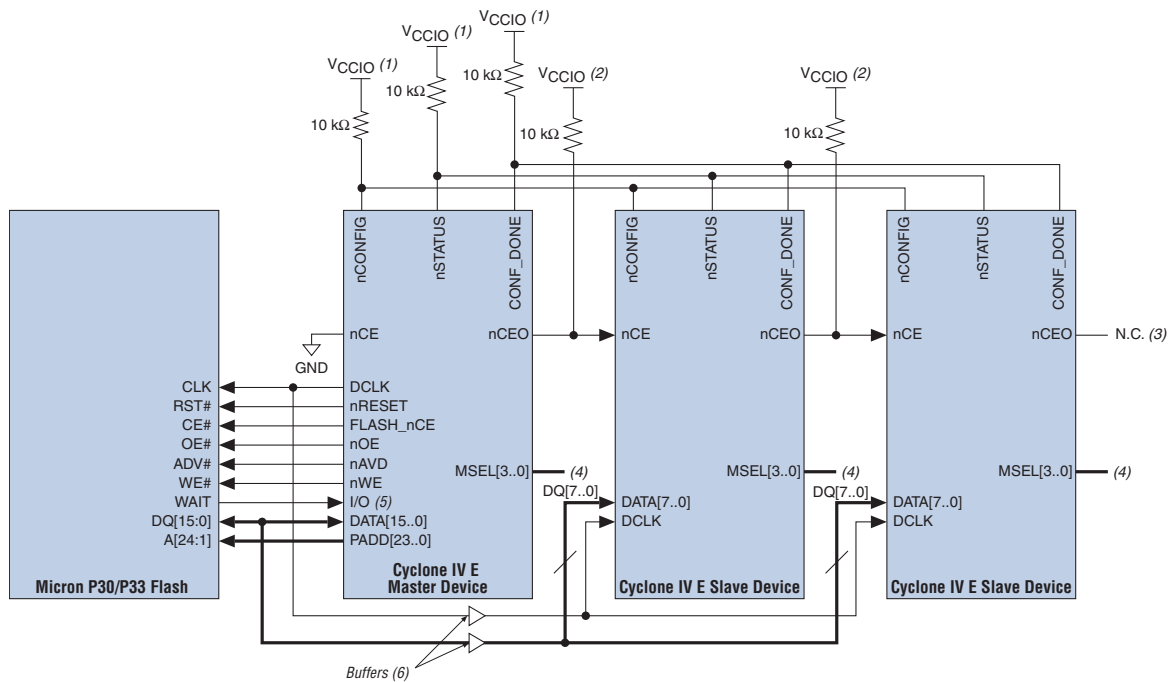

### Notes to Figure 8-8:

- (1) Connect the pull-up resistors to the  $V_{CCIO}$  supply of the bank in which the pin resides.
- (2) Connect the pull-up resistor to the  $V_{CCIO}$  supply voltage of the I/O bank in which the  $nCE$  pin resides.
- (3) The  $nCEO$  pin is left unconnected or used as a user I/O pin when it does not feed the  $nCE$  pin of another device.
- (4) The  $MSEL$  pin settings vary for different configuration voltage standards and POR time. You must set the master device in AP mode and the slave devices in FPP mode. To connect  $MSEL[3..0]$  for the master device in AP mode and the slave devices in FPP mode, refer to [Table 8-5 on page 8-9](#). Connect the  $MSEL$  pins directly to  $V_{CCA}$  or GND.
- (5) The AP configuration ignores the  $WAIT$  signal during configuration mode. However, if you are accessing flash during user mode with user logic, you can optionally use the normal I/O to monitor the  $WAIT$  signal from the Micron P30 or P33 flash.
- (6) Connect the repeater buffers between the Cyclone IV E master device and slave devices for  $DATA[15..0]$  and  $DCLK$ . All I/O inputs must maintain a maximum AC voltage of 4.1 V. The output resistance of the repeater buffers must fit the maximum overshoot equation outlined in “[Configuration and JTAG Pin I/O Requirements](#)” on page 8-5.

## Word-Wide Multi-Device AP Configuration

The more efficient setup is one in which some of the slave devices are connected to the LSB of the DATA [7..0] and the remaining slave devices are connected to the MSB of the DATA [15..8]. In the word-wide multi-device AP configuration, the  $nCEO$  pin of the master device enables two separate daisy chains of slave devices, allowing both chains to be programmed concurrently, as shown in Figure 8-9.

Figure 8-9. Word-Wide Multi-Device AP Configuration

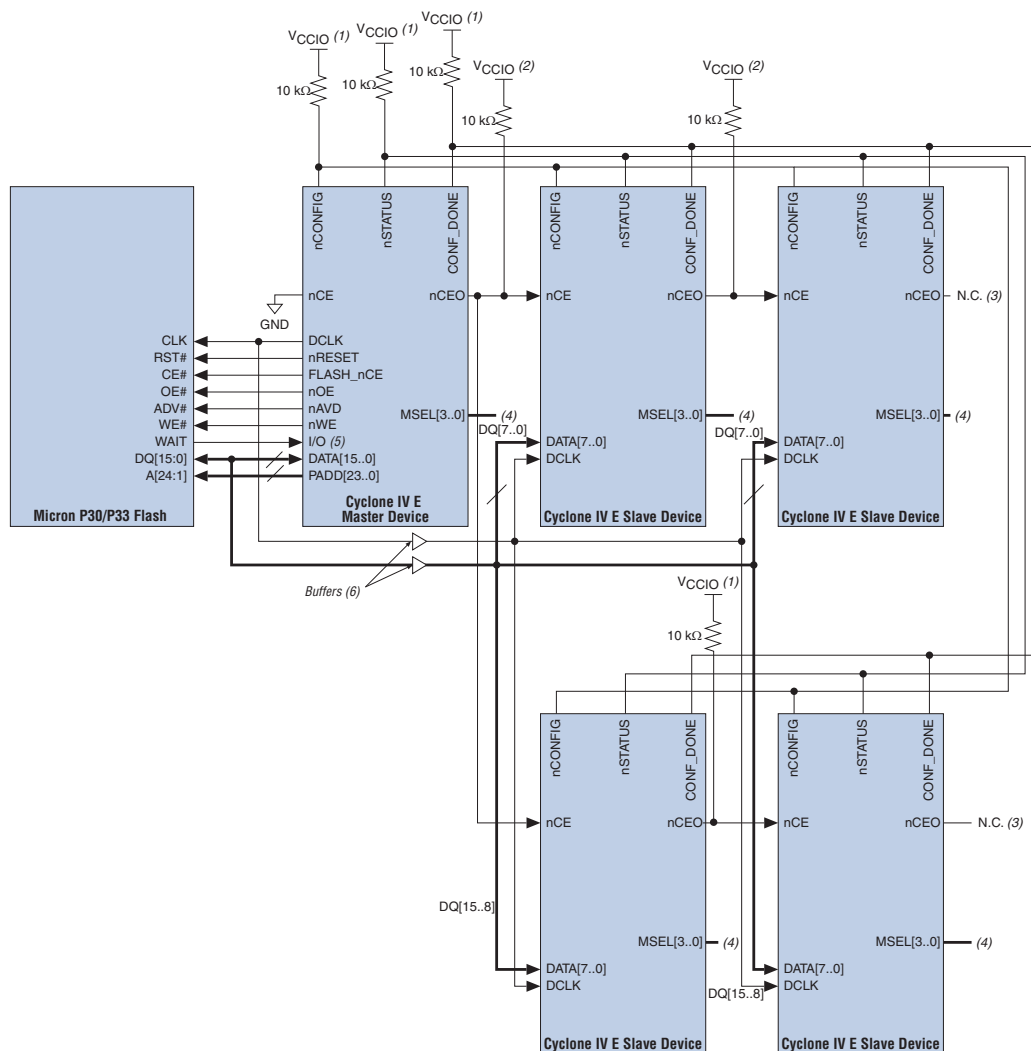

**Notes to Figure 8-9:**

- (1) Connect the pull-up resistors to the  $V_{CCIO}$  supply of the bank in which the pin resides.
- (2) Connect the pull-up resistor to the  $V_{CCIO}$  supply voltage of the I/O bank in which the nCE pin resides.
- (3) The nCEO pin is left unconnected or used as a user I/O pin when it does not feed the nCE pin of another device.
- (4) The MSEL pin settings vary for different configuration voltage standards and POR time. You must set the master device in AP mode and the slave devices in FPP mode. To connect MSEL[3..0] for the master device in AP mode and the slave devices in FPP mode, refer to [Table 8-5 on page 8-9](#). Connect the MSEL pins directly to  $V_{CCA}$  or GND.
- (5) The AP configuration ignores the WAIT signal during configuration mode. However, if you are accessing flash during user mode with user logic, you can optionally use the normal I/O pin to monitor the WAIT signal from the Micron P30 or P33 flash.
- (6) Connect the repeater buffers between the Cyclone IV E master device and slave devices for DATA[15..0] and DCLK. All I/O inputs must maintain a maximum AC voltage of 4.1 V. The output resistance of the repeater buffers must fit the maximum overshoot equation outlined in “[Configuration and JTAG Pin I/O Requirements](#)” on page 8-5.



In a multi-device AP configuration, the board trace length between the parallel flash and the master device must follow the recommendations listed in [Table 8-11](#).

The `nSTATUS` and `CONF_DONE` pins on all target devices are connected together with external pull-up resistors, as shown in [Figure 8-8 on page 8-26](#) and [Figure 8-9 on page 8-27](#). These pins are open-drain bidirectional pins on the devices. When the first device asserts `nCEO` (after receiving all its configuration data), it releases its `CONF_DONE` pin. However, the subsequent devices in the chain keep this shared `CONF_DONE` line low until they receive their configuration data. When all target devices in the chain receive their configuration data and release `CONF_DONE`, the pull-up resistor drives a high level on this line and all devices simultaneously enter initialization mode.

### Guidelines for Connecting Parallel Flash to Cyclone IV E Devices for an AP Interface

For single- and multi-device AP configuration, the board trace length and loading between the supported parallel flash and Cyclone IV E devices must follow the recommendations listed in [Table 8-11](#). These recommendations also apply to an AP configuration with multiple bus masters.

**Table 8-11. Maximum Trace Length and Loading for AP Configuration**

Cyclone IV E AP Pins	Maximum Board Trace Length from Cyclone IV E Device to Flash Device (inches)	Maximum Board Load (pF)
DCLK	6	15
DATA [15..0]	6	30
PADD [23..0]	6	30
nRESET	6	30
Flash_nCE	6	30
nOE	6	30
nAVD	6	30
nWE	6	30
I/O <sup>(1)</sup>	6	30

**Note to Table 8-11:**

- (1) The AP configuration ignores the `WAIT` signal from the flash during configuration mode. However, if you are accessing flash during user mode with user logic, you can optionally use the normal I/O to monitor the `WAIT` signal from the Micron P30 or P33 flash.

### Configuring With Multiple Bus Masters

Similar to the AS configuration scheme, the AP configuration scheme supports multiple bus masters for the parallel flash. For another master to take control of the AP configuration bus, the master must assert `nCONFIG` low for at least 500 ns to reset the master Cyclone IV E device and override the weak 10-k $\Omega$  pull-down resistor on the `nCE` pin. This resets the master Cyclone IV E device and causes it to tri-state its AP configuration bus. The other master device then takes control of the AP configuration bus. After the other master device is done, it releases the AP configuration bus, then releases the `nCE` pin, and finally pulses `nCONFIG` low to restart the configuration.

In the AP configuration scheme, multiple masters share the parallel flash. Similar to the AS configuration scheme, the bus control is negotiated by the `nCE` pin.

Figure 8-10 shows the AP configuration with multiple bus masters.

Figure 8-10. AP Configuration with Multiple Bus Masters

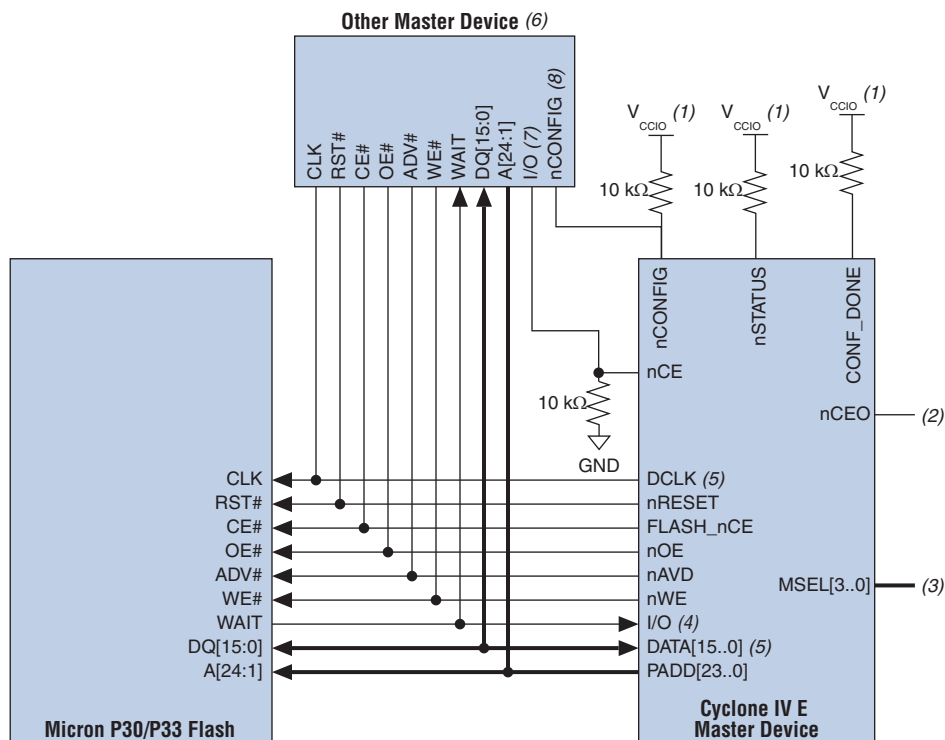

Notes to Figure 8-10:

- (1) Connect the pull-up resistors to the V<sub>CCIO</sub> supply of the bank in which the pin resides.
- (2) The nCEO pin is left unconnected or used as a user I/O pin when it does not feed the nCE pin of another device.
- (3) The MSEL pin settings vary for different configuration voltage standards and POR time. To connect MSEL[3..0], refer to Table 8-5 on page 8-9. Connect the MSEL pins directly to V<sub>CCA</sub> or GND.
- (4) The AP configuration ignores the WAIT signal during configuration mode. However, if you are accessing flash during user mode with user logic, you can optionally use the normal I/O to monitor the WAIT signal from the Micron P30 or P33 flash.
- (5) When cascading Cyclone IV E devices in a multi-device AP configuration, connect the repeater buffers between the master device and slave devices for DATA[15..0] and DCLK. All I/O inputs must maintain a maximum AC voltage of 4.1 V. The output resistance of the repeater buffers must fit the maximum overshoot equation outlined in "Configuration and JTAG Pin I/O Requirements" on page 8-5.
- (6) The other master device must fit the maximum overshoot equation outlined in "Configuration and JTAG Pin I/O Requirements" on page 8-5.
- (7) The other master device can control the AP configuration bus by driving the nCE to high with an output high on the I/O pin.
- (8) The other master device can pulse nCONFIG if it is under system control and not tied to V<sub>CCIO</sub>.

Figure 8-11 shows the recommended balanced star routing for multiple bus master interfaces to minimize signal integrity issues.

**Figure 8-11. Balanced Star Routing**

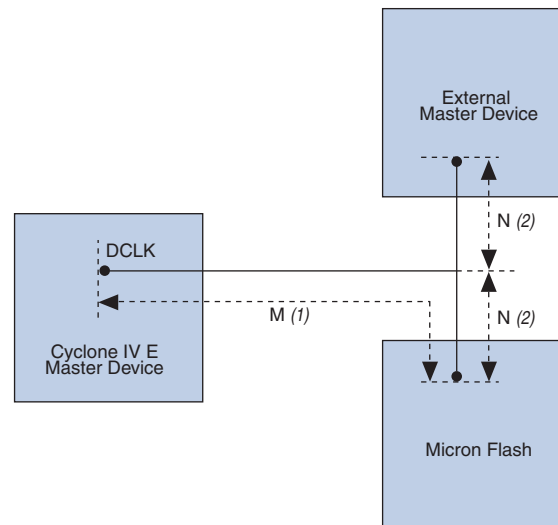

**Notes to Figure 8-11:**

- (1) Altera recommends that  $M$  does not exceed 6 inches, as listed in Table 8-11 on page 8-28.
- (2) Altera recommends using a balanced star routing. Keep the  $N$  length equal and as short as possible to minimize reflection noise from the transmission line. The  $M$  length is applicable for this setup.

### Estimating AP Configuration Time

AP configuration time is dominated by the time it takes to transfer data from the parallel flash to Cyclone IV E devices. This parallel interface is clocked by the Cyclone IV E DCLK output (generated from an internal oscillator). The DCLK minimum frequency when using the 40-MHz oscillator is 20 MHz (50 ns). In word-wide cascade programming, the DATA [15..0] bus transfers a 16-bit word and essentially cuts configuration time to approximately 1/16 of the AS configuration time. Equation 8-4 and Equation 8-5 show the configuration time calculations.

**Equation 8-4.**

$$\text{Size} \times \left( \frac{\text{maximum DCLK period}}{16 \text{ bits per DCLK cycle}} \right) = \text{estimated maximum configuration time}$$

**Equation 8-5.**

$$9,600,000 \text{ bits} \times \left( \frac{50 \text{ ns}}{16 \text{ bit}} \right) = 30 \text{ ms}$$

## Programming Parallel Flash Memories

Supported parallel flash memories are external non-volatile configuration devices. They are industry standard microprocessor flash memories. For more information about the supported families for the commodity parallel flash, refer to [Table 8-10 on page 8-22](#).

Cyclone IV E devices in a single- or multiple-device chain support in-system programming of a parallel flash using the JTAG interface with the flash loader megafunction. The board intelligent host or download cable uses the four JTAG pins on Cyclone IV E devices to program the parallel flash in system, even if the host or download cable cannot access the configuration pins of the parallel flash.

-  For more information about using the JTAG pins on Cyclone IV E devices to program the parallel flash in-system, refer to [AN 478: Using FPGA-Based Parallel Flash Loader \(PFL\) with the Quartus II Software](#).

In the AP configuration scheme, the default configuration boot address is  $0 \times 010000$  when represented in 16-bit word addressing in the supported parallel flash memory ([Figure 8-12](#)). In the Quartus II software, the default configuration boot address is  $0 \times 020000$  because it is represented in 8-bit byte addressing. Cyclone IV E devices configure from word address  $0 \times 010000$ , which is equivalent to byte address  $0 \times 020000$ .

-  The Quartus II software uses byte addressing for the default configuration boot address. You must set the start address field to  **$0 \times 020000$** .

The default configuration boot address allows the system to use special parameter blocks in the flash memory map. Parameter blocks are at the top or bottom of the memory map. Figure 8–12 shows the configuration boot address in the AP configuration scheme. You can change the default configuration default boot address 0x010000 to any desired address using the APFC\_BOOT\_ADDR JTAG instruction. For more information about the APFC\_BOOT\_ADDR JTAG instruction, refer to “JTAG Instructions” on page 8–57.

**Figure 8–12. Configuration Boot Address in AP Flash Memory Map**

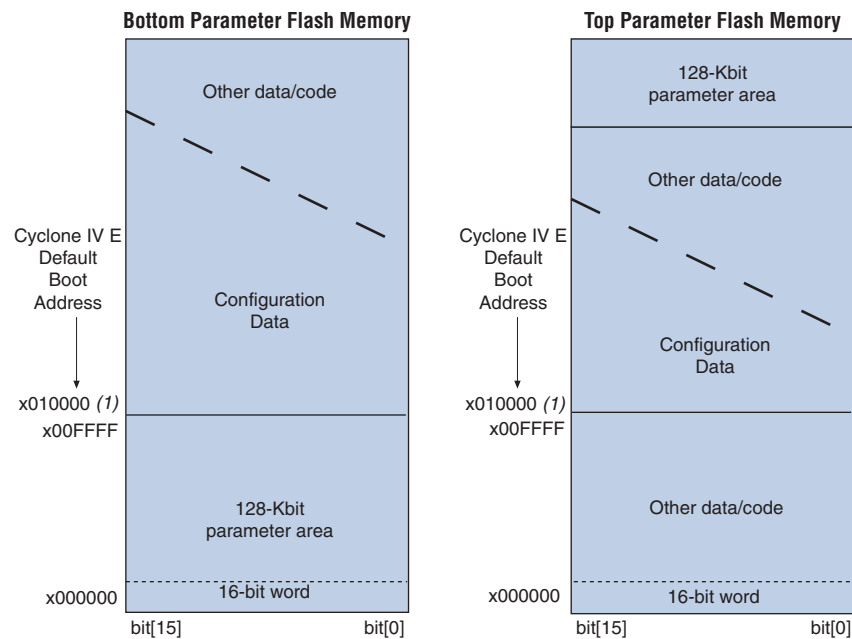

**Note to Figure 8–12:**

(1) The default configuration boot address is x010000 when represented in 16-bit word addressing.

## PS Configuration

You can perform PS configuration on Cyclone IV devices with an external intelligent host, such as a MAX<sup>®</sup> II device, microprocessor with flash memory, or a download cable. In the PS scheme, an external host controls the configuration. Configuration data is clocked into the target Cyclone IV device through DATA[0] at each rising edge of DCLK.

If your system already contains a common flash interface (CFI) flash memory, you can use it for Cyclone IV device configuration storage as well. The MAX II PFL feature provides an efficient method to program CFI flash memory devices through the JTAG interface and the logic to control the configuration from the flash memory device to the Cyclone IV device.



For more information about the PFL, refer to *AN 386: Using the Parallel Flash Loader with the Quartus II Software*.



Cyclone IV devices do not support enhanced configuration devices for PS configuration.

## PS Configuration Using an External Host

In the PS configuration scheme, you can use an intelligent host such as a MAX II device or microprocessor that controls the transfer of configuration data from a storage device, such as flash memory, to the target Cyclone IV device. You can store the configuration data in **.rbf**, **.hex**, or **.tff** format.

Figure 8-13 shows the configuration interface connections between a Cyclone IV device and an external host device for single-device configuration.

**Figure 8-13. Single-Device PS Configuration Using an External Host**

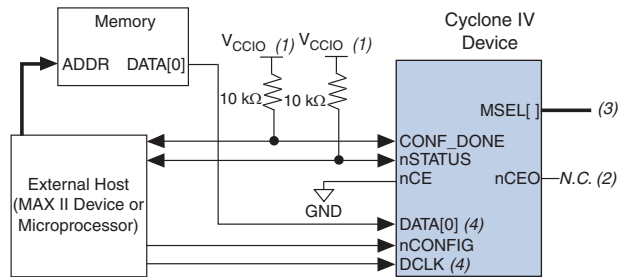

### Notes to Figure 8-13:

- (1) Connect the pull-up resistor to a supply that provides an acceptable input signal for the device.  $V_{CC}$  must be high enough to meet the  $V_{IH}$  specification of the I/O on the device and the external host.
- (2) The  $n_{CEO}$  pin is left unconnected or used as a user I/O pin when it does not feed the  $n_{CE}$  pin of another device.
- (3) The  $MSEL$  pin settings vary for different configuration voltage standards and POR time. To connect the  $MSEL$  pins, refer to Table 8-3 on page 8-8, Table 8-4 on page 8-8, and Table 8-5 on page 8-9. Connect the  $MSEL$  pins directly to  $V_{CCA}$  or GND.
- (4) All I/O inputs must maintain a maximum AC voltage of 4.1 V.  $DATA[0]$  and  $DCLK$  must fit the maximum overshoot outlined in Equation 8-1 on page 8-5.

To begin the configuration, the external host device must generate a low-to-high transition on the  $n_{CONFIG}$  pin. When  $n_{STATUS}$  is pulled high, the external host device must place the configuration data one bit at a time on  $DATA[0]$ . If you use configuration data in **.rbf**, **.tff**, or **.hex**, you must first send the LSB of each data byte. For example, if the **.rbf** contains the byte sequence 02 1B EE 01 FA, the serial bitstream you must send to the device is:

```
0100-0000 1101-1000 0111-0111 1000-0000 0101-1111
```

Cyclone IV devices receive configuration data on  $DATA[0]$  and the clock is received on  $DCLK$ . Data is latched into the device on the rising edge of  $DCLK$ . Data is continuously clocked into the target device until  $CONF\_DONE$  goes high and the device enters initialization state.



Two  $DCLK$  falling edges are required after  $CONF\_DONE$  goes high to begin the initialization of the device.

$INIT\_DONE$  is released and pulled high when initialization is complete. The external host device must be able to detect this low-to-high transition which signals the device has entered user mode. When initialization is complete, the device enters user mode. In user mode, the user I/O pins no longer have weak pull-up resistors and function as assigned in your design.

To ensure DCLK and DATA [0] are not left floating at the end of configuration, the MAX II device must drive them either high or low, whichever is convenient on your board. The DATA [0] pin is available as a user I/O pin after configuration. In the PS scheme, the DATA [0] pin is tri-stated by default in user mode and must be driven by the external host device. To change this default option in the Quartus II software, select the **Dual-Purpose Pins** tab of the **Device and Pin Options** dialog box.

The configuration clock (DCLK) speed must be below the specified system frequency to ensure correct configuration. No maximum DCLK period exists, which means you can pause configuration by halting DCLK for an indefinite amount of time.

The external host device can also monitor CONF\_DONE and INIT\_DONE to ensure successful configuration. The CONF\_DONE pin must be monitored by the external device to detect errors and to determine when programming is complete. If all configuration data is sent, but CONF\_DONE or INIT\_DONE has not gone high, the external device must reconfigure the target device.

Figure 8-14 shows how to configure multiple devices using an external host device. This circuit is similar to the PS configuration circuit for a single device, except that Cyclone IV devices are cascaded for multi-device configuration.

**Figure 8-14. Multi-Device PS Configuration Using an External Host**

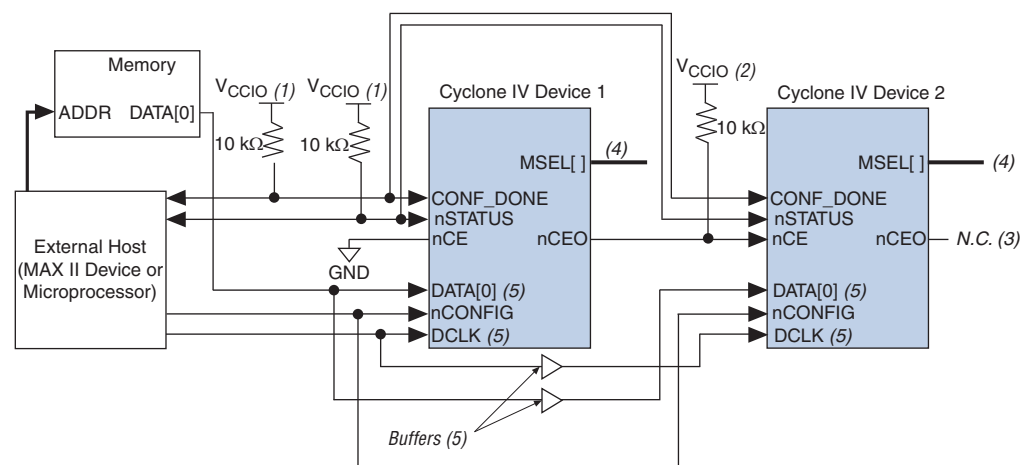

**Notes to Figure 8-14:**

- (1) The pull-up resistor must be connected to a supply that provides an acceptable input signal for all devices in the chain.  $V_{CC}$  must be high enough to meet the  $V_{IH}$  specification of the I/O on the device and the external host.
- (2) Connect the pull-up resistor to the  $V_{CCIO}$  supply voltage of the I/O bank in which the nCE pin resides.
- (3) The nCEO pin is left unconnected or used as a user I/O pin when it does not feed the nCE pin of another device.
- (4) The MSEL pin settings vary for different configuration voltage standards and POR time. To connect the MSEL pins, refer to Table 8-3 on page 8-8, Table 8-4 on page 8-8, and Table 8-5 on page 8-9. Connect the MSEL pins directly to  $V_{CCA}$  or GND.
- (5) All I/O inputs must maintain a maximum AC voltage of 4.1 V. DATA [0] and DCLK must fit the maximum overshoot outlined in Equation 8-1 on page 8-5.

After the first device completes configuration in a multi-device configuration chain, its  $nCE$  pin drives low to activate the  $nCE$  pin of the second device, which prompts the second device to begin configuration. The second device in the chain begins configuration in one clock cycle. Therefore, the transfer of data destinations is transparent to the external host device.  $nCONFIG$ ,  $nSTATUS$ ,  $DCLK$ ,  $DATA[0]$ , and  $CONF\_DONE$  configuration pins are connected to every device in the chain. To ensure signal integrity and prevent clock skew problems, configuration signals may require buffering. Ensure that  $DCLK$  and  $DATA$  lines are buffered. All devices initialize and enter user mode at the same time because all  $CONF\_DONE$  pins are tied together.

If any device detects an error, configuration stops for the entire chain and you must reconfigure the entire chain because all  $nSTATUS$  and  $CONF\_DONE$  pins are tied together. For example, if the first device flags an error on  $nSTATUS$ , it resets the chain by pulling its  $nSTATUS$  pin low. This behavior is similar to a single device detecting an error.

You can have multiple devices that contain the same configuration data in your system. To support this configuration scheme, all device  $nCE$  inputs are tied to GND, while the  $nCEO$  pins are left floating.  $nCONFIG$ ,  $nSTATUS$ ,  $DCLK$ ,  $DATA[0]$ , and  $CONF\_DONE$  configuration pins are connected to every device in the chain. To ensure signal integrity and prevent clock skew problems, configuration signals may require buffering. Ensure that the  $DCLK$  and  $DATA$  lines are buffered. Devices must be of the same density and package. All devices start and complete configuration at the same time.

Figure 8-15 shows a multi-device PS configuration when both Cyclone IV devices are receiving the same configuration data.

**Figure 8-15. Multi-Device PS Configuration When Both Devices Receive the Same Data**

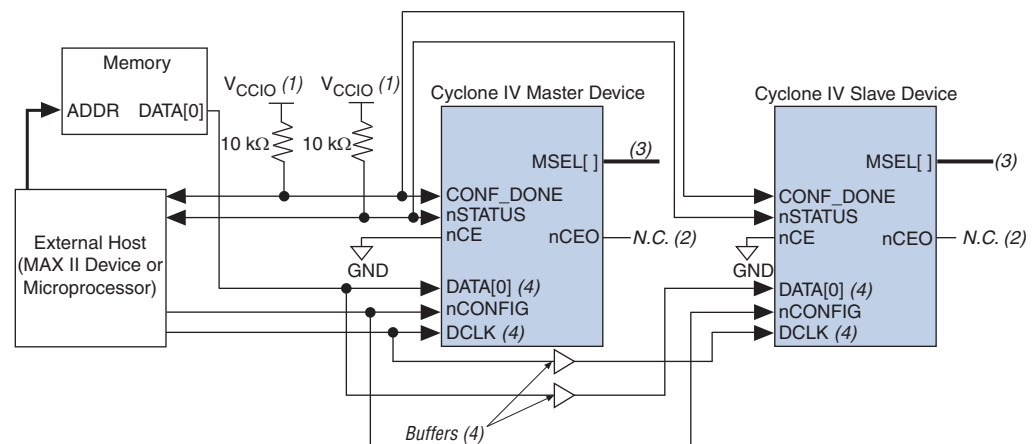

**Notes to Figure 8-15:**

- (1) You must connect the pull-up resistor to a supply that provides an acceptable input signal for all devices in the chain.  $V_{CC}$  must be high enough to meet the  $V_{IH}$  specification of the I/O on the device and the external host.
- (2) The  $nCEO$  pins of both devices are left unconnected or used as user I/O pins when configuring the same configuration data into multiple devices.
- (3) The  $MSEL$  pin settings vary for different configuration voltage standards and POR time. To connect the  $MSEL$  pins, refer to Table 8-3 on page 8-8, Table 8-4 on page 8-8, and Table 8-5 on page 8-9. Connect the  $MSEL$  pins directly to  $V_{CCA}$  or GND.
- (4) All I/O inputs must maintain a maximum AC voltage of 4.1 V.  $DATA[0]$  and  $DCLK$  must fit the maximum overshoot outlined in Equation 8-1 on page 8-5.

## PS Configuration Timing

A PS configuration must meet the setup and hold timing parameters and the maximum clock frequency. When using a microprocessor or another intelligent host to control the PS interface, ensure that you meet these timing requirements.

Figure 8-16 shows the timing waveform for PS configuration when using an external host device.

**Figure 8-16. PS Configuration Timing Waveform (1)**

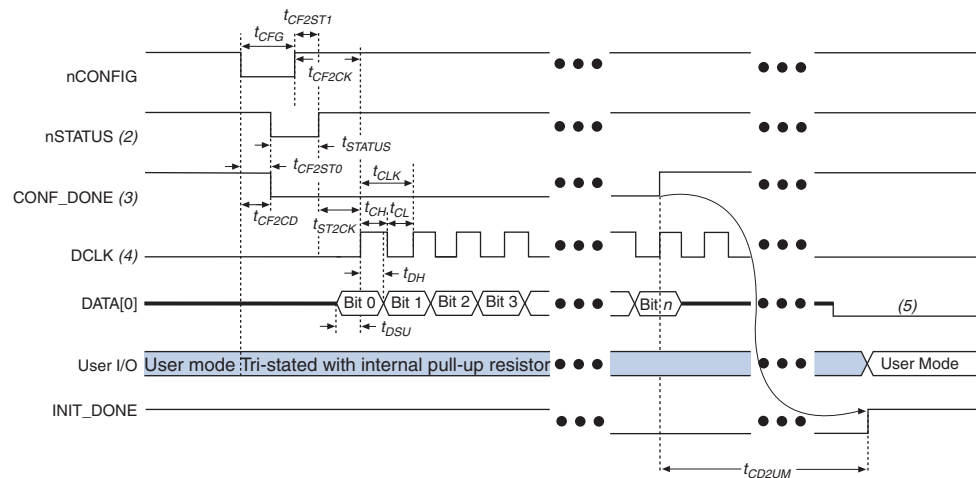

### Notes to Figure 8-16:

- (1) The beginning of this waveform shows the device in user mode. In user mode, nCONFIG, nSTATUS, and CONF\_DONE are at logic-high levels. When nCONFIG is pulled low, a reconfiguration cycle begins.
- (2) After power up, the Cyclone IV device holds nSTATUS low during POR delay.
- (3) After power up, before and during configuration, CONF\_DONE is low.
- (4) In user mode, drive DCLK either high or low when using the PS configuration scheme, whichever is more convenient. When using the AS configuration scheme, DCLK is a Cyclone IV device output pin and must not be driven externally.
- (5) Do not leave the DATA [0] pin floating after configuration. Drive the DATA [0] pin high or low, whichever is more convenient.

Table 8-12 lists the PS configuration timing parameters for Cyclone IV devices.

**Table 8-12. PS Configuration Timing Parameters For Cyclone IV Devices (Part 1 of 2)**

Symbol	Parameter	Minimum		Maximum		Unit
		Cyclone IV (1)	Cyclone IV E (2)	Cyclone IV (1)	Cyclone IV E (2)	
t <sub>CF2CD</sub>	nCONFIG low to CONF_DONE low	—	—	500	—	ns
t <sub>CF2ST0</sub>	nCONFIG low to nSTATUS low	—	—	500	—	ns
t <sub>CFG</sub>	nCONFIG low pulse width	500	—	—	—	ns
t <sub>STATUS</sub>	nSTATUS low pulse width	45	—	230 (3)	—	μs

**Table 8-12. PS Configuration Timing Parameters For Cyclone IV Devices (Part 2 of 2)**

Symbol	Parameter	Minimum		Maximum		Unit
		Cyclone IV <sup>(1)</sup>	Cyclone IV E <sup>(2)</sup>	Cyclone IV <sup>(1)</sup>	Cyclone IV E <sup>(2)</sup>	
$t_{CF2ST1}$	nCONFIG high to nSTATUS high	—		230 <sup>(4)</sup>		μs
$t_{CF2CK}$	nCONFIG high to first rising edge on DCLK	230 <sup>(3)</sup>		—		μs
$t_{ST2CK}$	nSTATUS high to first rising edge of DCLK	2		—		μs
$t_{DH}$	Data hold time after rising edge on DCLK	0		—		ns
$t_{CD2UM}$	CONF_DONE high to user mode <sup>(5)</sup>	300		650		μs
$t_{CD2CU}$	CONF_DONE high to CLKUSR enabled	4 × maximum DCLK period		—		—
$t_{CD2UMC}$	CONF_DONE high to user mode with <b>CLKUSR</b> option on	$t_{CD2CU} + (3,192 \times \text{CLKUSR period})$		—		—
$t_{DSU}$	Data setup time before rising edge on DCLK	5	8	—	—	ns
$t_{CH}$	DCLK high time	3.2	6.4	—	—	ns
$t_{CL}$	DCLK low time	3.2	6.4	—	—	ns
$t_{CLK}$	DCLK period	7.5	15	—	—	ns
$f_{MAX}$	DCLK frequency <sup>(6)</sup>	—	—	133	66	MHz

**Notes to Table 8-12:**

- (1) Applicable for Cyclone IV GX and Cyclone IV E devices with 1.2-V core voltage.
- (2) Applicable for Cyclone IV E devices with 1.0-V core voltage.
- (3) This value is applicable if you do not delay configuration by extending the nCONFIG or nSTATUS low pulse width.
- (4) This value is applicable if you do not delay configuration by externally holding the nSTATUS low.
- (5) The minimum and maximum numbers apply only if you choose the internal oscillator as the clock source for starting the device.
- (6) Cyclone IV E devices with 1.0-V core voltage have slower  $F_{MAX}$  when compared with Cyclone IV GX devices with 1.2-V core voltage.

### PS Configuration Using a Download Cable

In this section, the generic term “download cable” includes the Altera USB-Blaster USB port download cable, MasterBlaster™ serial and USB communications cable, ByteBlaster II parallel port download cable, the ByteBlasterMV™ parallel port download cable, and the EthernetBlaster communications cable.

In the PS configuration with a download cable, an intelligent host (such as a PC) transfers data from a storage device to the Cyclone IV device through the download cable.

The programming hardware or download cable then places the configuration data one bit at a time on the DATA[0] pin of the device. The configuration data is clocked into the target device until CONF\_DONE goes high. The CONF\_DONE pin must have an external 10-k $\Omega$  pull-up resistor for the device to initialize.

When you use a download cable, setting the **Auto-restart configuration after error** option does not affect the configuration cycle because you must manually restart configuration in the Quartus II software if an error occurs. Additionally, the **Enable user-supplied start-up clock (CLKUSR)** option has no effect on device initialization, because this option is disabled in the .sof when programming the device with the Quartus II Programmer and download cable. Therefore, if you turn on the CLKUSR option, you do not have to provide a clock on CLKUSR when you configure the device with the Quartus II Programmer and a download cable.

Figure 8-17 shows PS configuration for Cyclone IV devices with a download cable.

**Figure 8-17. PS Configuration Using a Download Cable**

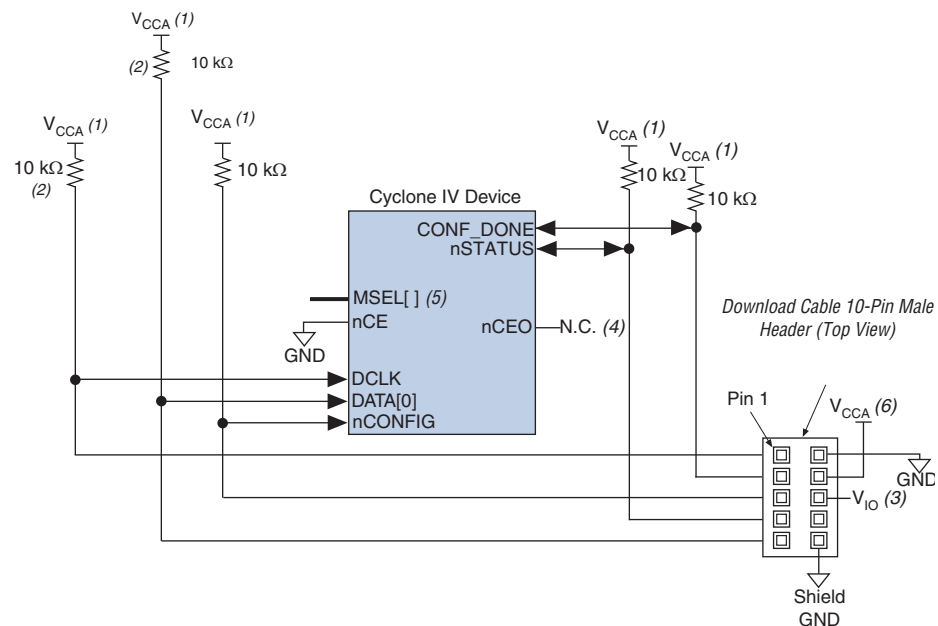

**Notes to Figure 8-17:**

- (1) You must connect the pull-up resistor to the same supply voltage as the  $V_{CCA}$  supply.
- (2) The pull-up resistors on DATA[0] and DCLK are only required if the download cable is the only configuration scheme used on your board. This is to ensure that DATA[0] and DCLK are not left floating after configuration. For example, if you also use a configuration device, the pull-up resistors on DATA[0] and DCLK are not required.
- (3) Pin 6 of the header is a  $V_{IO}$  reference voltage for the MasterBlaster output driver.  $V_{IO}$  must match the  $V_{CCA}$  of the device. For this value, refer to the *MasterBlaster Serial/USB Communications Cable User Guide*. With the USB-Blaster, ByteBlaster II, ByteBlaster MV, and EthernetBlaster, this pin is a no connect.
- (4) The nCEO pin is left unconnected or used as a user I/O pin when it does not feed the nCE pin of another device.
- (5) The MSEL pin settings vary for different configuration voltage standards and POR time. To connect the MSEL pins, refer to Table 8-3 on page 8-8, Table 8-4 on page 8-8, and Table 8-5 on page 8-9 for PS configuration schemes. Connect the MSEL pins directly to  $V_{CCA}$  or GND.
- (6) Power up the  $V_{CC}$  of the ByteBlaster II, USB-Blaster, or ByteBlasterMV cable with a 2.5-V supply from  $V_{CCA}$ . Third-party programmers must switch to 2.5 V. Pin 4 of the header is a  $V_{CC}$  power supply for the MasterBlaster cable. The MasterBlaster cable can receive power from either 5.0- or 3.3-V circuit boards, DC power supply, or 5.0 V from the USB cable. For this value, refer to the *MasterBlaster Serial/USB Communications Cable User Guide*.

You can use a download cable to configure multiple Cyclone IV device configuration pins. `nCONFIG`, `nSTATUS`, `DCLK`, `DATA[0]`, and `CONF_DONE` are connected to every device in the chain. All devices in the chain utilize and enter user mode at the same time because all `CONF_DONE` pins are tied together.

In addition, the entire chain halts configuration if any device detects an error because the `nSTATUS` pins are tied together. Figure 8-18 shows the PS configuration for multiple Cyclone IV devices using a MasterBlaster, USB-Blaster, ByteBlaster II, or ByteBlasterMV cable.

**Figure 8-18. Multi-Device PS Configuration Using a Download Cable**

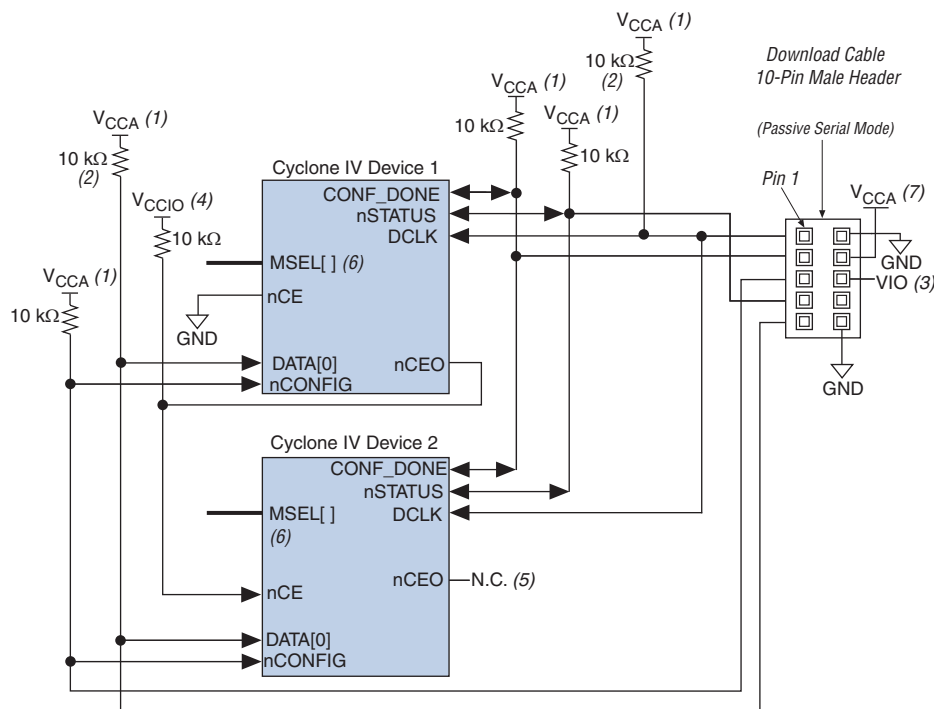





**Notes to Figure 8-18:**

- (1) You must connect the pull-up resistor to the same supply voltage as the  $V_{CCA}$  supply.
- (2) The pull-up resistors on `DATA[0]` and `DCLK` are only required if the download cable is the only configuration scheme used on your board. This ensures that `DATA[0]` and `DCLK` are not left floating after configuration. For example, if you also use a configuration device, the pull-up resistors on `DATA[0]` and `DCLK` are not required.
- (3) Pin 6 of the header is a  $V_{IO}$  reference voltage for the MasterBlaster output driver.  $V_{IO}$  must match the  $V_{CCA}$  of the device. For this value, refer to the *MasterBlaster Serial/USB Communications Cable User Guide*. When using the ByteBlasterMV download cable, this pin is a no connect. When using USB-Blaster, ByteBlaster II, and EthernetBlaster cables, this pin is connected to `nCE` when it is used for AS programming. Otherwise, it is a no connect.
- (4) Connect the pull-up resistor to the  $V_{CCIO}$  supply voltage of the I/O bank in which the `nCE` resides.
- (5) The `nCEO` pin of the last device in the chain is left unconnected or used as a user I/O pin.
- (6) The `MSEL` pin settings vary for different configuration voltage standards and POR time. To connect `MSEL` for PS configuration schemes, refer to Table 8-3 on page 8-8, Table 8-4 on page 8-8, and Table 8-5 on page 8-9. Connect the `MSEL` pins directly to  $V_{CCA}$  or GND.
- (7) Power up the  $V_{CC}$  of the ByteBlaster II, USB-Blaster, or ByteBlasterMV cable with a 2.5 V supply from  $V_{CCA}$ . Third-party programmers must switch to 2.5 V. Pin 4 of the header is a  $V_{CC}$  power supply for the MasterBlaster cable. The MasterBlaster cable can receive power from either 5.0- or 3.3-V circuit boards, DC power supply, or 5.0 V from the USB cable. For this value, refer to the *MasterBlaster Serial/USB Communications Cable User Guide*.

## FPP Configuration

The FPP configuration in Cyclone IV devices is designed to meet the increasing demand for faster configuration time. Cyclone IV devices are designed with the capability of receiving byte-wide configuration data per clock cycle.

You can perform FPP configuration of Cyclone IV devices with an intelligent host, such as a MAX II device or microprocessor with flash memory. If your system already contains a CFI flash memory, you can use it for the Cyclone IV device configuration storage as well. The MAX II PFL feature in MAX II devices provides an efficient method to program CFI flash memory devices through the JTAG interface and the logic to control configuration from the flash memory device to the Cyclone IV device.

-  For more information about the PFL, refer to [AN 386: Using the Parallel Flash Loader with the Quartus II Software](#).
-  FPP configuration is supported in EP4CGX30 (only for F484 package), EP4CGX50, EP4CGX75, EP4CGX110, EP4CGX150, and all Cyclone IV E devices.
-  The FPP configuration is not supported in E144 package of Cyclone IV E devices.
-  Cyclone IV devices do not support enhanced configuration devices for FPP configuration.

### FPP Configuration Using an External Host

FPP configuration using an external host provides a fast method to configure Cyclone IV devices. In the FPP configuration scheme, you can use an external host device to control the transfer of configuration data from a storage device, such as flash memory, to the target Cyclone IV device. You can store configuration data in an **.rbf**, **.hex**, or **.ttf** format. When using the external host, a design that controls the configuration process, such as fetching the data from flash memory and sending it to

the device, must be stored in the external host device. Figure 8-19 shows the configuration interface connections between the Cyclone IV devices and an external device for single-device configuration.

**Figure 8-19. Single-Device FPP Configuration Using an External Host**

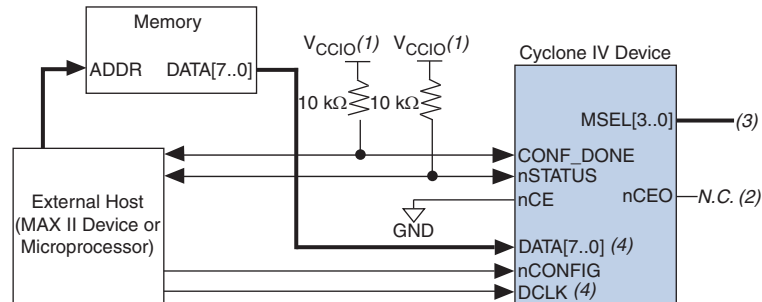

**Notes to Figure 8-19:**

- (1) Connect the pull-up resistor to a supply that provides an acceptable input signal for the device.  $V_{CC}$  must be high enough to meet the  $V_{IH}$  specification of the I/O on the device and the external host.
- (2) The  $nCEO$  pin is left unconnected or used as a user I/O pin when it does not feed the  $nCE$  pin of another device.
- (3) The  $MSEL$  pin settings vary for different configuration voltage standards and POR time. To connect the  $MSEL$  pins, refer to Table 8-4 on page 8-8 and Table 8-5 on page 8-9. Connect the  $MSEL$  pins directly to  $V_{CCA}$  or GND.
- (4) All I/O inputs must maintain a maximum AC voltage of 4.1 V.  $DATA[7..0]$  and  $DCLK$  must fit the maximum overshoot outlined in Equation 8-1 on page 8-5.

After  $nSTATUS$  is released, the device is ready to receive configuration data and the configuration stage begins. When  $nSTATUS$  is pulled high, the external host device places the configuration data one byte at a time on the  $DATA[7..0]$  pins.

Cyclone IV devices receive configuration data on the  $DATA[7..0]$  pins and the clock is received on the  $DCLK$  pin. Data is latched into the device on the rising edge of  $DCLK$ . Data is continuously clocked into the target device until  $CONF\_DONE$  goes high. The  $CONF\_DONE$  pin goes high one byte early in FPP configuration mode. The last byte is required for serial configuration (AS and PS) modes.

 Two  $DCLK$  falling edges are required after  $CONF\_DONE$  goes high to begin initialization of the device.

Supplying a clock on  $CLKUSR$  does not affect the configuration process. After the  $CONF\_DONE$  pin goes high,  $CLKUSR$  is enabled after the time specified as  $t_{CD2CU}$ . After this time period elapses, Cyclone IV devices require 3,192 clock cycles to initialize properly and enter user mode. For more information about the supported  $CLKUSR f_{MAX}$  value for Cyclone IV devices, refer to Table 8-13 on page 8-44.

The  $INIT\_DONE$  pin is released and pulled high when initialization is complete. The external host device must be able to detect this low-to-high transition, which signals the device has entered user mode. When initialization is complete, the device enters user mode. In user mode, the user I/O pins no longer have weak pull-up resistors and function as assigned in your design.

To ensure that DCLK and DATA[0] are not left floating at the end of the configuration, the MAX II device must drive them either high or low, whichever is convenient on your board. The DATA[0] pin is available as a user I/O pin after configuration. When you choose the FPP scheme in the Quartus II software, the DATA[0] pin is tri-stated by default in user mode and must be driven by the external host device. To change this default option in the Quartus II software, select the **Dual-Purpose Pins** tab of the **Device and Pin Options** dialog box.

The DCLK speed must be below the specified system frequency to ensure correct configuration. No maximum DCLK period exists, which means you can pause configuration by halting DCLK for an indefinite amount of time.

The external host device can also monitor the CONF\_DONE and INIT\_DONE pins to ensure successful configuration. The CONF\_DONE pin must be monitored by the external device to detect errors and to determine when programming is complete. If all configuration data is sent, but CONF\_DONE or INIT\_DONE has not gone high, the external device must reconfigure the target device.

Figure 8-20 shows how to configure multiple devices with a MAX II device. This circuit is similar to the FPP configuration circuit for a single device, except the Cyclone IV devices are cascaded for multi-device configuration.

**Figure 8-20. Multi-Device FPP Configuration Using an External Host**

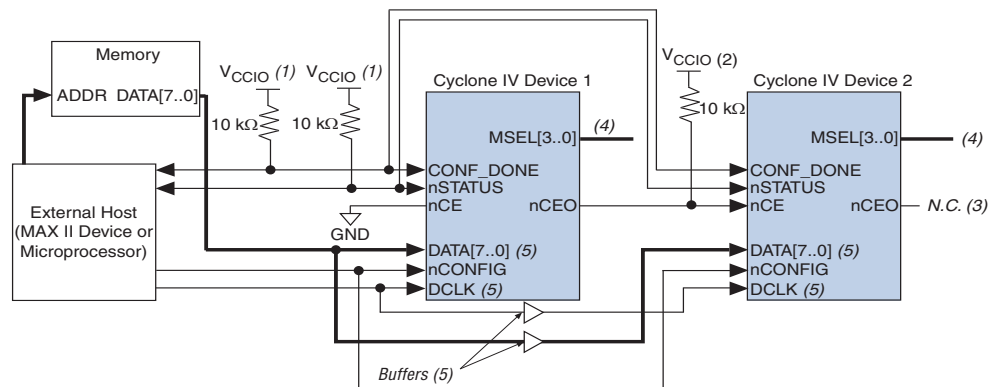

**Notes to Figure 8-20:**

- (1) The pull-up resistor must be connected to a supply that provides an acceptable input signal for all devices in the chain.  $V_{CC}$  must be high enough to meet the  $V_{IH}$  specification of the I/O on the device and the external host.
- (2) Connect the pull-up resistor to the  $V_{CCIO}$  supply voltage of the I/O bank in which the nCE pin resides.
- (3) The nCEO pin is left unconnected or used as a user I/O pin when it does not feed the nCE pin of another device.
- (4) The MSEL pin settings vary for different configuration voltage standards and POR time. To connect the MSEL pins, refer to Table 8-4 on page 8-8 and Table 8-5 on page 8-9. Connect the MSEL pins directly to  $V_{CCA}$  or GND.
- (5) All I/O inputs must maintain a maximum AC voltage of 4.1 V. DATA[7..0] and DCLK must fit the maximum overshoot outlined in Equation 8-1 on page 8-5.

After the first device completes configuration in a multi-device configuration chain, its nCEO pin drives low to activate the nCE pin of the second device, which prompts the second device to begin configuration. The second device in the chain begins configuration in one clock cycle; therefore, the transfer of data destinations is transparent to the MAX II device. All other configuration pins (nCONFIG, nSTATUS,

DCLK, DATA[7..0], and CONF\_DONE) are connected to every device in the chain. Configuration signals may require buffering to ensure signal integrity and prevent clock skew problems. Ensure that the DCLK and DATA lines are buffered. All devices initialize and enter user mode at the same time, because all device CONF\_DONE pins are tied together.

All nSTATUS and CONF\_DONE pins are tied together and if any device detects an error, configuration stops for the entire chain and the entire chain must be reconfigured. For example, if the first device flags an error on nSTATUS, it resets the chain by pulling its nSTATUS pin low. This behavior is similar to a single device detecting an error.

Figure 8-21 shows multi-device FPP configuration when both Cyclone IV devices are receiving the same configuration data. Configuration pins (nCONFIG, nSTATUS, DCLK, DATA[7..0], and CONF\_DONE) are connected to every device in the chain. Configuration signals may require buffering to ensure signal integrity and prevent clock skew problems. Ensure that the DCLK and DATA lines are buffered. Devices must be of the same density and package. All devices start and complete configuration at the same time.

**Figure 8-21. Multi-Device FPP Configuration Using an External Host When Both Devices Receive the Same Data**

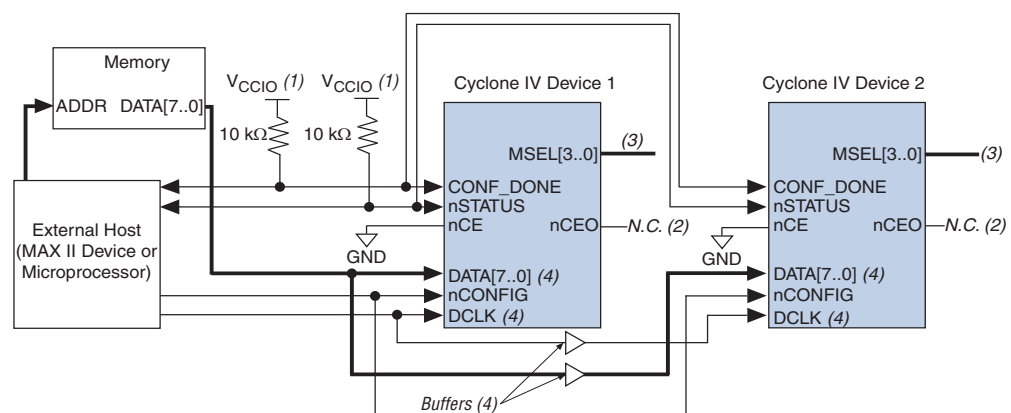

**Notes to Figure 8-21:**

- (1) You must connect the pull-up resistor to a supply that provides an acceptable input signal for all devices in the chain.  $V_{CC}$  must be high enough to meet the  $V_{IH}$  specification of the I/O on the device and the external host.
- (2) The nCEO pins of both devices are left unconnected or used as user I/O pins when configuring the same configuration data into multiple devices.
- (3) The MSEL pin settings vary for different configuration voltage standards and POR time. To connect the MSEL pins, refer to Table 8-4 on page 8-8 and Table 8-5 on page 8-9. Connect the MSEL pins directly to  $V_{CCA}$  or GND.
- (4) All I/O inputs must maintain a maximum AC voltage of 4.1 V. DATA[7..0] and DCLK must fit the maximum overshoot outlined in Equation 8-1 on page 8-5.

You can use a single configuration chain to configure Cyclone IV devices with other Altera devices that support FPP configuration. To ensure that all devices in the chain complete configuration at the same time or that an error flagged by one device starts reconfiguration in all devices, tie all the CONF\_DONE and nSTATUS pins together.



For more information about configuring multiple Altera devices in the same configuration chain, refer to *Configuring Mixed Altera FPGA Chains* in volume 2 of the *Configuration Handbook*.

## FPP Configuration Timing

Figure 8-22 shows the timing waveform for the FPP configuration when using an external host.

**Figure 8-22. FPP Configuration Timing Waveform (1)**

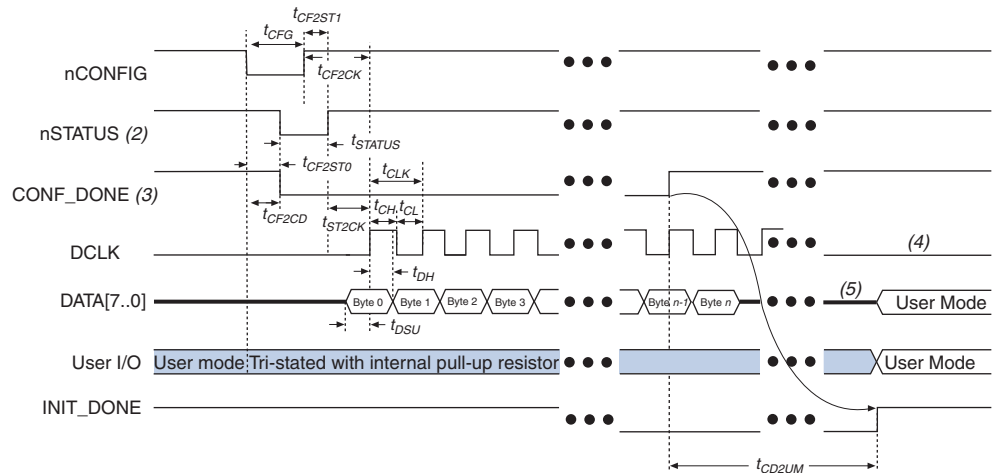

### Notes to Figure 8-22:

- (1) The beginning of this waveform shows the device in user mode. In user mode,  $nCONFIG$ ,  $nSTATUS$ , and  $CONF\_DONE$  are at logic-high levels. When  $nCONFIG$  is pulled low, a reconfiguration cycle begins.
- (2) After power up, the Cyclone IV device holds  $nSTATUS$  low during POR delay.
- (3) After power up, before and during configuration,  $CONF\_DONE$  is low.
- (4) Do not leave  $DCLK$  floating after configuration. It must be driven high or low, whichever is more convenient.
- (5)  $DATA[7..0]$  is available as a user I/O pin after configuration; the state of the pin depends on the dual-purpose pin settings.

Table 8-13 lists the FPP configuration timing parameters for Cyclone IV devices.

**Table 8-13. FPP Timing Parameters for Cyclone IV Devices (Part 1 of 2)**

Symbol	Parameter	Minimum		Maximum		Unit
		Cyclone IV (1)	Cyclone IV E (2)	Cyclone IV (1)	Cyclone IV E (2)	
$t_{CF2CD}$	$nCONFIG$ low to $CONF\_DONE$ low	—	—	500	—	ns
$t_{CF2ST0}$	$nCONFIG$ low to $nSTATUS$ low	—	—	500	—	ns
$t_{CFG}$	$nCONFIG$ low pulse width	500	—	—	—	ns
$t_{STATUS}$	$nSTATUS$ low pulse width	45	—	230 (3)	—	$\mu$ s
$t_{CF2ST1}$	$nCONFIG$ high to $nSTATUS$ high	—	—	230 (4)	—	$\mu$ s
$t_{CF2CK}$	$nCONFIG$ high to first rising edge on $DCLK$	230 (3)	—	—	—	$\mu$ s

**Table 8-13. FPP Timing Parameters for Cyclone IV Devices (Part 2 of 2)**

Symbol	Parameter	Minimum		Maximum		Unit
		Cyclone IV <sup>(1)</sup>	Cyclone IV E <sup>(2)</sup>	Cyclone IV <sup>(1)</sup>	Cyclone IV E <sup>(2)</sup>	
$t_{ST2CK}$	nSTATUS high to first rising edge of DCLK	2		—		μs
$t_{DH}$	Data hold time after rising edge on DCLK	0		—		ns
$t_{CD2UM}$	CONF_DONE high to user mode <sup>(5)</sup>	300		650		μs
$t_{CD2CU}$	CONF_DONE high to CLKUSR enabled	4 × maximum DCLK period		—		—
$t_{CD2UMC}$	CONF_DONE high to user mode with <b>CLKUSR</b> option on	$t_{CD2CU} + (3,192 \times \text{CLKUSR period})$		—		—
$t_{DSU}$	Data setup time before rising edge on DCLK	5	8	—	—	ns
$t_{CH}$	DCLK high time	3.2	6.4	—	—	ns
$t_{CL}$	DCLK low time	3.2	6.4	—	—	ns
$t_{CLK}$	DCLK period	7.5	15	—	—	ns
$f_{MAX}$	DCLK frequency <sup>(6)</sup>	—	—	133	66	MHz

**Notes to Table 8-13:**

- (1) Applicable for Cyclone IV GX and Cyclone IV E with 1.2-V core voltage.
- (2) Applicable for Cyclone IV E with 1.0-V core voltage.
- (3) This value is applicable if you do not delay configuration by extending the nCONFIG or nSTATUS low pulse width.
- (4) This value is applicable if you do not delay configuration by externally holding the nSTATUS low.
- (5) The minimum and maximum numbers apply only if you choose the internal oscillator as the clock source for starting the device.
- (6) Cyclone IV E devices with 1.0-V core voltage have slower  $F_{MAX}$  when compared with Cyclone IV GX devices with 1.2-V core voltage.

## JTAG Configuration

JTAG has developed a specification for boundary-scan testing (BST). The BST architecture offers the capability to efficiently test components on PCBs with tight lead spacing. The BST architecture can test pin connections without using physical test probes and capture functional data while a device is normally operating. You can also use the JTAG circuitry to shift configuration data into the device. The Quartus II software automatically generates .sof for JTAG configuration with a download cable in the Quartus II software Programmer.



For more information about the JTAG boundary-scan testing, refer to the [JTAG Boundary-Scan Testing for Cyclone IV Devices](#) chapter.

JTAG instructions have precedence over any other configuration modes. Therefore, JTAG configuration can take place without waiting for other configuration modes to complete. For example, if you attempt JTAG configuration in Cyclone IV devices during PS configuration, PS configuration terminates and JTAG configuration begins. If the MSEL pins are set to AS mode, the Cyclone IV device does not output a DCLK signal when JTAG configuration takes place.

The four required pins for a device operating in JTAG mode are TDI, TDO, TMS, and TCK. All the JTAG input pins are powered by the V<sub>CCIO</sub> pin and support the LVTTTL I/O standard only. All user I/O pins are tri-stated during JTAG configuration. [Table 8-14](#) explains the function of each JTAG pin.

**Table 8-14. Dedicated JTAG Pins**

Pin Name	Pin Type	Description
TDI	Test data input	Serial input pin for instructions as well as test and programming data. Data shifts in on the rising edge of TCK. If the JTAG interface is not required on the board, the JTAG circuitry is disabled by connecting this pin to V <sub>CC</sub> . TDI pin has weak internal pull-up resistors (typically 25 kΩ).
TDO	Test data output	Serial data output pin for instructions as well as test and programming data. Data shifts out on the falling edge of TCK. The pin is tri-stated if data is not being shifted out of the device. If the JTAG interface is not required on the board, the JTAG circuitry is disabled by leaving this pin unconnected.
TMS	Test mode select	Input pin that provides the control signal to determine the transitions of the TAP controller state machine. Transitions in the state machine occur on the rising edge of TCK. Therefore, TMS must be set up before the rising edge of TCK. TMS is evaluated on the rising edge of TCK. If the JTAG interface is not required on the board, the JTAG circuitry is disabled by connecting this pin to V <sub>CC</sub> . TMS pin has weak internal pull-up resistors (typically 25 kΩ).
TCK	Test clock input	The clock input to the BST circuitry. Some operations occur at the rising edge, while others occur at the falling edge. If the JTAG interface is not required on the board, the JTAG circuitry is disabled by connecting this pin to GND. The TCK pin has an internal weak pull-down resistor.

You can download data to the device through the USB-Blaster, MasterBlaster, ByteBlaster II, or ByteBlasterMV download cable, or the EthernetBlaster communications cable during JTAG configuration. Configuring devices with a cable is similar to programming devices in-system. [Figure 8-23](#) and [Figure 8-24](#) show the JTAG configuration of a single Cyclone IV device.

For device using  $V_{CCIO}$  of 2.5, 3.0, and 3.3 V, refer to [Figure 8-23](#). All I/O inputs must maintain a maximum AC voltage of 4.1 V because JTAG pins do not have the internal PCI clamping diodes to prevent voltage overshoot when using  $V_{CCIO}$  of 2.5, 3.0, and 3.3 V. You must power up the  $V_{CC}$  of the download cable with a 2.5-V supply from  $V_{CCA}$ . For device using  $V_{CCIO}$  of 1.2, 1.5, and 1.8 V, refer to [Figure 8-24](#). You can power up the  $V_{CC}$  of the download cable with the supply from  $V_{CCIO}$ .

**Figure 8-23. JTAG Configuration of a Single Device Using a Download Cable (2.5, 3.0, and 3.3-V  $V_{CCIO}$  Powering the JTAG Pins)**

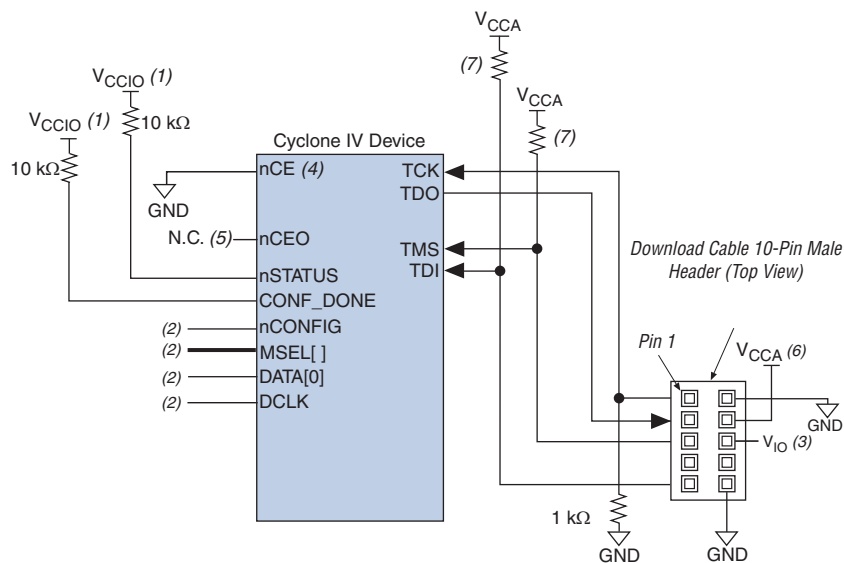

**Notes to Figure 8-23:**

- (1) Connect these pull-up resistors to the  $V_{CCIO}$  supply of the bank in which the pin resides.
- (2) Connect the  $nCONFIG$  and  $MSEL$  pins to support a non-JTAG configuration scheme. If you only use JTAG configuration, connect the  $nCONFIG$  pin to logic-high and the  $MSEL$  pins to GND. In addition, pull  $DCLK$  and  $DATA[0]$  to either high or low, whichever is convenient on your board.
- (3) Pin 6 of the header is a  $V_{IO}$  reference voltage for the MasterBlaster output driver.  $V_{IO}$  must match the device's  $V_{CCA}$ . For this value, refer to the [MasterBlaster Serial/USB Communications Cable User Guide](#). When using the USB-Blaster, ByteBlaster II, ByteBlasterMV, and EthernetBlaster cables, this pin is a no connect.
- (4) The  $nCE$  pin must be connected to GND or driven low for successful JTAG configuration.
- (5) The  $nCEO$  pin is left unconnected or used as a user I/O pin when it does not feed the  $nCE$  pin of another device.
- (6) Power up the  $V_{CC}$  of the EthernetBlaster, ByteBlaster II, USB-Blaster, or ByteBlasterMV cable with a 2.5-V supply from  $V_{CCA}$ . Third-party programmers must switch to 2.5 V. Pin 4 of the header is a  $V_{CC}$  power supply for the MasterBlaster cable. The MasterBlaster cable can receive power from either 5.0- or 3.3-V circuit boards, DC power supply, or 5.0 V from the USB cable. For this value, refer to the [MasterBlaster Serial/USB Communications Cable User Guide](#).
- (7) Resistor value can vary from 1 k $\Omega$  to 10 k $\Omega$ .

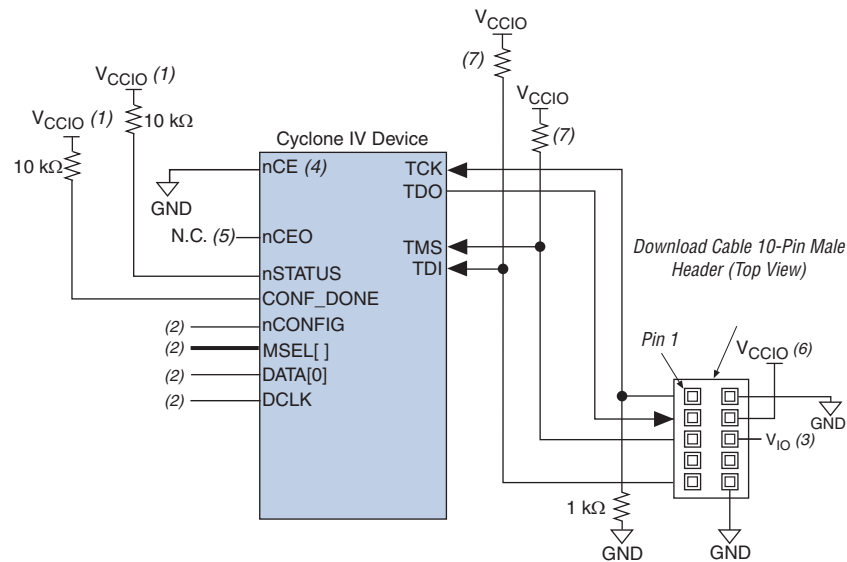
**Figure 8-24. JTAG Configuration of a Single Device Using a Download Cable (1.5-V or 1.8-V  $V_{CCIO}$  Powering the JTAG Pins)****Notes to Figure 8-24:**

- (1) Connect these pull-up resistors to the  $V_{CCIO}$  supply of the bank in which the pin resides.
- (2) Connect the  $nCONFIG$  and  $MSEL$  pins to support a non-JTAG configuration scheme. If you only use JTAG configuration, connect the  $nCONFIG$  pin to logic-high and the  $MSEL$  pins to GND. In addition, pull  $DCLK$  and  $DATA[0]$  to either high or low, whichever is convenient on your board.
- (3) In the USB-Blaster and ByteBlaster II cables, this pin is connected to  $nCE$  when it is used for AS programming; otherwise it is a no connect.
- (4) The  $nCE$  must be connected to GND or driven low for successful JTAG configuration.
- (5) The  $nCEO$  pin is left unconnected or used as a user I/O pin when it does not feed the  $nCE$  pin of another device.
- (6) Power up the  $V_{CC}$  of the EthernetBlaster, ByteBlaster II or USB-Blaster cable with supply from  $V_{CCIO}$ . The Ethernet-Blaster, ByteBlaster II, and USB-Blaster cables do not support a target supply voltage of 1.2 V. For the target supply voltage value, refer to the *ByteBlaster II Download Cable User Guide*, the *USB-Blaster Download Cable User Guide*, and the *EthernetBlaster Communications Cable User Guide*.
- (7) Resistor value can vary from 1 k $\Omega$  to 10 k $\Omega$ .

To configure a single device in a JTAG chain, the programming software places all other devices in bypass mode. In bypass mode, devices pass programming data from the TDI pin to the TDO pin through a single bypass register without being affected internally. This scheme enables the programming software to program or verify the target device. Configuration data driven into the device appears on the TDO pin one clock cycle later.

The Quartus II software verifies successful JTAG configuration after completion. At the end of configuration, the software checks the state of  $CONF\_DONE$  through the JTAG port. When Quartus II generates a **.jam** for a multi-device chain, it contains instructions so that all the devices in the chain are initialized at the same time. If  $CONF\_DONE$  is not high, the Quartus II software indicates that configuration has failed. If  $CONF\_DONE$  is high, the software indicates that configuration was successful. After the configuration bitstream is serially sent using the JTAG TDI port, the TCK port clocks an additional clock cycles to perform device initialization.

You can perform JTAG testing on Cyclone IV devices before, during, and after configuration. Cyclone IV devices support the `BYPASS`, `IDCODE`, and `SAMPLE` instructions during configuration without interrupting configuration. All other JTAG instructions can only be issued by first interrupting configuration and reprogramming I/O pins with the `ACTIVE_DISENGAGE` and `CONFIG_IO` instructions.

The `CONFIG_IO` instruction allows you to configure the I/O buffers through the JTAG port and interrupts configuration when issued after the `ACTIVE_DISENGAGE` instruction. This instruction allows you to perform board-level testing prior to configuring the Cyclone IV device or waiting for a configuration device to complete configuration. Prior to issuing the `CONFIG_IO` instruction, you must issue the `ACTIVE_DISENGAGE` instruction. This is because in Cyclone IV devices, the `CONFIG_IO` instruction does not hold `nSTATUS` low until reconfiguration, so you must disengage the active configuration mode controller when active configuration is interrupted. The `ACTIVE_DISENGAGE` instruction places the active configuration mode controllers in an idle state prior to JTAG programming. Additionally, the `ACTIVE_ENGAGE` instruction allows you to re-engage a disengaged active configuration mode controller.

 You must follow a specific flow when executing the `ACTIVE_DISENGAGE`, `CONFIG_IO`, and `ACTIVE_ENGAGE` JTAG instructions in Cyclone IV devices.

The chip-wide reset (`DEV_CLRn`) and chip-wide output enable (`DEV_OE`) pins in Cyclone IV devices do not affect JTAG boundary-scan or programming operations. Toggling these pins do not affect JTAG operations (other than the usual boundary-scan operation).

When designing a board for JTAG configuration of Cyclone IV devices, consider the dedicated configuration pins. [Table 8-15](#) describes how you must connect these pins during JTAG configuration.

**Table 8-15. Dedicated Configuration Pin Connections During JTAG Configuration**

Signal	Description
<code>nCE</code>	On all Cyclone IV devices in the chain, <code>nCE</code> must be driven low by connecting it to GND, pulling it low through a resistor, or driving it by some control circuitry. For devices that are also in multi-device AS, AP, PS, or FPP configuration chains, you must connect the <code>nCE</code> pins to GND during JTAG configuration or JTAG configured in the same order as the configuration chain.
<code>nCEO</code>	On all Cyclone IV devices in the chain, <code>nCEO</code> is left floating or connected to the <code>nCE</code> of the next device.
<code>MSEL</code>	These pins must not be left floating. These pins support whichever non-JTAG configuration that you used in production. If you only use JTAG configuration, tie these pins to GND.
<code>nCONFIG</code>	Driven high by connecting to the <code>V<sub>CCIO</sub></code> supply of the bank in which the pin resides and pulling up through a resistor or driven high by some control circuitry.
<code>nSTATUS</code>	Pull to the <code>V<sub>CCIO</sub></code> supply of the bank in which the pin resides through a 10-k $\Omega$ resistor. When configuring multiple devices in the same JTAG chain, each <code>nSTATUS</code> pin must be pulled up to the <code>V<sub>CCIO</sub></code> individually.
<code>CONF_DONE</code>	Pull to the <code>V<sub>CCIO</sub></code> supply of the bank in which the pin resides through a 10-k $\Omega$ resistor. When configuring multiple devices in the same JTAG chain, each <code>CONF_DONE</code> pin must be pulled up to <code>V<sub>CCIO</sub></code> supply of the bank in which the pin resides individually. <code>CONF_DONE</code> going high at the end of JTAG configuration indicates successful configuration.
<code>DCLK</code>	Must not be left floating. Drive low or high, whichever is more convenient on your board.

When programming a JTAG device chain, one JTAG-compatible header is connected to several devices. The number of devices in the JTAG chain is limited only by the drive capability of the download cable. When four or more devices are connected in a JTAG chain, Altera recommends buffering the TCK, TDI, and TMS pins with an on-board buffer.

JTAG-chain device programming is ideal when the system contains multiple devices, or when testing your system with JTAG BST circuitry. Figure 8-25 and Figure 8-26 show multi-device JTAG configuration.

For devices using 2.5-, 3.0-, and 3.3-V  $V_{CCIO}$  supply, you must refer to Figure 8-25. All I/O inputs must maintain a maximum AC voltage of 4.1 V because JTAG pins do not have the internal PCI clamping diodes to prevent voltage overshoot when using 2.5-, 3.0-, and 3.3-V  $V_{CCIO}$  supply. You must power up the  $V_{CC}$  of the download cable with a 2.5-V  $V_{CCA}$  supply. For device using  $V_{CCIO}$  of 1.2, 1.5 V, and 1.8 V, refer to Figure 8-26. You can power up the  $V_{CC}$  of the download cable with the supply from  $V_{CCIO}$ .

**Figure 8-25. JTAG Configuration of Multiple Devices Using a Download Cable (2.5, 3.0, and 3.3-V  $V_{CCIO}$  Powering the JTAG Pins)**

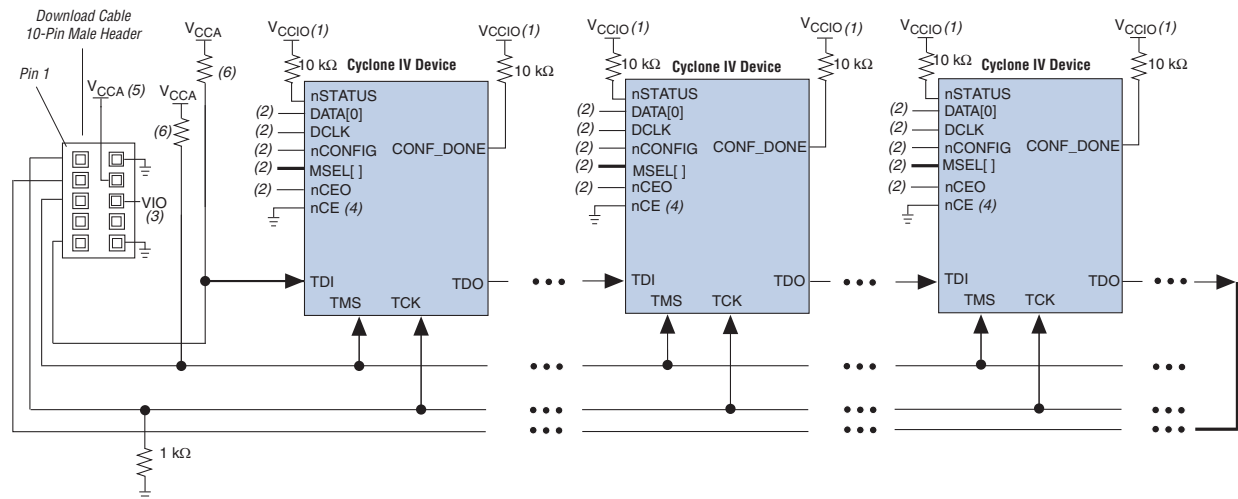

**Notes to Figure 8-25:**

- (1) Connect these pull-up resistors to the  $V_{CCIO}$  supply of the bank in which the pin resides.
- (2) Connect the nCONFIG and MSEL pins to support a non-JTAG configuration scheme. If you only use a JTAG configuration, connect the nCONFIG pin to logic-high and the MSEL pins to GND. In addition, pull DCLK and DATA[0] to either high or low, whichever is convenient on your board.
- (3) Pin 6 of the header is a  $V_{IO}$  reference voltage for the MasterBlaster output driver.  $V_{IO}$  must match the  $V_{CCA}$  of the device. For this value, refer to the [MasterBlaster Serial/USB Communications Cable User Guide](#). In the ByteBlasterMV cable, this pin is a no connect. In the USB-Blaster and ByteBlaster II cables, this pin is connected to nCE when it is used for AS programming, otherwise it is a no connect.
- (4) You must connect the nCE pin to GND or driven low for successful JTAG configuration.
- (5) Power up the  $V_{CC}$  of the ByteBlaster II, USB-Blaster, or ByteBlasterMV cable with a 2.5-V supply from  $V_{CCA}$ . Third-party programmers must switch to 2.5 V. Pin 4 of the header is a  $V_{CC}$  power supply for the MasterBlaster cable. The MasterBlaster cable can receive power from either 5.0- or 3.3-V circuit boards, DC power supply, or 5.0 V from the USB cable. For this value, refer to the [MasterBlaster Serial/USB Communications Cable User Guide](#).
- (6) Resistor value can vary from 1 kΩ to 10 kΩ.

**Figure 8-26. JTAG Configuration of Multiple Devices Using a Download Cable (1.2, 1.5, and 1.8-V  $V_{CCIO}$  Powering the JTAG Pins)**

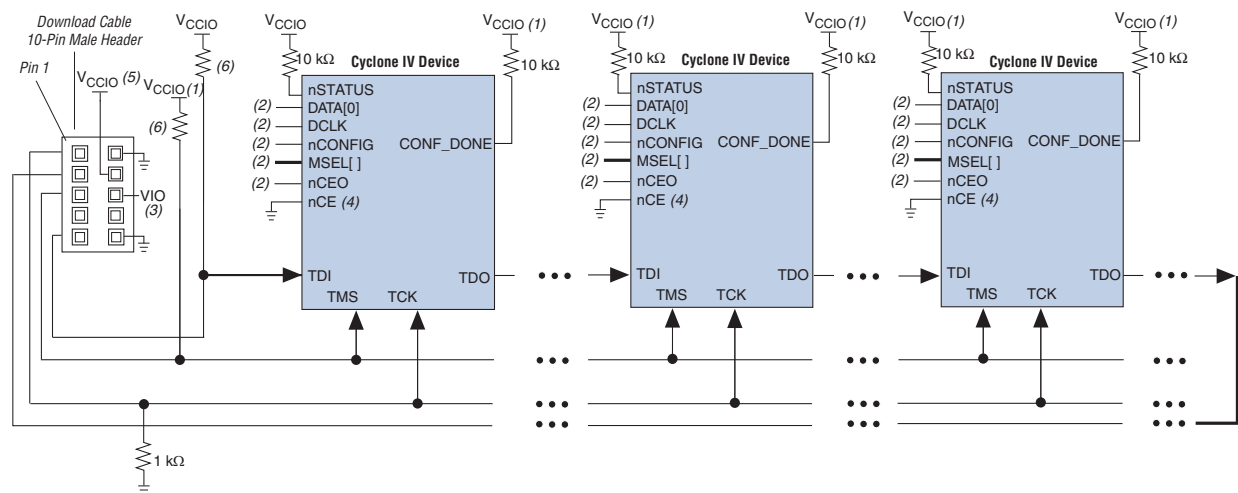

**Notes to Figure 8-26:**

- (1) Connect these pull-up resistors to the  $V_{CCIO}$  supply of the bank in which the pin resides.
- (2) Connect the  $nCONFIG$  and  $MSEL$  pins to support a non-JTAG configuration scheme. If you only use a JTAG configuration, connect the  $nCONFIG$  pin to logic-high and the  $MSEL$  pins to GND. In addition, pull  $DCLK$  and  $DATA[0]$  to either high or low, whichever is convenient on your board.
- (3) In the USB-Blaster and ByteBlaster II cable, this pin is connected to  $nCE$  when it is used for AS programming, otherwise it is a no connect.
- (4) You must connect the  $nCE$  pin to GND or driven low for successful JTAG configuration.
- (5) Power up the  $V_{CC}$  of the ByteBlaster II or USB-Blaster cable with supply from  $V_{CCIO}$ . The ByteBlaster II and USB-Blaster cables do not support a target supply voltage of 1.2 V. For the target supply voltage value, refer to the [ByteBlaster II Download Cable User Guide](#) and the [USB-Blaster Download Cable User Guide](#).
- (6) Resistor value can vary from 1 k $\Omega$  to 10 k $\Omega$ .

If a non-Cyclone IV device is cascaded in the JTAG-chain, TDO of the non-Cyclone IV device driving into TDI of the Cyclone IV device must fit the maximum overshoot outlined in [Equation 8-1](#) on page 8-5.

The  $CONF\_DONE$  and  $nSTATUS$  signals are shared in multi-device AS, AP, PS, and FPP configuration chains to ensure that the devices enter user mode at the same time after configuration is complete. When the  $CONF\_DONE$  and  $nSTATUS$  signals are shared among all the devices, you must configure every device when JTAG configuration is performed.

If you only use JTAG configuration, Altera recommends that you connect the circuitry as shown in [Figure 8-25](#) or [Figure 8-26](#), in which each of the  $CONF\_DONE$  and  $nSTATUS$  signals are isolated so that each device can enter user mode individually.

After the first device completes configuration in a multi-device configuration chain, its  $nCEO$  pin drives low to activate the  $nCE$  pin of the second device, which prompts the second device to begin configuration. Therefore, if these devices are also in a JTAG chain, ensure that the  $nCE$  pins are connected to GND during JTAG configuration or that the devices are JTAG configured in the same order as the configuration chain. As long as the devices are JTAG configured in the same order as the multi-device configuration chain, the  $nCEO$  of the previous device drives the  $nCE$  pin of the next device low when it has successfully been JTAG configured. You can place other Altera devices that have JTAG support in the same JTAG chain for device programming and configuration.



-  JTAG configuration allows an unlimited number of Cyclone IV devices to be cascaded in a JTAG chain.
-  For more information about configuring multiple Altera devices in the same configuration chain, refer to the *Configuring Mixed Altera FPGA Chains* chapter in volume 2 of the *Configuration Handbook*.

Figure 8-27 shows JTAG configuration with a Cyclone IV device and a microprocessor.

**Figure 8-27. JTAG Configuration of a Single Device Using a Microprocessor**

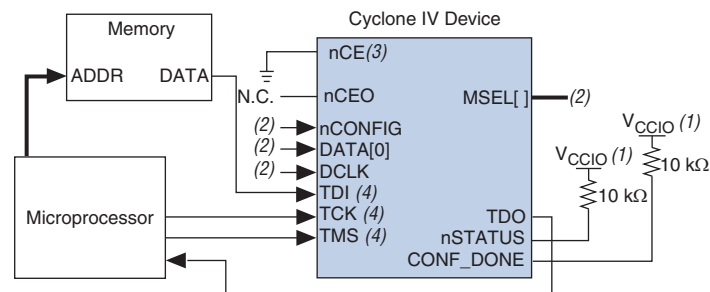

**Notes to Figure 8-27:**

- (1) You must connect the pull-up resistor to a supply that provides an acceptable input signal for all devices in the chain.
- (2) Connect the nCONFIG and MSEL pins to support a non-JTAG configuration scheme. If you only use a JTAG configuration, connect the nCONFIG pin to logic-high and the MSEL pins to GND. In addition, pull DCLK and DATA[0] to either high or low, whichever is convenient on your board.
- (3) You must connect the nCE pin to GND or driven low for successful JTAG configuration.
- (4) All I/O inputs must maintain a maximum AC voltage of 4.1 V. Signals driving into TDI, TMS, and TCK must fit the maximum overshoot outlined in Equation 8-1 on page 8-5.



### Configuring Cyclone IV Devices with Jam STAPL

Jam™ STAPL, JEDEC standard JESD-71, is a standard file format for in-system programmability (ISP) purposes. Jam STAPL supports programming or configuration of programmable devices and testing of electronic systems, using the IEEE 1149.1 JTAG interface. Jam STAPL is a freely licensed open standard. The Jam Player provides an interface for manipulating the IEEE Std. 1149.1 JTAG TAP state machine.

-  For more information about JTAG and Jam STAPL in embedded environments, refer to *AN 425: Using Command-Line Jam STAPL Solution for Device Programming*. To download the Jam Player, visit the Altera website ([www.altera.com](http://www.altera.com)).

### Configuring Cyclone IV Devices with the JRunner Software Driver

The JRunner software driver allows you to configure Cyclone IV devices through the ByteBlaster II or ByteBlasterMV cables in JTAG mode. The supported programming input file is in .rbf format. The JRunner software driver also requires a Chain Description File (.cdf) generated by the Quartus II software. The JRunner software driver is targeted for embedded JTAG configuration. The source code is developed for the Windows NT operating system (OS). You can customize the code to make it run on your embedded platform.

-  The **.rbf** used by the JRunner software driver cannot be a compressed **.rbf** because the JRunner software driver uses JTAG-based configuration. During JTAG-based configuration, the real-time decompression feature is not available.
  
-  For more information about the JRunner software driver, refer to *AN 414: JRunner Software Driver: An Embedded Solution for PLD JTAG Configuration* and the source files on the Altera website at ([www.altera.com](http://www.altera.com)).

### Combining JTAG and AS Configuration Schemes

You can combine the AS configuration scheme with the JTAG-based configuration (Figure 8-28). This setup uses two 10-pin download cable headers on the board. One download cable is used in JTAG mode to configure the Cyclone IV device directly through the JTAG interface. The other download cable is used in AS mode to program the serial configuration device in-system through the AS programming interface. If you try configuring the device using both schemes simultaneously, JTAG configuration takes precedence and AS configuration terminates.

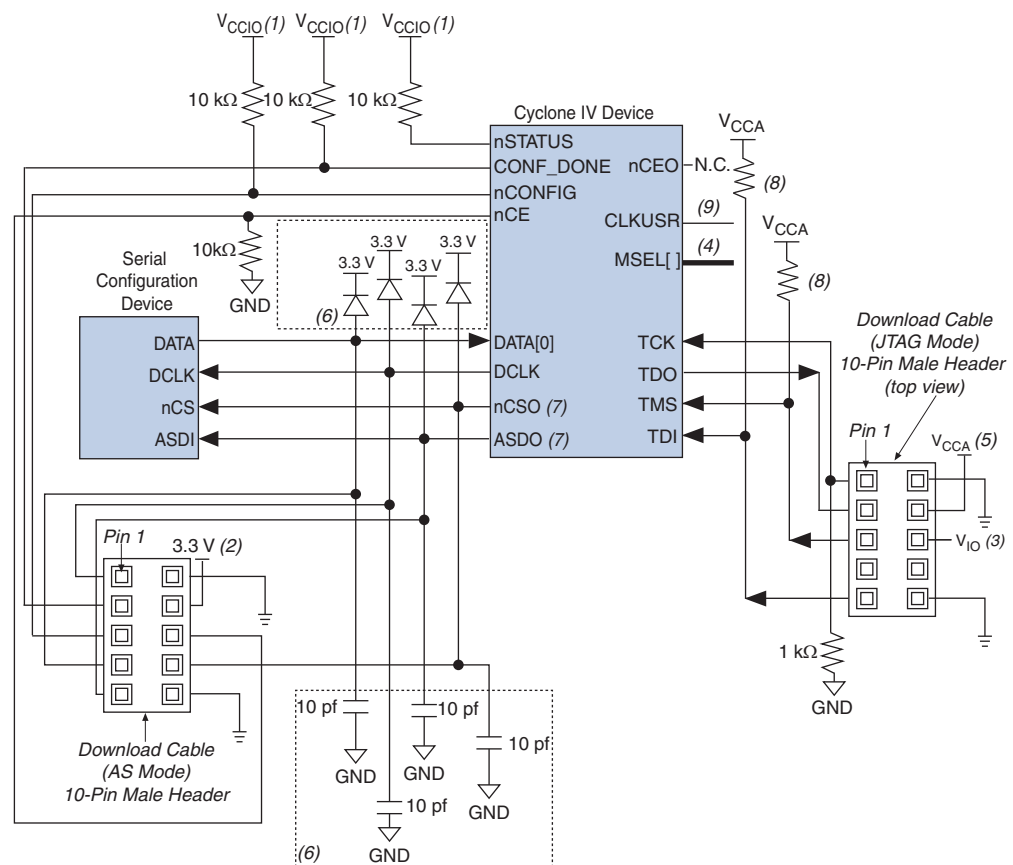
**Figure 8-28. Combining JTAG and AS Configuration Schemes****Notes to Figure 8-28:**

- (1) Connect these pull-up resistors to the  $V_{CCIO}$  supply of the bank in which the pin resides.
- (2) Power up the  $V_{CC}$  of the EthernetBlaster, ByteBlaster II, or USB-Blaster cable with the 3.3-V supply.
- (3) Pin 6 of the header is a  $V_{IO}$  reference voltage for the MasterBlaster output driver. The  $V_{IO}$  must match the  $V_{CCA}$  of the device. For this value, refer to the *MasterBlaster Serial/USB Communications Cable User Guide*. When using the ByteBlasterMV download cable, this pin is a no connect. When using the USB-Blaster and ByteBlaster II cables, this pin is connected to  $nCE$  when it is used for AS programming, otherwise it is a no connect.
- (4) The  $MSEL$  pin settings vary for different configuration voltage standards and POR time. To connect  $MSEL$  for AS configuration schemes, refer to [Table 8-3 on page 8-8](#), [Table 8-4 on page 8-8](#), and [Table 8-5 on page 8-9](#). Connect the  $MSEL$  pins directly to  $V_{CCA}$  or GND.
- (5) Power up the  $V_{CC}$  of the EthernetBlaster, ByteBlaster II, USB-Blaster, or ByteBlasterMV cable with a 2.5-V  $V_{CCA}$  supply. Third-party programmers must switch to 2.5 V. Pin 4 of the header is a  $V_{CC}$  power supply for the MasterBlaster cable. The MasterBlaster cable can receive power from either 5.0- or 3.3-V circuit boards, DC power supply, or 5.0 V from the USB cable. For this value, refer to the *MasterBlaster Serial/USB Communications Cable User Guide*.
- (6) You must place the diodes and capacitors as close as possible to the Cyclone IV device. Altera recommends using the Schottky diode, which has a relatively lower forward diode voltage (VF) than the switching and Zener diodes, for effective voltage clamping.
- (7) These pins are dual-purpose I/O pins. The  $nCSO$  pin functions as  $FLASH\_nCE$  pin in AP mode. The  $ASDI$  pin functions as  $DATA[1]$  pin in AP and FPP modes.
- (8) Resistor value can vary from 1 k $\Omega$  to 10 k $\Omega$ .
- (9) Only Cyclone IV GX devices have an option to select  $CLKUSR$  (40 MHz maximum) as the external clock source for DCLK.

## Programming Serial Configuration Devices In-System with the JTAG Interface

Cyclone IV devices in a single- or multiple-device chain support in-system programming of a serial configuration device with the JTAG interface through the SFL design. The intelligent host or download cable of the board can use the four JTAG pins on the Cyclone IV device to program the serial configuration device in system, even if the host or download cable cannot access the configuration pins (DCLK, DATA, ASDI, and nCS pins).

The SFL design is a JTAG-based in-system programming solution for Altera serial configuration devices. The SFL is a bridge design for the Cyclone IV device that uses their JTAG interface to access the EPCS JTAG Indirect Configuration Device Programming (.jic) file and then uses the AS interface to program the EPCS device. Both the JTAG interface and AS interface are bridged together inside the SFL design.

In a multiple device chain, you must only configure the master device that controls the serial configuration device. Slave devices in the multiple device chain that are configured by the serial configuration device do not have to be configured when using this feature. To successfully use this feature, set the MSEL pins of the master device to select the AS configuration scheme (Table 8-3 on page 8-8, Table 8-4 on page 8-8, and Table 8-5 on page 8-9). The serial configuration device in-system programming through the Cyclone IV device JTAG interface has three stages, which are described in the following sections:

- “Loading the SFL Design”
- “ISP of the Configuration Device” on page 8-56
- “Reconfiguration” on page 8-57

### Loading the SFL Design

The SFL design is a design inside the Cyclone IV device that bridges the JTAG interface and AS interface with glue logic.

The intelligent host uses the JTAG interface to configure the master device with a SFL design. The SFL design allows the master device to control the access of four serial configuration device pins, also known as the Active Serial Memory Interface (ASMI) pins, through the JTAG interface. The ASMI pins are serial clock input (DCLK), serial data output (DATA), AS data input (ASDI), and active-low chip select (nCS) pins.

If you configure a master device with an SFL design, the master device enters user mode even though the slave devices in the multiple device chain are not being configured. The master device enters user mode with a SFL design even though the CONF\_DONE signal is externally held low by the other slave devices in chain.

Figure 8-29 shows the JTAG configuration of a single Cyclone IV device with a SFL design.

**Figure 8-29. Programming Serial Configuration Devices In-System Using the JTAG Interface**

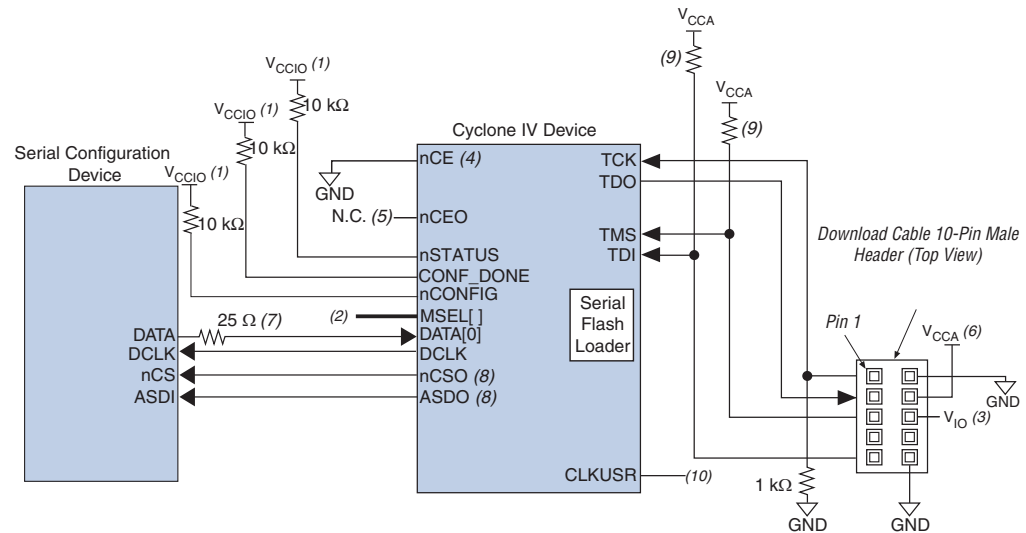

**Notes to Figure 8-29:**

- (1) Connect the pull-up resistors to the  $V_{CCIO}$  supply of the bank in which the pin resides.
- (2) The MSEL pin settings vary for different configuration voltage standards and POR time. To connect MSEL for AS configuration schemes, refer to Table 8-3 on page 8-8, Table 8-4 on page 8-8, and Table 8-5 on page 8-9. Connect the MSEL pins directly to  $V_{CCA}$  or GND.
- (3) Pin 6 of the header is a  $V_{IO}$  reference voltage for the MasterBlaster output driver. The  $V_{IO}$  must match the  $V_{CCA}$  of the device. For this value, refer to the *MasterBlaster Serial/USB Communications Cable User Guide*. When using the ByteBlasterMV download cable, this pin is a no connect. When using USB-Blaster, ByteBlaster II, and EthernetBlaster cables, this pin is connected to nCE when it is used for AS programming, otherwise it is a no connect.
- (4) You must connect the nCE pin to GND or driven low for successful JTAG configuration.
- (5) The nCEO pin is left unconnected or used as a user I/O pin when it does not feed the nCE pin of another device.
- (6) Power up the  $V_{CC}$  of the EthernetBlaster, ByteBlaster II, USB-Blaster, or ByteBlasterMV cable with a 2.5-  $V_{CCA}$  supply. Third-party programmers must switch to 2.5 V. Pin 4 of the header is a  $V_{CC}$  power supply for the MasterBlaster cable. The MasterBlaster cable can receive power from either 5.0- or 3.3-V circuit boards, DC power supply, or 5.0 V from the USB cable. For this value, refer to the *MasterBlaster Serial/USB Communications Cable User Guide*.
- (7) Connect the series resistor at the near end of the serial configuration device.
- (8) These pins are dual-purpose I/O pins. The nCSO pin functions as FLASH\_nCE pin in AP mode. The ASDO pin functions as DATA[1] pin in AP and FPP modes.
- (9) Resistor value can vary from 1 kΩ to 10 kΩ.
- (10) Only Cyclone IV GX devices have an option to select CLKUSR (40 MHz maximum) as the external clock source for DCCLK.

**ISP of the Configuration Device**

In the second stage, the SFL design in the master device allows you to write the configuration data for the device chain into the serial configuration device with the Cyclone IV device JTAG interface. The JTAG interface sends the programming data for the serial configuration device to the Cyclone IV device first. The Cyclone IV device then uses the ASMI pins to send the data to the serial configuration device.

## Reconfiguration

After the configuration data is successfully written into the serial configuration device, the Cyclone IV device does not automatically start reconfiguration. The intelligent host issues the `PULSE_NCONFIG` JTAG instruction to initialize the reconfiguration process. During reconfiguration, the master device is reset and the SFL design no longer exists in the Cyclone IV device and the serial configuration device configures all the devices in the chain with the user design.

 For more information about the SFL, refer to *AN 370: Using the Serial FlashLoader with Quartus II Software*.

## JTAG Instructions

 For more information about the JTAG binary instruction code, refer to the *JTAG Boundary-Scan Testing for Cyclone IV Devices* chapter.

## I/O Reconfiguration

Use the `CONFIG_IO` instruction to reconfigure the I/O configuration shift register (IOCSR) chain. This instruction allows you to perform board-level testing prior to configuring the Cyclone IV device or waiting for a configuration device to complete configuration. After the configuration is interrupted and JTAG testing is complete, you must reconfigure the part through the `PULSE_NCONFIG` JTAG instruction or by pulsing the `nCONFIG` pin low.

You can issue the `CONFIG_IO` instruction any time during user mode.

You must meet the following timing restrictions when using the `CONFIG_IO` instruction:

- The `CONFIG_IO` instruction cannot be issued when the `nCONFIG` pin is low
- You must observe a 230  $\mu$ s minimum wait time after any of the following conditions:
  - `nCONFIG` pin goes high
  - Issuing the `PULSE_NCONFIG` instruction
  - Issuing the `ACTIVE_ENGAGE` instruction, before issuing the `CONFIG_IO` instruction
- You must wait 230  $\mu$ s after power up, with the `nCONFIG` pin high before issuing the `CONFIG_IO` instruction (or wait for the `nSTATUS` pin to go high)

Use the ACTIVE\_DISENGAGE instruction with the CONFIG\_IO instruction to interrupt configuration. Table 8-16 lists the sequence of instructions to use for various CONFIG\_IO usage scenarios.

**Table 8-16. JTAG CONFIG\_IO (without JTAG\_PROGRAM) Instruction Flows <sup>(1)</sup>**

JTAG Instruction	Configuration Scheme and Current State of the Cyclone IV Device											
	Prior to User Mode (Interrupting Configuration)				User Mode				Power Up			
	PS	FPP	AS	AP	PS	FPP	AS	AP	PS	FPP	AS	AP
ACTIVE_DISENGAGE	0	0	0	0	0	0	0	0	—	—	—	—
CONFIG_IO	R	R	R	R	R	R	R	R	NA	NA	NA	NA
JTAG Boundary Scan Instructions (no JTAG_PROGRAM)	0	0	0	0	0	0	0	0	—	—	—	—
ACTIVE_ENGAGE	A	A	R <sup>(2)</sup>	R <sup>(2)</sup>	A	A	R <sup>(2)</sup>	R <sup>(2)</sup>	—	—	—	—
PULSE_NCONFIG			A <sup>(3)</sup>	A <sup>(3)</sup>			0	0	—	—	—	—
Pulse nCONFIG pin			A <sup>(3)</sup>	A <sup>(3)</sup>			0	0	—	—	—	—
JTAG TAP Reset	R	R	R	R	R	R	R	R	—	—	—	—

**Notes to Table 8-16:**

- (1) You must execute “R” indicates that the instruction before the next instruction, “0” indicates the optional instruction, “A” indicates that the instruction must be executed, and “NA” indicates that the instruction is not allowed in this mode.
- (2) Required if you use ACTIVE\_DISENGAGE.
- (3) Neither of the instruction is required if you use ACTIVE\_ENGAGE.

The CONFIG\_IO instruction does not hold nSTATUS low until reconfiguration. You must disengage the AS or AP configuration controller by issuing the ACTIVE\_DISENGAGE and ACTIVE\_ENGAGE instructions when active configuration is interrupted. You must issue the ACTIVE\_DISENGAGE instruction alone or prior to the CONFIG\_IO instruction if the JTAG\_PROGRAM instruction is to be issued later (Table 8-17). This puts the active configuration controllers into the idle state. The active configuration controller is re-engaged after user mode is reached through JTAG programming (Table 8-17).



While executing the CONFIG\_IO instruction, all user I/Os are tri-stated.

If reconfiguration after interruption is performed using configuration modes (rather than using JTAG\_PROGRAM), it is not necessary to issue the ACTIVE\_DISENGAGE instruction prior to CONFIG\_IO. You can start reconfiguration by either pulling nCONFIG low for at least 500 ns or issuing the PULSE\_NCONFIG instruction. If the ACTIVE\_DISENGAGE instruction was issued and the JTAG\_PROGRAM instruction fails to enter user mode, you must issue the ACTIVE\_ENGAGE instruction to reactivate the active configuration controller. Issuing the ACTIVE\_ENGAGE instruction also triggers reconfiguration in configuration modes; therefore, it is not necessary to pull nCONFIG low or issue the PULSE\_NCONFIG instruction.

### ACTIVE\_DISENGAGE

The ACTIVE\_DISENGAGE instruction places the active configuration controller (AS and AP) into an idle state prior to JTAG programming. The two purposes of placing the active controller in an idle state are:

- To ensure that it is not trying to configure the device during JTAG programming
- To allow the controllers to properly recognize a successful JTAG programming that results in the device reaching user mode

The ACTIVE\_DISENGAGE instruction is required before JTAG programming regardless of the current state of the Cyclone IV device if the MSEL pins are set to an AS or AP configuration scheme. If the ACTIVE\_DISENGAGE instruction is issued during a passive configuration scheme (PS or FPP), it has no effect on the Cyclone IV device. Similarly, the CONFIG\_IO instruction is issued after an ACTIVE\_DISENGAGE instruction, but is no longer required to properly halt configuration. Table 8-17 lists the required, recommended, and optional instructions for each configuration mode. The ordering of the required instructions is a hard requirement and must be met to ensure functionality.

**Table 8-17. JTAG Programming Instruction Flows (1)**

JTAG Instruction	Configuration Scheme and Current State of the Cyclone IV Device											
	Prior to User Mode (Interrupting Configuration)				User Mode				Power Up			
	PS	FPP	AS	AP	PS	FPP	AS	AP	PS	FPP	AS	AP
ACTIVE_DISENGAGE	O	O	R	R	O	O	O	R	O	O	R	R
CONFIG_IO	Rc	Rc	O	O	O	O	O	O	NA	NA	NA	NA
Other JTAG instructions	O	O	O	O	O	O	O	O	O	O	O	O
JTAG_PROGRAM	R	R	R	R	R	R	R	R	R	R	R	R
CHECK_STATUS	Rc	Rc	Rc	Rc	Rc	Rc	Rc	Rc	Rc	Rc	Rc	Rc
JTAG_STARTUP	R	R	R	R	R	R	R	R	R	R	R	R
JTAG TAP Reset/other instruction	R	R	R	R	R	R	R	R	R	R	R	R

**Note to Table 8-17:**

(1) "R" indicates that the instruction must be executed before the next instruction, "O" indicates the optional instruction, "Rc" indicates the recommended instruction, and "NA" indicates that the instruction is not allowed in this mode.

In the AS or AP configuration scheme, the ACTIVE\_DISENGAGE instruction puts the active configuration controller into idle state. If a successful JTAG programming is executed, the active controller is automatically re-engaged after user mode is reached through JTAG programming. This causes the active controller to transition to their respective user mode states.

If JTAG programming fails to get the Cyclone IV device to enter user mode and re-engage active programming, there are available methods to achieve this:

- In AS configuration scheme, you can re-engage the AS controller by moving the JTAG TAP controller to the reset state or by issuing the ACTIVE\_ENGAGE instruction.

- In AP configuration scheme, the only way to re-engage the AP controller is to issue the `ACTIVE_ENGAGE` instruction. In this case, asserting the `nCONFIG` pin does not re-engage either active controller.

### ACTIVE\_ENGAGE

The `ACTIVE_ENGAGE` instruction allows you to re-engage a disengaged active controller. You can issue this instruction any time during configuration or user mode to re-engage an already disengaged active controller, as well as trigger reconfiguration of the Cyclone IV device in the active configuration scheme.

The `ACTIVE_ENGAGE` instruction functions as the `PULSE_NCONFIG` instruction when the device is in the PS or FPP configuration schemes. The `nCONFIG` pin is disabled when the `ACTIVE_ENGAGE` instruction is issued.



Altera does not recommend using the `ACTIVE_ENGAGE` instruction, but it is provided as a fail-safe instruction for re-engaging the active configuration controller (AS and AP).

### Overriding the Internal Oscillator

This feature allows you to override the internal oscillator during the active configuration scheme. The AS and AP configuration controllers use the internal oscillator as the clock source. You can change the clock source to `CLKUSR` through the JTAG instruction.

The `EN_ACTIVE_CLK` and `DIS_ACTIVE_CLK` JTAG instructions toggle on or off whether or not the active clock is sourced from the `CLKUSR` pin or the internal configuration oscillator. To source the active clock from the `CLKUSR` pin, issue the `EN_ACTIVE_CLK` instruction. This causes the `CLKUSR` pin to become the active clock source. When using the `EN_ACTIVE_CLK` instruction, you must enable the internal oscillator for the clock change to occur. By default, the configuration oscillator is disabled after configuration and initialization is complete as well as the device has entered user mode.

However, the internal oscillator is enabled in user mode by any of the following conditions:

- A reconfiguration event (for example, driving the `nCONFIG` pin to go low)
- Remote update is enabled
- Error detection is enabled



When using the `EN_ACTIVE_CLK` and `DIS_ACTIVE_CLK` JTAG instructions to override the internal oscillator, you must clock the `CLKUSR` pin at two times the expected `DCLK` frequency. The `CLKUSR` pin allows a maximum frequency of 40 MHz (40 MHz `DCLK`).

Normally, a test instrument uses the `CLKUSR` pin when it wants to drive its own clock to control the AS state machine.

To revert the clock source back to the configuration oscillator, issue the `DIS_ACTIVE_CLK` instruction. After you issue the `DIS_ACTIVE_CLK` instruction, you must continue to clock the `CLKUSR` pin for 10 clock cycles. Otherwise, even toggling the `nCONFIG` pin does not revert the clock source and reconfiguration does not occur. A POR reverts the clock source back to the configuration oscillator. Toggling the `nCONFIG` pin or driving the JTAG state machine to reset state does not revert the clock source.

### **EN\_ACTIVE\_CLK**

The `EN_ACTIVE_CLK` instruction causes the `CLKUSR` pin signal to replace the internal oscillator as the clock source. When using the `EN_ACTIVE_CLK` instruction, you must enable the internal oscillator for the clock change to occur. After this instruction is issued, other JTAG instructions can be issued while the `CLKUSR` pin signal remains as the clock source. The clock source is only reverted back to the internal oscillator by issuing the `DIS_ACTIVE_CLK` instruction or a POR.

### **DIS\_ACTIVE\_CLK**

The `DIS_ACTIVE_CLK` instruction breaks the `CLKUSR` enable latch set by the `EN_ACTIVE_CLK` instruction and causes the clock source to revert back to the internal oscillator. After the `DIS_ACTIVE_CLK` instruction is issued, you must continue to clock the `CLKUSR` pin for 10 clock cycles.

### **Changing the Start Boot Address of the AP Flash**

In the AP configuration scheme (for Cyclone IV E devices only), you can change the default configuration boot address of the parallel flash memory to any desired address using the `APFC_BOOT_ADDR` JTAG instruction.

### **APFC\_BOOT\_ADDR**

The `APFC_BOOT_ADDR` instruction is for Cyclone IV E devices only and allows you to define a start boot address for the parallel flash memory in the AP configuration scheme.

This instruction shifts in a start boot address for the AP flash. When this instruction becomes the active instruction, the `TDI` and `TDO` pins are connected through a 22-bit active boot address shift register. The shifted-in boot address bits get loaded into the 22-bit AP boot address update register, which feeds into the AP controller. The content of the AP boot address update register can be captured and shifted-out of the active boot address shift register from `TDO`.

The boot address in the boot address shift register and update register are shifted to the right (in the LSB direction) by two bits versus the intended boot address. The reason for this is that the two LSB of the address are not accessible. When this boot address is fed into the AP controller, two 0s are attached in the end as LSB, thereby pushing the shifted-in boot address to the left by two bits, which become the actual AP boot address the AP controller gets.

If you have enabled the remote update feature, the `APFC_BOOT_ADDR` instruction sets the boot address for the factory configuration only.



The `APFC_BOOT_ADDR` instruction is retained after reconfiguration while the system board is still powered on. However, you must reprogram the instruction whenever you restart the system board.

## Device Configuration Pins

Table 8-18 through Table 8-21 describe the connections and functionality of all the configuration related pins on Cyclone IV devices. Table 8-18 and Table 8-19 list the device pin configuration for the Cyclone IV GX and Cyclone IV E, respectively.

**Table 8-18. Configuration Pin Summary for Cyclone IV GX Devices**

Bank	Description	Input/Output	Dedicated	Powered By	Configuration Mode
8	Data[4:2]	Input	—	V <sub>CCIO</sub>	FPP
3	Data[7:5]	Input	—	V <sub>CCIO</sub>	FPP
9	nCSO <sup>(2)</sup>	Output	—	V <sub>CCIO</sub>	AS
3	CRC_ERROR	Output	—	V <sub>CCIO</sub> /Pull-up <sup>(1)</sup>	Optional, all modes
9	DATA [0] <sup>(2)</sup>	Input	Yes	V <sub>CCIO</sub>	PS, FPP, AS
9	DATA [1] /ASDO <sup>(2)</sup>	Input	—	V <sub>CCIO</sub>	FPP
		Output		V <sub>CCIO</sub>	AS
3	INIT_DONE	Output	—	Pull-up	Optional, all modes
3	nSTATUS	Bidirectional	Yes	Pull-up	All modes
9	nCE	Input	Yes	V <sub>CCIO</sub>	All modes
9	DCLK <sup>(2)</sup>	Input	Yes	V <sub>CCIO</sub>	PS, FPP
		Output		V <sub>CCIO</sub>	AS
3	CONF_DONE	Bidirectional	Yes	Pull-up	All modes
9	TDI	Input	Yes	V <sub>CCIO</sub>	JTAG
9	TMS	Input	Yes	V <sub>CCIO</sub>	JTAG
9	TCK	Input	Yes	V <sub>CCIO</sub>	JTAG
9	nCONFIG	Input	Yes	V <sub>CCIO</sub>	All modes
8	CLKUSR	Input	—	V <sub>CCIO</sub>	Optional
3	nCEO	Output	—	V <sub>CCIO</sub>	Optional, all modes
3	MSEL	Input	Yes	V <sub>CCINT</sub>	All modes
9	TDO	Output	Yes	V <sub>CCIO</sub>	JTAG
6	DEV_OE	Input	—	V <sub>CCIO</sub>	Optional
6	DEV_CLRn	Input	—	V <sub>CCIO</sub>	Optional

**Notes to Table 8-18:**

- (1) The CRC\_ERROR pin is a dedicated open-drain output or an optional user I/O pin. Active high signal indicates that the error detection circuit has detected errors in the configuration SRAM bits. This pin is optional and is used when the CRC error detection circuit is enabled in the Quartus II software from the **Error Detection CRC** tab of the **Device and Pin Options** dialog box. When using this pin, connect it to an external 10-k $\Omega$  pull-up resistor to an acceptable voltage that satisfies the input voltage of the receiving device.
- (2) To tri-state AS configuration pins in the AS configuration scheme, turn on the **Enable input tri-state on active configuration pins in user mode** option from the **Device and Pin Options** dialog box. This tri-states DCLK, nCSO, Data [0], and Data [1] /ASDO pins. Dual-purpose pins settings for these pins are ignored. To set these pins to different settings, turn off the **Enable input tri-state on active configuration pins in user mode** option and set the desired setting from the Dual-purpose Pins Setting menu.

**Table 8-19. Configuration Pin Summary for Cyclone IV E Devices (Part 1 of 3)**

Bank	Description	Input/Output	Dedicated	Powered By	Configuration Mode
1	nCSO <sup>(1)</sup> FLASH_nCE <sup>(2)</sup>	Output	—	V <sub>CCIO</sub>	AS, AP
6	CRC_ERROR <sup>(3)</sup>	Output	—	V <sub>CCIO</sub> /Pull-up <sup>(4)</sup>	Optional, all modes

**Table 8-19. Configuration Pin Summary for Cyclone IV E Devices (Part 2 of 3)**

Bank	Description	Input/Output	Dedicated	Powered By	Configuration Mode
1	DATA [0] (1), (2)	Input	—	V <sub>CCIO</sub>	PS, FPP, AS
		Bidirectional		V <sub>CCIO</sub>	AP
1	DATA [1] (2) /ASDO (1)	Input	—	V <sub>CCIO</sub>	FPP
		Output		V <sub>CCIO</sub>	AS
		Bidirectional		V <sub>CCIO</sub>	AP
8	DATA [7..2] (2)	Input	—	V <sub>CCIO</sub>	FPP
		Bidirectional		V <sub>CCIO</sub>	AP
8	DATA [15..8] (2)	Bidirectional	—	V <sub>CCIO</sub>	AP
6	INIT_DONE	Output	—	Pull-up	Optional, all modes
1	nSTATUS	Bidirectional	Yes	Pull-up	All modes
1	nCE	Input	Yes	V <sub>CCIO</sub>	All modes
1	DCLK (1), (2)	Input	Yes	V <sub>CCIO</sub>	PS, FPP
		Output	—	V <sub>CCIO</sub>	AS, AP
6	CONF_DONE	Bidirectional	Yes	Pull-up	All modes
1	TDI	Input	Yes	V <sub>CCIO</sub>	JTAG
1	TMS	Input	Yes	V <sub>CCIO</sub>	JTAG
1	TCK	Input	Yes	V <sub>CCIO</sub>	JTAG
1	nCONFIG	Input	Yes	V <sub>CCIO</sub>	All modes
6	CLKUSR	Input	—	V <sub>CCIO</sub>	Optional
6	nCEO	Output	—	V <sub>CCIO</sub>	Optional, all modes
6	MSEL []	Input	Yes	V <sub>CCINT</sub>	All modes
1	TDO	Output	Yes	V <sub>CCIO</sub>	JTAG
7	PADD [14..0]	Output	—	V <sub>CCIO</sub>	AP
8	PADD [19..15]	Output	—	V <sub>CCIO</sub>	AP
6	PADD [23..20]	Output	—	V <sub>CCIO</sub>	AP
1	nRESET	Output	—	V <sub>CCIO</sub>	AP
6	nAVD	Output	—	V <sub>CCIO</sub>	AP
6	nOE	Output	—	V <sub>CCIO</sub>	AP
6	nWE	Output	—	V <sub>CCIO</sub>	AP
5	DEV_OE	Input	—	V <sub>CCIO</sub>	Optional, AP

**Table 8-19. Configuration Pin Summary for Cyclone IV E Devices (Part 3 of 3)**

Bank	Description	Input/Output	Dedicated	Powered By	Configuration Mode
5	DEV_CLRn	Input	—	V <sub>CCIO</sub>	Optional, AP

**Notes to Table 8-19:**

- (1) To tri-state AS configuration pins in the AS configuration scheme, turn-on the **Enable input tri-state on active configuration pins in user mode** option from the **Device and Pin Options** dialog box. This tri-states DCLK, nCS0, Data[0], and Data[1]/ASDO pins. Dual-purpose pins settings for these pins are ignored. To set these pins to different settings, turn off the **Enable input tri-state on active configuration pins in user mode** option and set the desired setting from the Dual-purpose Pins Setting menu.
- (2) To tri-state AP configuration pins in the AP configuration scheme, turn-on the **Enable input tri-state on active configuration pins in user mode** option from the **Device and Pin Options** dialog box. This tri-states DCLK, Data[0..15], FLASH\_nCE, and other AP pins. Dual-purpose pins settings for these pins are ignored. To set these pins to different settings, turn off the **Enable input tri-state on active configuration pins in user mode** option and set the desired setting from the Dual-purpose Pins Setting menu.
- (3) The CRC\_ERROR pin is not available in Cyclone IV E devices with 1.0-V core voltage.
- (4) The CRC\_ERROR pin is a dedicated open-drain output or an optional user I/O pin. Active high signal indicates that the error detection circuit has detected errors in the configuration SRAM bits. This pin is optional and is used when the CRC error detection circuit is enabled in the Quartus II software from the **Error Detection CRC** tab of the **Device and Pin Options** dialog box. When using this pin, connect it to an external 10-k $\Omega$  pull-up resistor to an acceptable voltage that satisfies the input voltage of the receiving device.

Table 8-20 describes the dedicated configuration pins. You must properly connect these pins on your board for successful configuration. You may not need some of these pins for your configuration schemes.

**Table 8-20. Dedicated Configuration Pins on the Cyclone IV Device (Part 1 of 4)**

Pin Name	User Mode	Configuration Scheme	Pin Type	Description
MSEL	N/A	All	Input	Configuration input that sets the Cyclone IV device configuration scheme. You must hardwire these pins to V <sub>CCA</sub> or GND. The MSEL pins have internal 9-k $\Omega$ pull-down resistors that are always active.
nCONFIG	N/A	All	Input	Configuration control input. Pulling this pin low with external circuitry during user mode causes the Cyclone IV device to lose its configuration data, enter a reset state, and tri-state all I/O pins. Returning this pin to a logic-high level starts a reconfiguration.
nSTATUS	N/A	All	Bidirectional open-drain	<p>The Cyclone IV device drives nSTATUS low immediately after power-up and releases it after the POR time.</p> <ul style="list-style-type: none"> <li>■ Status output—if an error occurs during configuration, nSTATUS is pulled low by the target device.</li> <li>■ Status input—if an external source (for example, another Cyclone IV device) drives the nSTATUS pin low during configuration or initialization, the target device enters an error state.</li> </ul> <p>Driving nSTATUS low after configuration and initialization does not affect the configured device. If you use a configuration device, driving nSTATUS low causes the configuration device to attempt to configure the device, but because the device ignores transitions on nSTATUS in user mode, the device does not reconfigure. To start a reconfiguration, you must pull nCONFIG low.</p>

**Table 8-20. Dedicated Configuration Pins on the Cyclone IV Device (Part 2 of 4)**

Pin Name	User Mode	Configuration Scheme	Pin Type	Description
CONF_DONE	N/A	All	Bidirectional open-drain	<ul style="list-style-type: none"> <li>■ Status output—the target Cyclone IV device drives the CONF_DONE pin low before and during configuration. After all the configuration data is received without error and the initialization cycle starts, the target device releases CONF_DONE.</li> <li>■ Status input—after all the data is received and CONF_DONE goes high, the target device initializes and enters user mode. The CONF_DONE pin must have an external 10-kΩ pull-up resistor in order for the device to initialize.</li> </ul> <p>Driving CONF_DONE low after configuration and initialization does not affect the configured device. Do not connect bus holds or ADC to CONF_DONE pin.</p>
nCE	N/A	All	Input	Active-low chip enable. The nCE pin activates the Cyclone IV device with a low signal to allow configuration. You must hold nCE pin low during configuration, initialization, and user-mode. In a single-device configuration, you must tie the nCE pin low. In a multi-device configuration, nCE of the first device is tied low while its nCEO pin is connected to nCE of the next device in the chain. You must hold the nCE pin low for successful JTAG programming of the device.
nCEO	N/A if option is on. I/O if option is off.	All	Output open-drain	<p>Output that drives low when configuration is complete. In a single-device configuration, you can leave this pin floating or use it as a user I/O pin after configuration. In a multi-device configuration, this pin feeds the nCE pin of the next device. The nCEO of the last device in the chain is left floating or used as a user I/O pin after configuration.</p> <p>If you use the nCEO pin to feed the nCE pin of the next device, use an external 10-kΩ pull-up resistor to pull the nCEO pin high to the V<sub>CCIO</sub> voltage of its I/O bank to help the internal weak pull-up resistor.</p> <p>If you use the nCEO pin as a user I/O pin after configuration, set the state of the pin on the <b>Dual-Purpose Pin</b> settings.</p>
nCSO, FLASH_nCE (1)	I/O	AS, AP (2)	Output	<p>Output control signal from the Cyclone IV device to the serial configuration device in AS mode that enables the configuration device. This pin functions as nCSO in AS mode and FLASH_nCE in AP mode.</p> <p>Output control signal from the Cyclone IV device to the parallel flash in AP mode that enables the flash. Connects to the CE# pin on the Micron P30 or P33 flash. (2)</p> <p>This pin has an internal pull-up resistor that is always active.</p>

Table 8-20. Dedicated Configuration Pins on the Cyclone IV Device (Part 3 of 4)

Pin Name	User Mode	Configuration Scheme	Pin Type	Description
DCLK <sup>(1)</sup>	N/A	PS, FPP, AS, AP <sup>(2)</sup>	Input (PS, FPP) <sup>(2)</sup>	In PS and FPP configuration, DCLK is the clock input used to clock data from an external source into the target Cyclone IV device. Data is latched into the device on the rising edge of DCLK.
	I/O		Output (AS, AP)	<p>In AS mode, DCLK is an output from the Cyclone IV device that provides timing for the configuration interface. It has an internal pull-up resistor (typically 25 kΩ) that is always active.</p> <p>In AP mode, DCLK is an output from the Cyclone IV E device that provides timing for the configuration interface. <sup>(2)</sup></p> <p>In AS or AP configuration schemes, this pin is driven into an inactive state after configuration completes. Alternatively, in active schemes, you can use this pin as a user I/O during user mode. In PS or FPP schemes that use a control host, you must drive DCLK either high or low, whichever is more convenient. In passive schemes, you cannot use DCLK as a user I/O in user mode. Toggling this pin after configuration does not affect the configured device.</p>
DATA [0] <sup>(1)</sup>	I/O	PS, FPP, AS, AP <sup>(2)</sup>	Input (PS, FPP, AS). Bidirectional (AP) <sup>(2)</sup>	<p>Data input. In serial configuration modes, bit-wide configuration data is presented to the target Cyclone IV device on the DATA [0] pin.</p> <p>In AS mode, DATA [0] has an internal pull-up resistor that is always active. After AS configuration, DATA [0] is a dedicated input pin with optional user control.</p> <p>After PS or FPP configuration, DATA [0] is available as a user I/O pin. The state of this pin depends on the <b>Dual-Purpose Pin</b> settings.</p> <p>After AP configuration, DATA [0] is a dedicated bidirectional pin with optional user control. <sup>(2)</sup></p>
DATA [1] / ASDO <sup>(1)</sup>	I/O	FPP, AS, AP <sup>(2)</sup>	Input (FPP). Output (AS). Bidirectional (AP) <sup>(2)</sup>	<p>The DATA [1] pin functions as the ASDO pin in AS mode. Data input in non-AS mode. Control signal from the Cyclone IV device to the serial configuration device in AS mode used to read out configuration data.</p> <p>In AS mode, DATA [1] has an internal pull-up resistor that is always active. After AS configuration, DATA [1] is a dedicated output pin with optional user control.</p> <p>In a PS configuration scheme, DATA [1] functions as a user I/O pin during configuration, which means it is tri-stated.</p> <p>After FPP configuration, DATA [1] is available as a user I/O pin and the state of this pin depends on the <b>Dual-Purpose Pin</b> settings.</p> <p>In an AP configuration scheme, for Cyclone IV E devices only, the byte-wide or word-wide configuration data is presented to the target Cyclone IV E device on DATA [7 . . 0] or DATA [15 . . 0], respectively. After AP configuration, DATA [1] is a dedicated bidirectional pin with optional user control. <sup>(2)</sup></p>

**Table 8-20. Dedicated Configuration Pins on the Cyclone IV Device (Part 4 of 4)**

Pin Name	User Mode	Configuration Scheme	Pin Type	Description
DATA [7..2]	I/O	FPP, AP <sup>(2)</sup>	Inputs (FPP). Bidirectional (AP) <sup>(2)</sup>	In an AS or PS configuration scheme, DATA [7..2] function as user I/O pins during configuration, which means they are tri-stated.  After FPP configuration, DATA [7..2] are available as user I/O pins and the state of these pin depends on the <b>Dual-Purpose Pin</b> settings.  In an AP configuration scheme, for Cyclone IV E devices only, the byte-wide or word-wide configuration data is presented to the target Cyclone IV E device on DATA [7..0] or DATA [15..0], respectively. After AP configuration, DATA [7..2] are dedicated bidirectional pins with optional user control. <sup>(2)</sup>
DATA [15..8]	I/O	AP <sup>(2)</sup>	Bidirectional	Data inputs. Word-wide configuration data is presented to the target Cyclone IV E device on DATA [15..0].  In a PS, FPP, or AS configuration scheme, DATA [15:8] function as user I/O pins during configuration, which means they are tri stated.  After AP configuration, DATA [15:8] are dedicated bidirectional pins with optional user control.
PADD [23..0]	I/O	AP <sup>(2)</sup>	Output	In AP mode, it is a 24-bit address bus from the Cyclone IV E device to the parallel flash. Connects to the A[24:1] bus on the Micron P30 or P33 flash.
nRESET	I/O	AP <sup>(2)</sup>	Output	Active-low reset output. Driving the nRESET pin low resets the parallel flash. Connects to the RST# pin on the Micron P30 or P33 flash.
nAVD	I/O	AP <sup>(2)</sup>	Output	Active-low address valid output. Driving the nAVD pin low during read or write operation indicates to the parallel flash that a valid address is present on the PADD [23..0] address bus. Connects to the ADV# pin on the Micron P30 or P33 flash.
nOE	I/O	AP <sup>(2)</sup>	Output	Active-low output enable to the parallel flash. During the read operation, driving the nOE pin low enables the parallel flash outputs (DATA [15..0]). Connects to the OE# pin on the Micron P30 or P33 flash.
nWE	I/O	AP <sup>(2)</sup>	Output	Active-low write enable to the parallel flash. During the write operation, driving the nWE pin low indicates to the parallel flash that data on the DATA [15..0] bus is valid. Connects to the WE# pin on the Micron P30 or P33 flash.

**Note to Table 8-20:**

- (1) If you are accessing the EPCS device with the ALTASML\_PARALLEL megafunction or your own user logic in user mode, in the **Device and Pin Options** window of the Quartus II software, in the **Dual-Purpose Pins** category, select **Use as regular I/O** for this pin.
- (2) The AP configuration scheme is for Cyclone IV E devices only.

Table 8–21 lists the optional configuration pins. If you do not enable these optional configuration pins in the Quartus II software, they are available as general-purpose user I/O pins. Therefore, during configuration, these pins function as user I/O pins and are tri-stated with weak pull-up resistors.

**Table 8–21. Optional Configuration Pins**

Pin Name	User Mode	Pin Type	Description
CLKUSR	N/A if option is on. I/O if option is off.	Input	Optional user-supplied clock input synchronizes the initialization of one or more devices. This pin is enabled by turning on the <b>Enable user-supplied start-up clock (CLKUSR)</b> option in the Quartus II software.  In AS configuration for Cyclone IV GX devices, you can use this pin as an external clock source to generate the <code>DCLK</code> by changing the clock source option in the Quartus II software in the <b>Configuration</b> tab of the <b>Device and Pin Options</b> dialog box.
INIT_DONE	N/A if option is on. I/O if option is off.	Output open-drain	Status pin is used to indicate when the device has initialized and is in user-mode. When <code>nCONFIG</code> is low, the <code>INIT_DONE</code> pin is tri-stated and pulled high due to an external 10-k $\Omega$ pull-up resistor during the beginning of configuration. After the option bit to enable <code>INIT_DONE</code> is programmed into the device (during the first frame of configuration data), the <code>INIT_DONE</code> pin goes low. When initialization is complete, the <code>INIT_DONE</code> pin is released and pulled high and the device enters user mode. Thus, the monitoring circuitry must be able to detect a low-to-high transition. This pin is enabled by turning on the <b>Enable INIT_DONE output</b> option in the Quartus II software.  The functionality of this pin changes if the <b>Enable OCT_DONE</b> option is enabled in the Quartus II software. This option controls whether the <code>INIT_DONE</code> signal is gated by the <code>OCT_DONE</code> signal, which indicates the power-up on-chip termination (OCT) calibration is complete. If this option is turned off, the <code>INIT_DONE</code> signal is not gated by the <code>OCT_DONE</code> signal.
DEV_OE	N/A if option is on. I/O if option is off.	Input	Optional pin that allows you to override all tri-states on the device. When this pin is driven low, all I/O pins are tri-stated; when this pin is driven high, all I/O pins behave as programmed. This pin is enabled by turning on the <b>Enable device-wide output enable (DEV_OE)</b> option in the Quartus II software.
DEV_CLRn	N/A if option is on. I/O if option is off.	Input	Optional pin that allows you to override all clears on all device registers. When this pin is driven low, all registers are cleared; when this pin is driven high, all registers behave as programmed. You can enable this pin by turning on the <b>Enable device-wide reset (DEV_CLRn)</b> option in the Quartus II software.

## Remote System Upgrade

Cyclone IV devices support remote system upgrade in AS and AP configuration schemes. You can also implement remote system upgrade with advanced Cyclone IV features such as real-time decompression of configuration data in the AS configuration scheme.

 Remote system upgrade is not supported in a multi-device configuration chain for any configuration scheme.

### Functional Description

The dedicated remote system upgrade circuitry in Cyclone IV devices manages remote configuration and provides error detection, recovery, and status information. A Nios® II processor or a user logic implemented in the Cyclone IV device logic array provides access to the remote configuration data source and an interface to the configuration memory.

 Configuration memory refers to serial configuration devices (EPCS) or supported parallel flash memory, depending on the configuration scheme that is used.

The remote system upgrade process of the Cyclone IV device consists of the following steps:

1. A Nios II processor (or user logic) implemented in the Cyclone IV device logic array receives new configuration data from a remote location. The connection to the remote source is a communication protocol, such as the transmission control protocol/Internet protocol (TCP/IP), peripheral component interconnect (PCI), user datagram protocol (UDP), universal asynchronous receiver/transmitter (UART), or a proprietary interface.
2. The Nios II processor (or user logic) writes this new configuration data into a configuration memory.
3. The Nios II processor (or user logic) starts a reconfiguration cycle with the new or updated configuration data.
4. The dedicated remote system upgrade circuitry detects and recovers from any error that might occur during or after the reconfiguration cycle and provides error status information to the user design.

Figure 8-30 shows the steps required for performing remote configuration updates (the numbers in Figure 8-30 coincide with steps 1-3).

**Figure 8-30. Functional Diagram of Cyclone IV Device Remote System Upgrade**

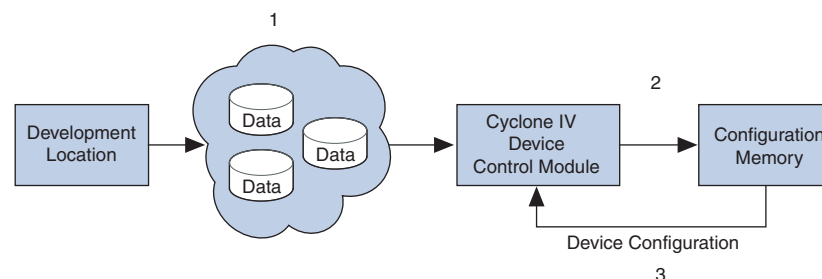
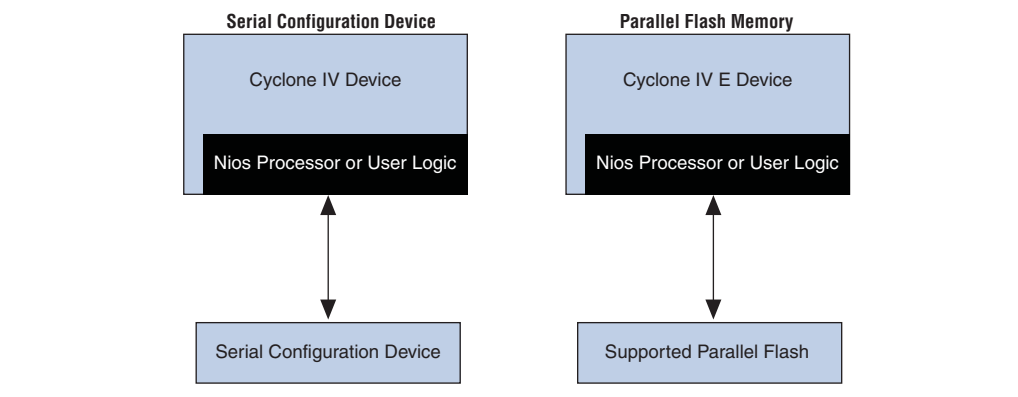

Figure 8-31 shows the block diagrams to implement remote system upgrade in Cyclone IV devices.

**Figure 8-31. Remote System Upgrade Block Diagrams for AS and AP Configuration Schemes**



The MSEL pin setting in the remote system upgrade mode is the same as the standard configuration mode. Standard configuration mode refers to normal Cyclone IV device configuration mode with no support for remote system upgrades (the remote system upgrade circuitry is disabled). When using remote system upgrade in Cyclone IV devices, you must enable the remote update mode option setting in the Quartus II software.

## Enabling Remote Update

You can enable or disable remote update for Cyclone IV devices in the Quartus II software before design compilation (in the Compiler Settings menu). To enable remote update in the compiler settings of the project, perform the following steps:

1. On the Assignments menu, click **Device**. The **Settings** dialog box appears.
2. Click **Device and Pin Options**. The **Device and Pin Options** dialog box appears.
3. Click the **Configuration** tab.
4. From the **Configuration Mode** list, select **Remote**.
5. Click **OK**.
6. In the **Settings** dialog box, click **OK**.

## Configuration Image Types

When using remote system upgrade, Cyclone IV device configuration bitstreams are classified as factory configuration images or application configuration images. An image, also referred to as a configuration, is a design loaded into the device that performs certain user-defined functions. Each device in your system requires one factory image or with addition of one or more application images. The factory image is a user-defined fall-back or safe configuration and is responsible for administering remote updates with the dedicated circuitry. Application images implement user-defined functionality in the target Cyclone IV device. You can include the default application image functionality in the factory image.

## Remote System Upgrade Mode

In remote update mode, Cyclone IV devices load the factory configuration image after power up. The user-defined factory configuration determines the application configuration to be loaded and triggers a reconfiguration cycle. The factory configuration can also contain application logic.

When used with configuration memory, the remote update mode allows an application configuration to start at any flash sector boundary. Additionally, the remote update mode features a user watchdog timer that can detect functional errors in an application configuration.

### Remote Update Mode

In AS configuration scheme, when a Cyclone IV device is first powered up in remote update, it loads the factory configuration located at address `boot_address[23:0] = 24b'0`. Altera recommends storing the factory configuration image for your system at boot address `24b'0`, which corresponds to the start address location `0x000000` in the serial configuration device. A factory configuration image is a bitstream for the Cyclone IV device in your system that is programmed during production and is the fall-back image when an error occurs. This image is stored in non-volatile memory and is never updated or modified using remote access.

When you use the AP configuration in Cyclone IV E devices, the Cyclone IV E device loads the default factory configuration located at the following address after device power-up in remote update mode:

```
boot_address[23:0] = 24'h010000 = 24'b1 0000 0000 0000 0000.
```

You can change the default factory configuration address to any desired address using the `APFC_BOOT_ADDR JTAG` instruction. The factory configuration image is stored in non-volatile memory and is never updated or modified using remote access. This corresponds to the default start address location `0x010000` represented in 16-bit word addressing (or the updated address if the default address is changed) in the supported parallel flash memory. For more information about the application of the `APFC_BOOT_ADDR JTAG` instruction in AP configuration scheme, refer to the [“JTAG Instructions” on page 8-57](#).

The factory configuration image is user-designed and contains soft logic (Nios II processor or state machine and the remote communication interface) to:

- Process any errors based on status information from the dedicated remote system upgrade circuitry
- Communicate with the remote host and receive new application configurations and store the new configuration data in the local non-volatile memory device
- Determine the application configuration to be loaded into the Cyclone IV device
- Enable or disable the user watchdog timer and load its time-out value (optional)
- Instruct the dedicated remote system upgrade circuitry to start a reconfiguration cycle

Figure 8-32 shows the transitions between the factory configuration and application configuration in remote update mode.

**Figure 8-32. Transitions Between Configurations in Remote Update Mode**

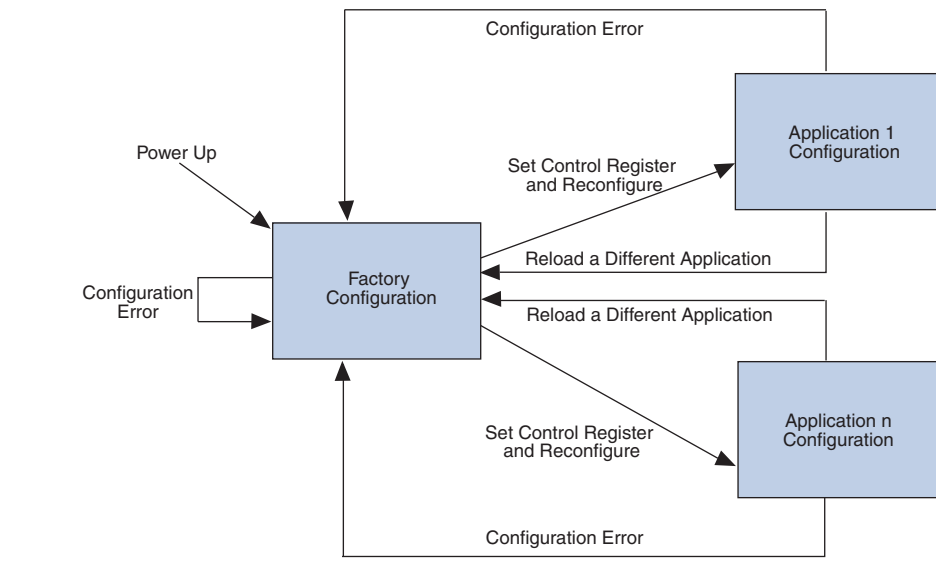

After power up or a configuration error, the factory configuration logic writes the remote system upgrade control register to specify the address of the application configuration to be loaded. The factory configuration also specifies whether or not to enable the user watchdog timer for the application configuration and, if enabled, specifies the timer setting.



Only valid application configurations designed for remote update mode include the logic to reset the timer in user mode. For more information about the user watchdog timer, refer to the “[User Watchdog Timer](#)” on page 8-79.

If there is an error while loading the application configuration, the remote system upgrade status register is written by the dedicated remote system upgrade circuitry of the Cyclone IV device to specify the cause of the reconfiguration.

The following actions cause the remote system upgrade status register to be written:

- nSTATUS driven low externally
- Internal cyclical redundancy check (CRC) error
- User watchdog timer time-out
- A configuration reset (logic array nCONFIG signal or external nCONFIG pin assertion)

The Cyclone IV device automatically loads the factory configuration when an error occurs. This user-designed factory configuration reads the remote system upgrade status register to determine the reason for reconfiguration. Then the factory configuration takes the appropriate error recovery steps and writes to the remote system upgrade control register to determine the next application configuration to be loaded.

When Cyclone IV devices successfully load the application configuration, they enter user mode. In user mode, the soft logic (the Nios II processor or state machine and the remote communication interface) assists the Cyclone IV device in determining when a remote system update is arriving. When a remote system update arrives, the soft logic receives the incoming data, writes it to the configuration memory device and triggers the device to load the factory configuration. The factory configuration reads the remote system upgrade status register, determines the valid application configuration to load, writes the remote system upgrade control register accordingly, and starts system reconfiguration.

## Dedicated Remote System Upgrade Circuitry

This section describes the implementation of the Cyclone IV device remote system upgrade dedicated circuitry. The remote system upgrade circuitry is implemented in hard logic. This dedicated circuitry interfaces with the user-defined factory application configurations implemented in the Cyclone IV device logic array to provide the complete remote configuration solution. The remote system upgrade circuitry contains the remote system upgrade registers, a watchdog timer, and state machines that control those components. [Figure 8-33](#) shows the data path of the remote system upgrade block.

**Figure 8-33. Remote System Upgrade Circuit Data Path <sup>(1)</sup>**

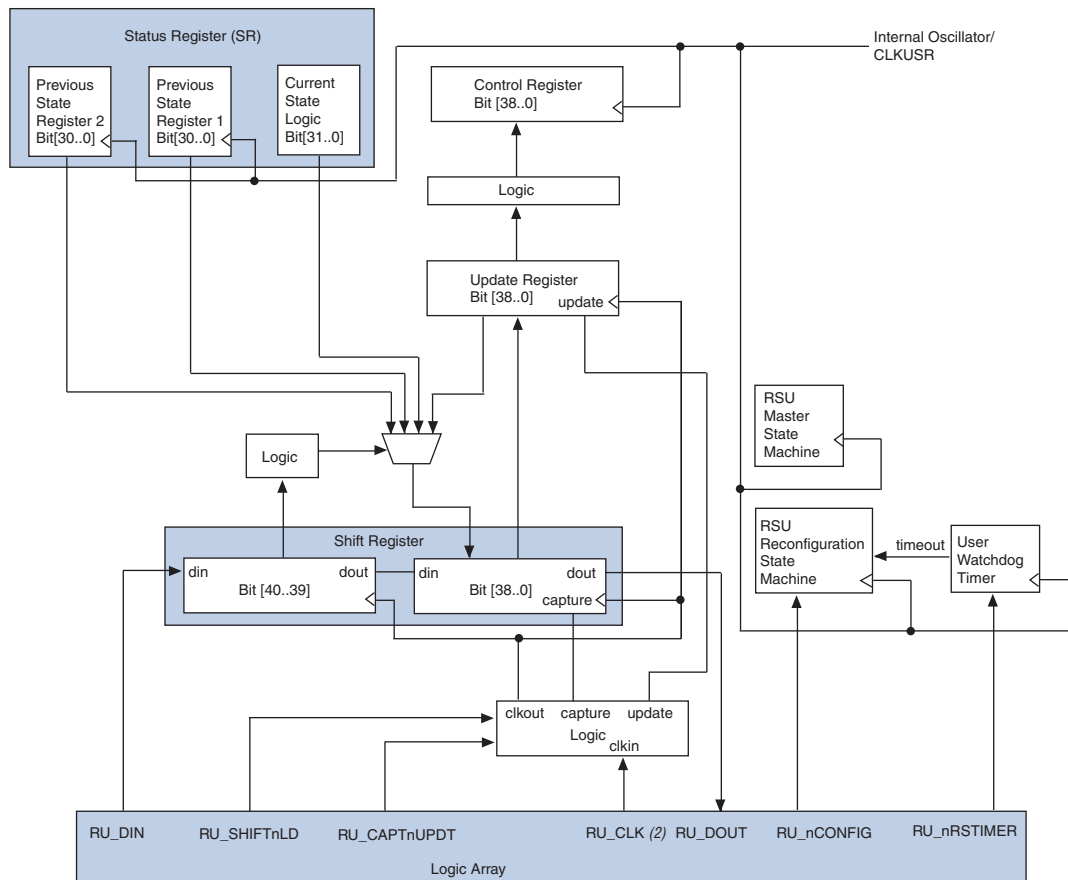

### Notes to Figure 8-33:

- (1) The RU\_DOUT, RU\_SHIFTnLD, RU\_CAPTnUPDT, RU\_CLK, RU\_DIN, RU\_nCONFIG, and RU\_nRSTIMER signals are internally controlled by the ALTREMOTE\_UPDATE megafunction.
- (2) The RU\_CLK refers to the ALTREMOTE\_UPDATE megafunction block "clock" input. For more information, refer to the [Remote Update Circuitry \(ALTREMOTE\\_UPDATE\) Megafunction User Guide](#).

## Remote System Upgrade Registers

The remote system upgrade block contains a series of registers that stores the configuration addresses, watchdog timer settings, and status information. Table 8-22 lists these registers.

**Table 8-22. Remote System Upgrade Registers**

Register	Description
Shift register	This register is accessible by the logic array and allows the update, status, and control registers to be written and sampled by user logic. Write access is enabled in remote update mode for factory configurations to allow writing to the update register. Write access is disabled for all application configurations in remote update mode.
Control register	This register contains the current configuration address, the user watchdog timer settings, one option bit for checking early CONF_DONE, and one option bit for selecting the internal oscillator as the startup state machine clock. During a read operation in an application configuration, this register is read into the shift register. When a reconfiguration cycle is started, the contents of the update register are written into the control register.
Update register	This register contains data similar to that in the control register. However, it can only be updated by the factory configuration by shifting data into the shift register and issuing an update operation. When a reconfiguration cycle is triggered by the factory configuration, the control register is updated with the contents of the update register. During a read in a factory configuration, this register is read into the shift register.
Status register	This register is written by the remote system upgrade circuitry on every reconfiguration to record the cause of the reconfiguration. This information is used by the factory configuration to determine the appropriate action following a reconfiguration. During a capture cycle, this register is read into the shift register.

The control and status registers of the remote system upgrade are clocked by the 10-MHz internal oscillator (the same oscillator that controls the user watchdog timer) or the CLKUSR. However, the shift and update registers of the remote system upgrade are clocked by the maximum frequency of 40-MHz user clock input (RU\_CLK). There is no minimum frequency for RU\_CLK.

### Remote System Upgrade Control Register

The remote system upgrade control register stores the application configuration address, the user watchdog timer settings, and option bits for a application configuration. In remote update mode for the AS configuration scheme, the control register address bits are set to all zeros (24'b0) at power up to load the AS factory configuration. In remote update mode for the AP configuration scheme, the control register address bits are set to 24'h010000 (24'b1 0000 0000 0000 0000) at power up to load the AP default factory configuration. However, for the AP configuration scheme, you can change the default factory configuration address to any desired address using the APFC\_BOOT\_ADDR JTAG instruction. Additionally, a factory configuration in remote update mode has write access to this register.

Figure 8-34 shows the control register bit positions. Table 8-23 defines the control register bit contents. The numbers in Figure 8-34 show the bit position of a setting in a register. For example, bit number 35 is the enable bit for the watchdog timer.

**Figure 8-34. Remote System Upgrade Control Register**

38	37	36	35	34	33	12	11	0
Rsv2	Cd_early	Osc_int	Wd_en	Rsv1	Ru_address[21..0]	Wd_timer[11..0]		

**Table 8-23. Remote System Upgrade Control Register Contents**

Control Register Bit	Value	Definition
Wd_timer[11..0]	12'b000000000000	User watchdog time-out value (most significant 12 bits of 29-bit count value: {Wd_timer[11..0], 17'b1000})
Ru_address[21..0]	22'b0000000000000000000000	Configuration address (most significant 22 bits of 24-bit boot address value: boot_address[23:0] = {Ru_address[21..0], 2'b0})
Rsv1	1'b0	Reserved bit
Wd_en	1'b1	User watchdog timer enable bit
Osc_int (1)	1'b1	Internal oscillator as startup state machine clock enable bit
Cd_early (1)	1'b1	Early CONF_DONE check
Rsv2	1'b1	Reserved bit

**Note to Table 8-23:**

(1) Option bit for the application configuration.

When enabled, the early CONF\_DONE check (Cd\_early) option bit ensures that there is a valid configuration at the boot address specified by the factory configuration and that it is of the proper size. If an invalid configuration is detected or the CONF\_DONE pin is asserted too early, the device resets and then reconfigures the factory configuration image. The internal oscillator (as the startup state machine clock [Osc\_int] option bit) ensures a functional startup clock to eliminate the hanging of startup. When all option bits are turned on, they provide complete coverage for the programming and startup portions of the application configuration. Altera recommends turning on both the Cd\_early and Osc\_int option bits.



The Cd\_early and Osc\_int option bits for the application configuration must be turned on by the factory configuration.

### Remote System Upgrade Status Register

The remote system upgrade status register specifies the reconfiguration trigger condition. The various trigger and error conditions include:

- Cyclical redundancy check (CRC) error during application configuration
- nSTATUS assertion by an external device due to an error
- Cyclone IV device logic array triggers a reconfiguration cycle, possibly after downloading a new application configuration image

- External configuration reset (nCONFIG) assertion
- User watchdog timer time out

Table 8–24 lists the contents of the current state logic in the status register, when the remote system upgrade master state machine is in factory configuration or application configuration accessing the factory information or application information, respectively. The status register bit in Table 8–24 lists the bit positions in a 32-bit logic.

**Table 8–24. Remote System Upgrade Current State Logic Contents In Status Register**

Remote System Upgrade Master State Machine	Status Register Bit	Definition	Description
Factory information (1)	31:30	Master state machine current state	The current state of the remote system upgrade master state machine
	29:24	Reserved bits	Padding bits that are set to all 0's
	23:0	Boot address	The current 24-bit boot address that was used by the configuration scheme as the start address to load the current configuration.
Application information 1 (2)	31:30	Master state machine current state	The current state of the remote system upgrade master state machine
	29	User watchdog timer enable bit	The current state of the user watchdog enable, which is active high
	28:0	User watchdog timer time-out value	The current entire 29-bit watchdog time-out value.
Application information 2 (2)	31:30	Master state machine current state	The current state of the remote system upgrade master state machine
	29:24	Reserved bits	Padding bits that are set to all 0's
	23:0	Boot address	The current 24-bit boot address that was used as the start address to load the current configuration

**Notes to Table 8–24:**

- (1) The remote system upgrade master state machine is in factory configuration.  
 (2) The remote system upgrade master state machine is in application configuration.

The previous two application configurations are available in the previous state registers (previous state register 1 and previous state register 2), but only for debugging purposes.

Table 8–25 lists the contents of previous state register 1 and previous state register 2 in the status register. The status register bit in Table 8–25 shows the bit positions in a 3-bit register. The previous state register 1 and previous state register 2 have the same bit definitions. The previous state register 1 reflects the current application configuration and the previous state register 2 reflects the previous application configuration.

**Table 8–25. Remote System Upgrade Previous State Register 1 and Previous State Register 2 Contents in Status Register**

Status Register Bit	Definition	Description
30	nCONFIG source	One-hot, active-high field that describes the reconfiguration source that caused the Cyclone IV device to leave the previous application configuration. If there is a tie, the higher bit order indicates precedence. For example, if nCONFIG and remote system upgrade nCONFIG reach the reconfiguration state machine at the same time, the nCONFIG precedes the remote system upgrade nCONFIG.
29	CRC error source	
28	nSTATUS source	
27	User watchdog timer source	
26	Remote system upgrade nCONFIG source	
25 : 24	Master state machine current state	The state of the master state machine during reconfiguration causes the Cyclone IV device to leave the previous application configuration.
23 : 0	Boot address	The address used by the configuration scheme to load the previous application configuration.

If a capture is inappropriately done while capturing a previous state before the system has entered remote update application configuration for the first time, a value outputs from the shift register to indicate that the capture is incorrectly called.

### Remote System Upgrade State Machine

The remote system upgrade control and update registers have identical bit definitions, but serve different roles (Table 8–22 on page 8–75). While both registers can only be updated when the device is loaded with a factory configuration image, the update register writes are controlled by the user logic, and the control register writes are controlled by the remote system upgrade state machine.

In factory configurations, the user logic should send the option bits (Cd\_early and Osc\_int), the configuration address, and watchdog timer settings for the next application configuration bit to the update register. When the logic array configuration reset (RU\_nCONFIG) goes high, the remote system upgrade state machine updates the control register with the contents of the update register and starts system reconfiguration from the new application page.



To ensure the successful reconfiguration between the pages, assert the RU\_nCONFIG signal for a minimum of 250 ns. This is equivalent to strobing the reconfig input of the ALTREMOTE\_UPDATE megafunction high for a minimum of 250 ns.

If there is an error or reconfiguration trigger condition, the remote system upgrade state machine directs the system to load a factory or application configuration (based on mode and error condition) by setting the control register accordingly.

Table 8–26 lists the contents of the control register after such an event occurs for all possible error or trigger conditions.

The remote system upgrade status register is updated by the dedicated error monitoring circuitry after an error condition, but before the factory configuration is loaded.

**Table 8-26. Control Register Contents After an Error or Reconfiguration Trigger Condition**

Reconfiguration Error/Trigger	Control Register Setting In Remote Update
nCONFIG reset	All bits are 0
nSTATUS error	All bits are 0
CORE triggered reconfiguration	Update register
CRC error	All bits are 0
Wd time out	All bits are 0

### User Watchdog Timer

The user watchdog timer prevents a faulty application configuration from indefinitely stalling the device. The system uses the timer to detect functional errors after an application configuration is successfully loaded into the Cyclone IV device.

The user watchdog timer is a counter that counts down from the initial value loaded into the remote system upgrade control register by the factory configuration. The counter is 29 bits wide and has a maximum count value of  $2^{29}$ . When specifying the user watchdog timer value, specify only the most significant 12 bits. The remote system upgrade circuitry appends 17'b1000 to form the 29-bits value for the watchdog timer. The granularity of the timer setting is  $2^{17}$  cycles. The cycle time is based on the frequency of the 10-MHz internal oscillator or CLKUSR (maximum frequency of 40 MHz).

Table 8-27 lists the operating range of the 10-MHz internal oscillator.

**Table 8-27. 10-MHz Internal Oscillator Specifications**

Minimum	Typical	Maximum	Unit
5	6.5	10	MHz

The user watchdog timer begins counting after the application configuration enters device user mode. This timer must be periodically reloaded or reset by the application configuration before the timer expires by asserting RU\_nRSTIMER. If the application configuration does not reload the user watchdog timer before the count expires, a time-out signal is generated by the remote system upgrade dedicated circuitry. The time-out signal tells the remote system upgrade circuitry to set the user watchdog timer status bit (Wd) in the remote system upgrade status register and reconfigures the device by loading the factory configuration.



To allow the remote system upgrade dedicated circuitry to reset the watchdog timer, you must assert the RU\_nRSTIMER signal active for a minimum of 250 ns. This is equivalent to strobing the reset\_timer input of the ALTREMOTE\_UPDATE megafunction high for a minimum of 250 ns.

Errors during configuration are detected by the CRC engine. Functional errors must not exist in the factory configuration because it is stored and validated during production and is never updated remotely.

 The user watchdog timer is disabled in factory configurations and during the configuration cycle of the application configuration. It is enabled after the application configuration enters user mode.

## Quartus II Software Support

Implementation in your design requires a remote system upgrade interface between the Cyclone IV device logic array and remote system upgrade circuitry. You must also generate configuration files for production and remote programming of the system configuration memory. The Quartus II software provides these features.

The two implementation options, ALTREMOTE\_UPDATE megafunction and remote system upgrade atom, are for the interface between the remote system upgrade circuitry and the device logic array interface. Using the megafunction block instead of creating your own logic saves design time and offers more efficient logic synthesis and device implementation.

 For more information about the ALTREMOTE\_UPDATE megafunction, refer to the *Remote Update Circuitry (ALTREMOTE\_UPDATE) Megafunction User Guide*.

## Document Revision History

Table 8-28 lists the revision history for this chapter.

**Table 8-28. Document Revision History (Part 1 of 2)**

Date	Version	Changes
May 2013	1.7	<ul style="list-style-type: none"> <li>■ Added Table 8-6.</li> <li>■ Updated Table 8-9 to add new device options and packages.</li> <li>■ Updated Figure 8-16 and Figure 8-22 to include user mode.</li> <li>■ Updated the “Dedicated” column for DATA[0] and DCLK in Table 8-19.</li> <li>■ Updated the “User Mode” and “Pin Type” columns for DCLK in Table 8-20.</li> </ul>
February 2013	1.6	Updated Table 8-9 to add new device options and packages.
October 2012	1.5	<ul style="list-style-type: none"> <li>■ Updated “AP Configuration Supported Flash Memories”, “Configuration Data Decompression”, and “Overriding the Internal Oscillator” sections.</li> <li>■ Updated Figure 8-3, Figure 8-4, Figure 8-5, Figure 8-7, Figure 8-8, Figure 8-9, Figure 8-10, and Figure 8-11.</li> <li>■ Updated Table 8-2, Table 8-8, Table 8-12, Table 8-13, Table 8-18, and Table 8-19.</li> </ul>
November 2011	1.4	<ul style="list-style-type: none"> <li>■ Added information about how to gain control of EPCS pins.</li> <li>■ Updated “Reset”, “Single-Device AS Configuration”, “Single-Device AP Configuration”, and “Overriding the Internal Oscillator” sections.</li> <li>■ Added Table 8-7.</li> <li>■ Updated Table 8-6 and Table 8-19.</li> <li>■ Updated Figure 8-3, Figure 8-4, and Figure 8-5.</li> </ul>
December 2010	1.3	<ul style="list-style-type: none"> <li>■ Updated for the Quartus II software version 10.1 release.</li> <li>■ Added Cyclone IV E new device package information.</li> <li>■ Updated Table 8-7, Table 8-10, and Table 8-11.</li> <li>■ Minor text edits.</li> </ul>

**Table 8-28. Document Revision History (Part 2 of 2)**

Date	Version	Changes
July 2010	1.2	Updated for the Quartus II software 10.0 release: <ul style="list-style-type: none"> <li>■ Updated “Power-On Reset (POR) Circuit”, “Configuration and JTAG Pin I/O Requirements”, and “Reset” sections.</li> <li>■ Updated Figure 8-10.</li> <li>■ Updated Table 8-16 and Table 8-17.</li> </ul>
February 2010	1.1	Updated for the Quartus II software 9.1 SP1 release: <ul style="list-style-type: none"> <li>■ Added “Overriding the Internal Oscillator” and “AP Configuration (Supported Flash Memories)” sections.</li> <li>■ Updated “JTAG Instructions” section.</li> <li>■ Added Table 8-6.</li> <li>■ Updated Table 8-2, Table 8-3, Table 8-4, Table 8-6, Table 8-11, Table 8-13, Table 8-14, Table 8-15, and Table 8-18.</li> <li>■ Updated Figure 8-4, Figure 8-5, Figure 8-6, Figure 8-13, Figure 8-14, Figure 8-15, Figure 8-17, Figure 8-18, Figure 8-23, Figure 8-24, Figure 8-25, Figure 8-26, Figure 8-27, Figure 8-28, and Figure 8-29.</li> </ul>
November 2009	1.0	Initial release.



This chapter describes the cyclical redundancy check (CRC) error detection feature in user mode and how to recover from soft errors.



Configuration error detection is supported in all Cyclone® IV devices including Cyclone IV GX devices, Cyclone IV E devices with 1.0-V core voltage, and Cyclone IV E devices with 1.2-V core voltage. However, user mode error detection is only supported in Cyclone IV GX devices and Cyclone IV E devices with 1.2-V core voltage.

Dedicated circuitry built into Cyclone IV devices consists of a CRC error detection feature that can optionally check for a single-event upset (SEU) continuously and automatically.

In critical applications used in the fields of avionics, telecommunications, system control, medical, and military applications, it is important to be able to:

- Confirm the accuracy of the configuration data stored in an FPGA device
- Alert the system to an occurrence of a configuration error

Using the CRC error detection feature for Cyclone IV devices does not impact fitting or performance.

This chapter contains the following sections:

- “Configuration Error Detection” on page 9–1
- “User Mode Error Detection” on page 9–2
- “Automated SEU Detection” on page 9–3
- “CRC\_ERROR Pin” on page 9–3
- “Error Detection Block” on page 9–4
- “Error Detection Timing” on page 9–5
- “Software Support” on page 9–6
- “Recovering from CRC Errors” on page 9–9

## Configuration Error Detection



Configuration error detection is available in all Cyclone IV devices including Cyclone IV GX devices, Cyclone IV E devices with 1.0-V core voltage, and Cyclone IV E devices with 1.2-V core voltage.

Configuration error detection determines if the configuration data received through an external memory device is corrupted during configuration. To validate the configuration data, the Quartus® II software uses a function to calculate the CRC value for each configuration data frame and stores the frame-based CRC value in the configuration data as part of the configuration bit stream.

During configuration, Cyclone IV devices use the same methodology to calculate the CRC value based on the frame of data that is received and compares it against the frame CRC value in the data stream. Configuration continues until either the device detects an error or all the values are calculated.

In addition to the frame-based CRC value, the Quartus II software generates a 32-bit CRC value for the whole configuration bit stream. This 32-bit CRC value is stored in the 32-bit storage register at the end of the configuration and is used for user mode error detection that is discussed in “[User Mode Error Detection](#)”.

## User Mode Error Detection

 User mode error detection is available in Cyclone IV GX and Cyclone IV E devices with 1.2-V core voltage. Cyclone IV E devices with 1.0-V core voltage do not support user mode error detection.

Soft errors are changes in a configuration random-access memory (CRAM) bit state due to an ionizing particle. Cyclone IV devices have built-in error detection circuitry to detect data corruption by soft errors in the CRAM cells.

This error detection capability continuously computes the CRC of the configured CRAM bits based on the contents of the device and compares it with the pre-calculated CRC value obtained at the end of the configuration. If the CRCs match, there is no error in the current configuration CRAM bits. The process of error detection continues until the device is reset (by setting `nCONFIG` to low).

The Cyclone IV device error detection feature does not check memory blocks and I/O buffers. These device memory blocks support parity bits that are used to check the contents of memory blocks for any error. The I/O buffers are not verified during error detection because the configuration data uses flip-flops as storage elements that are more resistant to soft errors. Similar flip-flops are used to store the pre-calculated CRC and other error detection circuitry option bits.

The error detection circuitry in Cyclone IV devices uses a 32-bit CRC IEEE 802 standard and a 32-bit polynomial as the CRC generator. Therefore, a single 32-bit CRC calculation is performed by the device. If a soft error does not occur, the resulting 32-bit signature value is `0x00000000`, that results in a 0 on the `CRC_ERROR` output signal. If a soft error occurs in the device, the resulting signature value is non-zero and the `CRC_ERROR` output signal is 1.

You can inject a soft error by changing the 32-bit CRC storage register in the CRC circuitry. After verifying the induced failure, you can restore the 32-bit CRC value to the correct CRC value with the same instruction and inserting the correct value.

 Before updating it with a known bad value, Altera recommends reading out the correct value.

In user mode, Cyclone IV devices support the `CHANGE_EDREG` JTAG instruction, that allows you to write to the 32-bit storage register. You can use Jam™ STAPL files (`.jam`) to automate the testing and verification process. You can only execute this instruction when the device is in user mode, and it is a powerful design feature that enables you to dynamically verify the CRC functionality in-system without having to reconfigure the device. You can then use the CRC circuit to check for real errors induced by an SEU.

Table 9-1 describes the `CHANGE_EDREG` JTAG instructions.

**Table 9-1. CHANGE\_EDREG JTAG Instruction**

JTAG Instruction	Instruction Code	Description
<code>CHANGE_EDREG</code>	00 0001 0101	This instruction connects the 32-bit CRC storage register between TDI and TDO. Any precomputed CRC is loaded into the CRC storage register to test the operation of the error detection CRC circuitry at the <code>CRC_ERROR</code> pin.

 After the test completes, Altera recommends that you power cycle the device.

## Automated SEU Detection

Cyclone IV devices offer on-chip circuitry for automated checking of SEU detection. Applications that require the device to operate error-free at high elevations or in close proximity to earth’s north or south pole require periodic checks to ensure continued data integrity. The error detection cyclic redundancy code feature controlled by the **Device and Pin Options** dialog box in the Quartus II software uses a 32-bit CRC circuit to ensure data reliability and is one of the best options for mitigating SEU.

You can implement the error detection CRC feature with existing circuitry in Cyclone IV devices, eliminating the need for external logic. The CRC is computed by the device during configuration and checked against an automatically computed CRC during normal operation. The `CRC_ERROR` pin reports a soft error when configuration CRAM data is corrupted. You must decide whether to reconfigure the FPGA by strobing the `nCONFIG` pin low or ignore the error.

## CRC\_ERROR Pin

A specific `CRC_ERROR` error detection pin is required to monitor the results of the error detection circuitry during user mode. Table 9-2 describes the `CRC_ERROR` pin.

**Table 9-2. Cyclone IV Device CRC\_ERROR Pin Description**

CRC_ERROR Pin Type	Description
I/O, Output (open-drain)	Active high signal indicates that the error detection circuit has detected errors in the configuration SRAM bits. This pin is optional and is used when the CRC error detection circuit is enabled in the Quartus II software from the <b>Error Detection CRC</b> tab of the <b>Device and Pin Options</b> dialog box.  When using this pin, connect it to an external 10-kΩ pull-up resistor to an acceptable voltage that satisfies the input voltage of the receiving device.

 The `CRC_ERROR` pin information for Cyclone IV devices is reported in the [Cyclone IV Devices Pin-Outs](#) on the Altera® website.

 WYSIWYG is an optimization technique that performs optimization on a VQM (Verilog Quartus Mapping) netlist in the Quartus II software.

## Error Detection Block

Table 9-3 lists the types of CRC detection to check the configuration bits.

**Table 9-3. Types of CRC Detection to Check the Configuration Bits**

First Type of CRC Detection	Second Type of CRC Detection
<ul style="list-style-type: none"> <li>■ CRAM error checking ability (32-bit CRC) during user mode, for use by the CRC_ERROR pin.</li> <li>■ There is only one 32-bit CRC value. This value covers all the CRAM data.</li> </ul>	<ul style="list-style-type: none"> <li>■ 16-bit CRC embedded in every configuration data frame.</li> <li>■ During configuration, after a frame of data is loaded into the device, the pre-computed CRC is shifted into the CRC circuitry.</li> <li>■ Simultaneously, the CRC value for the data frame shifted-in is calculated. If the pre-computed CRC and calculated CRC values do not match, nSTATUS is set low.</li> <li>■ Every data frame has a 16-bit CRC. Therefore, there are many 16-bit CRC values for the whole configuration bit stream.</li> <li>■ Every device has a different length of configuration data frame.</li> </ul>

This section focuses on the first type—the 32-bit CRC when the device is in user mode.

## Error Detection Registers

There are two sets of 32-bit registers in the error detection circuitry that store the computed CRC signature and pre-calculated CRC value. A non-zero value on the signature register causes the CRC\_ERROR pin to set high.

Figure 9-1 shows the block diagram of the error detection block and the two related 32-bit registers: the signature register and the storage register.

**Figure 9-1. Error Detection Block Diagram**

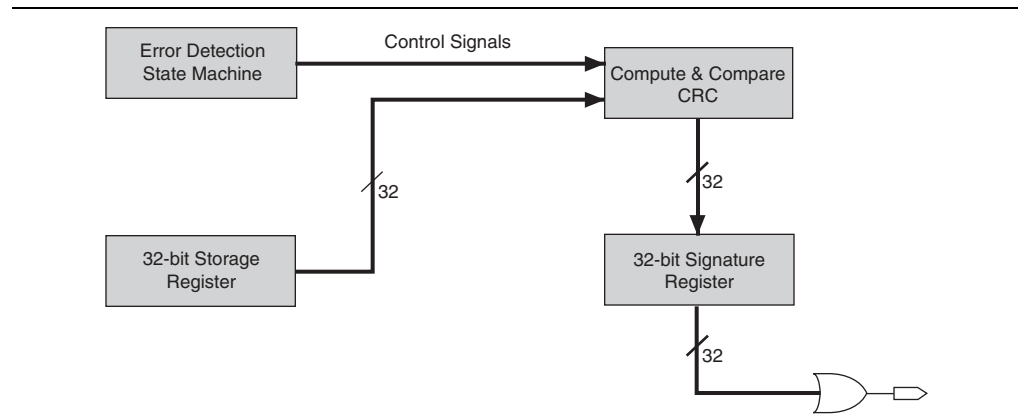

Table 9-4 defines the registers shown in Figure 9-1.

**Table 9-4. Error Detection Registers**

Register	Function
32-bit signature register	This register contains the CRC signature. The signature register contains the result of the user mode calculated CRC value compared against the pre-calculated CRC value. If no errors are detected, the signature register is all zeros. A non-zero signature register indicates an error in the configuration CRAM contents.  The CRC_ERROR signal is derived from the contents of this register.
32-bit storage register	This register is loaded with the 32-bit pre-computed CRC signature at the end of the configuration stage. The signature is then loaded into the 32-bit CRC circuit (called the Compute and Compare CRC block, as shown in Figure 9-1) during user mode to calculate the CRC error. This register forms a 32-bit scan chain during execution of the CHANGE_EDREG JTAG instruction. The CHANGE_EDREG JTAG instruction can change the content of the storage register. Therefore, the functionality of the error detection CRC circuitry is checked in-system by executing the instruction to inject an error during the operation. The operation of the device is not halted when issuing the CHANGE_EDREG instruction.

## Error Detection Timing

When the error detection CRC feature is enabled through the Quartus II software, the device automatically activates the CRC process upon entering user mode after configuration and initialization is complete.

The CRC\_ERROR pin is driven low until the error detection circuitry detects a corrupted bit in the previous CRC calculation. After the pin goes high, it remains high during the next CRC calculation. This pin does not log the previous CRC calculation. If the new CRC calculation does not contain any corrupted bits, the CRC\_ERROR pin is driven low. The error detection runs until the device is reset.

The error detection circuitry runs off an internal configuration oscillator with a divisor that sets the maximum frequency.

Table 9-5 lists the minimum and maximum error detection frequencies.

**Table 9-5. Minimum and Maximum Error Detection Frequencies for Cyclone IV Devices**

Error Detection Frequency	Maximum Error Detection Frequency	Minimum Error Detection Frequency	Valid Divisors (2 <sup>n</sup> )
80 MHz/2 <sup>n</sup>	80 MHz	312.5 kHz	0, 1, 2, 3, 4, 5, 6, 7, 8

You can set a lower clock frequency by specifying a division factor in the Quartus II software (for more information, refer to “Software Support”). The divisor is a power of two (2), where *n* is between 0 and 8. The divisor ranges from one through 256. Refer to Equation 9-1.

**Equation 9-1.**

$$\text{Error detection frequency} = \frac{80 \text{ MHz}}{2^n}$$

CRC calculation time depends on the device and the error detection clock frequency.

Table 9-6 lists the estimated time for each CRC calculation with minimum and maximum clock frequencies for Cyclone IV devices.

**Table 9-6. CRC Calculation Time**

Device		Minimum Time (ms) <sup>(1)</sup>	Maximum Time (s) <sup>(2)</sup>
Cyclone IV E	EP4CE6 <sup>(3)</sup>	5	2.29
	EP4CE10 <sup>(3)</sup>	5	2.29
	EP4CE15 <sup>(3)</sup>	7	3.17
	EP4CE22 <sup>(3)</sup>	9	4.51
	EP4CE30 <sup>(3)</sup>	15	7.48
	EP4CE40 <sup>(3)</sup>	15	7.48
	EP4CE55 <sup>(3)</sup>	23	11.77
	EP4CE75 <sup>(3)</sup>	31	15.81
	EP4CE115 <sup>(3)</sup>	45	22.67
Cyclone IV GX	EP4CGX15	6	2.93
	EP4CGX22	12	5.95
	EP4CGX30	12	5.95
		34 <sup>(4)</sup>	17.34 <sup>(4)</sup>
	EP4CGX50	34	17.34
	EP4CGX75	34	17.34
	EP4CGX110	62	31.27
	EP4CGX150	62	31.27

**Notes to Table 9-6:**

- (1) The minimum time corresponds to the maximum error detection clock frequency and may vary with different processes, voltages, and temperatures (PVT).
- (2) The maximum time corresponds to the minimum error detection clock frequency and may vary with different PVT.
- (3) Only applicable for device with 1.2-V core voltage
- (4) Only applicable for the F484 device package.

## Software Support

Enabling the CRC error detection feature in the Quartus II software generates the CRC\_ERROR output to the optional dual purpose CRC\_ERROR pin.

To enable the error detection feature using CRC, perform the following steps:

1. Open the Quartus II software and load a project using Cyclone IV devices.
2. On the Assignments menu, click **Settings**. The **Settings** dialog box appears.
3. In the Category list, select **Device**. The **Device** page appears.
4. Click **Device and Pin Options**. The **Device and Pin Options** dialog box appears as shown in Figure 9-2.
5. In the **Device and Pin Options** dialog box, click the **Error Detection CRC** tab.
6. Turn on **Enable error detection CRC**.
7. In the **Divide error check frequency by** box, enter a valid divisor as documented in Table 9-5 on page 9-5.

 The divisor value divides the frequency of the configuration oscillator output clock. This output clock is used as the clock source for the error detection process.

8. Click OK.

**Figure 9-2. Enabling the Error Detection CRC Feature in the Quartus II Software**

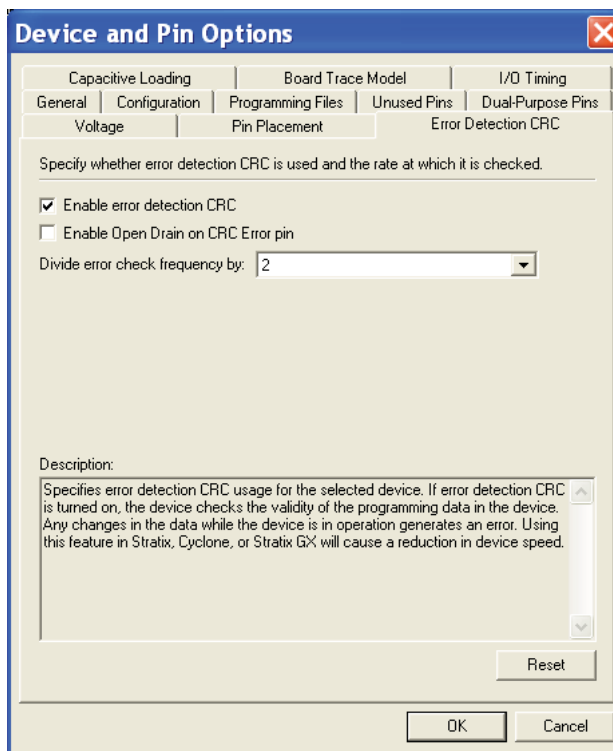

## Accessing Error Detection Block Through User Logic

The error detection circuit stores the computed 32-bit CRC signature in a 32-bit register, which is read out by user logic from the core. The `cycloneiv_crcblock` primitive is a WYSIWYG component used to establish the interface from the user logic to the error detection circuit. The `cycloneiv_crcblock` primitive atom contains the input and output ports that must be included in the atom. To access the logic array, the `cycloneiv_crcblock` WYSIWYG atom must be inserted into your design.

Figure 9-3 shows the error detection block diagram in FPGA devices and shows the interface that the WYSIWYG atom enables in your design.

**Figure 9-3. Error Detection Block Diagram**

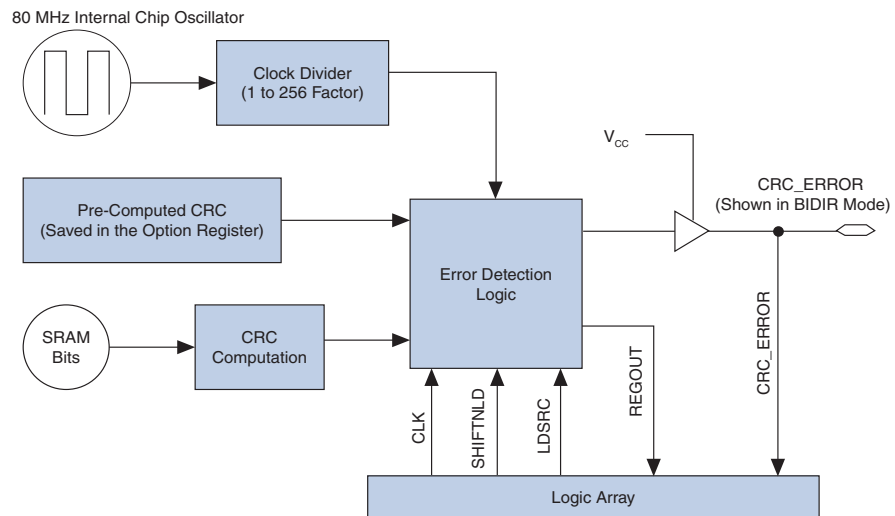

The user logic is affected by the soft error failure, so reading out the 32-bit CRC signature through the `regout` should not be relied upon to detect a soft error. You should rely on the `CRC_ERROR` output signal itself, because this `CRC_ERROR` output signal cannot be affected by a soft error.

To enable the `cycloneiv_crcblock` WYSIWYG atom, you must name the atom for each Cyclone IV device accordingly.

Example 9-1 shows an example of how to define the input and output ports of a WYSIWYG atom in a Cyclone IV device.

**Example 9-1. Error Detection Block Diagram**

```
cycloneiv_crcblock<crckblock_name>
(
  .clk(<clock source>),
  .shiftnld(<shiftnld source>),
  .ldsrc(<ldsrc source>),
  .crcerror(<crcerror out destination>),
  .regout(<output destination>),
);
```

Table 9-7 lists the input and output ports that you must include in the atom.

**Table 9-7. CRC Block Input and Output Ports**

Port	Input/Output	Definition
<i>&lt;crcblock_name&gt;</i>	Input	Unique identifier for the CRC block, and represents any identifier name that is legal for the given description language (for example, Verilog HDL, VHDL, and AHDL). This field is required.
<i>.clk</i> ( <i>&lt;clock source&gt;</i> )	Input	This signal designates the clock input of this cell. All operations of this cell are with respect to the rising edge of the clock. Whether it is the loading of the data into the cell or data out of the cell, it always occurs on the rising edge. This port is required.
<i>.shiftnld</i> ( <i>&lt;shiftnld source&gt;</i> )	Input	This signal is an input into the error detection block. If <i>shiftnld</i> =1, the data is shifted from the internal shift register to the <i>regout</i> at each rising edge of <i>clk</i> . If <i>shiftnld</i> =0, the shift register parallel loads either the pre-calculated CRC value or the update register contents, depending on the <i>ldsrc</i> port input. To do this, the <i>shiftnld</i> must be driven low for at least two clock cycles. This port is required.
<i>.ldsrc</i> ( <i>&lt;ldsrc source&gt;</i> )	Input	This signal is an input into the error detection block. If <i>ldsrc</i> =0, the pre-computed CRC register is selected for loading into the 32-bit shift register at the rising edge of <i>clk</i> when <i>shiftnld</i> =0. If <i>ldsrc</i> =1, the signature register (result of the CRC calculation) is selected for loading into the shift register at the rising edge of <i>clk</i> when <i>shiftnld</i> =0. This port is ignored when <i>shiftnld</i> =1. This port is required.
<i>.crcerror</i> ( <i>&lt;crcerror indicator output&gt;</i> )	Output	This signal is the output of the cell that is synchronized to the internal oscillator of the device (80-MHz internal oscillator) and not to the <i>clk</i> port. It asserts high if the error block detects that a SRAM bit has flipped and the internal CRC computation has shown a difference with respect to the pre-computed value. You must connect this signal either to an output pin or a bidirectional pin. If it is connected to an output pin, you can only monitor the <i>CRC_ERROR</i> pin (the core cannot access this output). If the <i>CRC_ERROR</i> signal is used by core logic to read error detection logic, you must connect this signal to a <i>BIDIR</i> pin. The signal is fed to the core indirectly by feeding a <i>BIDIR</i> pin that has its output enable port connected to <i>V<sub>CC</sub></i> (see <a href="#">Figure 9-3 on page 9-8</a> ).
<i>.regout</i> ( <i>&lt;registered output&gt;</i> )	Output	This signal is the output of the error detection shift register synchronized to the <i>clk</i> port to be read by core logic. It shifts one bit at each cycle, so you should clock the <i>clk</i> signal 31 cycles to read out the 32 bits of the shift register.

## Recovering from CRC Errors

The system that the Altera FPGA resides in must control device reconfiguration. After detecting an error on the *CRC\_ERROR* pin, strobing the *nCONFIG* low directs the system to perform the reconfiguration at a time when it is safe for the system to reconfigure the FPGA.

When the data bit is rewritten with the correct value by reconfiguring the device, the device functions correctly.

While soft errors are uncommon in Altera devices, certain high-reliability applications might require a design to account for these errors.

## Document Revision History

Table 9-8 lists the revision history for this chapter.

**Table 9-8. Document Revision History**

Date	Version	Changes
May 2013	1.3	Updated “CRC_ERROR Pin Type” in <a href="#">Table 9-2</a> .
October 2012	1.2	Updated Table 9-2.
February 2010	1.1	Updated for the Quartus II software version 9.1 SP1 release: <ul style="list-style-type: none"> <li>■ Updated “Configuration Error Detection” section.</li> <li>■ Updated Table 9-6.</li> <li>■ Added Cyclone IV E devices in Table 9-6.</li> </ul>
November 2009	1.0	Initial release.

This chapter describes the boundary-scan test (BST) features that are supported in Cyclone® IV devices. The features are similar to Cyclone III devices, unless stated in this chapter.

Cyclone IV devices (Cyclone IV E devices and Cyclone IV GX devices) support IEEE Std. 1149.1. Cyclone IV GX devices also support IEEE Std. 1149.6. The IEEE Std. 1149.6 (AC JTAG) is only supported on the high-speed serial interface (HSSI) transceivers in Cyclone IV GX devices. The purpose of IEEE Std. 1149.6 is to enable board-level connectivity checking between transmitters and receivers that are AC coupled.

This chapter includes the following sections:

- “IEEE Std. 1149.6 Boundary-Scan Register” on page 10–2
- “BST Operation Control” on page 10–3
- “I/O Voltage Support in a JTAG Chain” on page 10–5
- “Boundary-Scan Description Language Support” on page 10–6

 For more information about the JTAG instructions code with descriptions and IEEE Std. 1149.1 BST guidelines, refer to the *IEEE 1149.1 (JTAG) Boundary-Scan Testing for Cyclone III Devices* chapter.

 For more information about the following topics, refer to *AN 39: IEEE 1149.1 (JTAG) Boundary-Scan Testing in Altera Devices*:

- IEEE Std. 1149.1 BST architecture and circuitry
- TAP controller state-machine
- Instruction mode

## IEEE Std. 1149.6 Boundary-Scan Register

The boundary-scan cell (BSC) for HSSI transmitters (GXB\_TX[p, n]) and receivers (GXB\_RX[p, n]) in Cyclone IV GX devices are different from the BSCs for I/O pins.

Figure 10-1 shows the Cyclone IV GX HSSI transmitter boundary-scan cell.

**Figure 10-1. HSSI Transmitter BSC with IEEE Std. 1149.6 BST Circuitry for Cyclone IV GX Devices**

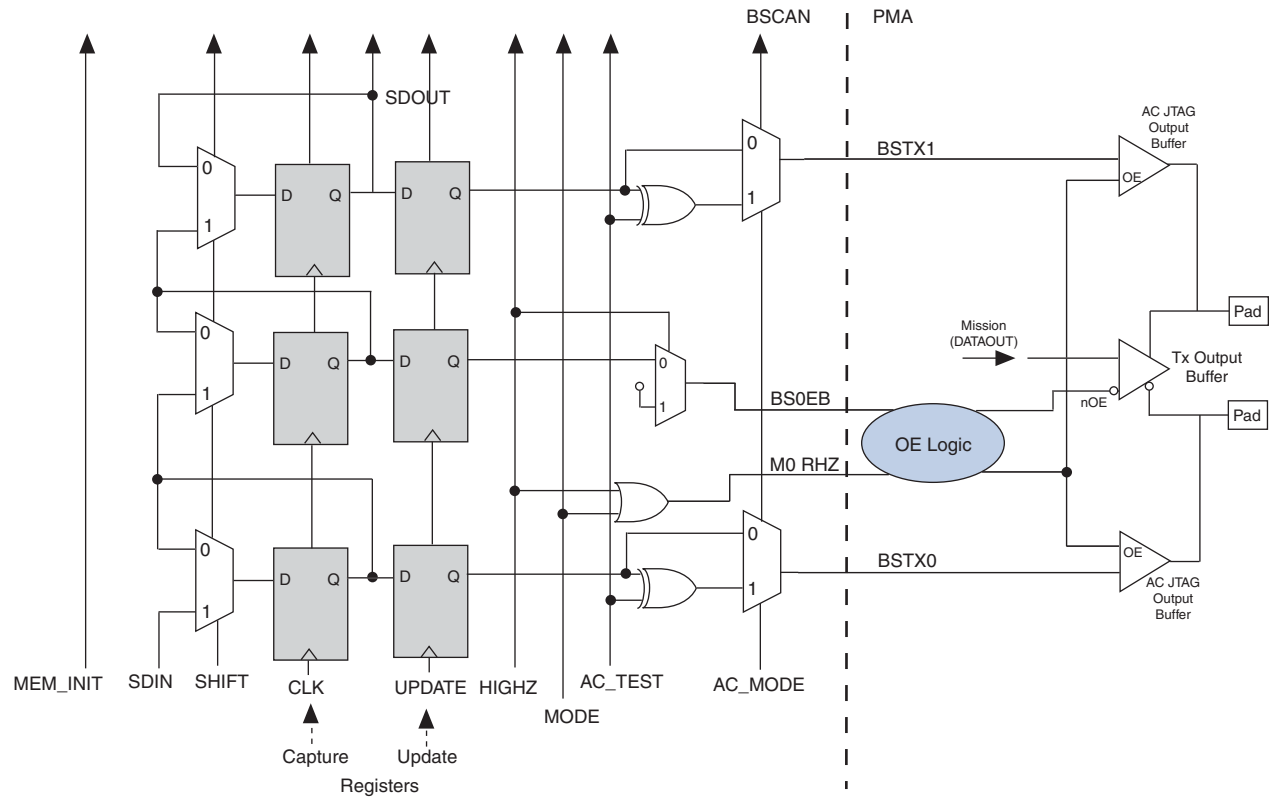
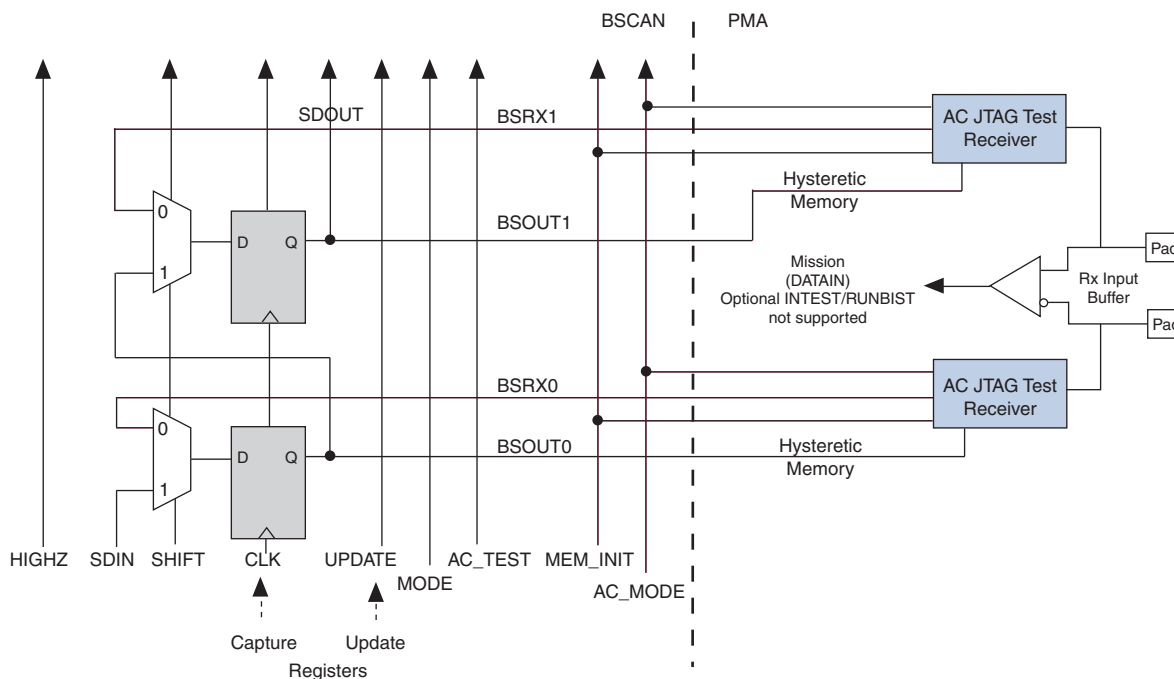

Figure 10-2 shows the Cyclone IV GX HSSI receiver BSC.

**Figure 10-2. HSSI Receiver BSC with IEEE Std. 1149.6 BST Circuitry for the Cyclone IV GX Devices**



For more information about Cyclone IV devices user I/O boundary-scan cells, refer to the *IEEE 1149.1 (JTAG) Boundary-Scan Testing for Cyclone III Devices* chapter.

## BST Operation Control

Table 10-1 lists the boundary-scan register length for Cyclone IV devices.

**Table 10-1. Boundary-Scan Register Length for Cyclone IV Devices (Part 1 of 2)**

Device	Boundary-Scan Register Length
EP4CE6	603
EP4CE10	603
EP4CE15	1080
EP4CE22	732
EP4CE30	1632
EP4CE40	1632
EP4CE55	1164
EP4CE75	1314
EP4CE115	1620
EP4CGX15	260
EP4CGX22	494
EP4CGX30 <sup>(1)</sup>	494
EP4CGX50	1006

**Table 10-1. Boundary-Scan Register Length for Cyclone IV Devices (Part 2 of 2)**

Device	Boundary-Scan Register Length
EP4CGX75	1006
EP4CGX110	1495
EP4CGX150	1495

**Note to Table 10-1:**

(1) For the F484 package of the EP4CGX30 device, the boundary-scan register length is 1006.

Table 10-2 lists the IDCODE information for Cyclone IV devices.

**Table 10-2. IDCODE Information for 32-Bit Cyclone IV Devices**

Device	IDCODE (32 Bits) <sup>(1)</sup>			
	Version (4 Bits)	Part Number (16 Bits)	Manufacturer Identity (11 Bits)	LSB (1 Bit) <sup>(2)</sup>
EP4CE6	0000	0010 0000 1111 0001	000 0110 1110	1
EP4CE10	0000	0010 0000 1111 0001	000 0110 1110	1
EP4CE15	0000	0010 0000 1111 0010	000 0110 1110	1
EP4CE22	0000	0010 0000 1111 0011	000 0110 1110	1
EP4CE30	0000	0010 0000 1111 0100	000 0110 1110	1
EP4CE40	0000	0010 0000 1111 0100	000 0110 1110	1
EP4CE55	0000	0010 0000 1111 0101	000 0110 1110	1
EP4CE75	0000	0010 0000 1111 0110	000 0110 1110	1
EP4CE115	0000	0010 0000 1111 0111	000 0110 1110	1
EP4CGX15	0000	0010 1000 0000 0001	000 0110 1110	1
EP4CGX22	0000	0010 1000 0001 0010	000 0110 1110	1
EP4CGX30 <sup>(3)</sup>	0000	0010 1000 0000 0010	000 0110 1110	1
EP4CGX30 <sup>(4)</sup>	0000	0010 1000 0010 0011	000 0110 1110	1
EP4CGX50	0000	0010 1000 0001 0011	000 0110 1110	1
EP4CGX75	0000	0010 1000 0000 0011	000 0110 1110	1
EP4CGX110	0000	0010 1000 0001 0100	000 0110 1110	1
EP4CGX150	0000	0010 1000 0000 0100	000 0110 1110	1

**Notes to Table 10-2:**

- (1) The MSB is on the left.
- (2) The IDCODE LSB is always 1.
- (3) The IDCODE is applicable for all packages except for the F484 package.
- (4) The IDCODE is applicable for the F484 package only.

IEEE Std.1149.6 mandates the addition of two new instructions: EXTEST\_PULSE and EXTEST\_TRAIN. These two instructions enable edge-detecting behavior on the signal path containing the AC pins.

## EXTEST\_PULSE

The instruction code for EXTEST\_PULSE is 0010001111. The EXTEST\_PULSE instruction generates three output transitions:

- Driver drives data on the falling edge of TCK in UPDATE\_IR/DR.
- Driver drives inverted data on the falling edge of TCK after entering the RUN\_TEST/IDLE state.
- Driver drives data on the falling edge of TCK after leaving the RUN\_TEST/IDLE state.

 If you use DC-coupling on HSSI signals, you must execute the EXTEST instruction. If you use AC-coupling on HSSI signals, you must execute the EXTEST\_PULSE instruction. AC-coupled and DC-coupled HSSI are only supported in post-configuration mode.

## EXTEST\_TRAIN

The instruction code for EXTEST\_TRAIN is 0001001111. The EXTEST\_TRAIN instruction behaves the same as the EXTEST\_PULSE instruction with one exception. The output continues to toggle on the TCK falling edge as long as the test access port (TAP) controller is in the RUN\_TEST/IDLE state.

 These two instruction codes are only supported in post-configuration mode for Cyclone IV GX devices.

 When you perform JTAG boundary-scan testing before configuration, the nCONFIG pin must be held low.

## I/O Voltage Support in a JTAG Chain

A Cyclone IV device operating in BST mode uses four required pins: TDI, TDO, TMS, and TCK. The TDO output pin and all JTAG input pins are powered by the  $V_{CCIO}$  power supply of I/O Banks (I/O Bank 9 for Cyclone IV GX devices and I/O Bank 1 for Cyclone IV E devices).

A JTAG chain can contain several different devices. However, you must use caution if the chain contains devices that have different  $V_{CCIO}$  levels. The output voltage level of the TDO pin must meet the specification of the TDI pin it drives. For example, a device with a 3.3-V TDO pin can drive a device with a 5.0-V TDI pin because 3.3 V meets the minimum TTL-level  $V_{IH}$  for the 5.0-V TDI pin.

 For multiple devices in a JTAG chain with the 3.0-V/3.3-V I/O standard, you must connect a 25- $\Omega$  series resistor on a TDO pin driving a TDI pin.

You can also interface the TDI and TDO lines of the devices that have different  $V_{CCIO}$  levels by inserting a level shifter between the devices. If possible, the JTAG chain should have a device with a higher  $V_{CCIO}$  level driving a device with an equal or lower  $V_{CCIO}$  level. This way, a level shifter may be required only to shift the TDO level to a level acceptable to the JTAG tester.

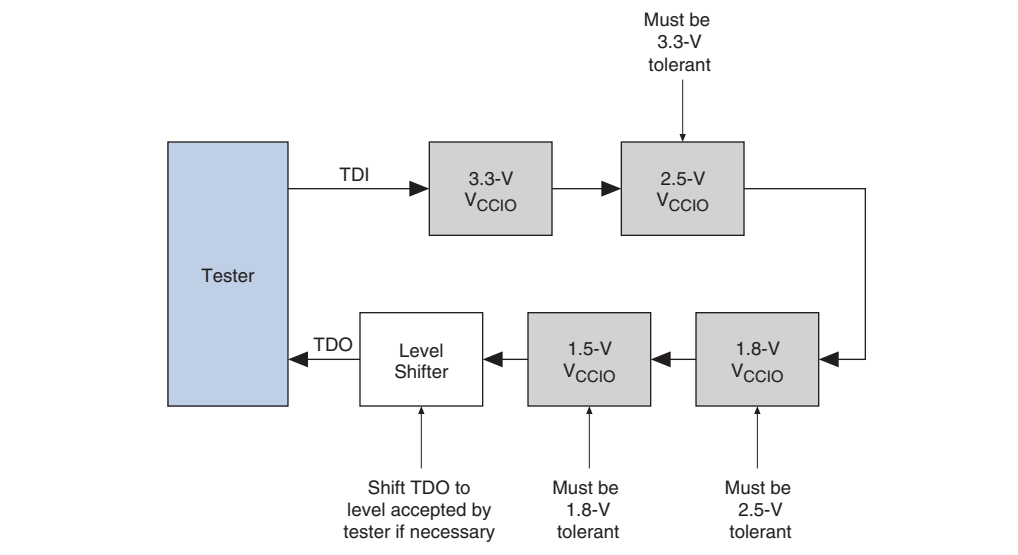

Figure 10-3 shows the JTAG chain of mixed voltages and how a level shifter is inserted in the chain.

**Figure 10-3. JTAG Chain of Mixed Voltages**



## Boundary-Scan Description Language Support

The boundary-scan description language (BSDL), a subset of VHDL, provides a syntax that allows you to describe the features of an IEEE Std. 1149.1/IEEE Std. 1149.6 BST-capable device that can be tested.

- 
 For more information about how to download BSDL files for IEEE Std. 1149.1-compliant Cyclone IV E devices, refer to [IEEE Std. 1149.1 BSDL Files](#).
- 
 For more information about how to download BSDL files for IEEE Std. 1149.6-compliant Cyclone IV GX devices, refer to [IEEE Std. 1149.6 BSDL Files](#).
- 
 You can also generate BSDL files (pre-configuration and post-configuration) for IEEE Std. 1149.1/IEEE Std. 1149.6-compliant Cyclone IV devices with the Quartus® II software version 9.1 SP1 and later. For more information about the procedure to generate BSDL files using the Quartus II software, refer to [BSDL Files Generation in Quartus II](#).

## Document Revision History

Table 10-3 lists the revision history for this chapter.

**Table 10-3. Document Revision History**

<b>Date</b>	<b>Version</b>	<b>Changes</b>
December 2013	1.3	<ul style="list-style-type: none"><li>■ Updated the “EXTEST_PULSE” section.</li></ul>
November 2011	1.2	<ul style="list-style-type: none"><li>■ Updated the “BST Operation Control” section.</li><li>■ Updated Table 10-2.</li></ul>
February 2010	1.1	<ul style="list-style-type: none"><li>■ Added Cyclone IV E devices in Table 10-1 and Table 10-2 for the Quartus II software version 9.1 SP1 release.</li><li>■ Updated Figure 10-1 and Figure 10-2.</li><li>■ Minor text edits.</li></ul>
November 2009	1.0	Initial release.





This chapter describes information about external power supply requirements, hot-socketing specifications, power-on reset (POR) requirements, and their implementation in Cyclone IV devices.

This chapter includes the following sections:

- “External Power Supply Requirements” on page 11–1
- “Hot-Socketing Specifications” on page 11–2
- “Hot-socketing Feature Implementation” on page 11–3
- “Power-On Reset Circuitry” on page 11–3

## External Power Supply Requirements

This section describes the different external power supplies required to power Cyclone IV devices. Table 11–1 and Table 11–2 list the descriptions of external power supply pins for Cyclone IV GX and Cyclone IV E devices, respectively.

-  For each Altera recommended power supply’s operating conditions, refer to the *Cyclone IV Device Datasheet* chapter.
-  For power supply pin connection guidelines and power regulator sharing, refer to the *Cyclone IV Device Family Pin Connection Guidelines*.

**Table 11–1. Power Supply Descriptions for the Cyclone IV GX Devices (Part 1 of 2)**

Power Supply Pin	Nominal Voltage Level (V)	Description
VCCINT	1.2	Core voltage, PCI Express (PCIe) hard IP block, and transceiver physical coding sublayer (PCS) power supply
VCCA <sup>(1)</sup>	2.5	PLL analog power supply
VCCD_PLL	1.2	PLL digital power supply
VCCIO <sup>(2)</sup>	1.2, 1.5, 1.8, 2.5, 3.0, 3.3	I/O banks power supply
VCC_CLKIN <sup>(3), (4)</sup>	1.2, 1.5, 1.8, 2.5, 3.0, 3.3	Differential clock input pins power supply
VCCH_GXB	2.5	Transceiver output (TX) buffer power supply
VCCA_GXB	2.5	Transceiver physical medium attachment (PMA) and auxiliary power supply

© 2013 Altera Corporation. All rights reserved. ALTERA, ARRIA, CYCLONE, HARDCOPY, MAX, MEGACORE, NIOS, QUARTUS and STRATIX words and logos are trademarks of Altera Corporation and registered in the U.S. Patent and Trademark Office and in other countries. All other words and logos identified as trademarks or service marks are the property of their respective holders as described at [www.altera.com/common/legal.html](http://www.altera.com/common/legal.html). Altera warrants performance of its semiconductor products to current specifications in accordance with Altera’s standard warranty, but reserves the right to make changes to any products and services at any time without notice. Altera assumes no responsibility or liability arising out of the application or use of any information, product, or service described herein except as expressly agreed to in writing by Altera. Altera customers are advised to obtain the latest version of device specifications before relying on any published information and before placing orders for products or services.



**Table 11-1. Power Supply Descriptions for the Cyclone IV GX Devices (Part 2 of 2)**

Power Supply Pin	Nominal Voltage Level (V)	Description
VCCL_GXB	1.2	Transceiver PMA and auxiliary power supply

**Notes to Table 11-1:**

- (1) You must power up VCCA even if the phase-locked loop (PLL) is not used.
- (2) I/O banks 3, 8, and 9 contain configuration pins. You can only power up the V<sub>CCIO</sub> level of I/O banks 3 and 9 to 1.5 V, 1.8 V, 2.5 V, 3.0 V, or 3.3 V. For Fast Passive Parallel (FPP) configuration mode, you must power up the V<sub>CCIO</sub> level of I/O bank 8 to 1.5 V, 1.8 V, 2.5 V, 3.0 V, or 3.3 V.
- (3) All device packages of EP4CGX15, EP4CGX22, and device package F169 and F324 of EP4CGX30 devices have two VCC\_CLKIN dedicated clock input I/O located at Banks 3A and 8A. Device package F484 of EP4CGX30, all device packages of EP4CGX50, EP4CGX75, EP4CGX110, and EP4CGX150 devices have four VCC\_CLKIN dedicated clock input I/O bank located at banks 3A, 3B, 8A, and 8B.
- (4) You must set VCC\_CLKIN to 2.5V if the CLKIN is used as a high-speed serial interface (HSSI) transceiver refclk. When not used as a transceiver refclk, VCC\_CLKIN supports 1.2 V/ 1.5 V/ 1.8 V/ 2.5 V/ 3.0 V/ 3.3V voltages.

**Table 11-2. Power Supply Descriptions for the Cyclone IV E Devices**

Power Supply Pin	Nominal Voltage Level (V)	Description
VCCINT	1.0, 1.2	Core voltage power supply
VCCA (1)	2.5	PLL analog power supply
VCCD_PLL	1.0, 1.2	PLL digital power supply
VCCIO (2)	1.2, 1.5, 1.8, 2.5, 3.0, 3.3	I/O banks power supply

**Notes to Table 11-2:**

- (1) You must power up VCCA even if the PLL is not used.
- (2) I/O banks 1, 6, 7, and 8 contain configuration pins.

## Hot-Socketing Specifications

Cyclone IV devices are hot-socketing compliant without the need for any external components or special design requirements. Hot-socketing support in Cyclone IV devices has the following advantages:

- You can drive the device before power up without damaging the device.
- I/O pins remain tri-stated during power up. The device does not drive out before or during power-up. Therefore, it does not affect other buses in operation.

### Devices Driven Before Power-Up

You can drive signals into regular Cyclone IV E I/O pins and transceiver Cyclone IV GX I/O pins before or during power up or power down without damaging the device. Cyclone IV devices support any power-up or power-down sequence to simplify system-level designs.

### I/O Pins Remain Tri-stated During Power-Up

The output buffers of Cyclone IV devices are turned off during system power up or power down. Cyclone IV devices do not drive out until the device is configured and working in recommended operating conditions. The I/O pins are tri-stated until the device enters user mode.

 The user I/O pins and dual-purpose I/O pins have weak pull-up resistors, which are always enabled (after POR) before and during configuration. The weak pull up resistors are not enabled prior to POR.

A possible concern for semiconductor devices in general regarding hot socketing is the potential for latch up. Latch up can occur when electrical subsystems are hot socketed into an active system. During hot socketing, the signal pins may be connected and driven by the active system before the power supply can provide current to the  $V_{CC}$  of the device and ground planes. This condition can lead to latch up and cause a low-impedance path from  $V_{CC}$  to GND in the device. As a result, the device extends a large amount of current, possibly causing electrical damage.

The design of the I/O buffers and hot-socketing circuitry ensures that Cyclone IV devices are immune to latch up during hot-socketing.

 For more information about the hot-socketing specification, refer to the *Cyclone IV Device Datasheet* chapter and the *Hot-Socketing and Power-Sequencing Feature and Testing for Altera Devices* white paper.

## Hot-socketing Feature Implementation

The hot-socketing circuit does not include the `CONF_DONE`, `nCEO`, and `nSTATUS` pins to ensure that they are able to operate during configuration. The expected behavior for these pins is to drive out during power-up and power-down sequences.

 Altera uses GND as reference for hot-socketing operation and I/O buffer designs. To ensure proper operation, Altera recommends connecting the GND between boards before connecting the power supplies. This prevents the GND on your board from being pulled up inadvertently by a path to power through other components on your board. A pulled up GND can otherwise cause an out-of-specification I/O voltage or current condition with the Altera device.

## Power-On Reset Circuitry

Cyclone IV devices contain POR circuitry to keep the device in a reset state until the power supply voltage levels have stabilized during power up. During POR, all user I/O pins are tri-stated until the power supplies reach the recommended operating levels. In addition, the POR circuitry also ensures the  $V_{CCIO}$  level of I/O banks that contain configuration pins reach an acceptable level before configuration is triggered.

The POR circuit of the Cyclone IV device monitors the  $V_{CCINT}$ ,  $V_{CCA}$ , and  $V_{CCIO}$  that contain configuration pins during power-on. You can power up or power down the  $V_{CCINT}$ ,  $V_{CCA}$ , and  $V_{CCIO}$  pins in any sequence. The  $V_{CCINT}$ ,  $V_{CCA}$ , and  $V_{CCIO}$  must have a monotonic rise to their steady state levels. All  $V_{CCA}$  pins must be powered to 2.5V (even when PLLs are not used), and must be powered up and powered down at the same time.

After the Cyclone IV device enters the user mode, the POR circuit continues to monitor the  $V_{CCINT}$  and  $V_{CCA}$  pins so that a brown-out condition during user mode is detected. If the  $V_{CCINT}$  or  $V_{CCA}$  voltage sags below the POR trip point during user mode, the POR circuit resets the device. If the  $V_{CCIO}$  voltage sags during user mode, the POR circuit does not reset the device.

In some applications, it is necessary for a device to wake up very quickly to begin operation. Cyclone IV devices offer the Fast-On feature to support fast wake-up time applications. The MSEL pin settings determine the POR time ( $t_{POR}$ ) of the device.

 For more information about the MSEL pin settings, refer to the *Configuration and Remote System Upgrades in Cyclone IV Devices* chapter.

 For more information about the POR specifications, refer to the *Cyclone IV Device Datasheet* chapter.

## Document Revision History

Table 11-3 lists the revision history for this chapter.

**Table 11-3. Document Revision History**

Date	Version	Changes
May 2013	1.3	Updated Note (4) in Table 11-1.
July 2010	1.2	<ul style="list-style-type: none"> <li>■ Updated for the Quartus II software version 10.0 release.</li> <li>■ Updated “I/O Pins Remain Tri-stated During Power-Up” section.</li> <li>■ Updated Table 11-1.</li> </ul>
February 2010	1.1	Updated Table 11-1 and Table 11-2 for the Quartus II software version 9.1 SP1 release.
November 2009	1.0	Initial release.



# **Cyclone IV Device Handbook,**

---

## **Volume 2**



101 Innovation Drive  
San Jose, CA 95134  
[www.altera.com](http://www.altera.com)

CYIV-5V2-1.9

© 2015 Altera Corporation. All rights reserved. ALTERA, ARRIA, CYCLONE, HARDCOPY, MAX, MEGACORE, NIOS, QUARTUS and STRATIX words and logos are trademarks of Altera Corporation and registered in the U.S. Patent and Trademark Office and in other countries. All other words and logos identified as trademarks or service marks are the property of their respective holders as described at [www.altera.com/common/legal.html](http://www.altera.com/common/legal.html). Altera warrants performance of its semiconductor products to current specifications in accordance with Altera's standard warranty, but reserves the right to make changes to any products and services at any time without notice. Altera assumes no responsibility or liability arising out of the application or use of any information, product, or service described herein except as expressly agreed to in writing by Altera. Altera customers are advised to obtain the latest version of device specifications before relying on any published information and before placing orders for products or services.



<b>Chapter Revision Dates</b> .....	vii
-------------------------------------	-----

## Additional Information

How to Contact Altera .....	Info-1
Typographic Conventions .....	Info-1

## Section I. Transceivers

### Chapter 1. Cyclone IV Transceivers Architecture

Transceiver Architecture .....	1-2
Architectural Overview .....	1-4
Transmitter Channel Datapath .....	1-5
TX Phase Compensation FIFO .....	1-5
Byte Serializer .....	1-5
8B/10B Encoder .....	1-6
Miscellaneous Transmitter PCS Features .....	1-8
Serializer .....	1-9
Transmitter Output Buffer .....	1-10
Receiver Channel Datapath .....	1-11
Receiver Input Buffer .....	1-11
Clock Data Recovery .....	1-15
Automatic Lock Mode .....	1-15
Manual Lock Mode .....	1-16
Deserializer .....	1-16
Word Aligner .....	1-17
Deskew FIFO .....	1-22
Rate Match FIFO .....	1-23
8B/10B Decoder .....	1-23
Byte Deserializer .....	1-24
Byte Ordering .....	1-24
RX Phase Compensation FIFO .....	1-25
Miscellaneous Receiver PCS Feature .....	1-25
Transceiver Clocking Architecture .....	1-26
Input Reference Clocking .....	1-27
Transceiver Channel Datapath Clocking .....	1-29
Non-Bonded Channel Configuration .....	1-31
Bonded Channel Configuration .....	1-37
FPGA Fabric-Transceiver Interface Clocking .....	1-43
Calibration Block .....	1-45
PCI-Express Hard IP Block .....	1-46
Transceiver Functional Modes .....	1-47
Basic Mode .....	1-48
Rate Match FIFO Operation in Basic Mode .....	1-50
Additional Options in Basic Mode .....	1-50
PCI Express (PIPE) Mode .....	1-52
PIPE Interface .....	1-54
Receiver Detection Circuitry .....	1-54
Electrical Idle Control .....	1-55

Signal Detect at Receiver	1-56
Lane Synchronization	1-56
Clock Rate Compensation	1-56
Low-Latency Synchronous PCIe	1-57
Fast Recovery from P0s State	1-57
Electrical Idle Inference	1-57
Compliance Pattern Transmission	1-58
Reset Requirement	1-58
GIGE Mode	1-59
Running Disparity Preservation with Idle Ordered Set	1-62
Lane Synchronization	1-62
Clock Frequency Compensation	1-63
Serial RapidIO Mode	1-64
Lane Synchronization	1-66
Clock Frequency Compensation	1-67
XAUI Mode	1-67
XGMII and PCS Code Conversions	1-70
Channel Deskewing	1-71
Lane Synchronization	1-72
Clock Rate Compensation	1-73
Deterministic Latency Mode	1-73
Registered Mode Phase Compensation FIFO	1-75
Receive Bit-Slip Indication	1-76
Transmit Bit-Slip Control	1-76
PLL PFD feedback	1-76
SDI Mode	1-76
Loopback	1-78
Reverse Parallel Loopback	1-79
Serial Loopback	1-79
Reverse Serial Loopback	1-80
Self Test Modes	1-81
BIST	1-82
PRBS	1-83
Transceiver Top-Level Port Lists	1-85
Document Revision History	1-93

## Chapter 2. Cyclone IV Reset Control and Power Down

User Reset and Power-Down Signals	2-2
Blocks Affected by the Reset and Power-Down Signals	2-3
Transceiver Reset Sequences	2-4
All Supported Functional Modes Except the PCIe Functional Mode	2-6
Bonded Channel Configuration	2-6
Non-Bonded Channel Configuration	2-10
Reset Sequence in Loss of Link Conditions	2-15
PCIe Functional Mode	2-17
PCIe Reset Sequence	2-17
PCIe Initialization/Compliance Phase	2-18
PCIe Normal Phase	2-18
Dynamic Reconfiguration Reset Sequences	2-19
Reset Sequence in PLL Reconfiguration Mode	2-19
Reset Sequence in Channel Reconfiguration Mode	2-20
Power Down	2-21
Simulation Requirements	2-22
Reference Information	2-23

---

Document Revision History .....	2–24
---------------------------------	------

### **Chapter 3. Cyclone IV Dynamic Reconfiguration**

Glossary of Terms .....	3–1
Dynamic Reconfiguration Controller Architecture .....	3–2
Dynamic Reconfiguration Controller Port List .....	3–4
Offset Cancellation Feature .....	3–10
Functional Simulation of the Offset Cancellation Process .....	3–12
Dynamic Reconfiguration Modes .....	3–12
PMA Controls Reconfiguration Mode .....	3–13
Method 1: Using logical_channel_address to Reconfigure Specific Transceiver Channels .....	3–14
Method 2: Writing the Same Control Signals to Control All the Transceiver Channels .....	3–16
Method 3: Writing Different Control Signals for all the Transceiver Channels at the Same Time ..	3–19
Transceiver Channel Reconfiguration Mode .....	3–21
Channel Interface Reconfiguration Mode .....	3–22
Data Rate Reconfiguration Mode Using RX Local Divider .....	3–26
Control and Status Signals for Channel Reconfiguration .....	3–27
PLL Reconfiguration Mode .....	3–33
Error Indication During Dynamic Reconfiguration .....	3–36
Functional Simulation of the Dynamic Reconfiguration Process .....	3–37
Document Revision History .....	3–37



---

The chapters in this document, Cyclone IV Device Handbook, were revised on the following dates. Where chapters or groups of chapters are available separately, part numbers are listed.

- Chapter 1. Cyclone IV Transceivers Architecture  
Revised: *February 2015*  
Part Number: *CYIV-52001-3.7*
  
- Chapter 2. Cyclone IV Reset Control and Power Down  
Revised: *September 2014*  
Part Number: *CYIV-52002-1.4*
  
- Chapter 3. Cyclone IV Dynamic Reconfiguration  
Revised: *November 2011*  
Part Number: *CYIV-52003-2.1*



This chapter provides additional information about the document and Altera.

## About this Handbook

This handbook provides comprehensive information about the Altera® Cyclone® IV family of devices.

## How to Contact Altera

To locate the most up-to-date information about Altera products, refer to the following table.

Contact <sup>(1)</sup>	Contact Method	Address
Technical support	Website	<a href="http://www.altera.com/support">www.altera.com/support</a>
Technical training	Website	<a href="http://www.altera.com/training">www.altera.com/training</a>
	Email	<a href="mailto:custrain@altera.com">custrain@altera.com</a>
Product literature	Website	<a href="http://www.altera.com/literature">www.altera.com/literature</a>
Nontechnical support (general) (software licensing)	Email	<a href="mailto:nacomp@altera.com">nacomp@altera.com</a>
	Email	<a href="mailto:authorization@altera.com">authorization@altera.com</a>









**Note to Table:**

(1) You can also contact your local Altera sales office or sales representative.

## Typographic Conventions

The following table shows the typographic conventions this document uses.

Visual Cue	Meaning
<b>Bold Type with Initial Capital Letters</b>	Indicate command names, dialog box titles, dialog box options, and other GUI labels. For example, <b>Save As</b> dialog box. For GUI elements, capitalization matches the GUI.
<b>bold type</b>	Indicates directory names, project names, disk drive names, file names, file name extensions, software utility names, and GUI labels. For example, <code>\qdesigns</code> directory, <b>D:</b> drive, and <code>chiptrip.gdf</code> file.
<i>Italic Type with Initial Capital Letters</i>	Indicate document titles. For example, <i>Stratix IV Design Guidelines</i> .
<i>italic type</i>	Indicates variables. For example, $n + 1$ . Variable names are enclosed in angle brackets (< >). For example, <code>&lt;file name&gt;</code> and <code>&lt;project name&gt;.pof</code> file.
Initial Capital Letters	Indicate keyboard keys and menu names. For example, the Delete key and the Options menu.
“Subheading Title”	Quotation marks indicate references to sections in a document and titles of Quartus II Help topics. For example, “Typographic Conventions.”

Visual Cue	Meaning
Courier type	<p>Indicates signal, port, register, bit, block, and primitive names. For example, <code>data1</code>, <code>tdi</code>, and <code>input</code>. The suffix <code>n</code> denotes an active-low signal. For example, <code>resetn</code>.</p> <p>Indicates command line commands and anything that must be typed exactly as it appears. For example, <code>c:\qdesigns\tutorial\chiptrip.gdf</code>.</p> <p>Also indicates sections of an actual file, such as a Report File, references to parts of files (for example, the AHDL keyword <code>SUBDESIGN</code>), and logic function names (for example, <code>TRI</code>).</p>
	An angled arrow instructs you to press the Enter key.
1., 2., 3., and a., b., c., and so on	Numbered steps indicate a list of items when the sequence of the items is important, such as the steps listed in a procedure.
	Bullets indicate a list of items when the sequence of the items is not important.
	The hand points to information that requires special attention.
	The question mark directs you to a software help system with related information.
	The feet direct you to another document or website with related information.
	The multimedia icon directs you to a related multimedia presentation.
	A caution calls attention to a condition or possible situation that can damage or destroy the product or your work.
	A warning calls attention to a condition or possible situation that can cause you injury.
	The envelope links to the <a href="#">Email Subscription Management Center</a> page of the Altera website, where you can sign up to receive update notifications for Altera documents.

This section provides a complete overview of all features relating to the Cyclone<sup>®</sup> IV device transceivers. This section includes the following chapters:

- [Chapter 1, Cyclone IV Transceivers Architecture](#)
- [Chapter 2, Cyclone IV Reset Control and Power Down](#)
- [Chapter 3, Cyclone IV Dynamic Reconfiguration](#)

### Revision History

Refer to the chapter for its own specific revision history. For information about when the chapter was updated, refer to the Chapter Revision Dates section, which appears in the complete handbook.



Cyclone® IV GX devices include up to eight full-duplex transceivers at serial data rates between 600 Mbps and 3.125 Gbps in a low-cost FPGA. [Table 1–1](#) lists the supported Cyclone IV GX transceiver channel serial protocols.

**Table 1–1. Serial Protocols Supported by the Cyclone IV GX Transceiver Channels**

Protocol	Data Rate (Gbps)	F324 and smaller packages	F484 and larger packages
PCI Express® (PCIe®) <sup>(1)</sup>	2.5	✓	✓
Gbps Ethernet (GbE)	1.25	✓	✓
Common Public Radio Interface (CPRI)	0.6144, 1.2288, 2.4576, and 3.072	✓ <sup>(2)</sup>	✓
OBSAI	0.768, 1.536, and 3.072	✓ <sup>(2)</sup>	✓
XAUI	3.125	—	✓
Serial digital interface (SDI)	HD-SDI at 1.485 and 1.4835	✓	✓
	3G-SDI at 2.97 and 2.967	—	
Serial RapidIO® (SRIO)	1.25, 2.5, and 3.125	—	✓
Serial Advanced Technology Attachment (SATA)	1.5 and 3.0	—	✓
V-by-one	3.125	—	✓
Display Port	1.62 and 2.7	—	✓

**Notes to Table 1–1:**

- (1) Provides the physical interface for PCI Express (PIPE)-compliant interface that supports Gen1 ×1, ×2, and ×4 initial lane width configurations. When implementing ×1 or ×2 interface, remaining channels in the transceiver block are available to implement other protocols.
- (2) Supports data rates up to 2.5 Gbps only.

You can implement these protocols through the ALTGX MegaWizard™ Plug-In Manager, which also offers the highly flexible Basic functional mode to implement proprietary serial protocols at the following serial data rates:

- 600 Mbps to 2.5 Gbps for devices in F324 and smaller packages
- 600 Mbps to 3.125 Gbps for devices in F484 and larger packages

For descriptions of the ports available when instantiating a transceiver using the ALTGX megafunction, refer to “[Transceiver Top-Level Port Lists](#)” on page 1–85.

For more information about Cyclone IV transceivers that run at ≥2.97 Gbps data rate, refer to the [Cyclone IV Device Family Pin Connection Guidelines](#).

 The Cyclone IV GX device includes a hard intellectual property (IP) implementation of the PCIe MegaCore® functions, supporting Gen1 ×1, ×2, and ×4 initial lane widths configured in the root port or endpoint mode. For more information, refer to “PCI-Express Hard IP Block” on page 1-46.

## Transceiver Architecture

Cyclone IV GX devices offer either one or two transceiver blocks per device, depending on the package. Each block consists of four full-duplex (transmitter and receiver) channels, located on the left side of the device (in a die-top view). [Figure 1-1](#) and [Figure 1-2](#) show the die-top view of the transceiver block and related resource locations in Cyclone IV GX devices.

**Figure 1-1. F324 and Smaller Packages with Transceiver Channels for Cyclone IV GX Devices**

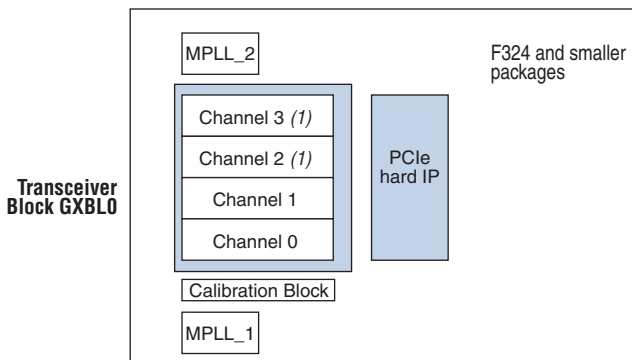

**Note to Figure 1-1:**

(1) Channel 2 and Channel 3 are not available in the F169 and smaller packages.

Figure 1–2. F484 and Larger Packages with Transceiver Channels for Cyclone IV GX Devices

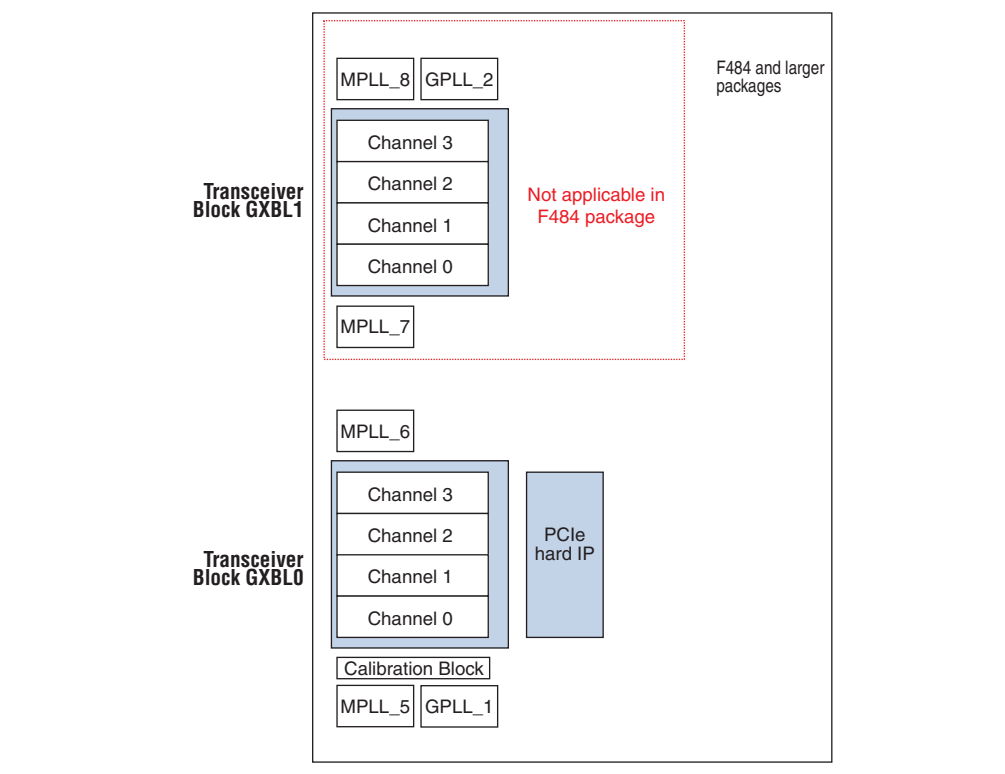

For more information about the transceiver architecture, refer to the following sections:

- “Architectural Overview” on page 1–4
- “Transmitter Channel Datapath” on page 1–5
- “Receiver Channel Datapath” on page 1–11
- “Transceiver Clocking Architecture” on page 1–26
- “Transceiver Channel Datapath Clocking” on page 1–29
- “FPGA Fabric-Transceiver Interface Clocking” on page 1–43
- “Calibration Block” on page 1–45
- “PCI-Express Hard IP Block” on page 1–46

## Architectural Overview

Figure 1-3 shows the Cyclone IV GX transceiver channel datapath.

**Figure 1-3. Transceiver Channel Datapath for Cyclone IV GX Devices**

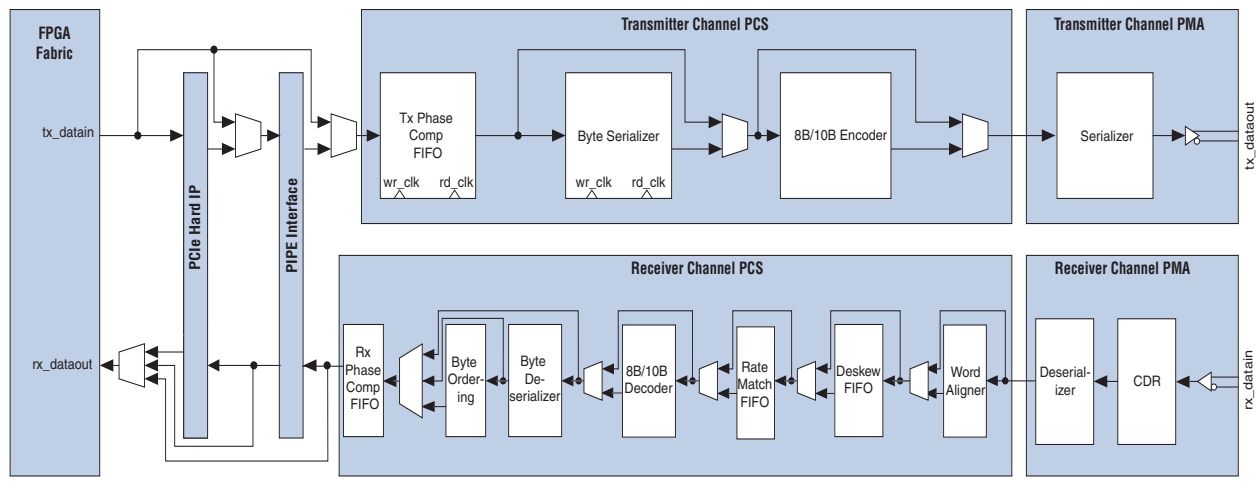

Each transceiver channel consists of a transmitter and a receiver datapath. Each datapath is further structured into the following:

- Physical media attachment (PMA)—includes analog circuitry for I/O buffers, clock data recovery (CDR), serializer/deserializer (SERDES), and programmable pre-emphasis and equalization to optimize serial data channel performance.
- Physical coding sublayer (PCS)—includes hard logic implementation of digital functionality within the transceiver that is compliant with supported protocols.

Outbound parallel data from the FPGA fabric flows through the transmitter PCS and PMA, is transmitted as serial data. Received inbound serial data flows through the receiver PMA and PCS into the FPGA fabric. The transceiver supports the following interface widths:

- FPGA fabric-transceiver PCS—8, 10, 16, or 20 bits
- PMA-PCS—8 or 10 bits

 The transceiver channel interfaces through the PIPE when configured for PCIe protocol implementation. The PIPE is compliant with version 2.00 of the *PHY Interface for the PCI Express Architecture* specification.

## Transmitter Channel Datapath

The following sections describe the Cyclone IV GX transmitter channel datapath architecture as shown in Figure 1-3:

- TX Phase Compensation FIFO
- Byte Serializer
- 8B/10B Encoder
- Serializer
- Transmitter Output Buffer

### TX Phase Compensation FIFO

The TX phase compensation FIFO compensates for the phase difference between the low-speed parallel clock and the FPGA fabric interface clock, when interfacing the transmitter channel to the FPGA fabric (directly or through the PIPE and PCIe hard IP). The FIFO is four words deep, with latency between two to three parallel clock cycles. Figure 1-4 shows the TX phase compensation FIFO block diagram.

**Figure 1-4. TX Phase Compensation FIFO Block Diagram**

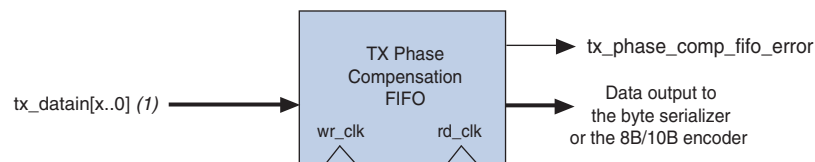

**Note to Figure 1-4:**

(1) The x refers to the supported 8-, 10-, 16-, or 20-bits transceiver channel width.

 The FIFO can operate in registered mode, contributing to only one parallel clock cycle of latency in Deterministic Latency functional mode. For more information, refer to “[Deterministic Latency Mode](#)” on page 1-73.

 For more information about FIFO clocking, refer to “[FPGA Fabric-Transceiver Interface Clocking](#)” on page 1-43.

### Byte Serializer

The byte serializer divides the input datapath width by two to allow transmitter channel operation at higher data rates while meeting the maximum FPGA fabric frequency limit. This module is required in configurations that exceed the maximum FPGA fabric-transceiver interface clock frequency limit and optional in configurations that do not.

 For the FPGA fabric-transceiver interface frequency specifications, refer to the [Cyclone IV Device Data Sheet](#).

For example, when operating an EP4CGX150 transmitter channel at 3.125 Gbps without byte serializer, the FPGA fabric frequency is 312.5 MHz (3.125 Gbps/10). This implementation violates the frequency limit and is not supported. Channel operation at 3.125 Gbps is supported when byte serializer is used, where the FPGA fabric frequency is 156.25 MHz (3.125 Gbps/20).

The byte serializer forwards the least significant byte first, followed by the most significant byte.

## 8B/10B Encoder

The optional 8B/10B encoder generates 10-bit code groups with proper disparity from the 8-bit data and 1-bit control identifier as shown in [Figure 1-5](#).

 The encoder is compliant with Clause 36 of the *IEEE 802.3 Specification*.

**Figure 1-5. 8B/10B Encoder Block Diagram**

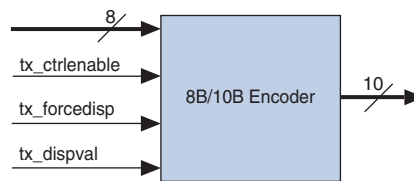

The 1-bit control identifier (`tx_ctrlenable`) port controls the 8-bit translation to either a 10-bit data word ( $Dx.y$ ) or a 10-bit control word ( $Kx.y$ ). [Figure 1-6](#) shows the 8B/10B encoding operation with the `tx_ctrlenable` port, where the second 8'hBC data is encoded as a control word when `tx_ctrlenable` port is asserted, while the rest of the data is encoded as a data word.

**Figure 1-6. Control and Data Word Encoding with the 8B/10B Encoder**

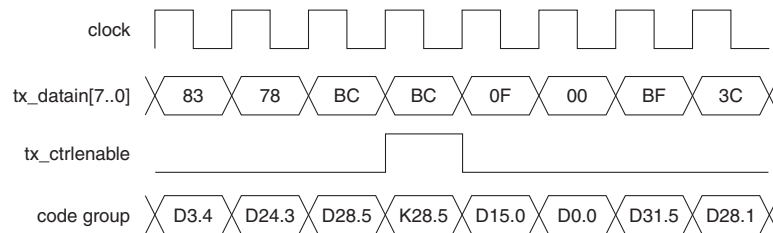

 The IEEE 802.3 8B/10B encoder specification identifies only a set of 8-bit characters for which the `tx_ctrlenable` port should be asserted. If you assert `tx_ctrlenable` port for any other set of characters, the 8B/10B encoder might encode the output 10-bit code as an invalid code (it does not map to a valid  $Dx.y$  or  $Kx.y$  code), or an unintended valid  $Dx.y$  code, depending on the value entered. It is possible for a downstream 8B/10B decoder to decode an invalid control word into a valid  $Dx.y$  code without asserting any code error flags. Altera recommends not to assert `tx_ctrlenable` port for unsupported 8-bit characters.

The following describes the 8B/10B encoder behavior in reset condition (as shown in Figure 1-7):

- During reset, the 8B/10B encoder ignores the inputs (tx\_datain and tx\_ctrlenable ports) from the FPGA fabric and outputs the K28.5 pattern from the RD- column continuously until the tx\_digitalreset port is deasserted.
- Upon deassertion of the tx\_digitalreset port, the 8B/10B encoder starts with a negative disparity and transmits three K28.5 code groups for synchronization before it starts encoding and transmitting data on its output.
- Due to some pipelining of the transmitter PCS, some "don't cares" (10'hxxx) are sent before the three synchronizing K28.5 code groups.

**Figure 1-7. 8B/10B Encoder Behavior in Reset Condition**

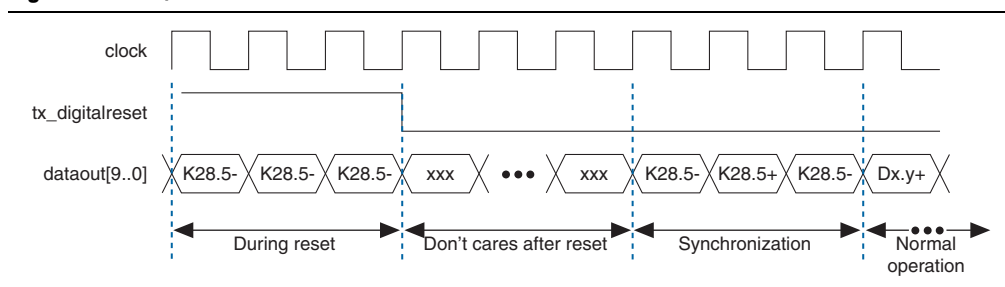

The encoder supports forcing the running disparity to either positive or negative disparity with tx\_forcedisp and tx\_dispvall ports. Figure 1-8 shows an example of tx\_forcedisp and tx\_dispvall port use, where data is shown in hexadecimal radix.

**Figure 1-8. Force Running Disparity Operation**

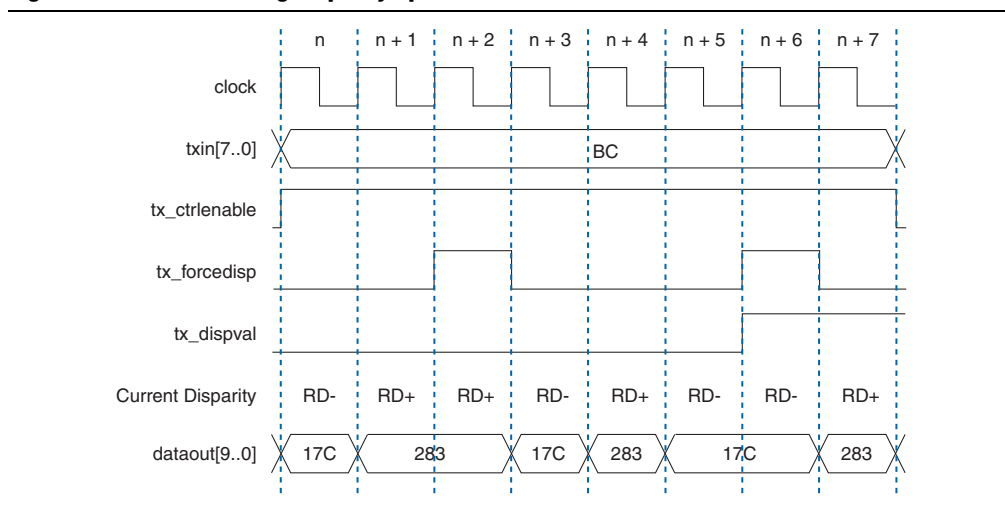

In this example, a series of K28.5 code groups are continuously sent. The stream alternates between a positive disparity K28.5 (RD+) and a negative disparity K28.5 (RD-) to maintain a neutral overall disparity. The current running disparity at time  $n + 1$  indicates that the K28.5 in time  $n + 2$  should be encoded with a negative disparity. Because tx\_forcedisp is high at time  $n + 2$ , and tx\_dispvall is low, the K28.5

at time  $n + 2$  is encoded as a positive disparity code group. In the same example, the current running disparity at time  $n + 5$  indicates that the K28.5 in time  $n + 6$  should be encoded with a positive disparity. Because `tx_forcedisp` is high at time  $n + 6$ , and `tx_dispval` is high, the K28.5 at time  $n + 6$  is encoded as a negative disparity code group.

## Miscellaneous Transmitter PCS Features

The transmitter PCS supports the following additional features:

- Polarity inversion—corrects accidentally swapped positive and negative signals from the serial differential link during board layout by inverting the polarity of each bit. An optional `tx_invpolarity` port is available to dynamically invert the polarity of every bit of the 8-bit or 10-bit input data to the serializer in the transmitter datapath. Figure 1-9 shows the transmitter polarity inversion feature.

**Figure 1-9. Transmitter Polarity Inversion**

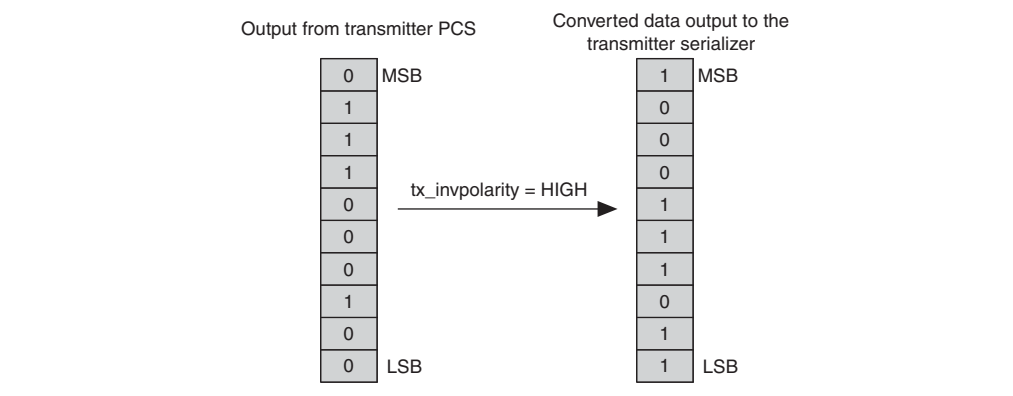

`tx_invpolarity` is a dynamic signal and might cause initial disparity errors at the receiver of an 8B/10B encoded link. The downstream system must be able to tolerate these disparity errors.

- Bit reversal—reverses the transmit bit order from LSB-to-MSB (default) to MSB-to-LSB at the input to the serializer. For example, input data to serializer  $D[7..0]$  is rewired to  $D[0..7]$  for 8-bit data width, and  $D[9..0]$  is rewired to  $D[0..9]$  for 10-bit data width. Figure 1-10 shows the transmitter bit reversal feature.

**Figure 1-10. Transmitter Bit Reversal Operation in Basic Single-Width Mode**

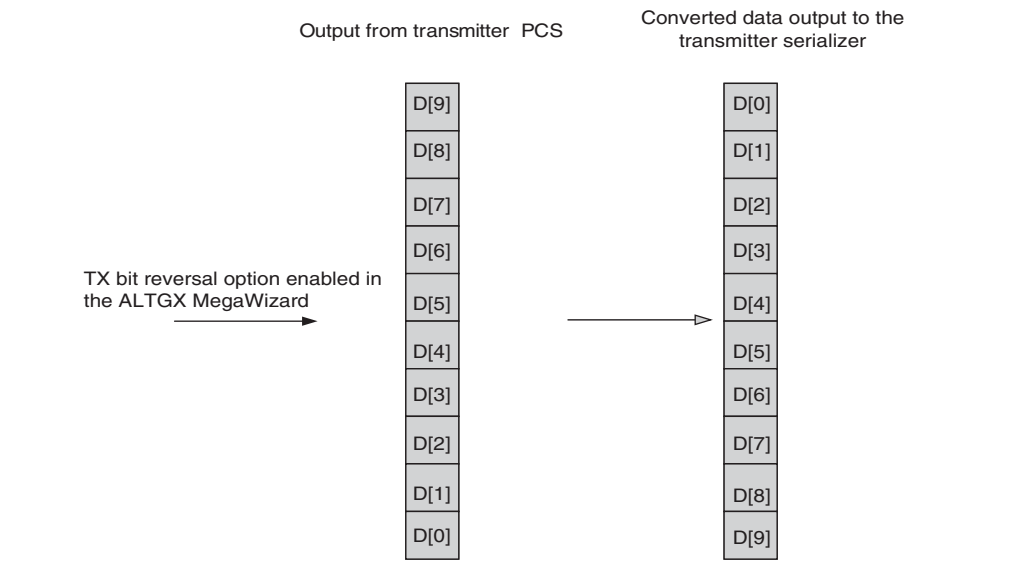

- Input bit-flip—reverses the bit order at a byte level at the input of the transmitter phase compensation FIFO. For example, if the 16-bit parallel transmitter data at the `tx_datain` port is '10111100 10101101' (16'hBCAD), selecting this option reverses the input data to the transmitter phase compensation FIFO to '00111101 10110101' (16'h3DB5).
- Bit-slip control—delays the data transmission by a number of specified bits to the serializer with the `tx_bitslipboundaryselect` port. For usage details, refer to the “Transmit Bit-Slip Control” on page 1-76.

## Serializer

The serializer converts the low-speed parallel 8-bit or 10-bit data from the transmitter PCS to high-speed serial data for the transmitter output buffer. The serializer operates with a high-speed clock at half of the serial data rate. The serializer transmission sequence is LSB to MSB.

## Transmitter Output Buffer

Figure 1-11 shows the transmitter output buffer block diagram.

**Figure 1-11. Transmitter Output Buffer Block Diagram**

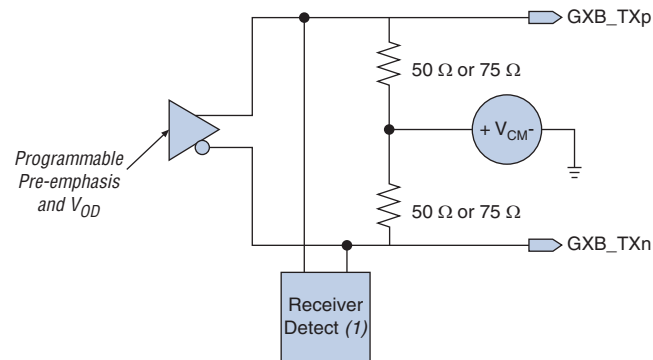

**Note to Figure 1-11:**

- (1) Receiver detect function is specific for PCIe protocol implementation only. For more information, refer to “PCI Express (PIPE) Mode” on page 1-52.

The Cyclone IV GX transmitter output buffers support the 1.5-V PCML I/O standard and are powered by VCCH\_GXB power pins with 2.5-V supply. The 2.5-V supply on VCCH\_GXB pins are regulated internally to 1.5-V for the transmitter output buffers. The transmitter output buffers support the following additional features:

- Programmable differential output voltage ( $V_{OD}$ )—customizes the  $V_{OD}$  up to 1200 mV to handle different trace lengths, various backplanes, and various receiver requirements.
- Programmable pre-emphasis—boosts high-frequency components in the transmitted signal to maximize the data eye opening at the far-end. The high-frequency components might be attenuated in the transmission media due to data-dependent jitter and intersymbol interference (ISI) effects. The requirement for pre-emphasis increases as the data rates through legacy backplanes increase.
- Programmable differential on-chip termination (OCT)—provides calibrated OCT at differential 100  $\Omega$  or 150  $\Omega$  with on-chip transmitter common mode voltage ( $V_{CM}$ ) at 0.65 V.  $V_{CM}$  is tri-stated when you disable the OCT to use external termination.

 Disable OCT to use external termination if the link requires a 85  $\Omega$  termination, such as when you are interfacing with certain PCIe Gen1 or Gen2 capable devices.

 The Cyclone IV GX transmitter output buffers are current-mode drivers. The resulting  $V_{OD}$  voltage is therefore a function of the transmitter termination value. For lists of supported  $V_{OD}$  settings, refer to the *Cyclone IV Device Data Sheet*.

## Receiver Channel Datapath

The following sections describe the Cyclone IV GX receiver channel datapath architecture as shown in Figure 1-3 on page 1-4:

- “Receiver Input Buffer” on page 1-11
- “Clock Data Recovery” on page 1-15
- “Deserializer” on page 1-16
- “Word Aligner” on page 1-17
- “Deskew FIFO” on page 1-22
- “Rate Match FIFO” on page 1-23
- “8B/10B Decoder” on page 1-23
- “Byte Deserializer” on page 1-24
- “Byte Ordering” on page 1-24
- “RX Phase Compensation FIFO” on page 1-25

### Receiver Input Buffer

Table 1-2 lists the electrical features supported by the Cyclone IV GX receiver input buffer.

**Table 1-2. Electrical Features Supported by the Receiver Input Buffer**

I/O Standard	Programmable Common Mode Voltage (V)	Coupling
1.4-V PCML	0.82	AC, DC
1.5-V PCML	0.82	AC, DC
2.5-V PCML	0.82	AC
LVPECL	0.82	AC
LVDS	0.82	AC, DC <sup>(1)</sup>

**Note to Table 1-2:**

(1) DC coupling is supported for LVDS with lower on-chip common mode voltage of 0.82 V.

The high-speed serial link can be AC- or DC-coupled, depending on the serial protocol implementation. In an AC-coupled link, the AC-coupling capacitor blocks the transmitter DC common mode voltage as shown in Figure 1-12. Receiver OCT and on-chip biasing circuitry automatically restores the common mode voltage. The biasing circuitry is also enabled by enabling OCT. If you disable the OCT, then you must externally terminate and bias the receiver. AC-coupled links are required for PCIe, GbE, Serial RapidIO, SDI, XAUI, SATA, V-by-One and Display Port protocols.

**Figure 1-12. AC-Coupled Link with OCT**

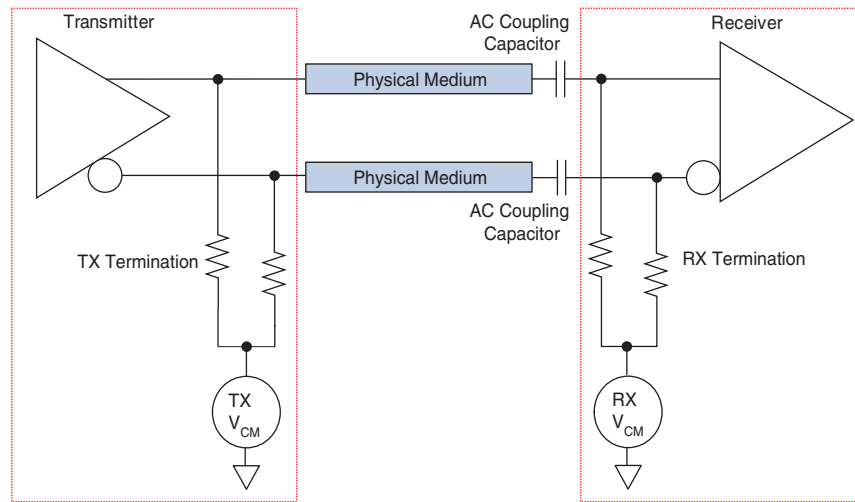

In a DC-coupled link, the transmitter DC common mode voltage is seen unblocked at the receiver input buffer as shown in Figure 1-13. The link common mode voltage depends on the transmitter common mode voltage and the receiver common mode voltage. When using the receiver OCT and on-chip biasing circuitry in a DC coupled link, you must ensure the transmitter common mode voltage is compatible with the receiver common mode requirements. If you disable the OCT, you must terminate and bias the receiver externally and ensure compatibility between the transmitter and the receiver common mode voltage.

**Figure 1-13. DC-Coupled Link with OCT**

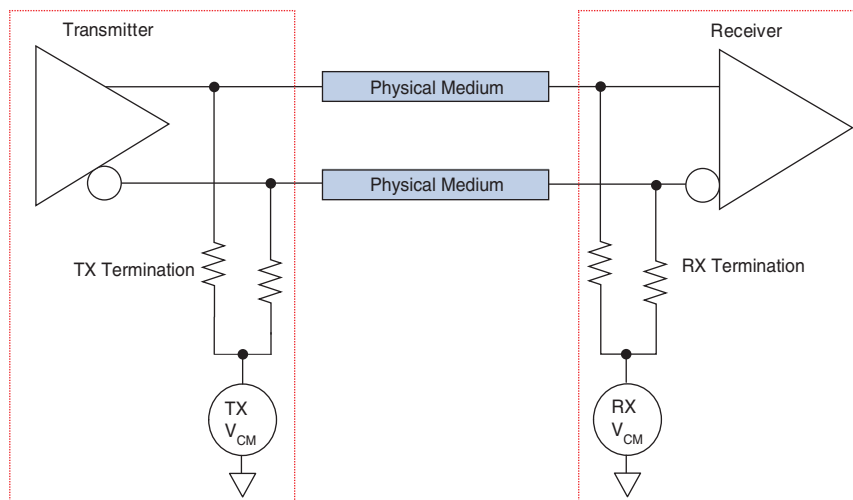
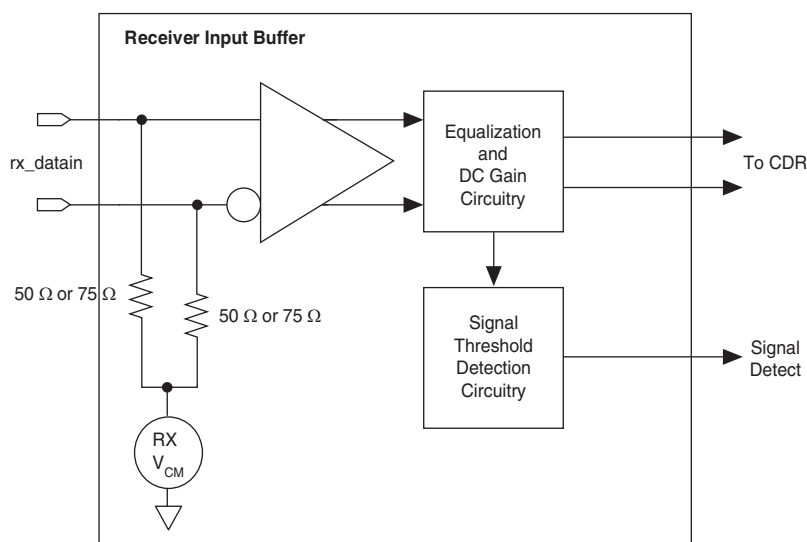



Figure 1-14 shows the receiver input buffer block diagram.

**Figure 1-14. Receiver Input Buffer Block Diagram**



The receiver input buffers support the following features:

- Programmable equalization—boosts the high-frequency gain of the incoming signal up to 7 dB. This compensates for the low-pass filter effects of the transmission media. The amount of high-frequency gain required depends on the loss characteristics of the physical medium.
- Programmable DC gain—provides equal boost to incoming signal across the frequency spectrum with DC gain settings up to 6 dB.
- Programmable differential OCT—provides calibrated OCT at 100  $\Omega$  or 150  $\Omega$  with on-chip receiver common mode voltage at 0.82 V. The common mode voltage is tri-stated when you disable the OCT to use external termination.
- Offset cancellation—corrects the analog offset voltages that might exist from process variations between the positive and negative differential signals in the equalizer stage and CDR circuit.
- Signal detection—detects if the signal level present at the receiver input buffer is higher than the threshold with a built-in signal threshold detection circuitry. The circuitry has a hysteresis response that filters out any high-frequency ringing caused by ISI effects or high-frequency losses in the transmission medium. Detection is indicated by the assertion of the `rx_signaldetect` signal. Signal detection is only supported when 8B/10B encoder/decoder block is enabled. When not supported, the `rx_signaldetect` signal is forced high, bypassing the signal detection function.

 Disable OCT to use external termination if the link requires a 85  $\Omega$  termination, such as when you are interfacing with certain PCIe Gen1 or Gen2 capable devices.

 For specifications on programmable equalization and DC gain settings, refer to the [Cyclone IV Device Data Sheet](#).

## Clock Data Recovery

Each receiver channel has an independent CDR unit to recover the clock from the incoming serial data stream. The high-speed recovered clock is used to clock the deserializer for serial-to-parallel conversion of the received input data, and low-speed recovered clock to clock the receiver PCS blocks. Figure 1-15 illustrates the CDR unit block diagram.

**Figure 1-15. CDR Unit Block Diagram**

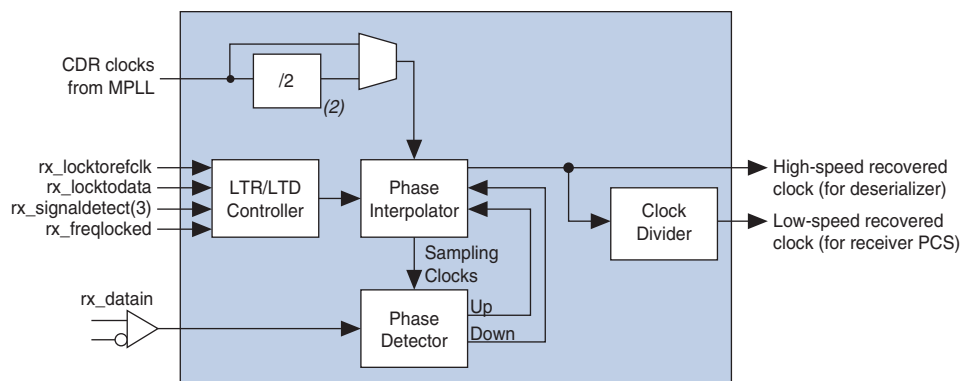

**Notes to Figure 1-15:**

- (1) Optional RX local divider for CDR clocks from multipurpose PLL is only available in each CDR unit for EP4CGX30 (F484 package), EP4CGX50, and EP4CGX75 devices. This block is used with the transceiver dynamic reconfiguration feature. For more information, refer to the *Cyclone IV Dynamic Reconfiguration* chapter and *AN 609: Implementing Dynamic Reconfiguration in Cyclone IV GX Devices*.
- (2) CDR state transition in automatic lock mode is not dependent on `rx_signaldetect` signal, except when configured in PCI Express (PIPE) mode only.

Each CDR unit gets the reference clock from one of the two multipurpose phase-locked loops (PLLs) adjacent to the transceiver block. The CDR works by tracking the incoming data with a phase detector and finding the optimum sampling clock phase from the phase interpolator unit. The CDR operations are controlled by the LTR/LTD controller block, where the CDR may operate in the following states:

- Lock-to-reference (LTR) state—phase detector disabled and CDR ignores incoming data
- Lock-to-data (LTD) state—phase detector enabled and CDR tracks incoming data to find the optimum sampling clock phase

State transitions are supported with automatic lock mode and manual lock mode.

### Automatic Lock Mode

Upon receiver power-up and reset cycle, the CDR is put into LTR state. Transition to the LTD state is performed automatically when both of the following conditions are met:

- Signal detection circuitry indicates the presence of valid signal levels at the receiver input buffer. This condition is valid for PCI Express (PIPE) mode only. CDR transitions are not dependent on signal detection circuitry in other modes.
- The recovered clock is within the configured part per million (ppm) frequency threshold setting with respect to the CDR clocks from multipurpose PLL.

Actual lock time depends on the transition density of the incoming data and the ppm difference between the receiver input reference clock and the upstream transmitter reference clock.

Transition from the LTD state to the LTR state occurs when either of the following conditions is met:

- Signal detection circuitry indicates the absence of valid signal levels at the receiver input buffer. This condition is valid for PCI Express (PIPE) mode only. CDR transitions are not dependent on signal detection circuitry in other modes.
- The recovered clock is not within the configured ppm frequency threshold setting with respect to CDR clocks from multipurpose PLLs.

In automatic lock mode, the switch from LTR to LTD states is indicated by the assertion of the `rx_freqlocked` signal and the switch from LTD to LTR states indicated by the de-assertion of the `rx_freqlocked` signal.

## Manual Lock Mode

State transitions are controlled manually by using `rx_locktorefclk` and `rx_locktodata` ports. The LTR/LTD controller sets the CDR state depending on the logic level on the `rx_locktorefclk` and `rx_locktodata` ports. This mode provides the flexibility to control the CDR for a reduced lock time compared to the automatic lock mode. In automatic lock mode, the LTR/LTD controller relies on the ppm detector and the phase relationship detector to set the CDR in LTR or LTD mode. The ppm detector and phase relationship detector reaction times can be too long for some applications that require faster CDR lock time.

In manual lock mode, the `rx_freqlocked` signal is asserted when the CDR is in LTD state and de-asserted when CDR is in LTR state. For descriptions of `rx_locktorefclk` and `rx_locktodata` port controls, refer to [Table 1-27 on page 1-87](#).



If you do not enable the optional `rx_locktorefclk` and `rx_locktodata` ports, the Quartus II software automatically configures the LTR/LTD controller in automatic lock mode.



The recommended transceiver reset sequence varies depending on the CDR lock mode. For more information about the reset sequence recommendations, refer to the [Reset Control and Power Down for Cyclone IV GX Devices](#) chapter.

## Deserializer

The deserializer converts received serial data from the receiver input buffer to parallel 8- or 10-bit data. Serial data is assumed to be received from the LSB to the MSB. The deserializer operates with the high-speed recovered clock from the CDR with the frequency at half of the serial data rate.

## Word Aligner

Figure 1-16 shows the word aligner block diagram. The word aligner receives parallel data from the deserializer and restores the word boundary based on a pre-defined alignment pattern that must be received during link synchronization. The word aligner supports three operational modes as listed in Table 1-3.

Figure 1-16. Word Aligner Block Diagram

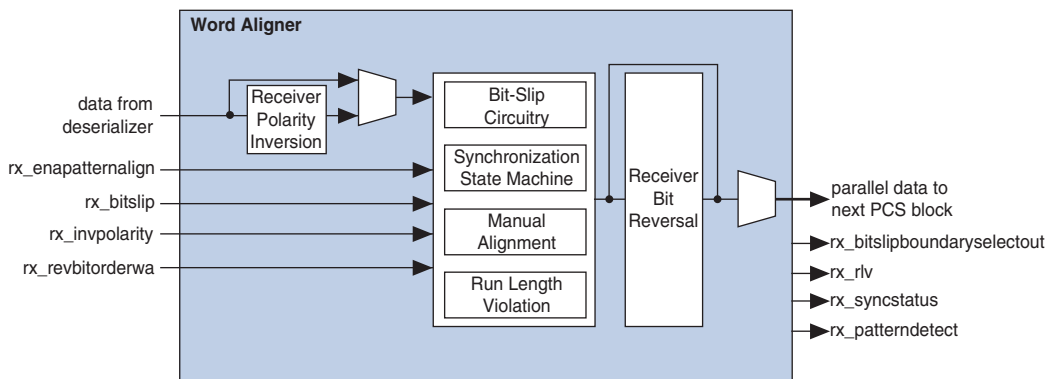

Table 1-3. Word Aligner Modes

Modes	PMA-PCS Interface Widths	Allowed Word Alignment Pattern Lengths
Manual Alignment	8-bit	16 bits
	10-bit	7 or 10 bits
Bit-Slip	8-bit	16 bits
	10-bit	7 or 10 bits
Automatic Synchronization State Machine	10-bit	7 or 10 bits

### Manual Alignment Mode

In manual alignment mode, the `rx_enapatternalign` port controls the word aligner with either an 8- or 10-bit data width setting.

The 8-bit word aligner is edge-sensitive to the `rx_enapatternalign` signal. A rising edge on `rx_enapatternalign` signal after deassertion of the `rx_digitalreset` signal triggers the word aligner to look for the word alignment pattern in the received data stream. It updates the word boundary if it finds the word alignment pattern in a new word boundary. Any word alignment pattern received thereafter in a different word boundary causes the word aligner to re-align to the new word boundary only if there is a rising edge in the `rx_enapatternalign` signal.

The 10-bit word aligner is level-sensitive to the `rx_enapatternalign` signal. The word aligner looks for the programmed 7-bit or 10-bit word alignment pattern or its complement in the received data stream, if the `rx_enapatternalign` signal is held high. It updates the word boundary if it finds the word alignment pattern in a new word boundary. If the `rx_enapatternalign` signal is deasserted, the word aligner maintains the current word boundary even when it receives the word alignment pattern in a new word boundary.

After updating the word boundary, word aligner status signals (`rx_syncstatus` and `rx_patterndetect`) are driven high for one parallel clock cycle synchronous to the most significant byte of the word alignment pattern. The `rx_syncstatus` and `rx_patterndetect` signals have the same latency as the datapath and are forwarded to the FPGA fabric to indicate the word aligner status. Any word alignment pattern received thereafter in the same word boundary causes only the `rx_patterndetect` signal to go high for one clock cycle.

Figure 1-17 shows the manual alignment mode word aligner operation in 10-bit data width mode. In this example, a `/K28.5/` (`10'b010111100`) is specified as the word alignment pattern.

The word aligner aligns to the `/K28.5/` alignment pattern (red) in cycle  $n$  because the `rx_enapatternalign` signal is asserted high. The `rx_syncstatus` signal goes high for one clock cycle indicating alignment to a new word boundary. The `rx_patterndetect` signal also goes high for one clock cycle to indicate initial word alignment.

At time  $n + 1$ , the `rx_enapatternalign` signal is deasserted to instruct the word aligner to lock the current word boundary.

The alignment pattern is detected again (green) in a new word boundary across cycles  $n + 2$  and  $n + 3$ . The word aligner does not align to this new word boundary because the `rx_enapatternalign` signal is held low.

The `/K28.5/` word alignment pattern is detected again (blue) in the current word boundary during cycle  $n + 5$  causing the `rx_patterndetect` signal to go high for one parallel clock cycle.

**Figure 1-17. Word Aligner in 10-bit Manual Alignment Mode**

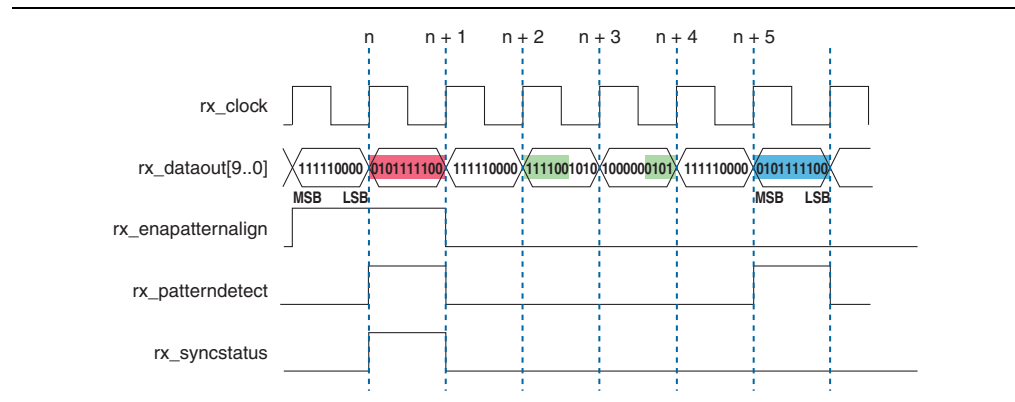

If the word alignment pattern is known to be unique and does not appear between word boundaries, you can hold the `rx_enapatternalign` signal constantly high because there is no possibility of false word alignment. If there is a possibility of the word alignment pattern occurring across word boundaries, you must control the `rx_enapatternalign` signal to lock the word boundary after the desired word alignment is achieved to avoid re-alignment to an incorrect word boundary.

### Bit-Slip Mode

In bit-slip mode, the `rx_bitslip` port controls the word aligner operation. At every rising edge of the `rx_bitslip` signal, the bit-slip circuitry slips one bit into the received data stream, effectively shifting the word boundary by one bit. When the received data after bit-slipping matches the programmed word alignment pattern, the `rx_patterndetect` signal is driven high for one parallel clock cycle.



You can implement a bit-slip controller in the user logic that monitors either the `rx_patterndetect` signal or the receiver data output (`rx_dataout`), and controls the `rx_bitslip` port to achieve word alignment.

Figure 1-18 shows an example of the word aligner configured in bit-slip mode. For this example, consider that `8'b11110000` is received back-to-back and `16'b0000111100011110` is specified as the word alignment pattern. A rising edge on the `rx_bitslip` signal at time  $n + 1$  slips a single bit 0 at the MSB position, forcing the `rx_dataout` to `8'b01111000`. Another rising edge on the `rx_bitslip` signal at time  $n + 5$  forces `rx_dataout` to `8'b00111100`. Another rising edge on the `rx_bitslip` signal at time  $n + 9$  forces `rx_dataout` to `8'b00011110`. Another rising edge on the `rx_bitslip` signal at time  $n + 13$  forces the `rx_dataout` to `8'b00001111`. At this instance, `rx_dataout` in cycles  $n + 12$  and  $n + 13$  is `8'b00011110` and `8'b00001111`, respectively, which matches the specified 16-bit alignment pattern `16'b0000111100011110`. This results in the assertion of the `rx_patterndetect` signal.

**Figure 1-18. Word Aligner Configured in Bit-Slip Mode**

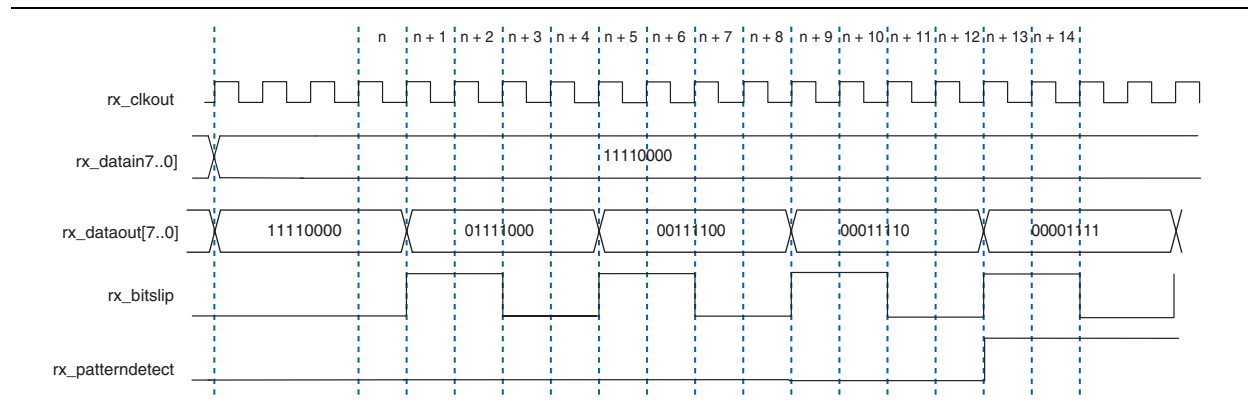

### Automatic Synchronization State Machine Mode

In automatic synchronization state machine mode, the word aligner achieves synchronization after receiving a specific number of synchronization code groups, and falls out of synchronization after receiving a specific number of erroneous code groups. This mode provides hysteresis during link synchronization, which is required by protocols such as PCIe, GbE, XAUI, and Serial RapidIO.



This mode is only supported using the 8B/10B encoded data with 10-bit input to the word aligner.

Table 1-4 lists the synchronization state machine parameters for the word aligner in this mode.

**Table 1-4. Synchronization State Machine Parameters**

Parameter	Allowed Values
Number of erroneous code groups received to lose synchronization	1-64
Number of continuous good code groups received to reduce the error count by one	1-256

After deassertion of the `rx_digitalreset` signal in automatic synchronization state machine mode, the word aligner starts looking for the synchronization code groups, word alignment pattern or its complement in the received data stream. When the programmed number of valid synchronization code groups or ordered sets are received, the `rx_syncstatus` signal is driven high to indicate that synchronization is acquired. The `rx_syncstatus` signal is constantly driven high until the programmed number of erroneous code groups are received without receiving intermediate good groups; after which the `rx_syncstatus` signal is driven low. The word aligner indicates loss of synchronization (`rx_syncstatus` signal remains low) until the programmed number of valid synchronization code groups are received again.

In addition to restoring word boundaries, the word aligner supports the following features:

- Programmable run length violation detection—detects consecutive 1s or 0s in the data stream, and asserts run length violation signal (`rx_rlv`) when a preset run length threshold (maximum number of consecutive 1s or 0s) is detected. The `rx_rlv` signal in each channel is clocked by its parallel recovered clock and is asserted for a minimum of two recovered clock cycles to ensure that the FPGA fabric clock can latch the `rx_rlv` signal reliably because the FPGA fabric clock might have phase differences, ppm differences (in asynchronous systems), or both, with the recovered clock. Table 1-5 lists the run length violation circuit detection capabilities.

**Table 1-5. Run Length Violation Circuit Detection Capabilities**

Supported Data Width	Detector Range		Increment Step Settings
	Minimum	Maximum	
8-bit	4	128	4
10-bit	5	160	5

- Receiver polarity inversion—corrects accidental swapped positive and negative signals from the serial differential link during board layout. This feature works by inverting the polarity of every bit of the input data word to the word aligner, which has the same effect as swapping the positive and negative signals of the differential link. Inversion is dynamically controlled using `rx_invpolarity` port. [Figure 1-19](#) shows the receiver polarity inversion feature.

**Figure 1-19. Receiver Polarity Inversion**

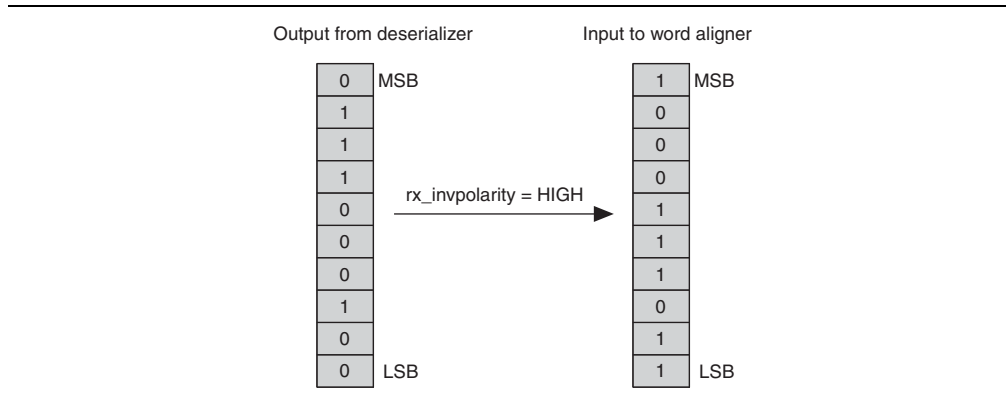

The generic receiver polarity inversion feature is different from the PCI Express (PIPE) 8B/10B polarity inversion feature. The generic receiver polarity inversion feature inverts the polarity of the data bits at the input of the word aligner and is not available in PCI Express (PIPE) mode. The PCI Express (PIPE) 8B/10B polarity inversion feature inverts the polarity of the data bits at the input of the 8B/10B decoder and is available only in PCI Express (PIPE) mode.

The `rx_invpolarity` signal is dynamic and might cause initial disparity errors in an 8B/10B encoded link. The downstream system must be able to tolerate these disparity errors.

- Receiver bit reversal—by default, the Cyclone IV GX receiver assumes LSB to MSB transmission. If the link transmission order is MSB to LSB, the receiver forwards the incorrect reverse bit-ordered version of the parallel data to the FPGA fabric on the `rx_dataout` port. The receiver bit reversal feature is available to correct this situation. This feature is static in manual alignment and automatic

synchronization state machine mode. In bit-slip mode, you can dynamically enable the receiver bit reversal using the `rx_revbitorderwa` port. When enabled, the 8-bit or 10-bit data `D[7..0]` or `D[9..0]` at the output of the word aligner is rewired to `D[0..7]` or `D[0..9]` respectively. Figure 1-20 shows the receiver bit reversal feature.

**Figure 1-20. Receiver Bit Reversal (1)**

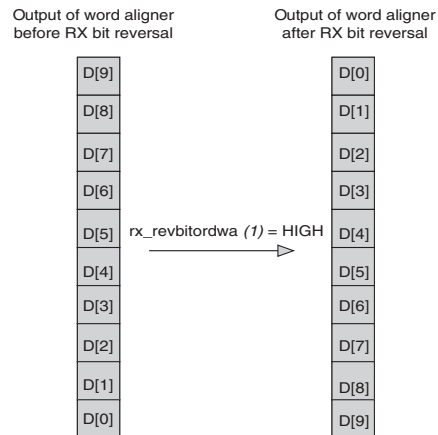

**Note to Figure 1-20:**

(1) The `rx_revbitorderwa` port is dynamic and is only available when the word aligner is configured in bit-slip mode.



When using the receiver bit reversal feature to receive MSB-to-LSB transmission, reversal of the word alignment pattern is required.

- Receiver bit-slip indicator—provides the number of bits slipped in the word aligner for synchronization with `rx_bitslipboundaryselectout` signal. For usage details, refer to “Receive Bit-Slip Indication” on page 1-76.

## Deskew FIFO

This module is only available when used for the XAUI protocol and is used to align all four channels to meet the maximum skew requirement of 40 UI (12.8 ns) as seen at the receiver of the four lanes. The deskew operation is compliant to the PCS deskew state machine diagram specified in clause 48 of the IEEE P802.3ae specification.

The deskew circuitry consists of a 16-word deep deskew FIFO in each of the four channels, and control logics in the central control unit of the transceiver block that controls the deskew FIFO write and read operations in each channel.

For details about the deskew FIFO operations for channel deskewing, refer to “XAUI Mode” on page 1-67.

## Rate Match FIFO

In asynchronous systems, the upstream transmitter and local receiver can be clocked with independent reference clocks. Frequency differences in the order of a few hundred ppm can corrupt the data when latching from the recovered clock domain (the same clock domain as the upstream transmitter reference clock) to the local receiver reference clock domain. Figure 1–21 shows the rate match FIFO block diagram.

**Figure 1–21. Rate Match FIFO Block Diagram**

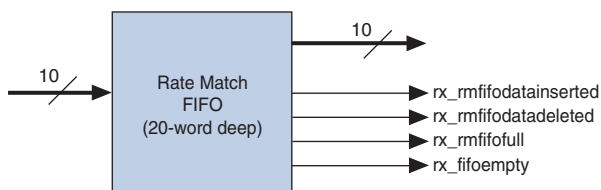

The rate match FIFO compensates for small clock frequency differences of up to  $\pm 300$  ppm (600 ppm total) between the upstream transmitter and the local receiver clocks by performing the following functions:

- Insert skip symbols when the local receiver reference clock frequency is greater than the upstream transmitter reference clock frequency
- Delete skip symbols when the local receiver reference clock frequency is less than the upstream transmitter reference clock frequency

The 20-word deep rate match FIFO and logics control insertion and deletion of skip symbols, depending on the ppm difference. The operation begins after the word aligner synchronization status (`rx_syncstatus`) is asserted.



Rate match FIFO is only supported with 8B/10B encoded data and the word aligner in automatic synchronization state machine mode.

## 8B/10B Decoder

The 8B/10B decoder receives 10-bit data and decodes it into an 8-bit data and a 1-bit control identifier. The decoder is compliant with Clause 36 of the IEEE 802.3 specification.

Figure 1–22 shows the 8B/10B decoder block diagram.

**Figure 1–22. 8B/10B Decoder Block Diagram**

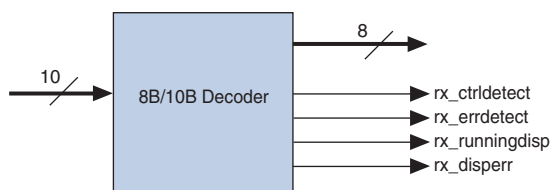

## Byte Deserializer

The byte deserializer halves the FPGA fabric-transceiver interface frequency while doubles the parallel data width to the FPGA fabric.

For example, when operating an EP4CGX150 receiver channel at 3.125 Gbps with deserialization factor of 10, the receiver PCS datapath runs at 312.5 MHz. The byte deserializer converts the 10-bit data at 312.5 MHz into 20-bit data at 156.25 MHz before forwarding the data to the FPGA fabric.

## Byte Ordering

In the 16- or 20-bit FPGA fabric-transceiver interface, the byte deserializer receives one data byte (8 or 10 bits) and deserializes it into two data bytes (16 or 20 bits). Depending on when the receiver PCS logic comes out of reset, the byte ordering at the output of the byte deserializer may not match the original byte ordering of the transmitted data. The byte misalignment resulting from byte deserialization is unpredictable because it depends on which byte is being received by the byte deserializer when it comes out of reset.

Figure 1-23 shows a scenario where the most significant byte and the least significant byte of the two-byte transmitter data appears straddled across two word boundaries after the data is deserialized at the receiver.

**Figure 1-23. Example of Byte Deserializer at the Receiver**

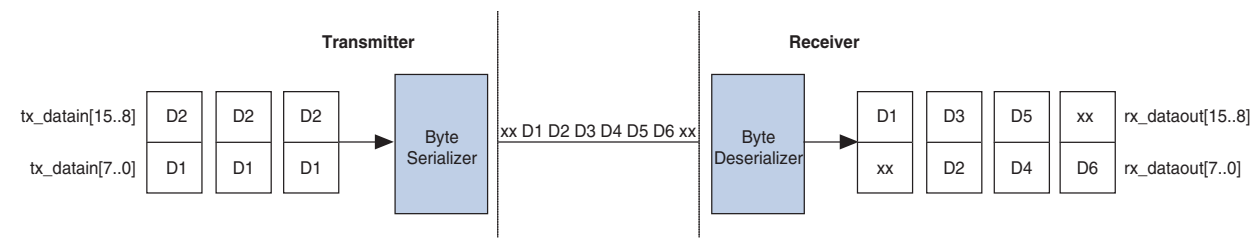

The byte ordering block restores the proper byte ordering by performing the following actions:

- Look for the user-programmed byte ordering pattern in the byte-deserialized data
- Inserts a user-programmed pad byte if the user-programmed byte ordering pattern is found in the most significant byte position

You must select a byte ordering pattern that you know appears at the least significant byte position of the parallel transmitter data.

The byte ordering block is supported in the following receiver configurations:

- 16-bit FPGA fabric-transceiver interface, 8B/10B disabled, and the word aligner in manual alignment mode. Program a custom 8-bit byte ordering pattern and 8-bit pad byte.
- 16-bit FPGA fabric-transceiver interface, 8B/10B enabled, and the word aligner in automatic synchronization state machine mode. Program a custom 9-bit byte ordering pattern and 9-bit pad byte. The MSB of the 9-bit byte ordering pattern and pad byte represents the control identifier of the 8B/10B decoded data.

The byte ordering block operates in either word-alignment-based byte ordering or user-controlled byte ordering modes.

In word-alignment-based byte ordering mode, the byte ordering block starts looking for the byte ordering pattern in the byte-deserialized data and restores the order if necessary when it detects a rising edge on the `rx_syncstatus` signal. Whenever the byte ordering pattern is found, the `rx_byteorderalignstatus` signal is asserted regardless if the pad byte insertion is necessary. If the byte ordering block detects another rising edge on the `rx_syncstatus` signal from the word aligner, it deasserts the `rx_byteorderalignstatus` signal and repeats the byte ordering operation.

In user-controlled byte ordering mode, the byte ordering operation is user-triggered using `rx_enabyteord` port. A rising edge on `rx_enabyteord` port triggers the byte ordering block to start looking for the byte ordering pattern in the byte-deserialized data and restores the order if necessary. When the byte ordering pattern is found, the `rx_byteorderalignstatus` signal is asserted regardless if a pad byte insertion is necessary.

## RX Phase Compensation FIFO

The RX phase compensation FIFO compensates for the phase difference between the parallel receiver clock and the FPGA fabric interface clock, when interfacing the receiver channel to the FPGA fabric (directly or through the PIPE and PCIe hard IP blocks). The FIFO is four words deep, with latency between two to three parallel clock cycles.

Figure 1–24 shows the RX phase compensation FIFO block diagram.

**Figure 1–24. RX Phase Compensation FIFO Block Diagram**

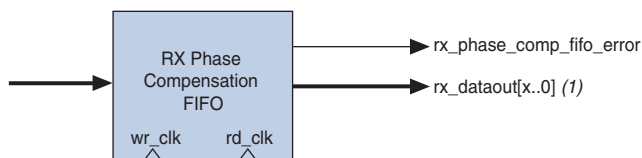

**Note to Figure 1–24:**

(1) Parameter x refers to the transceiver channel width, where 8, 10, 16, or 20 bits are supported.



The FIFO can operate in registered mode, contributing to only one parallel clock cycle of latency in the Deterministic Latency functional mode. For more information, refer to “[Deterministic Latency Mode](#)” on page 1–73. For more information about FIFO clocking, refer to “[FPGA Fabric-Transceiver Interface Clocking](#)” on page 1–43.

## Miscellaneous Receiver PCS Feature

The receiver PCS supports the following additional feature:

- **Output bit-flip**—reverses the bit order at a byte level at the output of the receiver phase compensation FIFO. For example, if the 16-bit parallel receiver data at the output of the receiver phase compensation FIFO is '10111100 10101101' (16'hBCAD), enabling this option reverses the data on `rx_dataout` port to '00111101 10110101' (16'h3DB5).

## Transceiver Clocking Architecture

The multipurpose PLLs and general-purpose PLLs located on the left side of the device generate the clocks required for the transceiver operation. The following sections describe the Cyclone IV GX transceiver clocking architecture:

- [“Input Reference Clocking” on page 1-27](#)
- [“Transceiver Channel Datapath Clocking” on page 1-29](#)
- [“FPGA Fabric-Transceiver Interface Clocking” on page 1-43](#)

## Input Reference Clocking

When used for transceiver, the left PLLs synthesize the input reference clock to generate the required clocks for the transceiver channels. [Figure 1-25](#) and [Figure 1-26](#) show the sources of input reference clocks for PLLs used in the transceiver operation.

 Clock output from PLLs in the FPGA core cannot feed into PLLs used by the transceiver as input reference clock.

**Figure 1-25. PLL Input Reference Clocks in Transceiver Operation for F324 and Smaller Packages** <sup>(1)</sup>, <sup>(2)</sup>

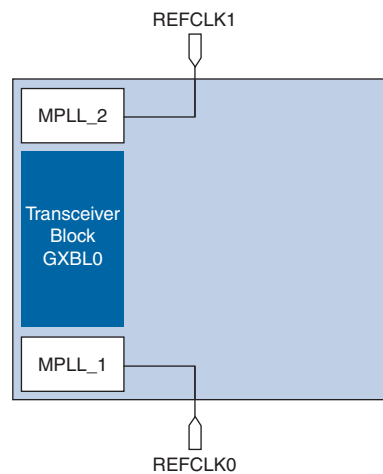

**Notes to [Figure 1-25](#):**

- (1) The REFCLK0 and REFCLK1 pins are dual-purpose CLK, REFCLK, or DIFFCLK pins that reside in banks 3A and 8A respectively.
- (2) Using any clock input pins other than the designated REFCLK pins as shown here to drive the MPLLs may have reduced jitter performance.

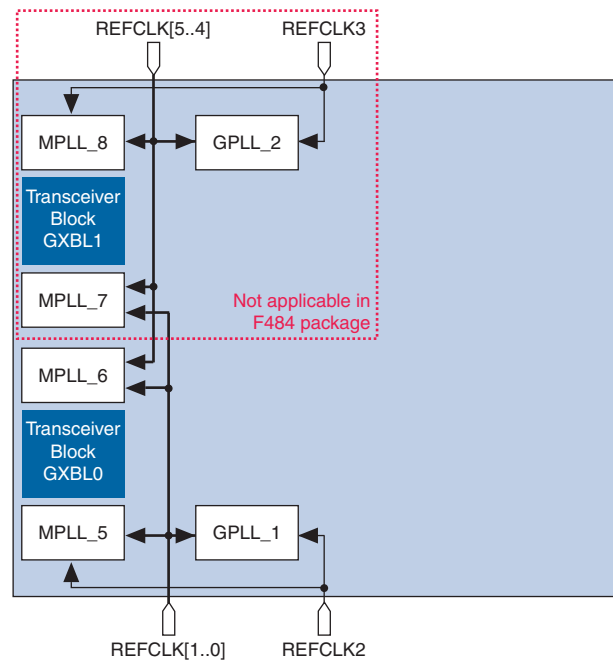
**Figure 1–26. PLL Input Reference Clocks in Transceiver Operation for F484 and Larger Packages**  
(1), (2), (3)**Notes to Figure 1–26:**

- (1) The REFCLK2 and REFCLK3 pins are dual-purpose CLKIO, REFCLK, or DIFFCLK pins that reside in banks 3A and 8A respectively.
- (2) The REFCLK[1..0] and REFCLK[5..4] pins are dual-purpose differential REFCLK or DIFFCLK pins that reside in banks 3B and 8B respectively. These clock input pins do not have access to the clock control blocks and GCLK networks. For more details, refer to the *Clock Networks and PLLs in Cyclone IV Devices* chapter.
- (3) Using any clock input pins other than the designated REFCLK pins as shown here to drive the MPLLs and GPLLs may have reduced jitter performance.

The input reference clocks reside in banks 3A, 3B, 8A, and 8B have dedicated  $V_{CC\_CLKIN3A}$ ,  $V_{CC\_CLKIN3B}$ ,  $V_{CC\_CLKIN8A}$ , and  $V_{CC\_CLKIN8B}$  power supplies separately in their respective I/O banks to avoid the different power level requirements in the same bank for general purpose I/Os (GPIOs). Table 1–6 lists the supported I/O standard for the REFCLK pins.

**Table 1–6. REFCLK I/O Standard Support**

I/O Standard	HSSI Protocol	Coupling	Termination	VCC_CLKIN Level		I/O Pin Type		
				Input	Output	Column I/O	Row I/O	Supported Banks
LVDS	ALL	Differential AC (Needs off-chip resistor to restore $V_{CM}$ )	Off-chip	2.5 V	Not Supported	Yes	No	3A, 3B, 8A, 8B
LVPECL	ALL			2.5 V	Not Supported	Yes	No	3A, 3B, 8A, 8B
1.2 V, 1.5 V, 3.3 V PCML	ALL			2.5 V	Not Supported	Yes	No	3A, 3B, 8A, 8B
	ALL			2.5 V	Not Supported	Yes	No	3A, 3B, 8A, 8B
	ALL			2.5 V	Not Supported	Yes	No	3A, 3B, 8A, 8B
HCSL	PCIe	Differential DC	Off-chip	2.5 V	Not Supported	Yes	No	3A, 3B, 8A, 8B

Figure 1-27 shows an example of the termination scheme for AC-coupled connections for REFCLK pins.

**Figure 1-27. AC-Coupled Termination Scheme for a Reference Clock**

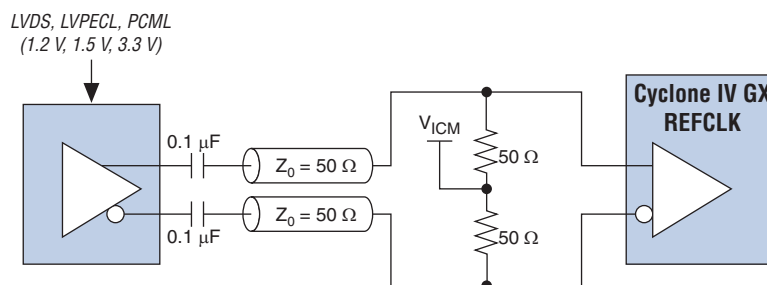

**Note to Figure 1-27:**

- (1) For more information about the  $V_{ICM}$  value, refer to the *Cyclone IV Device Datasheet* chapter.

Figure 1-28 shows an example termination scheme for the REFCLK pin when configured as a HCSL input.

**Figure 1-28. Termination Scheme for a Reference Clock When Configured as HCSL (1)**

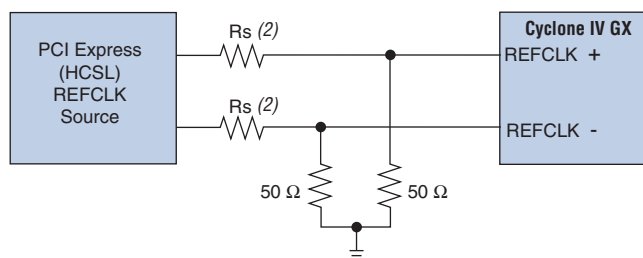

**Notes to Figure 1-28:**

- (1) No biasing is required if the reference clock signals are generated from a clock source that conforms to the PCIe specification.
- (2) Select values as recommended by the PCIe clock source vendor.

## Transceiver Channel Datapath Clocking

Channel datapath clocking varies with channel configuration options and PCS configurations. This section describes the clock distribution from the left PLLs for transceiver channels and the datapath clocking in various supported configurations.

Table 1-7 lists the clocks generated by the PLLs for transceiver datapath.

**Table 1-7. PLL Clocks for Transceiver Datapath**

Clock	Usage
CDR clocks	Receiver CDR unit
High-speed clock	Transmitter serializer block in PMA
Low-speed clock	Transmitter PCS blocks Receiver PCS blocks when rate match FIFO enabled

The CDR unit in each receiver channel gets the CDR clocks from one of the two multipurpose PLLs directly adjacent to the transceiver block. The CDR clocks distribution network is segmented by bidirectional tri-state buffers as shown in Figure 1-29 and Figure 1-30. This requires the CDR clocks from either one of the two multipurpose PLLs to drive a number of contiguous segmented paths to reach the intended receiver channel. Interleaving the CDR clocks from the two multipurpose PLLs is not supported.

For example, based on Figure 1-29, a combination of MPLL\_1 driving receiver channels 0, 1, and 3, while MPLL\_2 driving receiver channel 2 is not supported. In this case, only one multipurpose PLL can be used for the receiver channels.

**Figure 1-29. CDR Clocking for Transceiver Channels in F324 and Smaller Packages**

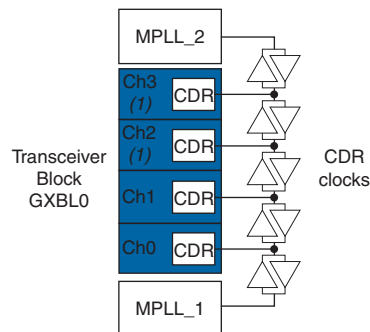

**Note to Figure 1-29:**

(1) Transceiver channels 2 and 3 are not available for devices in F169 and smaller packages.

**Figure 1-30. CDR Clocking for Transceiver Channels in F484 and Larger Packages**

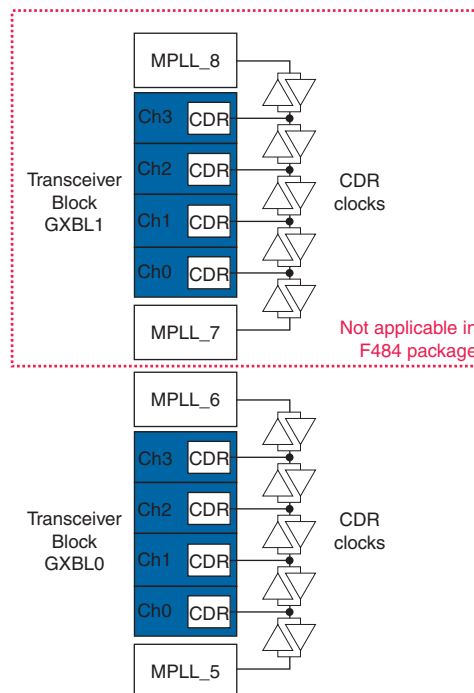

 In any configuration, a receiver channel cannot source CDR clocks from other PLLs beyond the two multipurpose PLLs directly adjacent to transceiver block where the channel resides.

The Cyclone IV GX transceivers support non-bonded (×1) and bonded (×2 and ×4) channel configurations. The two configurations differ in regards to clocking and phase compensation FIFO control. Bonded configuration provides a relatively lower channel-to-channel skew between the bonded channels than in non-bonded configuration. Table 1-8 lists the supported conditions in non-bonded and bonded channel configurations.

**Table 1-8. Supported Conditions in Non-Bonded and Bonded Channel Configurations**

Channel Configuration	Description	Supported Channel Operation Mode
Non-bonded (×1)	<ul style="list-style-type: none"> <li>■ Low-speed clock in each channel is sourced independently</li> <li>■ Phase compensation FIFO in each channel has its own pointers and control logic</li> </ul>	<ul style="list-style-type: none"> <li>■ Transmitter Only</li> <li>■ Receiver Only</li> <li>■ Transmitter and Receiver</li> </ul>
Bonded (×2 and ×4)	<ul style="list-style-type: none"> <li>■ Low-speed clock in each bonded channel is sourced from a common bonded clock path for lower channel-to-channel skew</li> <li>■ Phase compensation FIFOs in bonded channels share common pointers and control logic for equal latency through the FIFOs in all bonded channels</li> <li>■ ×2 bonded configuration is supported with channel 0 and channel 1 in a transceiver block</li> <li>■ ×4 bonded configuration is supported with all four channels in a transceiver block</li> </ul>	<ul style="list-style-type: none"> <li>■ Transmitter Only</li> <li>■ Transmitter and Receiver</li> </ul>

### Non-Bonded Channel Configuration

In non-bonded channel configuration, the high- and low-speed clocks for each channel are sourced independently. The phase compensation FIFOs in each channel has its own pointers and control logic. When implementing multi-channel serial interface in non-bonded channel configuration, the clock skew and unequal latency results in larger channel-to-channel skew.

 Altera recommends using bonded channel configuration (×2 or ×4) when implementing multi-channel serial interface for a lower channel-to-channel skew.

In a transceiver block, the high- and low-speed clocks for each channel are distributed primarily from one of the two multipurpose PLLs directly adjacent to the block. Transceiver channels for devices in F484 and larger packages support additional clocking flexibility. In these packages, some channels support high-speed and low-speed clock distribution from PLLs beyond the two multipurpose PLLs directly adjacent to the block.

Table 1-9 lists the high- and low-speed clock sources for each channel.

**Table 1-9. High- and Low-Speed Clock Sources for Each Channel in Non-Bonded Channel Configuration**

Package	Transceiver Block	Transceiver Channel	High- and Low-Speed Clocks Sources	
			Option 1	Option 2
F324 and smaller	GXBL0	All channels	MPLL_1	MPLL_2
F484 and larger	GXBL0	Channels 0, 1	MPLL_5/GPLL_1	MPLL_6
		Channels 2, 3	MPLL_5	MPLL_6/MPLL_7 <sup>(1)</sup>
	GXBL1 <sup>(1)</sup>	Channels 0, 1	MPLL_7/MPLL_6	MPLL_8
		Channels 2, 3	MPLL_7	MPLL_8/GPLL_2

**Note to Table 1-9:**

(1) MPLL\_7 and GXBL1 are not applicable for transceivers in F484 package

Figure 1-31 and Figure 1-32 show the high- and low-speed clock distribution for transceivers in F324 and smaller packages, and in F484 and larger packages in non-bonded channel configuration.

**Figure 1-31. Clock Distribution in Non-Bonded Channel Configuration for Transceivers in F324 and Smaller Packages**

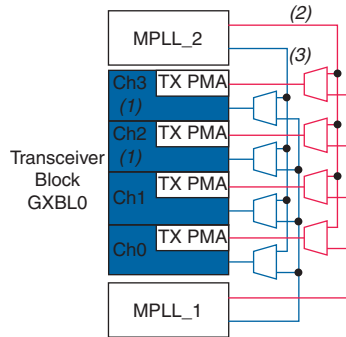

**Notes to Figure 1-31:**

- (1) Transceiver channels 2 and 3 are not available for devices in F169 and smaller packages.
- (2) High-speed clock.
- (3) Low-speed clock.

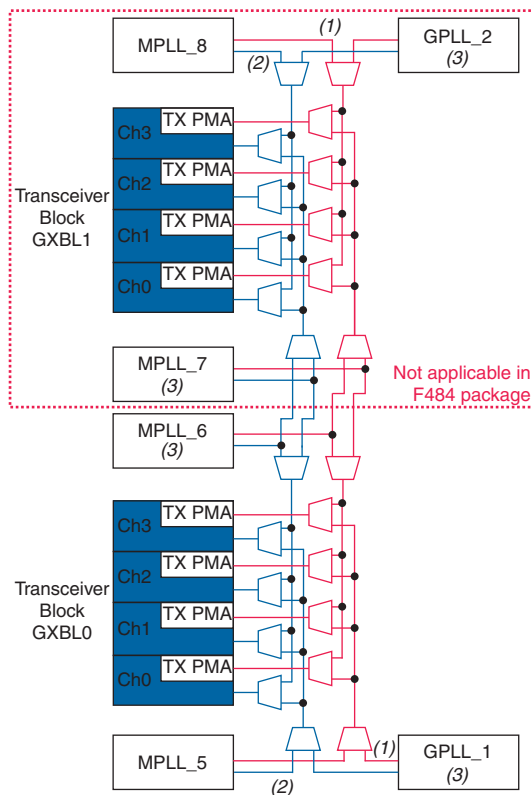
**Figure 1–32. Clock Distribution in Non-Bonded Channel Configuration for Transceivers in F484 and Larger Packages****Notes to Figure 1–32:**

- (1) High-speed clock.
- (2) Low-speed clock.
- (3) These PLLs have restricted clock driving capability and may not reach all connected channels. For details, refer to [Table 1–9](#).

The transceiver datapath clocking varies in non-bonded channel configuration depending on the PCS configuration.

[Figure 1–33](#) shows the datapath clocking in transmitter only operation. In this mode, each channel selects the high- and low-speed clock from one of the supported PLLs. The high-speed clock feeds to the serializer for parallel to serial operation. The low-speed clock feeds to the following blocks in the transmitter PCS:

- 8B/10B encoder
- read clock of the byte serializer
- read clock of the TX phase compensation FIFO

When the byte serializer is enabled, the low-speed clock frequency is halved before feeding into the read clock of TX phase compensation FIFO. The low-speed clock is available in the FPGA fabric as `tx_clkout` port, which can be used in the FPGA fabric to send transmitter data and control signals.

**Figure 1–33. Transmitter Only Datapath Clocking in Non-Bonded Channel Configuration**

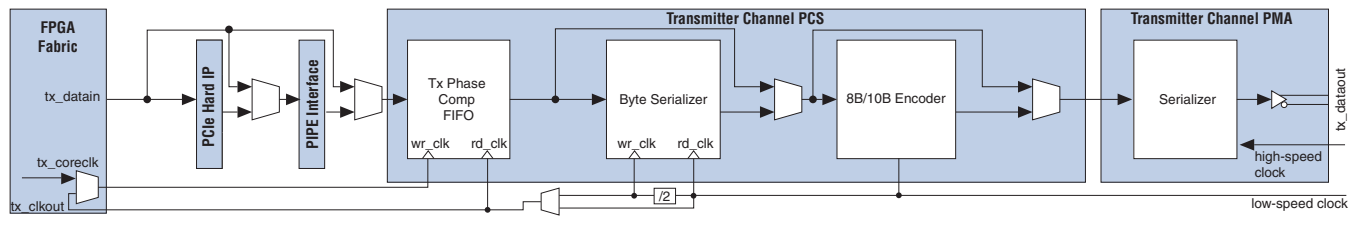
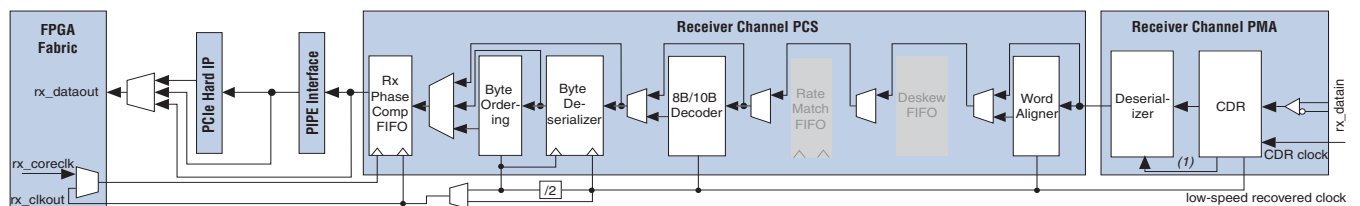

Figure 1–34 shows the datapath clocking in receiver only operation. In this mode, the receiver PCS supports configuration without the rate match FIFO. The CDR unit in the channel recovers the clock from the received serial data and generates the high-speed recovered clock for the deserializer, and low-speed recovered clock for forwarding to the receiver PCS. The low-speed recovered clock feeds to the following blocks in the receiver PCS:

- word aligner
- 8B/10B decoder
- write clock of byte deserializer
- byte ordering
- write clock of RX phase compensation FIFO

When the byte deserializer is enabled, the low-speed recovered clock frequency is halved before feeding into the write clock of the RX phase compensation FIFO. The low-speed recovered clock is available in the FPGA fabric as `rx_clkout` port, which can be used in the FPGA fabric to capture receiver data and status signals.

**Figure 1–34. Receiver Only Datapath Clocking without Rate Match FIFO in Non-Bonded Channel Configuration**



**Note to Figure 1–34:**

(1) High-speed recovered clock.

When the transceiver is configured for transmitter and receiver operation in non-bonded channel configuration, the receiver PCS supports configuration with and without the rate match FIFO. The difference is only at the receiver datapath clocking. The transmitter datapath clocking is identical to transmitter only operation mode as shown in Figure 1–33.

Figure 1-35 shows the datapath clocking in the transmitter and receiver operation mode with the rate match FIFO. The receiver datapath clocking in configuration without the rate match FIFO is identical to Figure 1-34.

In configuration with the rate match FIFO, the CDR unit in the receiver channel recovers the clock from received serial data and generates the high-speed recovered clock for the deserializer, and low-speed recovered clock for forwarding to the receiver PCS. The low-speed recovered clock feeds to the following blocks in the receiver PCS:

- word aligner
- write clock of rate match FIFO

The low-speed clock that is used in the transmitter PCS datapath feeds the following blocks in the receiver PCS:

- read clock of rate match FIFO
- 8B/10B decoder
- write clock of byte deserializer
- byte ordering
- write clock of RX phase compensation FIFO

When the byte deserializer is enabled, the low-speed clock frequency is halved before feeding into the write clock of RX phase compensation FIFO. The low-speed clock is available in the FPGA fabric as `tx_clkout` port, which can be used in the FPGA fabric to send transmitter data and control signals, and capture receiver data and status signals.

**Figure 1-35. Transmitter and Receiver Datapath Clocking with Rate Match FIFO in Non-Bonded Channel Configuration**

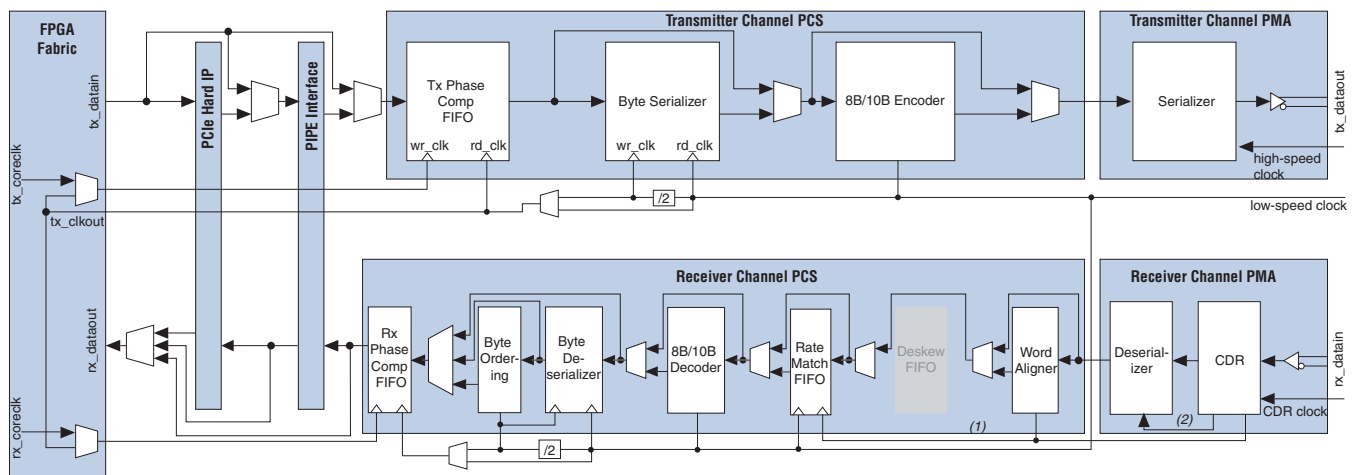

**Notes to Figure 1-35:**

- (1) Low-speed recovered clock.
- (2) High-speed recovered clock.

## Bonded Channel Configuration

In bonded channel configuration, the low-speed clock for the bonded channels share a common bonded clock path that reduces clock skew between the bonded channels. The phase compensation FIFOs in bonded channels share a set of pointers and control logic that results in equal FIFO latency between the bonded channels. These features collectively result in lower channel-to-channel skew when implementing multi-channel serial interface in bonded channel configuration.

In a transceiver block, the high-speed clock for each bonded channels is distributed independently from one of the two multipurpose PLLs directly adjacent to the block. The low-speed clock for bonded channels is distributed from a common bonded clock path that selects from one of the two multipurpose PLLs directly adjacent to the block. Transceiver channels for devices in F484 and larger packages support additional clocking flexibility for  $\times 2$  bonded channels. In these packages, the  $\times 2$  bonded channels support high-speed and low-speed bonded clock distribution from PLLs beyond the two multipurpose PLLs directly adjacent to the block. Table 1–10 lists the high- and low-speed clock sources for the bonded channels.

**Table 1–10. High- and Low-Speed Clock Sources for Bonded Channels in Bonded Channel Configuration**

Package	Transceiver Block	Bonded Channels	High- and Low-Speed Clocks Source	
			Option 1	Option 2
F324 and smaller	GXBLO	$\times 2$ in channels 0, 1 $\times 4$ in all channels	MPLL_1	MPLL_2
F484 and larger	GXBL0	$\times 2$ in channels 0, 1	MPLL_5/ GPLL_1	MPLL_6
		$\times 4$ in all channels	MPLL_5	MPLL_6
	GXBL1 (1)	$\times 2$ in channels 0, 1	MPLL_7/ MPLL_6	MPLL_8
		$\times 4$ in all channels	MPLL_7	MPLL_8

**Note to Table 1–10:**

(1) GXBL1 is not available for transceivers in F484 package.



When implementing  $\times 2$  bonded channel configuration in a transceiver block, remaining channels 2 and 3 are available to implement other non-bonded channel configuration.

Figure 1-36 and Figure 1-37 show the independent high-speed clock and bonded low-speed clock distributions for transceivers in F324 and smaller packages, and in F484 and larger packages in bonded ( $\times 2$  and  $\times 4$ ) channel configuration.

**Figure 1-36. Clock Distribution in Bonded ( $\times 2$  and  $\times 4$ ) Channel Configuration for Transceivers in F324 and Smaller Packages.**

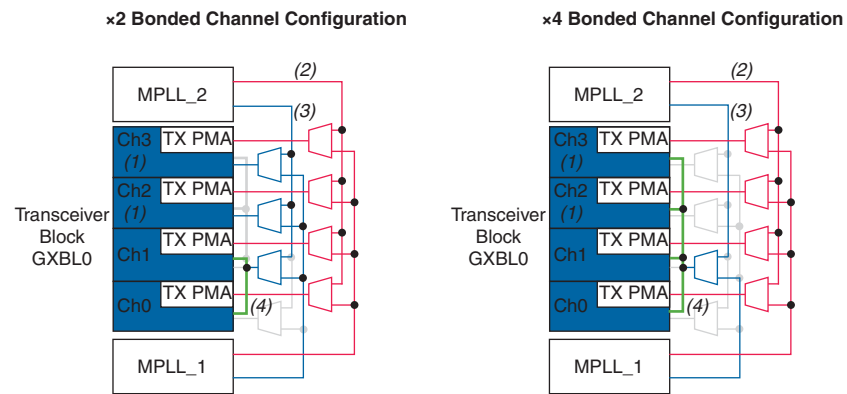

**Notes to Figure 1-36:**

- (1) Transceiver channels 2 and 3 are not available for devices in F169 and smaller packages.
- (2) High-speed clock.
- (3) Low-speed clock.
- (4) Bonded common low-speed clock path.

**Figure 1-37. Clock Distribution in Bonded ( $\times 2$  and  $\times 4$ ) Channel Configuration for Transceivers in F484 and Larger Packages**

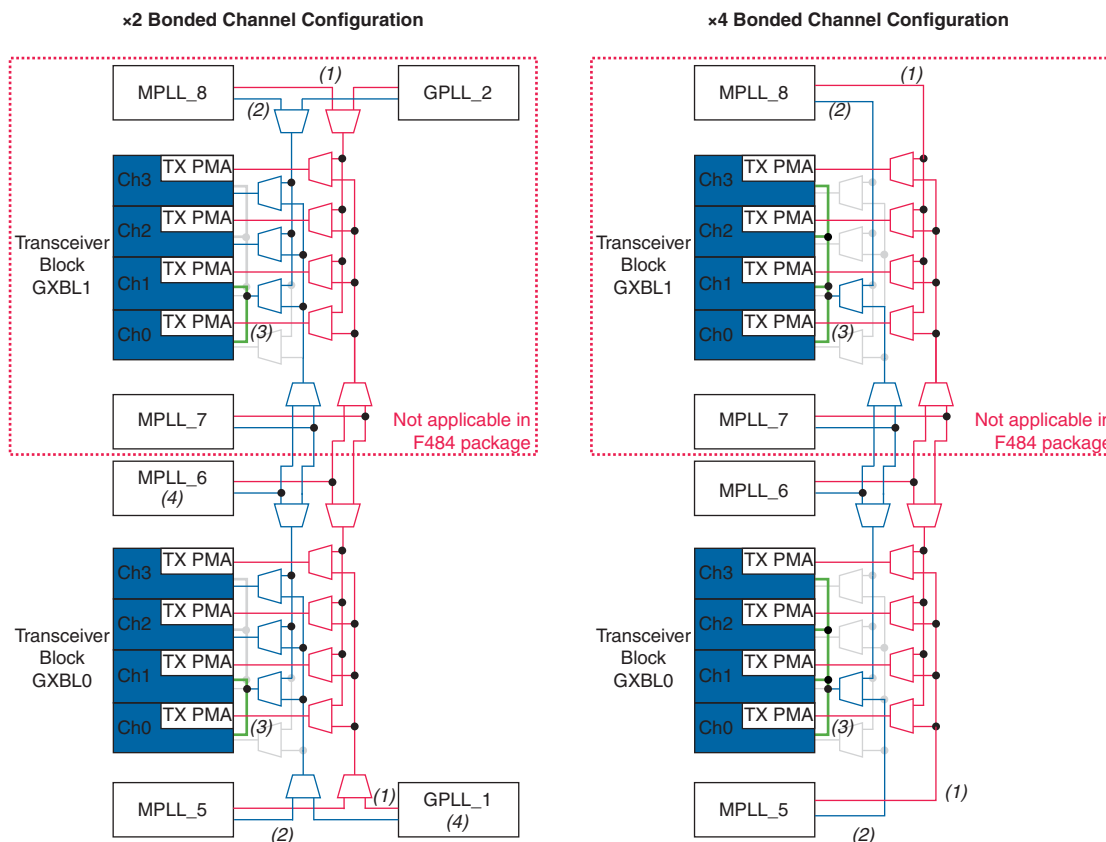

**Notes to Figure 1-37:**

- (1) High-speed clock.
- (2) Low-speed clock.
- (3) Bonded common low-speed clock path.
- (4) These PLLs have restricted clock driving capability and may not reach all connected channels. For details, refer to [Table 1-10](#).

The channel datapath clocking is similar between bonded channels in  $\times 2$  and  $\times 4$  configurations.

[Figure 1-38](#) shows the datapath clocking in Transmitter Only operation for  $\times 2$  and  $\times 4$  bonded configurations. In these configurations, each bonded channel selects the high-speed clock from one of the supported PLLs. The high-speed clock in each bonded channel feeds the respective serializer for parallel to serial operation. The common bonded low-speed clock feeds to each bonded channel that is used for the following blocks in each transmitter PCS channel:

- 8B/10B encoder
- read clock of byte serializer
- read clock of TX phase compensation FIFO

When the byte serializer is enabled, the common bonded low-speed clock frequency is halved before feeding to the read clock of TX phase compensation FIFO. The common bonded low-speed clock is available in FPGA fabric as `coreclkout` port, which can be used in FPGA fabric to send transmitter data and control signals to the bonded channels.

**Figure 1–38. Transmitter Only Datapath Clocking in Bonded Channel Configuration**

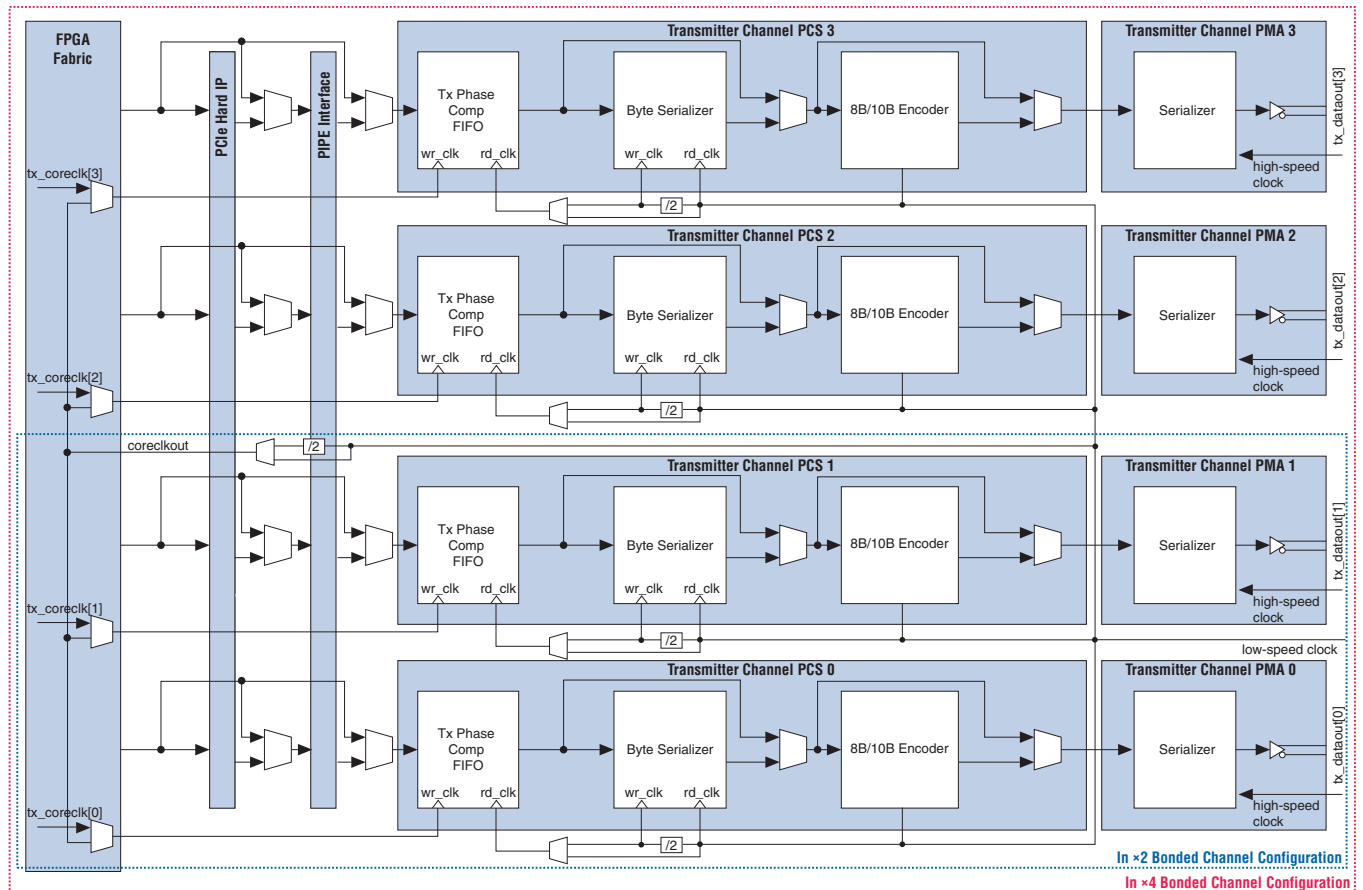

 Bonded channel configuration is not available for Receiver Only channel operation because each of the channels are individually clocked by its recovered clock.

For Transmitter and Receiver operation in bonded channel configuration, the receiver PCS supports configuration with rate match FIFO, and configuration without rate match FIFO. [Figure 1-39](#) shows the datapath clocking in Transmitter and Receiver operation with rate match FIFO in  $\times 2$  and  $\times 4$  bonded channel configurations. For Transmitter and Receiver operation in bonded channel configuration without rate match FIFO, the datapath clocking is identical to [Figure 1-38](#) for the bonded transmitter channels, and [Figure 1-34 on page 1-35](#) for the receiver channels.

Figure 1-39. Transmitter and Receiver Datapath Clocking with Rate Match FIFO in Bonded Channel Configuration

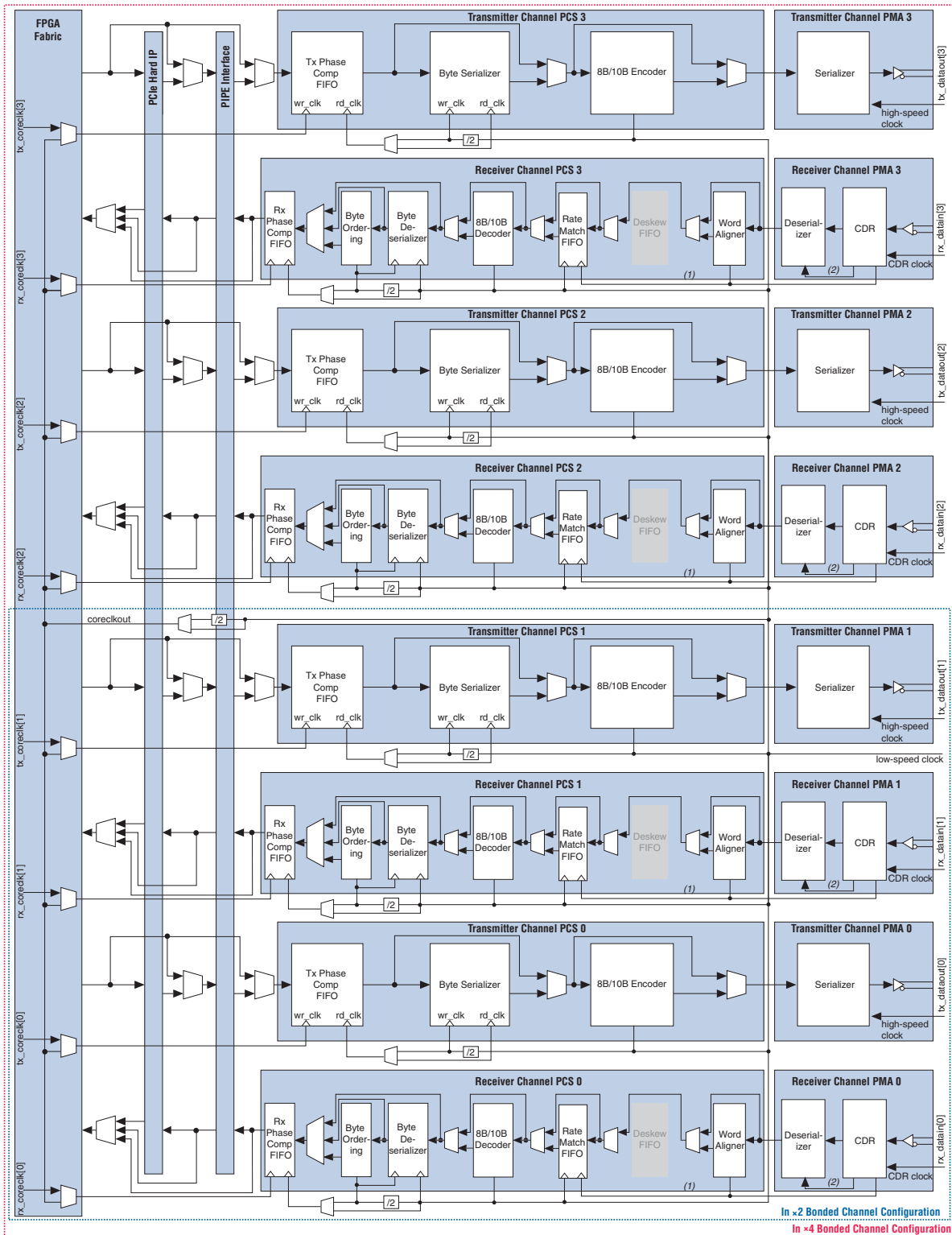

Notes to Figure 1-39:

- (1) Low-speed recovered clock.
- (2) High-speed recovered clock.

In configuration with rate match FIFO, the transmitter datapath clocking is identical to Transmitter Only operation as shown in [Figure 1-38](#). In each bonded receiver channel, the CDR unit recovers the clock from serial received data and generates the high- and low-speed recovered clock for each bonded channel. The high-speed recovered clock feeds the channel's deserializer, and low-speed recovered clock is forwarded to receiver PCS. The individual low-speed recovered clock feeds to the following blocks in the receiver PCS:

- word aligner
- write clock of rate match FIFO

The common bonded low-speed clock that is used in all bonded transmitter PCS datapaths feeds the following blocks in each bonded receiver PCS:

- read clock of rate match FIFO
- 8B/10B decoder
- write clock of byte deserializer
- byte ordering
- write clock of RX phase compensation FIFO

When the byte deserializer is enabled, the common bonded low-speed clock frequency is halved before feeding to the write clock of RX phase compensation FIFO. The common bonded low-speed clock is available in FPGA fabric as `coreclkout` port, which can be used in FPGA fabric to send transmitter data and control signals, and capture receiver data and status signals from the bonded channels.

## FPGA Fabric-Transceiver Interface Clocking

The FPGA fabric-transceiver interface clocks consists of clock signals from the FPGA fabric to the transceiver blocks, and from the transceiver blocks to the FPGA fabric. These clock resources use the global clock networks (GCLK) in the FPGA core.



For information about the GCLK resources in the Cyclone IV GX devices, refer to [Clock Networks and PLLs in Cyclone IV Devices](#) chapter.

[Table 1-11](#) lists the FPGA fabric-transceiver interface clocks.

**Table 1-11. FPGA Fabric-Transceiver Interface Clocks (Part 1 of 2)**

Clock Name	Clock Description	Interface Direction
tx_clkout	Phase compensation FIFO clock	Transceiver to FPGA fabric
rx_clkout	Phase compensation FIFO clock	Transceiver to FPGA fabric
coreclkout	Phase compensation FIFO clock	Transceiver to FPGA fabric
fixed_clk	125MHz receiver detect clock in PIPE mode	FPGA fabric to transceiver
reconfig_clk <sup>(1), (2)</sup>	Transceiver dynamic reconfiguration and offset cancellation clock	FPGA fabric to transceiver

**Table 1-11. FPGA Fabric-Transceiver Interface Clocks (Part 2 of 2)**

Clock Name	Clock Description	Interface Direction
cal_blk_clk <sup>(2)</sup>	Transceiver calibration block clock	FPGA fabric to transceiver

**Notes to Table 1-11:**

- (1) Offset cancellation process that is executed after power cycle requires `reconfig_clk` clock. The `reconfig_clk` must be driven with a free-running clock and not derived from the transceiver blocks.
- (2) For the supported clock frequency range, refer to the *Cyclone IV Device Data Sheet*.

In the transmitter datapath, TX phase compensation FIFO forms the FPGA fabric-transmitter interface. Data and control signals for the transmitter are clocked with the FIFO write clock. The FIFO write clock supports automatic clock selection by the Quartus II software (depending on channel configuration), or user-specified clock from `tx_coreclk` port. Table 1-12 details the automatic TX phase compensation FIFO write clock selection by the Quartus II software.



The Quartus II software assumes automatic clock selection for TX phase compensation FIFO write clock if you do not enable the `tx_coreclk` port.

**Table 1-12. Automatic TX Phase Compensation FIFO Write Clock Selection**

Channel Configuration	Quartus II Selection
Non-bonded	<code>tx_clkout</code> clock feeds the FIFO write clock. <code>tx_clkout</code> is forwarded through the transmitter channel from low-speed clock, which also feeds the FIFO read clock.
Bonded	<code>coreclkout</code> clock feeds the FIFO write clock for the bonded channels. <code>coreclkout</code> clock is the common bonded low-speed clock, which also feeds the FIFO read clock in the bonded channels.

When using user-specified clock option, ensure that the clock feeding `tx_coreclk` port has 0 ppm difference with the TX phase compensation FIFO read clock.

In the receiver datapath, RX phase compensation FIFO forms the receiver-FPGA fabric interface. Data and status signals from the receiver are clocked with the FIFO read clock. The FIFO read clock supports automatic clock selection by the Quartus II software (depending on channel configuration), or user-specified clock from `rx_coreclk` port. Table 1-13 details the automatic RX phase compensation FIFO read clock selection by the Quartus II software.



The Quartus II software assumes automatic clock selection for RX phase compensation FIFO read clock if you do not enable the `rx_coreclk` port.

**Table 1-13. Automatic RX Phase Compensation FIFO Read Clock Selection (Part 1 of 2)**

Channel Configuration	Quartus II Selection	
Non-bonded	With rate match FIFO <sup>(1)</sup>	<code>tx_clkout</code> clock feeds the FIFO read clock. <code>tx_clkout</code> is forwarded through the receiver channel from low-speed clock, which also feeds the FIFO write clock and transmitter PCS.
	Without rate match FIFO	<code>rx_clkout</code> clock feeds the FIFO read clock. <code>rx_clkout</code> is forwarded through the receiver channel from low-speed recovered clock, which also feeds the FIFO write clock.

**Table 1-13. Automatic RX Phase Compensation FIFO Read Clock Selection (Part 2 of 2)**

Channel Configuration		Quartus II Selection
Bonded	With rate match FIFO <sup>(1)</sup>	coreclkout clock feeds the FIFO read clock for the bonded channels. coreclkout clock is the common bonded low-speed clock, which also feeds the FIFO read clock and transmitter PCS in the bonded channels.
	Without rate match FIFO	rx_clkout clock feeds the FIFO read clock. rx_clkout is forwarded through the receiver channel from low-speed recovered clock, which also feeds the FIFO write clock.

**Note to Table 1-13:**

(1) Configuration with rate match FIFO is supported in transmitter and receiver operation.

When using user-specified clock option, ensure that the clock feeding rx\_coreclk port has 0 ppm difference with the RX phase compensation FIFO write clock.

## Calibration Block

This block calibrates the OCT resistors and the analog portions of the transceiver blocks to ensure that the functionality is independent of process, voltage, and temperature (PVT) variations.

Figure 1-40 shows the location of the calibration block and how it is connected to the transceiver blocks.

**Figure 1-40. Transceiver Calibration Blocks Location and Connection**

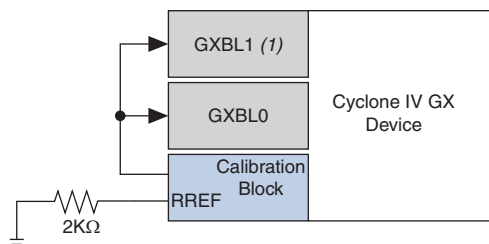

**Note to Figure 1-40:**

(1) Transceiver block GXBL1 is only available for devices in F484 and larger packages.

The calibration block internally generates a constant internal reference voltage, independent of PVT variations and uses this voltage and the external reference resistor on the RREF pin to generate constant reference currents. The OCT calibration circuit calibrates the OCT resistors present in the transceiver channels. Figure 1-41 shows the calibration block diagram.

**Figure 1-41. Input Signals to the Calibration Blocks (1)**

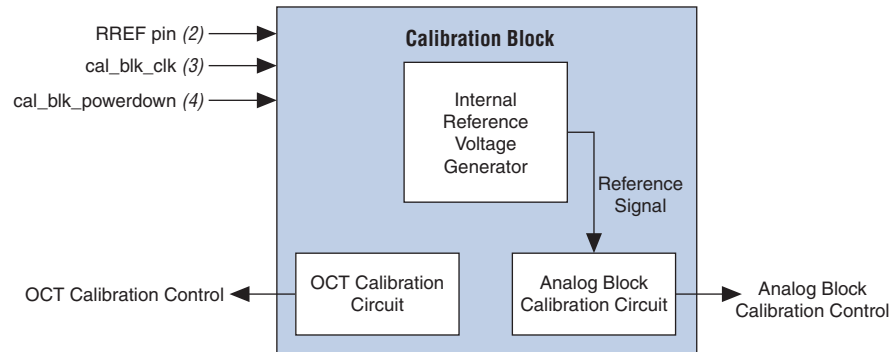

**Notes to Figure 1-41:**

- (1) All transceiver channels use the same calibration block clock and power down signals.
- (2) Connect a 2 k $\Omega$  (tolerance max  $\pm$  1%) external resistor to the RREF pin to ground. The RREF resistor connection in the board must be free from any external noise.
- (3) Supports up to 125 MHz clock frequency. Use either dedicated global clock or divide-down logic from the FPGA fabric to generate a slow clock on the local clock routing.
- (4) The calibration block restarts the calibration process following deassertion of the cal\_blk\_powerdown signal.

## PCI-Express Hard IP Block

Figure 1-42 shows the block diagram of the PCIe hard IP block implementing the PHY MAC, Data Link Layer, and Transaction Layer for PCIe interfaces. The PIPE interface is used as the interface between the transceiver and the hard IP block.

**Figure 1-42. PCI Express Hard IP High-Level Block Diagram**

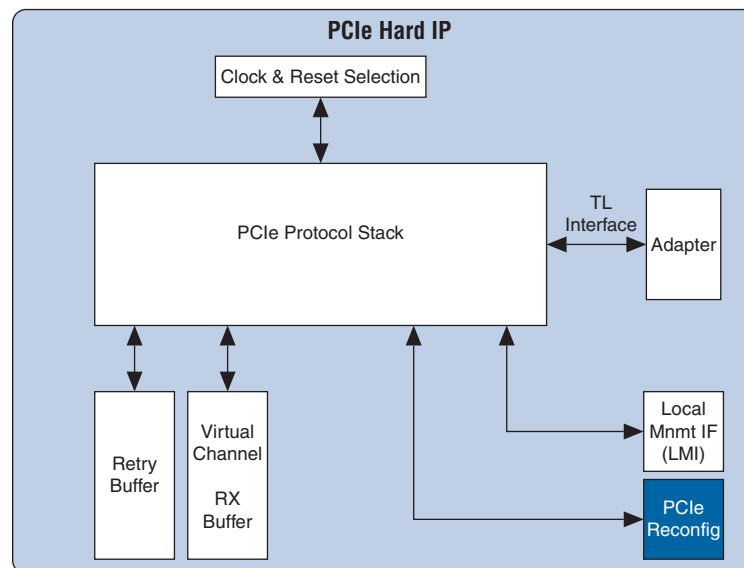

The hard IP block supports 1, 2, or 4 initial lane configurations with a maximum payload of 256 bytes at Gen1 frequency. The application interface is 64 bits with a data width of 16 bits per channel running at up to 125 MHz. As a hard macro and a verified block, it uses very few FPGA resources, while significantly reducing design risk and the time required to achieve timing closure. It is compliant with the PCI Express Base Specification 1.1. You do not have to pay a licensing fee to use this module. Configuring the hard IP block requires using the PCI Express Compiler.

For more information about the hard IP block, refer to the *PCI Express Compiler User Guide*.

Figure 1-43 shows the lane placement requirements when implementing PCIe with hard IP block.

**Figure 1-43. PCIe with Hard IP Block Lane Placement Requirements <sup>(1)</sup>**

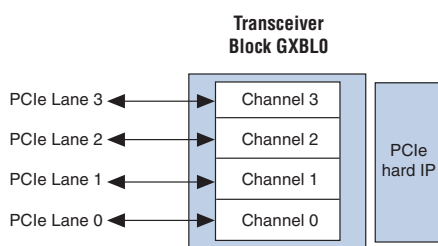

**Note to Figure 1-43:**

(1) Applicable for PCIe x1, x2, and x4 implementations with hard IP blocks only.

## Transceiver Functional Modes

The Cyclone IV GX transceiver supports the functional modes as listed in Table 1-14 for protocol implementation.

**Table 1-14. Transceiver Functional Modes for Protocol Implementation (Part 1 of 2)**

Functional Mode	Protocol	Key Feature	Reference
Basic	Proprietary, SATA, V-by-One, Display Port	Low latency PCS, transmitter in electrical idle, signal detect at receiver, wider spread asynchronous SSC	“Basic Mode” on page 1-48
PCI Express (PIPE)	PCIe Gen1 with PIPE Interface	PIPE ports, receiver detect, transmitter in electrical idle, electrical idle inference, signal detect at receiver, fast recovery, protocol-compliant word aligner and rate match FIFO, synchronous SSC	“PCI Express (PIPE) Mode” on page 1-52
GIGE	GbE	Running disparity preservation, protocol-compliant word aligner, recovered clock port for applications such as Synchronous Ethernet	“GIGE Mode” on page 1-59
Serial RapidIO	SRIO	Protocol-compliant word aligner	“Serial RapidIO Mode” on page 1-64
XAUI	XAUI	Deskew FIFO, protocol-compliant word aligner and rate match FIFO	“XAUI Mode” on page 1-67

**Table 1-14. Transceiver Functional Modes for Protocol Implementation (Part 2 of 2)**

Functional Mode	Protocol	Key Feature	Reference
Deterministic Latency	Proprietary, CPRI, OBSAI	TX PLL phase frequency detector (PFD) feedback, registered mode FIFO, TX bit-slip control	“Deterministic Latency Mode” on page 1-73
SDI	SDI	High-speed SERDES, CDR	“SDI Mode” on page 1-76

## Basic Mode

The Cyclone IV GX transceiver channel datapath is highly flexible in Basic mode to implement proprietary protocols. SATA, V-by-One, and Display Port protocol implementations in Cyclone IV GX transceiver are supported with Basic mode.

Figure 1-44 shows the transceiver channel datapath supported in Basic mode.

**Figure 1-44. Transceiver Channel Datapath in Basic Mode**

Figure 1-45 and Figure 1-46 show the supported transceiver configurations in Basic mode with the 8-bit and 10-bit PMA-PCS interface width respectively.

**Figure 1-45. Supported Transceiver Configurations in Basic Mode with the 8-bit PMA-PCS Interface Width**



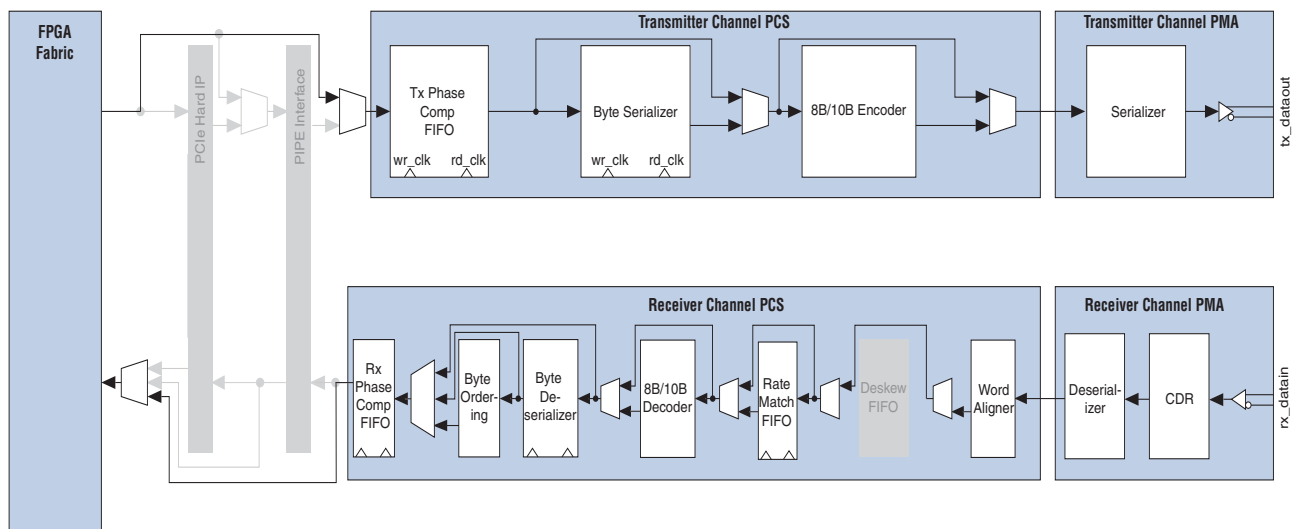
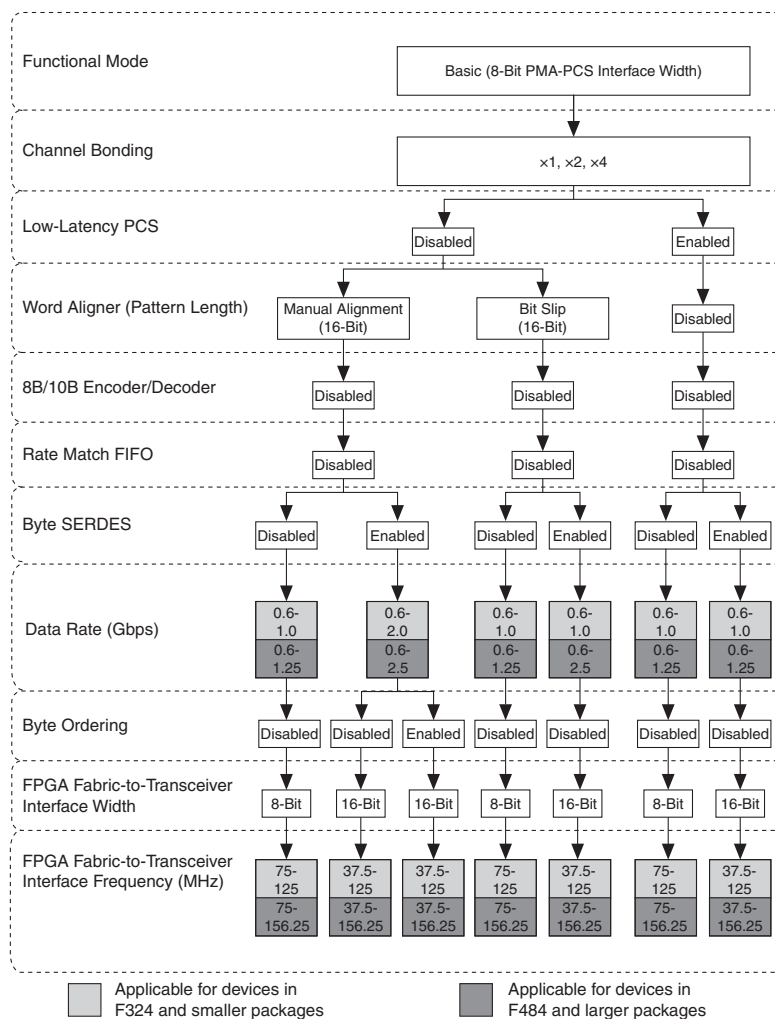

- transmitter in electrical idle
- receiver signal detect
- receiver spread spectrum clocking

### Low-Latency PCS Operation

When configured in low-latency PCS operation, the following blocks in the transceiver PCS are bypassed, resulting in a lower latency PCS datapath:

- 8B/10B encoder and decoder
- word aligner
- rate match FIFO
- byte ordering

Figure 1-47 shows the transceiver channel datapath in Basic mode with low-latency PCS operation.

**Figure 1-47. Transceiver Channel Datapath in Basic Mode with Low-Latency PCS Operation**

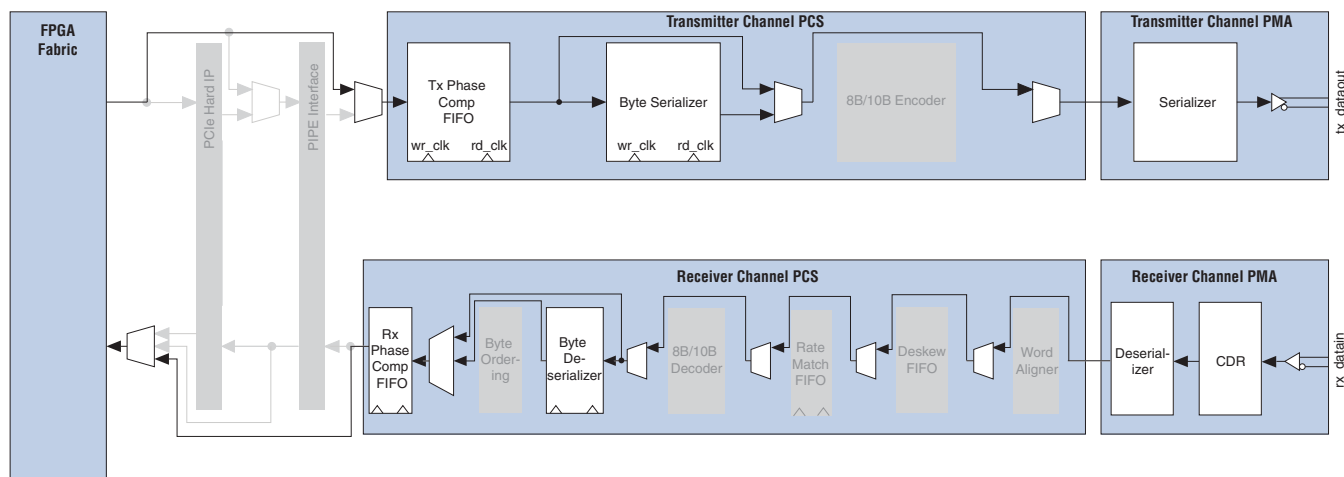

### Transmitter in Electrical Idle

The transmitter buffer supports electrical idle state, where when enabled, the differential output buffer driver is tri-stated. During electrical idle, the output buffer assumes the common mode output voltage levels. For details about the electrical idle features, refer to “PCI Express (PIPE) Mode” on page 1-52.



The transmitter in electrical idle feature is required for compliance to the version 2.00 of PHY Interface for the PCI Express (PIPE) Architecture specification for PCIe protocol implementation.

### Signal Detect at Receiver

Signal detect at receiver is only supported when 8B/10B encoder/decoder block is enabled.

## Receiver Spread Spectrum Clocking

Asynchronous SSC is not supported in Cyclone IV devices. You can implement only synchronous SSC for SATA, V-by-One, and Display Port protocols in Basic mode.

## PCI Express (PIPE) Mode

PIPE mode provides the transceiver channel datapath configuration that supports  $\times 1$ ,  $\times 2$ , and  $\times 4$  initial lane width for PCIe Gen1 signaling rate with PIPE interface implementation. The Cyclone IV GX transceiver provides following features in PIPE mode:

- PIPE interface
- receiver detection circuitry
- electrical idle control
- signal detect at receiver
- lane synchronization with compliant state machine
- clock rate compensation with rate match FIFO
- Low-Latency Synchronous PCIe
- fast recovery from P0s state
- electrical idle inference
- compliance pattern transmission
- reset requirement

Figure 1-48 shows the transceiver channel datapath and clocking when configured in PIPE mode with  $\times 1$  channel configuration.

**Figure 1-48. Transceiver Channel Datapath and Clocking when Configured in PIPE Mode with  $\times 1$  Channel Configuration**

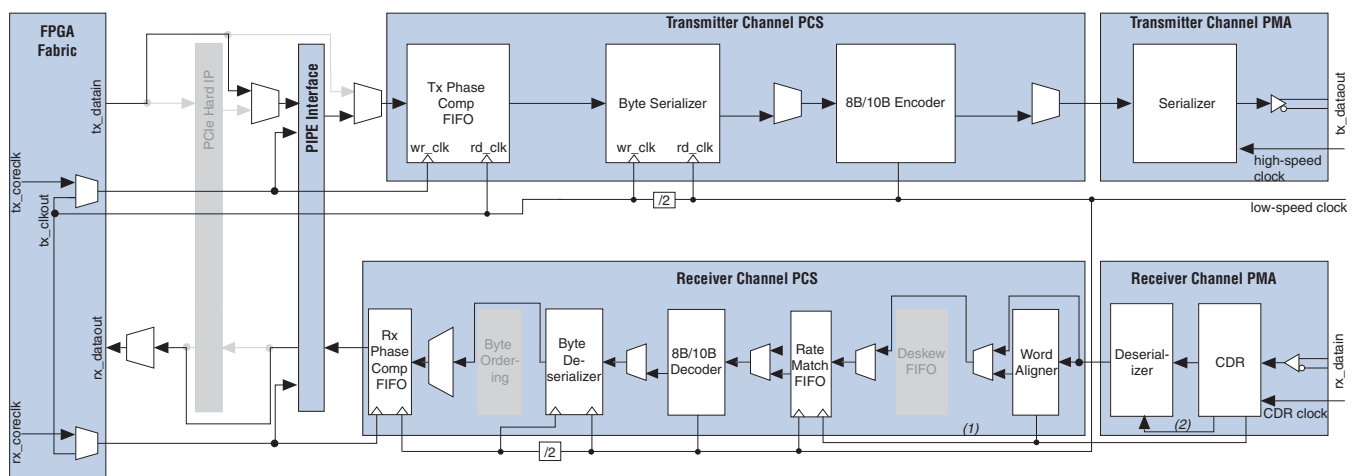

### Notes to Figure 1-48:

- (1) Low-speed recovered clock.
- (2) High-speed recovered clock.

Configuring the hard IP module requires using the PCI Express Compiler. When configuring the transceiver for PCIe implementation with hard IP module, the byte serializer and deserializer are not enabled, providing an 8-bit transceiver-PIPE-hard IP data interface width running at 250 MHz clock frequency.



 For more information about PCIe implementation with hard IP module, refer to the *PCI Express Compiler User Guide*.

Figure 1-49 shows the transceiver configuration in PIPE mode.

**Figure 1-49. Transceiver Configuration in PIPE Mode**

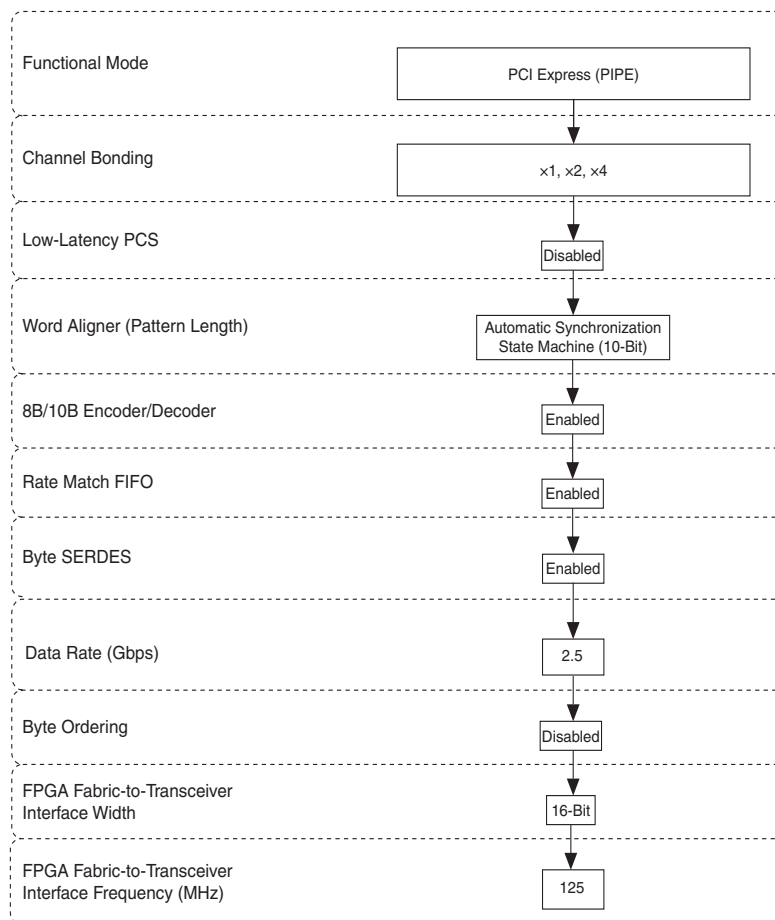

 When configuring the transceiver into PIPE mode using ALTGX megafunction for PCIe implementation, the PHY-MAC, data link and transaction layers must be implemented in user logics. The PCIe hard IP block is bypassed in this configuration.

## PIPE Interface

The PIPE interface provides a standard interface between the PCIe-compliant PHY and MAC layer as defined by the version 2.00 of the PIPE Architecture specification for Gen1 (2.5 Gbps) signaling rate. Any core or IP implementing the PHY MAC, data link, and transaction layers that supports PIPE 2.00 can be connected to the Cyclone IV GX transceiver configured in PIPE mode. Table 1–15 lists the PIPE-specific ports available from the Cyclone IV GX transceiver configured in PIPE mode and the corresponding port names in the PIPE 2.00 specification.

**Table 1–15. Transceiver-FPGA Fabric Interface Ports in PIPE Mode**

Transceiver Port Name	PIPE 2.00 Port Name
tx_datain[15..0] <sup>(1)</sup>	TxData[15..0]
tx_ctrlenable[1..0] <sup>(1)</sup>	TxDataK[1..0]
rx_dataout[15..0] <sup>(1)</sup>	RxData[15..0]
rx_ctrldetect[1..0] <sup>(1)</sup>	RxDataK[1..0]
tx_detectrxloop	TxDetectRx/Loopback
tx_forceelecidle	TxElecIdle
tx_forcedispcompliance	TxCompliance
pipe8b10binvpolarity	RxPolarity
powerdn[1..0] <sup>(2)</sup>	PowerDown[1..0]
pipedatavalid	RxValid
pipephydonestatus	PhyStatus
pipeelecidle	RxElecIdle
pipestatus	RxStatus[2..0]

**Notes to Table 1–15:**

- (1) When used with PCIe hard IP block, the byte SERDES is not used. In this case, the data ports are 8 bits wide and control identifier is 1 bit wide.
- (2) Cyclone IV GX transceivers do not implement power saving measures in lower power states (P0s, P1, and P2), except when putting the transmitter buffer in electrical idle in the lower power states.

## Receiver Detection Circuitry

In PIPE mode, the transmitter supports receiver detection function with a built-in circuitry in the transmitter PMA. The PCIe protocol requires the transmitter to detect if a receiver is present at the far end of each lane as part of the link training and synchronization state machine sequence. This feature requires the following conditions:

- transmitter output buffer to be tri-stated
- have OCT utilization
- 125 MHz clock on the fixedclk port

The circuit works by sending a pulse on the common mode of the transmitter. If an active PCIe receiver is present at the far end, the time constant of the step voltage on the trace is higher compared to when the receiver is not present. The circuitry monitors the time constant of the step signal seen on the trace to decide if a receiver was detected.

Figure 1-50 and Figure 1-51 show the detection mechanism example for a successful and unsuccessful receiver detection scenarios respectively. The tx\_forceidle port must be asserted at least 10 parallel clock cycles prior to assertion of tx\_detectrxloopback port to ensure the transmitter buffer is properly tri-stated. Detection completion is indicated by pipephydonestatus assertion, with detection successful indicated by 3'b011 on pipestatus[2..0] port, or detection unsuccessful by 3'b000 on pipestatus[2..0] port.

**Figure 1-50. Example of Successful Receiver Detect Operation**

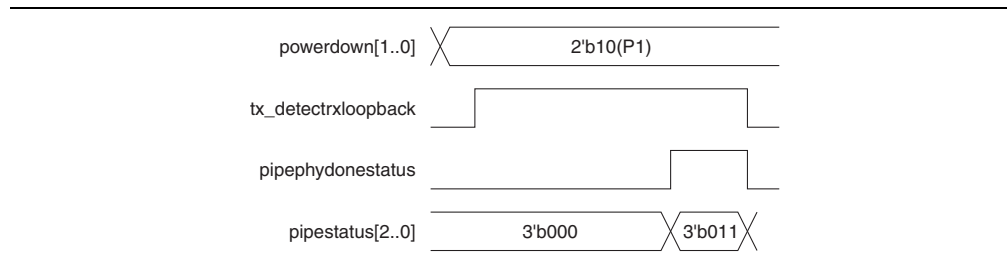

**Figure 1-51. Example of Unsuccessful Receiver Detect Operation**

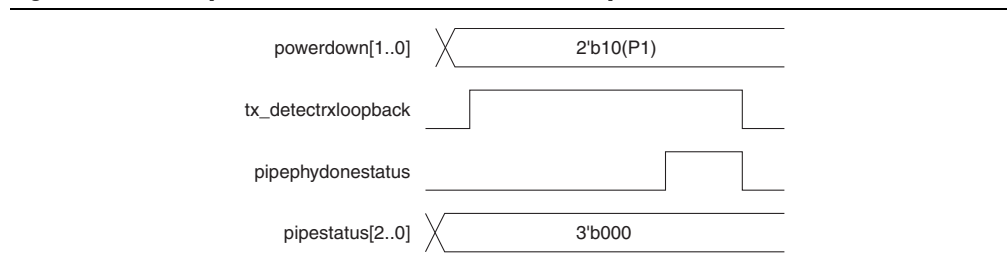

## Electrical Idle Control

The Cyclone IV GX transceivers support transmitter buffer in electrical idle state using the tx\_forceidle port. During electrical idle, the transmitter buffer differential and common mode output voltage levels are compliant to the PCIe Base Specification 2.0 for Gen1 signaling rate.

Figure 1-52 shows the relationship between assertion of the tx\_forceidle port and the transmitter buffer output on the tx\_dataout port.

**Figure 1-52. Transmitter Buffer Electrical Idle State**

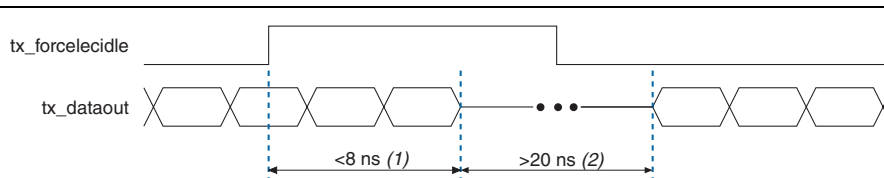

**Notes to Figure 1-52:**

- (1) The protocol requires the transmitter buffer to transition to a valid electrical idle after sending an electrical idle ordered set within 8 ns.
- (2) The protocol requires transmitter buffer to stay in electrical idle for a minimum of 20 ns for Gen1 signaling rate.

## Signal Detect at Receiver

In PIPE mode, signal detection is supported with the built-in signal threshold detection circuitry. When electrical idle inference is not enabled, the `rx_signaldetect` signal is inverted and available as `pipeelecidle` port in the PIPE interface.

## Lane Synchronization

In PIPE mode, the word aligner is configured in automatic synchronization state machine mode that complies with the PCIe specification. Table 1-16 lists the synchronization state machine parameters that implement the PCIe-compliant synchronization.

**Table 1-16. Synchronization State Machine Parameters <sup>(1)</sup>**

Parameter	Value
Number of valid synchronization (/K28.5/) code groups received to achieve synchronization	4
Number of erroneous code groups received to lose synchronization	17
Number of continuous good code groups received to reduce the error count by one	16

**Note to Table 1-16:**

(1) The word aligner supports 10-bit pattern lengths in PIPE mode.

## Clock Rate Compensation

In PIPE mode, the rate match FIFO compensates up to  $\pm 300$  ppm (600 ppm total) difference between the upstream transmitter and the local receiver reference clock. In PIPE mode, the rate match FIFO operation is compliant to the version 2.0 of the PCIe Base Specification. The PCIe protocol requires the receiver to recognize a skip (SKP) ordered set, and inserts or deletes only one SKP symbol per SKP ordered set received to prevent the rate match FIFO from overflowing or underflowing. The SKP ordered set is a /K28.5/ comma (COM) symbol followed by one to five consecutive /K28.0/ SKP symbols, which are sent by transmitter during the inter-packet gap.

The rate match operation begins after the synchronization state machine in the word aligner indicates synchronization is acquired, as indicated with logic high on `rx_syncstatus` signal. Rate match FIFO insertion and deletion events are communicated to FPGA fabric on the `pipestatus [2..0]` port from each channel.

## Low-Latency Synchronous PCIe

In PIPE mode, the Cyclone IV GX transceiver supports a lower latency in synchronous PCIe by reducing the latency across the rate match FIFO. In synchronous PCIe, the system uses a common reference clocking that gives a 0 ppm difference between the upstream transmitter's and local receiver's reference clock.



When using common reference clocking, the transceiver supports spread-spectrum clocking. For more information about the SSC support in PCIe Express (PIPE) mode, refer to the [Cyclone IV Device Data Sheet](#).

## Fast Recovery from P0s State

The PCIe protocol defines fast training sequences for bit and byte synchronization to transition from L0s to L0 (PIPE P0s to P0) power states. The PHY must acquire bit and byte synchronization when transitioning from L0s to L0 state between 16 ns to 4  $\mu$ s. Each Cyclone IV GX receiver channel has built-in fast recovery circuit that allows the receiver to meet the requirement when enabled.

## Electrical Idle Inference

In PIPE mode, the Cyclone IV GX transceiver supports inferring the electrical idle condition at each receiver instead of detecting the electrical idle condition using analog circuitry, as defined in the version 2.0 of PCIe Base Specification. The inference is supported using `rx_elecidleinfersel[2..0]` port, with valid driven values as listed in Table 1-17 in each link training and status state machine substate.

**Table 1-17. Electrical Idle Inference Conditions**

<b>rx_elecidleinfersel [2..0]</b>	<b>Link Training and Status State Machine State</b>	<b>Description</b>
3'b100	L0	Absence of <code>update_FC</code> or alternatively skip ordered set in 128 $\mu$ s window
3'b101	Recovery.RcvrCfg	Absence of TS1 or TS2 ordered set in 1280 UI interval
3'b101	Recovery.Speed when successful speed negotiation = 1'b1	Absence of TS1 or TS2 ordered set in 1280 UI interval
3'b110	Recovery.Speed when successful speed negotiation = 1'b0	Absence of an exit from electrical idle in 2000 UI interval
3'b111	Loopback.Active (as slave)	Absence of an exit from electrical idle in 128 $\mu$ s window

The electrical idle inference module drives the `pipeelecidle` signal high in each receiver channel when an electrical idle condition is inferred. The electrical idle inference module cannot detect electrical idle exit condition based on the reception of the electrical idle exit ordered set, as specified in the PCI Express (PIPE) Base Specification.



When enabled, the electrical idle inference block uses electrical idle ordered set detection from the fast recovery circuitry to drive the `pipeelecidle` signal.

## Compliance Pattern Transmission

In PIPE mode, the Cyclone IV GX transceiver supports compliance pattern transmission which requires the first /K28.5/ code group of the compliance pattern to be encoded with negative current disparity. This requirement is supported using a `tx_forcedispcompliance` port that when driven with logic high, the transmitter data on the `tx_datain` port is transmitted with negative current running disparity.

The compliance pattern is a repeating sequence of the four code groups: /K28.5/; /D21.5/; /K28.5/; /D10.2/. [Figure 1-53](#) shows the compliance pattern transmission where the `tx_forcedispcompliance` port must be asserted in the same parallel clock cycle as /K28.5/D21.5/ of the compliance pattern on `tx_datain[15..0]` port.

**Figure 1-53. Compliance Pattern Transmission Support in PCI Express (PIPE) Mode**

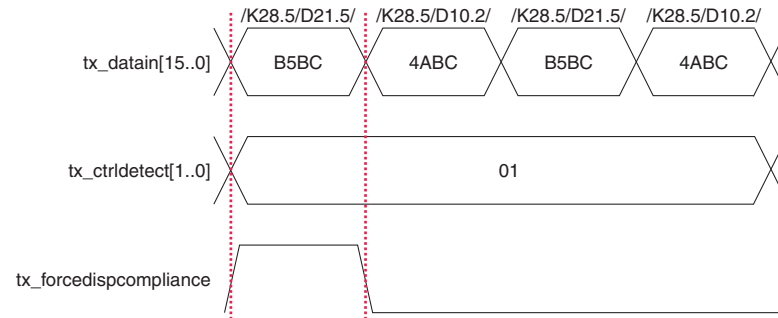

## Reset Requirement

Cyclone IV GX devices meet the PCIe reset time requirement from device power up to the link active state with the configuration schemes listed in [Table 1-17](#).

**Table 1-18. Electrical Idle Inference Conditions**

Device	Configuration Scheme	Configuration Time (ms)
EP4CGX15	Passive serial (PS)	51
EP4CGX22	PS	92
EP4CGX30 <sup>(1)</sup>	PS	92
EP4CGX50	Fast passive parallel (FPP)	41
EP4CGX75	FPP	41
EP4CGX110	FPP	70
EP4CGX150	FPP	70

**Note to [Table 1-18](#):**

(1) EP4CGX30 device in F484 package fulfills the PCIe reset time requirement using FPP configuration scheme with configuration time of 41 ms.

## GIGE Mode

GIGE mode provides the transceiver channel datapath configuration for GbE (specifically the 1000 Base-X physical layer device (PHY) standard) protocol implementation. The Cyclone IV GX transceiver provides the PMA and the following PCS functions as defined in the IEEE 802.3 specification for 1000 Base-X PHY:

- 8B/10B encoding and decoding
- synchronization

If you enabled the auto-negotiation state machine in the FPGA core with the rate match FIFO, refer to [“Clock Frequency Compensation”](#) on page 1-63.

 Cyclone IV GX transceivers do not have built-in support for some PCS functions such as auto-negotiation state machine, collision-detect, and carrier-sense. If required, you must implement these functions in a user logic or external circuits.

The 1000 Base-X PHY is defined by IEEE 802.3 standard as an intermediate or transition layer that interfaces various physical media with the media access control (MAC) in a GbE system. The 1000 Base-X PHY, which has a physical interface data rate of 1.25 Gbps consists of the PCS, PMA, and physical media dependent (PMD) layers. [Figure 1-54](#) shows the 1000 Base-X PHY in LAN layers.

**Figure 1-54. 1000 Base-X PHY in a GbE OSI Reference Model**

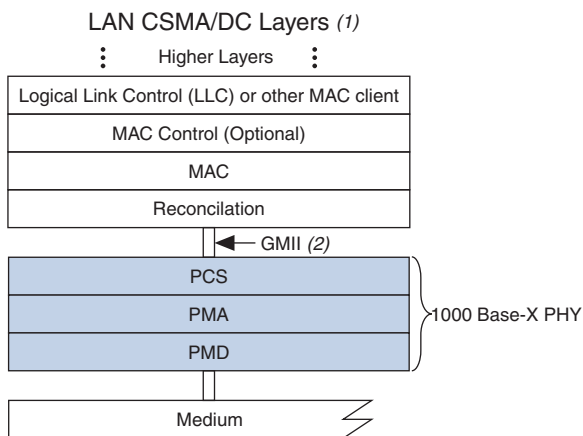

**Notes to Figure 1-54:**

- (1) CSMA/CD = Carrier-Sense Multiple Access with Collision Detection
- (2) GMII = gigabit medium independent interface

Figure 1-55 shows the transceiver channel datapath and clocking when configured in GIGE mode.

**Figure 1-55. Transceiver Channel Datapath and Clocking when Configured in GIGE Mode**

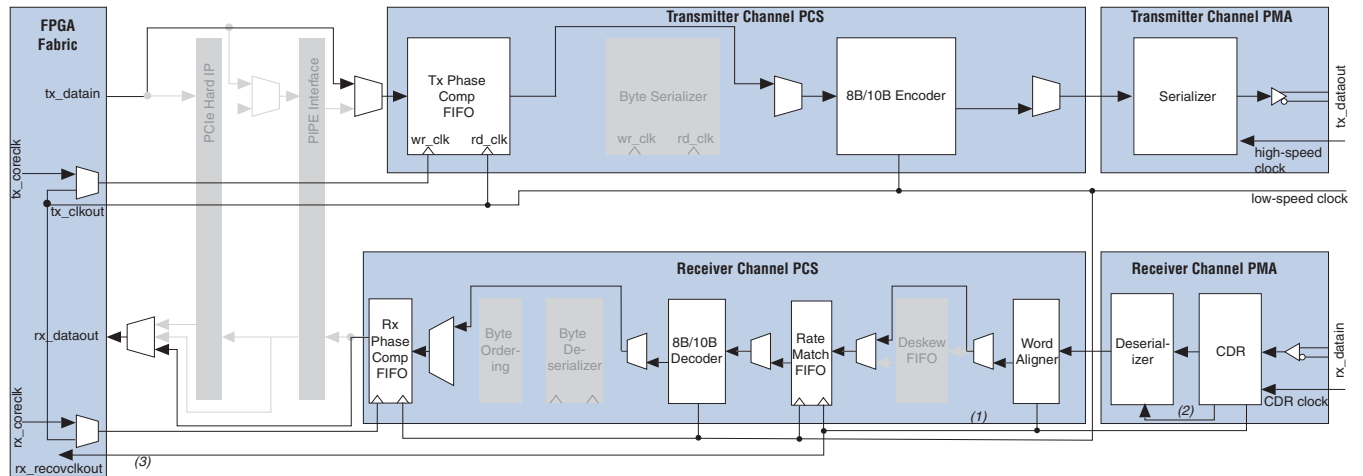

**Notes to Figure 1-55:**

- (1) Low-speed recovered clock.
- (2) High-speed recovered clock.
- (3) Optional `rx_recovclkout` port from CDR low-speed recovered clock is available for applications such as Synchronous Ethernet.

Figure 1-56 shows the transceiver configuration in GIGE mode.

**Figure 1-56. Transceiver Configuration in GIGE Mode**

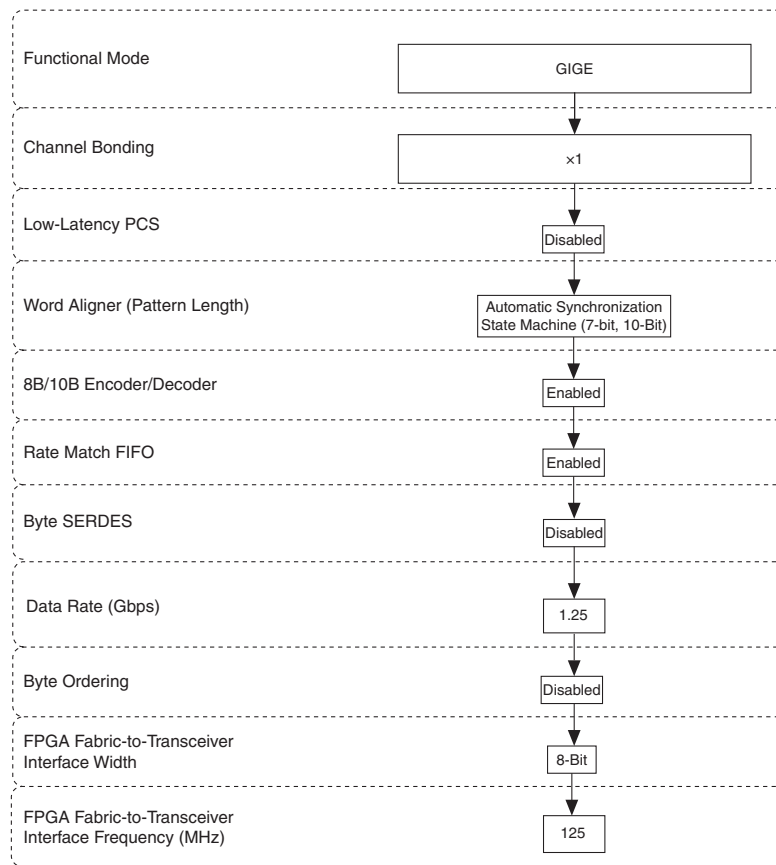

When configured in GIGE mode, three encoded comma (/K28.5/) code groups are transmitted automatically after deassertion of `tx_digitalreset` and before transmitting user data on the `tx_datain` port. This could affect the synchronization state machine behavior at the receiver.

Depending on when you start transmitting the synchronization sequence, there could be an even or odd number of encoded data (/Dx.y/) code groups transmitted between the last of the three automatically sent /K28.5/ code groups and the first /K28.5/ code group of the synchronization sequence. If there is an even number of /Dx.y/ code groups received between these two /K28.5/ code groups, the first /K28.5/ code group of the synchronization sequence begins at an odd code group boundary. An IEEE802.3-compliant GIGE synchronization state machine treats this as an error condition and goes into the Loss-of-Sync state.

Figure 1-57 shows an example of even numbers of  $/Dx.y/$  between the last automatically sent  $/K28.5/$  and the first user-sent  $/K28.5/$ . The first user-sent  $/K28.5/$  code group received at an odd code group boundary in cycle  $n + 3$  takes the receiver synchronization state machine in Loss-of-Sync state. The first synchronization ordered-set  $/K28.5/Dx.y/$  in cycles  $n + 3$  and  $n + 4$  is discounted and three additional ordered sets are required for successful synchronization.

**Figure 1-57. Example of Reset Condition in GIGE Mode**

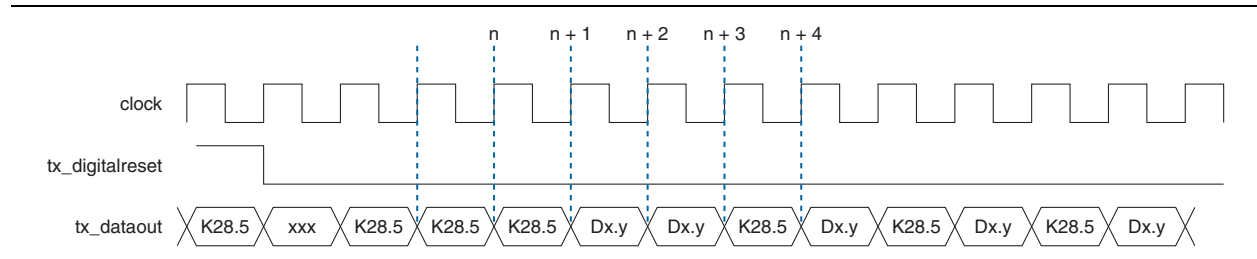

### Running Disparity Preservation with Idle Ordered Set

During idle ordered sets transmission in GIGE mode, the transmitter ensures a negative running disparity at the end of an idle ordered set. Any  $/Dx.y/$ , except for  $/D21.5/$  (part of  $/C1/$  ordered set) or  $/D2.2/$  (part of  $/C2/$  ordered set) following a  $/K28.5/$  is automatically replaced with either of the following:

- A  $/D5.6/$  ( $/I1/$  ordered set) if the running disparity before  $/K28.5/$  is positive
- A  $/D16.2/$  ( $/I2/$  ordered set) if the running disparity before  $/K28.5/$  is negative

### Lane Synchronization

In GIGE mode, the word aligner is configured in automatic synchronization state machine mode that complies with the IEEE P802.3ae standard. A synchronization ordered set is a  $/K28.5/$  code group followed by an odd number of valid  $/Dx.y/$  code groups. Table 1-19 lists the synchronization state machine parameters that implements the GbE-compliant synchronization.

**Table 1-19. Synchronization State Machine Parameters <sup>(1)</sup>**

Parameter	Value
Number of valid synchronization ordered sets received to achieve synchronization	3
Number of erroneous code groups received to lose synchronization	4
Number of continuous good code groups received to reduce the error count by one	4

**Note to Table 1-19:**

(1) The word aligner supports 7-bit and 10-bit pattern lengths in GIGE mode.

## Clock Frequency Compensation

In GIGE mode, the rate match FIFO compensates up to  $\pm 100$  ppm (200 ppm total) difference between the upstream transmitter and the local receiver reference clock. The GIGE protocol requires the transmitter to send idle ordered sets /I1/ (/K28.5/D5.6/) and /I2/ (/K28.5/D16.2/) during inter-packet gaps, adhering to the rules listed in the IEEE 802.3 specification.

The rate match operation begins after the synchronization state machine in the word aligner indicates synchronization has been acquired by driving the rx\_syncstatus signal high. The rate match FIFO deletes or inserts both symbols of the /I2/ ordered sets (/K28.5/ and /D16.2/) to prevent the rate match FIFO from overflowing or underflowing. It can insert or delete as many /I2/ ordered sets as necessary to perform the rate match operation.

 If you have the auto-negotiation state machine in the FPGA, note that the rate match FIFO is capable of inserting or deleting the first two bytes (/K28.5//D2.2/) of /C2/ ordered sets during auto-negotiation. However, the insertion or deletion of the first two bytes of /C2/ ordered sets can cause the auto-negotiation link to fail. For more information, refer to the [Altera Knowledge Base Support Solution](#).

The status flags rx\_rmifodatadeleted and rx\_rmifodatainserted to indicate rate match FIFO deletion and insertion events, respectively, are forwarded to the FPGA fabric. These two flags are asserted for two clock cycles for each deleted and inserted /I2/ ordered set.

Figure 1-58 shows an example of rate match FIFO deletion where three symbols must be deleted. Because the rate match FIFO can only delete /I2/ ordered sets, it deletes two /I2/ ordered sets (four symbols deleted).

**Figure 1-58. Example of Rate Match FIFO Deletion in GIGE Mode**

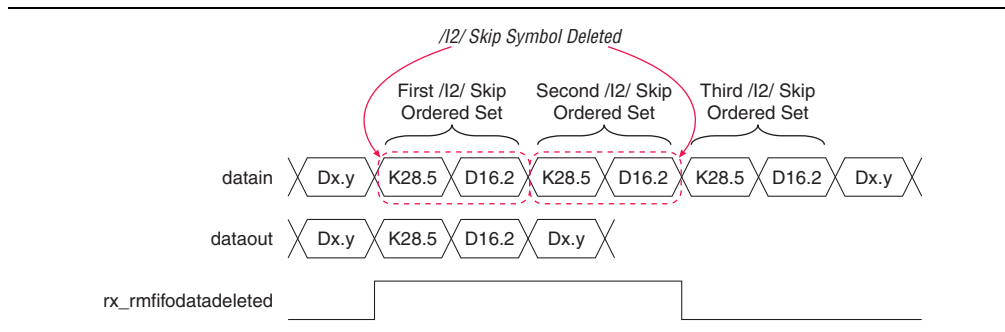
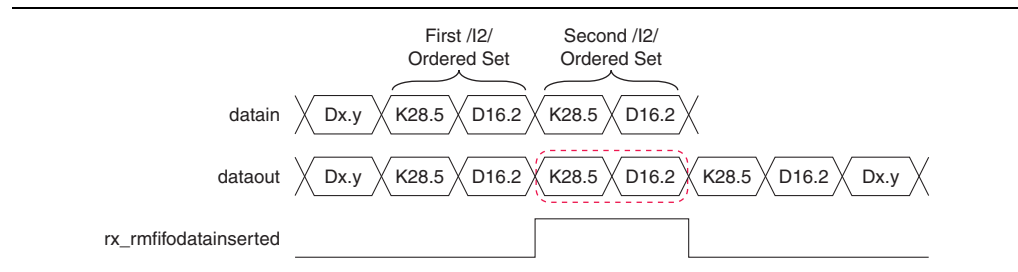



Figure 1–59 shows an example of rate match FIFO insertion in the case where one symbol must be inserted. Because the rate match FIFO can only insert  $/I2/$  ordered sets, it inserts one  $/I2/$  ordered set (two symbols inserted).

**Figure 1–59. Example of Rate Match FIFO Insertion in GIGE Mode**



 The rate match FIFO does not insert or delete code groups automatically to overcome FIFO empty or full conditions. In this case, the rate match FIFO asserts the `rx_rmifofull` and `rx_rmifoempty` flags for at least two recovered clock cycles to indicate rate match FIFO full and empty conditions, respectively. You must then assert the `rx_digitalreset` signal to reset the receiver PCS blocks.

## Serial RapidIO Mode

Serial RapidIO mode provides the non-bonded ( $\times 1$ ) transceiver channel datapath configuration for SRIO protocol implementation. The Cyclone IV GX transceiver provides the PMA and the following PCS functions:

- 8B/10B encoding and decoding
- lane synchronization state machine

 Cyclone IV GX transceivers do not have built-in support for some PCS functions such as pseudo-random idle sequence generation and lane alignment in  $\times 4$  bonded channel configuration. If required, you must implement these functions in a user logics or external circuits.

The RapidIO Trade Association defines a high-performance, packet-switched interconnect standard to pass data and control information between microprocessors, digital signals, communications, network processes, system memories, and peripheral devices. The SRIO physical layer specification defines serial protocol running at 1.25 Gbps, 2.5 Gbps, and 3.125 Gbps in either single-lane ( $\times 1$ ) or bonded four-lane ( $\times 4$ ) at each line rate. Cyclone IV GX transceivers support single-lane ( $\times 1$ ) configuration at all three line rates. Four  $\times 1$  channels configured in Serial RapidIO mode can be instantiated to achieve one non-bonded  $\times 4$  SRIO link. When implementing four  $\times 1$  SRIO channels, the receivers do not have lane alignment or deskew capability.

Figure 1-60 shows the transceiver channel datapath and clocking when configured in Serial RapidIO mode.

**Figure 1-60. Transceiver Channel Datapath and Clocking when Configured in Serial RapidIO Mode**

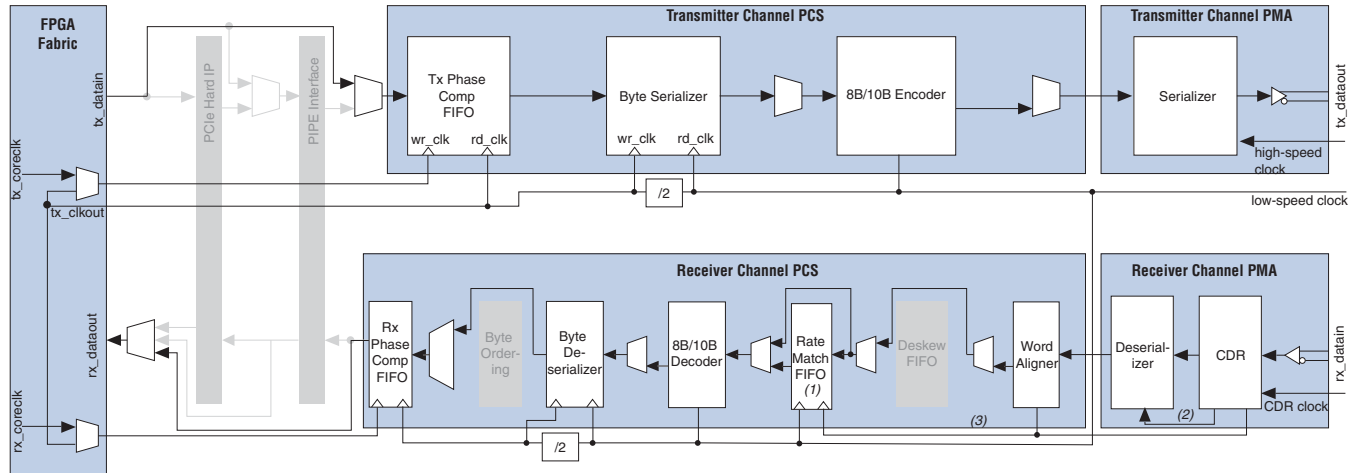

**Notes to Figure 1-60:**

- (1) Optional rate match FIFO.
- (2) High-speed recovered clock.
- (3) Low-speed recovered clock.

Figure 1-61 shows the transceiver configuration in Serial RapidIO mode.

**Figure 1-61. Transceiver Configuration in Serial RapidIO Mode**

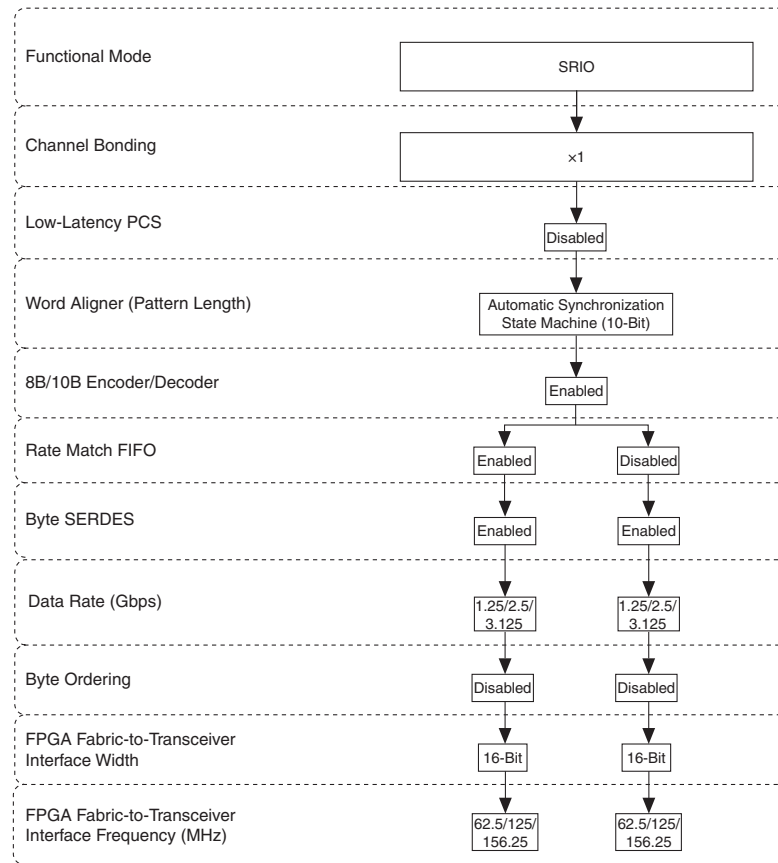

## Lane Synchronization

In Serial RapidIO mode, the word aligner is compliant to the SRIO Specification 1.3 and is configured in automatic synchronization state machine mode with the parameter settings as listed in Table 1-20.

**Table 1-20. Synchronization State Machine Parameters <sup>(1)</sup>**

Parameter	Value
Number of valid synchronization (/K28.5/) code groups received to achieve synchronization	127
Number of erroneous code groups received to lose synchronization	3
Number of continuous good code groups received to reduce the error count by one	255

**Note to Table 1-20:**

(1) The word aligner supports 10-bit pattern lengths in SRIO mode.

## Clock Frequency Compensation

In Serial RapidIO mode, the rate match FIFO compensates up to  $\pm 100$  ppm (200 ppm total) difference between the upstream transmitter and the local receiver reference clock.

Rate matcher is an optional block available for selection in Serial RapidIO mode. However, this block is not fully compliant to the SRIO specification. When enabled in the ALTGX MegaWizard Plug-In Manager, the default settings are:

- control pattern 1 = K28.5 with positive disparity
- skip pattern 1 = K29.7 with positive disparity
- control pattern 2 = K28.5 with negative disparity
- skip pattern 2 = K29.7 with negative disparity

When enabled, the rate match FIFO operation begins after the link is synchronized (indicated by assertion of `rx_syncstatus` from the word aligner). When the rate matcher receives either of the two 10-bit control patterns followed by the respective 10-bit skip pattern, it inserts or deletes the 10-bit skip pattern as necessary to avoid the rate match FIFO from overflowing or under-running. The rate match FIFO can delete/insert a maximum of one skip pattern from a cluster.



The rate match FIFO may perform multiple insertion or deletion if the ppm difference is more than the allowable 200 ppm range. Ensure that the ppm difference in your system is less than 200 ppm.

## XAUI Mode

XAUI mode provides the bonded ( $\times 4$ ) transceiver channel datapath configuration for XAUI protocol implementation. The Cyclone IV GX transceivers configured in XAUI mode provides the following functions:

- XGMII-to-PCS code conversion at transmitter datapath
- PCS-to-XGMII code conversion at receiver datapath
- channel deskewing of four lanes
- 8B/10B encoding and decoding
- IEEE P802.3ae-compliant synchronization state machine
- clock rate compensation

The XAUI is a self-managed interface to transparently extend the physical reach of the XGMII between the reconciliation sublayer and the PHY layer in the 10 Gbps LAN as shown in [Figure 1-62](#). The XAUI interface consists of four lanes, each running at 3.125 Gbps with 8B/10B encoded data for a total of actual 10 Gbps data throughput. At the transmit side of the XAUI interface, the data and control characters are

converted within the XGMII extender sublayer into an 8B/10B encoded data stream. Each data stream is then transmitted across a single differential pair running at 3.125 Gbps. At the XAUI receiver, the incoming data is decoded and mapped back to the 32-bit XGMII format. This provides a transparent extension of the physical reach of the XGMII and also reduces the interface pin count.

**Figure 1-62. XAUI in 10 Gbps LAN Layers**

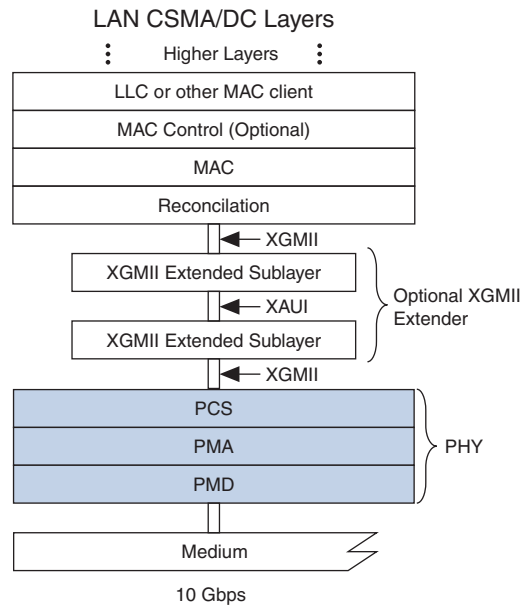

XAUI functions as a self-managed interface because code group synchronization, channel deskew, and clock domain decoupling is handled with no upper layer support requirements. This functionality is based on the PCS code groups that are used during the inter-packet gap time and idle periods.

Figure 1-63 shows the transceiver channel datapath and clocking when configured in XAUI mode.

Figure 1-63. Transceiver Channel Datapath and Clocking when Configured in XAUI Mode

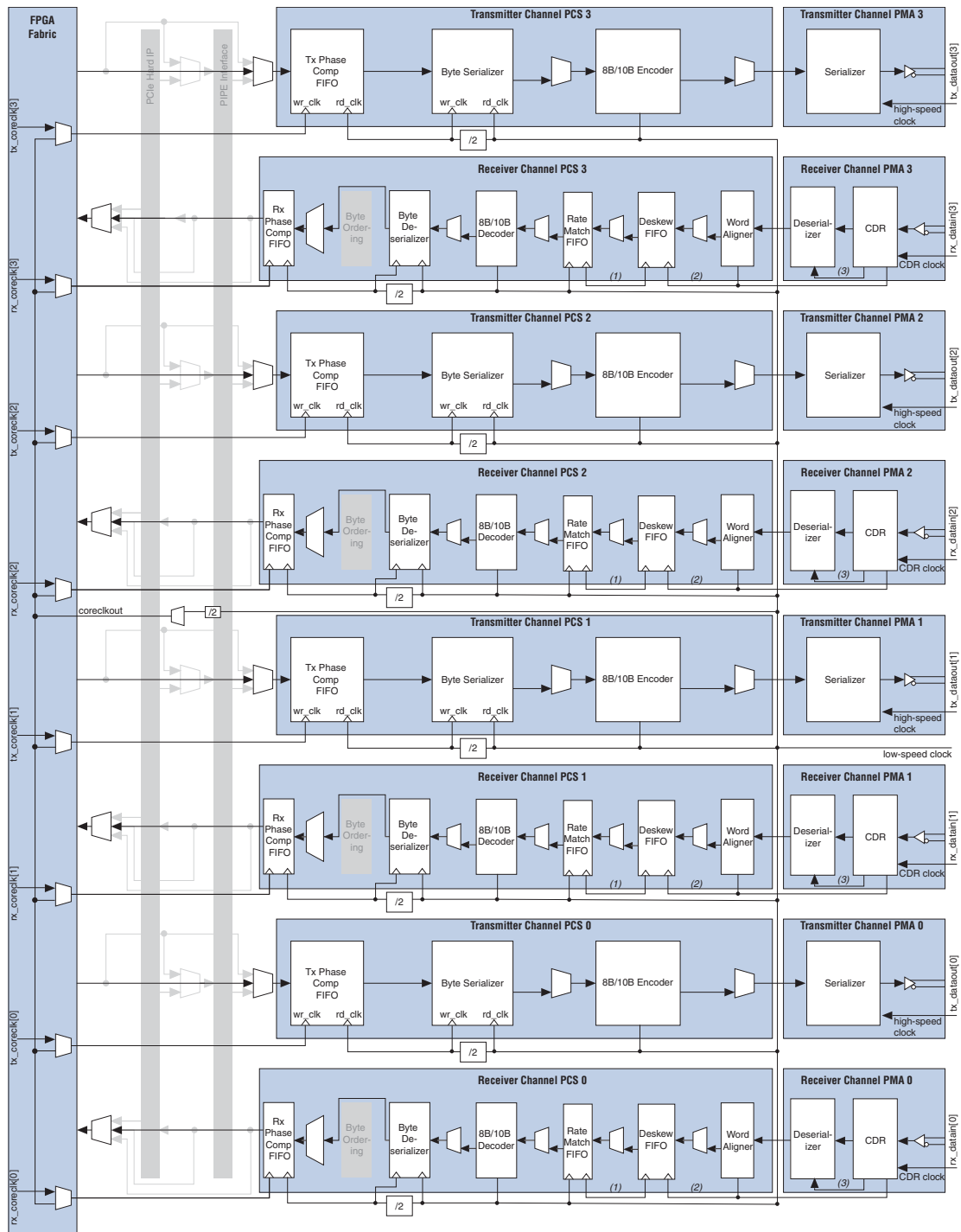

Notes to Figure 1-63:

- (1) Channel 1 low-speed recovered clock.
- (2) Low-speed recovered clock.
- (3) High-speed recovered clock.

Figure 1-64 shows the transceiver configuration in XAUI mode.

**Figure 1-64. Transceiver Configuration in XAUI Mode**

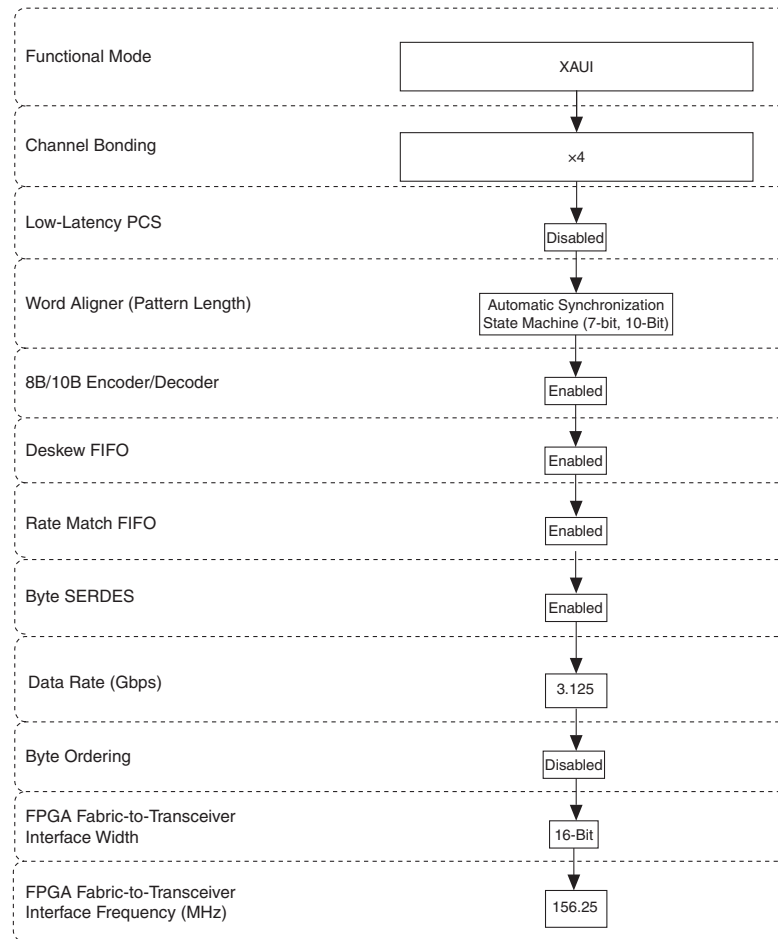

## XGMII and PCS Code Conversions

In XAUI mode, the 8B/10B encoder in the transmitter datapath maps various 8-bit XGMII codes to 10-bit PCS code groups as listed in Table 1-21.

**Table 1-21. XGMII Character to PCS Code Groups Mapping (Part 1 of 2)**

XGMII TXC <sup>(1)</sup>	XGMII TXD <sup>(2), (3)</sup>	PCS Code Group	Description
0	00 through FF	Dxx,y	Normal data transmission
1	07	K28.0, K28.3, or K28.5	Idle in   I
1	07	K28.5	Idle in   T
1	9C	K28.4	Sequence
1	FB	K27.7	Start
1	FD	K29.7	Terminate
1	FE	K30.7	Error

**Table 1–21. XGMII Character to PCS Code Groups Mapping (Part 2 of 2)**

XGMII TXC <sup>(1)</sup>	XGMII TXD <sup>(2), (3)</sup>	PCS Code Group	Description
1	Any other value	K30.7	Invalid XGMII character

**Notes to Table 1–21:**

- (1) Equivalent to tx\_ctrlenable port.
- (2) Equivalent to 8-bit input data to 8B/10B encoder.
- (3) The values in XGMII TXD column are in hexadecimal.

8B/10B decoder in the receiver datapath maps received PCS code groups into specific 8-bit XGMII codes as listed in Table 1–22.

**Table 1–22. PCS Code Groups to XGMII Character Mapping**

XGMII RXC <sup>(1)</sup>	XGMII RXD <sup>(2), (3)</sup>	PCS Code Group	Description
0	00 through FF	Dxx,y	Normal data transmission
1	07	K28.0, K28.3, or K28.5	Idle in
1	07	K28.5	Idle in   T
1	9C	K28.4	Sequence
1	FB	K27.7	Start
1	FD	K29.7	Terminate
1	FE	K30.7	Error
1	FE	Invalid code group	Received code group

**Notes to Table 1–22:**

- (1) Equivalent to rx\_ctrlenable port.
- (2) Equivalent to 8-bit input data to 8B/10B encoder.
- (3) The values in XGMII RXD column are in hexadecimal.

## Channel Deskewing

The deskew FIFO in each of the four lanes expects to receive /A/ code group simultaneously on all four channels during the inter-packet gap, as required by XAUI protocol. The skew introduced in the physical medium and the receiver channels might cause the /A/ code group to be received misaligned with respect to each other.

The deskew FIFO works to align the /A/ code group across the four channels, which operation is compliant to the PCS deskew state machine diagram specified in clause 48 of the IEEE P802.3ae specification. The deskew operation begins after link synchronization is achieved on all four channels as indicated by the word aligner in each channel. The following are the deskew FIFO operations:

- Until the first /A/ code group is received, the deskew FIFO read and write pointers in each channel are not incremented.
- After the first /A/ code group is received, the write pointer starts incrementing for each word received but the read pointer is frozen.
- When all the four channels received the /A/ code group within 10 recovered clock cycles of each other, the read pointer of all four deskew FIFOs is released simultaneously, aligning the /A/ code group of all four channels in a column.

- Channel alignment is acquired if three additional aligned `||A||` columns are observed at the output of the deskew FIFOs of the four channels after alignment of the first `||A||` column.
- Channel alignment is indicated by the assertion of `rx_channelaligned` signal.
- After acquiring channel alignment, if four misaligned `||A||` columns are seen at the output of the deskew FIFOs in all four channels with no aligned `||A||` columns in between, the `rx_channelaligned` signal is deasserted, indicating loss of channel alignment.

Figure 1-65 shows lane skew at the receiver input and how the deskew FIFO uses the `/A/` code group to align the channels.

**Figure 1-65. Deskew FIFO—Lane Skew at the Receiver Input**

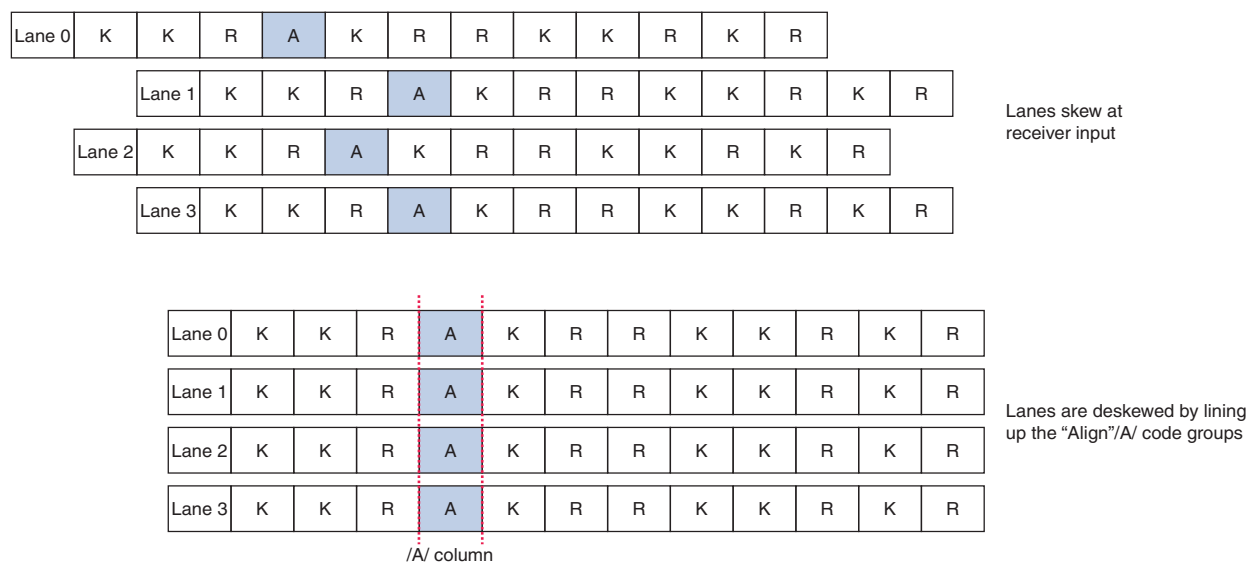

## Lane Synchronization

In XAUI mode, the word aligner is configured in automatic synchronization state machine mode that is compliant to the PCS synchronization state diagram specified in clause 48 of the IEEE P802.3ae specification. Table 1-23 lists the synchronization state machine parameters that implements the lane synchronization in XAUI mode.

**Table 1-23. Synchronization State Machine Parameters <sup>(1)</sup>**

Parameter	Value
Number of valid synchronization ( <code>/K28.5/</code> ) code groups received to achieve synchronization	4
Number of erroneous code groups received to lose synchronization	4
Number of continuous good code groups received to reduce the error count by one	4

**Note to Table 1-23:**

- (1) The word aligner supports 7-bit and 10-bit pattern lengths in XAUI mode.

## Clock Rate Compensation

In XAUI mode, the rate match FIFO compensates up to  $\pm 100$  ppm (200 ppm total) difference between the upstream transmitter and the local receiver reference clock. The XAUI protocol requires the transmitter to send /R/ (/K28.0/) code groups simultaneously on all four lanes (denoted as ||R|| column) during inter-packet gaps, adhering to rules listed in the IEEE P802.3ae specification.

The rate match operation begins after `rx_syncstatus` and `rx_channelaligned` are asserted. The `rx_syncstatus` signal is from the word aligner, indicating that synchronization is acquired on all four channels, while `rx_channelaligned` signal is from the deskew FIFO, indicating channel alignment.

The rate match FIFO looks for the ||R|| column (simultaneous /R/ code groups on all four channels) and deletes or inserts ||R|| columns to prevent the rate match FIFO from overflowing or under running. The rate match FIFO can insert or delete as many ||R|| columns as necessary to perform the rate match operation.

The `rx_rmfiodeleted` and `rx_rmfifoinserted` flags that indicate rate match FIFO deletion and insertion events, respectively, are forwarded to the FPGA fabric. If an ||R|| column is deleted, the `rx_rmfiodeleted` flag from each of the four channels goes high for one clock cycle per deleted ||R|| column. If an ||R|| column is inserted, the `rx_rmfifoinserted` flag from each of the four channels goes high for one clock cycle per inserted ||R|| column.



The rate match FIFO does not insert or delete code groups automatically to overcome FIFO empty or full conditions. In this case, the rate match FIFO asserts the `rx_rmfifoempty` and `rx_rmfifofull` flags for at least three recovered clock cycles to indicate rate match FIFO full and empty conditions, respectively. You must then assert the `rx_digitalreset` signal to reset the receiver PCS blocks.

## Deterministic Latency Mode

Deterministic Latency mode provides the transceiver configuration that allows no latency uncertainty in the datapath and features to strictly control latency variation. This mode supports non-bonded ( $\times 1$ ) and bonded ( $\times 4$ ) channel configurations, and is typically used to support CPRI and OBSAI protocols that require accurate delay measurements along the datapath. The Cyclone IV GX transceivers configured in Deterministic Latency mode provides the following features:

- registered mode phase compensation FIFO
- receive bit-slip indication
- transmit bit-slip control
- PLL PFD feedback

Figure 1-66 shows the transceiver channel datapath and clocking when configured in deterministic latency mode.

**Figure 1-66. Transceiver Channel Datapath and Clocking when Configured in Deterministic Latency Mode**

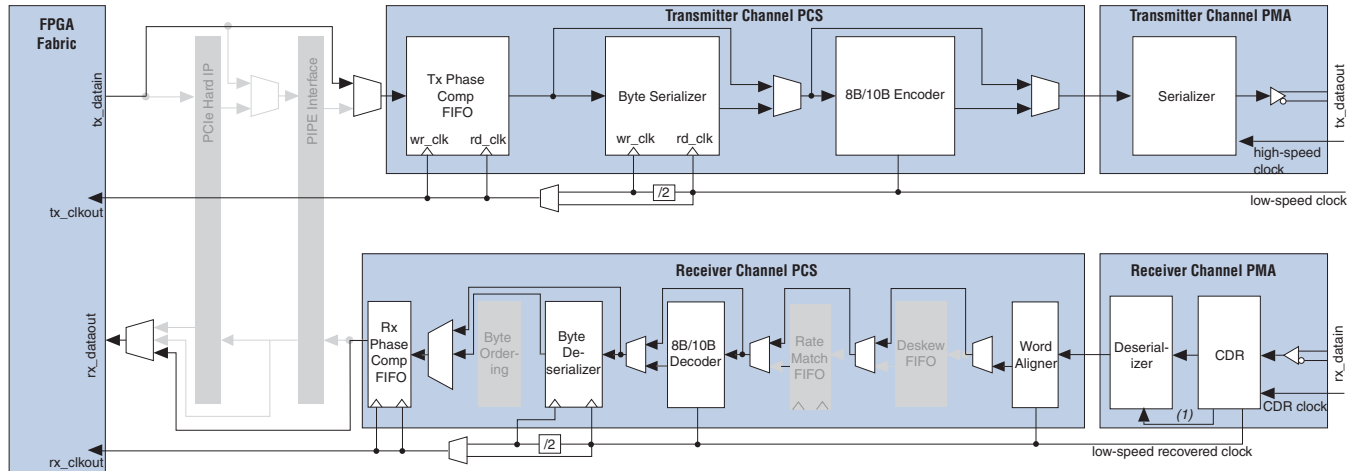

**Note to Figure 1-66:**

(1) High-speed recovered clock.

Figure 1-67 shows the transceiver configuration in Deterministic Latency mode.

**Figure 1-67. Transceiver Configuration in Deterministic Latency Mode**

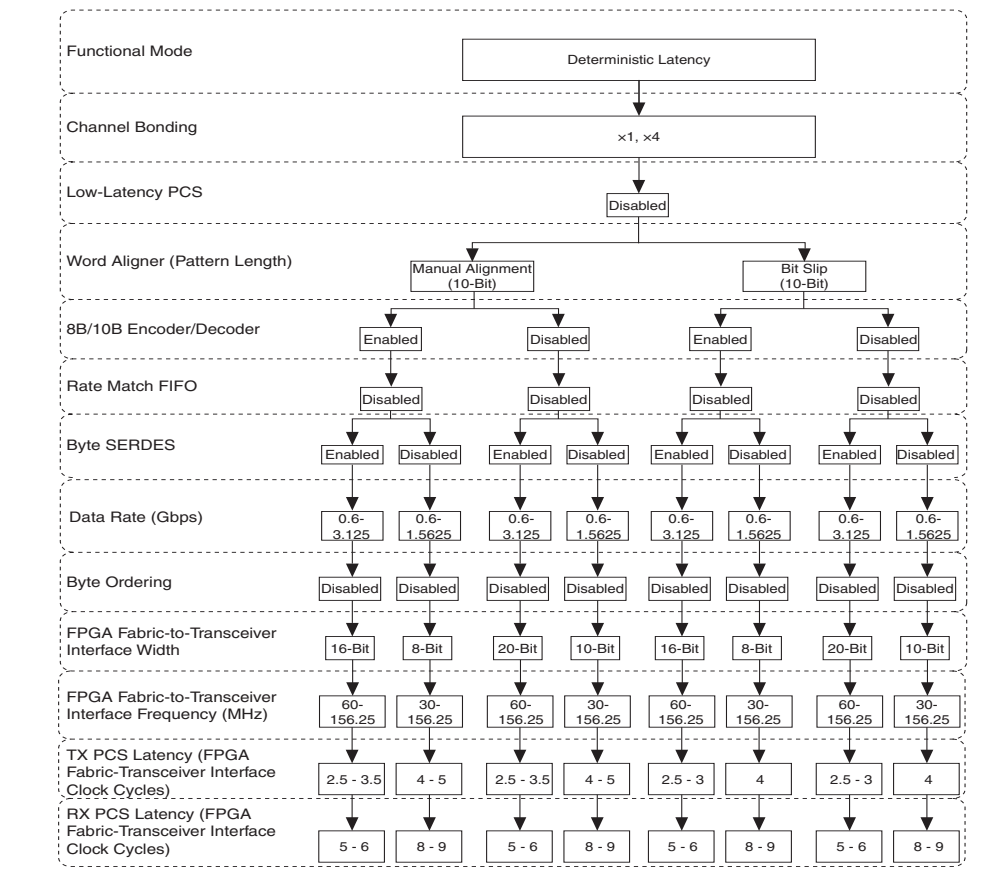

Both CPRI and OBSAI protocols define the serial interface connecting the base station component (specifically channel cards) and remote radio heads (specifically radio frequency cards) in a radio base station system with fiber optics. The protocols require the accuracy of round trip delay measurement for single-hop and multi-hop connections to be within  $\pm 16.276$  ns. The Cyclone IV GX transceivers support the following CPRI and OBSAI line rates using Deterministic Latency mode:

- CPRI—614.4 Mbps, 1.2288 Gbps, 2.4576 Gbps, and 3.072 Gbps
- OBSAI—768 Mbps, 1.536 Gbps, and 3.072 Gbps

 For more information about deterministic latency implementation, refer to *AN 610: Implementing Deterministic Latency for CPRI and OBSAI Protocols in Stratix IV, HardCopy IV, Arria II GX, and Cyclone IV Devices*.

### Registered Mode Phase Compensation FIFO

In Deterministic Latency mode, the RX phase compensation FIFO is set to registered mode while the TX phase compensation FIFO supports optional registered mode. When set into registered mode, the phase compensation FIFO acts as a register and eliminates the latency uncertainty through the FIFOs.

## Receive Bit-Slip Indication

The number of bits slipped in the word aligner for synchronization in manual alignment mode is provided with the `rx_bitslipboundaryselectout[4..0]` signal. For example, if one bit is slipped in word aligner to achieve synchronization, the output on `rx_bitslipboundaryselectout[4..0]` signal shows a value of 1 (5'00001). The information from this signal helps in latency calculation through the receiver as the number of bits slipped in the word aligner varies at each synchronization.

## Transmit Bit-Slip Control

The transmitter datapath supports bit-slip control to delay the serial data transmission by a number of specified bits in PCS with `tx_bitslipboundaryselect[4..0]` port. With 8- or 10-bit channel width, the transmitter supports zero to nine bits of data slip. This feature helps to maintain a fixed round trip latency by compensating latency variation from word aligner when providing the appropriate values on `tx_bitslipboundaryselect[4..0]` port based on values on `rx_bitslipboundaryselectout[4..0]` signal.

## PLL PFD feedback

In Deterministic Latency mode, when transmitter input reference clock frequency is the same as the low-speed clock, the PLL that clocks the transceiver supports PFD feedback. When enabled, the PLL compensates for delay uncertainty in the low-speed clock (`tx_clkout` in  $\times 1$  configuration or `coreclkout` in  $\times 4$  configuration) path relative to input reference and the transmitter datapath latency is fixed relative to the transmitter input reference clock.

## SDI Mode

SDI mode provides the non-bonded ( $\times 1$ ) transceiver channel datapath configuration for HD- and 3G-SDI protocol implementations.

Cyclone IV GX transceivers configured in SDI mode provides the serialization and deserialization functions that supports the SDI data rates as listed in [Table 1-24](#).

**Table 1-24. Supported SDI Data Rates**

SMPTE Standard <sup>(1)</sup>	Configuration	Data Rate (Mbps)	FPGA Fabric-to-Transceiver Width	Byte SERDES Usage
292M	High definition (HD)	1483.5	20-bit	Used
			10-bit	Not used
		1485	20-bit	Used
			10-bit	Not used
424M	Third-generation (3G)	2967	20-bit	Used
		2970		

**Note to Table 1-24:**

(1) Society of Motion Picture and Television Engineers (SMPTE).



SDI functions such as scrambling/de-scrambling, framing, and cyclic redundancy check (CRC) must be implemented in the user logic.

Figure 1-68 shows the transceiver channel datapath and clocking when configured in SDI mode.

**Figure 1-68. Transceiver Channel Datapath and Clocking when Configured in SDI Mode**

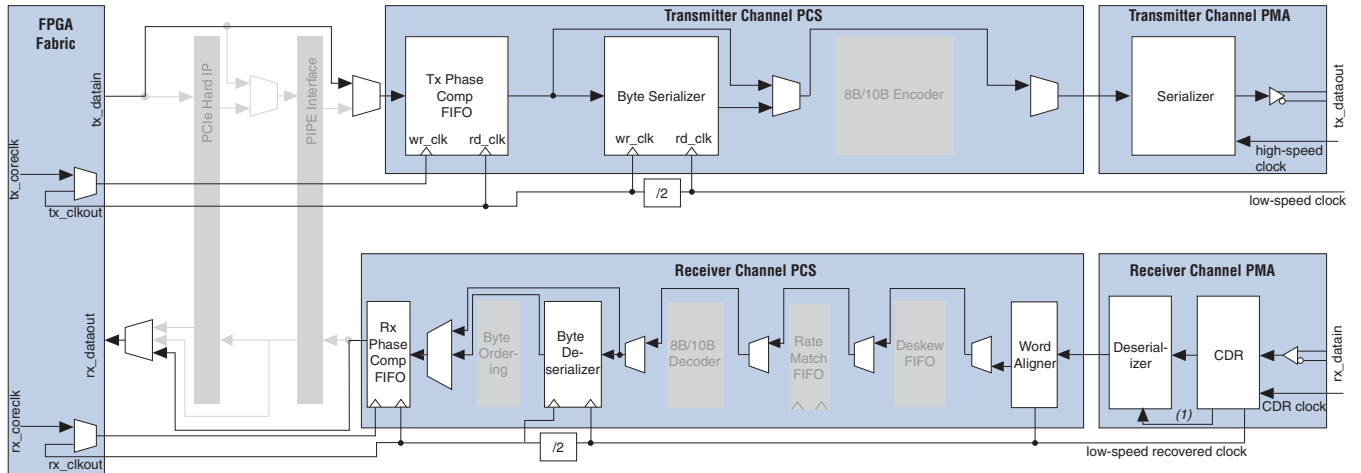

**Note to Figure 1-68:**

- (1) High-speed recovered clock.

Figure 1-69 shows the transceiver configuration in SDI mode.

**Figure 1-69. Transceiver Configuration in SDI Mode**

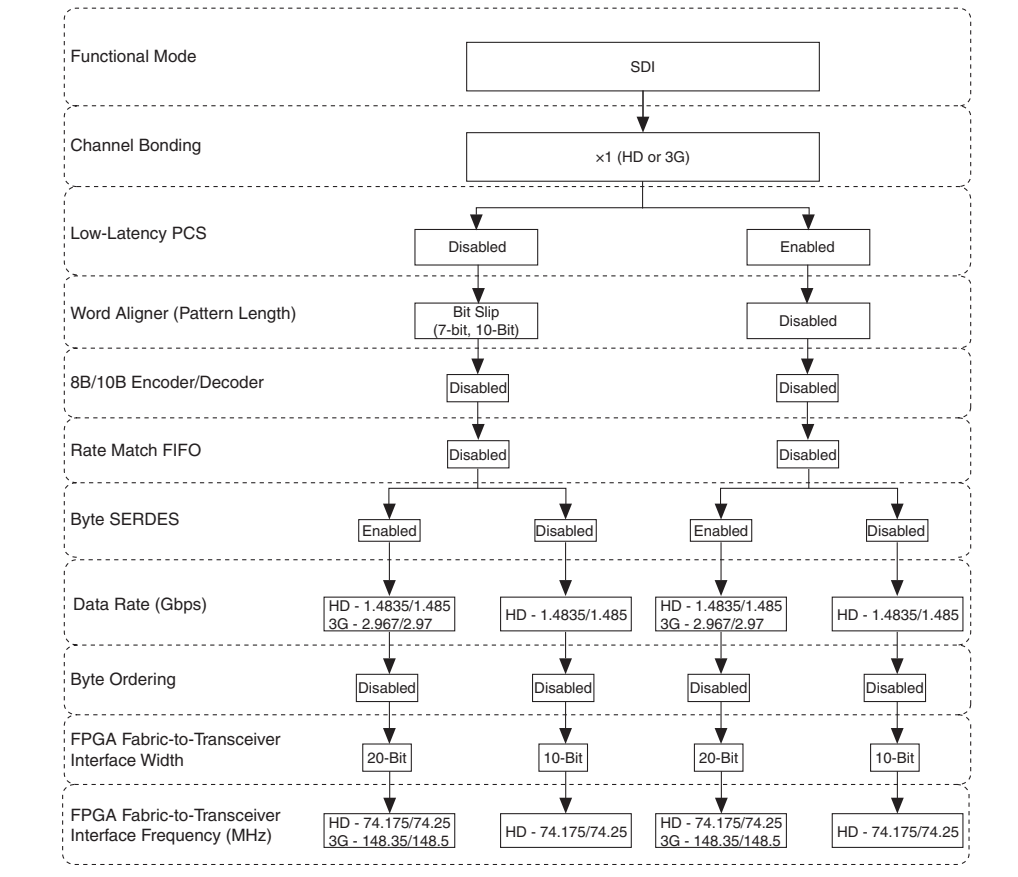

Altera recommends driving `rx_bitslip` port low in configuration where low-latency PCS is not enabled. In SDI systems, the word alignment and framing occurs after descrambling, which is implemented in the user logic. The word alignment therefore is not useful, and keeping `rx_bitslip` port low avoids the word aligner from inserting bits in the received data stream.

## Loopback

Cyclone IV GX devices provide three loopback options that allow you to verify the operation of different functional blocks in the transceiver channel. The following loopback modes are available:

- reverse parallel loopback (available only for PIPE mode)
- serial loopback (available for all modes except PIPE mode)
- reverse serial loopback (available for all modes except XAUI mode)

In each loopback mode, all transmitter buffer and receiver buffer settings are available if the buffers are active, unless stated otherwise.

## Reverse Parallel Loopback

The reverse parallel loopback option is only available for PIPE mode. In this mode, the received serial data passes through the receiver CDR, deserializer, word aligner, and rate match FIFO before looping back to the transmitter serializer and transmitted out through the TX buffer, as shown in Figure 1-70. The received data is also available to the FPGA fabric. This loopback mode is compliant with version 2.00 of the *PHY Interface for the PCI Express Architecture* specification.

To enable the reverse parallel loopback mode, assert the tx\_detectrxloopback port in P0 power state.

**Figure 1-70. PIPE Reverse Parallel Loopback Path (1)**

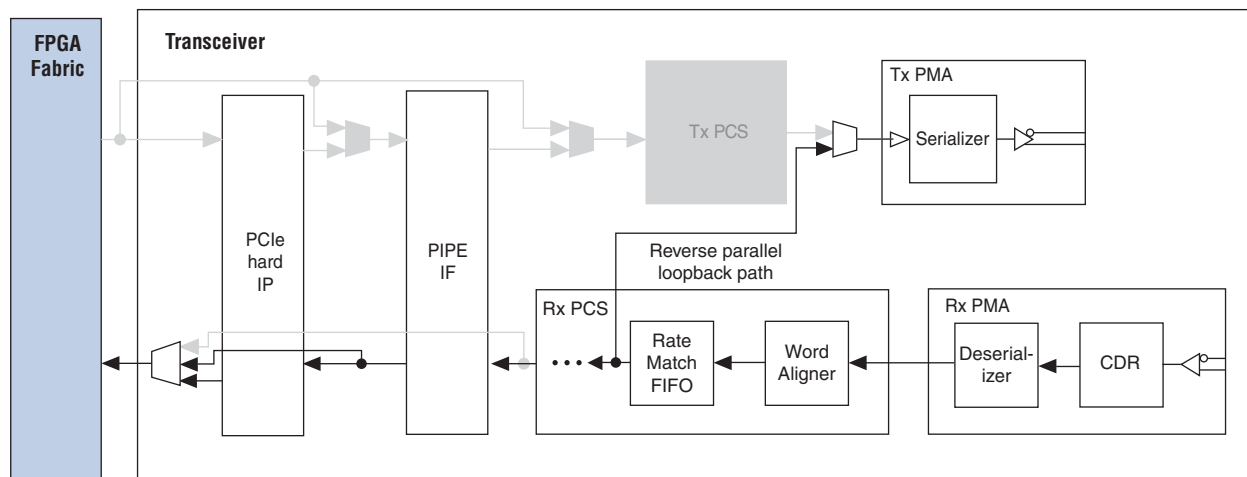

**Note to Figure 1-70:**

(1) Grayed-Out Blocks are Not Active in this mode.

## Serial Loopback

The serial loopback option is available for all functional modes except PIPE mode. In this mode, the data from the FPGA fabric passes through the transmitter channel and looped back to the receiver channel, bypassing the receiver buffer, as shown in Figure 1-71. The received data is available to the FPGA logic for verification. The receiver input buffer is not active in this mode. With this option, you can check the operation of all enabled PCS and PMA functional blocks in the transmitter and receiver channels.

The transmitter channel sends the data to both the serial output port and the receiver channel. The differential output voltage on the serial ports is based on the selected  $V_{OD}$  settings. The data is looped back to the receiver CDR and is retimed through different clock domains. You must provide an alignment pattern for the word aligner to enable the receiver channel to retrieve the byte boundary.

- Serial loopback mode can only be dynamically enabled or disabled during user mode by performing a dynamic channel reconfiguration.

**Figure 1-71. Serial Loopback Path (1)**

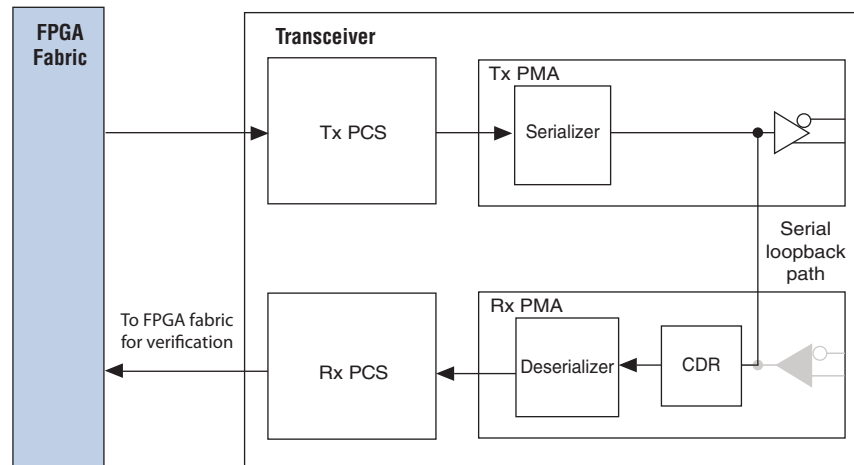

**Note to Figure 1-71:**

(1) Grayed-Out Blocks are Not Active in this mode.

## Reverse Serial Loopback

The reverse serial loopback mode is available for all functional modes except for XAUI mode. The two reverse serial loopback options from the receiver to the transmitter are:

- Pre-CDR mode where data received through the RX input buffer is looped back to the TX output buffer using the **Reverse serial loopback (pre-CDR)** option
- Post-CDR mode where retimed data through the receiver CDR from the RX input buffer is looped back to the TX output buffer using the **Reverse serial loopback** option

The received data is also available to the FPGA logic. In the transmitter channel, only the transmitter buffer is active.

- The transmitter pre-emphasis feature is not available in reverse serial loopback (pre-CDR) mode.
- Reverse serial loopback modes can only be dynamically enabled or disabled during user mode by performing a dynamic channel reconfiguration.

Figure 1-72 shows the two paths in reverse serial loopback mode.

Figure 1-72. Reverse Serial Loopback (1)

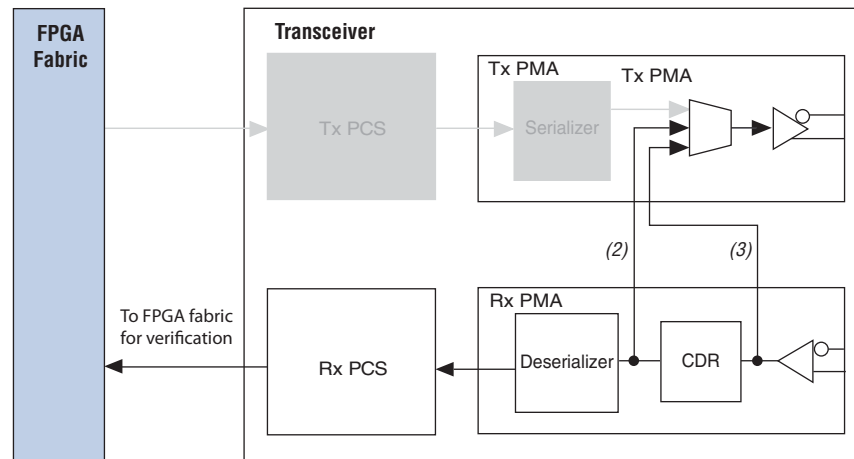

Notes to Figure 1-72:

- (1) Grayed-Out Blocks are Not Active in this mode.
- (2) Post-CDR reverse serial loopback path.
- (3) Pre-CDR reverse serial loopback path.

## Self Test Modes

Each transceiver channel in the Cyclone IV GX device contains modules for pattern generator and verifier. Using these built-in features, you can verify the functionality of the functional blocks in the transceiver channel without requiring user logic. The self test functionality is provided as an optional mechanism for debugging transceiver channels.

There are three types of supported pattern generators and verifiers:

- Built-in self test (BIST) incremental data generator and verifier—test the complete transmitter PCS and receiver PCS datapaths for bit errors with parallel loopback before the PMA blocks.
- Pseudo-random binary sequence (PRBS) generator and verifier—the PRBS generator and verifier interface with the serializer and deserializer in the PMA blocks. The advantage of using a PRBS data stream is that the randomness yields an environment that stresses the transmission medium. In the data stream, you can observe both random jitter and deterministic jitter using a time interval analyzer, bit error rate tester, or oscilloscope.
- High frequency and low frequency pattern generator—the high frequency patterns generate alternate ones and zeros and the low frequency patterns generate five ones and five zeroes. These patterns do not have a corresponding verifier.



The self-test features are only supported in Basic mode.

## BIST

Figure 1-73 shows the datapath for BIST incremental data pattern test mode. The BIST incremental data generator and verifier are located near the FPGA fabric in the PCS block of the transceiver channel.

Figure 1-73. BIST Incremental Pattern Test Mode Datapath

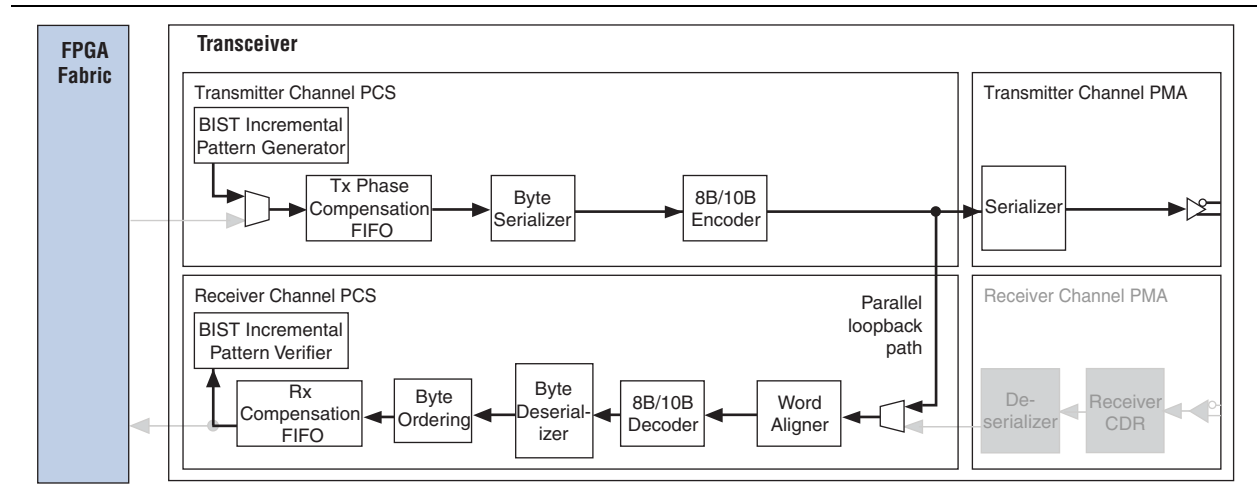

The incremental pattern generator and verifier are 16-bits wide. The generated pattern increments from 00 to FF and passes through the TX PCS blocks, parallel looped back to RX PCS blocks, and checked by the verifier. The pattern is also available as serial data at the `tx_dataout` port. The differential output voltage of the transmitted serial data on the `tx_dataout` port is based on the selected  $V_{OD}$  settings. The incremental data pattern is not available to the FPGA logic at the receiver for verification.

The following are the transceiver channel configuration settings in this mode:

- PCS-FPGA fabric channel width: 16-bit
- 8B/10B blocks: Enabled
- Byte serializer/deserializer: Enabled
- Word aligner: Automatic synchronization state machine mode
- Byte ordering: Enabled

The `rx_bisterr` and `rx_bistdone` signals indicate the status of the verifier. The `rx_bisterr` signal is asserted and stays high when detecting an error in the data. The `rx_bistdone` signal is asserted and stays high when the verifier either receives a full cycle of incremental pattern or it detects an error in the receiver data. You can reset the incremental pattern generator and verifier by asserting the `tx_digitalreset` and `rx_digitalreset` ports, respectively.

## PRBS

Figure 1-74 shows the datapath for the PRBS, high and low frequency pattern test modes. The pattern generator is located in TX PCS before the serializer, and PRBS pattern verifier located in RX PCS after the word aligner.

Figure 1-74. PRBS Pattern Test Mode Datapath

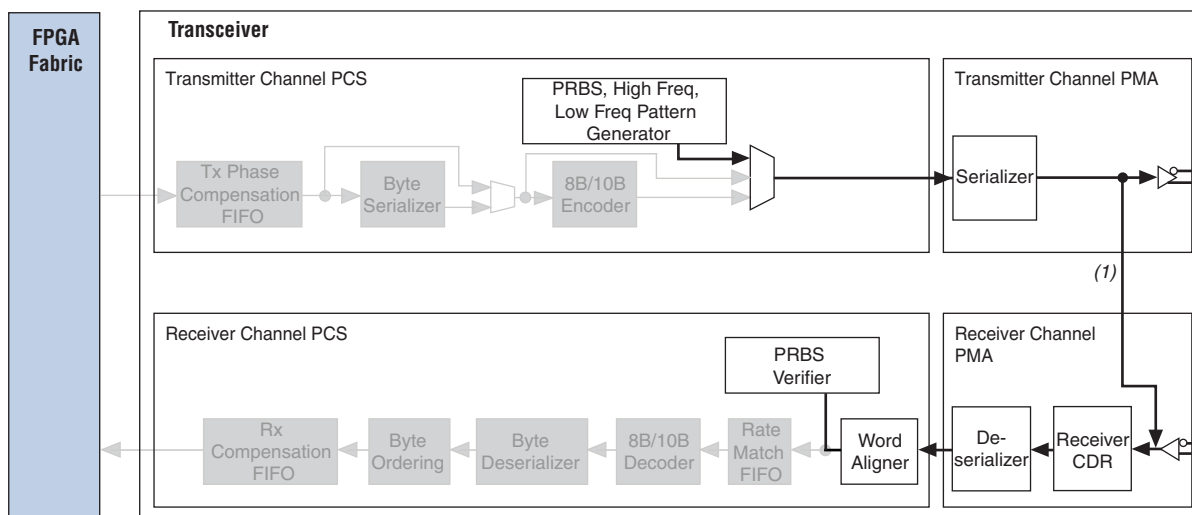

**Note to Figure 1-74:**

(1) Serial loopback path is optional and can be enabled for the PRBS verifier to check the PRBS pattern

Table 1-25 lists the supported PRBS, high and low frequency patterns, and corresponding channel settings. The PRBS pattern repeats after completing an iteration. The number of bits a PRBS X pattern sends before repeating the pattern is  $2^{(X-1)}$  bits.

Table 1-25. PRBS, High and Low Frequency Patterns, and Channel Settings (Part 1 of 2)

Patterns	Polynomial	8-bit Channel Width				10-bit Channel Width			
		Channel Width of 8 bits (1)	Word Alignment Pattern	Maximum Data Rate (Gbps) for F324 and Smaller Packages	Maximum Data Rate (Gbps) for F484 and Larger Packages	Channel Width of 10-bits (1)	Word Alignment Pattern	Maximum Data Rate (Gbps) for F324 and Smaller Packages	Maximum Data Rate (Gbps) for F484 and Larger Packages
PRBS 7	$X^7 + X^6 + 1$	Y	16'h3040	2.0	2.5	N	—	—	—
PRBS 8	$X^8 + X^7 + 1$	Y	16'hFF5A	2.0	2.5	N	—	—	—
PRBS 10	$X^{10} + X^7 + 1$	N	—	—	—	Y	10'h3FF	2.5	3.125
PRBS 23	$X^{23} + X^{18} + 1$	Y	16'hFFFF	2.0	2.5	N	—	—	—
High frequency (2)	1010101010	Y	—	2.0	2.5	Y	—	2.5	3.125

**Table 1–25. PRBS, High and Low Frequency Patterns, and Channel Settings (Part 2 of 2)**

Patterns	Polynomial	8-bit Channel Width				10-bit Channel Width			
		Channel Width of 8 bits (1)	Word Alignment Pattern	Maximum Data Rate (Gbps) for F324 and Smaller Packages	Maximum Data Rate (Gbps) for F484 and Larger Packages	Channel Width of 10-bits (1)	Word Alignment Pattern	Maximum Data Rate (Gbps) for F324 and Smaller Packages	Maximum Data Rate (Gbps) for F484 and Larger Packages
Low Frequency (2)	1111100000	N	—	—	—	Y	—	2.5	3.125

**Notes to Table 1–25:**

- (1) Channel width refers to the **What is the channel width?** option in the **General** screen of the ALTGX MegaWizard Plug-In Manager. Based on the selection, an 8 or 10 bits wide pattern is generated as indicated by a **Yes (Y)** or **No (N)**.
- (2) A verifier and associated `rx_bistdone` and `rx_bisterr` signals are not available for the specified patterns.

You can enable the serial loopback option to loop the generated PRBS patterns to the receiver channel for verifier to check the PRBS patterns. When the PRBS pattern is received, the `rx_bisterr` and `rx_bistdone` signals indicate the status of the verifier. After the word aligner restores the word boundary, the `rx_bistdone` signal is driven high when the verifier receives a complete pattern cycle and remains asserted until it is reset using the `rx_digitalreset` port. After the assertion of `rx_bistdone`, the `rx_bisterr` signal is asserted for a minimum of three `rx_clkout` cycles when errors are detected in the data and deasserts if the following PRBS sequence contains no error. You can reset the PRBS pattern generator and verifier by asserting the `tx_digitalreset` and `rx_digitalreset` ports, respectively.

## Transceiver Top-Level Port Lists

Table 1-26 through Table 1-29 provide descriptions of the ports available when instantiating a transceiver using the ALTGX megafunction. The ALTGX megafunction requires a relatively small number of signals. There are also a large number of optional signals that facilitate debugging by providing information about the state of the transceiver.

**Table 1–26. Transmitter Ports in ALTGX Megafunction for Cyclone IV GX**

Block	Port Name	Input/Output	Clock Domain	Description
TX PCS	tx_datain	Input	Synchronous to tx_clkout (non-bonded modes) or coreclkout (bonded modes)	Parallel data input from the FPGA fabric to the transmitter. <ul style="list-style-type: none"> <li>Bus width depends on channel width multiplied by number of channels per instance.</li> </ul>
	tx_clkout	Output	Clock signal	FPGA fabric-transmitter interface clock in non-bonded modes <ul style="list-style-type: none"> <li>Each channel has a tx_clkout signal that can be used to clock data (tx_datain) from the FPGA fabric into the transmitter.</li> </ul>
	tx_coreclk	Input	Clock signal	Optional write clock port for the TX phase compensation FIFO.
	tx_phase_comp_fifo_error	Output	Synchronous to tx_clkout (non-bonded modes) or coreclkout (bonded modes)	TX phase compensation FIFO full or empty indicator. <ul style="list-style-type: none"> <li>A high level indicates FIFO is either full or empty.</li> </ul>
	tx_ctrlnable	Input	Synchronous to tx_clkout (non-bonded modes) or coreclkout (bonded modes)	8B/10B encoder control or data identifier. This signal passes through the TX Phase Compensation FIFO. <ul style="list-style-type: none"> <li>A high level to encode data as a /Kx.y/ control code group.</li> <li>A low level to encode data as a /Dx.y/ data code group.</li> </ul>
	tx_forcedisp	Input	Synchronous to tx_clkout (non-bonded modes) or coreclkout (bonded modes)	8B/10B encoder forcing disparity control. This signal passes through the TX Phase Compensation FIFO. <ul style="list-style-type: none"> <li>A high level to force encoding to positive or negative disparity depending on the tx_dispvall signal level.</li> <li>A low level to allow default encoding according to the 8B/10B running disparity rules.</li> </ul>
	tx_dispvall	Input	Synchronous to tx_clkout (non-bonded modes) or coreclkout (bonded modes)	8B/10B encoder forcing disparity value. This signal passes through the TX Phase Compensation FIFO. <ul style="list-style-type: none"> <li>A high level to force encoding with a negative disparity code group when tx_forcedisp port is asserted high.</li> <li>A low level to force encoding with a positive disparity code group when tx_forcedisp port is asserted high.</li> </ul>
	tx_invpolarity	Input	Asynchronous signal. Minimum pulse width is two parallel clock cycles.	Transmitter polarity inversion control. <ul style="list-style-type: none"> <li>A high level to invert the polarity of every bit of the 8- or 10-bit input data to the serializer.</li> </ul>
	tx_bitslipboundaryselect	Input	Asynchronous signal.	Control the number of bits to slip before serializer. <ul style="list-style-type: none"> <li>Valid values from 0 to 9</li> </ul>
TX PMA	tx_dataout	Output	—	Transmitter serial data output signal.
	tx_forceelec_idle	Input	Asynchronous signal.	Force the transmitter buffer to PIPE electrical idle signal levels. For equivalent signal defined in PIPE 2.00 specification, refer to <a href="#">Table 1–15 on page 1–54</a> .

**Table 1-27. Receiver Ports in ALTGX Megafunction for Cyclone IV GX (Part 1 of 3)**

Block	Port Name	Input/Output	Clock Domain	Description
RX PCS	rx_syncstatus	Output	Synchronous to tx_clkout (non-bonded modes with rate match FIFO), rx_clkout (non-bonded modes without rate match FIFO), coreclkout (bonded modes), or rx_coreclk (when using the optional rx_coreclk input)	Word alignment synchronization status indicator. This signal passes through the RX Phase Compensation FIFO. <ul style="list-style-type: none"> <li>Not available in bit-slip mode</li> </ul>
	rx_patterndetect	Output	Synchronous to tx_clkout (non-bonded modes with rate match FIFO), rx_clkout (non-bonded modes without rate match FIFO), coreclkout (bonded modes), or rx_coreclk (when using the optional rx_coreclk input)	Indicates when the word alignment logic detects the alignment pattern in the current word boundary. This signal passes through the RX Phase Compensation FIFO.
	rx_bitslip	Input	Asynchronous signal. Minimum pulse width is two parallel clock cycles.	Bit-slip control for the word aligner configured in bit-slip mode. <ul style="list-style-type: none"> <li>At every rising edge, word aligner slips one bit into the received data stream, effectively shifting the word boundary by one bit.</li> </ul>
	rx_rlv	Output	Asynchronous signal. Driven for a minimum of two recovered clock cycles in configurations without byte serializer and a minimum of three recovered clock cycles in configurations with byte serializer.	Run-length violation indicator. <ul style="list-style-type: none"> <li>A high pulse indicates that the number of consecutive 1s or 0s in the received data stream exceeds the programmed run length violation threshold.</li> </ul>
	rx_invpolarity	Input	Asynchronous signal. Minimum pulse width is two parallel clock cycles.	Generic receiver polarity inversion control. <ul style="list-style-type: none"> <li>A high level to invert the polarity of every bit of the 8- or 10-bit data to the word aligner.</li> </ul>
	rx_enapatternalign	Input	Asynchronous signal.	Controls the word aligner operation configured in manual alignment mode.
	rx_rmifodatainserted	Output	Synchronous to tx_clkout (non-bonded modes) or coreclkout (bonded modes)	Rate match FIFO insertion status indicator. <ul style="list-style-type: none"> <li>A high level indicates the rate match pattern byte is inserted to compensate for the ppm difference in the reference clock frequencies between the upstream transmitter and the local receiver.</li> </ul>
	rx_rmifodatadeleted	Output	Synchronous to tx_clkout (non-bonded modes) or coreclkout (bonded modes)	Rate match FIFO deletion status indicator. <ul style="list-style-type: none"> <li>A high level indicates the rate match pattern byte is deleted to compensate for the ppm difference in the reference clock frequencies between the upstream transmitter and the local receiver.</li> </ul>

Table 1-27. Receiver Ports in ALTX Megafunction for Cyclone IV GX (Part 2 of 3)

Block	Port Name	Input/Output	Clock Domain	Description
RX PCS	rx_rmfifo full	Output	Synchronous to tx_clkout (non-bonded modes) or coreclkout (bonded modes)	Rate match FIFO full status indicator. <ul style="list-style-type: none"> <li>A high level indicates the rate match FIFO is full.</li> <li>Driven for a minimum of two serial clock cycles in configurations without a byte serializer and a minimum of three recovered clock cycles in configurations with a byte serializer.</li> </ul>
	rx_rmfifo empty	Output	Synchronous to tx_clkout (non-bonded modes) or coreclkout (bonded modes)	Rate match FIFO empty status indicator. <ul style="list-style-type: none"> <li>A high level indicates the rate match FIFO is empty.</li> <li>Driven for a minimum of two serial clock cycles in configurations without a byte serializer and a minimum of three recovered clock cycles in configurations with a byte serializer.</li> </ul>
	rx_ctrl detect	Output	Synchronous to tx_clkout (non-bonded modes) or coreclkout (bonded modes)	8B/10B decoder control or data identifier. <ul style="list-style-type: none"> <li>A high level indicates received code group is a /Kx.y/ control code group.</li> <li>A low level indicates received code group is a /Dx.y/ data code group.</li> </ul>
	rx_err detect	Output	Synchronous to tx_clkout (non-bonded modes) or coreclkout (bonded modes)	8B/10B code group violation or disparity error indicator. <ul style="list-style-type: none"> <li>A high level indicates that a code group violation or disparity error was detected on the associated received code group.</li> <li>Use with the rx_disperr signal to differentiate between a code group violation or a disparity error as follows: [rx_errdetect:rx_disperr] <ul style="list-style-type: none"> <li>2'b00—no error</li> <li>2'b10—code group violation</li> <li>2'b11—disparity error or both</li> </ul> </li> </ul>
	rx_disperr	Output	Synchronous to tx_clkout (non-bonded modes) or coreclkout (bonded modes)	8B/10B disparity error indicator. <ul style="list-style-type: none"> <li>A high level indicates that a disparity error was detected on the associated received code group.</li> </ul>
	rx_running disp	Output	Synchronous to tx_clkout (non-bonded modes) or coreclkout (bonded modes)	8B/10B current running disparity indicator. <ul style="list-style-type: none"> <li>A high level indicates a positive current running disparity at the end of the decoded byte</li> <li>A low level indicates a negative current running disparity at the end of the decoded byte</li> </ul>
	rx_enbyteord	Input	Asynchronous signal	Enable byte ordering control <ul style="list-style-type: none"> <li>A low-to-high transition triggers the byte ordering block to restart byte ordering operation.</li> </ul>
	rx_byteorder alignstatus	Output	Synchronous to tx_clkout (non-bonded modes) or coreclkout (bonded modes)	Byte ordering status indicator. <ul style="list-style-type: none"> <li>A high level indicates that the byte ordering block has detected the programmed byte ordering pattern in the least significant byte of the received data from the byte deserializer.</li> </ul>
	rx_dataout	Output	Synchronous to tx_clkout (non-bonded modes) or coreclkout (bonded modes)	Parallel data output from the receiver to the FPGA fabric. <ul style="list-style-type: none"> <li>Bus width depends on channel width multiplied by number of channels per instance.</li> </ul>

**Table 1-27. Receiver Ports in ALTGX Megafunction for Cyclone IV GX (Part 3 of 3)**

Block	Port Name	Input/Output	Clock Domain	Description
RX PCS	rx_coreclk	Output	Clock signal	Optional read clock port for the RX phase compensation FIFO.
	rx_phase_comp_fifo_error	Output	Synchronous to tx_clkout (non-bonded modes) or coreclkout (bonded modes)	RX phase compensation FIFO full or empty indicator. <ul style="list-style-type: none"> <li>■ A high level indicates FIFO is either full or empty.</li> </ul>
	rx_bitslipboundaryselectout	Output	Asynchronous signal.	Indicate the number of bits slipped in the word aligner configured in manual alignment mode. <ul style="list-style-type: none"> <li>■ Values range from 0 to 9.</li> </ul>
RX PMA	rx_datain	Input	N/A	Receiver serial data input port.
	rx_freqlocked	Output	Asynchronous signal	Receiver CDR lock state indicator <ul style="list-style-type: none"> <li>■ A high level indicates the CDR is in LTD state.</li> <li>■ A low level indicates the CDR is in LTR state.</li> </ul>
	rx_locktodata	Input	Asynchronous signal	Receiver CDR LTD state control signal <ul style="list-style-type: none"> <li>■ A high level forces the CDR to LTD state</li> <li>■ When deasserted, the receiver CDR lock state depends on the rx_locktorefclk signal level.</li> </ul>
	rx_locktorefclk	Input	Asynchronous signal	Receiver CDR LTR state control signal. <ul style="list-style-type: none"> <li>■ The rx_locktorefclk and rx_locktodata signals control whether the receiver CDR states as follows: [rx_locktodata:rx_locktorefclk]</li> <li>■ 2'b00—receiver CDR is in automatic lock mode</li> <li>■ 2b'01—receiver CDR is in manual lock mode (LTR state)</li> <li>■ 2b'1x—receiver CDR is in manual lock mode (LTD state)</li> </ul>
	rx_signaldetect	Output	Asynchronous signal	Signal threshold detect indicator. <ul style="list-style-type: none"> <li>■ Available in Basic mode when 8B/10B encoder/decoder is used, and in PIPE mode.</li> <li>■ A high level indicates that the signal present at the receiver input buffer is above the programmed signal detection threshold value.</li> </ul>
	rx_recovclkout	Output	Clock signal	CDR low-speed recovered clock <ul style="list-style-type: none"> <li>■ Only available in the GIGE mode for applications such as Synchronous Ethernet.</li> </ul>

**Table 1-28. PIPE Interface Ports in ALTGX Megafunction for Cyclone IV GX<sup>(1)</sup> (Part 1 of 2)**

Port Name	Input/Output	Clock Domain	Description
fixedclk	Input	Clock signal	125-MHz clock for receiver detect and offset cancellation only in PIPE mode.
tx_detectrxloop	Input	Asynchronous signal	Receiver detect or reverse parallel loopback control. <ul style="list-style-type: none"> <li>■ A high level in the P1 power state and <code>tx_forceelecidle</code> signal asserted begins the receiver detection operation to determine if there is a valid receiver downstream. This signal must be deasserted when the <code>pipephydonestatus</code> signal indicates receiver detect completion.</li> <li>■ A high level in the P0 power state with the <code>tx_forceelecidle</code> signal deasserted dynamically configures the channel to support reverse parallel loopback mode.</li> </ul>
tx_forcedisp compliance	Input	Asynchronous signal	Force the 8B/10B encoder to encode with negative running disparity. <ul style="list-style-type: none"> <li>■ Assert only when transmitting the first byte of the PIPE-compliance pattern to force the 8B/10B encoder with a negative running disparity.</li> </ul>
pipe8b10binvpolarity	Input	Asynchronous signal	Invert the polarity of every bit of the 10-bit input to the 8B/10B decoder
powerdn	Input	Asynchronous signal	PIPE power state control. <ul style="list-style-type: none"> <li>■ Signal is 2 bits wide and is encoded as follows: <ul style="list-style-type: none"> <li>■ 2'b00: P0 (Normal operation)</li> <li>■ 2'b01: P0s (Low recovery time latency, low power state)</li> <li>■ 2'b10: P1 (Longer recovery time latency, lower power state)</li> <li>■ 2'b11: P2 (Lowest power state)</li> </ul> </li> </ul>
pipedatavalid	Output	N/A	Valid data and control on the <code>rx_dataout</code> and <code>rx_ctrlldetect</code> ports indicator.
pipephydone status	Output	Asynchronous signal	PHY function completion indicator. <ul style="list-style-type: none"> <li>■ Asserted for one clock cycle to communicate completion of several PHY functions, such as power state transition and receiver detection.</li> </ul>
pipeelecidle	Output	Asynchronous signal	Electrical idle detected or inferred at the receiver indicator. <ul style="list-style-type: none"> <li>■ When electrical idle inference is used, this signal is driven high when it infers an electrical idle condition</li> <li>■ When electrical idle inference is not used, the <code>rx_signaldetect</code> signal is inverted and driven on this port.</li> </ul>

**Table 1-28. PIPE Interface Ports in ALTGX Megafunction for Cyclone IV GX<sup>(1)</sup> (Part 2 of 2)**

Port Name	Input/Output	Clock Domain	Description
pipestatus	Output	N/A	<p>PIPE receiver status port.</p> <ul style="list-style-type: none"> <li>■ Signal is 3 bits wide and is encoded as follows: <ul style="list-style-type: none"> <li>■ 3'b000: Received data OK</li> <li>■ 3'b001: one SKP symbol added</li> <li>■ 3'b010: one SKP symbol removed</li> <li>■ 3'b011: Receiver detected</li> <li>■ 3'b100: 8B/10B decoder error</li> <li>■ 3'b101: Elastic buffer overflow</li> <li>■ 3'b110: Elastic buffer underflow</li> <li>■ 3'b111: Received disparity error</li> </ul> </li> </ul>
rx_elecidleinfersel	Input	N/A	Controls the electrical idle inference mechanism as specified in <a href="#">Table 1-17 on page 1-57</a>

**Note to Table 1-28:**

(1) For equivalent signals defined in PIPE 2.00 specification, refer to [Table 1-15 on page 1-54](#).

**Table 1-29. Multipurpose PLL, General Purpose PLL and Miscellaneous Ports in ALTGX Megafunction for Cyclone IV GX (Part 1 of 2)**

Block	Port Name	Input/Output	Clock Domain	Description
PLL	pll_inclk	Input	Clock signal	<p>Input reference clock for the PLL (multipurpose PLL or general purpose PLL) used by the transceiver instance. When configured with the transmitter and receiver channel configuration in Deterministic Latency mode, multiple <code>pll_inclk</code> ports are available as follows.</p> <p>Configured with PLL PFD feedback—<i>x</i> is the number of channels selected:</p> <ul style="list-style-type: none"> <li>■ <code>pll_inclk[x-1..0]</code> are input reference clocks for each transmitter in the transceiver instance</li> <li>■ <code>pll_inclk[x+1..x]</code> are input reference clocks for receivers in the transceiver instance</li> </ul> <p>Configured without PLL PFD feedback:</p> <ul style="list-style-type: none"> <li>■ <code>pll_inclk[0]</code> is input reference clock for transmitters in the transceiver instance</li> <li>■ <code>pll_inclk[1]</code> is input reference clock for receivers in the transceiver instance</li> </ul>
	pll_locked	Output	Asynchronous signal	PLL (used by the transceiver instance) lock indicator.
	pll_areset	Input	Asynchronous signal	<p>PLL (used by the transceiver instance) reset.</p> <ul style="list-style-type: none"> <li>■ When asserted, the PLL is kept in reset state.</li> <li>■ When deasserted, the PLL is active and locks to the input reference clock.</li> </ul>
	coreclkout	Output	Clock signal	FPGA fabric-transceiver interface clock in bonded modes.

**Table 1–29. Multipurpose PLL, General Purpose PLL and Miscellaneous Ports in ALTGX Megafunction for Cyclone IV GX (Part 2 of 2)**

Block	Port Name	Input/Output	Clock Domain	Description
Reset & Power Down	gxb_powerdown	Input	Asynchronous signal	Transceiver block power down. <ul style="list-style-type: none"> <li>When asserted, all digital and analog circuitry in the PCS, HSSI, CDR, and PCIe modules are powered down.</li> <li>Asserting the <code>gxb_powerdown</code> signal does not power down the <code>refclk</code> buffers.</li> </ul>
	tx_digitalreset	Input	Asynchronous signal. The minimum pulse width is two parallel clock cycles.	Transmitter PCS reset. <ul style="list-style-type: none"> <li>When asserted, the transmitter PCS blocks are reset.</li> </ul>
	rx_analogreset	Input	Asynchronous signal. The minimum pulse width is two parallel clock cycles.	Receiver PMA reset. <ul style="list-style-type: none"> <li>When asserted, analog circuitry in the receiver PMA block is reset.</li> </ul>
	rx_digitalreset	Input	Asynchronous signal. The minimum pulse width is two parallel clock cycles.	Receiver PCS reset. <ul style="list-style-type: none"> <li>When asserted, the receiver PCS blocks are reset.</li> </ul>
Reconfiguration	reconfig_clk	Input	Clock signal	Dynamic reconfiguration clock. <ul style="list-style-type: none"> <li>Also used for offset cancellation except in PIPE mode.</li> <li>For the supported frequency range for this clock, refer to the <i>Cyclone IV Device Data Sheet</i> chapter.</li> </ul>
	reconfig_togxb	Input	Asynchronous signal	From the dynamic reconfiguration controller.
	reconfig_fromgxb	Output	Asynchronous signal	To the dynamic reconfiguration controller.
Calibration Block	cal_blk_clk	Input	Clock signal	Clock for the transceiver calibration block.
	cal_blk_powerdown	Input	Asynchronous signal	Calibration block power down control.
Test Mode	rx_bistdone	Output	Asynchronous signal	BIST or PRBS test completion indicator. <ul style="list-style-type: none"> <li>A high level during BIST test mode indicates the verifier either receives complete pattern cycle or detects an error and stays asserted until being reset using the <code>rx_digitalreset</code> port.</li> <li>A high level during PRBS test mode indicates the verifier receives complete pattern cycle and stays asserted until being reset using the <code>rx_digitalreset</code> port.</li> </ul>
	rx_bisterr	Output	Asynchronous signal	BIST or PRBS verifier error indicator <ul style="list-style-type: none"> <li>In BIST test mode, the signal stays asserted upon detecting an error until being reset using the <code>rx_digitalreset</code> port.</li> <li>In PRBS test mode, the signal asserts for a minimum of 3 <code>rx_clkout</code> clock cycles upon detecting an error and deasserts if the following PRBS sequence contains no error.</li> </ul>

## Document Revision History

Table 1-30 lists the revision history for this chapter.

**Table 1-30. Document Revision History**

Date	Version	Changes
February 2015	3.7	<ul style="list-style-type: none"> <li>■ Updated the GiGE row in Table 1-14.</li> <li>■ Updated the “GIGE Mode” section.</li> <li>■ Updated the note in the “Clock Frequency Compensation” section.</li> </ul>
October 2013	3.6	Updated Figure 1-15 and Table 1-4.
May 2013	3.5	Updated Table 1-27 by setting “rx_locktodata” and “rx_locktorefclk” to “Input”
October 2012	3.4	<ul style="list-style-type: none"> <li>■ Updated the data rate for the V-by-one protocol and the F324 package support in HD-SDI in Table 1-1.</li> <li>■ Updated note (1) to Figure 1-27.</li> <li>■ Added latency information to Figure 1-67.</li> </ul>
November 2011	3.3	<ul style="list-style-type: none"> <li>■ Updated “Word Aligner” and “Basic Mode” sections.</li> <li>■ Updated Figure 1-37.</li> </ul>
December 2010	3.2	<ul style="list-style-type: none"> <li>■ Updated for the Quartus II software version 10.1 release.</li> <li>■ Updated Table 1-1, Table 1-5, Table 1-11, Table 1-14, Table 1-24, Table 1-25, Table 1-26, Table 1-27, Table 1-28, and Table 1-29.</li> <li>■ Updated “8B/10B Encoder”, “Transmitter Output Buffer”, “Receiver Input Buffer”, “Clock Data Recovery”, “Miscellaneous Transmitter PCS Features”, “Miscellaneous Receiver PCS Feature”, “Input Reference Clocking”, “PCI Express (PIPE) Mode”, “Channel Deskewing”, “Lane Synchronization”, “Serial Loopback”, and “Self Test Modes” sections.</li> <li>■ Added Figure 1-9, Figure 1-10, Figure 1-19, Figure 1-20, and Figure 1-43.</li> <li>■ Updated Figure 1-53, Figure 1-55, Figure 1-59, Figure 1-60, Figure 1-69, Figure 1-70, Figure 1-71, Figure 1-72, Figure 1-73, and Figure 1-74.</li> </ul>
November 2010	3.1	Updated Introductory information.
July 2010	3.0	<ul style="list-style-type: none"> <li>■ Updated information for the Quartus II software version 10.0 release.</li> <li>■ Reset control, power down, and dynamic reconfiguration information moved to new <i>Cyclone IV Reset Control and Power Down</i> and <i>Cyclone IV Dynamic Reconfiguration</i> chapters.</li> </ul>



Cyclone® IV GX devices offer multiple reset signals to control transceiver channels independently. The ALTGX Transceiver MegaWizard™ Plug-In Manager provides individual reset signals for each channel instantiated in your design. It also provides one power-down signal for each transceiver block.

This chapter includes the following sections:

- “User Reset and Power-Down Signals” on page 2–2
- “Transceiver Reset Sequences” on page 2–4
- “Dynamic Reconfiguration Reset Sequences” on page 2–19
- “Power Down” on page 2–21
- “Simulation Requirements” on page 2–22
- “Reference Information” on page 2–23

Figure 2–1 shows the reset control and power-down block for a Cyclone IV GX device.

**Figure 2–1. Reset Control and Power-Down Block**

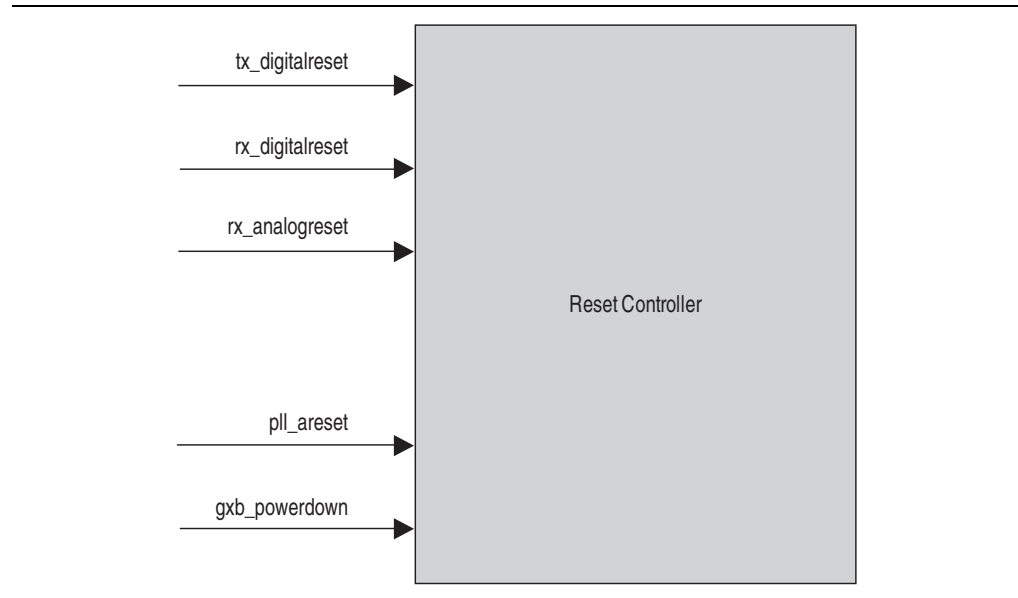

## User Reset and Power-Down Signals

Each transceiver channel in the Cyclone IV GX device has individual reset signals to reset its physical coding sublayer (PCS) and physical medium attachment (PMA). The transceiver block also has a power-down signal that affects the multipurpose phase-locked loops (PLLs), general purpose PLLs, and all the channels in the transceiver block.



All reset and power-down signals are asynchronous.

Table 2-1 lists the reset signals available for each transceiver channel.

**Table 2-1. Transceiver Channel Reset Signals**

Signal	ALTGX MegaWizard Plug-In Manager Configurations	Description
<code>tx_digitalreset</code> <sup>(1)</sup>	<ul style="list-style-type: none"> <li>■ Transmitter Only</li> <li>■ Receiver and Transmitter</li> </ul>	<p>Provides asynchronous reset to all digital logic in the transmitter PCS, including the XAUI transmit state machine.</p> <p>The minimum pulse width for this signal is two parallel clock cycles.</p>
<code>rx_digitalreset</code> <sup>(1)</sup>	<ul style="list-style-type: none"> <li>■ Receiver Only</li> <li>■ Receiver and Transmitter</li> </ul>	<p>Resets all digital logic in the receiver PCS, including:</p> <ul style="list-style-type: none"> <li>■ XAUI receiver state machines</li> <li>■ GIGE receiver state machines</li> <li>■ XAUI channel alignment state machine</li> <li>■ BIST-PRBS verifier</li> <li>■ BIST-incremental verifier</li> </ul> <p>The minimum pulse width for this signal is two parallel clock cycles.</p>
<code>rx_analogreset</code>	<ul style="list-style-type: none"> <li>■ Receiver Only</li> <li>■ Receiver and Transmitter</li> </ul>	<p>Resets the receiver CDR present in the receiver channel.</p> <p>The minimum pulse width is two parallel clock cycles.</p>

**Note to Table 2-1:**

- (1) Assert this signal until the clocks coming out of the multipurpose PLL and receiver CDR are stabilized. Stable parallel clocks are essential for proper operation of transmitter and receiver phase-compensation FIFOs in the PCS.

Table 2–2 lists the power-down signals available for each transceiver block.

**Table 2–2. Transceiver Block Power-Down Signals**

Signal	Description
pll_areset	Resets the transceiver PLL. The <code>pll_areset</code> signal is asserted in two conditions: <ul style="list-style-type: none"> <li>■ During reset sequence, the signal is asserted to reset the transceiver PLL. This signal is controlled by the user.</li> <li>■ After the transceiver PLL is reconfigured, the signal is asserted high by the <code>ALTPLL_RECONFIG</code> controller. This signal is not controlled by the user.</li> </ul>
gxb_powerdown	Powers down the entire transceiver block. When this signal is asserted, this signal powers down the PCS and PMA in all the transceiver channels. This signal operates independently from the other reset signals. This signal is common to the transceiver block.
pll_locked	A status signal. Indicates the status of the transmitter multipurpose PLLs or general purpose PLLs. <ul style="list-style-type: none"> <li>■ A high level—indicates the multipurpose PLL or general purpose PLL is locked to the incoming reference clock frequency.</li> </ul>
rx_freqlocked	A status signal. Indicates the status of the receiver CDR lock mode. <ul style="list-style-type: none"> <li>■ A high level—the receiver is in lock-to-data mode.</li> <li>■ A low level—the receiver CDR is in lock-to-reference mode.</li> </ul>
busy	A status signal. An output from the <code>ALTGX_RECONFIG</code> block indicates the status of the dynamic reconfiguration controller. This signal remains low for the first <code>reconfig_clk</code> clock cycle after power up. It then gets asserted from the second <code>reconfig_clk</code> clock cycle. Assertion on this signal indicates that the offset cancellation process is being executed on the receiver buffer as well as the receiver CDR. When this signal is deasserted, it indicates that offset cancellation is complete.  This busy signal is also used to indicate the dynamic reconfiguration duration such as in analog reconfiguration mode and channel reconfiguration mode.

 For more information about offset cancellation, refer to the *Cyclone IV Dynamic Reconfiguration* chapter.

 If none of the channels is instantiated in a transceiver block, the Quartus® II software automatically powers down the entire transceiver block.

## Blocks Affected by the Reset and Power-Down Signals

Table 2–3 lists the blocks that are affected by specific reset and power-down signals.

**Table 2–3. Blocks Affected by Reset and Power-Down Signals (Part 1 of 2)**

Transceiver Block	rx_digitalreset	rx_analogreset	tx_digitalreset	pll_areset	gxb_powerdown
multipurpose PLLs and general purpose PLLs	—	—	—	✓	—
Transmitter Phase Compensation FIFO	—	—	✓	—	✓
Byte Serializer	—	—	✓	—	✓
8B/10B Encoder	—	—	✓	—	✓

**Table 2-3. Blocks Affected by Reset and Power-Down Signals (Part 2 of 2)**

Transceiver Block	rx_digitalreset	rx_analogreset	tx_digitalreset	pll_aret	gxb_powerdown
Serializer	—	—	✓	—	✓
Transmitter Buffer	—	—	—	—	✓
Transmitter XAUI State Machine	—	—	✓	—	✓
Receiver Buffer	—	—	—	—	✓
Receiver CDR	—	✓	—	—	✓
Receiver Deserializer	—	—	—	—	✓
Receiver Word Aligner	✓	—	—	—	✓
Receiver Deskew FIFO	✓	—	—	—	✓
Receiver Clock Rate Compensation FIFO	✓	—	—	—	✓
Receiver 8B/10B Decoder	✓	—	—	—	✓
Receiver Byte Deserializer	✓	—	—	—	✓
Receiver Byte Ordering	✓	—	—	—	✓
Receiver Phase Compensation FIFO	✓	—	—	—	✓
Receiver XAUI State Machine	✓	—	—	—	✓
BIST Verifiers	✓	—	—	—	✓

## Transceiver Reset Sequences

You can configure transceiver channels in Cyclone IV GX devices in various configurations. In all functional modes except XAUI functional mode, transceiver channels can be either bonded or non-bonded. In XAUI functional mode, transceiver channels must be bonded. In PCI Express® (PCIe®) functional mode, transceiver channels can be either bonded or non-bonded and need to follow a specific reset sequence.

The two categories of reset sequences for Cyclone IV GX devices described in this chapter are:

- **“All Supported Functional Modes Except the PCIe Functional Mode” on page 2-6**—describes the reset sequences in bonded and non-bonded configurations.
- **“PCIe Functional Mode” on page 2-17**—describes the reset sequence for the initialization/compliance phase and the normal operation phase in PCIe functional modes.

 The busy signal remains low for the first `reconfig_clk` clock cycle. It then gets asserted from the second `reconfig_clk` clock cycle. Subsequent deassertion of the busy signal indicates the completion of the offset cancellation process. This busy signal is required in transceiver reset sequences except for transmitter only channel configurations. Refer to the reset sequences shown in [Figure 2-2](#) and the associated references listed in the notes for the figure.

 Altera strongly recommends adhering to these reset sequences for proper operation of the Cyclone IV GX transceiver.

[Figure 2-2](#) shows the transceiver reset sequences for Cyclone IV GX devices.

**Figure 2-2. Transceiver Reset Sequences Chart**

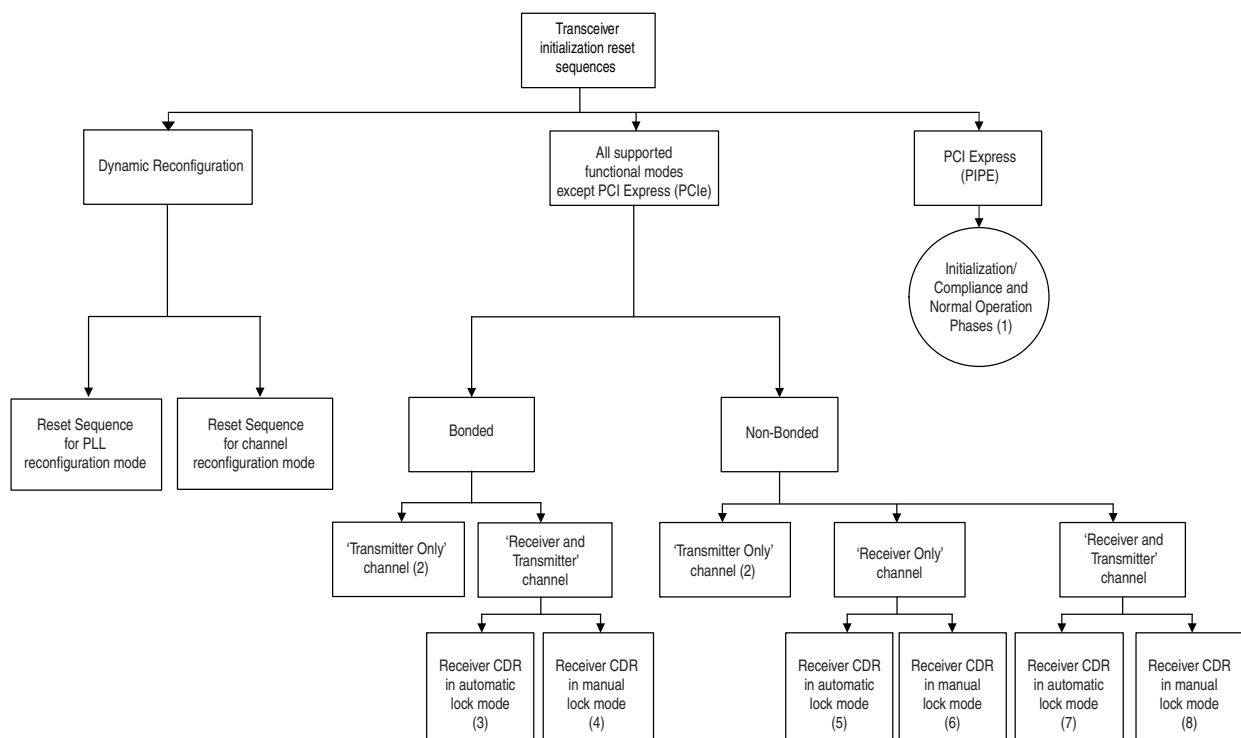

**Notes to Figure 2-2:**

- (1) Refer to the Timing Diagram in [Figure 2-10](#).
- (2) Refer to the Timing Diagram in [Figure 2-3](#).
- (3) Refer to the Timing Diagram in [Figure 2-4](#).
- (4) Refer to the Timing Diagram in [Figure 2-5](#).
- (5) Refer to the Timing Diagram in [Figure 2-6](#).
- (6) Refer to the Timing Diagram in [Figure 2-7](#).
- (7) Refer to the Timing Diagram in [Figure 2-8](#).
- (8) Refer to the Timing Diagram in [Figure 2-9](#).

## All Supported Functional Modes Except the PCIe Functional Mode

This section describes reset sequences for transceiver channels in bonded and non-bonded configurations. Timing diagrams of some typical configurations are shown to facilitate proper reset sequence implementation. In these functional modes, you can set the receiver CDR either in automatic lock or manual lock mode.



In manual lock mode, the receiver CDR locks to the reference clock (lock-to-reference) or the incoming serial data (lock-to-data), depending on the logic levels on the `rx_locktorefclk` and `rx_locktodata` signals. With the receiver CDR in manual lock mode, you can either configure the transceiver channels in the Cyclone IV GX device in a non-bonded configuration or a bonded configuration. In a bonded configuration, for example in XAUI mode, four channels are bonded together.

Table 2-4 lists the lock-to-reference (LTR) and lock-to-data (LTD) controller lock modes for the `rx_locktorefclk` and `rx_locktodata` signals.

**Table 2-4. Lock-To-Reference and Lock-To-Data Modes**

<code>rx_locktorefclk</code>	<code>rx_locktodata</code>	LTR/LTD Controller Lock Mode
1	0	Manual, LTR Mode
—	1	Manual, LTD Mode
0	0	Automatic Lock Mode

### Bonded Channel Configuration

In a bonded channel configuration, you can reset all the bonded channels simultaneously. Examples of bonded channel configurations are the XAUI, PCIe Gen1  $\times 2$  and  $\times 4$ , and Basic  $\times 2$  and  $\times 4$  functional modes. In Basic  $\times 2$  and  $\times 4$  functional mode, you can bond **Transmitter Only** channels together.

In XAUI mode, the receiver and transmitter channels are bonded. Each of the receiver channels in this mode has its own `rx_freqlocked` output status signals. You must consider the timing of these signals in the reset sequence.

Table 2-5 lists the reset and power-down sequences for bonded configurations under the stated functional modes.

**Table 2-5. Reset and Power-Down Sequences for Bonded Channel Configurations**

Channel Set Up	Receiver CDR Mode	Refer to
Transmitter Only	Basic $\times 2$ and $\times 4$	“Transmitter Only Channel” on page 2-7
Receiver and Transmitter	Automatic lock mode for XAUI functional mode	“Receiver and Transmitter Channel—Receiver CDR in Automatic Lock Mode” on page 2-8
Receiver and Transmitter	Manual lock mode for XAUI functional mode	“Receiver and Transmitter Channel—Receiver CDR in Manual Lock Mode” on page 2-9

### Transmitter Only Channel

This configuration contains only a transmitter channel. If you create a **Transmitter Only** instance in the ALTGX MegaWizard Plug-In Manager in Basic  $\times 4$  functional mode, use the reset sequence shown in [Figure 2-3](#).

**Figure 2-3. Sample Reset Sequence for Bonded and Non-Bonded Configuration Transmitter Only Channels**

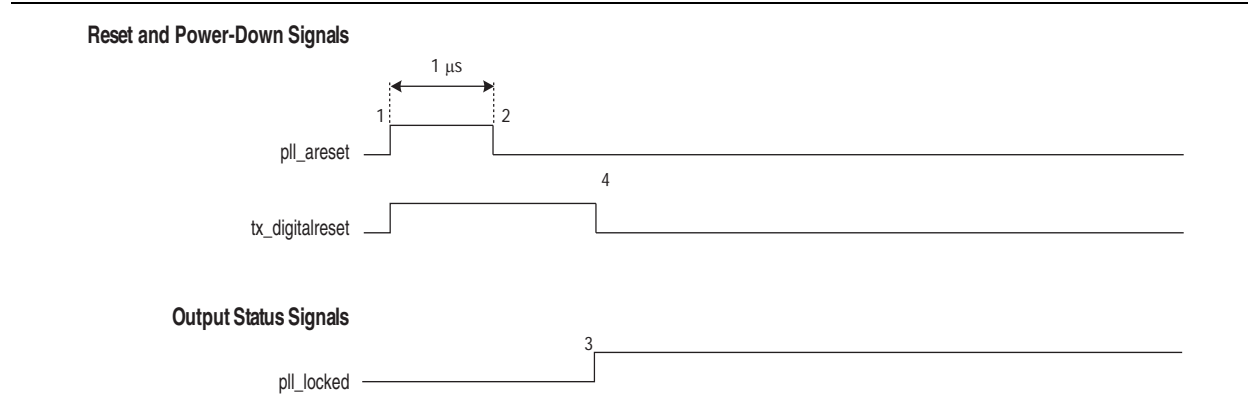

As shown in [Figure 2-3](#), perform the following reset procedure for the **Transmitter Only** channel configuration:

1. After power up, assert `pll_areset` for a minimum period of 1  $\mu\text{s}$  (the time between markers 1 and 2).
2. Keep the `tx_digitalreset` signal asserted during this time period. After you de-assert the `pll_areset` signal, the multipurpose PLL starts locking to the transmitter input reference clock.
3. When the multipurpose PLL locks, as indicated by the `pll_locked` signal going high (marker 3), de-assert the `tx_digitalreset` signal (marker 4). At this point, the transmitter is ready for transmitting data.

**Receiver and Transmitter Channel—Receiver CDR in Automatic Lock Mode**

This configuration contains both a transmitter and receiver channel. When the receiver CDR is in automatic lock mode, use the reset sequence shown in Figure 2-4.

**Figure 2-4. Sample Reset Sequence for Bonded Configuration Receiver and Transmitter Channels—Receiver CDR in Automatic Lock Mode**

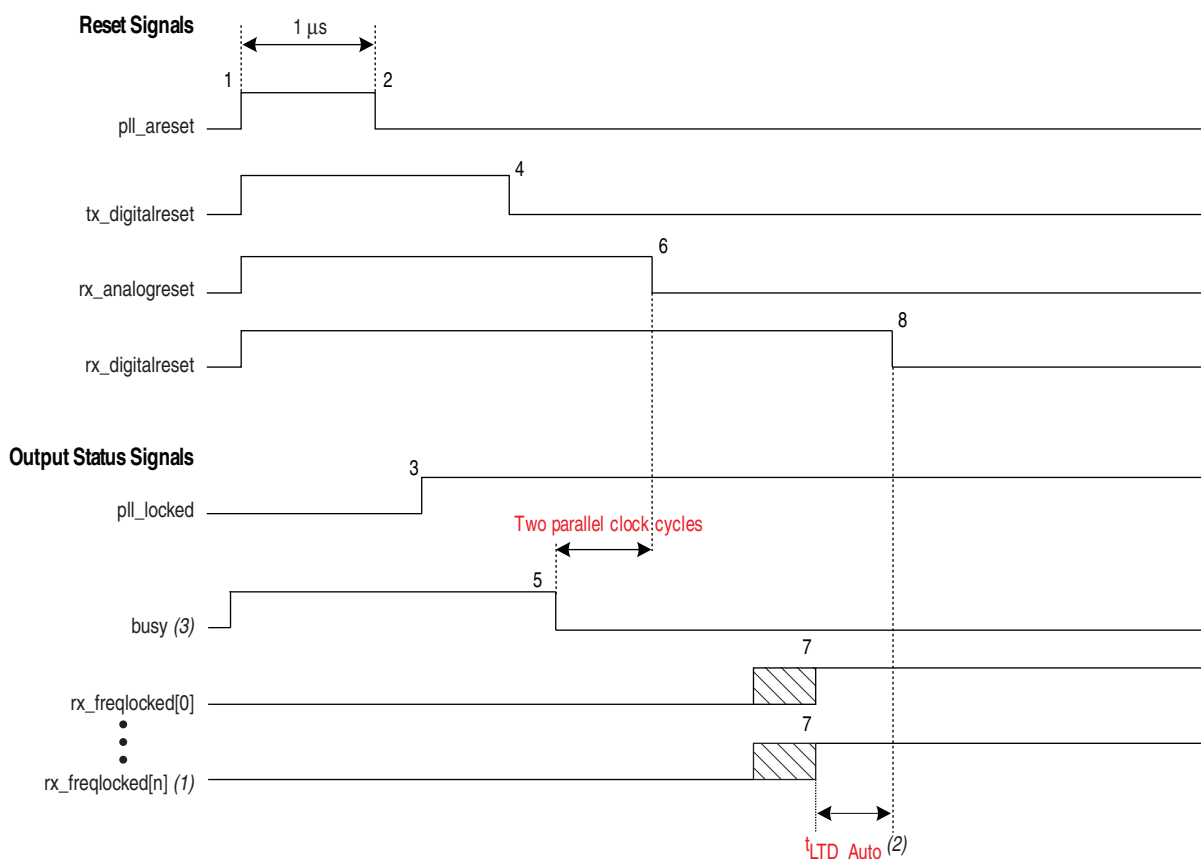
**Notes to Figure 2-4:**

- (1) The number of `rx_freqlocked[n]` signals depend on the number of channels configured. `n`=number of channels.
- (2) For  $t_{LTD\_Auto}$  duration, refer to the *Cyclone IV Device Datasheet* chapter.
- (3) The `busy` signal is asserted and deasserted only during initial power up when offset cancellation occurs. In subsequent reset sequences, the `busy` signal is asserted and deasserted only if there is a read or write operation to the `ALTGX_RECONFIG` megafunction.

As shown in Figure 2-4, perform the following reset procedure for the receiver CDR in automatic lock mode configuration:

1. After power up, assert `pll_areset` for a minimum period of 1  $\mu$ s (the time between markers 1 and 2).
2. Keep the `tx_digitalreset`, `rx_analogreset`, and `rx_digitalreset` signals asserted during this time period. After you deassert the `pll_areset` signal, the multipurpose PLL starts locking to the input reference clock.
3. After the multipurpose PLL locks, as indicated by the `pll_locked` signal going high, deassert the `tx_digitalreset` signal. At this point, the transmitter is ready for data traffic.

4. For the receiver operation, after deassertion of busy signal, wait for two parallel clock cycles to deassert the rx\_analogreset signal.
5. Wait for the rx\_freqlocked signal from each channel to go high. The rx\_freqlocked signal of each channel may go high at different times (indicated by the slashed pattern at marker 7).
6. In a bonded channel group, when the rx\_freqlocked signals of all the channels has gone high, from that point onwards, wait for at least  $t_{LTD\_Auto}$  time for the receiver parallel clock to be stable, then deassert the rx\_digitalreset signal (marker 8). At this point, all the receivers are ready for data traffic.

### Receiver and Transmitter Channel—Receiver CDR in Manual Lock Mode

This configuration contains both a transmitter and receiver channel. When the receiver CDR is in manual lock mode, use the reset sequence shown in Figure 2-5.

**Figure 2-5. Sample Reset Sequence for Bonded Configuration Receiver and Transmitter Channels—Receiver CDR in Manual Lock Mode**

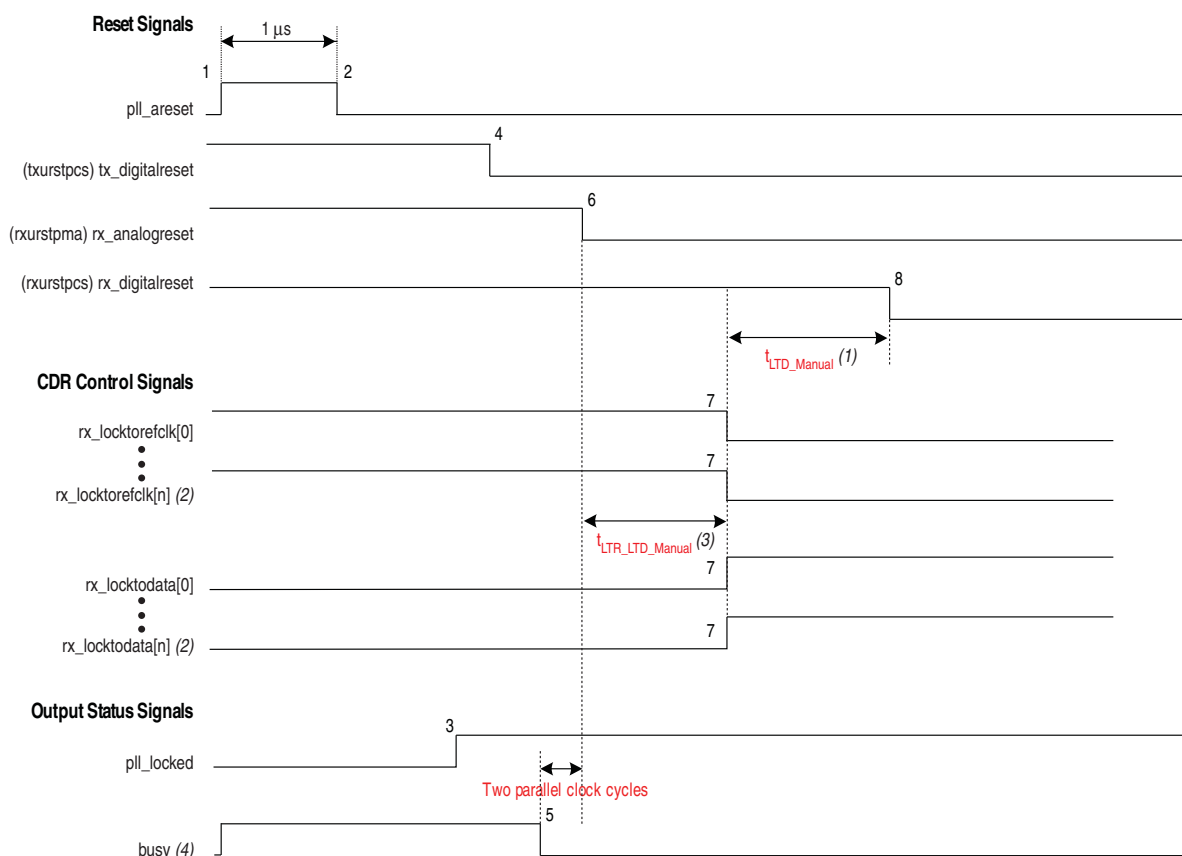

**Notes to Figure 2-5:**

- (1) For  $t_{LTD\_Manual}$  duration, refer to the *Cyclone IV Device Datasheet* chapter.
- (2) The number of `rx_locktofreqclk[n]` and `rx_locktodata[n]` signals depend on the number of channels configured. n=number of channels.
- (3) For  $t_{LTR\_LTD\_Manual}$  duration, refer to the *Cyclone IV Device Datasheet* chapter.
- (4) The `busy` signal is asserted and deasserted only during initial power up when offset cancellation occurs. In subsequent reset sequences, the `busy` signal is asserted and deasserted only if there is a read or write operation to the `ALTGX_RECONFIG` megafunction.

As shown in [Figure 2-5](#), perform the following reset procedure for the receiver CDR in manual lock mode configuration:

1. After power up, assert `p11_areset` for a minimum period of 1  $\mu$ s (the time between markers 1 and 2).
2. Keep the `tx_digitalreset`, `rx_analogreset`, `rx_digitalreset`, and `rx_locktorefc1k` signals asserted and the `rx_locktodata` signal deasserted during this time period. After you deassert the `p11_areset` signal, the multipurpose PLL starts locking to the input reference clock.
3. After the multipurpose PLL locks, as indicated by the `p11_locked` signal going high (marker 3), deassert the `tx_digitalreset` signal (marker 4). For the receiver operation, after deassertion of the busy signal, wait for **two parallel clock cycles** to deassert the `rx_analogreset` signal.
4. In a bonded channel group, wait for at least  $t_{LTR\_LTD\_Manual}$ , then deassert `rx_locktorefc1k` and assert `rx_locktodata` (marker 7). At this point, the receiver CDR of all the channels enters into lock-to-data mode and starts locking to the received data.
5. After asserting the `rx_locktodata` signal, wait for at least  $t_{LTD\_Manual}$  before deasserting `rx_digitalreset` (the time between markers 7 and 8). At this point, the transmitter and receiver are ready for data traffic.

### Non-Bonded Channel Configuration

In non-bonded channels, each channel in the ALTGX MegaWizard Plug-In Manager instance contains its own `tx_digitalreset`, `rx_analogreset`, `rx_digitalreset`, and `rx_freqlocked` signals.

You can reset each channel independently. For example, if there are four non-bonded channels, the ALTGX MegaWizard Plug-In Manager provides four each of the following signals: `tx_digitalreset`, `rx_analogreset`, `rx_digitalreset`, and `rx_freqlocked`.

[Table 2-6](#) lists the reset and power-down sequences for one channel in a non-bonded configuration under the stated functional modes.

**Table 2-6. Reset and Power-Down Sequences for Non-Bonded Channel Configurations**

Channel Set Up	Receiver CDR Mode	Refer to
Transmitter Only	Basic $\times 1$	<a href="#">“Transmitter Only Channel” on page 2-11</a>
Receiver Only	Automatic lock mode	<a href="#">“Receiver Only Channel—Receiver CDR in Automatic Lock Mode” on page 2-11</a>
Receiver Only	Manual lock mode	<a href="#">“Receiver Only Channel—Receiver CDR in Manual Lock Mode” on page 2-12</a>
Receiver and Transmitter	Automatic lock mode	<a href="#">“Receiver and Transmitter Channel—Receiver CDR in Automatic Lock Mode” on page 2-13</a>
Receiver and Transmitter	Manual lock mode	<a href="#">“Receiver and Transmitter Channel—Receiver CDR in Manual Lock Mode” on page 2-14</a>



Follow the same reset sequence for all the other channels in the non-bonded configuration.

### Transmitter Only Channel

This configuration contains only a transmitter channel. If you create a **Transmitter Only** instance in the ALTGX MegaWizard Plug-In Manager, use the same reset sequence shown in [Figure 2-3 on page 2-7](#).

### Receiver Only Channel—Receiver CDR in Automatic Lock Mode

This configuration contains only a receiver channel. If you create a **Receiver Only** instance in the ALTGX MegaWizard Plug-In Manager with the receiver CDR in automatic lock mode, use the reset sequence shown in [Figure 2-6](#).

**Figure 2-6. Sample Reset Sequence of Receiver Only Channel—Receiver CDR in Automatic Lock Mode**

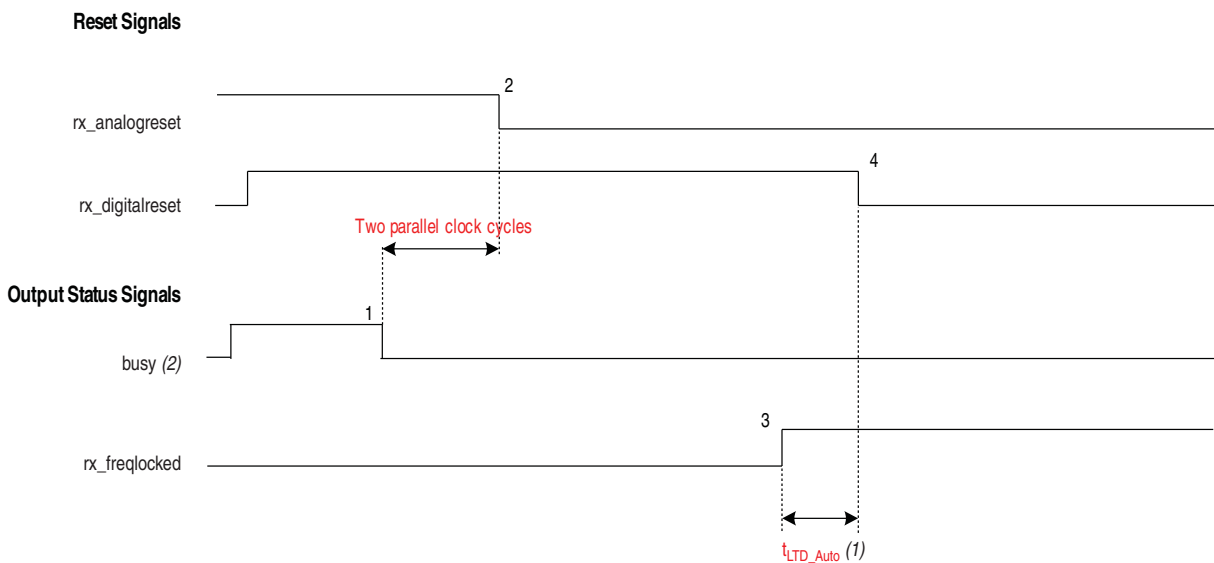

**Notes to Figure 2-6:**

- (1) For  $t_{LTD\_Auto}$  duration, refer to the [Cyclone IV Device Datasheet](#) chapter.
- (2) The `busy` signal is asserted and deasserted only during initial power up when offset cancellation occurs. In subsequent reset sequences, the `busy` signal is asserted and deasserted only if there is a read or write operation to the ALTGX\_RECONFIG megafunction.

As shown in [Figure 2-6](#), perform the following reset procedure for the receiver in CDR automatic lock mode:

1. After power up, wait for the `busy` signal to be deasserted.
2. Keep the `rx_digitalreset` and `rx_analogreset` signals asserted during this time period.
3. After the `busy` signal is deasserted, wait for another two parallel clock cycles, then deassert the `rx_analogreset` signal.
4. Wait for the `rx_freqlocked` signal to go high.
5. When `rx_freqlocked` goes high (marker 3), from that point onwards, wait for at least  $t_{LTD\_Auto}$ , then de-assert the `rx_digitalreset` signal (marker 4). At this point, the receiver is ready to receive data.

### Receiver Only Channel—Receiver CDR in Manual Lock Mode

This configuration contains only a receiver channel. If you create a **Receiver Only** instance in the ALTGX MegaWizard Plug-In Manager with receiver CDR in manual lock mode, use the reset sequence shown in [Figure 2-7](#).

**Figure 2-7. Sample Reset Sequence of Receiver Only Channel—Receiver CDR in Manual Lock Mode**

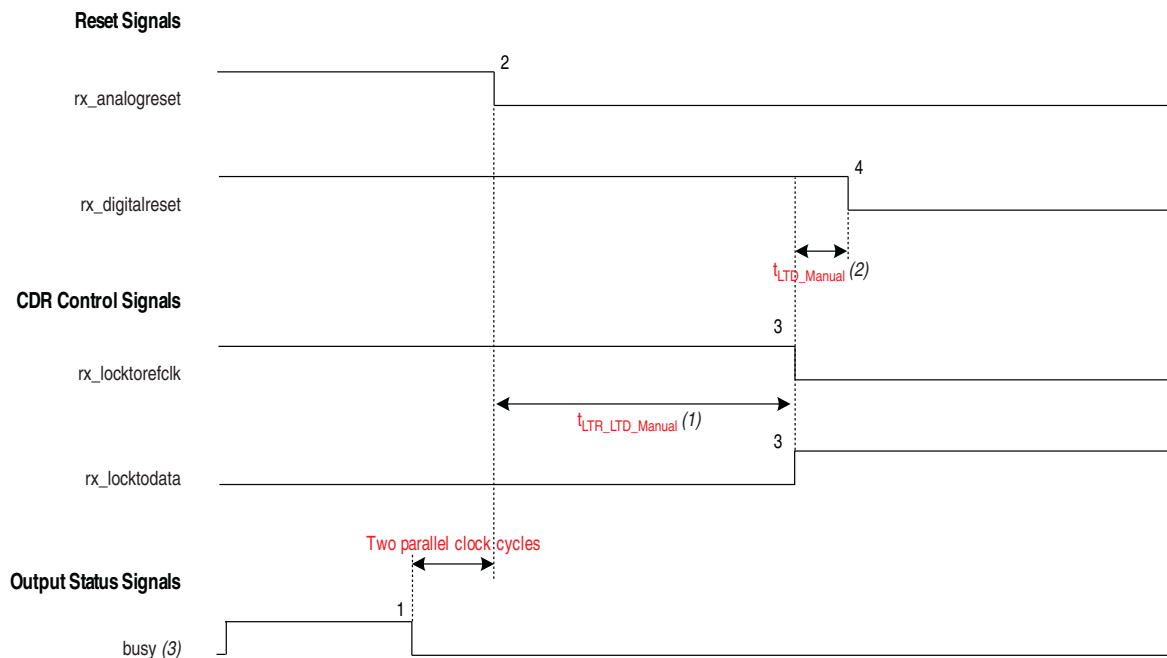

#### Notes to [Figure 2-7](#):

- (1) For  $t_{LTR\_LTD\_Manual}$  duration, refer to the [Cyclone IV Device Datasheet](#) chapter.
- (2) For  $t_{LTD\_Manual}$  duration, refer to the [Cyclone IV Device Datasheet](#) chapter.
- (3) The `busy` signal is asserted and deasserted only during initial power up when offset cancellation occurs. In subsequent reset sequences, the `busy` signal is asserted and deasserted only if there is a read or write operation to the ALTGX\_RECONFIG megafunction.

As shown in [Figure 2-7](#), perform the following reset procedure for the receiver CDR in manual lock mode:

1. After power up, wait for the `busy` signal to be asserted.
2. Keep the `rx_digitalreset` and `rx_locktorefclk` signals asserted and the `rx_locktodata` signal deasserted during this time period.
3. After deassertion of the `busy` signal (marker 1), wait for two parallel clock cycles to deassert the `rx_analogreset` signal (marker 2). After `rx_analogreset` deassert, `rx_pll_locked` will assert.
4. Wait for at least  $t_{LTR\_LTD\_Manual}$ , then deassert the `rx_locktorefclk` signal. At the same time, assert the `rx_locktodata` signal (marker 3).
5. Deassert `rx_digitalreset` at least  $t_{LTD\_Manual}$  (the time between markers 3 and 4) after asserting the `rx_locktodata` signal. At this point, the receiver is ready to receive data.

### Receiver and Transmitter Channel—Receiver CDR in Automatic Lock Mode

This configuration contains both a transmitter and a receiver channel. If you create a **Receiver and Transmitter** instance in the ALTGX MegaWizard Plug-In Manager with the receiver CDR in automatic lock mode, use the reset sequence shown in [Figure 2-8](#).

**Figure 2-8. Sample Reset Sequence of Receiver and Transmitter Channel—Receiver CDR in Automatic Lock Mode**

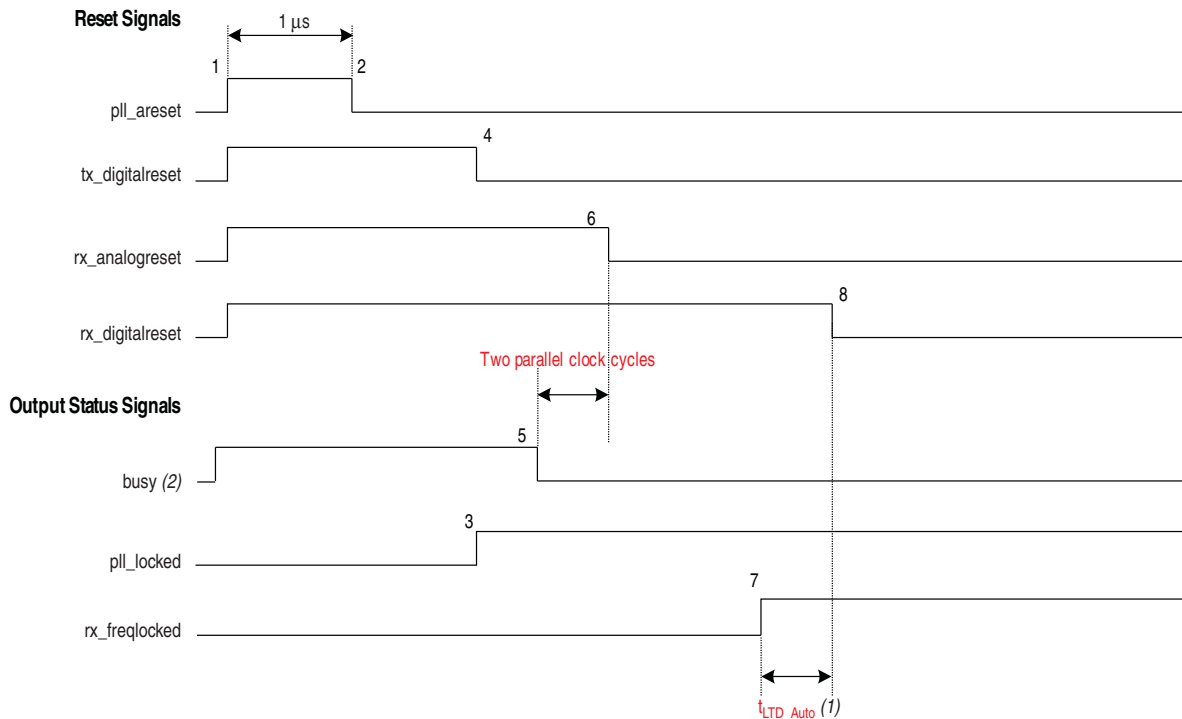

**Notes to Figure 2-8:**

- (1) For  $t_{LTD\_Auto}$  duration, refer to the *Cyclone IV Device Datasheet* chapter.
- (2) The `busy` signal is asserted and deasserted only during initial power up when offset cancellation occurs. In subsequent reset sequences, the `busy` signal is asserted and deasserted only if there is a read or write operation to the ALTGX\_RECONFIG megafunction.

As shown in [Figure 2-8](#), perform the following reset procedure for the receiver in CDR automatic lock mode:

1. After power up, assert `pll_areset` for a minimum period of 1  $\mu$ s (the time between markers 1 and 2).
2. Keep the `tx_digitalreset`, `rx_analogreset`, and `rx_digitalreset` signals asserted during this time period. After you deassert the `pll_areset` signal, the multipurpose PLL starts locking to the transmitter input reference clock.
3. After the multipurpose PLL locks, as indicated by the `pll_locked` signal going high (marker 3), deassert `tx_digitalreset`. For receiver operation, after deassertion of `busy` signal, wait for two parallel clock cycles to deassert the `rx_analogreset` signal.
4. Wait for the `rx_freqlocked` signal to go high (marker 7).
5. After the `rx_freqlocked` signal goes high, wait for at least  $t_{LTD\_Auto}$  then deassert the `rx_digitalreset` signal (marker 8). At this point, the transmitter and receiver are ready for data traffic.

**Receiver and Transmitter Channel—Receiver CDR in Manual Lock Mode**

This configuration contains both a transmitter and receiver channel. If you create a **Receiver and Transmitter** instance in the ALTGX MegaWizard Plug-In Manager with the receiver CDR in manual lock mode, use the reset sequence shown in [Figure 2-9](#).

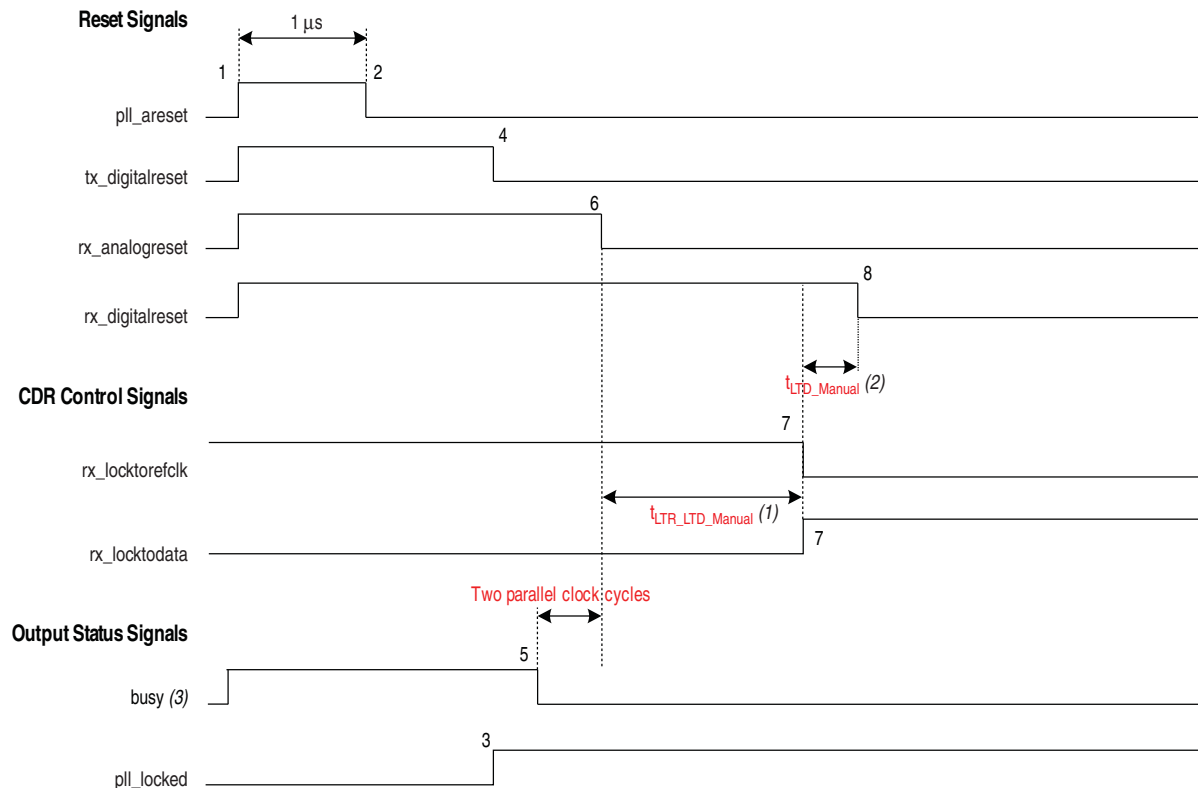
**Figure 2-9. Sample Reset Sequence of Receiver and Transmitter Channel—Receiver CDR in Manual Lock Mode****Notes to Figure 2-9:**

- (1) For  $t_{LTR\_LTD\_Manual}$  duration, refer to the *Cyclone IV Device Datasheet* chapter.
- (2) For  $t_{LTD\_Manual}$  duration, refer to the *Cyclone IV Device Datasheet* chapter.
- (3) The `busy` signal is asserted and deasserted only during initial power up when offset cancellation occurs. In subsequent reset sequences, the `busy` signal is asserted and deasserted only if there is a read or write operation to the ALTGX\_RECONFIG megafunction.

As shown in [Figure 2-9](#), perform the following reset procedure for the receiver in manual lock mode:

1. After power up, assert `pll_areset` for a minimum period of 1  $\mu$ s (the time between markers 1 and 2).
2. Keep the `tx_digitalreset`, `rx_analogreset`, `rx_digitalreset`, and `rx_locktoefclk` signals asserted and the `rx_locktodata` signal deasserted during this time period. After you deassert the `pll_areset` signal, the multipurpose PLL starts locking to the transmitter input reference clock.
3. After the multipurpose PLL locks, as indicated by the `pll_locked` signal going high (marker 3), deassert `tx_digitalreset` (marker 4). For receiver operation, after deassertion of `busy` signal (marker 5), wait for two parallel clock cycles to deassert the `rx_analogreset` signal (marker 6). After `rx_analogreset` deassert, `rx_pll_locked` will assert.

4. Wait for at least  $t_{LTR\_LTD\_Manual}$  (the time between markers 6 and 7), then deassert the `rx_locktorefclk` signal. At the same time, assert the `rx_locktodata` signal (marker 7). At this point, the receiver CDR enters lock-to-data mode and the receiver CDR starts locking to the received data.
5. Deassert `rx_digitalreset` at least  $t_{LTD\_Manual}$  (the time between markers 7 and 8) after asserting the `rx_locktodata` signal. At this point, the transmitter and receiver are ready for data traffic.

### Reset Sequence in Loss of Link Conditions

Loss of link can occur due to loss of local reference clock source or loss of the link due to an unplugged cable. Other adverse conditions like loss of power could also cause the loss of signal from the other device or link partner.

#### Loss of Local REFCLK or Other Reference Clock Condition

Should local reference clock input become disabled or unstable, take the following steps:

1. Monitor `p11_locked` signal. `P11_locked` is de-asserted if local reference clock source becomes unavailable.
2. `P11_locked` assertion indicates a stable reference clock because TX PLL locks to the incoming clock. You can follow appropriate reset sequence provided in the device handbook, starting from `p11_locked` assertion.

#### Loss of Link Due To Unplugged Cable or Far End Shut-off Condition

Use one or more of the following methods to identify whether link partner is alive:

- Signal detect is available in PCIe and Basic modes. You can monitor `rx_signaldetect` signal as loss of link indicator. `rx_signaldetect` is asserted when the link partner comes back up.
- You can implement a ppm detector in device core for modes that do not have signal detect to monitor the link. Ppm detector helps in identifying whether the link is alive.
- Data corruption or RX phase comp FIFO overflow or underflow condition in user logic may indicate a loss of link condition.

Apply the following reset sequences when loss of link is detected:

- For Automatic CDR lock mode:
  - a. Monitor `rx_freqlocked` signal. Loss of link causes `rx_freqlocked` to be de-asserted when CDR moves back to lock-to-data (LTD) mode.
  - b. Assert `rx_digitalreset`.
  - c. `rx_freqlocked` toggles over time when CDR switches between lock-to-reference (LTR) and LTD modes.
  - d. If `rx_freqlocked` goes low at any point, re-assert `rx_digitalreset`.
  - e. If data corruption or RX phase comp FIFO overflow or underflow condition is observed in user logic, assert `rx_digitalreset` for 2 parallel clock cycles, then de-assert the signal.

This solution may violate some of the protocol specific requirements. In such case, you can use Manual CDR lock option.

- For Manual CDR lock mode, `rx_freqlocked` signal is not available. Upon detection of a dead link, take the following steps:
  - a. Switch to LTR mode.
  - b. Assert `rx_digitalreset`.
  - c. Wait for `rx_pll_locked` to go high.
  - d. When you detect incoming data on the receive pins, switch to LTD mode.
  - e. Wait for a duration of  $t_{LTD\_Manual}$ , which is the time taken to recover valid data after the `rx_locktodata` signal is asserted in manual mode.
  - f. De-assert `rx_digitalreset`.

## PCIe Functional Mode

You can configure PCIe functional mode with or without the receiver clock rate compensation FIFO in the Cyclone IV GX device. The reset sequence remains the same whether or not you use the receiver clock rate compensation FIFO.

### PCIe Reset Sequence

The PCIe protocol consists of an initialization/compliance phase and a normal operation phase. The reset sequences for these two phases are described based on the timing diagram in Figure 2-10.

**Figure 2-10. Reset Sequence of PCIe Functional Mode (1), (2)**

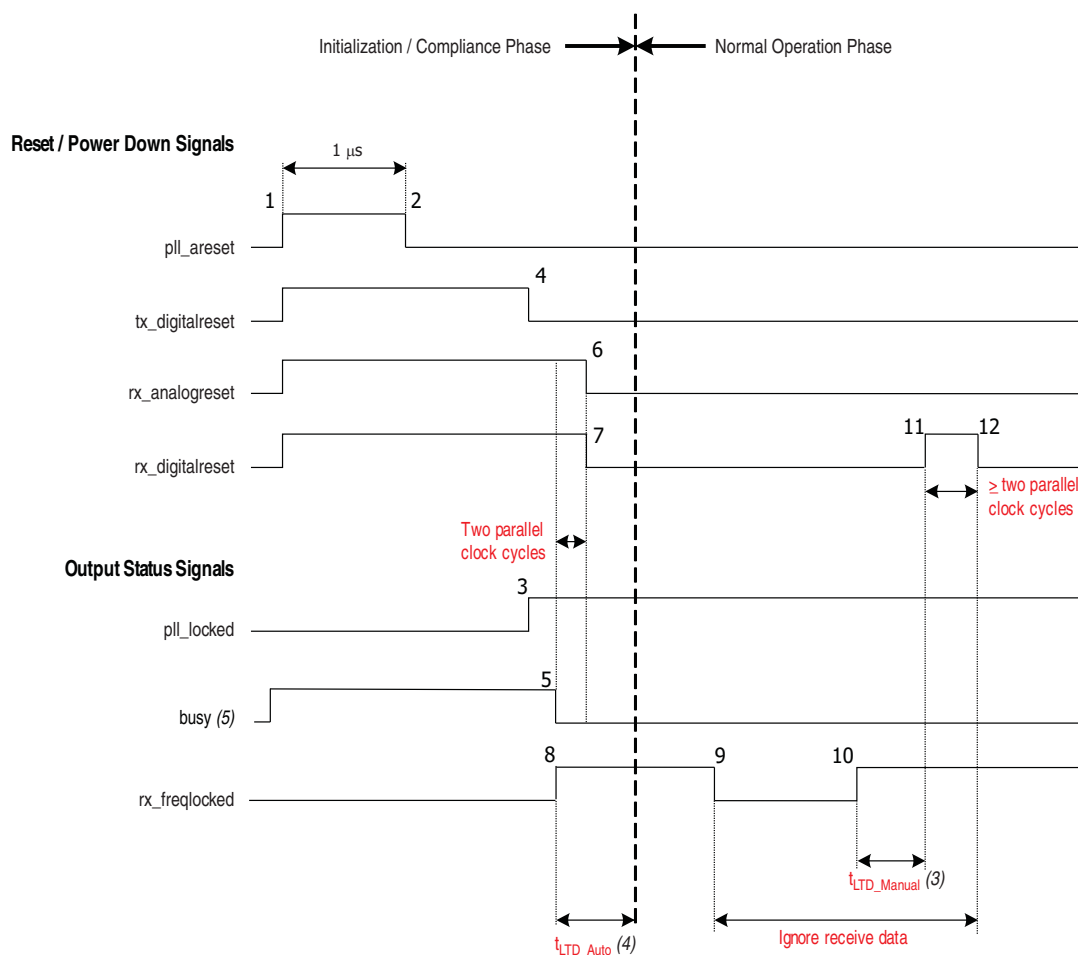

**Notes to Figure 2-10:**

- (1) This timing diagram is drawn based on the PCIe Gen 1 ×1 mode.
- (2) For bonded PCIe Gen 1 ×2 and ×4 modes, there will be additional rx\_freqlocked[n] signal. n=number of channels.
- (3) For t<sub>LTD\_Manual</sub> duration, refer to the *Cyclone IV Device Datasheet* chapter.
- (4) For t<sub>LTD\_Auto</sub> duration, refer to the *Cyclone IV Device Datasheet* chapter.
- (5) The busy signal is asserted and deasserted only during initial power up when offset cancellation occurs. In subsequent reset sequences, the busy signal is asserted and deasserted only if there is a read or write operation to the ALTGX\_RECONFIG megafunction.

## PCIe Initialization/Compliance Phase

After the device is powered up, a PCIe-compliant device goes through the compliance phase during initialization. The `rx_digitalreset` signal must be deasserted during this compliance phase to achieve transitions on the `pipephydonestatus` signal, as expected by the link layer. The `rx_digitalreset` signal is deasserted based on the assertion of the `rx_freqlocked` signal.

During the initialization/compliance phase, do not use the `rx_freqlocked` signal to trigger a deassertion of the `rx_digitalreset` signal. Instead, perform the following reset sequence:

1. After power up, assert `p11_areset` for a minimum period of 1  $\mu$ s (the time between markers 1 and 2). Keep the `tx_digitalreset`, `rx_analogreset`, and `rx_digitalreset` signals asserted during this time period. After you deassert the `p11_areset` signal, the multipurpose PLL starts locking to the input reference clock.
2. After the multipurpose PLL locks, as indicated by the `p11_locked` signal going high (marker 3), deassert `tx_digitalreset`. For a receiver operation, after deassertion of `busy` signal, wait for two parallel clock cycles to deassert the `rx_analogreset` signal. After `rx_analogreset` is deasserted, the receiver CDR starts locking to the receiver input reference clock.
3. Deassert both the `rx_analogreset` signal (marker 6) and `rx_digitalreset` signal (marker 7) together, as indicated in [Figure 2-10](#). After deasserting `rx_digitalreset`, the `pipephydonestatus` signal transitions from the transceiver channel to indicate the status to the link layer. Depending on its status, `pipephydonestatus` helps with the continuation of the compliance phase. After successful completion of this phase, the device enters into the normal operation phase.

## PCIe Normal Phase

For the normal PCIe phase:

1. After completion of the Initialization/Compliance phase, during the normal operation phase at the Gen1 data rate, when the `rx_freqlocked` signal is deasserted (marker 9 in [Figure 2-10](#)).
2. Wait for the `rx_freqlocked` signal to go high again. In this phase, the received data is valid (not electrical idle) and the receiver CDR locks to the incoming data. Proceed with the reset sequence after assertion of the `rx_freqlocked` signal.
3. After the `rx_freqlocked` signal goes high, wait for at least  $t_{LTD\_Manual}$  before asserting `rx_digitalreset` (marker 12 in [Figure 2-10](#)) for two parallel receive clock cycles so that the receiver phase compensation FIFO is initialized. For bonded PCIe Gen 1 mode ( $\times 2$  and  $\times 4$ ), wait for all the `rx_freqlocked` signals to go high, then wait for  $t_{LTD\_Manual}$  before asserting `rx_digitalreset` for 2 parallel clock cycles.

## Dynamic Reconfiguration Reset Sequences

When using dynamic reconfiguration in data rate divisions in PLL reconfiguration or channel reconfiguration mode, use the following reset sequences.

### Reset Sequence in PLL Reconfiguration Mode

Use the example reset sequence shown in Figure 2-11 when you use the PLL dynamic reconfiguration controller to change the data rate of the transceiver channel. In this example, PLL dynamic reconfiguration is used to dynamically reconfigure the data rate of the transceiver channel configured in Basic  $\times 1$  mode with the receiver CDR in automatic lock mode.

**Figure 2-11. Reset Sequence When Using the PLL Dynamic Reconfiguration Controller to Change the Data Rate of the Transceiver Channel**

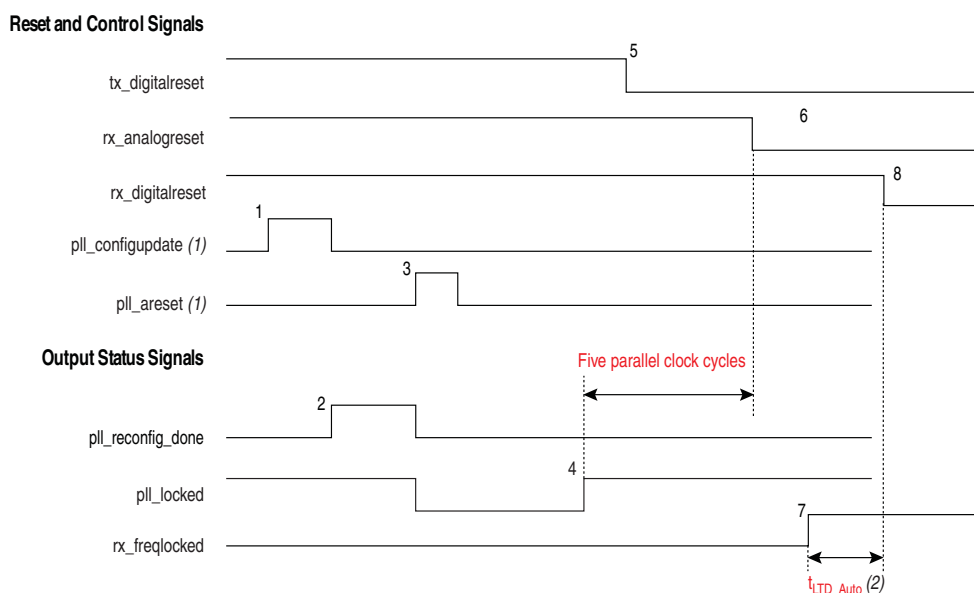

**Notes to Figure 2-11:**

- (1) The `pll_configupdate` and `pll_areset` signals are driven by the `ALTPLL_RECONFIG` megafunction. For more information, refer to *AN 609: Implementing Dynamic Reconfiguration in Cyclone IV GX Devices* and the *Cyclone IV Dynamic Reconfiguration* chapter.
- (2) For  $t_{LTD\_Auto}$  duration, refer to the *Cyclone IV Device Datasheet* chapter.

As shown in Figure 2-11, perform the following reset procedure when using the PLL dynamic reconfiguration controller to change the configuration of the PLLs in the transmitter channel:

1. Assert the `tx_digitalreset`, `rx_analogreset`, and `rx_digitalreset` signals. The `pll_configupdate` signal is asserted (marker 1) by the `ALTPLL_RECONFIG` megafunction after the final data bit is sent out. The `pll_reconfig_done` signal is asserted (marker 2) to inform the `ALTPLL_RECONFIG` megafunction that the scan chain process is completed. The `ALTPLL_RECONFIG` megafunction then asserts the `pll_areset` signal (marker 3) to reset the transceiver PLL.

2. After the PLL is reset, wait for the `p11_locked` signal to go high (marker 4) indicating that the PLL is locked to the input reference clock. After the assertion of the `p11_locked` signal, deassert the `tx_digitalreset` signal (marker 5).
3. Wait at least five parallel clock cycles after the `p11_locked` signal is asserted to deassert the `rx_analogreset` signal (marker 6).
4. When the `rx_freqlocked` signal goes high (marker 7), from that point onwards, wait for at least  $t_{LTD\_Auto}$  time, then deassert the `rx_digitalreset` signal (marker 8). At this point, the receiver is ready for data traffic.

## Reset Sequence in Channel Reconfiguration Mode

Use the example reset sequence shown in [Figure 2-12](#) when you are using the dynamic reconfiguration controller to change the PCS settings of the transceiver channel. In this example, the dynamic reconfiguration controller is used to dynamically reconfigure the transceiver channel configured in Basic  $\times 1$  mode with receiver CDR in automatic lock mode.

**Figure 2-12. Reset Sequence When Using the Dynamic Reconfiguration Controller to Change the PCS Settings of the Transceiver Channel**

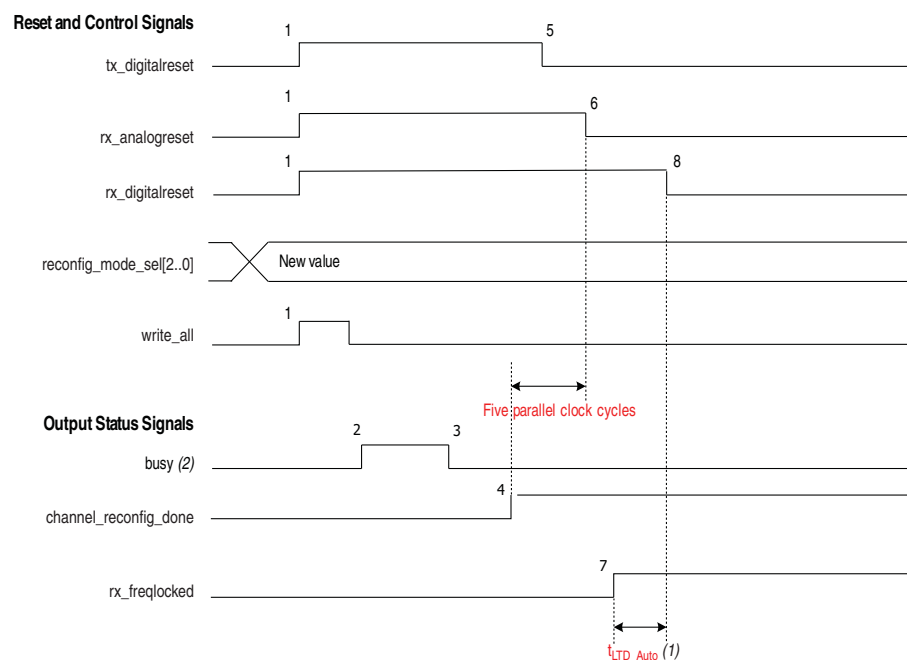

### Notes to Figure 2-12:

- (1) For  $t_{LTD\_Auto}$  duration, refer to the [Cyclone IV Device Datasheet](#) chapter.
- (2) The `busy` signal is asserted and deasserted only during initial power up when offset cancellation occurs. In subsequent reset sequences, the `busy` signal is asserted and deasserted only if there is a read or write operation to the ALTGX\_RECONFIG megafunction.

As shown in [Figure 2-12](#), perform the following reset procedure when using the dynamic reconfiguration controller to change the configuration of the transceiver channel:

1. After power up and establishing that the transceiver is operating as desired, write the desired new value in the appropriate registers (including `reconfig_mode_sel[2:0]`) and subsequently assert the `write_all` signal (marker 1) to initiate the dynamic reconfiguration.

 For more information, refer to the [Cyclone IV Dynamic Reconfiguration](#) chapter.

2. Assert the `tx_digitalreset`, `rx_analogreset`, and `rx_digitalreset` signals.
3. As soon as `write_all` is asserted, the dynamic reconfiguration controller starts to execute its operation. This is indicated by the assertion of the `busy` signal (marker 2).
4. Wait for the assertion of the `channel_reconfig_done` signal (marker 4) that indicates the completion of dynamic reconfiguration in this mode.
5. Deassert the `tx_digitalreset` signal (marker 5). This signal must be deasserted after assertion of the `channel_reconfig_done` signal (marker 4) and before the deassertion of the `rx_analogreset` signal (marker 6).
6. Wait for at least five parallel clock cycles after assertion of the `channel_reconfig_done` signal (marker 4) to deassert the `rx_analogreset` signal (marker 6).
7. Lastly, wait for the `rx_freqlocked` signal to go high. After `rx_freqlocked` goes high (marker 7), wait for  $t_{LTD\_Auto}$  to deassert the `rx_digitalreset` signal (marker 8). At this point, the receiver is ready for data traffic.

## Power Down

The Quartus II software automatically selects the power-down channel feature, which takes effect when you configure the Cyclone IV GX device. All unused transceiver channels and blocks are powered down to reduce overall power consumption. The `gxb_powerdown` signal is an optional transceiver block signal. It powers down all transceiver channels and all functional blocks in the transceiver block. The minimum pulse width for this signal is 1  $\mu$ s. After power up, if you use the `gxb_powerdown` signal, wait for deassertion of the `busy` signal, then assert the `gxb_powerdown` signal for a minimum of 1  $\mu$ s. Lastly, follow the sequence shown in [Figure 2-13](#).

The deassertion of the busy signal indicates proper completion of the offset cancellation process on the receiver channel.

**Figure 2–13. Sample Reset Sequence of a Receiver and Transmitter Channels-Receiver CDR in Automatic Lock Mode with the Optional gxb\_powerdown Signal <sup>(1)</sup>**

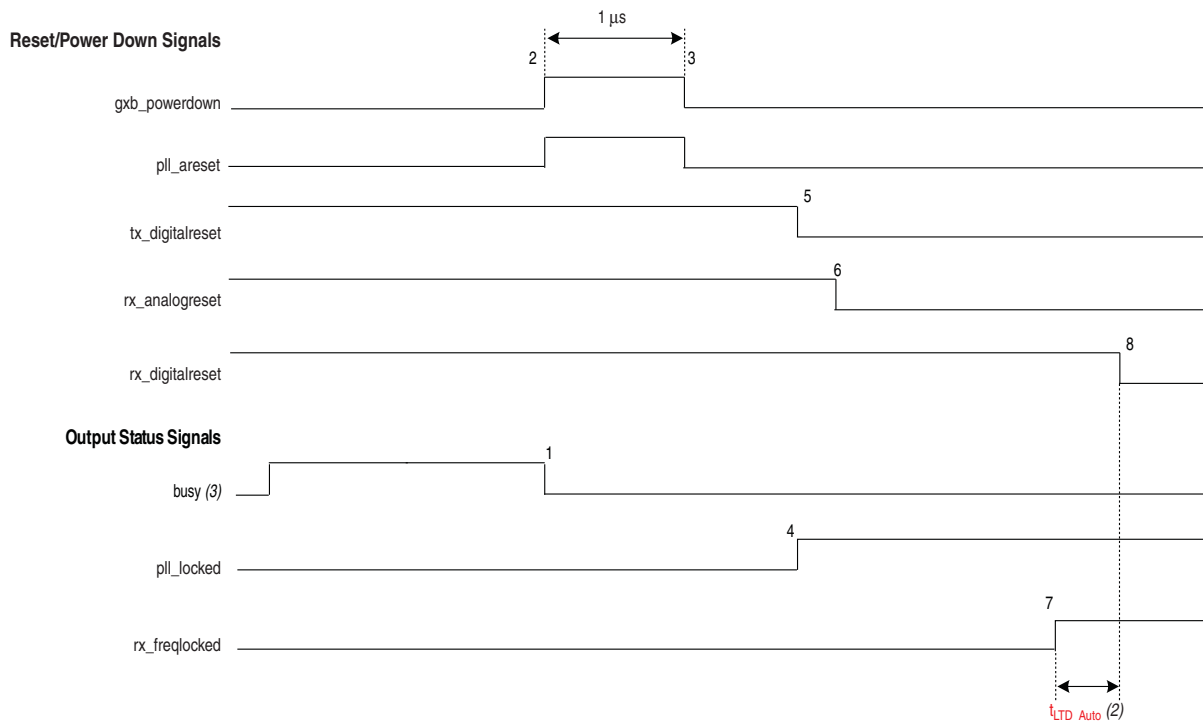

**Notes to Figure 2–13:**

- (1) The `gxb_powerdown` signal must not be asserted during the offset cancellation sequence.
- (2) For  $t_{LTD\_Auto}$  duration, refer to the *Cyclone IV Device Datasheet* chapter.
- (3) The `busy` signal is asserted and deasserted only during initial power up when offset cancellation occurs. In subsequent reset sequences, the `busy` signal is asserted and deasserted only if there is a read or write operation to the `ALTGX_RECONFIG` megafunction.

## Simulation Requirements

The following are simulation requirements:

- The `gxb_powerdown` port is optional. In simulation, if the `gxb_powerdown` port is not instantiated, you must assert the `tx_digitalreset`, `rx_digitalreset`, and `rx_analogreset` signals appropriately for correct simulation behavior.
- If the `gxb_powerdown` port is instantiated, and the other reset signals are not used, you must assert the `gxb_powerdown` signal for at least 1  $\mu$ s for correct simulation behavior.
- You can deassert the `rx_digitalreset` signal immediately after the `rx_freqlocked` signal goes high to reduce the simulation run time. It is not necessary to wait for  $t_{LTD\_Auto}$  (as suggested in the actual reset sequence).
- The `busy` signal is deasserted after about 20 parallel `reconfig_clk` clock cycles in order to reduce simulation run time. For silicon behavior in hardware, you can follow the reset sequences described in the previous pages.

- In PCIe mode simulation, you must assert the `tx_forceidle` signal for at least one parallel clock cycle before transmitting normal data for correct simulation behavior.

## Reference Information

For more information about some useful reference terms used in this chapter, refer to the links listed in [Table 2-7](#).

**Table 2-7. Reference Information**

Terms Used in this Chapter	Useful Reference Points
Automatic Lock Mode	<a href="#">page 2-8</a>
Bonded channel configuration	<a href="#">page 2-6</a>
<code>busy</code>	<a href="#">page 2-3</a>
Dynamic Reconfiguration Reset Sequences	<a href="#">page 2-19</a>
<code>gxb_powerdown</code>	<a href="#">page 2-3</a>
LTD	<a href="#">page 2-6</a>
LTR	<a href="#">page 2-6</a>
Manual Lock Mode	<a href="#">page 2-9</a>
Non-Bonded channel configuration	<a href="#">page 2-10</a>
PCIe	<a href="#">page 2-17</a>
<code>pll_locked</code>	<a href="#">page 2-3</a>
<code>pll_aret</code>	<a href="#">page 2-3</a>
<code>rx_analogreset</code>	<a href="#">page 2-2</a>
<code>rx_digitalreset</code>	<a href="#">page 2-2</a>
<code>rx_freqlocked</code>	<a href="#">page 2-3</a>
<code>tx_digitalreset</code>	<a href="#">page 2-2</a>

## Document Revision History

Table 2-8 lists the revision history for this chapter.

**Table 2-8. Document Revision History**

Date	Version	Changes
September 2014	1.4	<ul style="list-style-type: none"> <li>■ Removed the <code>rx_pll_locked</code> signal from the “Sample Reset Sequence of Receiver Only Channel—Receiver CDR in Manual Lock Mode” and the “Sample Reset Sequence of Receiver and Transmitter Channel—Receiver CDR in Manual Lock Mode” figures.</li> </ul>
May 2013	1.3	<ul style="list-style-type: none"> <li>■ Added <code>rx_pll_locked</code> to Figure 2-7 and Figure 2-9.</li> <li>■ Added information on <code>rx_pll_locked</code> to “Receiver Only Channel—Receiver CDR in Manual Lock Mode” and “Receiver and Transmitter Channel—Receiver CDR in Manual Lock Mode”.</li> </ul>
November 2011	1.2	Updated the “All Supported Functional Modes Except the PCIe Functional Mode” section.
December 2010	1.1	<ul style="list-style-type: none"> <li>■ Updated for the Quartus II software version 10.1 release.</li> <li>■ Updated all <code>pll_powerdown</code> to <code>pll_aret</code>.</li> <li>■ Added information about the <code>busy</code> signal in Figure 2-4, Figure 2-5, Figure 2-6, Figure 2-7, Figure 2-8, Figure 2-9, Figure 2-10, Figure 2-12, and Figure 2-13.</li> <li>■ Added information for clarity (“Receiver and Transmitter Channel—Receiver CDR in Manual Lock Mode”, “Receiver Only Channel—Receiver CDR in Automatic Lock Mode”, “Receiver Only Channel—Receiver CDR in Manual Lock Mode”, “Receiver and Transmitter Channel—Receiver CDR in Manual Lock Mode”, and “Reset Sequence in Channel Reconfiguration Mode”).</li> <li>■ Minor text edits.</li> </ul>
July 2010	1.0	Initial release.

Cyclone® IV GX transceivers allow you to dynamically reconfigure different portions of the transceivers without powering down any part of the device. This chapter describes and provides examples about the different modes available for dynamic reconfiguration.

You can use the ALTGX\_RECONFIG and ALTPLL\_RECONFIG controller instance to reconfigure the physical medium attachment (PMA) controls, physical coding sublayer (PCS), multipurpose phase locked loops (PLLs), and general purpose PLLs.

This chapter contains the following sections:

- “Glossary of Terms” on page 3–1
- “Dynamic Reconfiguration Controller Architecture” on page 3–2
- “Dynamic Reconfiguration Modes” on page 3–12
- “Error Indication During Dynamic Reconfiguration” on page 3–36
- “Functional Simulation of the Dynamic Reconfiguration Process” on page 3–37

## Glossary of Terms

Table 3–1 lists the terms used in this chapter:

**Table 3–1. Glossary of Terms Used in this Chapter (Part 1 of 2)**

Term	Description
ALTGX_RECONFIG Instance	Dynamic reconfiguration controller instance generated by the ALTGX_RECONFIG MegaWizard™ Plug-In Manager.
ALTGX Instance	Transceiver instance generated by the ALTGX MegaWizard Plug-In Manager.
ALTPLL_RECONFIG Instance	Dynamic PLL reconfiguration controller instance generated by the ALTPLL_RECONFIG Megawizard Plug-In Manager
Logical Channel Addressing	Used whenever the concept of logical channel addressing is explained. This term does not refer to the <code>logical_channel_address</code> port available in the ALTGX_RECONFIG MegaWizard Plug-In Manager.

**Table 3-1. Glossary of Terms Used in this Chapter (Part 2 of 2)**

Term	Description
Memory Initialization File, also known as <b>.mif</b>	<p>A file with the <b>.mif</b> extension will be generated for <b>.mif</b>-based reconfiguration mode. It can be either in Channel Reconfiguration mode or PLL Reconfiguration mode.</p> <ul style="list-style-type: none"> <li>■ Channel Reconfiguration mode—this file contains information about the various ALTGX MegaWizard Plug-In Manager options that you set. Each word in the <b>.mif</b> is 16 bits wide. The dynamic reconfiguration controller writes information from the <b>.mif</b> into the transceiver channel.</li> <li>■ PLL Reconfiguration mode—this file contains information about the various PLL parameters and settings that you use to configure the transceiver PLL to different output frequency. The <b>.mif</b> file is 144 × 1-bit size. During PLL reconfiguration mode, the PLL reconfiguration controller shifts these 144-bit serially into the transceiver PLL.</li> </ul>
PMA controls	Represents <b>analog controls (Voltage Output Differential [V<sub>OD</sub>], Pre-emphasis, DC Gain, and Manual Equalization)</b> as displayed in both the ALTGX and ALTGX_RECONFIG MegaWizard Plug-In Managers.
Transceiver channel	Refers to a transmitter channel, a receiver channel, or a duplex channel that has both PMA and PCS blocks.

## Dynamic Reconfiguration Controller Architecture

The dynamic reconfiguration controller is a soft intellectual property (IP) that utilizes FPGA-fabric resources. You can use only one controller per transceiver block. You cannot use the dynamic reconfiguration controller to control multiple Cyclone IV devices or any off-chip interfaces.

Figure 3-1 shows a conceptual view of the dynamic reconfiguration controller architecture. For a detailed description of the inputs and outputs of the ALTGX\_RECONFIG instance, refer to “Error Indication During Dynamic Reconfiguration” on page 3-36.

**Figure 3-1. Dynamic Reconfiguration Controller**

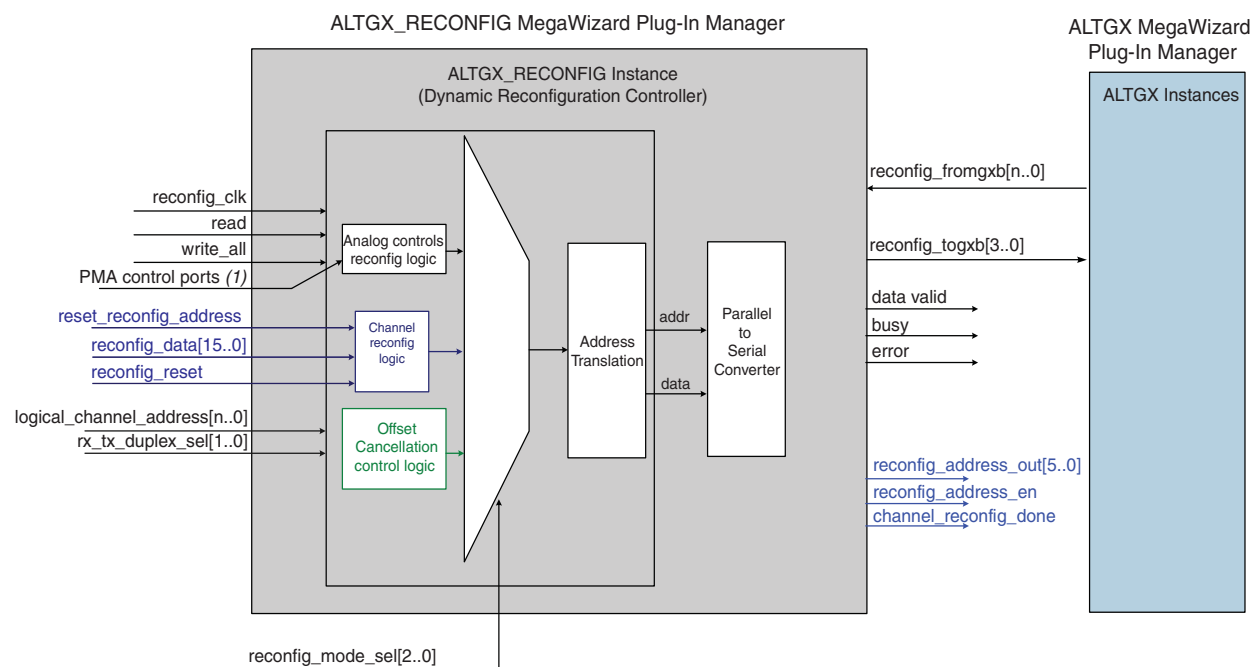

**Note to Figure 3-1:**

(1) The PMA control ports consist of the  $V_{00}$ , pre-emphasis, DC gain, and manual equalization controls.

 Only PMA reconfiguration mode supports manual equalization controls.

 You can use one ALTGX\_RECONFIG instance to control multiple transceiver blocks. However, you cannot use multiple ALTGX\_RECONFIG instances to control one transceiver block.

## Dynamic Reconfiguration Controller Port List

Table 3–2 lists the input control ports and output status ports of the dynamic reconfiguration controller.

**Table 3–2. Dynamic Reconfiguration Controller Port List (ALTGX\_RECONFIG Instance) (Part 1 of 7)**

Port Name	Input/ Output	Description
<b>Clock Inputs to ALTGX_RECONFIG Instance</b>		
reconfig_clk	Input	<p>The frequency range of this clock depends on the following transceiver channel configuration modes:</p> <ul style="list-style-type: none"> <li>■ <b>Receiver only</b> (37.5 MHz to 50 MHz)</li> <li>■ <b>Receiver and Transmitter</b> (37.5 MHz to 50 MHz)</li> <li>■ <b>Transmitter only</b> (2.5 MHz to 50 MHz)</li> </ul> <p>By default, the Quartus® II software assigns a global clock resource to this port. This clock must be a free-running clock sourced from an I/O clock pin. Do not use dedicated transceiver REFCLK pins or any clocks generated by transceivers.</p>
<b>ALTGX and ALTGX_RECONFIG Interface Signals</b>		
reconfig_fromgxb [n..0]	Input	<p>An output port in the ALTGX instance and an input port in the ALTGX_RECONFIG instance. This signal is transceiver-block based. Therefore, the width of this signal increases in steps of 5 bits per transceiver block.</p> <p>In the ALTGX MegaWizard Plug-In Manager, the width of this signal depends on the number of channels you select in the <b>What is the number of channels?</b> option in the <b>General</b> screen.</p> <p>For example, if you select the number of channels in the ALTGX instance as follows:</p> <p>1 ≤ Channels ≤ 4, then the output port reconfig_fromgxb[4..0] = 5 bits</p> <p>5 ≤ Channels ≤ 8, then the output port reconfig_fromgxb[9..0] = 10 bits</p> <p>9 ≤ Channels ≤ 12, then the output port reconfig_fromgxb[14..0] = 15 bits</p> <p>13 ≤ Channels ≤ 16, then the output port reconfig_fromgxb[19..0] = 20 bits</p> <p>To connect the reconfig_fromgxb port between the ALTGX_RECONFIG instance and multiple ALTGX instances, follow these rules:</p> <ul style="list-style-type: none"> <li>■ Connect the reconfig_fromgxb[4..0] of ALTGX Instance 1 to the reconfig_fromgxb[4..0] of the ALTGX_RECONFIG instance. Connect the reconfig_fromgxb[] port of the next ALTGX instance to the next available bits of the ALTGX_RECONFIG instance, and so on.</li> <li>■ Connect the reconfig_fromgxb port of the ALTGX instance, which has the highest <b>What is the starting channel number?</b> option, to the MSB of the reconfig_fromgxb port of the ALTGX_RECONFIG instance.</li> </ul> <p>The Quartus II Fitter produces a warning if the dynamic reconfiguration option is enabled in the ALTGX instance but the reconfig_fromgxb and reconfig_togxb ports are not connected to the ALTGX_RECONFIG instance.</p>
reconfig_togxb [3..0]	Output	<p>An input port of the ALTGX instance and an output port of the ALTGX_RECONFIG instance. You must connect the reconfig_togxb[3..0] input port of every ALTGX instance controlled by the dynamic reconfiguration controller to the reconfig_togxb[3..0] output port of the ALTGX_RECONFIG instance.</p> <p>The width of this port is always fixed to 4 bits.</p>

**Table 3–2. Dynamic Reconfiguration Controller Port List (ALTGX\_RECONFIG Instance) (Part 2 of 7)**

Port Name	Input/ Output	Description
<b>FPGA Fabric and ALTGX_RECONFIG Interface Signals</b>		
write_all	Input	<p>Assert this signal for one <code>reconfig_clk</code> clock cycle to initiate a write transaction from the ALTGX_RECONFIG instance to the ALTGX instance.</p> <p>You can use this signal in two ways for <code>.mif</code>-based modes:</p> <ul style="list-style-type: none"> <li>■ Continuous write operation—select the <b>Enable continuous write of all the words needed for reconfiguration</b> option to pulse the <code>write_all</code> signal only once for writing a whole <code>.mif</code>. The <b>What is the read latency of the MIF contents</b> option is available for selection in this case only. Enter the desired latency in terms of the <code>reconfig_clk</code> cycles.</li> <li>■ Regular write operation—when the <b>Enable continuous write of all the words needed for reconfiguration</b> option is disabled, every word of the <code>.mif</code> requires its own write cycle.</li> </ul>
busy	Output	<p>This signal is used to indicate the busy status of the dynamic reconfiguration controller during offset cancellation. After the device powers up, this signal remains low for the first <code>reconfig_clk</code> clock cycle. It then is asserted and remains high when the dynamic reconfiguration controller performs offset cancellation on all the receiver channels connected to the ALTGX_RECONFIG instance.</p> <p>Deassertion of the <code>busy</code> signal indicates the successful completion of the offset cancellation process.</p> <ul style="list-style-type: none"> <li>■ PMA controls reconfiguration mode—this signal is high when the dynamic reconfiguration controller performs a read or write transaction.</li> <li>■ Channel reconfiguration modes—this signal is high when the dynamic reconfiguration controller writes the <code>.mif</code> into the transceiver channel.</li> </ul>
read	Input	<p>Assert this signal for one <code>reconfig_clk</code> clock cycle to initiate a read transaction. The <code>read</code> port is applicable only to the PMA controls reconfiguration mode. The <code>read</code> port is available when you select <b>Analog controls</b> in the <b>Reconfiguration settings</b> screen and select at least one of the PMA control ports in the <b>Analog controls</b> screen.</p>
data_valid	Output	<p>Applicable only to PMA controls reconfiguration mode. This port indicates the validity of the data read from the transceiver by the dynamic reconfiguration controller.</p> <p>The data on the output read ports is valid only when the <code>data_valid</code> is high.</p> <p>This signal is enabled when you enable at least one PMA control port used in read transactions, for example <code>tx_vodctrl_out</code>.</p>
error	Output	<p>This indicates that an unsupported operation was attempted. You can select this in the <b>Error checks</b> screen. The dynamic reconfiguration controller deasserts the <code>busy</code> signal and asserts the <code>error</code> signal for two <code>reconfig_clk</code> cycles when you attempt an unsupported operation. For more information, refer to <a href="#">“Error Indication During Dynamic Reconfiguration” on page 3–36</a>.</p>

**Table 3-2. Dynamic Reconfiguration Controller Port List (ALTGX\_RECONFIG Instance) (Part 3 of 7)**

Port Name	Input/Output	Description										
logical_channel_address[n..0]	Input	<p>Enabled by the ALTGX_RECONFIG MegaWizard Plug-In Manager when you enable the <b>Use 'logical_channel_address' port for Analog controls reconfiguration</b> option in the <b>Analog controls</b> screen.</p> <p>The width of the logical_channel_address port depends on the value you set in the <b>What is the number of channels controlled by the reconfig controller?</b> option in the <b>Reconfiguration settings</b> screen. This port can be enabled only when the number of channels controlled by the dynamic reconfiguration controller is more than one.</p> <table> <tr> <td>Number of channels controlled by the reconfiguration controller</td> <td>logical_channel_address input port width</td> </tr> <tr> <td>2</td> <td>logical_channel_address[0]</td> </tr> <tr> <td>3-4</td> <td>logical_channel_address[1..0]</td> </tr> <tr> <td>5-8</td> <td>logical_channel_address[2..0]</td> </tr> <tr> <td>9-16</td> <td>logical_channel_address[3..0]</td> </tr> </table>	Number of channels controlled by the reconfiguration controller	logical_channel_address input port width	2	logical_channel_address[0]	3-4	logical_channel_address[1..0]	5-8	logical_channel_address[2..0]	9-16	logical_channel_address[3..0]
Number of channels controlled by the reconfiguration controller	logical_channel_address input port width											
2	logical_channel_address[0]											
3-4	logical_channel_address[1..0]											
5-8	logical_channel_address[2..0]											
9-16	logical_channel_address[3..0]											
rx_tx_duplex_sel[1..0]	Input	<p>This is a 2-bit wide signal. You can select this in the <b>Error checks</b> screen.</p> <p>The advantage of using this optional port is that it allows you to reconfigure only the transmitter portion of a channel, even if the channel configuration is duplex.</p> <p>For a setting of:</p> <ul style="list-style-type: none"> <li>■ rx_tx_duplex_sel[1:0] = 2'b00—the transmitter and receiver portion of the channel is reconfigured.</li> <li>■ rx_tx_duplex_sel[1:0] = 2'b01—the receiver portion of the channel is reconfigured.</li> <li>■ rx_tx_duplex_sel[1:0] = 2'b10—the transmitter portion of the channel is reconfigured.</li> </ul>										

**Table 3-2. Dynamic Reconfiguration Controller Port List (ALTGX\_RECONFIG Instance) (Part 4 of 7)**

Port Name	Input/ Output	Description																					
<b>Analog Settings Control/Status Signals</b>																							
tx_vodctrl[2..0] (1)	Input	<p>This is an optional transmit buffer <math>V_{OD}</math> control signal. It is 3 bits per transmitter channel. The number of settings varies based on the transmit buffer supply setting and the termination resistor setting on the <b>TX Analog</b> screen of the ALTGX MegaWizard Plug-In Manager.</p> <p>The width of this signal is fixed to 3 bits if you enable either the <b>Use 'logical_channel_address' port for Analog controls reconfiguration</b> option or the <b>Use same control signal for all the channels</b> option in the <b>Analog controls</b> screen. Otherwise, the width of this signal is 3 bits per channel.</p> <p>The following shows the <math>V_{OD}</math> values corresponding to the tx_vodctrl settings for 100-<math>\Omega</math> termination.</p> <p>For more information, refer to the “Programmable Output Differential Voltage” section of the <i>Cyclone IV GX Device Datasheet</i> chapter.</p> <table border="1" data-bbox="542 756 1456 1081"> <thead> <tr> <th>tx_vodctrl[2:0]</th> <th>Corresponding ALTGX instance settings</th> <th>Corresponding <math>V_{OD}</math> settings (mV)</th> </tr> </thead> <tbody> <tr> <td>3'b001</td> <td>1</td> <td>400</td> </tr> <tr> <td>3'b010</td> <td>2</td> <td>600</td> </tr> <tr> <td>3'b011</td> <td>3</td> <td>800</td> </tr> <tr> <td>3'b111</td> <td>4 (2)</td> <td>900 (2)</td> </tr> <tr> <td>3'b100</td> <td>5</td> <td>1000</td> </tr> <tr> <td>3'b101</td> <td>6</td> <td>1200</td> </tr> </tbody> </table> <p>All other values =&gt; N/A</p>	tx_vodctrl[2:0]	Corresponding ALTGX instance settings	Corresponding $V_{OD}$ settings (mV)	3'b001	1	400	3'b010	2	600	3'b011	3	800	3'b111	4 (2)	900 (2)	3'b100	5	1000	3'b101	6	1200
tx_vodctrl[2:0]	Corresponding ALTGX instance settings	Corresponding $V_{OD}$ settings (mV)																					
3'b001	1	400																					
3'b010	2	600																					
3'b011	3	800																					
3'b111	4 (2)	900 (2)																					
3'b100	5	1000																					
3'b101	6	1200																					

Table 3-2. Dynamic Reconfiguration Controller Port List (ALTGX\_RECONFIG Instance) (Part 5 of 7)

Port Name	Input/ Output	Description																																				
tx_preemp[4..0] <sup>(1)</sup>	Input	<p>This is an optional pre-emphasis write control for the transmit buffer. Depending on what value you set at this input, the controller dynamically writes the value to the pre-emphasis control register of the transmit buffer.</p> <p>The width of this signal is fixed to 5 bits if you enable either the <b>Use 'logical_channel_address' port for Analog controls reconfiguration</b> option or the <b>Use same control signal for all the channels</b> option in the <b>Analog controls</b> screen. Otherwise, the width of this signal is 5 bits per channel.</p> <table> <thead> <tr> <th>tx_preemp[4..0]</th> <th>Corresponding ALTGX instance settings</th> <th>Corresponding pre-emphasis setting (mA)</th> </tr> </thead> <tbody> <tr> <td>00000</td> <td>0</td> <td>Disabled</td> </tr> <tr> <td>00001</td> <td>1</td> <td>0.5</td> </tr> <tr> <td>00101</td> <td>5</td> <td>1.0</td> </tr> <tr> <td>01001</td> <td>9</td> <td>1.5</td> </tr> <tr> <td>01101</td> <td>13</td> <td>2.0</td> </tr> <tr> <td>10000</td> <td>16</td> <td>2.375</td> </tr> <tr> <td>10001</td> <td>17</td> <td>2.5</td> </tr> <tr> <td>10010</td> <td>18</td> <td>2.625</td> </tr> <tr> <td>10011</td> <td>19</td> <td>2.75</td> </tr> <tr> <td>10100</td> <td>20</td> <td>2.875</td> </tr> <tr> <td>10101</td> <td>21</td> <td>3.0</td> </tr> </tbody> </table> <p>All other values =&gt; N/A</p>	tx_preemp[4..0]	Corresponding ALTGX instance settings	Corresponding pre-emphasis setting (mA)	00000	0	Disabled	00001	1	0.5	00101	5	1.0	01001	9	1.5	01101	13	2.0	10000	16	2.375	10001	17	2.5	10010	18	2.625	10011	19	2.75	10100	20	2.875	10101	21	3.0
		tx_preemp[4..0]	Corresponding ALTGX instance settings	Corresponding pre-emphasis setting (mA)																																		
		00000	0	Disabled																																		
		00001	1	0.5																																		
		00101	5	1.0																																		
		01001	9	1.5																																		
		01101	13	2.0																																		
		10000	16	2.375																																		
		10001	17	2.5																																		
		10010	18	2.625																																		
		10011	19	2.75																																		
		10100	20	2.875																																		
		10101	21	3.0																																		
rx_eqctrl[3..0] <sup>(1)</sup>	Input	<p>This is an optional write control to write an equalization control value for the receive side of the PMA.</p> <p>The width of this signal is fixed to 4 bits if you enable either the <b>Use 'logical_channel_address' port for Analog controls reconfiguration</b> option or the <b>Use same control signal for all the channels</b> option in the <b>Analog controls</b> screen. Otherwise, the width of this signal is 4 bits per channel.</p> <table> <thead> <tr> <th>rx_eqctrl[3..0]</th> <th>Corresponding ALTGX instance settings</th> </tr> </thead> <tbody> <tr> <td>0001</td> <td>Low</td> </tr> <tr> <td>0101</td> <td>Medium Low</td> </tr> <tr> <td>0100</td> <td>Medium High</td> </tr> <tr> <td>0111</td> <td>High</td> </tr> </tbody> </table> <p>All other values =&gt; N/A</p>	rx_eqctrl[3..0]	Corresponding ALTGX instance settings	0001	Low	0101	Medium Low	0100	Medium High	0111	High																										
		rx_eqctrl[3..0]	Corresponding ALTGX instance settings																																			
		0001	Low																																			
		0101	Medium Low																																			
		0100	Medium High																																			
		0111	High																																			

**Table 3-2. Dynamic Reconfiguration Controller Port List (ALTGX\_RECONFIG Instance) (Part 6 of 7)**

Port Name	Input/Output	Description															
rx_eqdcgain [1..0] <sup>(1)</sup>	Input	<p>This is an optional equalizer DC gain write control.</p> <p>The width of this signal is fixed to 2 bits if you enable either the <b>Use 'logical_channel_address' port for Analog controls reconfiguration</b> option or the <b>Use same control signal for all the channels</b> option in the <b>Analog controls</b> screen. Otherwise, the width of this signal is 2 bits per channel.</p> <p>The following values are the legal settings allowed for this signal:</p> <table border="1"> <thead> <tr> <th>rx_eqdcgain[1..0]</th> <th>Corresponding ALTGX settings</th> <th>Corresponding DC Gain value</th> </tr> </thead> <tbody> <tr> <td>(dB)</td> <td></td> <td></td> </tr> <tr> <td>2'b00</td> <td>0</td> <td>0</td> </tr> <tr> <td>2'b01</td> <td>1</td> <td>3 <sup>(2)</sup></td> </tr> <tr> <td>2'b10</td> <td>2</td> <td>6</td> </tr> </tbody> </table> <p>All other values =&gt; N/A</p> <p>For more information, refer to the “Programmable Equalization and DC Gain” section of the <i>Cyclone IV GX Device Datasheet</i> chapter.</p>	rx_eqdcgain[1..0]	Corresponding ALTGX settings	Corresponding DC Gain value	(dB)			2'b00	0	0	2'b01	1	3 <sup>(2)</sup>	2'b10	2	6
rx_eqdcgain[1..0]	Corresponding ALTGX settings	Corresponding DC Gain value															
(dB)																	
2'b00	0	0															
2'b01	1	3 <sup>(2)</sup>															
2'b10	2	6															
tx_vodctrl_out [2..0]	Output	<p>This is an optional transmit V<sub>OD</sub> read control signal. This signal reads out the value written into the V<sub>OD</sub> control register. The width of this output signal depends on the number of channels controlled by the dynamic reconfiguration controller and also the configuration of the <b>Use 'logical_channel_address' port for Analog controls reconfiguration</b> option and the <b>Use same control signal for all the channels</b> option.</p>															
tx_preemp_out [4..0]	Output	<p>This is an optional pre-emphasis read control signal. This signal reads out the value written by its input control signal. The width of this output signal depends on the number of channels controlled by the dynamic reconfiguration controller and also the configuration of the <b>Use 'logical_channel_address' port for Analog controls reconfiguration</b> option and the <b>Use same control signal for all the channels</b> option.</p>															
rx_eqctrl_out [3..0]	Output	<p>This is an optional read control signal to read the setting of equalization setting of the ALTGX instance. The width of this output signal depends on the number of channels controlled by the dynamic reconfiguration controller and also the configuration of the <b>Use 'logical_channel_address' port for Analog controls reconfiguration</b> option and the <b>Use same control signal for all the channels</b> option.</p>															
rx_eqdcgain_out [1..0]	Output	<p>This is an optional equalizer DC gain read control signal. This signal reads out the settings of the ALTGX instance DC gain. The width of this output signal depends on the number of channels controlled by the dynamic reconfiguration controller and also the configuration of the <b>Use 'logical_channel_address' port for Analog controls reconfiguration</b> option and the <b>Use same control signal for all the channels</b> option.</p>															
<b>Transceiver Channel Reconfiguration Control/Status Signals</b>																	
reconfig_mode_sel [2..0] <sup>(3)</sup>	Input	<p>Set the following values at this signal to activate the appropriate dynamic reconfiguration mode:</p> <p>3'b000 = PMA controls reconfiguration mode. This is the default value.</p> <p>3'b001 = Channel reconfiguration mode</p> <p>All other values =&gt; N/A</p> <p>reconfig_mode_sel[] is available as an input only when you enable more than one dynamic reconfiguration mode.</p>															

**Table 3-2. Dynamic Reconfiguration Controller Port List (ALTGX\_RECONFIG Instance) (Part 7 of 7)**

Port Name	Input/Output	Description
reconfig_address_out [5..0]	Output	This signal is always available for you to select in the <b>Channel reconfiguration</b> screen. This signal is applicable only in the dynamic reconfiguration modes grouped under <b>Channel reconfiguration mode</b> including <b>channel interface</b> and <b>Use RX local divider</b> option. This signal represents the current address used by the ALTGX_RECONFIG instance when writing the <b>.mif</b> into the transceiver channel. This signal increments by 1, from 0 to the last address, then starts at 0 again. You can use this signal to indicate the end of all the <b>.mif</b> write transactions ( <code>reconfig_address_out [5..0]</code> changes from the last address to 0 at the end of all the <b>.mif</b> write transactions).
reconfig_address_en	Output	This is an optional signal you can select in the <b>Channel reconfiguration</b> screen. This signal is applicable only in dynamic reconfiguration modes grouped under the <b>Channel reconfiguration</b> option. The dynamic reconfiguration controller asserts <code>reconfig_address_en</code> to indicate that <code>reconfig_address_out [5..0]</code> has changed. This signal is asserted only after the dynamic reconfiguration controller completes writing one 16-bit word of the <b>.mif</b> .
reset_reconfig_address	Input	This is an optional signal you can select in the <b>Channel reconfiguration</b> screen. This signal is applicable only in dynamic reconfiguration modes grouped under the <b>Channel reconfiguration</b> option. Enable this signal and assert it for one <code>reconfig_clk</code> clock cycle if you want to reset the reconfiguration address used by the ALTGX_RECONFIG instance during reconfiguration.
reconfig_data [15..0]	Input	This signal is applicable only in the dynamic reconfiguration modes grouped under the <b>Channel reconfiguration</b> option. This is a 16-bit word carrying the reconfiguration information. It is stored in a <b>.mif</b> that you must generate. The ALTGX_RECONFIG instance requires that you provide <code>reconfig_data [15..0]</code> on every <b>.mif</b> write transaction using the <code>write_all</code> signal.
reconfig_reset <sup>(4)</sup>	Input	You can use this signal to reset all the reconfiguration process in <b>Channel reconfiguration</b> mode. Asserting this port will reset all the register in the reconfiguration controller logics. This port only shows up in <b>Channel reconfiguration</b> mode. If you are feeding into this port, synchronize the reset signal to the <code>reconfig_clk</code> domain.
channel_reconfig_done	Output	This signal goes high to indicate that the dynamic reconfiguration controller has finished writing all the words of the <b>.mif</b> . The <code>channel_reconfig_done</code> signal is automatically deasserted at the start of a new dynamic reconfiguration write sequence. This signal is applicable only in channel reconfiguration mode.

**Notes to Table 3-2:**

- (1) Not all combinations of input bits are legal values.
- (2) This setting is required for compliance to PCI Express® (PIPE) functional mode.
- (3) PLL reconfiguration is performed using ALTPLL\_RECONFIG controller. Hence it is not selected through the `reconfig_mode_sel [2..0]` port.
- (4) `reconfig_reset` will not restart the offset cancellation operation. Offset cancellation only occurs one time after power up and does not occur when subsequent `reconfig_reset` is asserted.

## Offset Cancellation Feature

The Cyclone IV GX devices provide an offset cancellation circuit per receiver channel to counter the offset variations due to process, voltage, and temperature (PVT). These variations create an offset in the analog circuit voltages, pushing them out of the expected range. In addition to reconfiguring the transceiver channel, the dynamic reconfiguration controller performs offset cancellation on all receiver channels connected to it on power up.

The **Offset cancellation for Receiver channels** option is automatically enabled in both the ALTGX and ALTGX\_RECONFIG MegaWizard Plug-In Managers for **Receiver and Transmitter** and **Receiver only** configurations. It is not available for **Transmitter only** configurations. For **Receiver and Transmitter** and **Receiver only** configurations, you must connect the necessary interface signals between the ALTGX\_RECONFIG and ALTGX (with receiver channels) instances.

Offset cancellation is automatically executed once every time the device is powered on. The control logic for offset cancellation is integrated into the dynamic reconfiguration controller. You must connect the ALTGX\_RECONFIG instance to the ALTGX instances (with receiver channels) in your design. You must connect the reconfig\_fromgxb, reconfig\_togxb, and necessary clock signals to both the ALTGX\_RECONFIG and ALTGX (with receiver channels) instances.

When the device powers up, the dynamic reconfiguration controller initiates offset cancellation on the receiver channel by disconnecting the receiver input pins from the receiver data path. Subsequently, the offset cancellation process goes through different states and culminates in the offset cancellation of the receiver buffer.

 Offset cancellation process only occurs one time after power up and does not occur when subsequent reconfig\_reset is asserted. If you assert reconfig\_reset after the offset cancellation process is completed, the offset cancellation process will not run again. If you assert reconfig\_reset upon power up; offset cancellation will not begin until reconfig\_reset is deasserted. If you assert reconfig\_reset after power up but before offset cancellation process is completed; offset cancellation will not complete and restart only when reconfig\_reset is deasserted.

Figure 3-2 shows the connection for offset cancellation mode.

**Figure 3-2. ALTGX and ALTGX\_RECONFIG Connection for the Offset Cancellation Process**

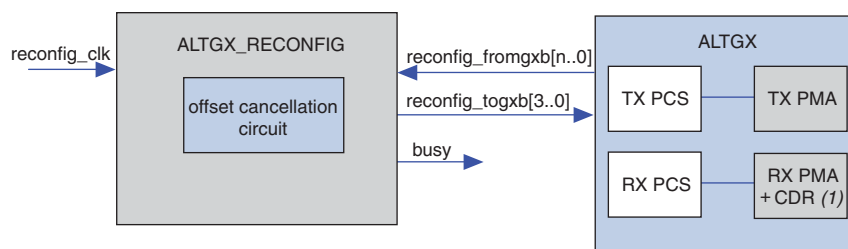

**Note to Figure 3-2:**

(1) This block is active during the offset cancellation process.

 The dynamic reconfiguration controller sends and receives data to the transceiver channel through the reconfig\_togxb and reconfig\_fromgxb signals.

 The gxb\_powerdown signal must not be asserted during the offset cancellation sequence.

Figure 3-3 shows the timing diagram for a offset cancellation process.

**Figure 3-3. Dynamic Reconfiguration Signals Transition during Offset Cancellation**

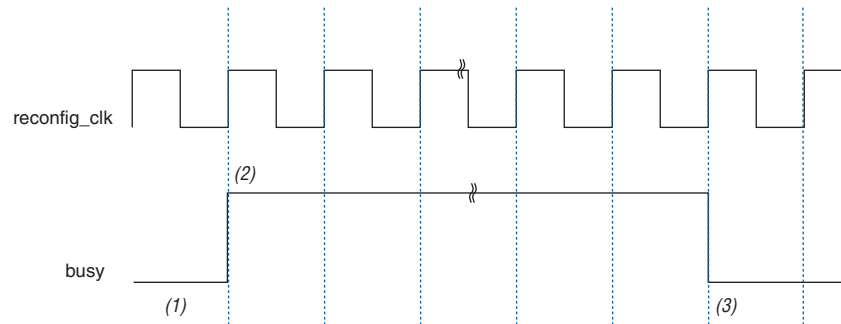

**Notes to Figure 3-3:**

- (1) After device power up, the `busy` signal remains low for the first `reconfig_clk` cycle.
- (2) The `busy` signal then gets asserted for the second `reconfig_clk` cycle, when the dynamic reconfiguration controller initiates the offset cancellation process.
- (3) The deassertion of the `busy` signal indicates the successful completion of the offset cancellation process.

### Functional Simulation of the Offset Cancellation Process

You must connect the `ALTGX_RECONFIG` instances to the `ALTGX` instances in your design for functional simulation. Functional simulation uses a reduced timing model of the dynamic reconfiguration controller. Therefore, the duration of the offset cancellation process is 16 `reconfig_clk` clock cycles for functional simulation only. The `gxb_powerdown` signal must not be asserted during the offset cancellation sequence (for functional simulation and silicon).

## Dynamic Reconfiguration Modes

When you enable the dynamic reconfiguration feature, you can reconfigure the following portions of each transceiver channel dynamically, without powering down the other transceiver channels or the FPGA fabric of the device:

- Analog (PMA) controls reconfiguration
- Channel reconfiguration
- PLL reconfiguration

Table 3-3 lists the supported dynamic reconfiguration modes for Cyclone IV GX devices.

**Table 3-3. Cyclone IV GX Supported Dynamic Reconfiguration Mode (Part 1 of 2)**

Dynamic Reconfiguration Supported Mode	Operational Mode			Quartus II Instances			.mif Requirements
	Transmitter Only	Receiver Only	Transmitter and Receiver Only	ALTGX	ALTGX_RECONFIG	ALTPLL_RECONFIG	
Offset Cancellation	—	✓	✓	✓	✓	—	—
Analog (PMA) Controls Reconfiguration	✓	✓	✓	✓	✓	—	—

**Table 3-3. Cyclone IV GX Supported Dynamic Reconfiguration Mode (Part 2 of 2)**

Dynamic Reconfiguration Supported Mode	Operational Mode			Quartus II Instances			.mif Requirements
	Transmitter Only	Receiver Only	Transmitter and Receiver Only	ALTGX	ALTGX_RECONFIG	ALTPLL_RECONFIG	
Channel Reconfiguration							
Channel Interface	✓	✓	✓	✓	✓	—	✓
Data Rate Division in Receiver Channel	—	✓	✓	✓	✓	—	✓
PLL Reconfiguration	✓	✓	✓	✓	—	✓	✓

The following modes are available for dynamically reconfiguring the Cyclone IV transceivers:

- “PMA Controls Reconfiguration Mode” on page 3-13
- “Transceiver Channel Reconfiguration Mode” on page 3-21
  - Channel interface (.mif based)
  - Data rate division in receiver channel (.mif based)

The following sections describe each of these modes in detail.

The following modes are unsupported for dynamic reconfiguration:

- Dynamically enable/disable PRBS or BIST
- Switch between a receiver-only channel and a transmitter-only channel
- Switch between a ×1 mode to a bonded ×4 mode

## PMA Controls Reconfiguration Mode

You can dynamically reconfigure the following PMA controls for all supported transceiver configurations channels as configured in the ALTGX instances:

- Pre-emphasis settings
- Equalization settings (channel reconfiguration mode does not support equalization settings)
- DC gain settings
- $V_{OD}$  settings

You can use the analog reconfiguration feature to dynamically reconfigure the transceivers channels setting in either the transmitter or the receivers in the PMA blocks. You can update the PMA controls on-the-fly based on the desired input. You can perform both read and write transaction separately for this analog reconfiguration mode.

There are three methods that you can use to dynamically reconfigure the PMA controls of a transceiver channel:

- “Method 1: Using `logical_channel_address` to Reconfigure Specific Transceiver Channels” on page 3-14
- “Method 2: Writing the Same Control Signals to Control All the Transceiver Channels” on page 3-16
- “Method 3: Writing Different Control Signals for all the Transceiver Channels at the Same Time” on page 3-19

### Method 1: Using `logical_channel_address` to Reconfigure Specific Transceiver Channels

Enable the `logical_channel_address` port by selecting the **Use 'logical\_channel\_address' port** option on the **Analog controls** tab. This method is applicable only for a design where the dynamic reconfiguration controller controls more than one channel.

You can additionally reconfigure either the receiver portion, transmitter portion, or both the receiver and transmitter portions of the transceiver channel by setting the corresponding value on the `rx_tx_duplex_sel` input port. For more information, refer to [Table 3-2 on page 3-4](#).

#### Connecting the PMA Control Ports

The selected PMA control ports remain fixed in width, regardless of the number of channels controlled by the `ALTGX_RECONFIG` instance:

- `tx_vodctrl` and `tx_vodctrl_out` are fixed to 3 bits
- `tx_preemp` and `tx_preemp_out` are fixed to 5 bits
- `rx_eqdcgain` and `rx_eqdcgain_out` are fixed to 2 bits
- `rx_eqctrl` and `rx_eqctrl_out` are fixed to 4 bits

#### Write Transaction

To complete a write transaction, perform the following steps:

1. Set the selected PMA control ports to the desired settings (for example, `tx_vodctrl = 3'b001`).
2. Set the `logical_channel_address` input port to the logical channel address of the transceiver channel whose PMA controls you want to reconfigure.
3. Set the `rx_tx_duplex_sel` port to `2'b10` so that only the transmit PMA controls are written to the transceiver channel.
4. Ensure that the busy signal is low before you start a write transaction.
5. Assert the `write_all` signal for one `reconfig_clk` clock cycle.

The busy output status signal is asserted high to indicate that the dynamic reconfiguration controller is busy writing the PMA control values. When the write transaction has completed, the busy signal goes low.

Figure 3-4 shows the write transaction waveform for Method 1.

**Figure 3-4. Write Transaction Waveform—Use 'logical\_channel\_address port' Option**

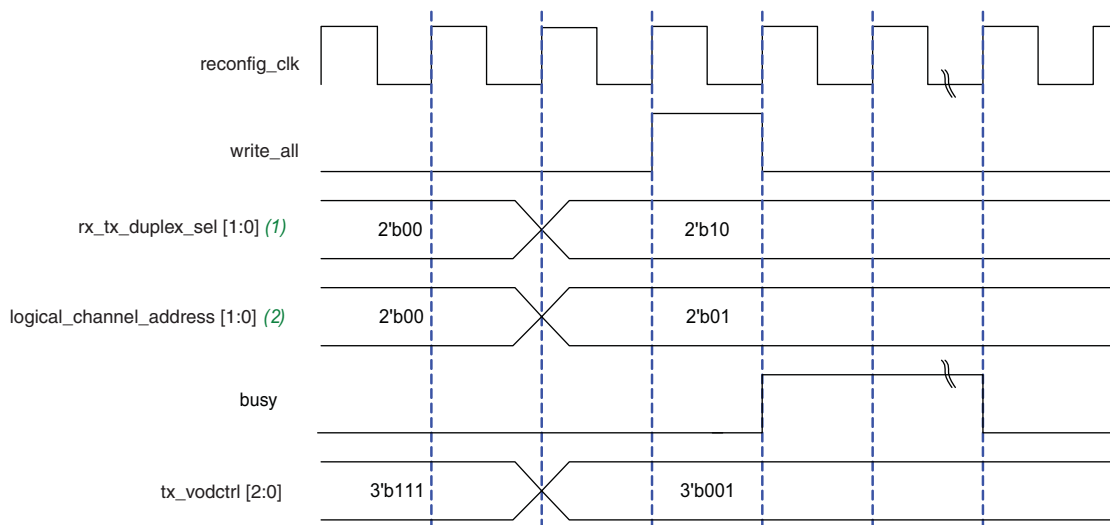

**Notes to Figure 3-4:**

- (1) In this waveform example, you are writing to only the transmitter portion of the channel.
- (2) In this waveform example, the number of channels connected to the dynamic reconfiguration controller is four. Therefore, the logical\_channel\_address port is 2 bits wide.

**Read Transaction**

For example, to read the existing  $V_{OD}$  values from the transmit  $V_{OD}$  control registers of the transmitter portion of a specific channel controlled by the ALTGX\_RECONFIG instance, perform the following steps:

1. Set the logical\_channel\_address input port to the logical channel address of the transceiver channel whose PMA controls you want to read (for example, tx\_vodctrl\_out).
2. Set the rx\_tx\_duplex\_sel port to 2'b10 so that only the transmit PMA controls are read from the transceiver channel.
3. Ensure that the busy signal is low before you start a read transaction.
4. Assert the read signal for one reconfig\_clk clock cycle. This initiates the read transaction.

The busy output status signal is asserted high to indicate that the dynamic reconfiguration controller is busy reading the PMA control values. When the read transaction has completed, the busy signal goes low. The data\_valid signal is asserted to indicate that the data available at the read control signal is valid.

Figure 3-5 shows the read transaction waveform for Method 1.

**Figure 3-5. Read Transaction Waveform—Use 'logical\_channel\_address port' Option**

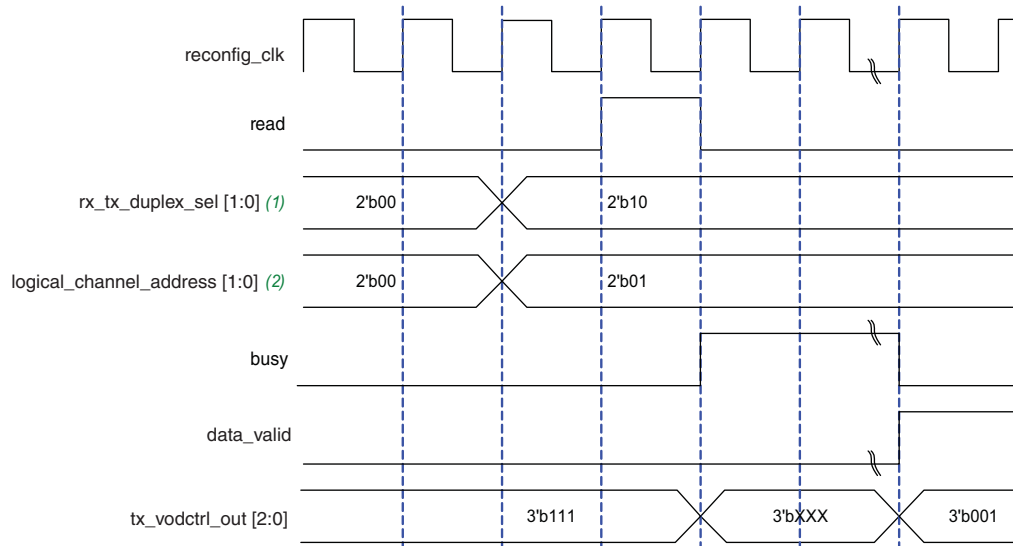

**Notes to Figure 3-5:**

- (1) In this waveform example, you want to read from only the transmitter portion of the channel.
- (2) In this waveform example, the number of channels connected to the dynamic reconfiguration controller is four. Therefore, the `logical_channel_address` port is 2 bits wide.



Simultaneous write and read transactions are not allowed.

### Method 2: Writing the Same Control Signals to Control All the Transceiver Channels

This method does not require the `logical_channel_address` port. The PMA controls of all the transceiver channels connected to the `ALTGX_RECONFIG` instance are reconfigured.

The **Use the same control signal for all the channels** option is available on the **Analog controls** tab of the `ALTGX_RECONFIG` MegaWizard Plug-In Manager. If you enable this option, the width of the PMA control ports are fixed as follows:

#### PMA Control Ports Used in a Write Transaction

- `tx_vodctrl` is fixed to 3 bits
- `tx_preemp` is fixed to 5 bits
- `rx_eqdcgain` is fixed to 2 bits
- `rx_eqctrl` is fixed to 4 bits

### PMA Control Ports Used in a Read Transaction

- tx\_vodctrl\_out is 3 bits per channel
- tx\_preemp\_out is 5 bits per channel
- rx\_eqdcgain\_out is 2 bits per channel
- rx\_eqctrl\_out is 4 bits per channel

For example, assume the number of channels controlled by the dynamic reconfiguration controller is two, tx\_vodctrl\_out is 6 bits wide.

### Write Transaction

The value you set at the selected PMA control ports is written to all the transceiver channels connected to the ALTGX\_RECONFIG instance.

For example, assume you have enabled tx\_vodctrl in the ALTGX\_RECONFIG MegaWizard Plug-In Manager to reconfigure the V<sub>OD</sub> of the transceiver channels. To complete a write transaction to reconfigure the V<sub>OD</sub>, perform the following steps:

1. Before you initiate a write transaction, set the selected PMA control ports to the desired settings (for example, tx\_vodctrl = 3'b001).
2. Set the rx\_tx\_duplex\_sel port to 2'b10 so that only the transmit PMA controls are written to the transceiver channel.
3. Ensure that the busy signal is low before you start a write transaction.
4. Assert the write\_all signal for one reconfig\_clk clock cycle. This initiates the write transaction.
5. The busy output status signal is asserted high to indicate that the dynamic reconfiguration controller is busy writing the PMA control values. When the write transaction has completed, the busy signal goes low.

Figure 3-6 shows the write transaction for Method 2.

**Figure 3-6. Write Transaction Waveform—Use the same control signal for all the channels Option**

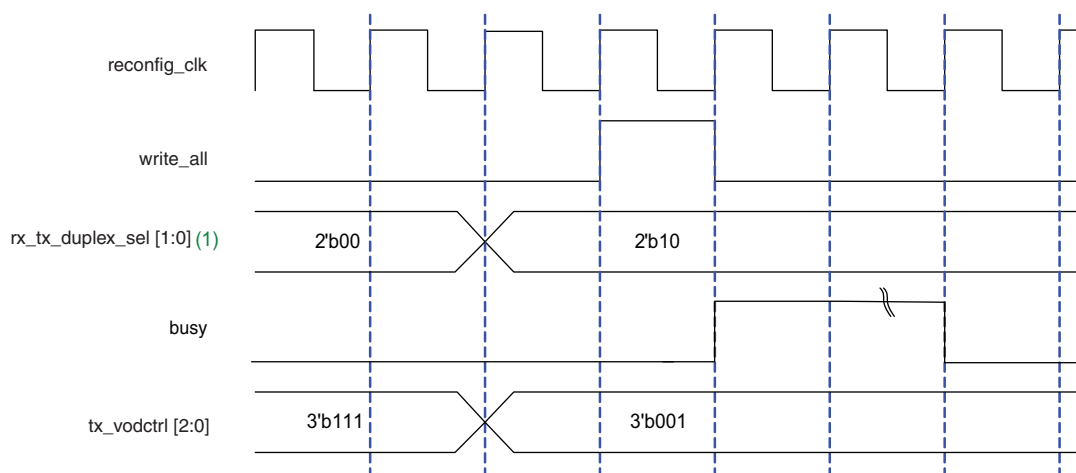

**Note to Figure 3-6:**

(1) In this waveform example, you want to write to only the transmitter portion of the channel.

### Read Transaction

If you want to read the existing values from a specific channel connected to the ALTGX\_RECONFIG instance, observe the corresponding byte positions of the PMA control output port after the read transaction is completed.

For example, if the number of channels controlled by the ALTGX\_RECONFIG is two, the tx\_vodctrl\_out is 6 bits wide. The tx\_vodctrl\_out[2:0] signal corresponds to channel 1 and the tx\_vodctrl\_out[5:3] signal corresponds to channel 2.

To complete a read transaction to the  $V_{OD}$  values of the second channel, perform the following steps:

1. Before you initiate a read transaction, set the rx\_tx\_duplex\_sel port to **2'b10** so that only the transmit PMA controls are read from the transceiver channel.
2. Ensure that the busy signal is low before you start a read transaction.
3. Assert the read signal for one reconfig\_clk clock cycle. This initiates the read transaction.
4. The busy output status signal is asserted high to indicate that the dynamic reconfiguration controller is busy reading the PMA control settings.
5. When the read transaction has completed, the busy signal goes low. The data\_valid signal is asserted, indicating that the data available at the read control signal is valid.
6. To read the current  $V_{OD}$  values in channel 2, observe the values in tx\_vodctrl\_out[5:3].

In the waveform example shown in [Figure 3-7](#), the transmit  $V_{OD}$  settings written in channels 1 and 2 prior to the read transaction are 3'b001 and 3'b010, respectively.

**Figure 3-7. Read Transaction Waveform—Use the same control signal for all the channels Option Enabled**

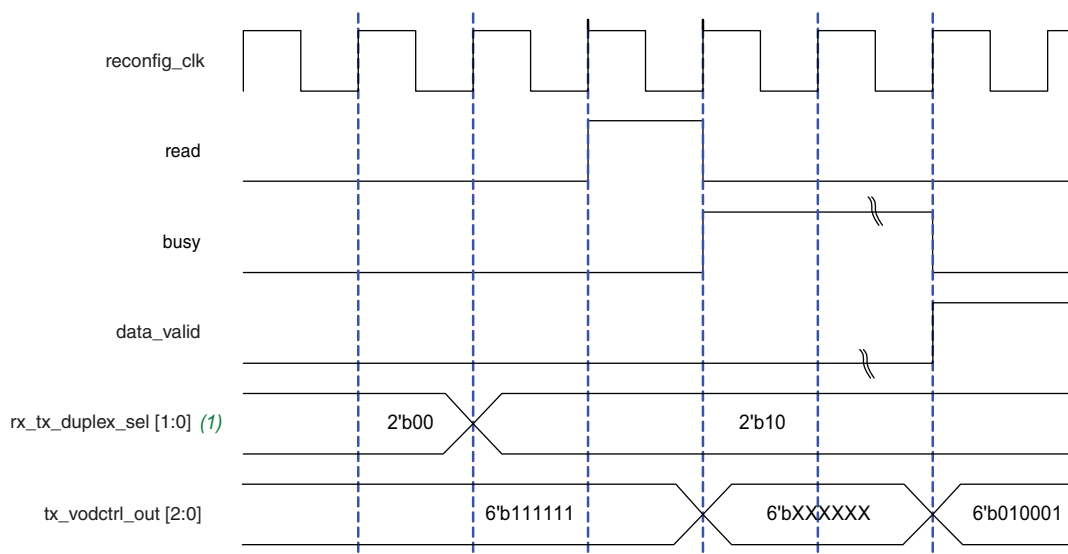

#### Note to [Figure 3-7](#):

(1) In this waveform example, you want to read from only the transmitter portion of all the channels.



Simultaneous write and read transactions are not allowed.

### Method 3: Writing Different Control Signals for all the Transceiver Channels at the Same Time

If you disable the **Use the same control signal for all the channels** option, the PMA control ports for a write transaction are separate for each channel. If you disable this option, the width of the PMA control ports are fixed as follows:

#### PMA Control Ports Used in a Write Transaction

- `tx_vodctrl` is 3 bits per channel
- `tx_preemp` are 5 bits per channel
- `rx_eqdcgain` is 2 bits per channel
- `rx_eqctrl` is 4 bits per channel

For example, if you have two channels, the `tx_vodctrl` is 6 bits wide (`tx_vodctrl [2:0]` corresponds to channel 1 and `tx_vodctrl [5:3]` corresponds to channel 2).

#### PMA Control Ports Used in a Read Transaction

The width of the PMA control ports for a read transaction are always separate for each channel as explained in [“Method 2: Writing the Same Control Signals to Control All the Transceiver Channels”](#) on page 3-16.

#### Write Transaction

Because the PMA controls of all the channels are written, if you want to reconfigure a specific channel connected to the `ALTGX_RECONFIG` instance, set the new value at the corresponding PMA control port of the channel under consideration and retain the previously stored values in the other active channels with a read transaction prior to this write transaction.

For example, if the number of channels controlled by the `ALTGX_RECONFIG` instance is two, the `tx_vodctrl` signal in this case would be 6 bits wide. The `tx_vodctrl [2:0]` signal corresponds to channel 1 and the `tx_vodctrl [5:3]` signal corresponds to channel 2.

- To dynamically reconfigure the PMA controls of only channel 2 with a new value, first perform a read transaction to retrieve the existing PMA control values from `tx_vodctrl_out [5:0]`. Use the `tx_vodctrl_out [2:0]` value for `tx_vodctrl [2:0]` to write in channel 1. By doing so, channel 1 is overwritten with the same value.
- Perform a write transaction. This ensures that the new values are written only to channel 2 while channel 1 remains unchanged.

Figure 3-8 shows a write transaction waveform with the **Use the same control signal for all the channels** option disabled.

**Figure 3-8. Write Transaction Waveform—Use the same control signal for all the channels Option Disabled**

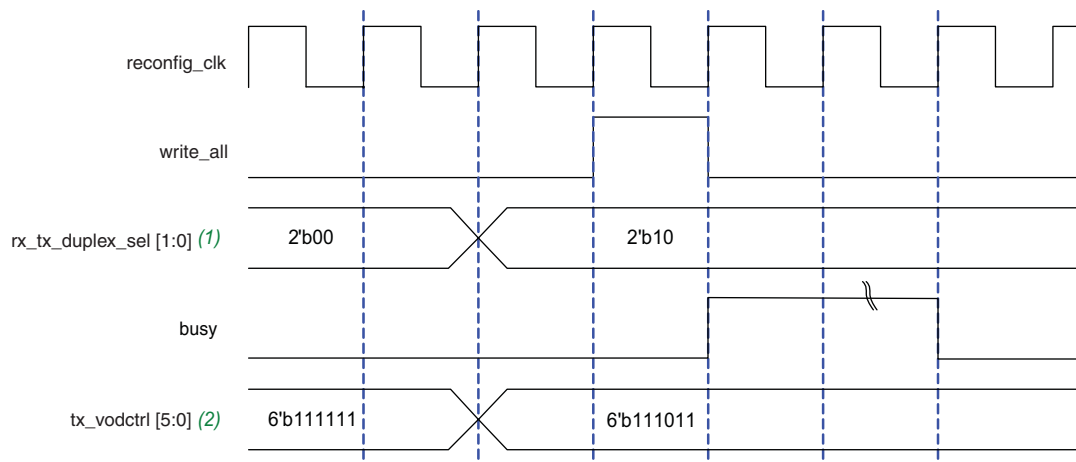

**Notes to Figure 3-8:**

- (1) In this waveform example, you want to write to only the transmitter portion of the channel.
- (2) In this waveform example, the number of channels controlled by the dynamic reconfiguration controller (the ALTGX\_RECONFIG instance) is two and that the `tx_vodctrl` control port is enabled.



Simultaneous write and read transactions are not allowed.

### Read Transaction

The read transaction in Method 3 is identical to that in Method 2. Refer to “[Read Transaction](#)” on page 3-18.



This is the slowest method. You have to write all the PMA settings for all channels even if you may only be changing one parameter on the channel. Altera recommends using the `logical_channel_address` method for time-critical applications.

For each method, you can additionally reconfigure the PMA setting of both transmitter and receiver portion, transmitter portion only, or receiver portion only of the transceiver channel. For more information, refer to “[Dynamic Reconfiguration Controller Port List](#)” on page 3-4. You can enable the `rx_tx_duplex_sel` port by selecting the **Use 'rx\_tx\_duplex\_sel' port to enable RX only, TX only or duplex reconfiguration** option on the **Error checks** tab of the ALTGX\_RECONFIG MegaWizard Plug-In Manager.

Figure 3-9 shows the ALTGX\_RECONFIG connection to the ALTGX instances when set in analog reconfiguration mode. For the port information, refer to the “[Dynamic Reconfiguration Controller Port List](#)” on page 3-4.

Figure 3-9 shows the connection for PMA reconfiguration mode.

**Figure 3-9. ALTGX and ALTGX\_RECONFIG Connection for PMA Reconfiguration Mode**

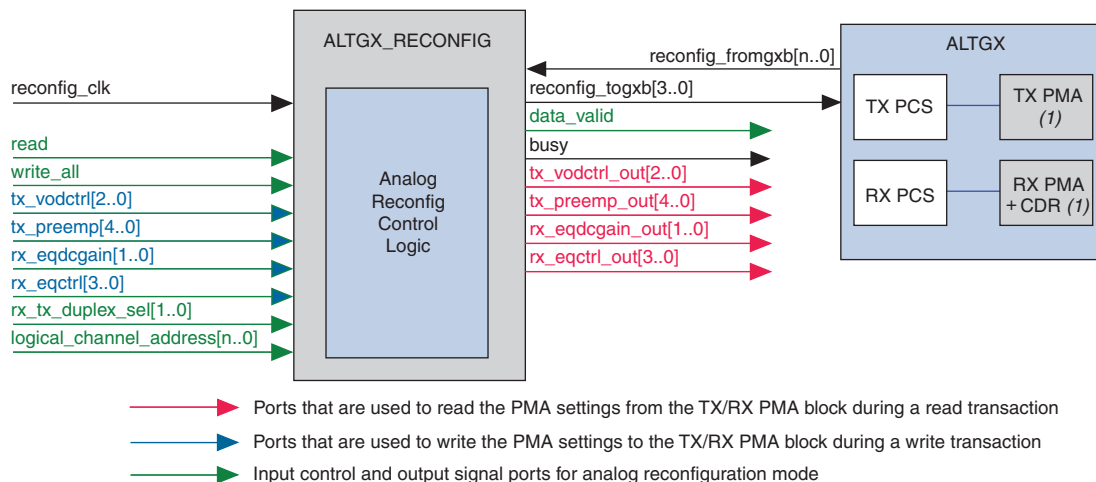

**Note to Figure 3-9:**

(1) This block can be reconfigured in PMA reconfiguration mode.

## Transceiver Channel Reconfiguration Mode

You can dynamically reconfigure the transceiver channel from an existing functional mode to a different functional mode by selecting the **Channel Reconfiguration** option in ALTGX and ALTGX\_RECONFIG MegaWizards. The blocks that are reconfigured by channel reconfiguration mode are the PCS and RX PMA blocks of a transceiver channel.



For more information about reconfiguring the RX PMA blocks of the transceiver channel using channel reconfiguration mode, you can refer to “[Data Rate Reconfiguration Mode Using RX Local Divider](#)” on page 3-26.

In channel reconfiguration, only a write transaction can occur; no read transactions are allowed. You can optionally choose to trigger write\_all once by selecting the continuous write operation in the ALTGX\_RECONFIG MegaWizard Plug-In Manager. The Quartus II software then continuously writes all the words required for reconfiguration.

For channel reconfiguration, .mif files are required to dynamically reconfigure the transceivers channels in channel reconfiguration modes. The .mif carries the reconfiguration information that will be used to reconfigure the transceivers channel dynamically on-the-fly. The .mif contents is generated automatically when you select the **Generate GXB Reconfig MIF** option in the Quartus II software setting. For different .mif settings, you need to later reconfigure and recompile the ALTGX MegaWizard to generate the .mif based on the required reconfiguration settings.

The dynamic reconfiguration controller can optionally perform a continuous write operation or a regular write operation of the .mif contents in terms of word size (16-bit data) to the transceivers channel that is selected for reconfiguration.

The following are the channel reconfiguration mode options:

- Channel interface reconfiguration
- Data rate division at receiver channel

### Channel Interface Reconfiguration Mode

Enable this option if the reconfiguration of the transceiver channel involves the following changes:

- The reconfigured channel has a changed FPGA fabric-Transceiver channel interface data width
- The reconfigured channel has changed input control signals and output status signals
- The reconfigured channel has enabled and disabled the static PCS blocks of the transceiver channel

The following are the new input signals available when you enable this option:

- `tx_datainfull`—the width of this input signal depends on the number of channels you set up in the ALTGX MegaWizard Plug-In Manager. It is 22 bits wide per channel. This signal is available only for **Transmitter only** and **Receiver and Transmitter** configurations. This port replaces the existing `tx_datain` port.
- `rx_dataoutfull`—the width of this output signal depends on the number of channels you set up in the ALTGX MegaWizard Plug-In Manager. It is 32 bits wide per channel. This signal is available only for **Receiver only** and **Receiver and Transmitter** configurations. This port replaces the existing `rx_dataout` port.

The Quartus II software has legality checks for the connectivity of `tx_datainfull` and `rx_dataoutfull` and the various control and status signals you enable in the **Clocking/Interface** screen. For example, the Quartus II software allows you to select and connect the `pipestatus` and `powerdn` signals. It assumes that you are planning to switch to and from PCI Express (PIPE) functional mode.

Table 3-4 describes the tx\_datainfull[21..0] FPGA fabric-transceiver channel interface signals.

**Table 3-4. tx\_datainfull[21..0] FPGA Fabric-Transceiver Channel Interface Signal Descriptions <sup>(1)</sup>**

FPGA Fabric-Transceiver Channel Interface Description	Transmit Signal Description (Based on Cyclone IV GX Supported FPGA Fabric-Transceiver Channel Interface Widths)
8-bit FPGA fabric-Transceiver Channel Interface	tx_datainfull[7:0]: 8-bit data (tx_datain)
	<b>The following signals are used only in 8B/10B modes:</b>
	tx_datainfull[8]: Control bit (tx_ctrlnable)
	tx_datainfull[9] Transmitter force disparity Compliance (PCI Express [PIPE]) (tx_forcedisp) in all modes except PCI Express (PIPE) functional mode. For PCI Express (PIPE) functional mode, (tx_forcedispcompliance) is used.
	<ul style="list-style-type: none"> <li>■ For non-PIPE: tx_datainfull[10]: Forced disparity value (tx_dispval)</li> <li>■ For PCIe: tx_datainfull[10]: Forced electrical idle (tx_forceelecidle)</li> </ul>
10-bit FPGA fabric-Transceiver Channel Interface	tx_datainfull[9:0]: 10-bit data (tx_datain)
16-bit FPGA fabric-Transceiver Channel Interface with PCS-PMA set to 8/10 bits	Two 8-bit Data (tx_datain) tx_datainfull[7:0] - tx_datain (LSByte) and tx_datainfull[18:11] - tx_datain (MSByte)
	<b>The following signals are used only in 8B/10B modes:</b>
	tx_datainfull[8] - tx_ctrlnable (LSB) and tx_datainfull[19] - tx_ctrlnable (MSB)
	Force Disparity Enable <ul style="list-style-type: none"> <li>■ For non-PIPE: tx_datainfull[9] - tx_forcedisp (LSB) and tx_datainfull[20] - tx_forcedisp (MSB)</li> <li>■ For PCIe: tx_datainfull[9] - tx_forcedispcompliance and tx_datainfull[20] - 0</li> </ul>
	Force Disparity Value <ul style="list-style-type: none"> <li>■ For non-PIPE: tx_datainfull[10] - tx_dispval (LSB) and tx_datainfull[21] - tx_dispval (MSB)</li> <li>■ For PCIe: tx_datainfull[10] - tx_forceelecidle and tx_datainfull[21] - tx_forceelecidle</li> </ul>
20-bit FPGA fabric-Transceiver Channel Interface with PCS-PMA set to 10 bits	Two 10-bit Data (tx_datain) tx_datainfull[9:0] - tx_datain (LSByte) and tx_datainfull[20:11] - tx_datain (MSByte)

**Note to Table 3-4:**

(1) For all transceiver-related ports, refer to the “Transceiver Port Lists” section in the *Cyclone IV GX Transceiver Architecture* chapter.

Table 3-5 describes the rx\_dataoutfull[31..0] FPGA fabric-Transceiver channel interface signals.

**Table 3-5. rx\_dataoutfull[31..0] FPGA Fabric-Transceiver Channel Interface Signal Descriptions (Part 1 of 3)**

FPGA Fabric-Transceiver Channel Interface Description	Receive Signal Description (Based on Cyclone IV GX Supported FPGA Fabric-Transceiver Channel Interface Widths)
8-bit FPGA fabric-Transceiver Channel Interface	<b>The following signals are used in 8-bit 8B/10B modes:</b>
	rx_dataoutfull[7:0]: 8-bit decoded data (rx_dataout)
	rx_dataoutfull[8]: Control bit (rx_ctrlldetect)
	rx_dataoutfull[9]: Code violation status signal (rx_errdetect)
	rx_dataoutfull[10]: rx_syncstatus
	rx_dataoutfull[11]: Disparity error status signal (rx_disperr)
	rx_dataoutfull[12]: Pattern detect status signal (rx_patterndetect)
	rx_dataoutfull[13]: Rate Match FIFO deletion status indicator (rx_rmfifodatadeleted) in non-PCI Express (PIPE) functional modes.
	rx_dataoutfull[14]: Rate Match FIFO insertion status indicator (rx_rmfifodatainserted) in non-PCI Express (PIPE) functional modes.
	rx_dataoutfull[14:13]: PCI Express (PIPE) functional mode (rx_pipestatus)
10-bit FPGA fabric-Transceiver Channel Interface	rx_dataoutfull[9:0]: 10-bit un-encoded data (rx_dataout)
	rx_dataoutfull[10]: rx_syncstatus
	rx_dataoutfull[11]: 8B/10B disparity error indicator (rx_disperr)
	rx_dataoutfull[12]: rx_patterndetect
	rx_dataoutfull[13]: Rate Match FIFO deletion status indicator (rx_rmfifodatadeleted) in non-PCI Express (PIPE) functional modes
	rx_dataoutfull[14]: Rate Match FIFO insertion status indicator (rx_rmfifodatainserted) in non-PCI Express (PIPE) functional modes
	rx_dataoutfull[15]: 8B/10B running disparity indicator (rx_runningdisp)

**Table 3-5. rx\_dataoutfull[31..0] FPGA Fabric-Transceiver Channel Interface Signal Descriptions (Part 2 of 3)**

FPGA Fabric-Transceiver Channel Interface Description	Receive Signal Description (Based on Cyclone IV GX Supported FPGA Fabric-Transceiver Channel Interface Widths)
16-bit FPGA fabric-Transceiver Channel Interface with PCS-PMA set to 8/10 bits	Two 8-bit unencoded Data (rx_dataout) rx_dataoutfull[7:0] - rx_dataout (LSByte) and rx_dataoutfull[23:16] - rx_dataout (MSByte)
	<b>The following signals are used in 16-bit 8B/10B modes:</b>
	Two Control Bits rx_dataoutfull[8] - rx_ctrldetect (LSB) and rx_dataoutfull[24] - rx_ctrldetect (MSB)
	Two Receiver Error Detect Bits rx_dataoutfull[9] - rx_errdetect (LSB) and rx_dataoutfull[25] - rx_errdetect (MSB)
	Two Receiver Sync Status Bits rx_dataoutfull [10] - rx_syncstatus (LSB) and rx_dataoutfull[26] - rx_syncstatus (MSB)
	Two Receiver Disparity Error Bits rx_dataoutfull [11] - rx_disperr (LSB) and rx_dataoutfull[27] - rx_disperr (MSB)
	Two Receiver Pattern Detect Bits rx_dataoutfull[12] - rx_patterndetect (LSB) and rx_dataoutfull[28] - rx_patterndetect (MSB)
	rx_dataoutfull[13] and rx_dataoutfull[29]: Rate Match FIFO deletion status indicator (rx_rmfiwodatadeleted) in non-PCI Express (PIPE) functional modes
	rx_dataoutfull[14] and rx_dataoutfull[30]: Rate Match FIFO insertion status indicator (rx_rmfiwodatainserted) in non-PCI Express (PIPE) functional modes
	Two 2-bit PCI Express (PIPE) Functional Mode Status Bits rx_dataoutfull[14:13] - rx_pipestatus (LSB) and rx_dataoutfull[30:29] - rx_pipestatus (MSB)
	rx_dataoutfull[15] and rx_dataoutfull[31]: 8B/10B running disparity indicator (rx_runningdisp)

**Table 3-5. rx\_dataoutfull[31..0] FPGA Fabric-Transceiver Channel Interface Signal Descriptions (Part 3 of 3)**

FPGA Fabric-Transceiver Channel Interface Description	Receive Signal Description (Based on Cyclone IV GX Supported FPGA Fabric-Transceiver Channel Interface Widths)
20-bit FPGA fabric-Transceiver Channel Interface with PCS-PMA set to 10 bits	Two 10-bit Data (rx_dataout) rx_dataoutfull[9:0] - rx_dataout (LSByte) and rx_dataoutfull[25:16] - rx_dataout (MSByte)
	Two Receiver Sync Status Bits rx_dataoutfull[10] - rx_syncstatus (LSB) and rx_dataoutfull[26] - rx_syncstatus (MSB)
	rx_dataoutfull[11] and rx_dataoutfull[27]: 8B/10B disparity error indicator (rx_disperr)
	Two Receiver Pattern Detect Bits rx_dataoutfull[12] - rx_patterndetect (LSB) and rx_dataoutfull[28] - rx_patterndetect (MSB)
	rx_dataoutfull[13] and rx_dataoutfull[29]: Rate Match FIFO deletion status indicator (rx_rmfifodatadeleted) in non-PCI Express (PIPE) functional modes
	rx_dataoutfull[14] and rx_dataoutfull[30]: Rate Match FIFO insertion status indicator (rx_rmfifodatainserted) in non-PCI Express (PIPE) functional modes
	rx_dataoutfull[15] and rx_dataoutfull[31]: 8B/10B running disparity indicator (rx_runningdisp)

### Data Rate Reconfiguration Mode Using RX Local Divider

The RX local divider resides in the RX PMA block for every channels. This is a hardware feature where a /2 divider is available in each of the receiver channel for the supported device. You can use this RX local divider to reconfigure the data rate at the receiver channel. This can be used for protocols such as SDI that has data rates in divisions of 2.

By using this RX local divider, you can support two different data rates without using additional transceiver PLLs. This dynamic reconfiguration mode is available only for the receiver and not applicable to the transmitter. This reconfiguration mode using the RX local divider (/2) is only supported and available in EP4CGX30 (F484 package), EP4CGX50, and EP4CGX75 devices.



For more information about this RX local divider, refer to the *Cyclone IV GX Transceiver Architecture* chapter.

## Control and Status Signals for Channel Reconfiguration

The various control and status signals involved in the Channel Reconfiguration mode are as follows. Refer to “Dynamic Reconfiguration Controller Port List” on page 3-4 for the descriptions of the control and status signals.

The following are the input control signals:

- logical\_channel\_address[n..0]
- reset\_reconfig\_address
- reconfig\_reset
- reconfig\_mode\_sel[2..0]
- write\_all

The following are output status signals:

- reconfig\_address\_en
- reconfig\_address\_out[5..0]
- channel\_reconfig\_done
- busy

The ALTGX\_RECONFIG connection to the ALTGX instances when set in channel reconfiguration mode are as follows. For the port information, refer to “Dynamic Reconfiguration Controller Port List” on page 3-4.

Figure 3-10 shows the connection for channel reconfiguration mode.

**Figure 3-10. ALTGX and ALTGX\_RECONFIG Connection for Channel Reconfiguration Mode**

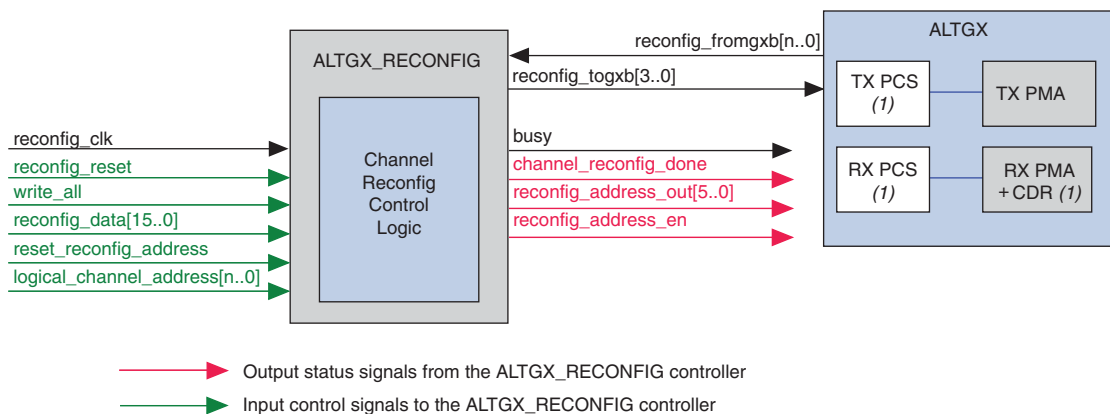

**Note to Figure 3-10:**

(1) This block can be reconfigured in channel reconfiguration mode.

### Clocking/Interface Options

The following describes the **Clocking/Interface** options available in Cyclone IV GX devices. The core clocking setup describes the transceiver core clocks that are the write and read clocks of the Transmit Phase Compensation FIFO and the Receive Phase Compensation FIFO, respectively. Core clocking is classified as transmitter core clocking and receiver core clocking.

Table 3-6 lists the supported clocking interface settings for channel reconfiguration mode in Cyclone IV GX devices.

**Table 3-6. Dynamic Reconfiguration Clocking Interface Settings in Channel Reconfiguration Mode**

ALTGX Setting	Description
Dynamic Reconfiguration Channel Internal and Interface Settings	
How should the receivers be clocked?	Select one of the available options: <ul style="list-style-type: none"> <li>■ <b>Share a single transmitter core clock between receivers</b></li> <li>■ <b>Use the respective channel transmitter core clocks</b></li> <li>■ <b>Use the respective channel receiver core clocks</b></li> </ul>
How should the transmitters be clocked?	Select one of the available options: <ul style="list-style-type: none"> <li>■ <b>Share a single transmitter core clock between transmitters</b></li> <li>■ <b>Use the respective channel transmitter core clocks</b></li> </ul>

Transmitter core clocking refers to the clock that is used to write the parallel data from the FPGA fabric into the Transmit Phase Compensation FIFO. You can use one of the following clocks to write into the Transmit Phase Compensation FIFO:

- **tx\_coreclk**—you can use a clock of the same frequency as tx\_clkout from the FPGA fabric to provide the write clock to the Transmit Phase Compensation FIFO. If you use tx\_coreclk, it overrides the tx\_clkout options in the ALTGX MegaWizard Plug-In Manager.
- **tx\_clkout**—the Quartus II software automatically routes tx\_clkout to the FPGA fabric and back into the Transmit Phase Compensation FIFO.

### Option 1: Share a Single Transmitter Core Clock Between Transmitters

- Enable this option if you want tx\_clkout of the first channel (channel 0) of the transceiver block to provide the write clock to the Transmitter Phase Compensation FIFOs of the remaining channels in the transceiver block.
- This option is typically enabled when all the channels of a transceiver block have the same functional mode and data rate and are reconfigured to the identical functional mode and data rate.

Figure 3-11 shows the sharing of channel 0's tx\_clkout between all four regular channels of a transceiver block.

Figure 3-11. Option 1 for Transmitter Core Clocking (Channel Reconfiguration Mode)

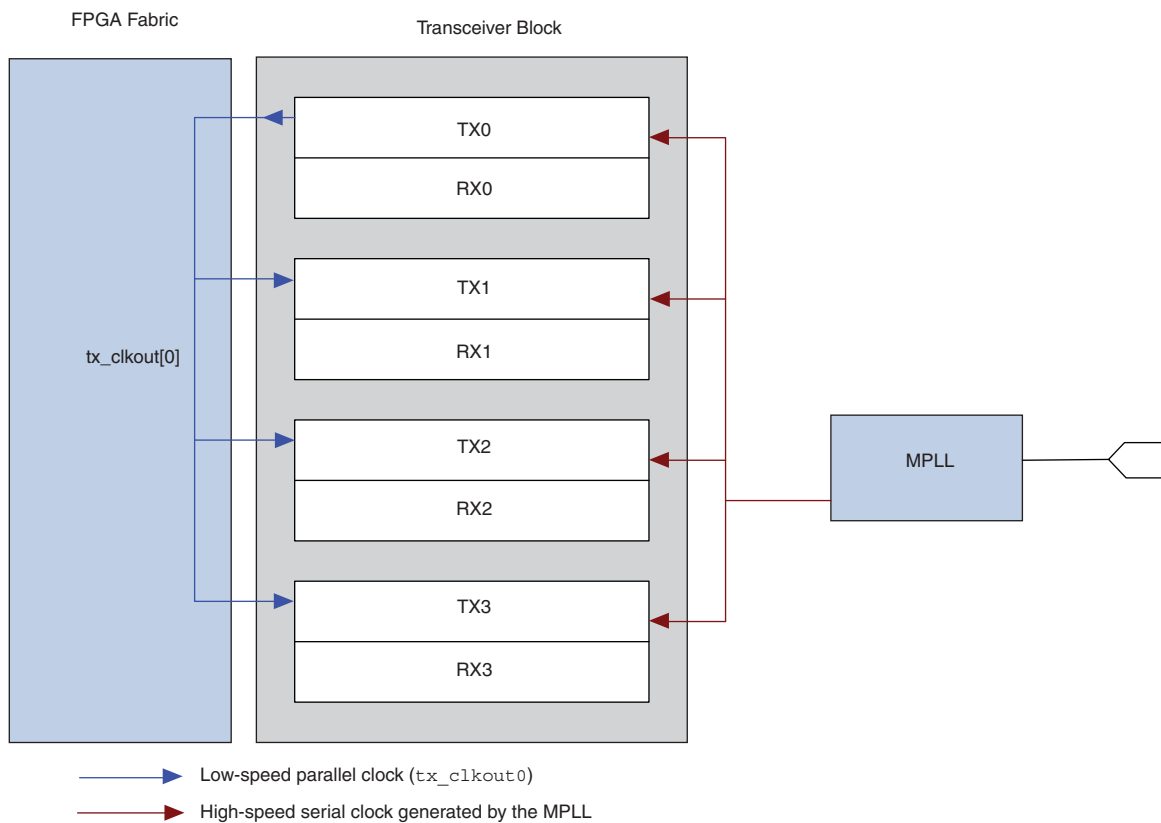

**Option 2: Use the Respective Channel Transmitter Core Clocks**

- Enable this option if you want the individual transmitter channel `tx_clkout` signals to provide the write clock to their respective Transmit Phase Compensation FIFOs.
- This option is typically enabled when each transceiver channel is reconfigured to a different functional mode using channel reconfiguration.

Figure 3-12 shows how each transmitter channel's `tx_clkout` signal provides a clock to the Transmit Phase Compensation FIFOs of the respective transceiver channels.

**Figure 3-12. Option 2 for Transmitter Core Clocking (Channel Reconfiguration Mode)**

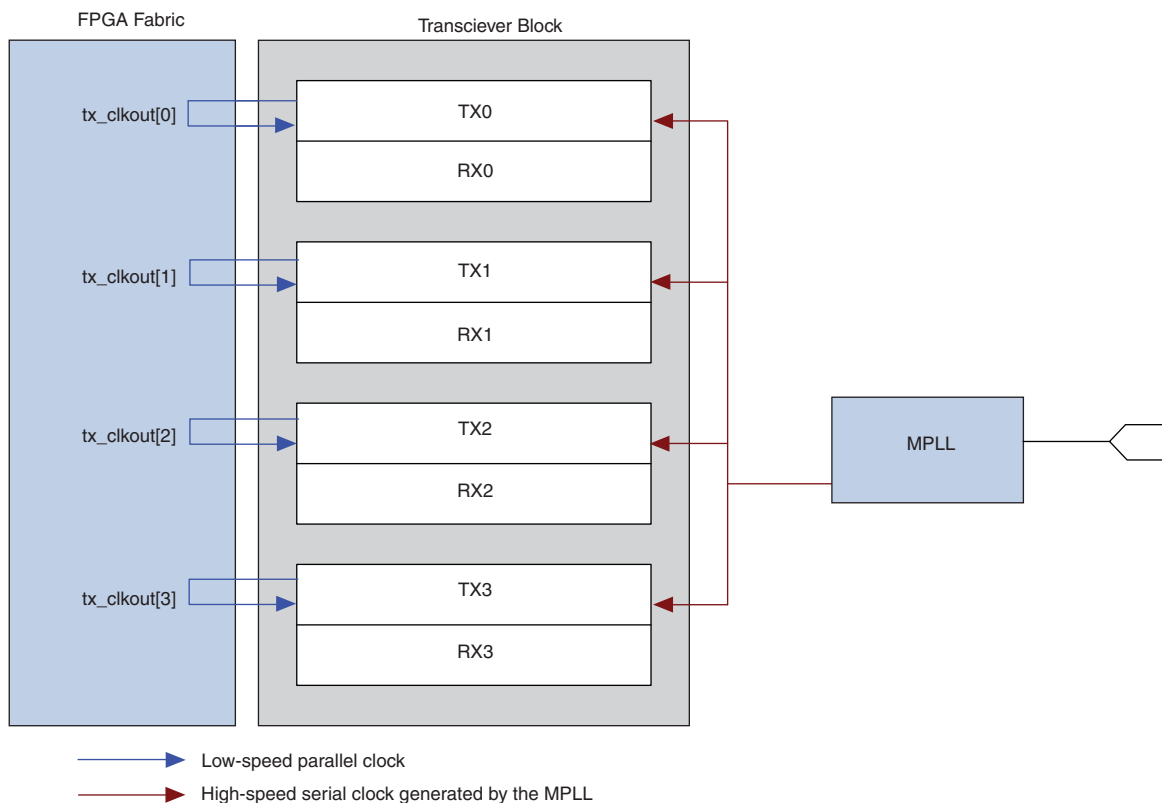

Receiver core clocking refers to the clock that is used to read the parallel data from the Receiver Phase Compensation FIFO into the FPGA fabric. You can use one of the following clocks to read from the Receive Phase Compensation FIFO:

- `rx_coreclk`—you can use a clock of the same frequency as `rx_clkout` from the FPGA fabric to provide the read clock to the Receive Phase Compensation FIFO. If you use `rx_coreclk`, it overrides the `rx_clkout` options in the ALTGX MegaWizard Plug-In Manager.
- `rx_clkout`—the Quartus II software automatically routes `rx_clkout` to the FPGA fabric and back into the Receive Phase Compensation FIFO.

### Option 1: Share a Single Transmitter Core Clock Between Receivers

- Enable this option if you want tx\_clkout of the first channel (channel 0) of the transceiver block to provide the read clock to the Receive Phase Compensation FIFOs of the remaining receiver channels in the transceiver block.
- This option is typically enabled when all the channels of a transceiver block are in a Basic or Protocol configuration with rate matching enabled and are reconfigured to another Basic or Protocol configuration with rate matching enabled.

Figure 3–13 shows the sharing of channel 0's tx\_clkout between all four channels of a transceiver block.

**Figure 3–13. Option 1 for Receiver Core Clocking (Channel Reconfiguration Mode)**

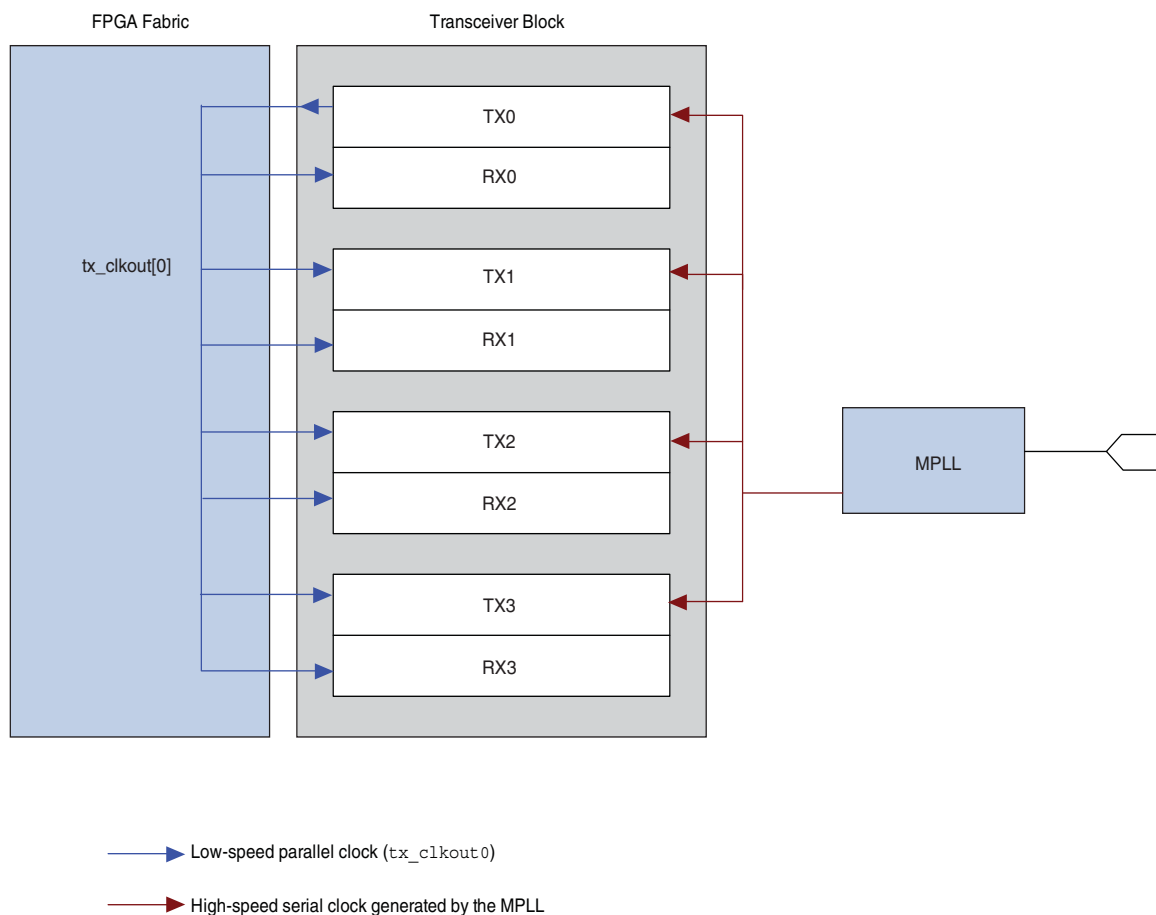

**Option 2: Use the Respective Channel Transmitter Core Clocks**

- Enable this option if you want the individual transmitter channel's `tx_clkout` signal to provide the read clock to its respective Receive Phase Compensation FIFO.
- This option is typically enabled when all the transceiver channels have rate matching enabled with different data rates and are reconfigured to another Basic or Protocol functional mode with rate matching enabled.

Figure 3-14 shows the respective `tx_clkout` of each channel clocking the respective channels of a transceiver block.

**Figure 3-14. Option 2 for Receiver Core Clocking (Channel Reconfiguration Mode)**

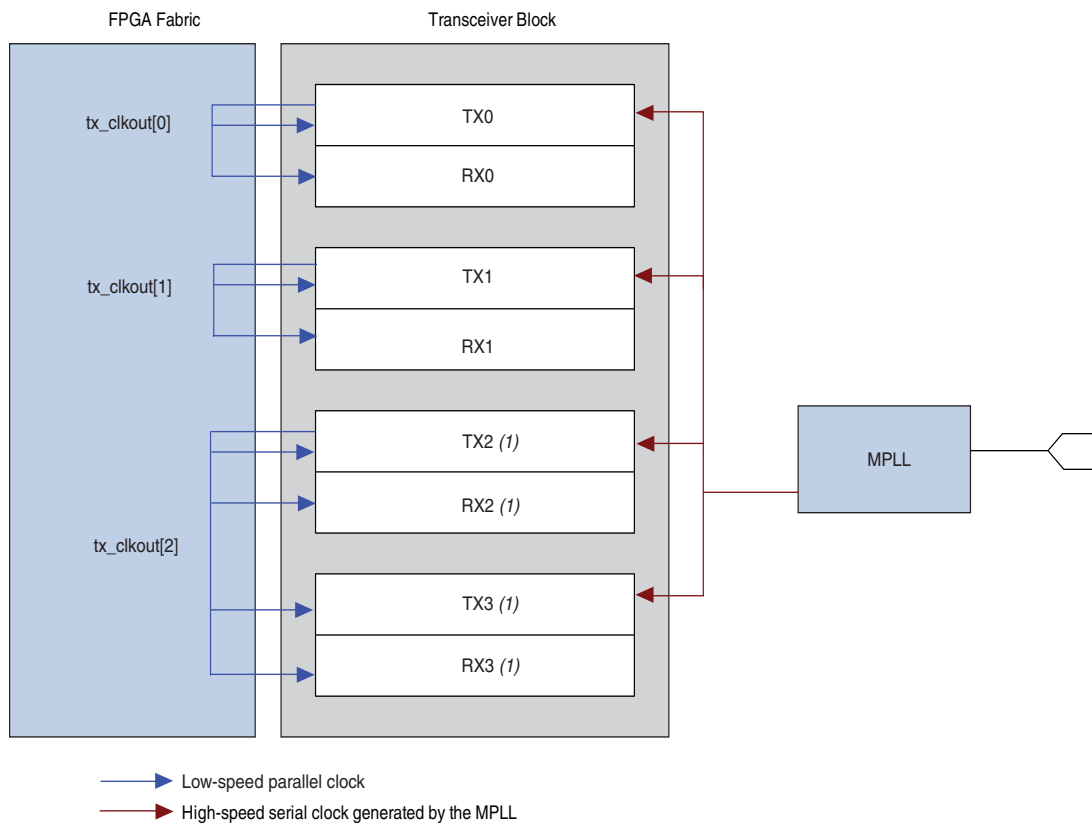
**Note to Figure 3-14:**

- (1) Assuming channel 2 and 3 are running at the same data rate with rate matcher enabled and are reconfigured to another Basic or Protocol functional mode with rate matching enabled.

### Option 3: Use the Respective Channel Receiver Core Clocks

- Enable this option if you want the individual channel's rx\_clkout signal to provide the read clock to its respective Receive Phase Compensation FIFO.
- This option is typically enabled when the channel is reconfigured from a Basic or Protocol configuration with or without rate matching to another Basic or Protocol configuration with or without rate matching.

Figure 3-15 shows the respective rx\_clkout of each channel clocking the respective receiver channels of a transceiver block.

**Figure 3-15. Option 3 for Receiver Core Clocking (Channel Reconfiguration Mode)**

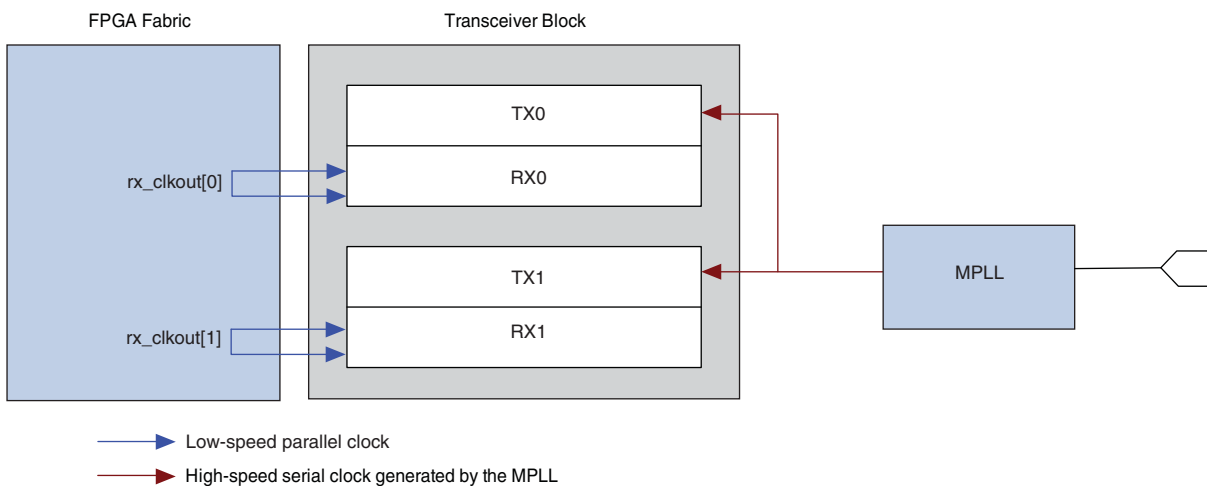

## PLL Reconfiguration Mode

Cyclone IV GX device support the PLL reconfiguration support through the ALTPLL\_RECONFIG MegaWizard. You can use this mode to reconfigure the multipurpose PLL or general purpose PLL used to clock the transceiver channel without affecting the remaining blocks of the channel. When you reconfigure the multipurpose PLL or general purpose PLL of a transceiver block to run at a different data rate, all the transceiver channels listening to this multipurpose PLL or general purpose PLL also get reconfigured to the new data rate. Channel settings are not affected. When you reconfigure the multipurpose PLL or general purpose PLL to support a different data rate, you must ensure that the functional mode of the transceiver channel supports the reconfigured data rate.

The PLL reconfiguration mode can be enabled by selecting the **Enable PLL Reconfiguration** option in the ALTGX MegaWizard under **Reconfiguration Setting** tab. For multipurpose PLL or general purpose PLL reconfiguration, **.mif** files are required to dynamically reconfigure the PLL setting in order to change the output frequency of the transceiver PLL to support different data rates.

The `.mif` files carries the reconfiguration information that will be used to reconfigure the multipurpose PLL or general purpose PLL dynamically. The `.mif` contents is generated automatically when you select the **Enable PLL Reconfiguration** option in the **Reconfiguration Setting** in ALTGX instances. The `.mif` files will be generated based on the data rate and input reference clock setting in the ALTGX MegaWizard. You must use the external ROM and feed its content to the ALTPLL\_RECONFIG megafunction to reconfigure the multipurpose PLL setting.

For more information about instantiating the ALTPLL\_Reconfig, refer to the [AN 609: Implementing Dynamic Reconfiguration in Cyclone IV GX Devices](#).

Figure 3-16 shows the connection for PLL reconfiguration mode.

**Figure 3-16. ALTGX and ALTPLL\_RECONFIG Connection for PLL Reconfiguration Mode**

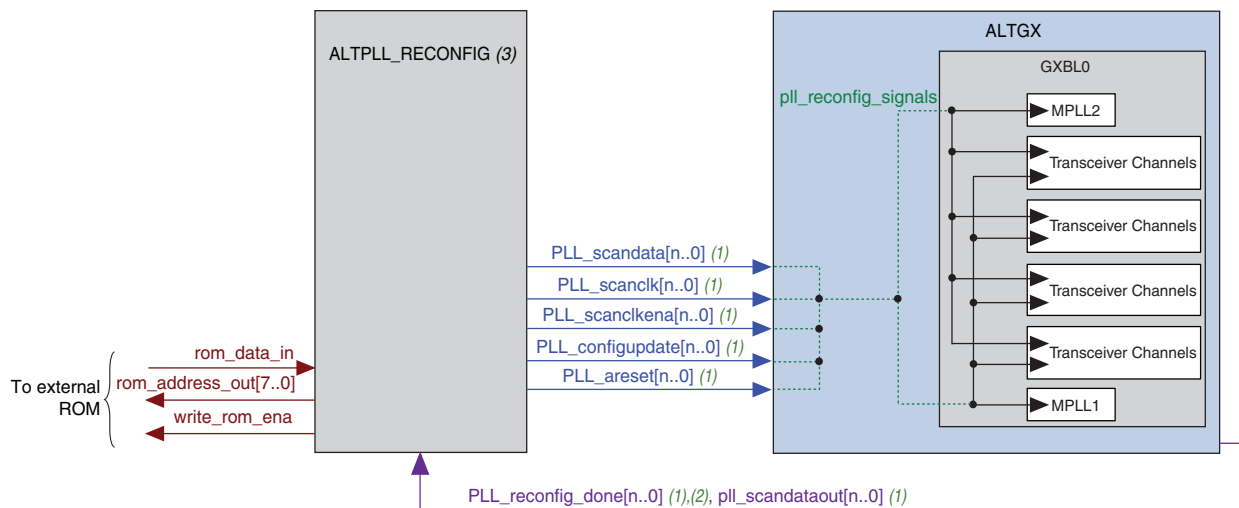

**Notes to Figure 3-16:**

- (1)  $\langle n \rangle =$  (number of transceiver PLLs configured in the ALTGX MegaWizard) - 1.
- (2) You must connect the `pll_reconfig_done` signal from the ALTGX to the `pll_scandone` port from ALTPLL\_RECONFIG.
- (3) You need two ALTPLL\_RECONFIG controllers if you have two separate ALTGX instances with transceiver PLL instantiated in each ALTGX instance.

For more information about connecting the ALTPLL\_RECONFIG and ALTGX instances, refer to the [AN 609: Implementing Dynamic Reconfiguration in Cyclone IV GX Devices](#).

Table 3-7 lists the ALTGX megafunction ports for PLL Reconfiguration mode.

**Table 3-7. ALTGX Megafunction Port List for PLL Reconfiguration Mode**

Port Name <sup>(1)</sup>	Input/Output	Description	Comments
pll_areset [n..0]	Input	Resets the transceiver PLL. The pll_areset are asserted in two conditions: <ul style="list-style-type: none"> <li>Used to reset the transceiver PLL during the reset sequence. During reset sequence, this signal is user controlled.</li> <li>After the transceiver PLL is reconfigured, this signal is asserted high by the ALTPLL_RECONFIG controller. At this time, this signal is not user controlled.</li> </ul>	You must connect the pll_areset port of ALTGX to the pll_areset port of the ALTPLL_RECONFIG megafunction. The ALTPLL_RECONFIG controller asserts the pll_areset port at the next rising clock edge after the pll_reconfig_done signal from the ALTGX megafunction goes high. After the pll_reconfig_done signal goes high, the transceiver PLL is reset. When the PLL reconfiguration is completed, this reset is performed automatically by the ALTPLL_RECONFIG megafunction and is not user controlled.
pll_scandata [n..0]	Input	Receives the scan data input from the ALTPLL_RECONFIG megafunction.	The reconfigurable transceiver PLL received the scan data input through this port for the dynamically reconfigurable bits from the ALTPLL_RECONFIG controller.
pll_scanclk [n..0]	Input	Drives the scanclk port on the reconfigurable transceiver PLL.	Connect the pll_scanclk port of the ALTGX megafunction to the ALTPLL_RECONFIG scanclk port.
pll_scanckena [n..0]	Input	Acts as a clock enable for the scanclk port on the reconfigurable transceiver PLL.	Connect the pll_scanckena port of the ALTGX megafunction to the ALTPLL_RECONFIG scanclk port.
pll_configupdate [n..0]	Input	Drives the configupdate port on the reconfigurable transceiver PLL.	This port is connected to the pll_configupdate port from the ALTPLL_RECONFIG controller. After the final data bit is sent out, the ALTPLL_RECONFIG controller asserts this signal.
pll_reconfig_done[n..0]	Output	This signal is asserted to indicate the reconfiguration process is done.	Connect the pll_reconfig_done port to the pll_scandone port on the ALTPLL_RECONFIG controller. The transceiver PLL scandone output signal drives this port and determines when the PLL is reconfigured.
pll_scandataout [n..0]	Output	This port scan out the current configuration of the transceiver PLL.	Connect the pll_scandataout port to the pll_scandataout port of the ALTPLL_RECONFIG controller. This port reads the current configuration of the transceiver PLL and send it to the ALTPLL_RECONFIG megafunction.

**Note to Table 3-7:**

(1) <n> = (number of transceiver PLLs configured in the ALTGX MegaWizard) - 1.

 For more information about the ALTPLL\_RECONFIG megafunction port list, description and usage, refer to the *Phase-Locked Loop Reconfiguration (ALTPLL\_RECONFIG) Megafunction User Guide*.

If you are reconfiguring the multipurpose PLL with a different M counter value, follow these steps:

1. During transceiver PLL reconfiguration, assert `tx_digitalreset`, `rx_digitalreset`, and `rx_analogreset` signals.
2. Perform PLL reconfiguration to update the multipurpose PLL with the PLL `.mif` files.
3. Perform channel reconfiguration and update the transceiver with the GXB reconfiguration `.mif` files. If you have multiple channel instantiations connected to the same multipurpose PLL, reconfigure each channel.
4. Deassert `tx_digitalreset` and `rx_analogreset` signals.
5. After the `rx_freqlocked` signal goes high, wait for at least 4  $\mu$ s, and then deassert the `rx_digitalreset` signal.

## Error Indication During Dynamic Reconfiguration

The ALTGX\_RECONFIG MegaWizard Plug-In Manager provides an error status signal when you select the **Enable illegal mode checking** option or the **Enable self recovery** option in the **Error checks/data rate switch** screen. The conditions under which the error signal is asserted are:

- **Enable illegal mode checking option**—when you select this option, the dynamic reconfiguration controller checks whether an attempted operation falls under one of the conditions listed below. The dynamic reconfiguration controller detects these conditions within two `reconfig_clk` cycles, deasserts the busy signal, and asserts the error signal for two `reconfig_clk` cycles.
  - PMA controls, read operation—none of the output ports (`rx_eqctrl_out`, `rx_eqdcgain_out`, `tx_vodctrl_out`, and `tx_preemp_out`) are selected in the ALTGX\_RECONFIG instance and the read signal is asserted.
  - PMA controls, write operation—none of the input ports (`rx_eqctrl`, `rx_eqdcgain`, `tx_vodctrl`, and `tx_preemp`) are selected in the ALTGX\_RECONFIG instance and the `write_all` signal is asserted.
- **Channel reconfiguration and PMA reconfiguration mode select - read operation option**:
  - The `reconfig_mode_sel` input port is set to `3'b001` (Channel reconfiguration mode)
  - The read signal is asserted
- **Enable self recovery option**—when you select this option, the ALTGX\_RECONFIG MegaWizard Plug-In Manager provides the error output port. The dynamic reconfiguration controller quits an operation if it did not complete within the expected number of clock cycles. After recovering from the illegal operation, the dynamic reconfiguration controller deasserts the busy signal and asserts the error output port for two `reconfig_clk` cycles.



The error signal is not asserted when an illegal value is written to any of the PMA controls.

## Functional Simulation of the Dynamic Reconfiguration Process

This section describes the points to be considered during functional simulation of the dynamic reconfiguration process.

- You must connect the ALTGX\_RECONFIG instance to the ALTGX\_instance/ALTGX instances in your design for functional simulation.
- The functional simulation uses a reduced timing model of the dynamic reconfiguration controller. The duration of the offset cancellation process is 16 reconfig\_clk clock cycles for functional simulation only.
- The gxb\_powerdown signal must not be asserted during the offset cancellation sequence (for functional simulation and silicon).

## Document Revision History

Table 3-8 lists the revision history for this chapter.

**Table 3-8. Document Revision History**

Date	Version	Changes
November 2011	2.1	<ul style="list-style-type: none"> <li>■ Updated “Dynamic Reconfiguration Controller Architecture”, “PMA Controls Reconfiguration Mode”, “PLL Reconfiguration Mode”, and “Error Indication During Dynamic Reconfiguration” sections.</li> <li>■ Updated Table 3-2 and Table 3-4.</li> </ul>
December 2010	2.0	<ul style="list-style-type: none"> <li>■ Updated for the Quartus II software version 10.1 release.</li> <li>■ Updated Table 3-1, Table 3-2, Table 3-3, Table 3-4, Table 3-5, and Table 3-6.</li> <li>■ Added Table 3-7.</li> <li>■ Updated Figure 3-1, Figure 3-11, Figure 3-13, and Figure 3-14.</li> <li>■ Updated “Offset Cancellation Feature”, “Error Indication During Dynamic Reconfiguration”, “Data Rate Reconfiguration Mode Using RX Local Divider”, “PMA Controls Reconfiguration Mode”, and “Control and Status Signals for Channel Reconfiguration” sections.</li> </ul>
July 2010	1.0	Initial release.





# **Cyclone IV Device Handbook,**

---

## **Volume 3**



101 Innovation Drive  
San Jose, CA 95134  
[www.altera.com](http://www.altera.com)

CYIV-5V3-2.1

© 2016 Altera Corporation. All rights reserved. ALTERA, ARRIA, CYCLONE, HARDCOPY, MAX, MEGACORE, NIOS, QUARTUS and STRATIX words and logos are trademarks of Altera Corporation and registered in the U.S. Patent and Trademark Office and in other countries. All other words and logos identified as trademarks or service marks are the property of their respective holders as described at [www.altera.com/common/legal.html](http://www.altera.com/common/legal.html). Altera warrants performance of its semiconductor products to current specifications in accordance with Altera's standard warranty, but reserves the right to make changes to any products and services at any time without notice. Altera assumes no responsibility or liability arising out of the application or use of any information, product, or service described herein except as expressly agreed to in writing by Altera. Altera customers are advised to obtain the latest version of device specifications before relying on any published information and before placing orders for products or services.



<b>Chapter Revision Dates</b> .....	v
-------------------------------------	---

## Additional Information

How to Contact Altera .....	Info-1
Typographic Conventions .....	Info-1

## Section I. Device Datasheet

### Chapter 1. Cyclone IV Device Datasheet

Operating Conditions .....	1-1
Absolute Maximum Ratings .....	1-2
Maximum Allowed Overshoot or Undershoot Voltage .....	1-2
Recommended Operating Conditions .....	1-4
ESD Performance .....	1-6
DC Characteristics .....	1-7
Supply Current .....	1-7
Bus Hold .....	1-7
OCT Specifications .....	1-8
Pin Capacitance .....	1-10
Internal Weak Pull-Up and Weak Pull-Down Resistor .....	1-11
Hot-Socketing .....	1-11
Schmitt Trigger Input .....	1-12
I/O Standard Specifications .....	1-12
Power Consumption .....	1-16
Switching Characteristics .....	1-16
Transceiver Performance Specifications .....	1-17
Core Performance Specifications .....	1-23
Clock Tree Specifications .....	1-23
PLL Specifications .....	1-24
Embedded Multiplier Specifications .....	1-26
Memory Block Specifications .....	1-26
Configuration and JTAG Specifications .....	1-26
Periphery Performance .....	1-27
High-Speed I/O Specifications .....	1-28
External Memory Interface Specifications .....	1-32
Duty Cycle Distortion Specifications .....	1-33
OCT Calibration Timing Specification .....	1-33
IOE Programmable Delay .....	1-34
I/O Timing .....	1-37
Glossary .....	1-37
Document Revision History .....	1-42





The chapters in this document, Cyclone IV Device Handbook, were revised on the following dates. Where chapters or groups of chapters are available separately, part numbers are listed.

- Chapter 1. Cyclone IV Device Datasheet  
Revised: *December 2016*  
Part Number: *CYIV-53001-2.1*



This chapter provides additional information about the document and Altera.

## About this Handbook

This handbook provides comprehensive information about the Altera® Cyclone® IV family of devices.

## How to Contact Altera

To locate the most up-to-date information about Altera products, refer to the following table.

Contact <sup>(1)</sup>	Contact Method	Address
Technical support	Website	<a href="http://www.altera.com/support">www.altera.com/support</a>
Technical training	Website	<a href="http://www.altera.com/training">www.altera.com/training</a>
	Email	<a href="mailto:custrain@altera.com">custrain@altera.com</a>
Product literature	Website	<a href="http://www.altera.com/literature">www.altera.com/literature</a>
Nontechnical support (general) (software licensing)	Email	<a href="mailto:nacomp@altera.com">nacomp@altera.com</a>
	Email	<a href="mailto:authorization@altera.com">authorization@altera.com</a>









**Note to Table:**

(1) You can also contact your local Altera sales office or sales representative.

## Typographic Conventions

The following table shows the typographic conventions this document uses.

Visual Cue	Meaning
<b>Bold Type with Initial Capital Letters</b>	Indicate command names, dialog box titles, dialog box options, and other GUI labels. For example, <b>Save As</b> dialog box. For GUI elements, capitalization matches the GUI.
<b>bold type</b>	Indicates directory names, project names, disk drive names, file names, file name extensions, software utility names, and GUI labels. For example, <code>\qdesigns</code> directory, <b>D:</b> drive, and <b>chiptrip.gdf</b> file.
<i>Italic Type with Initial Capital Letters</i>	Indicate document titles. For example, <i>Stratix IV Design Guidelines</i> .
<i>italic type</i>	Indicates variables. For example, $n + 1$ . Variable names are enclosed in angle brackets (< >). For example, <file name> and <project name>.pof file.
Initial Capital Letters	Indicate keyboard keys and menu names. For example, the Delete key and the Options menu.
“Subheading Title”	Quotation marks indicate references to sections in a document and titles of Quartus II Help topics. For example, “Typographic Conventions.”

Visual Cue	Meaning
Courier type	<p>Indicates signal, port, register, bit, block, and primitive names. For example, <code>data1</code>, <code>tdi</code>, and <code>input</code>. The suffix <code>n</code> denotes an active-low signal. For example, <code>resetn</code>.</p> <p>Indicates command line commands and anything that must be typed exactly as it appears. For example, <code>c:\qdesigns\tutorial\chiptrip.gdf</code>.</p> <p>Also indicates sections of an actual file, such as a Report File, references to parts of files (for example, the AHDL keyword <code>SUBDESIGN</code>), and logic function names (for example, <code>TRI</code>).</p>
	An angled arrow instructs you to press the Enter key.
1., 2., 3., and a., b., c., and so on	Numbered steps indicate a list of items when the sequence of the items is important, such as the steps listed in a procedure.
	Bullets indicate a list of items when the sequence of the items is not important.
	The hand points to information that requires special attention.
	The question mark directs you to a software help system with related information.
	The feet direct you to another document or website with related information.
	The multimedia icon directs you to a related multimedia presentation.
	A caution calls attention to a condition or possible situation that can damage or destroy the product or your work.
	A warning calls attention to a condition or possible situation that can cause you injury.
	The envelope links to the <a href="#">Email Subscription Management Center</a> page of the Altera website, where you can sign up to receive update notifications for Altera documents.

This section provides the Cyclone® IV device datasheet. It includes the following chapter:

- [Chapter 1, Cyclone IV Device Datasheet](#)

### Revision History

Refer to each chapter for its own specific revision history. For information about when each chapter was updated, refer to the Chapter Revision Dates section, which appears in the complete handbook.



This chapter describes the electrical and switching characteristics for Cyclone® IV devices. Electrical characteristics include operating conditions and power consumption. Switching characteristics include transceiver specifications, core, and periphery performance. This chapter also describes I/O timing, including programmable I/O element (IOE) delay and programmable output buffer delay.

This chapter includes the following sections:

- “Operating Conditions” on page 1–1
- “Power Consumption” on page 1–16
- “Switching Characteristics” on page 1–16
- “I/O Timing” on page 1–37
- “Glossary” on page 1–37

## Operating Conditions

When Cyclone IV devices are implemented in a system, they are rated according to a set of defined parameters. To maintain the highest possible performance and reliability of Cyclone IV devices, you must consider the operating requirements described in this chapter.

Cyclone IV devices are offered in commercial, industrial, extended industrial and, automotive grades. Cyclone IV E devices offer –6 (fastest), –7, –8, –8L, and –9L speed grades for commercial devices, –8L speed grades for industrial devices, and –7 speed grade for extended industrial and automotive devices. Cyclone IV GX devices offer –6 (fastest), –7, and –8 speed grades for commercial devices and –7 speed grade for industrial devices.

 For more information about the supported speed grades for respective Cyclone IV devices, refer to the [Cyclone IV FPGA Device Family Overview](#) chapter.

 Cyclone IV E devices are offered in core voltages of 1.0 and 1.2 V. Cyclone IV E devices with a core voltage of 1.0 V have an ‘L’ prefix attached to the speed grade.

In this chapter, a prefix associated with the operating temperature range is attached to the speed grades; commercial with a “C” prefix, industrial with an “I” prefix, and automotive with an “A” prefix. Therefore, commercial devices are indicated as C6, C7, C8, C8L, or C9L per respective speed grade. Industrial devices are indicated as I7, I8, or I8L. Automotive devices are indicated as A7.

 Cyclone IV E industrial devices I7 are offered with extended operating temperature range.

## Absolute Maximum Ratings

Absolute maximum ratings define the maximum operating conditions for Cyclone IV devices. The values are based on experiments conducted with the device and theoretical modeling of breakdown and damage mechanisms. The functional operation of the device is not implied at these conditions. Table 1-1 lists the absolute maximum ratings for Cyclone IV devices.



Conditions beyond those listed in Table 1-1 cause permanent damage to the device. Additionally, device operation at the absolute maximum ratings for extended periods of time have adverse effects on the device.

**Table 1-1. Absolute Maximum Ratings for Cyclone IV Devices <sup>(1)</sup>**

Symbol	Parameter	Min	Max	Unit
$V_{CCINT}$	Core voltage, PCI Express® (PCIe®) hard IP block, and transceiver physical coding sublayer (PCS) power supply	-0.5	1.8	V
$V_{CCA}$	Phase-locked loop (PLL) analog power supply	-0.5	3.75	V
$V_{CCD\_PLL}$	PLL digital power supply	-0.5	1.8	V
$V_{CCIO}$	I/O banks power supply	-0.5	3.75	V
$V_{CC\_CLKIN}$	Differential clock input pins power supply	-0.5	4.5	V
$V_{CCH\_GXB}$	Transceiver output buffer power supply	-0.5	3.75	V
$V_{CCA\_GXB}$	Transceiver physical medium attachment (PMA) and auxiliary power supply	-0.5	3.75	V
$V_{CCL\_GXB}$	Transceiver PMA and auxiliary power supply	-0.5	1.8	V
$V_I$	DC input voltage	-0.5	4.2	V
$I_{OUT}$	DC output current, per pin	-25	40	mA
$T_{STG}$	Storage temperature	-65	150	°C
$T_J$	Operating junction temperature	-40	125	°C

**Note to Table 1-1:**

- (1) Supply voltage specifications apply to voltage readings taken at the device pins with respect to ground, not at the power supply.

## Maximum Allowed Overshoot or Undershoot Voltage

During transitions, input signals may overshoot to the voltage shown in Table 1-2 and undershoot to -2.0 V for a magnitude of currents less than 100 mA and for periods shorter than 20 ns. Table 1-2 lists the maximum allowed input overshoot voltage and the duration of the overshoot voltage as a percentage over the lifetime of the device. The maximum allowed overshoot duration is specified as a percentage of high-time over the lifetime of the device.

 A DC signal is equivalent to 100% duty cycle. For example, a signal that overshoots to 4.3 V can only be at 4.3 V for 65% over the lifetime of the device; for a device lifetime of 10 years, this amounts to 65/10ths of a year.

**Table 1–2. Maximum Allowed Overshoot During Transitions over a 10-Year Time Frame for Cyclone IV Devices**

Symbol	Parameter	Condition (V)	Overshoot Duration as % of High Time	Unit
$V_i$	AC Input Voltage	$V_i = 4.20$	100	%
		$V_i = 4.25$	98	%
		$V_i = 4.30$	65	%
		$V_i = 4.35$	43	%
		$V_i = 4.40$	29	%
		$V_i = 4.45$	20	%
		$V_i = 4.50$	13	%
		$V_i = 4.55$	9	%
		$V_i = 4.60$	6	%

Figure 1–1 shows the methodology to determine the overshoot duration. The overshoot voltage is shown in red and is present on the input pin of the Cyclone IV device at over 4.3 V but below 4.4 V. From Table 1–2, for an overshoot of 4.3 V, the percentage of high time for the overshoot can be as high as 65% over a 10-year period. Percentage of high time is calculated as  $([\Delta T]/T) \times 100$ . This 10-year period assumes that the device is always turned on with 100% I/O toggle rate and 50% duty cycle signal. For lower I/O toggle rates and situations in which the device is in an idle state, lifetimes are increased.

**Figure 1–1. Cyclone IV Devices Overshoot Duration**

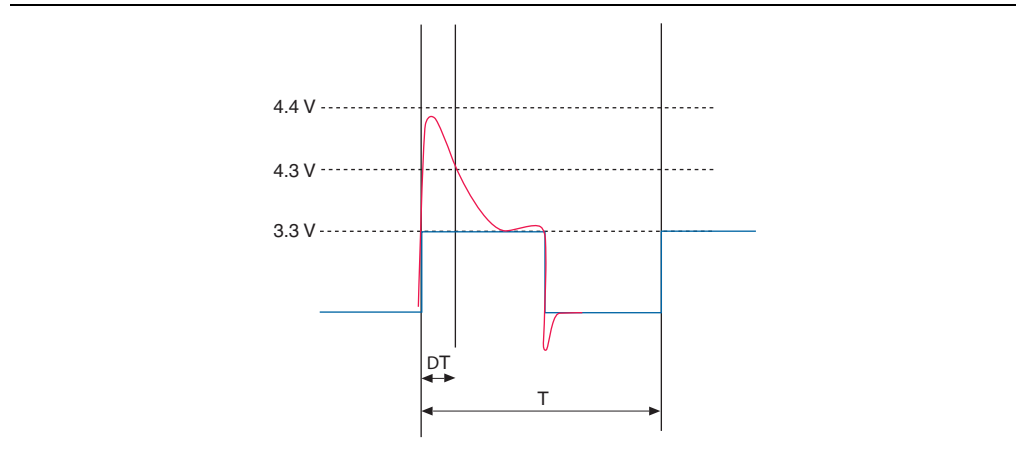

## Recommended Operating Conditions

This section lists the functional operation limits for AC and DC parameters for Cyclone IV devices. Table 1-3 and Table 1-4 list the steady-state voltage and current values expected from Cyclone IV E and Cyclone IV GX devices. All supplies must be strictly monotonic without plateaus.

**Table 1-3. Recommended Operating Conditions for Cyclone IV E Devices <sup>(1), (2)</sup> (Part 1 of 2)**

Symbol	Parameter	Conditions	Min	Typ	Max	Unit
$V_{CCINT}$ <sup>(3)</sup>	Supply voltage for internal logic, 1.2-V operation	—	1.15	1.2	1.25	V
	Supply voltage for internal logic, 1.0-V operation	—	0.97	1.0	1.03	V
$V_{CCIO}$ <sup>(3), (4)</sup>	Supply voltage for output buffers, 3.3-V operation	—	3.135	3.3	3.465	V
	Supply voltage for output buffers, 3.0-V operation	—	2.85	3	3.15	V
	Supply voltage for output buffers, 2.5-V operation	—	2.375	2.5	2.625	V
	Supply voltage for output buffers, 1.8-V operation	—	1.71	1.8	1.89	V
	Supply voltage for output buffers, 1.5-V operation	—	1.425	1.5	1.575	V
	Supply voltage for output buffers, 1.2-V operation	—	1.14	1.2	1.26	V
$V_{CCA}$ <sup>(3)</sup>	Supply (analog) voltage for PLL regulator	—	2.375	2.5	2.625	V
$V_{CCD\_PLL}$ <sup>(3)</sup>	Supply (digital) voltage for PLL, 1.2-V operation	—	1.15	1.2	1.25	V
	Supply (digital) voltage for PLL, 1.0-V operation	—	0.97	1.0	1.03	V
$V_I$	Input voltage	—	-0.5	—	3.6	V
$V_O$	Output voltage	—	0	—	$V_{CCIO}$	V
$T_J$	Operating junction temperature	For commercial use	0	—	85	°C
		For industrial use	-40	—	100	°C
		For extended temperature	-40	—	125	°C
		For automotive use	-40	—	125	°C
$t_{RAMP}$	Power supply ramp time	Standard power-on reset (POR) <sup>(5)</sup>	50 $\mu$ s	—	50 ms	—
		Fast POR <sup>(6)</sup>	50 $\mu$ s	—	3 ms	—

**Table 1-3. Recommended Operating Conditions for Cyclone IV E Devices <sup>(1), (2)</sup> (Part 2 of 2)**

Symbol	Parameter	Conditions	Min	Typ	Max	Unit
$I_{Diode}$	Magnitude of DC current across PCI-clamp diode when enable	—	—	—	10	mA

**Notes to Table 1-3:**

- (1) Cyclone IV E 1.0 V core voltage devices only support C8L, C9L, and I8L speed grades. Cyclone IV E 1.2 V core voltage devices only support C6, C7, C8, I7, and A7 speed grades.
- (2)  $V_{CCIO}$  for all I/O banks must be powered up during device operation. All  $v_{CCA}$  pins must be powered to 2.5 V (even when PLLs are not used) and must be powered up and powered down at the same time.
- (3)  $V_{CC}$  must rise monotonically.
- (4)  $V_{CCIO}$  powers all input buffers.
- (5) The POR time for Standard POR ranges between 50 and 200 ms. Each individual power supply must reach the recommended operating range within 50 ms.
- (6) The POR time for Fast POR ranges between 3 and 9 ms. Each individual power supply must reach the recommended operating range within 3 ms.

**Table 1-4. Recommended Operating Conditions for Cyclone IV GX Devices (Part 1 of 2)**

Symbol	Parameter	Conditions	Min	Typ	Max	Unit
$V_{CCINT}$ <sup>(3)</sup>	Core voltage, PCIe hard IP block, and transceiver PCS power supply	—	1.16	1.2	1.24	V
$V_{CCA}$ <sup>(1), (3)</sup>	PLL analog power supply	—	2.375	2.5	2.625	V
$V_{CCD\_PLL}$ <sup>(2)</sup>	PLL digital power supply	—	1.16	1.2	1.24	V
$V_{CCIO}$ <sup>(3), (4)</sup>	I/O banks power supply for 3.3-V operation	—	3.135	3.3	3.465	V
	I/O banks power supply for 3.0-V operation	—	2.85	3	3.15	V
	I/O banks power supply for 2.5-V operation	—	2.375	2.5	2.625	V
	I/O banks power supply for 1.8-V operation	—	1.71	1.8	1.89	V
	I/O banks power supply for 1.5-V operation	—	1.425	1.5	1.575	V
	I/O banks power supply for 1.2-V operation	—	1.14	1.2	1.26	V
$V_{CC\_CLKIN}$ <sup>(3), (5), (6)</sup>	Differential clock input pins power supply for 3.3-V operation	—	3.135	3.3	3.465	V
	Differential clock input pins power supply for 3.0-V operation	—	2.85	3	3.15	V
	Differential clock input pins power supply for 2.5-V operation	—	2.375	2.5	2.625	V
	Differential clock input pins power supply for 1.8-V operation	—	1.71	1.8	1.89	V
	Differential clock input pins power supply for 1.5-V operation	—	1.425	1.5	1.575	V
	Differential clock input pins power supply for 1.2-V operation	—	1.14	1.2	1.26	V
$V_{CCH\_GXB}$	Transceiver output buffer power supply	—	2.375	2.5	2.625	V

**Table 1-4. Recommended Operating Conditions for Cyclone IV GX Devices (Part 2 of 2)**

Symbol	Parameter	Conditions	Min	Typ	Max	Unit
$V_{CCA\_GXB}$	Transceiver PMA and auxiliary power supply	—	2.375	2.5	2.625	V
$V_{CCL\_GXB}$	Transceiver PMA and auxiliary power supply	—	1.16	1.2	1.24	V
$V_I$	DC input voltage	—	-0.5	—	3.6	V
$V_O$	DC output voltage	—	0	—	$V_{CCIO}$	V
$T_J$	Operating junction temperature	For commercial use	0	—	85	°C
		For industrial use	-40	—	100	°C
$t_{RAMP}$	Power supply ramp time	Standard power-on reset (POR) <sup>(7)</sup>	50 $\mu$ s	—	50 ms	—
		Fast POR <sup>(8)</sup>	50 $\mu$ s	—	3 ms	—
$I_{Diode}$	Magnitude of DC current across PCI-clamp diode when enabled	—	—	—	10	mA

**Notes to Table 1-4:**

- All  $V_{CCA}$  pins must be powered to 2.5 V (even when PLLs are not used) and must be powered up and powered down at the same time.
- You must connect  $V_{CCD\_PLL}$  to  $V_{CCINT}$  through a decoupling capacitor and ferrite bead.
- Power supplies must rise monotonically.
- $V_{CCIO}$  for all I/O banks must be powered up during device operation. Configuration pins are powered up by  $V_{CCIO}$  of I/O Banks 3, 8, and 9 where I/O Banks 3 and 9 only support  $V_{CCIO}$  of 1.5, 1.8, 2.5, 3.0, and 3.3 V. For fast passive parallel (FPP) configuration mode, the  $V_{CCIO}$  level of I/O Bank 8 must be powered up to 1.5, 1.8, 2.5, 3.0, and 3.3 V.
- You must set  $V_{CC\_CLKIN}$  to 2.5 V if you use  $CLKIN$  as a high-speed serial interface (HSSI)  $refclk$  or as a  $DIFFCLK$  input.
- The  $CLKIN$  pins in I/O Banks 3B and 8B can support single-ended I/O standard when the pins are used to clock left PLLs in non-transceiver applications.
- The POR time for Standard POR ranges between 50 and 200 ms.  $V_{CCINT}$ ,  $V_{CCA}$ , and  $V_{CCIO}$  of I/O Banks 3, 8, and 9 must reach the recommended operating range within 50 ms.
- The POR time for Fast POR ranges between 3 and 9 ms.  $V_{CCINT}$ ,  $V_{CCA}$ , and  $V_{CCIO}$  of I/O Banks 3, 8, and 9 must reach the recommended operating range within 3 ms.

## ESD Performance

This section lists the electrostatic discharge (ESD) voltages using the human body model (HBM) and charged device model (CDM) for Cyclone IV devices general purpose I/Os (GPIOs) and high-speed serial interface (HSSI) I/Os. Table 1-5 lists the ESD for Cyclone IV devices GPIOs and HSSI I/Os.

**Table 1-5. ESD for Cyclone IV Devices GPIOs and HSSI I/Os**

Symbol	Parameter	Passing Voltage	Unit
$V_{ESDHBM}$	ESD voltage using the HBM (GPIOs) <sup>(1)</sup>	$\pm 2000$	V
	ESD using the HBM (HSSI I/Os) <sup>(2)</sup>	$\pm 1000$	V
$V_{ESDCDM}$	ESD using the CDM (GPIOs)	$\pm 500$	V
	ESD using the CDM (HSSI I/Os) <sup>(2)</sup>	$\pm 250$	V

**Notes to Table 1-5:**

- The passing voltage for EP4CGX15 and EP4CGX30 row I/Os is  $\pm 1000$ V.
- This value is applicable only to Cyclone IV GX devices.

## DC Characteristics

This section lists the I/O leakage current, pin capacitance, on-chip termination (OCT) tolerance, and bus hold specifications for Cyclone IV devices.

### Supply Current

The device supply current requirement is the minimum current drawn from the power supply pins that can be used as a reference for power size planning. Use the Excel-based early power estimator (EPE) to get the supply current estimates for your design because these currents vary greatly with the resources used. Table 1-6 lists the I/O pin leakage current for Cyclone IV devices.

**Table 1-6. I/O Pin Leakage Current for Cyclone IV Devices <sup>(1), (2)</sup>**

Symbol	Parameter	Conditions	Device	Min	Typ	Max	Unit
$I_I$	Input pin leakage current	$V_I = 0\text{ V to }V_{CCIO\text{MAX}}$	—	-10	—	10	$\mu\text{A}$
$I_{OZ}$	Tristated I/O pin leakage current	$V_O = 0\text{ V to }V_{CCIO\text{MAX}}$	—	-10	—	10	$\mu\text{A}$

**Notes to Table 1-6:**

- (1) This value is specified for normal device operation. The value varies during device power-up. This applies for all  $V_{CCIO}$  settings (3.3, 3.0, 2.5, 1.8, 1.5, and 1.2 V).
- (2) The 10  $\mu\text{A}$  I/O leakage current limit is applicable when the internal clamping diode is off. A higher current can be observed when the diode is on.

### Bus Hold

The bus hold retains the last valid logic state after the source driving it either enters the high impedance state or is removed. Each I/O pin has an option to enable bus hold in user mode. Bus hold is always disabled in configuration mode.

Table 1-7 lists bus hold specifications for Cyclone IV devices.

**Table 1-7. Bus Hold Parameter for Cyclone IV Devices (Part 1 of 2) <sup>(1)</sup>**

Parameter	Condition	$V_{CCIO}$ (V)												Unit
		1.2		1.5		1.8		2.5		3.0		3.3		
		Min	Max	Min	Max	Min	Max	Min	Max	Min	Max	Min	Max	
Bus hold low, sustaining current	$V_{IN} > V_{IL}$ (maximum)	8	—	12	—	30	—	50	—	70	—	70	—	$\mu\text{A}$
Bus hold high, sustaining current	$V_{IN} < V_{IL}$ (minimum)	-8	—	-12	—	-30	—	-50	—	-70	—	-70	—	$\mu\text{A}$
Bus hold low, overdrive current	$0\text{ V} < V_{IN} < V_{CCIO}$	—	125	—	175	—	200	—	300	—	500	—	500	$\mu\text{A}$
Bus hold high, overdrive current	$0\text{ V} < V_{IN} < V_{CCIO}$	—	-125	—	-175	—	-200	—	-300	—	-500	—	-500	$\mu\text{A}$

**Table 1-7. Bus Hold Parameter for Cyclone IV Devices (Part 2 of 2) <sup>(1)</sup>**

Parameter	Condition	V <sub>CCIO</sub> (V)												Unit
		1.2		1.5		1.8		2.5		3.0		3.3		
		Min	Max	Min	Max	Min	Max	Min	Max	Min	Max	Min	Max	
Bus hold trip point	—	0.3	0.9	0.375	1.125	0.68	1.07	0.7	1.7	0.8	2	0.8	2	V

**Note to Table 1-7:**

(1) Bus hold trip points are based on the calculated input voltages from the JEDEC standard.

## OCT Specifications

Table 1-8 lists the variation of OCT without calibration across process, temperature, and voltage (PVT).

**Table 1-8. Series OCT Without Calibration Specifications for Cyclone IV Devices**

Description	V <sub>CCIO</sub> (V)	Resistance Tolerance		Unit
		Commercial Maximum	Industrial, Extended industrial, and Automotive Maximum	
Series OCT without calibration	3.0	±30	±40	%
	2.5	±30	±40	%
	1.8	±40	±50	%
	1.5	±50	±50	%
	1.2	±50	±50	%

OCT calibration is automatically performed at device power-up for OCT-enabled I/Os.

Table 1-9 lists the OCT calibration accuracy at device power-up.

**Table 1-9. Series OCT with Calibration at Device Power-Up Specifications for Cyclone IV Devices <sup>(1)</sup>**

Description	V <sub>CCIO</sub> (V)	Calibration Accuracy		Unit
		Commercial Maximum	Industrial, Extended industrial, and Automotive Maximum	
Series OCT with calibration at device power-up	3.0	±10	±10	%
	2.5	±10	±10	%
	1.8	±10	±10	%
	1.5	±10	±10	%
	1.2	±10	±10	%

**Note to Table 1-9:**

(1) This specification is not applicable to EP4CGX15, EP4CGX22, and EP4CGX30 devices.

The OCT resistance may vary with the variation of temperature and voltage after calibration at device power-up. Use Table 1-10 and Equation 1-1 to determine the final OCT resistance considering the variations after calibration at device power-up. Table 1-10 lists the change percentage of the OCT resistance with voltage and temperature.

**Table 1-10. OCT Variation After Calibration at Device Power-Up for Cyclone IV Devices <sup>(1)</sup>**

Nominal Voltage	dR/dT (%/°C)	dR/dV (%/mV)
3.0	0.262	-0.026
2.5	0.234	-0.039
1.8	0.219	-0.086
1.5	0.199	-0.136
1.2	0.161	-0.288

**Note to Table 1-10:**

(1) This specification is not applicable to EP4CGX15, EP4CGX22, and EP4CGX30 devices.

**Equation 1-1. Final OCT Resistance <sup>(1), (2), (3), (4), (5), (6)</sup>**

$$\Delta R_V = (V_2 - V_1) \times 1000 \times dR/dV \text{ — (7)}$$

$$\Delta R_T = (T_2 - T_1) \times dR/dT \text{ — (8)}$$

$$\text{For } \Delta R_x < 0; MF_x = 1 / (|\Delta R_x|/100 + 1) \text{ — (9)}$$

$$\text{For } \Delta R_x > 0; MF_x = \Delta R_x/100 + 1 \text{ — (10)}$$

$$MF = MF_V \times MF_T \text{ — (11)}$$

$$R_{\text{final}} = R_{\text{initial}} \times MF \text{ — (12)}$$

**Notes to Equation 1-1:**

- (1)  $T_2$  is the final temperature.
- (2)  $T_1$  is the initial temperature.
- (3) MF is multiplication factor.
- (4)  $R_{\text{final}}$  is final resistance.
- (5)  $R_{\text{initial}}$  is initial resistance.
- (6) Subscript  $x$  refers to both  $v$  and  $t$ .
- (7)  $\Delta R_V$  is a variation of resistance with voltage.
- (8)  $\Delta R_T$  is a variation of resistance with temperature.
- (9) dR/dT is the change percentage of resistance with temperature after calibration at device power-up.
- (10) dR/dV is the change percentage of resistance with voltage after calibration at device power-up.
- (11)  $V_2$  is final voltage.
- (12)  $V_1$  is the initial voltage.

**Example 1-1** shows how to calculate the change of 50-Ω I/O impedance from 25°C at 3.0 V to 85°C at 3.15 V.

### Example 1-1. Impedance Change

$$\Delta R_V = (3.15 - 3) \times 1000 \times -0.026 = -3.83$$

$$\Delta R_T = (85 - 25) \times 0.262 = 15.72$$

Because  $\Delta R_V$  is negative,

$$MF_V = 1 / (3.83/100 + 1) = 0.963$$

Because  $\Delta R_T$  is positive,

$$MF_T = 15.72/100 + 1 = 1.157$$

$$MF = 0.963 \times 1.157 = 1.114$$

$$R_{\text{final}} = 50 \times 1.114 = 55.71 \Omega$$

## Pin Capacitance

**Table 1-11** lists the pin capacitance for Cyclone IV devices.

**Table 1-11. Pin Capacitance for Cyclone IV Devices <sup>(1)</sup>**

Symbol	Parameter	Typical – Quad Flat Pack (QFP)	Typical – Quad Flat No Leads (QFN)	Typical – Ball-Grid Array (BGA)	Unit
C <sub>IOTB</sub>	Input capacitance on top and bottom I/O pins	7	7	6	pF
C <sub>IOLR</sub>	Input capacitance on right I/O pins	7	7	5	pF
C <sub>LVDSLR</sub>	Input capacitance on right I/O pins with dedicated LVDS output	8	8	7	pF
C <sub>VREFLR</sub> (2)	Input capacitance on right dual-purpose V <sub>REF</sub> pin when used as V <sub>REF</sub> or user I/O pin	21	21	21	pF
C <sub>VREFTB</sub> (2)	Input capacitance on top and bottom dual-purpose V <sub>REF</sub> pin when used as V <sub>REF</sub> or user I/O pin	23 (3)	23	23	pF
C <sub>CLKTB</sub>	Input capacitance on top and bottom dedicated clock input pins	7	7	6	pF
C <sub>CLKLR</sub>	Input capacitance on right dedicated clock input pins	6	6	5	pF

#### Notes to Table 1-11:

- (1) The pin capacitance applies to FBGA, UBGA, and MBGA packages.
- (2) When you use the V<sub>REF</sub> pin as a regular input or output, you can expect a reduced performance of toggle rate and t<sub>CO</sub> because of higher pin capacitance.
- (3) C<sub>VREFTB</sub> for the EP4CE22 device is 30 pF.

## Internal Weak Pull-Up and Weak Pull-Down Resistor

Table 1-12 lists the weak pull-up and pull-down resistor values for Cyclone IV devices.

**Table 1-12. Internal Weak Pull-Up and Weak Pull-Down Resistor Values for Cyclone IV Devices <sup>(1)</sup>**

Symbol	Parameter	Conditions	Min	Typ	Max	Unit
R <sub>PU</sub>	Value of the I/O pin pull-up resistor before and during configuration, as well as user mode if you enable the programmable pull-up resistor option	V <sub>CCIO</sub> = 3.3 V ± 5% <sup>(2), (3)</sup>	7	25	41	kΩ
		V <sub>CCIO</sub> = 3.0 V ± 5% <sup>(2), (3)</sup>	7	28	47	kΩ
		V <sub>CCIO</sub> = 2.5 V ± 5% <sup>(2), (3)</sup>	8	35	61	kΩ
		V <sub>CCIO</sub> = 1.8 V ± 5% <sup>(2), (3)</sup>	10	57	108	kΩ
		V <sub>CCIO</sub> = 1.5 V ± 5% <sup>(2), (3)</sup>	13	82	163	kΩ
		V <sub>CCIO</sub> = 1.2 V ± 5% <sup>(2), (3)</sup>	19	143	351	kΩ
R <sub>PD</sub>	Value of the I/O pin pull-down resistor before and during configuration	V <sub>CCIO</sub> = 3.3 V ± 5% <sup>(4)</sup>	6	19	30	kΩ
		V <sub>CCIO</sub> = 3.0 V ± 5% <sup>(4)</sup>	6	22	36	kΩ
		V <sub>CCIO</sub> = 2.5 V ± 5% <sup>(4)</sup>	6	25	43	kΩ
		V <sub>CCIO</sub> = 1.8 V ± 5% <sup>(4)</sup>	7	35	71	kΩ
		V <sub>CCIO</sub> = 1.5 V ± 5% <sup>(4)</sup>	8	50	112	kΩ

**Notes to Table 1-12:**

- All I/O pins have an option to enable weak pull-up except the configuration, test, and JTAG pins. The weak pull-down feature is only available for JTAG TCK.
- Pin pull-up resistance values may be lower if an external source drives the pin higher than V<sub>CCIO</sub>.
- $R_{PU} = (V_{CCIO} - V_I) / I_{R_{PU}}$   
Minimum condition: -40°C; V<sub>CCIO</sub> = V<sub>CC</sub> + 5%, V<sub>I</sub> = V<sub>CC</sub> + 5% - 50 mV;  
Typical condition: 25°C; V<sub>CCIO</sub> = V<sub>CC</sub>, V<sub>I</sub> = 0 V;  
Maximum condition: 100°C; V<sub>CCIO</sub> = V<sub>CC</sub> - 5%, V<sub>I</sub> = 0 V; in which V<sub>I</sub> refers to the input voltage at the I/O pin.
- $R_{PD} = V_I / I_{R_{PD}}$   
Minimum condition: -40°C; V<sub>CCIO</sub> = V<sub>CC</sub> + 5%, V<sub>I</sub> = 50 mV;  
Typical condition: 25°C; V<sub>CCIO</sub> = V<sub>CC</sub>, V<sub>I</sub> = V<sub>CC</sub> - 5%;  
Maximum condition: 100°C; V<sub>CCIO</sub> = V<sub>CC</sub> - 5%, V<sub>I</sub> = V<sub>CC</sub> - 5%; in which V<sub>I</sub> refers to the input voltage at the I/O pin.

## Hot-Socketing

Table 1-13 lists the hot-socketing specifications for Cyclone IV devices.

**Table 1-13. Hot-Socketing Specifications for Cyclone IV Devices**

Symbol	Parameter	Maximum
I <sub>IOPIN(DC)</sub>	DC current per I/O pin	300 μA
I <sub>IOPIN(AC)</sub>	AC current per I/O pin	8 mA <sup>(1)</sup>
I <sub>XCVRTX(DC)</sub>	DC current per transceiver TX pin	100 mA
I <sub>XCVRRX(DC)</sub>	DC current per transceiver RX pin	50 mA

**Note to Table 1-13:**

- The I/O ramp rate is 10 ns or more. For ramp rates faster than 10 ns, |I<sub>IOPIN</sub>| = C dv/dt, in which C is the I/O pin capacitance and dv/dt is the slew rate.



During hot-socketing, the I/O pin capacitance is less than 15 pF and the clock pin capacitance is less than 20 pF.

## Schmitt Trigger Input

Cyclone IV devices support Schmitt trigger input on the TDI, TMS, TCK, nSTATUS, nCONFIG, nCE, CONF\_DONE, and DCLK pins. A Schmitt trigger feature introduces hysteresis to the input signal for improved noise immunity, especially for signals with slow edge rate. Table 1-14 lists the hysteresis specifications across the supported  $V_{CCIO}$  range for Schmitt trigger inputs in Cyclone IV devices.

**Table 1-14. Hysteresis Specifications for Schmitt Trigger Input in Cyclone IV Devices**

Symbol	Parameter	Conditions (V)	Minimum	Unit
$V_{SCHMITT}$	Hysteresis for Schmitt trigger input	$V_{CCIO} = 3.3$	200	mV
		$V_{CCIO} = 2.5$	200	mV
		$V_{CCIO} = 1.8$	140	mV
		$V_{CCIO} = 1.5$	110	mV

## I/O Standard Specifications

The following tables list input voltage sensitivities ( $V_{IH}$  and  $V_{IL}$ ), output voltage ( $V_{OH}$  and  $V_{OL}$ ), and current drive characteristics ( $I_{OH}$  and  $I_{OL}$ ), for various I/O standards supported by Cyclone IV devices. Table 1-15 through Table 1-20 provide the I/O standard specifications for Cyclone IV devices.

**Table 1-15. Single-Ended I/O Standard Specifications for Cyclone IV Devices (1), (2)**

I/O Standard	$V_{CCIO}$ (V)			$V_{IL}$ (V)		$V_{IH}$ (V)		$V_{OL}$ (V)	$V_{OH}$ (V)	$I_{OL}$ (mA) (4)	$I_{OH}$ (mA) (4)
	Min	Typ	Max	Min	Max	Min	Max	Max	Min		
3.3-V LVTTTL (3)	3.135	3.3	3.465	—	0.8	1.7	3.6	0.45	2.4	4	-4
3.3-V LVCMOS (3)	3.135	3.3	3.465	—	0.8	1.7	3.6	0.2	$V_{CCIO} - 0.2$	2	-2
3.0-V LVTTTL (3)	2.85	3.0	3.15	-0.3	0.8	1.7	$V_{CCIO} + 0.3$	0.45	2.4	4	-4
3.0-V LVCMOS (3)	2.85	3.0	3.15	-0.3	0.8	1.7	$V_{CCIO} + 0.3$	0.2	$V_{CCIO} - 0.2$	0.1	-0.1
2.5 V (3)	2.375	2.5	2.625	-0.3	0.7	1.7	$V_{CCIO} + 0.3$	0.4	2.0	1	-1
1.8 V	1.71	1.8	1.89	-0.3	$0.35 \times V_{CCIO}$	$0.65 \times V_{CCIO}$	2.25	0.45	$V_{CCIO} - 0.45$	2	-2
1.5 V	1.425	1.5	1.575	-0.3	$0.35 \times V_{CCIO}$	$0.65 \times V_{CCIO}$	$V_{CCIO} + 0.3$	$0.25 \times V_{CCIO}$	$0.75 \times V_{CCIO}$	2	-2
1.2 V	1.14	1.2	1.26	-0.3	$0.35 \times V_{CCIO}$	$0.65 \times V_{CCIO}$	$V_{CCIO} + 0.3$	$0.25 \times V_{CCIO}$	$0.75 \times V_{CCIO}$	2	-2
3.0-V PCI	2.85	3.0	3.15	—	$0.3 \times V_{CCIO}$	$0.5 \times V_{CCIO}$	$V_{CCIO} + 0.3$	$0.1 \times V_{CCIO}$	$0.9 \times V_{CCIO}$	1.5	-0.5
3.0-V PCI-X	2.85	3.0	3.15	—	$0.35 \times V_{CCIO}$	$0.5 \times V_{CCIO}$	$V_{CCIO} + 0.3$	$0.1 \times V_{CCIO}$	$0.9 \times V_{CCIO}$	1.5	-0.5

**Notes to Table 1-15:**

- (1) For voltage-referenced receiver input waveform and explanation of terms used in Table 1-15, refer to "Glossary" on page 1-37.
- (2) AC load CL = 10 pF
- (3) For more information about interfacing Cyclone IV devices with 3.3/3.0/2.5-V LVTTTL/LVCMOS I/O standards, refer to *AN 447: Interfacing Cyclone III and Cyclone IV Devices with 3.3/3.0/2.5-V LVTTTL/LVCMOS I/O Systems*.
- (4) To meet the  $I_{OL}$  and  $I_{OH}$  specifications, you must set the current strength settings accordingly. For example, to meet the 3.3-V LVTTTL specification (4 mA), set the current strength settings to 4 mA or higher. Setting at lower current strength may not meet the  $I_{OL}$  and  $I_{OH}$  specifications in the handbook.

**Table 1-16. Single-Ended SSTL and HSTL I/O Reference Voltage Specifications for Cyclone IV Devices <sup>(1)</sup>**

I/O Standard	V <sub>CCIO</sub> (V)			V <sub>REF</sub> (V)			V <sub>TT</sub> (V) <sup>(2)</sup>		
	Min	Typ	Max	Min	Typ	Max	Min	Typ	Max
SSTL-2 Class I, II	2.375	2.5	2.625	1.19	1.25	1.31	V <sub>REF</sub> - 0.04	V <sub>REF</sub>	V <sub>REF</sub> + 0.04
SSTL-18 Class I, II	1.7	1.8	1.9	0.833	0.9	0.969	V <sub>REF</sub> - 0.04	V <sub>REF</sub>	V <sub>REF</sub> + 0.04
HSTL-18 Class I, II	1.71	1.8	1.89	0.85	0.9	0.95	0.85	0.9	0.95
HSTL-15 Class I, II	1.425	1.5	1.575	0.71	0.75	0.79	0.71	0.75	0.79
HSTL-12 Class I, II	1.14	1.2	1.26	0.48 × V <sub>CCIO</sub> <sup>(3)</sup>	0.5 × V <sub>CCIO</sub> <sup>(3)</sup>	0.52 × V <sub>CCIO</sub> <sup>(3)</sup>	—	0.5 × V <sub>CCIO</sub>	—
				0.47 × V <sub>CCIO</sub> <sup>(4)</sup>	0.5 × V <sub>CCIO</sub> <sup>(4)</sup>	0.53 × V <sub>CCIO</sub> <sup>(4)</sup>			

**Notes to Table 1-16:**

- (1) For an explanation of terms used in Table 1-16, refer to “Glossary” on page 1-37.
- (2) V<sub>TT</sub> of the transmitting device must track V<sub>REF</sub> of the receiving device.
- (3) Value shown refers to DC input reference voltage, V<sub>REF(DC)</sub>.
- (4) Value shown refers to AC input reference voltage, V<sub>REF(AC)</sub>.

**Table 1-17. Single-Ended SSTL and HSTL I/O Standards Signal Specifications for Cyclone IV Devices**

I/O Standard	V <sub>IL(DC)</sub> (V)		V <sub>IH(DC)</sub> (V)		V <sub>IL(AC)</sub> (V)		V <sub>IH(AC)</sub> (V)		V <sub>OL</sub> (V)	V <sub>OH</sub> (V)	I <sub>OL</sub> (mA)	I <sub>OH</sub> (mA)
	Min	Max	Min	Max	Min	Max	Min	Max	Max	Min		
SSTL-2 Class I	—	V <sub>REF</sub> - 0.18	V <sub>REF</sub> + 0.18	—	—	V <sub>REF</sub> - 0.35	V <sub>REF</sub> + 0.35	—	V <sub>TT</sub> - 0.57	V <sub>TT</sub> + 0.57	8.1	-8.1
SSTL-2 Class II	—	V <sub>REF</sub> - 0.18	V <sub>REF</sub> + 0.18	—	—	V <sub>REF</sub> - 0.35	V <sub>REF</sub> + 0.35	—	V <sub>TT</sub> - 0.76	V <sub>TT</sub> + 0.76	16.4	-16.4
SSTL-18 Class I	—	V <sub>REF</sub> - 0.125	V <sub>REF</sub> + 0.125	—	—	V <sub>REF</sub> - 0.25	V <sub>REF</sub> + 0.25	—	V <sub>TT</sub> - 0.475	V <sub>TT</sub> + 0.475	6.7	-6.7
SSTL-18 Class II	—	V <sub>REF</sub> - 0.125	V <sub>REF</sub> + 0.125	—	—	V <sub>REF</sub> - 0.25	V <sub>REF</sub> + 0.25	—	0.28	V <sub>CCIO</sub> - 0.28	13.4	-13.4
HSTL-18 Class I	—	V <sub>REF</sub> - 0.1	V <sub>REF</sub> + 0.1	—	—	V <sub>REF</sub> - 0.2	V <sub>REF</sub> + 0.2	—	0.4	V <sub>CCIO</sub> - 0.4	8	-8
HSTL-18 Class II	—	V <sub>REF</sub> - 0.1	V <sub>REF</sub> + 0.1	—	—	V <sub>REF</sub> - 0.2	V <sub>REF</sub> + 0.2	—	0.4	V <sub>CCIO</sub> - 0.4	16	-16
HSTL-15 Class I	—	V <sub>REF</sub> - 0.1	V <sub>REF</sub> + 0.1	—	—	V <sub>REF</sub> - 0.2	V <sub>REF</sub> + 0.2	—	0.4	V <sub>CCIO</sub> - 0.4	8	-8
HSTL-15 Class II	—	V <sub>REF</sub> - 0.1	V <sub>REF</sub> + 0.1	—	—	V <sub>REF</sub> - 0.2	V <sub>REF</sub> + 0.2	—	0.4	V <sub>CCIO</sub> - 0.4	16	-16
HSTL-12 Class I	-0.15	V <sub>REF</sub> - 0.08	V <sub>REF</sub> + 0.08	V <sub>CCIO</sub> + 0.15	-0.24	V <sub>REF</sub> - 0.15	V <sub>REF</sub> + 0.15	V <sub>CCIO</sub> + 0.24	0.25 × V <sub>CCIO</sub>	0.75 × V <sub>CCIO</sub>	8	-8
HSTL-12 Class II	-0.15	V <sub>REF</sub> - 0.08	V <sub>REF</sub> + 0.08	V <sub>CCIO</sub> + 0.15	-0.24	V <sub>REF</sub> - 0.15	V <sub>REF</sub> + 0.15	V <sub>CCIO</sub> + 0.24	0.25 × V <sub>CCIO</sub>	0.75 × V <sub>CCIO</sub>	14	-14

 For more information about receiver input and transmitter output waveforms, and for other differential I/O standards, refer to the *I/O Features in Cyclone IV Devices* chapter.

**Table 1–18. Differential SSTL I/O Standard Specifications for Cyclone IV Devices <sup>(1)</sup>**

I/O Standard	V <sub>CCIO</sub> (V)			V <sub>Swing(DC)</sub> (V)		V <sub>X(AC)</sub> (V)			V <sub>Swing(AC)</sub> (V)		V <sub>Ox(AC)</sub> (V)		
	Min	Typ	Max	Min	Max	Min	Typ	Max	Min	Max	Min	Typ	Max
SSTL-2 Class I, II	2.375	2.5	2.625	0.36	V <sub>CCIO</sub>	V <sub>CCIO</sub> /2 – 0.2	—	V <sub>CCIO</sub> /2 + 0.2	0.7	V <sub>CCIO</sub>	V <sub>CCIO</sub> /2 – 0.125	—	V <sub>CCIO</sub> /2 + 0.125
SSTL-18 Class I, II	1.7	1.8	1.90	0.25	V <sub>CCIO</sub>	V <sub>CCIO</sub> /2 – 0.175	—	V <sub>CCIO</sub> /2 + 0.175	0.5	V <sub>CCIO</sub>	V <sub>CCIO</sub> /2 – 0.125	—	V <sub>CCIO</sub> /2 + 0.125

Note to Table 1–18:

(1) Differential SSTL requires a V<sub>REF</sub> input.

**Table 1–19. Differential HSTL I/O Standard Specifications for Cyclone IV Devices <sup>(1)</sup>**

I/O Standard	V <sub>CCIO</sub> (V)			V <sub>DIF(DC)</sub> (V)		V <sub>X(AC)</sub> (V)			V <sub>CM(DC)</sub> (V)			V <sub>DIF(AC)</sub> (V)	
	Min	Typ	Max	Min	Max	Min	Typ	Max	Min	Typ	Max	Min	Max
HSTL-18 Class I, II	1.71	1.8	1.89	0.2	—	0.85	—	0.95	0.85	—	0.95	0.4	—
HSTL-15 Class I, II	1.425	1.5	1.575	0.2	—	0.71	—	0.79	0.71	—	0.79	0.4	—
HSTL-12 Class I, II	1.14	1.2	1.26	0.16	V <sub>CCIO</sub>	0.48 x V <sub>CCIO</sub>	—	0.52 x V <sub>CCIO</sub>	0.48 x V <sub>CCIO</sub>	—	0.52 x V <sub>CCIO</sub>	0.3	0.48 x V <sub>CCIO</sub>

Note to Table 1–19:

(1) Differential HSTL requires a V<sub>REF</sub> input.

**Table 1–20. Differential I/O Standard Specifications for Cyclone IV Devices <sup>(1)</sup> (Part 1 of 2)**

I/O Standard	V <sub>CCIO</sub> (V)			V <sub>ID</sub> (mV)		V <sub>ICM</sub> (V) <sup>(2)</sup>			V <sub>OD</sub> (mV) <sup>(3)</sup>			V <sub>OS</sub> (V) <sup>(3)</sup>		
	Min	Typ	Max	Min	Max	Min	Condition	Max	Min	Typ	Max	Min	Typ	Max
LVPECL (Row I/Os) <sup>(6)</sup>	2.375	2.5	2.625	100	—	0.05	D <sub>MAX</sub> ≤ 500 Mbps	1.80	—	—	—	—	—	—
						0.55	500 Mbps ≤ D <sub>MAX</sub> ≤ 700 Mbps	1.80						
						1.05	D <sub>MAX</sub> > 700 Mbps	1.55						
LVPECL (Column I/Os) <sup>(6)</sup>	2.375	2.5	2.625	100	—	0.05	D <sub>MAX</sub> ≤ 500 Mbps	1.80	—	—	—	—	—	—
						0.55	500 Mbps ≤ D <sub>MAX</sub> ≤ 700 Mbps	1.80						
						1.05	D <sub>MAX</sub> > 700 Mbps	1.55						
LVDS (Row I/Os)	2.375	2.5	2.625	100	—	0.05	D <sub>MAX</sub> ≤ 500 Mbps	1.80	247	—	600	1.125	1.25	1.375
						0.55	500 Mbps ≤ D <sub>MAX</sub> ≤ 700 Mbps	1.80						
						1.05	D <sub>MAX</sub> > 700 Mbps	1.55						

**Table 1–20. Differential I/O Standard Specifications for Cyclone IV Devices <sup>(1)</sup> (Part 2 of 2)**

I/O Standard	V <sub>CCIO</sub> (V)			V <sub>ID</sub> (mV)		V <sub>ICM</sub> (V) <sup>(2)</sup>			V <sub>OD</sub> (mV) <sup>(3)</sup>			V <sub>OS</sub> (V) <sup>(3)</sup>			
	Min	Typ	Max	Min	Max	Min	Condition	Max	Min	Typ	Max	Min	Typ	Max	
LVDS (Column I/Os)	2.375	2.5	2.625	100	—	0.05	$D_{MAX} \leq 500$ Mbps	1.80	247	—	600	1.125	1.25	1.375	
						0.55	$500 \text{ Mbps} \leq D_{MAX} \leq 700$ Mbps	1.80							
						1.05	$D_{MAX} > 700$ Mbps	1.55							
BLVDS (Row I/Os) <sup>(4)</sup>	2.375	2.5	2.625	100	—	—	—	—	—	—	—	—	—	—	—
BLVDS (Column I/Os) <sup>(4)</sup>	2.375	2.5	2.625	100	—	—	—	—	—	—	—	—	—	—	—
mini-LVDS (Row I/Os) <sup>(5)</sup>	2.375	2.5	2.625	—	—	—	—	—	300	—	600	1.0	1.2	1.4	
mini-LVDS (Column I/Os) <sup>(5)</sup>	2.375	2.5	2.625	—	—	—	—	—	300	—	600	1.0	1.2	1.4	
RSDS <sup>®</sup> (Row I/Os) <sup>(5)</sup>	2.375	2.5	2.625	—	—	—	—	—	100	200	600	0.5	1.2	1.5	
RSDS (Column I/Os) <sup>(5)</sup>	2.375	2.5	2.625	—	—	—	—	—	100	200	600	0.5	1.2	1.5	
PPDS (Row I/Os) <sup>(5)</sup>	2.375	2.5	2.625	—	—	—	—	—	100	200	600	0.5	1.2	1.4	
PPDS (Column I/Os) <sup>(5)</sup>	2.375	2.5	2.625	—	—	—	—	—	100	200	600	0.5	1.2	1.4	

**Notes to Table 1–20:**

- (1) For an explanation of terms used in Table 1–20, refer to “Glossary” on page 1–37.
- (2) V<sub>IN</sub> range:  $0 \text{ V} \leq V_{IN} \leq 1.85 \text{ V}$ .
- (3) R<sub>L</sub> range:  $90 \leq R_L \leq 110 \Omega$ .
- (4) There are no fixed V<sub>IN</sub>, V<sub>OD</sub>, and V<sub>OS</sub> specifications for BLVDS. They depend on the system topology.
- (5) The Mini-LVDS, RSDS, and PPDS standards are only supported at the output pins.
- (6) The LVPECL I/O standard is only supported on dedicated clock input pins. This I/O standard is not supported for output pins.

## Power Consumption

Use the following methods to estimate power for a design:

- the Excel-based EPE
- the Quartus® II PowerPlay power analyzer feature

The interactive Excel-based EPE is used prior to designing the device to get a magnitude estimate of the device power. The Quartus II PowerPlay power analyzer provides better quality estimates based on the specifics of the design after place-and-route is complete. The PowerPlay power analyzer can apply a combination of user-entered, simulation-derived, and estimated signal activities that, combined with detailed circuit models, can yield very accurate power estimates.



For more information about power estimation tools, refer to the *Early Power Estimator User Guide* and the *PowerPlay Power Analysis* chapter in volume 3 of the *Quartus II Handbook*.

## Switching Characteristics

This section provides performance characteristics of Cyclone IV core and periphery blocks for commercial grade devices.

These characteristics can be designated as Preliminary or Final.

- Preliminary characteristics are created using simulation results, process data, and other known parameters. The upper-right hand corner of these tables show the designation as “Preliminary”.
- Final numbers are based on actual silicon characterization and testing. The numbers reflect the actual performance of the device under worst-case silicon process, voltage, and junction temperature conditions. There are no designations on finalized tables.

## Transceiver Performance Specifications

Table 1-21 lists the Cyclone IV GX transceiver specifications.

**Table 1-21. Transceiver Specification for Cyclone IV GX Devices (Part 1 of 4)**

Symbol/ Description	Conditions	C6			C7, 17			C8			Unit
		Min	Typ	Max	Min	Typ	Max	Min	Typ	Max	
<b>Reference Clock</b>											
Supported I/O Standards	1.2 V PCML, 1.5 V PCML, 3.3 V PCML, Differential LVPECL, LVDS, HCSL										
Input frequency from REFCLK input pins	—	50	—	156.25	50	—	156.25	50	—	156.25	MHz
Spread-spectrum modulating clock frequency	Physical interface for PCI Express (PIPE) mode	30	—	33	30	—	33	30	—	33	kHz
Spread-spectrum downspread	PIPE mode	—	0 to -0.5%	—	—	0 to -0.5%	—	—	0 to -0.5%	—	—
Peak-to-peak differential input voltage	—	0.1	—	1.6	0.1	—	1.6	0.1	—	1.6	V
V <sub>ICM</sub> (AC coupled)	—	1100 ± 5%			1100 ± 5%			1100 ± 5%			mV
V <sub>ICM</sub> (DC coupled)	HCSL I/O standard for PCIe reference clock	250	—	550	250	—	550	250	—	550	mV
Transmitter REFCLK Phase Noise <sup>(1)</sup>	Frequency offset = 1 MHz – 8 MHz	—	—	-123	—	—	-123	—	—	-123	dBc/Hz
Transmitter REFCLK Total Jitter <sup>(1)</sup>		—	—	42.3	—	—	42.3	—	—	42.3	ps
R <sub>ref</sub>	—	—	2000 ± 1%	—	—	2000 ± 1%	—	—	2000 ± 1%	—	Ω
<b>Transceiver Clock</b>											
cal_blk_clk clock frequency	—	10	—	125	10	—	125	10	—	125	MHz
fixedclk clock frequency	PCIe Receiver Detect	—	125	—	—	125	—	—	125	—	MHz
reconfig_clk clock frequency	Dynamic reconfiguration clock frequency	2.5/ 37.5 <sup>(2)</sup>	—	50	2.5/ 37.5 <sup>(2)</sup>	—	50	2.5/ 37.5 <sup>(2)</sup>	—	50	MHz
Delta time between reconfig_clk	—	—	—	2	—	—	2	—	—	2	ms
Transceiver block minimum power-down pulse width	—	—	1	—	—	1	—	—	1	—	μs

Table 1–21. Transceiver Specification for Cyclone IV GX Devices (Part 2 of 4)

Symbol/ Description	Conditions	C6			C7, I7			C8			Unit
		Min	Typ	Max	Min	Typ	Max	Min	Typ	Max	
<b>Receiver</b>											
Supported I/O Standards	1.4 V PCML, 1.5 V PCML, 2.5 V PCML, LVPECL, LVDS										
Data rate (F324 and smaller package) <sup>(15)</sup>	—	600	—	2500	600	—	2500	600	—	2500	Mbps
Data rate (F484 and larger package) <sup>(15)</sup>	—	600	—	3125	600	—	3125	600	—	2500	Mbps
Absolute $V_{MAX}$ for a receiver pin <sup>(3)</sup>	—	—	—	1.6	—	—	1.6	—	—	1.6	V
Operational $V_{MAX}$ for a receiver pin	—	—	—	1.5	—	—	1.5	—	—	1.5	V
Absolute $V_{MIN}$ for a receiver pin	—	-0.4	—	—	-0.4	—	—	-0.4	—	—	V
Peak-to-peak differential input voltage $V_{ID}$ (diff p-p)	$V_{ICM} = 0.82$ V setting, Data Rate = 600 Mbps to 3.125 Gbps	0.1	—	2.7	0.1	—	2.7	0.1	—	2.7	V
$V_{ICM}$	$V_{ICM} = 0.82$ V setting	—	$820 \pm 10\%$	—	—	$820 \pm 10\%$	—	—	$820 \pm 10\%$	—	mV
Differential on-chip termination resistors	100- $\Omega$ setting	—	100	—	—	100	—	—	100	—	$\Omega$
	150- $\Omega$ setting	—	150	—	—	150	—	—	150	—	$\Omega$
Differential and common mode return loss	PIPE, Serial Rapid I/O SR, SATA, CPRI LV, SDI, XAUI	Compliant									—
Programmable ppm detector <sup>(4)</sup>	—	$\pm 62.5, 100, 125, 200, 250, 300$									ppm
Clock data recovery (CDR) ppm tolerance (without spread-spectrum clocking enabled)	—	—	—	$\pm 300$ <sup>(5)</sup> , $\pm 350$ <sup>(6), (7)</sup>	—	—	$\pm 300$ <sup>(5)</sup> , $\pm 350$ <sup>(6), (7)</sup>	—	—	$\pm 300$ <sup>(5)</sup> , $\pm 350$ <sup>(6), (7)</sup>	ppm
CDR ppm tolerance (with synchronous spread-spectrum clocking enabled) <sup>(8)</sup>	—	—	—	350 to -5350 <sup>(7), (9)</sup>	—	—	350 to -5350 <sup>(7), (9)</sup>	—	—	350 to -5350 <sup>(7), (9)</sup>	ppm
Run length	—	—	80	—	—	80	—	—	80	—	UI
Programmable equalization	No Equalization	—	—	1.5	—	—	1.5	—	—	1.5	dB
	Medium Low	—	—	4.5	—	—	4.5	—	—	4.5	dB
	Medium High	—	—	5.5	—	—	5.5	—	—	5.5	dB
	High	—	—	7	—	—	7	—	—	7	dB

**Table 1-21. Transceiver Specification for Cyclone IV GX Devices (Part 3 of 4)**

Symbol/ Description	Conditions	C6			C7, I7			C8			Unit
		Min	Typ	Max	Min	Typ	Max	Min	Typ	Max	
Signal detect/loss threshold	PIPE mode	65	—	175	65	—	175	65	—	175	mV
$t_{LTR}$ (10)	—	—	—	75	—	—	75	—	—	75	$\mu$ s
$t_{LTR-LTD\_Manual}$ (11)	—	15	—	—	15	—	—	15	—	—	$\mu$ s
$t_{LTD}$ (12)	—	0	100	4000	0	100	4000	0	100	4000	ns
$t_{LTD\_Manual}$ (13)	—	—	—	4000	—	—	4000	—	—	4000	ns
$t_{LTD\_Auto}$ (14)	—	—	—	4000	—	—	4000	—	—	4000	ns
Receiver buffer and CDR offset cancellation time (per channel)	—	—	—	17000	—	—	17000	—	—	17000	recon fig_clk cycles
Programmable DC gain	DC Gain Setting = 0	—	0	—	—	0	—	—	0	—	dB
	DC Gain Setting = 1	—	3	—	—	3	—	—	3	—	dB
	DC Gain Setting = 2	—	6	—	—	6	—	—	6	—	dB
<b>Transmitter</b>											
Supported I/O Standards	1.5 V PCML										
Data rate (F324 and smaller package)	—	600	—	2500	600	—	2500	600	—	2500	Mbps
Data rate (F484 and larger package)	—	600	—	3125	600	—	3125	600	—	2500	Mbps
$V_{OCM}$	0.65 V setting	—	650	—	—	650	—	—	650	—	mV
Differential on-chip termination resistors	100- $\Omega$ setting	—	100	—	—	100	—	—	100	—	$\Omega$
	150- $\Omega$ setting	—	150	—	—	150	—	—	150	—	$\Omega$
Differential and common mode return loss	PIPE, CPRI LV, Serial Rapid I/O SR, SDI, XAUI, SATA	Compliant									—
Rise time	—	50	—	200	50	—	200	50	—	200	ps
Fall time	—	50	—	200	50	—	200	50	—	200	ps
Intra-differential pair skew	—	—	—	15	—	—	15	—	—	15	ps
Intra-transceiver block skew	—	—	—	120	—	—	120	—	—	120	ps

**Table 1–21. Transceiver Specification for Cyclone IV GX Devices (Part 4 of 4)**

Symbol/ Description	Conditions	C6			C7, I7			C8			Unit
		Min	Typ	Max	Min	Typ	Max	Min	Typ	Max	
<b>PLD-Transceiver Interface</b>											
Interface speed (F324 and smaller package)	—	25	—	125	25	—	125	25	—	125	MHz
Interface speed (F484 and larger package)	—	25	—	156.25	25	—	156.25	25	—	156.25	MHz
Digital reset pulse width	—	Minimum is 2 parallel clock cycles									

**Notes to Table 1–21:**

- (1) This specification is valid for transmitter output jitter specification with a maximum total jitter value of 112 ps, typically for 3.125 Gbps SRIO and XAUI protocols.
- (2) The minimum `reconfig_clk` frequency is 2.5 MHz if the transceiver channel is configured in **Transmitter Only** mode. The minimum `reconfig_clk` frequency is 37.5 MHz if the transceiver channel is configured in **Receiver Only** or **Receiver and Transmitter** mode.
- (3) The device cannot tolerate prolonged operation at this absolute maximum.
- (4) The rate matcher supports only up to  $\pm 300$  parts per million (ppm).
- (5) Supported for the F169 and F324 device packages only.
- (6) Supported for the F484, F672, and F896 device packages only. Pending device characterization.
- (7) To support CDR ppm tolerance greater than  $\pm 300$  ppm, implement ppm detector in user logic and configure CDR to Manual Lock Mode.
- (8) Asynchronous spread-spectrum clocking is not supported.
- (9) For the EP4CGX30 (F484 package only), EP4CGX50, and EP4CGX75 devices, the CDR ppl tolerance is  $\pm 200$  ppm.
- (10) Time taken until `p11_locked` goes high after `p11_powerdown` deasserts.
- (11) Time that the CDR must be kept in lock-to-reference mode after `rx_analogreset` deasserts and before `rx_locktodata` is asserted in manual mode.
- (12) Time taken to recover valid data after the `rx_locktodata` signal is asserted in manual mode (Figure 1–2), or after `rx_freqlocked` signal goes high in automatic mode (Figure 1–3).
- (13) Time taken to recover valid data after the `rx_locktodata` signal is asserted in manual mode.
- (14) Time taken to recover valid data after the `rx_freqlocked` signal goes high in automatic mode.
- (15) To support data rates lower than the minimum specification through oversampling, use the CDR in LTR mode only.

Figure 1-2 shows the lock time parameters in manual mode.

 LTD = lock-to-data. LTR = lock-to-reference.

**Figure 1-2. Lock Time Parameters for Manual Mode**

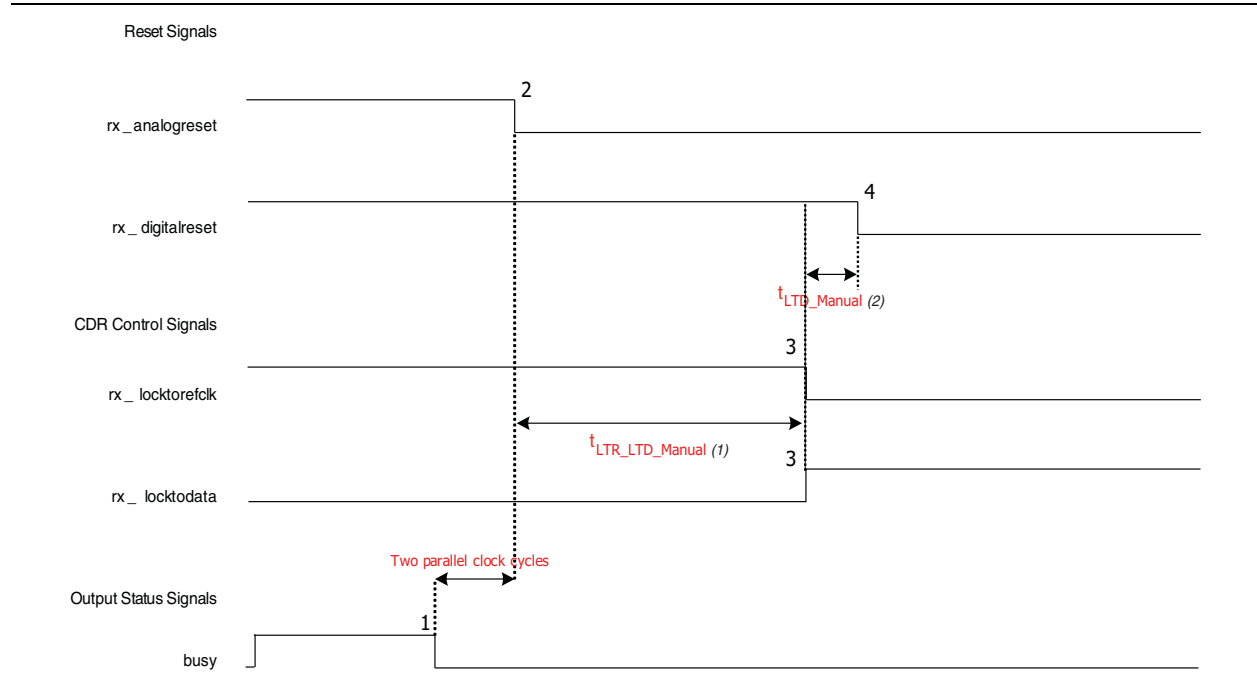

Figure 1-3 shows the lock time parameters in automatic mode.

**Figure 1-3. Lock Time Parameters for Automatic Mode**

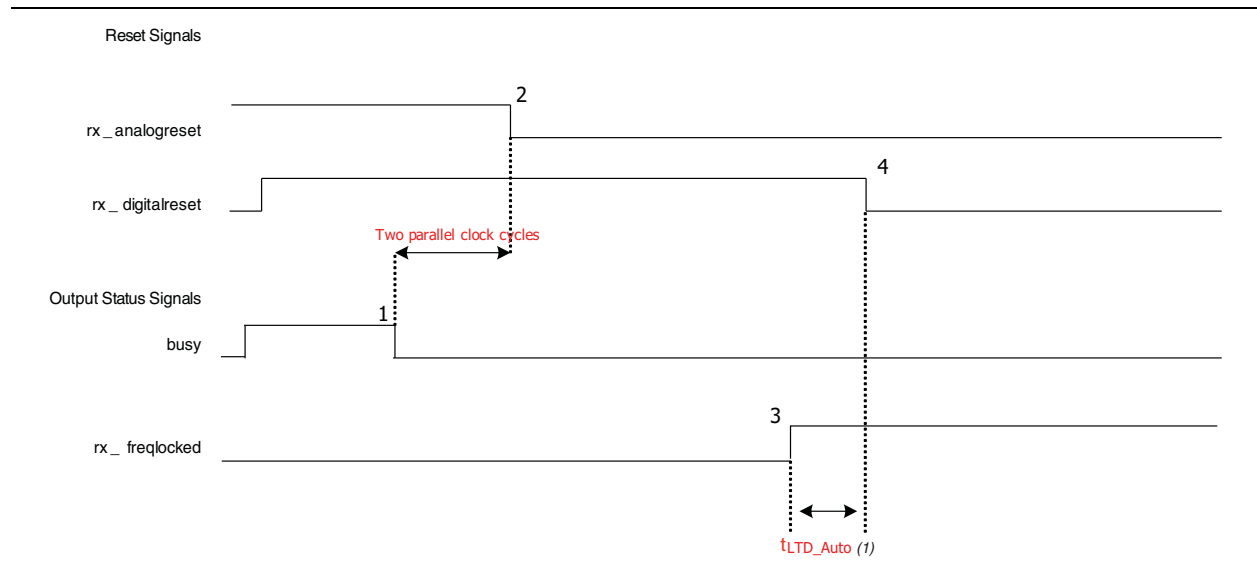

Figure 1-4 shows the differential receiver input waveform.

**Figure 1-4. Receiver Input Waveform**

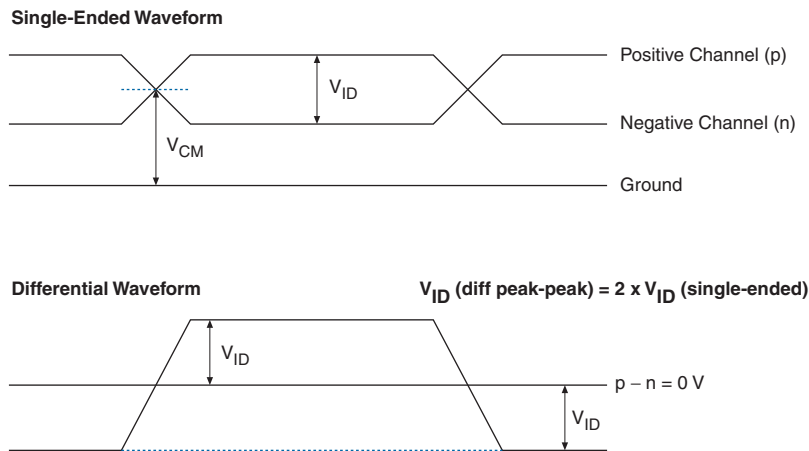

Figure 1-5 shows the transmitter output waveform.

**Figure 1-5. Transmitter Output Waveform**

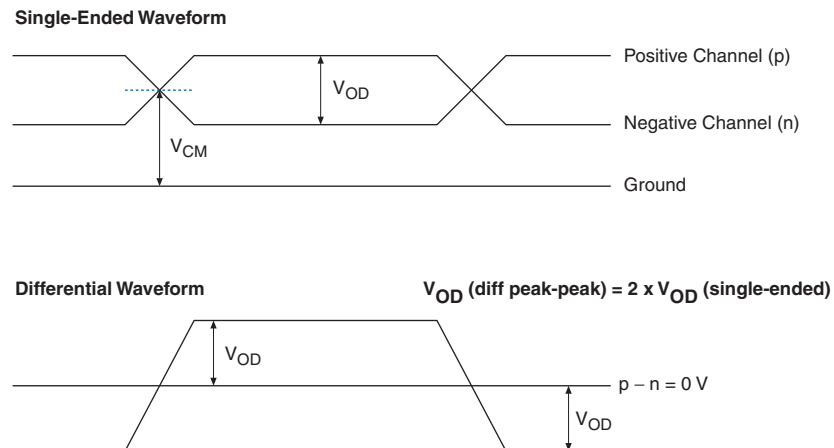

Table 1-22 lists the typical  $V_{OD}$  for Tx term that equals  $100 \Omega$ .

**Table 1-22. Typical  $V_{OD}$  Setting, Tx Term =  $100 \Omega$**

Symbol	$V_{OD}$ Setting (mV)					
	1	2	3	4 (1)	5	6
$V_{OD}$ differential peak to peak typical (mV)	400	600	800	900	1000	1200

**Note to Table 1-22:**

(1) This setting is required for compliance with the PCIe protocol.

Table 1-23 lists the Cyclone IV GX transceiver block AC specifications.

**Table 1-23. Transceiver Block AC Specification for Cyclone IV GX Devices <sup>(1), (2)</sup>**

Symbol/ Description	Conditions	C6			C7, I7			C8			Unit
		Min	Typ	Max	Min	Typ	Max	Min	Typ	Max	
<b>PCIe Transmit Jitter Generation <sup>(3)</sup></b>											
Total jitter at 2.5 Gbps (Gen1)	Compliance pattern	—	—	0.25	—	—	0.25	—	—	0.25	UI
<b>PCIe Receiver Jitter Tolerance <sup>(3)</sup></b>											
Total jitter at 2.5 Gbps (Gen1)	Compliance pattern	> 0.6			> 0.6			> 0.6			UI
<b>GIGE Transmit Jitter Generation <sup>(4)</sup></b>											
Deterministic jitter (peak-to-peak)	Pattern = CRPAT	—	—	0.14	—	—	0.14	—	—	0.14	UI
Total jitter (peak-to-peak)	Pattern = CRPAT	—	—	0.279	—	—	0.279	—	—	0.279	UI
<b>GIGE Receiver Jitter Tolerance <sup>(4)</sup></b>											
Deterministic jitter tolerance (peak-to-peak)	Pattern = CJPAT	> 0.4			> 0.4			> 0.4			UI
Combined deterministic and random jitter tolerance (peak-to-peak)	Pattern = CJPAT	> 0.66			> 0.66			> 0.66			UI

**Notes to Table 1-23:**

- (1) Dedicated `refclk` pins were used to drive the input reference clocks.
- (2) The jitter numbers specified are valid for the stated conditions only.
- (3) The jitter numbers for PIPE are compliant to the PCIe Base Specification 2.0.
- (4) The jitter numbers for GIGE are compliant to the IEEE802.3-2002 Specification.

## Core Performance Specifications

The following sections describe the clock tree specifications, PLLs, embedded multiplier, memory block, and configuration specifications for Cyclone IV Devices.

### Clock Tree Specifications

Table 1-24 lists the clock tree specifications for Cyclone IV devices.

**Table 1-24. Clock Tree Performance for Cyclone IV Devices (Part 1 of 2)**

Device	Performance								Unit
	C6	C7	C8	C8L <sup>(1)</sup>	C9L <sup>(1)</sup>	I7	I8L <sup>(1)</sup>	A7	
EP4CE6	500	437.5	402	362	265	437.5	362	402	MHz
EP4CE10	500	437.5	402	362	265	437.5	362	402	MHz
EP4CE15	500	437.5	402	362	265	437.5	362	402	MHz
EP4CE22	500	437.5	402	362	265	437.5	362	402	MHz
EP4CE30	500	437.5	402	362	265	437.5	362	402	MHz
EP4CE40	500	437.5	402	362	265	437.5	362	402	MHz

**Table 1–24. Clock Tree Performance for Cyclone IV Devices (Part 2 of 2)**

Device	Performance								Unit
	C6	C7	C8	C8L <sup>(1)</sup>	C9L <sup>(1)</sup>	I7	I8L <sup>(1)</sup>	A7	
EP4CE55	500	437.5	402	362	265	437.5	362	—	MHz
EP4CE75	500	437.5	402	362	265	437.5	362	—	MHz
EP4CE115	—	437.5	402	362	265	437.5	362	—	MHz
EP4CGX15	500	437.5	402	—	—	437.5	—	—	MHz
EP4CGX22	500	437.5	402	—	—	437.5	—	—	MHz
EP4CGX30	500	437.5	402	—	—	437.5	—	—	MHz
EP4CGX50	500	437.5	402	—	—	437.5	—	—	MHz
EP4CGX75	500	437.5	402	—	—	437.5	—	—	MHz
EP4CGX110	500	437.5	402	—	—	437.5	—	—	MHz
EP4CGX150	500	437.5	402	—	—	437.5	—	—	MHz

**Note to Table 1–24:**

(1) Cyclone IV E 1.0 V core voltage devices only support C8L, C9L, and I8L speed grades.

## PLL Specifications

Table 1–25 lists the PLL specifications for Cyclone IV devices when operating in the commercial junction temperature range (0°C to 85°C), the industrial junction temperature range (–40°C to 100°C), the extended industrial junction temperature range (–40°C to 125°C), and the automotive junction temperature range (–40°C to 125°C). For more information about the PLL block, refer to “Glossary” on page 1–37.

**Table 1–25. PLL Specifications for Cyclone IV Devices <sup>(1), (2)</sup> (Part 1 of 2)**

Symbol	Parameter	Min	Typ	Max	Unit
$f_{IN}$ <sup>(3)</sup>	Input clock frequency (–6, –7, –8 speed grades)	5	—	472.5	MHz
	Input clock frequency (–8L speed grade)	5	—	362	MHz
	Input clock frequency (–9L speed grade)	5	—	265	MHz
$f_{INPFD}$	PFD input frequency	5	—	325	MHz
$f_{VCO}$ <sup>(4)</sup>	PLL internal VCO operating range	600	—	1300	MHz
$f_{INDUTY}$	Input clock duty cycle	40	—	60	%
$t_{INJITTER\_CCJ}$ <sup>(5)</sup>	Input clock cycle-to-cycle jitter $F_{REF} \geq 100$ MHz	—	—	0.15	UI
	$F_{REF} < 100$ MHz	—	—	±750	ps
$f_{OUT\_EXT}$ (external clock output) <sup>(3)</sup>	PLL output frequency	—	—	472.5	MHz
$f_{OUT}$ (to global clock)	PLL output frequency (–6 speed grade)	—	—	472.5	MHz
	PLL output frequency (–7 speed grade)	—	—	450	MHz
	PLL output frequency (–8 speed grade)	—	—	402.5	MHz
	PLL output frequency (–8L speed grade)	—	—	362	MHz
	PLL output frequency (–9L speed grade)	—	—	265	MHz
$t_{OUTDUTY}$	Duty cycle for external clock output (when set to 50%)	45	50	55	%
$t_{LOCK}$	Time required to lock from end of device configuration	—	—	1	ms

**Table 1–25. PLL Specifications for Cyclone IV Devices <sup>(1), (2)</sup> (Part 2 of 2)**

Symbol	Parameter	Min	Typ	Max	Unit
$t_{DLOCK}$	Time required to lock dynamically (after switchover, reconfiguring any non-post-scale counters/delays or <code>areset</code> is deasserted)	—	—	1	ms
$t_{OUTJITTER\_PERIOD\_DEDCLK}$ <sup>(6)</sup>	$F_{OUT} \geq 100$ MHz	—	—	300	ps
	$F_{OUT} < 100$ MHz	—	—	30	mUI
$t_{OUTJITTER\_CCJ\_DEDCLK}$ <sup>(6)</sup>	Dedicated clock output cycle-to-cycle jitter $F_{OUT} \geq 100$ MHz	—	—	300	ps
	$F_{OUT} < 100$ MHz	—	—	30	mUI
$t_{OUTJITTER\_PERIOD\_IO}$ <sup>(6)</sup>	Regular I/O period jitter $F_{OUT} \geq 100$ MHz	—	—	650	ps
	$F_{OUT} < 100$ MHz	—	—	75	mUI
$t_{OUTJITTER\_CCJ\_IO}$ <sup>(6)</sup>	Regular I/O cycle-to-cycle jitter $F_{OUT} \geq 100$ MHz	—	—	650	ps
	$F_{OUT} < 100$ MHz	—	—	75	mUI
$t_{PLL\_PSERR}$	Accuracy of PLL phase shift	—	—	$\pm 50$	ps
$t_{ARESET}$	Minimum pulse width on <code>areset</code> signal.	10	—	—	ns
$t_{CONFIGPLL}$	Time required to reconfigure scan chains for PLLs	—	3.5 <sup>(7)</sup>	—	SCANCLK cycles
$f_{SCANCLK}$	<code>scanclk</code> frequency	—	—	100	MHz
$t_{CASC\_OUTJITTER\_PERIOD\_DEDCLK}$ <sup>(8), (9)</sup>	Period jitter for dedicated clock output in cascaded PLLs ( $F_{OUT} \geq 100$ MHz)	—	—	425	ps
	Period jitter for dedicated clock output in cascaded PLLs ( $F_{OUT} < 100$ MHz)	—	—	42.5	mUI

**Notes to Table 1–25:**

- (1) This table is applicable for general purpose PLLs and multipurpose PLLs.
- (2) You must connect  $V_{CCD\_PLL}$  to  $V_{CCINT}$  through the decoupling capacitor and ferrite bead.
- (3) This parameter is limited in the Quartus II software by the I/O maximum frequency. The maximum I/O frequency is different for each I/O standard.
- (4) The  $V_{CO}$  frequency reported by the Quartus II software in the PLL Summary section of the compilation report takes into consideration the  $V_{CO}$  post-scale counter K value. Therefore, if the counter K has a value of 2, the frequency reported can be lower than the  $f_{VCO}$  specification.
- (5) A high input jitter directly affects the PLL output jitter. To have low PLL output clock jitter, you must provide a clean clock source that is less than 200 ps.
- (6) Peak-to-peak jitter with a probability level of  $10^{-12}$  (14 sigma, 99.9999999974404% confidence level). The output jitter specification applies to the intrinsic jitter of the PLL when an input jitter of 30 ps is applied.
- (7) With 100-MHz `scanclk` frequency.
- (8) The cascaded PLLs specification is applicable only with the following conditions:
  - Upstream PLL— $0.59 \text{ MHz} \leq \text{Upstream PLL bandwidth} < 1 \text{ MHz}$
  - Downstream PLL—Downstream PLL bandwidth  $> 2 \text{ MHz}$
- (9) PLL cascading is not supported for transceiver applications.

## Embedded Multiplier Specifications

Table 1-26 lists the embedded multiplier specifications for Cyclone IV devices.

**Table 1-26. Embedded Multiplier Specifications for Cyclone IV Devices**

Mode	Resources Used	Performance					Unit
	Number of Multipliers	C6	C7, I7, A7	C8	C8L, I8L	C9L	
9 × 9-bit multiplier	1	340	300	260	240	175	MHz
18 × 18-bit multiplier	1	287	250	200	185	135	MHz

## Memory Block Specifications

Table 1-27 lists the M9K memory block specifications for Cyclone IV devices.

**Table 1-27. Memory Block Performance Specifications for Cyclone IV Devices**

Memory	Mode	Resources Used		Performance					Unit
		LEs	M9K Memory	C6	C7, I7, A7	C8	C8L, I8L	C9L	
M9K Block	FIFO 256 × 36	47	1	315	274	238	200	157	MHz
	Single-port 256 × 36	0	1	315	274	238	200	157	MHz
	Simple dual-port 256 × 36 CLK	0	1	315	274	238	200	157	MHz
	True dual port 512 × 18 single CLK	0	1	315	274	238	200	157	MHz

## Configuration and JTAG Specifications

Table 1-28 lists the configuration mode specifications for Cyclone IV devices.

**Table 1-28. Passive Configuration Mode Specifications for Cyclone IV Devices <sup>(1)</sup>**

Programming Mode	V <sub>CCINT</sub> Voltage Level (V)	DCLK f <sub>MAX</sub>	Unit
Passive Serial (PS)	1.0 <sup>(3)</sup>	66	MHz
	1.2	133	MHz
Fast Passive Parallel (FPP) <sup>(2)</sup>	1.0 <sup>(3)</sup>	66	MHz
	1.2 <sup>(4)</sup>	100	MHz

**Notes to Table 1-28:**

- (1) For more information about PS and FPP configuration timing parameters, refer to the *Configuration and Remote System Upgrades in Cyclone IV Devices* chapter.
- (2) FPP configuration mode supports all Cyclone IV E devices (except for E144 package devices) and EP4CGX50, EP4CGX75, EP4CGX110, and EP4CGX150 only.
- (3) V<sub>CCINT</sub> = 1.0 V is only supported for Cyclone IV E 1.0 V core voltage devices.
- (4) Cyclone IV E devices support 1.2 V V<sub>CCINT</sub>. Cyclone IV E 1.2 V core voltage devices support 133 MHz DCLK f<sub>MAX</sub> for EP4CE6, EP4CE10, EP4CE15, EP4CE22, EP4CE30, and EP4CE40 only.

Table 1–29 lists the active configuration mode specifications for Cyclone IV devices.

**Table 1–29. Active Configuration Mode Specifications for Cyclone IV Devices**

Programming Mode	DCLK Range	Typical DCLK	Unit
Active Parallel (AP) <sup>(1)</sup>	20 to 40	33	MHz
Active Serial (AS)	20 to 40	33	MHz

**Note to Table 1–29:**

- (1) AP configuration mode is only supported for Cyclone IV E devices.

Table 1–30 lists the JTAG timing parameters and values for Cyclone IV devices.

**Table 1–30. JTAG Timing Parameters for Cyclone IV Devices <sup>(1)</sup>**

Symbol	Parameter	Min	Max	Unit
$t_{JCP}$	TCK clock period	40	—	ns
$t_{JCH}$	TCK clock high time	19	—	ns
$t_{JCL}$	TCK clock low time	19	—	ns
$t_{JPSU\_TDI}$	JTAG port setup time for TDI	1	—	ns
$t_{JPSU\_TMS}$	JTAG port setup time for TMS	3	—	ns
$t_{JPH}$	JTAG port hold time	10	—	ns
$t_{JPCO}$	JTAG port clock to output <sup>(2), (3)</sup>	—	15	ns
$t_{JPZX}$	JTAG port high impedance to valid output <sup>(2), (3)</sup>	—	15	ns
$t_{JPXZ}$	JTAG port valid output to high impedance <sup>(2), (3)</sup>	—	15	ns
$t_{JSSU}$	Capture register setup time	5	—	ns
$t_{JSH}$	Capture register hold time	10	—	ns
$t_{JSCO}$	Update register clock to output	—	25	ns
$t_{JSZX}$	Update register high impedance to valid output	—	25	ns
$t_{JSXZ}$	Update register valid output to high impedance	—	25	ns

**Notes to Table 1–30:**

- (1) For more information about JTAG waveforms, refer to “JTAG Waveform” in “Glossary” on page 1–37.  
 (2) The specification is shown for 3.3-, 3.0-, and 2.5-V LVTTTL/LVCMOS operation of JTAG pins. For 1.8-V LVTTTL/LVCMOS and 1.5-V LVCMOS, the output time specification is 16 ns.  
 (3) For EP4CGX22, EP4CGX30 (F324 and smaller package), EP4CGX110, and EP4CGX150 devices, the output time specification for 3.3-, 3.0-, and 2.5-V LVTTTL/LVCMOS operation of JTAG pins is 16 ns. For 1.8-V LVTTTL/LVCMOS and 1.5-V LVCMOS, the output time specification is 18 ns.

## Periphery Performance

This section describes periphery performance, including high-speed I/O and external memory interface.

I/O performance supports several system interfaces, such as the high-speed I/O interface, external memory interface, and the PCI/PCI-X bus interface. I/Os using the SSTL-18 Class I termination standard can achieve up to the stated DDR2 SDRAM interfacing speeds. I/Os using general-purpose I/O standards such as 3.3-, 3.0-, 2.5-, 1.8-, or 1.5-LVTTTL/LVCMOS are capable of a typical 200 MHz interfacing frequency with a 10 pF load.

 For more information about the supported maximum clock rate, device and pin planning, IP implementation, and device termination, refer to [Section III: System Performance Specifications](#) of the *External Memory Interfaces Handbook*.

 Actual achievable frequency depends on design- and system-specific factors. Perform HSPICE/IBIS simulations based on your specific design and system setup to determine the maximum achievable frequency in your system.

## High-Speed I/O Specifications

Table 1-31 through Table 1-36 list the high-speed I/O timing for Cyclone IV devices. For definitions of high-speed timing specifications, refer to “[Glossary](#)” on page 1-37.

**Table 1-31. RSDS Transmitter Timing Specifications for Cyclone IV Devices <sup>(1), (2), (4)</sup> (Part 1 of 2)**

Symbol	Modes	C6			C7, I7			C8, A7			C8L, I8L			C9L			Unit
		Min	Typ	Max	Min	Typ	Max	Min	Typ	Max	Min	Typ	Max	Min	Typ	Max	
$f_{\text{HSCLK}}$ (input clock frequency)	×10	5	—	180	5	—	155.5	5	—	155.5	5	—	155.5	5	—	132.5	MHz
	×8	5	—	180	5	—	155.5	5	—	155.5	5	—	155.5	5	—	132.5	MHz
	×7	5	—	180	5	—	155.5	5	—	155.5	5	—	155.5	5	—	132.5	MHz
	×4	5	—	180	5	—	155.5	5	—	155.5	5	—	155.5	5	—	132.5	MHz
	×2	5	—	180	5	—	155.5	5	—	155.5	5	—	155.5	5	—	132.5	MHz
	×1	5	—	360	5	—	311	5	—	311	5	—	311	5	—	265	MHz
Device operation in Mbps	×10	100	—	360	100	—	311	100	—	311	100	—	311	100	—	265	Mbps
	×8	80	—	360	80	—	311	80	—	311	80	—	311	80	—	265	Mbps
	×7	70	—	360	70	—	311	70	—	311	70	—	311	70	—	265	Mbps
	×4	40	—	360	40	—	311	40	—	311	40	—	311	40	—	265	Mbps
	×2	20	—	360	20	—	311	20	—	311	20	—	311	20	—	265	Mbps
	×1	10	—	360	10	—	311	10	—	311	10	—	311	10	—	265	Mbps
$t_{\text{DUTY}}$	—	45	—	55	45	—	55	45	—	55	45	—	55	45	—	55	%
Transmitter channel-to-channel skew (TCCS)	—	—	—	200	—	—	200	—	—	200	—	—	200	—	—	200	ps
Output jitter (peak to peak)	—	—	—	500	—	—	500	—	—	550	—	—	600	—	—	700	ps
$t_{\text{RISE}}$	20 – 80%, $C_{\text{LOAD}} = 5 \text{ pF}$	—	500	—	—	500	—	—	500	—	—	500	—	—	500	—	ps
$t_{\text{FALL}}$	20 – 80%, $C_{\text{LOAD}} = 5 \text{ pF}$	—	500	—	—	500	—	—	500	—	—	500	—	—	500	—	ps

**Table 1-31. RSDS Transmitter Timing Specifications for Cyclone IV Devices <sup>(1), (2), (4)</sup> (Part 2 of 2)**

Symbol	Modes	C6			C7, I7			C8, A7			C8L, I8L			C9L			Unit
		Min	Typ	Max	Min	Typ	Max	Min	Typ	Max	Min	Typ	Max	Min	Typ	Max	
$t_{LOCK}^{(3)}$	—	—	—	1	—	—	1	—	—	1	—	—	1	—	—	1	ms

**Notes to Table 1-31:**

- (1) Applicable for true RSDS and emulated RSDS\_E\_3R transmitter.
- (2) Cyclone IV E devices—true RSDS transmitter is only supported at the output pin of Row I/O Banks 1, 2, 5, and 6. Emulated RSDS transmitter is supported at the output pin of all I/O Banks.  
Cyclone IV GX devices—true RSDS transmitter is only supported at the output pin of Row I/O Banks 5 and 6. Emulated RSDS transmitter is supported at the output pin of I/O Banks 3, 4, 5, 6, 7, 8, and 9.
- (3)  $t_{LOCK}$  is the time required for the PLL to lock from the end-of-device configuration.
- (4) Cyclone IV E 1.0 V core voltage devices only support C8L, C9L, and I8L speed grades. Cyclone IV E 1.2 V core voltage devices only support C6, C7, C8, I7, and A7 speed grades. Cyclone IV GX devices only support C6, C7, C8, and I7 speed grades.

**Table 1-32. Emulated RSDS\_E\_1R Transmitter Timing Specifications for Cyclone IV Devices <sup>(1), (3)</sup> (Part 1 of 2)**

Symbol	Modes	C6			C7, I7			C8, A7			C8L, I8L			C9L			Unit
		Min	Typ	Max	Min	Typ	Max	Min	Typ	Max	Min	Typ	Max	Min	Typ	Max	
$f_{HSCLK}$ (input clock frequency)	×10	5	—	85	5	—	85	5	—	85	5	—	85	5	—	72.5	MHz
	×8	5	—	85	5	—	85	5	—	85	5	—	85	5	—	72.5	MHz
	×7	5	—	85	5	—	85	5	—	85	5	—	85	5	—	72.5	MHz
	×4	5	—	85	5	—	85	5	—	85	5	—	85	5	—	72.5	MHz
	×2	5	—	85	5	—	85	5	—	85	5	—	85	5	—	72.5	MHz
	×1	5	—	170	5	—	170	5	—	170	5	—	170	5	—	145	MHz
Device operation in Mbps	×10	100	—	170	100	—	170	100	—	170	100	—	170	100	—	145	Mbps
	×8	80	—	170	80	—	170	80	—	170	80	—	170	80	—	145	Mbps
	×7	70	—	170	70	—	170	70	—	170	70	—	170	70	—	145	Mbps
	×4	40	—	170	40	—	170	40	—	170	40	—	170	40	—	145	Mbps
	×2	20	—	170	20	—	170	20	—	170	20	—	170	20	—	145	Mbps
	×1	10	—	170	10	—	170	10	—	170	10	—	170	10	—	145	Mbps
$t_{DUTY}$	—	45	—	55	45	—	55	45	—	55	45	—	55	45	—	55	%
TCCS	—	—	—	200	—	—	200	—	—	200	—	—	200	—	—	200	ps
Output jitter (peak to peak)	—	—	—	500	—	—	500	—	—	550	—	—	600	—	—	700	ps
$t_{RISE}$	20 – 80%, $C_{LOAD} = 5\text{ pF}$	—	500	—	—	500	—	—	500	—	—	500	—	—	500	—	ps
$t_{FALL}$	20 – 80%, $C_{LOAD} = 5\text{ pF}$	—	500	—	—	500	—	—	500	—	—	500	—	—	500	—	ps

**Table 1-32. Emulated RSDS\_E\_1R Transmitter Timing Specifications for Cyclone IV Devices <sup>(1), (3)</sup> (Part 2 of 2)**

Symbol	Modes	C6			C7, I7			C8, A7			C8L, I8L			C9L			Unit
		Min	Typ	Max	Min	Typ	Max	Min	Typ	Max	Min	Typ	Max	Min	Typ	Max	
$t_{\text{LOCK}}$ <sup>(2)</sup>	—	—	—	1	—	—	1	—	—	1	—	—	1	—	—	1	ms

**Notes to Table 1-32:**

- (1) Emulated RSDS\_E\_1R transmitter is supported at the output pin of all I/O Banks of Cyclone IV E devices and I/O Banks 3, 4, 5, 6, 7, 8, and 9 of Cyclone IV GX devices.
- (2)  $t_{\text{LOCK}}$  is the time required for the PLL to lock from the end-of-device configuration.
- (3) Cyclone IV E 1.0 V core voltage devices only support C8L, C9L, and I8L speed grades. Cyclone IV E 1.2 V core voltage devices only support C6, C7, C8, I7, and A7 speed grades. Cyclone IV GX devices only support C6, C7, C8, and I7 speed grades.

**Table 1-33. Mini-LVDS Transmitter Timing Specifications for Cyclone IV Devices <sup>(1), (2), (4)</sup>**

Symbol	Modes	C6			C7, I7			C8, A7			C8L, I8L			C9L			Unit
		Min	Typ	Max	Min	Typ	Max	Min	Typ	Max	Min	Typ	Max	Min	Typ	Max	
$f_{\text{HCLK}}$ (input clock frequency)	×10	5	—	200	5	—	155.5	5	—	155.5	5	—	155.5	5	—	132.5	MHz
	×8	5	—	200	5	—	155.5	5	—	155.5	5	—	155.5	5	—	132.5	MHz
	×7	5	—	200	5	—	155.5	5	—	155.5	5	—	155.5	5	—	132.5	MHz
	×4	5	—	200	5	—	155.5	5	—	155.5	5	—	155.5	5	—	132.5	MHz
	×2	5	—	200	5	—	155.5	5	—	155.5	5	—	155.5	5	—	132.5	MHz
	×1	5	—	400	5	—	311	5	—	311	5	—	311	5	—	265	MHz
Device operation in Mbps	×10	100	—	400	100	—	311	100	—	311	100	—	311	100	—	265	Mbps
	×8	80	—	400	80	—	311	80	—	311	80	—	311	80	—	265	Mbps
	×7	70	—	400	70	—	311	70	—	311	70	—	311	70	—	265	Mbps
	×4	40	—	400	40	—	311	40	—	311	40	—	311	40	—	265	Mbps
	×2	20	—	400	20	—	311	20	—	311	20	—	311	20	—	265	Mbps
	×1	10	—	400	10	—	311	10	—	311	10	—	311	10	—	265	Mbps
$t_{\text{DUTY}}$	—	45	—	55	45	—	55	45	—	55	45	—	55	45	—	55	%
TCCS	—	—	—	200	—	—	200	—	—	200	—	—	200	—	—	200	ps
Output jitter (peak to peak)	—	—	—	500	—	—	500	—	—	550	—	—	600	—	—	700	ps
$t_{\text{RISE}}$	20 – 80%, $C_{\text{LOAD}} = 5$ pF	—	500	—	—	500	—	—	500	—	—	500	—	—	500	—	ps
$t_{\text{FALL}}$	20 – 80%, $C_{\text{LOAD}} = 5$ pF	—	500	—	—	500	—	—	500	—	—	500	—	—	500	—	ps
$t_{\text{LOCK}}$ <sup>(3)</sup>	—	—	—	1	—	—	1	—	—	1	—	—	1	—	—	1	ms

**Notes to Table 1-33:**

- (1) Applicable for true and emulated mini-LVDS transmitter.
- (2) Cyclone IV E—true mini-LVDS transmitter is only supported at the output pin of Row I/O Banks 1, 2, 5, and 6. Emulated mini-LVDS transmitter is supported at the output pin of all I/O banks.  
Cyclone IV GX—true mini-LVDS transmitter is only supported at the output pin of Row I/O Banks 5 and 6. Emulated mini-LVDS transmitter is supported at the output pin of I/O Banks 3, 4, 5, 6, 7, 8, and 9.
- (3)  $t_{\text{LOCK}}$  is the time required for the PLL to lock from the end-of-device configuration.
- (4) Cyclone IV E 1.0 V core voltage devices only support C8L, C9L, and I8L speed grades. Cyclone IV E 1.2 V core voltage devices only support C6, C7, C8, I7, and A7 speed grades. Cyclone IV GX devices only support C6, C7, C8, and I7 speed grades.

**Table 1–34. True LVDS Transmitter Timing Specifications for Cyclone IV Devices <sup>(1), (3)</sup>**

Symbol	Modes	C6		C7, I7		C8, A7		C8L, I8L		C9L		Unit
		Min	Max	Min	Max	Min	Max	Min	Max	Min	Max	
f <sub>HSCLK</sub> (input clock frequency)	×10	5	420	5	370	5	320	5	320	5	250	MHz
	×8	5	420	5	370	5	320	5	320	5	250	MHz
	×7	5	420	5	370	5	320	5	320	5	250	MHz
	×4	5	420	5	370	5	320	5	320	5	250	MHz
	×2	5	420	5	370	5	320	5	320	5	250	MHz
	×1	5	420	5	402.5	5	402.5	5	362	5	265	MHz
HSIODR	×10	100	840	100	740	100	640	100	640	100	500	Mbps
	×8	80	840	80	740	80	640	80	640	80	500	Mbps
	×7	70	840	70	740	70	640	70	640	70	500	Mbps
	×4	40	840	40	740	40	640	40	640	40	500	Mbps
	×2	20	840	20	740	20	640	20	640	20	500	Mbps
	×1	10	420	10	402.5	10	402.5	10	362	10	265	Mbps
t <sub>DUTY</sub>	—	45	55	45	55	45	55	45	55	45	55	%
TCCS	—	—	200	—	200	—	200	—	200	—	200	ps
Output jitter (peak to peak)	—	—	500	—	500	—	550	—	600	—	700	ps
t <sub>LOCK</sub> <sup>(2)</sup>	—	—	1	—	1	—	1	—	1	—	1	ms

**Notes to Table 1–34:**

- (1) Cyclone IV E—true LVDS transmitter is only supported at the output pin of Row I/O Banks 1, 2, 5, and 6. Cyclone IV GX—true LVDS transmitter is only supported at the output pin of Row I/O Banks 5 and 6.
- (2) t<sub>LOCK</sub> is the time required for the PLL to lock from the end-of-device configuration.
- (3) Cyclone IV E 1.0 V core voltage devices only support C8L, C9L, and I8L speed grades. Cyclone IV E 1.2 V core voltage devices only support C6, C7, C8, I7, and A7 speed grades. Cyclone IV GX devices only support C6, C7, C8, and I7 speed grades.

**Table 1–35. Emulated LVDS Transmitter Timing Specifications for Cyclone IV Devices <sup>(1), (3)</sup> (Part 1 of 2)**

Symbol	Modes	C6		C7, I7		C8, A7		C8L, I8L		C9L		Unit
		Min	Max	Min	Max	Min	Max	Min	Max	Min	Max	
f <sub>HSCLK</sub> (input clock frequency)	×10	5	320	5	320	5	275	5	275	5	250	MHz
	×8	5	320	5	320	5	275	5	275	5	250	MHz
	×7	5	320	5	320	5	275	5	275	5	250	MHz
	×4	5	320	5	320	5	275	5	275	5	250	MHz
	×2	5	320	5	320	5	275	5	275	5	250	MHz
	×1	5	402.5	5	402.5	5	402.5	5	362	5	265	MHz
HSIODR	×10	100	640	100	640	100	550	100	550	100	500	Mbps
	×8	80	640	80	640	80	550	80	550	80	500	Mbps
	×7	70	640	70	640	70	550	70	550	70	500	Mbps
	×4	40	640	40	640	40	550	40	550	40	500	Mbps
	×2	20	640	20	640	20	550	20	550	20	500	Mbps
	×1	10	402.5	10	402.5	10	402.5	10	362	10	265	Mbps

**Table 1-35. Emulated LVDS Transmitter Timing Specifications for Cyclone IV Devices <sup>(1), (3)</sup> (Part 2 of 2)**

Symbol	Modes	C6		C7, I7		C8, A7		C8L, I8L		C9L		Unit
		Min	Max	Min	Max	Min	Max	Min	Max	Min	Max	
t <sub>DUTY</sub>	—	45	55	45	55	45	55	45	55	45	55	%
TCCS	—	—	200	—	200	—	200	—	200	—	200	ps
Output jitter (peak to peak)	—	—	500	—	500	—	550	—	600	—	700	ps
t <sub>LOCK</sub> <sup>(2)</sup>	—	—	1	—	1	—	1	—	1	—	1	ms

**Notes to Table 1-35:**

- (1) Cyclone IV E—emulated LVDS transmitter is supported at the output pin of all I/O Banks.  
Cyclone IV GX—emulated LVDS transmitter is supported at the output pin of I/O Banks 3, 4, 5, 6, 7, 8, and 9.
- (2) t<sub>LOCK</sub> is the time required for the PLL to lock from the end-of-device configuration.
- (3) Cyclone IV E 1.0 V core voltage devices only support C8L, C9L, and I8L speed grades. Cyclone IV E 1.2 V core voltage devices only support C6, C7, C8, I7, and A7 speed grades. Cyclone IV GX devices only support C6, C7, C8, and I7 speed grades.

**Table 1-36. LVDS Receiver Timing Specifications for Cyclone IV Devices <sup>(1), (3)</sup>**

Symbol	Modes	C6		C7, I7		C8, A7		C8L, I8L		C9L		Unit
		Min	Max	Min	Max	Min	Max	Min	Max	Min	Max	
f <sub>HCLK</sub> (input clock frequency)	×10	10	437.5	10	370	10	320	10	320	10	250	MHz
	×8	10	437.5	10	370	10	320	10	320	10	250	MHz
	×7	10	437.5	10	370	10	320	10	320	10	250	MHz
	×4	10	437.5	10	370	10	320	10	320	10	250	MHz
	×2	10	437.5	10	370	10	320	10	320	10	250	MHz
	×1	10	437.5	10	402.5	10	402.5	10	362	10	265	MHz
HSIODR	×10	100	875	100	740	100	640	100	640	100	500	Mbps
	×8	80	875	80	740	80	640	80	640	80	500	Mbps
	×7	70	875	70	740	70	640	70	640	70	500	Mbps
	×4	40	875	40	740	40	640	40	640	40	500	Mbps
	×2	20	875	20	740	20	640	20	640	20	500	Mbps
	×1	10	437.5	10	402.5	10	402.5	10	362	10	265	Mbps
SW	—	—	400	—	400	—	400	—	550	—	640	ps
Input jitter tolerance	—	—	500	—	500	—	550	—	600	—	700	ps
t <sub>LOCK</sub> <sup>(2)</sup>	—	—	1	—	1	—	1	—	1	—	1	ms

**Notes to Table 1-36:**

- (1) Cyclone IV E—LVDS receiver is supported at all I/O Banks.  
Cyclone IV GX—LVDS receiver is supported at I/O Banks 3, 4, 5, 6, 7, 8, and 9.
- (2) t<sub>LOCK</sub> is the time required for the PLL to lock from the end-of-device configuration.
- (3) Cyclone IV E 1.0 V core voltage devices only support C8L, C9L, and I8L speed grades. Cyclone IV E 1.2 V core voltage devices only support C6, C7, C8, I7, and A7 speed grades. Cyclone IV GX devices only support C6, C7, C8, and I7 speed grades.

## External Memory Interface Specifications

The external memory interfaces for Cyclone IV devices are auto-calibrating and easy to implement.

 For more information about the supported maximum clock rate, device and pin planning, IP implementation, and device termination, refer to *Section III: System Performance Specifications* of the *External Memory Interface Handbook*.

Table 1-37 lists the memory output clock jitter specifications for Cyclone IV devices.

**Table 1-37. Memory Output Clock Jitter Specifications for Cyclone IV Devices <sup>(1), (2)</sup>**

Parameter	Symbol	Min	Max	Unit
Clock period jitter	$t_{JIT(per)}$	-125	125	ps
Cycle-to-cycle period jitter	$t_{JIT(cc)}$	-200	200	ps
Duty cycle jitter	$t_{JIT(duty)}$	-150	150	ps

**Notes to Table 1-37:**

- (1) Memory output clock jitter measurements are for 200 consecutive clock cycles, as specified in the JEDEC DDR2 standard.
- (2) The clock jitter specification applies to memory output clock pins generated using DDIO circuits clocked by a PLL output routed on a global clock (GCLK) network.

### Duty Cycle Distortion Specifications

Table 1-38 lists the worst case duty cycle distortion for Cyclone IV devices.

**Table 1-38. Duty Cycle Distortion on Cyclone IV Devices I/O Pins <sup>(1), (2), (3)</sup>**

Symbol	C6		C7, I7		C8, I8L, A7		C9L		Unit
	Min	Max	Min	Max	Min	Max	Min	Max	
Output Duty Cycle	45	55	45	55	45	55	45	55	%

**Notes to Table 1-38:**

- (1) The duty cycle distortion specification applies to clock outputs from the PLLs, global clock tree, and IOE driving the dedicated and general purpose I/O pins.
- (2) Cyclone IV devices meet the specified duty cycle distortion at the maximum output toggle rate for each combination of I/O standard and current strength.
- (3) Cyclone IV E 1.0 V core voltage devices only support C8L, C9L, and I8L speed grades. Cyclone IV E 1.2 V core voltage devices only support C6, C7, C8, I7, and A7 speed grades. Cyclone IV GX devices only support C6, C7, C8, and I7 speed grades.

### OCT Calibration Timing Specification

Table 1-39 lists the duration of calibration for series OCT with calibration at device power-up for Cyclone IV devices.

**Table 1-39. Timing Specification for Series OCT with Calibration at Device Power-Up for Cyclone IV Devices <sup>(1)</sup>**

Symbol	Description	Maximum	Units
$t_{OCTCAL}$	Duration of series OCT with calibration at device power-up	20	$\mu$ s

**Note to Table 1-39:**

- (1) OCT calibration takes place after device configuration and before entering user mode.

## IOE Programmable Delay

Table 1–40 and Table 1–41 list the IOE programmable delay for Cyclone IV E 1.0 V core voltage devices.

**Table 1–40. IOE Programmable Delay on Column Pins for Cyclone IV E 1.0 V Core Voltage Devices <sup>(1), (2)</sup>**

Parameter	Paths Affected	Number of Setting	Min Offset	Max Offset					Unit
				Fast Corner		Slow Corner			
				C8L	I8L	C8L	C9L	I8L	
Input delay from pin to internal cells	Pad to I/O dataout to core	7	0	2.054	1.924	3.387	4.017	3.411	ns
Input delay from pin to input register	Pad to I/O input register	8	0	2.010	1.875	3.341	4.252	3.367	ns
Delay from output register to output pin	I/O output register to pad	2	0	0.641	0.631	1.111	1.377	1.124	ns
Input delay from dual-purpose clock pin to fan-out destinations	Pad to global clock network	12	0	0.971	0.931	1.684	2.298	1.684	ns

**Notes to Table 1–40:**

- (1) The incremental values for the settings are generally linear. For the exact values for each setting, use the latest version of the Quartus II software.
- (2) The minimum and maximum offset timing numbers are in reference to setting **0** as available in the Quartus II software.

**Table 1–41. IOE Programmable Delay on Row Pins for Cyclone IV E 1.0 V Core Voltage Devices <sup>(1), (2)</sup>**

Parameter	Paths Affected	Number of Setting	Min Offset	Max Offset					Unit
				Fast Corner		Slow Corner			
				C8L	I8L	C8L	C9L	I8L	
Input delay from pin to internal cells	Pad to I/O dataout to core	7	0	2.057	1.921	3.389	4.146	3.412	ns
Input delay from pin to input register	Pad to I/O input register	8	0	2.059	1.919	3.420	4.374	3.441	ns
Delay from output register to output pin	I/O output register to pad	2	0	0.670	0.623	1.160	1.420	1.168	ns
Input delay from dual-purpose clock pin to fan-out destinations	Pad to global clock network	12	0	0.960	0.919	1.656	2.258	1.656	ns

**Notes to Table 1–41:**

- (1) The incremental values for the settings are generally linear. For the exact values for each setting, use the latest version of the Quartus II software.
- (2) The minimum and maximum offset timing numbers are in reference to setting **0** as available in the Quartus II software.

Table 1-42 and Table 1-43 list the IOE programmable delay for Cyclone IV E 1.2 V core voltage devices.

**Table 1-42. IOE Programmable Delay on Column Pins for Cyclone IV E 1.2 V Core Voltage Devices <sup>(1), (2)</sup>**

Parameter	Paths Affected	Number of Setting	Min Offset	Max Offset								Unit
				Fast Corner			Slow Corner					
				C6	I7	A7	C6	C7	C8	I7	A7	
Input delay from pin to internal cells	Pad to I/O dataout to core	7	0	1.314	1.211	1.211	2.177	2.340	2.433	2.388	2.508	ns
Input delay from pin to input register	Pad to I/O input register	8	0	1.307	1.203	1.203	2.19	2.387	2.540	2.430	2.545	ns
Delay from output register to output pin	I/O output register to pad	2	0	0.437	0.402	0.402	0.747	0.820	0.880	0.834	0.873	ns
Input delay from dual-purpose clock pin to fan-out destinations	Pad to global clock network	12	0	0.693	0.665	0.665	1.200	1.379	1.532	1.393	1.441	ns

**Notes to Table 1-42:**

- (1) The incremental values for the settings are generally linear. For the exact values for each setting, use the latest version of the Quartus II software.
- (2) The minimum and maximum offset timing numbers are in reference to setting **0** as available in the Quartus II software.

**Table 1-43. IOE Programmable Delay on Row Pins for Cyclone IV E 1.2 V Core Voltage Devices <sup>(1), (2)</sup>**

Parameter	Paths Affected	Number of Setting	Min Offset	Max Offset								Unit
				Fast Corner			Slow Corner					
				C6	I7	A7	C6	C7	C8	I7	A7	
Input delay from pin to internal cells	Pad to I/O dataout to core	7	0	1.314	1.209	1.209	2.201	2.386	2.510	2.429	2.548	ns
Input delay from pin to input register	Pad to I/O input register	8	0	1.312	1.207	1.207	2.202	2.402	2.558	2.447	2.557	ns
Delay from output register to output pin	I/O output register to pad	2	0	0.458	0.419	0.419	0.783	0.861	0.924	0.875	0.915	ns
Input delay from dual-purpose clock pin to fan-out destinations	Pad to global clock network	12	0	0.686	0.657	0.657	1.185	1.360	1.506	1.376	1.422	ns

**Notes to Table 1-43:**

- (1) The incremental values for the settings are generally linear. For the exact values for each setting, use the latest version of the Quartus II software.
- (2) The minimum and maximum offset timing numbers are in reference to setting **0** as available in the Quartus II software.

Table 1-44 and Table 1-45 list the IOE programmable delay for Cyclone IV GX devices.

**Table 1-44. IOE Programmable Delay on Column Pins for Cyclone IV GX Devices <sup>(1), (2)</sup>**

Parameter	Paths Affected	Number of Settings	Min Offset	Max Offset						Unit
				Fast Corner		Slow Corner				
				C6	I7	C6	C7	C8	I7	
Input delay from pin to internal cells	Pad to I/O dataout to core	7	0	1.313	1.209	2.184	2.336	2.451	2.387	ns
Input delay from pin to input register	Pad to I/O input register	8	0	1.312	1.208	2.200	2.399	2.554	2.446	ns
Delay from output register to output pin	I/O output register to pad	2	0	0.438	0.404	0.751	0.825	0.886	0.839	ns
Input delay from dual-purpose clock pin to fan-out destinations	Pad to global clock network	12	0	0.713	0.682	1.228	1.41	1.566	1.424	ns

**Notes to Table 1-44:**

- (1) The incremental values for the settings are generally linear. For exact values of each setting, use the latest version of the Quartus II software.
- (2) The minimum and maximum offset timing numbers are in reference to setting **0** as available in the Quartus II software.

**Table 1-45. IOE Programmable Delay on Row Pins for Cyclone IV GX Devices <sup>(1), (2)</sup>**

Parameter	Paths Affected	Number of Settings	Min Offset	Max Offset						Unit
				Fast Corner		Slow Corner				
				C6	I7	C6	C7	C8	I7	
Input delay from pin to internal cells	Pad to I/O dataout to core	7	0	1.314	1.210	2.209	2.398	2.526	2.443	ns
Input delay from pin to input register	Pad to I/O input register	8	0	1.313	1.208	2.205	2.406	2.563	2.450	ns
Delay from output register to output pin	I/O output register to pad	2	0	0.461	0.421	0.789	0.869	0.933	0.884	ns
Input delay from dual-purpose clock pin to fan-out destinations	Pad to global clock network	12	0	0.712	0.682	1.225	1.407	1.562	1.421	ns

**Notes to Table 1-45:**

- (1) The incremental values for the settings are generally linear. For exact values of each setting, use the latest version of Quartus II software.
- (2) The minimum and maximum offset timing numbers are in reference to setting **0** as available in the Quartus II software.

## I/O Timing

Use the following methods to determine I/O timing:

- the Excel-based I/O Timing
- the Quartus II timing analyzer

The Excel-based I/O timing provides pin timing performance for each device density and speed grade. The data is typically used prior to designing the FPGA to get a timing budget estimation as part of the link timing analysis. The Quartus II timing analyzer provides a more accurate and precise I/O timing data based on the specifics of the design after place-and-route is complete.



The Excel-based I/O Timing spreadsheet is downloadable from [Cyclone IV Devices Literature](#) website.

## Glossary

Table 1-46 lists the glossary for this chapter.

**Table 1-46. Glossary (Part 1 of 5)**

Letter	Term	Definitions
A	—	—
B	—	—
C	—	—
D	—	—
E	—	—
F	$f_{HSCLK}$	High-speed I/O block: High-speed receiver/transmitter input and output clock frequency.
G	GCLK	Input pin directly to Global Clock network.
	GCLK PLL	Input pin to Global Clock network through the PLL.
H	HSIODR	High-speed I/O block: Maximum/minimum LVDS data transfer rate ( $HSIODR = 1/TUI$ ).
I	Input Waveforms for the SSTL Differential I/O Standard	

Table 1-46. Glossary (Part 2 of 5)

Letter	Term	Definitions
J	JTAG Waveform	
K	—	—
L	—	—
M	—	—
N	—	—
O	—	—
P	PLL Block	<p>The following highlights the PLL specification parameters:</p> <p>Key</p> <p>Reconfigurable in User Mode</p>
Q	—	—

Table 1-46. Glossary (Part 3 of 5)

Letter	Term	Definitions
R	$R_L$	Receiver differential input discrete resistor (external to Cyclone IV devices).
	Receiver Input Waveform	<p>Receiver input waveform for LVDS and LVPECL differential standards:</p>  <p>The figure shows two waveforms. The top one is a 'Single-Ended Waveform' with three horizontal lines: 'Positive Channel (p) = <math>V_{IH}</math>', 'Negative Channel (n) = <math>V_{IL}</math>', and 'Ground'. A differential signal is shown between the positive and negative channels, with a peak-to-peak voltage <math>V_{ID}</math> and a common-mode voltage <math>V_{CM}</math> relative to ground. The bottom one is a 'Differential Waveform (Mathematical Function of Positive &amp; Negative Channel)' showing a differential signal centered at 0V with a peak-to-peak voltage <math>V_{ID}</math> and a common-mode level labeled 'p - n'.</p>
	Receiver input skew margin (RSKM)	High-speed I/O block: The total margin left after accounting for the sampling window and TCCS. $RSKM = (TUI - SW - TCCS) / 2$ .
S	Single-ended voltage-referenced I/O Standard	 <p>The diagram shows a trapezoidal signal waveform between <math>V_{OH}</math> and <math>V_{OL}</math> levels. Various voltage thresholds are indicated by horizontal dashed lines: <math>V_{CCIO}</math> (top), <math>V_{OH}</math>, <math>V_{IH(AC)}</math>, <math>V_{IH(DC)}</math>, <math>V_{REF}</math>, <math>V_{IL(DC)}</math>, <math>V_{IL(AC)}</math>, <math>V_{OL}</math>, and <math>V_{SS}</math> (bottom).</p> <p>The JEDEC standard for SSTI and HSTL I/O standards defines both the AC and DC input signal values. The AC values indicate the voltage levels at which the receiver must meet its timing specifications. The DC values indicate the voltage levels at which the final logic state of the receiver is unambiguously defined. After the receiver input crosses the AC value, the receiver changes to the new logic state. The new logic state is then maintained as long as the input stays beyond the DC threshold. This approach is intended to provide predictable receiver timing in the presence of input waveform <i>ringing</i>.</p>
	SW (Sampling Window)	High-speed I/O block: The period of time during which the data must be valid to capture it correctly. The setup and hold times determine the ideal strobe position in the sampling window.

Table 1-46. Glossary (Part 4 of 5)

Letter	Term	Definitions
T	$t_C$	High-speed receiver and transmitter input and output clock period.
	Channel-to-channel-skew (TCCS)	High-speed I/O block: The timing difference between the fastest and slowest output edges, including $t_{CO}$ variation and clock skew. The clock is included in the TCCS measurement.
	$t_{cin}$	Delay from the clock pad to the I/O input register.
	$t_{CO}$	Delay from the clock pad to the I/O output.
	$t_{cout}$	Delay from the clock pad to the I/O output register.
	$t_{DUTY}$	High-speed I/O block: Duty cycle on high-speed transmitter output clock.
	$t_{FALL}$	Signal high-to-low transition time (80–20%).
	$t_H$	Input register hold time.
	Timing Unit Interval (TUI)	High-speed I/O block: The timing budget allowed for skew, propagation delays, and data sampling window. (TUI = 1/(Receiver Input Clock Frequency Multiplication Factor) = $t_C/w$ ).
	$t_{INJITTER}$	Period jitter on the PLL clock input.
	$t_{OUTJITTER\_DEDCLK}$	Period jitter on the dedicated clock output driven by a PLL.
	$t_{OUTJITTER\_IO}$	Period jitter on the general purpose I/O driven by a PLL.
	$t_{pllcin}$	Delay from the PLL inclk pad to the I/O input register.
	$t_{pllcout}$	Delay from the PLL inclk pad to the I/O output register.
	Transmitter Output Waveform	<p>Transmitter output waveforms for the LVDS, mini-LVDS, PPDS and RSDS Differential I/O Standards:</p> <p><b>Single-Ended Waveform</b></p> <p>Positive Channel (p) = <math>V_{OH}</math>  Negative Channel (n) = <math>V_{OL}</math>  Ground</p> <p><b>Differential Waveform (Mathematical Function of Positive &amp; Negative Channel)</b></p> <p>0 V  p - n</p>
$t_{RISE}$	Signal low-to-high transition time (20–80%).	
$t_{SU}$	Input register setup time.	
U	—	—

**Table 1-46. Glossary (Part 5 of 5)**

Letter	Term	Definitions
<b>V</b>	$V_{CM(DC)}$	DC common mode input voltage.
	$V_{DIF(AC)}$	AC differential input voltage: The minimum AC input differential voltage required for switching.
	$V_{DIF(DC)}$	DC differential input voltage: The minimum DC input differential voltage required for switching.
	$V_{ICM}$	Input common mode voltage: The common mode of the differential signal at the receiver.
	$V_{ID}$	Input differential voltage swing: The difference in voltage between the positive and complementary conductors of a differential transmission at the receiver.
	$V_{IH}$	Voltage input high: The minimum positive voltage applied to the input that is accepted by the device as a logic high.
	$V_{IH(AC)}$	High-level AC input voltage.
	$V_{IH(DC)}$	High-level DC input voltage.
	$V_{IL}$	Voltage input low: The maximum positive voltage applied to the input that is accepted by the device as a logic low.
	$V_{IL(AC)}$	Low-level AC input voltage.
	$V_{IL(DC)}$	Low-level DC input voltage.
	$V_{IN}$	DC input voltage.
	$V_{OCM}$	Output common mode voltage: The common mode of the differential signal at the transmitter.
	$V_{OD}$	Output differential voltage swing: The difference in voltage between the positive and complementary conductors of a differential transmission at the transmitter. $V_{OD} = V_{OH} - V_{OL}$ .
	$V_{OH}$	Voltage output high: The maximum positive voltage from an output that the device considers is accepted as the minimum positive high level.
	$V_{OL}$	Voltage output low: The maximum positive voltage from an output that the device considers is accepted as the maximum positive low level.
	$V_{OS}$	Output offset voltage: $V_{OS} = (V_{OH} + V_{OL}) / 2$ .
	$V_{OX(AC)}$	AC differential output cross point voltage: the voltage at which the differential output signals must cross.
	$V_{REF}$	Reference voltage for the SSTL and HSTL I/O standards.
	$V_{REF(AC)}$	AC input reference voltage for the SSTL and HSTL I/O standards. $V_{REF(AC)} = V_{REF(DC)} + \text{noise}$ . The peak-to-peak AC noise on $V_{REF}$ must not exceed 2% of $V_{REF(DC)}$ .
	$V_{REF(DC)}$	DC input reference voltage for the SSTL and HSTL I/O standards.
$V_{SWING(AC)}$	AC differential input voltage: AC input differential voltage required for switching. For the SSTL differential I/O standard, refer to Input Waveforms.	
$V_{SWING(DC)}$	DC differential input voltage: DC input differential voltage required for switching. For the SSTL differential I/O standard, refer to Input Waveforms.	
$V_{TT}$	Termination voltage for the SSTL and HSTL I/O standards.	
$V_X(AC)$	AC differential input cross point voltage: The voltage at which the differential input signals must cross.	
<b>W</b>	—	—
<b>X</b>	—	—
<b>Y</b>	—	—
<b>Z</b>	—	—

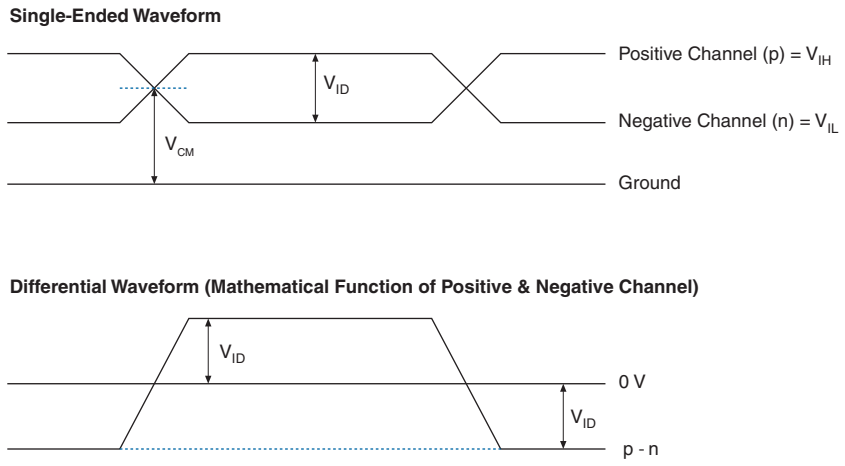
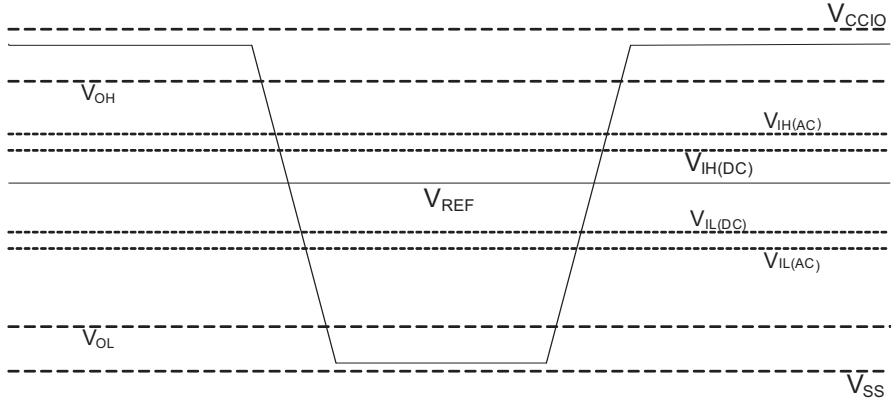
## Document Revision History

Table 1-47 lists the revision history for this chapter.

**Table 1-47. Document Revision History**

Date	Version	Changes
December 2016	2.1	Added note to Table 1-9 and Table 1-10.
March 2016	2.0	Updated note (5) in Table 1-21 to remove support for the N148 package.
October 2014	1.9	Updated maximum value for $V_{CCD\_PLL}$ in Table 1-1. Removed extended temperature note in Table 1-3.
December 2013	1.8	Updated Table 1-21 by adding Note (15).
May 2013	1.7	Updated Table 1-15 by adding Note (4).
October 2012	1.6	<ul style="list-style-type: none"> <li>■ Updated the maximum value for <math>V_I</math>, <math>V_{CCD\_PLL}</math>, <math>V_{CCIO}</math>, <math>V_{CC\_CLKIN}</math>, <math>V_{CCH\_GXB}</math>, and <math>V_{CCA\_GXB}</math> in Table 1-1.</li> <li>■ Updated Table 1-11 and Table 1-22.</li> <li>■ Updated Table 1-21 to include peak-to-peak differential input voltage for the Cyclone IV GX transceiver input reference clock.</li> <li>■ Updated Table 1-29 to include the typical <math>D_{CLK}</math> value.</li> <li>■ Updated the minimum <math>f_{HSCLK}</math> value in Table 1-31, Table 1-32, Table 1-33, Table 1-34, and Table 1-35.</li> </ul>
November 2011	1.5	<ul style="list-style-type: none"> <li>■ Updated “Maximum Allowed Overshoot or Undershoot Voltage”, “Operating Conditions”, and “PLL Specifications” sections.</li> <li>■ Updated Table 1-2, Table 1-3, Table 1-4, Table 1-5, Table 1-8, Table 1-9, Table 1-15, Table 1-18, Table 1-19, and Table 1-21.</li> <li>■ Updated Figure 1-1.</li> </ul>
December 2010	1.4	<ul style="list-style-type: none"> <li>■ Updated for the Quartus II software version 10.1 release.</li> <li>■ Updated Table 1-21 and Table 1-25.</li> <li>■ Minor text edits.</li> </ul>
July 2010	1.3	<p>Updated for the Quartus II software version 10.0 release:</p> <ul style="list-style-type: none"> <li>■ Updated Table 1-3, Table 1-4, Table 1-21, Table 1-25, Table 1-28, Table 1-30, Table 1-40, Table 1-41, Table 1-42, Table 1-43, Table 1-44, and Table 1-45.</li> <li>■ Updated Figure 1-2 and Figure 1-3.</li> <li>■ Removed SW Requirement and TCCS for Cyclone IV Devices tables.</li> <li>■ Minor text edits.</li> </ul>
March 2010	1.2	<p>Updated to include automotive devices:</p> <ul style="list-style-type: none"> <li>■ Updated the “Operating Conditions” and “PLL Specifications” sections.</li> <li>■ Updated Table 1-1, Table 1-8, Table 1-9, Table 1-21, Table 1-26, Table 1-27, Table 1-31, Table 1-32, Table 1-33, Table 1-34, Table 1-35, Table 1-36, Table 1-37, Table 1-38, Table 1-40, Table 1-42, and Table 1-43.</li> <li>■ Added Table 1-5 to include ESD for Cyclone IV devices GPIOs and HSSI I/Os.</li> <li>■ Added Table 1-44 and Table 1-45 to include IOE programmable delay for Cyclone IV E 1.2 V core voltage devices.</li> <li>■ Minor text edits.</li> </ul>

**Table 1-47. Document Revision History**

Date	Version	Changes
February 2010	1.1	<ul style="list-style-type: none"><li data-bbox="565 281 1414 342">■ Updated Table 1-3 through Table 1-44 to include information for Cyclone IV E devices and Cyclone IV GX devices for Quartus II software version 9.1 SP1 release.</li><li data-bbox="565 348 760 375">■ Minor text edits.</li></ul>
November 2009	1.0	Initial release.



## Looking for pricing, stock, or lifecycle information?

Click below to explore more details on WIN SOURCE:

 [View EP4CE115F23C8LN on WIN SOURCE](#)

 [Intel Information](#)

## Optimize Your Supply Chain with WIN SOURCE Solutions

-  Global Sourcing Solution
-  Obsolete Management
-  Cost Control Management
-  Shortage Management
-  Alternative Solution
-  Excess Inventory Management