



**THE DATASHEET OF
AD9484BCPZ-500**



FEATURES

- SNR = 47 dBFS at f_{IN} up to 250 MHz at 500 MSPS**
- ENOB of 7.5 bits at f_{IN} up to 250 MHz at 500 MSPS (−1.0 dBFS)**
- SFDR = 79 dBc at f_{IN} up to 250 MHz at 500 MSPS (−1.0 dBFS)**
- Integrated input buffer**
- Excellent linearity**
 - DNL = ±0.1 LSB typical**
 - INL = ±0.1 LSB typical**
- LVDS at 500 MSPS (ANSI-644 levels)**
- 1 GHz full power analog bandwidth**
- On-chip reference, no external decoupling required**
- Low power dissipation**
 - 670 mW at 500 MSPS—LVDS SDR output**
- Programmable (nominal) input voltage range**
 - 1.18 V p-p to 1.6 V p-p, 1.5 V p-p nominal**
- 1.8 V analog and digital supply operation**
- Selectable output data format (offset binary, twos complement, Gray code)**
- Clock duty cycle stabilizer**
- Integrated data capture clock**

APPLICATIONS

- Wireless and wired broadband communications**
- Cable reverse path**
- Communications test equipment**
- Low cost digital oscilloscopes**
- Satellite subsystems**
- Power amplifier linearization**

GENERAL DESCRIPTION

The AD9484 is an 8-bit, monolithic, sampling analog-to-digital converter (ADC) optimized for high performance, low power, and ease of use. The part operates at up to a 500 MSPS conversion rate and is optimized for outstanding dynamic performance in wideband carrier and broadband systems. All necessary functions, including a sample-and-hold and voltage reference, are included on the chip to provide a complete signal conversion solution. The VREF pin can be used to monitor the internal reference or provide an external voltage reference (external reference mode must be enabled through the SPI port).

The ADC requires a 1.8 V analog voltage supply and a differential clock for full performance operation. The digital outputs are LVDS (ANSI-644) compatible and support twos complement, offset binary format, or Gray code. A data clock output is available for proper output data timing.

Rev. A

Information furnished by Analog Devices is believed to be accurate and reliable. However, no responsibility is assumed by Analog Devices for its use, nor for any infringements of patents or other rights of third parties that may result from its use. Specifications subject to change without notice. No license is granted by implication or otherwise under any patent or patent rights of Analog Devices. Trademarks and registered trademarks are the property of their respective owners.

FUNCTIONAL BLOCK DIAGRAM

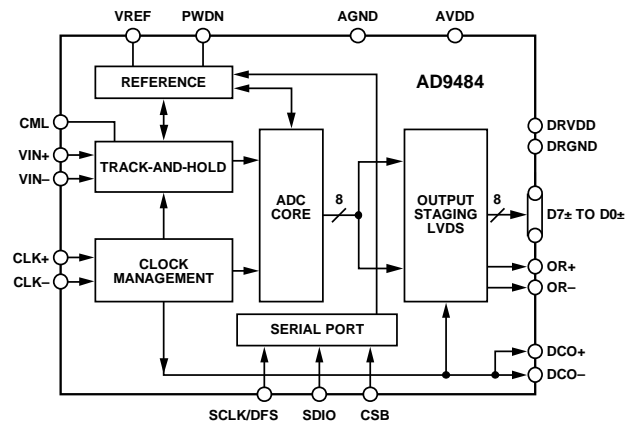

Figure 1.

Fabricated on an advanced BiCMOS process, the AD9484 is available in a 56-lead LFCSP, and is specified over the industrial temperature range (−40°C to +85°C). This product is protected by a U.S. patent.

PRODUCT HIGHLIGHTS

1. **High Performance.**
Maintains 47 dBFS SNR at 500 MSPS with a 250 MHz input.
2. **Ease of Use.**
LVDS output data and output clock signal allow interface to current FPGA technology. The on-chip reference and sample-and-hold provide flexibility in system design. Use of a single 1.8 V supply simplifies system power supply design.
3. **Serial Port Control.**
Standard serial port interface supports various product functions, such as data formatting, power-down, gain adjust, and output test pattern generation.

TABLE OF CONTENTS

Features	1	Theory of Operation	14
Applications.....	1	Analog Input and Voltage Reference	14
Functional Block Diagram	1	Clock Input Considerations.....	15
General Description	1	Power Dissipation and Power-Down Mode	16
Product Highlights	1	Digital Outputs	16
Revision History	2	Timing	17
Specifications.....	3	VREF.....	17
DC Specifications	3	AD9484 Configuration Using the SPI.....	18
AC Specifications.....	4	Hardware Interface.....	18
Digital Specifications	5	Configuration Without the SPI	18
Switching Specifications	6	Memory Map	20
Absolute Maximum Ratings.....	7	Reading the Memory Map Table.....	20
Thermal Resistance	7	Reserved Locations	20
ESD Caution.....	7	Default Values	20
Pin Configuration and Function Descriptions.....	8	Logic Levels.....	20
Typical Performance Characteristics	10	Outline Dimensions	23
Equivalent Circuits	13	Ordering Guide	23

REVISION HISTORY**6/11—Rev. 0 to Rev. A**

Change to General Description Section	1
Change to Aperture Time Parameter in Table 4.....	6
Change to Figure 34	16
Changes to Register 17 and Register 18 in Table 12	20

3/11—Revision 0: Initial Version

SPECIFICATIONS

DC SPECIFICATIONS

AVDD = 1.8 V, DRVDD = 1.8 V, T_{MIN} = -40°C, T_{MAX} = +85°C, f_{IN} = -1.0 dBFS, full scale = 1.5 V, unless otherwise noted.

Table 1.

Parameter ¹	Temp	Min	Typ	Max	Unit
RESOLUTION			8		Bits
ACCURACY					
No Missing Codes	Full		Guaranteed		
Offset Error	25°C		0		mV
Gain Error	Full	-3.0		+3.0	mV
	25°C		1.0		% FS
Differential Nonlinearity (DNL)	Full	-5.0		+7.0	% FS
	25°C		±0.13		LSB
Integral Nonlinearity (INL)	Full	-0.25		+0.25	LSB
	25°C		±0.1		LSB
	Full	-0.15		+0.15	LSB
INTERNAL REFERENCE					
VREF	Full	0.71	0.75	0.78	V
TEMPERATURE DRIFT					
Offset Error	Full		18		μV/°C
Gain Error	Full		0.07		%/°C
ANALOG INPUTS (VIN+, VIN-)					
Differential Input Voltage Range ²	Full	1.18	1.5	1.6	V p-p
Input Common-Mode Voltage	Full		1.7		V
Input Resistance (Differential)	Full		1		kΩ
Input Capacitance (Differential)	Full		1.3		pF
POWER SUPPLY					
AVDD	Full	1.75	1.8	1.9	V
DRVDD	Full	1.75	1.8	1.9	V
Supply Currents					
I _{AVDD} ³	Full		283	300	mA
I _{DRVDD} ³ /SDR Mode ⁴	Full		89	100	mA
Power Dissipation					
SDR Mode ⁴	Full		670	720	mW
Standby Mode	Full		40	50	mW
Power-Down Mode	Full		2.5	7	mW

¹ See the AN-835 Application Note, *Understanding High Speed ADC Testing and Evaluation*, for a complete set of definitions and how these tests were completed.

² The input range is programmable through the SPI, and the range specified reflects the nominal values of each setting. See the Memory Map section.

³ I_{AVDD} and I_{DRVDD} are measured with a -1 dBFS, 10.3 MHz sine input at a rated sample rate.

⁴ Single data rate mode; this is the default mode of the AD9484.

AD9484

AC SPECIFICATIONS

AVDD = 1.8 V, DRVDD = 1.8 V, T_{MIN} = -40°C, T_{MAX} = +85°C, f_{IN} = -1.0 dBFS, full scale = 1.5 V, unless otherwise noted.

Table 2.

Parameter ^{1,2}	Temp	Min	Typ	Max	Unit
SNR					
f _{IN} = 30.3 MHz	25°C		47.0		dBFS
f _{IN} = 70.3 MHz	25°C		47.0		dBFS
f _{IN} = 100.3 MHz	25°C		47.0		dBFS
	Full	46.5			dBFS
f _{IN} = 250.3 MHz	25°C		47.0		dBFS
f _{IN} = 450.3 MHz	25°C		46.9		dBFS
SINAD					
f _{IN} = 30.3 MHz	25°C		47.0		dBFS
f _{IN} = 70.3 MHz	25°C		47.0		dBFS
f _{IN} = 100.3 MHz	25°C		47.0		dBFS
	Full	46.4			dBFS
f _{IN} = 250.3 MHz	25°C		47.0		dBFS
f _{IN} = 450.3 MHz	25°C		46.9		dBFS
EFFECTIVE NUMBER OF BITS (ENOB)					
f _{IN} = 30.3 MHz	25°C		7.5		Bits
f _{IN} = 70.3 MHz	25°C		7.5		Bits
f _{IN} = 100.3 MHz	25°C		7.5		Bits
f _{IN} = 250.3 MHz	25°C		7.5		Bits
f _{IN} = 450.3 MHz	25°C		7.5		Bits
WORST HARMONIC (SECOND or THIRD)					
f _{IN} = 30.3 MHz	25°C		-87		dBc
f _{IN} = 70.3 MHz	25°C		-86		dBc
f _{IN} = 100.3 MHz	25°C		-87		dBc
	Full			-75	dBc
f _{IN} = 250.3 MHz	25°C		83		dBc
f _{IN} = 450.3 MHz	25°C		70		dBc
SFDR					
f _{IN} = 30.3 MHz	25°C		82		dBc
f _{IN} = 70.3 MHz	25°C		81		dBc
f _{IN} = 100.3 MHz	25°C		82		dBc
	Full	75			dBc
f _{IN} = 250.3 MHz	25°C		79		dBc
f _{IN} = 450.3 MHz	25°C		70		dBc
WORST OTHER HARMONIC (SFDR EXCLUDING SECOND and THIRD)					
f _{IN} = 30.3 MHz	25°C		-82		dBc
f _{IN} = 70.3 MHz	25°C		-81		dBc
f _{IN} = 100.3 MHz	25°C		-82		dBc
	Full			-75	dBc
f _{IN} = 250.3 MHz	25°C		79		dBc
f _{IN} = 450.3 MHz	25°C		77		dBc
TWO-TONE IMD					
f _{IN1} = 119.5 MHz, f _{IN2} = 122.5 MHz	25°C		-77		dBc
ANALOG INPUT BANDWIDTH					
Full Power	25°C		1		GHz

¹ All ac specifications tested by driving CLK+ and CLK- differentially.

² See the AN-835 Application Note, *Understanding High Speed ADC Testing and Evaluation*, for a complete set of definitions and how these tests were completed.

DIGITAL SPECIFICATIONS

AVDD = 1.8 V, DRVDD = 1.8 V, T_{MIN} = -40°C, T_{MAX} = +85°C, f_{IN} = -1.0 dBFS, full scale = 1.5 V, unless otherwise noted.

Table 3.

Parameter ¹	Temp	Min	Typ	Max	Unit
CLOCK INPUTS					
Logic Compliance	Full	CMOS/LVDS/LVPECL			
Internal Common-Mode Bias	Full	0.9			V
Differential Input Voltage					
High Level Input (V _{IH})	Full	0.2		1.8	V p-p
Low Level Input (V _{IL})	Full	-1.8		-0.2	V p-p
High Level Input Current (I _{IH})	Full	-10		+10	μA
Low Level Input Current (I _{IL})	Full	-10		+10	μA
Input Resistance (Differential)	Full	8	10	12	kΩ
Input Capacitance	Full		4		pF
LOGIC INPUTS					
Logic 1 Voltage	Full	0.8 × DRVDD			V
Logic 0 Voltage	Full			0.2 × DRVDD	V
Logic 1 Input Current (SDIO, CSB)	Full		0		μA
Logic 0 Input Current (SDIO, CSB)	Full		-60		μA
Logic 1 Input Current (SCLK, PDWN)	Full		50		μA
Logic 0 Input Current (SCLK, PDWN)	Full		0		μA
Input Capacitance	Full		4		pF
LOGIC OUTPUTS²					
V _{OD} Differential Output Voltage	Full	247		454	mV
V _{OS} Output Offset Voltage	Full	1.125		1.375	V
Output Coding					

¹ See the AN-835 Application Note, *Understanding High Speed ADC Testing and Evaluation*, for a complete set of definitions and how these tests were completed.

² LVDS R_{TERMINATION} = 100 Ω.

SWITCHING SPECIFICATIONS

AVDD = 1.8 V, DRVDD = 1.8 V, T_{MIN} = -40°C, T_{MAX} = +85°C, f_{IN} = -1.0 dBFS, full scale = 1.5 V, unless otherwise noted.

Table 4.

Parameter	Temp	Min	Typ	Max	Unit
Maximum Conversion Rate	Full	500			MSPS
Minimum Conversion Rate	Full			50	MSPS
CLK+ Pulse Width High (t _{CH}) ¹	Full	0.9		11	ns
CLK+ Pulse Width Low (t _{CL}) ¹	Full	0.9		11	ns
Output (LVDS—SDR) ¹					
Data Propagation Delay (t _{PD})	Full		0.85		ns
Rise Time (t _r) (20% to 80%)	25°C		0.15		ns
Fall Time (t _f) (20% to 80%)	25°C		0.15		ns
DCO Propagation Delay (t _{CPD})	Full		0.6		ns
Data to DCO Skew (t _{SKEW})	Full	-0.07		+0.07	ns
Latency	Full		15		Clock cycles
Aperture Time (t _A)	25°C		0.85		ns
Aperture Uncertainty (Jitter, t _j)	25°C		80		fs rms

¹ See Figure 2.

Timing Diagram

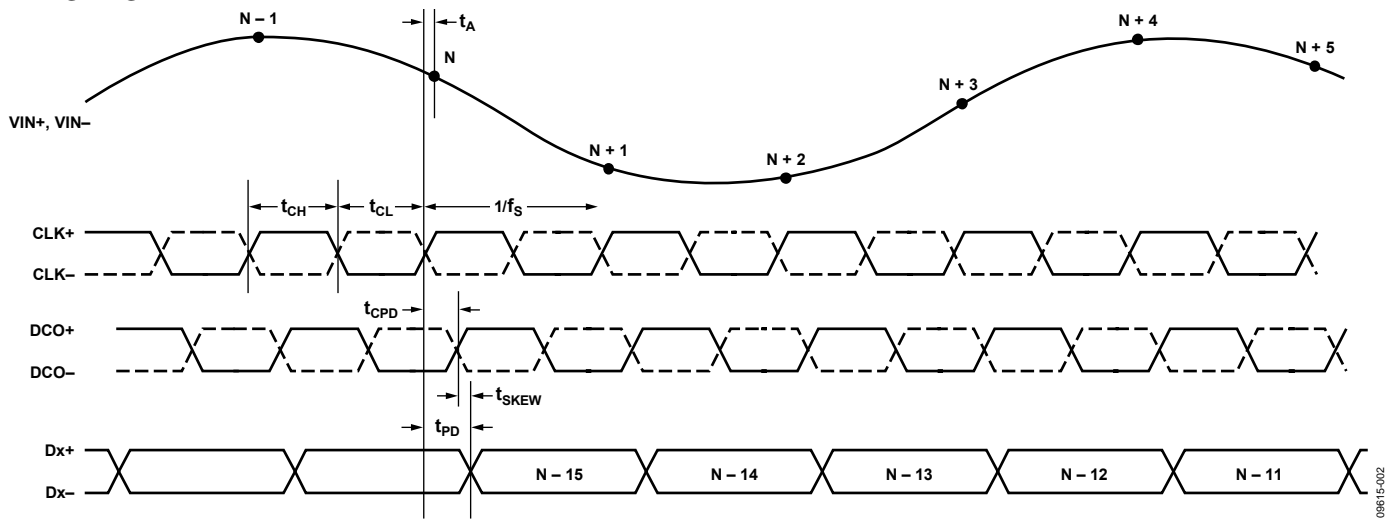

Figure 2. Timing Diagram

ABSOLUTE MAXIMUM RATINGS

Table 5.

Parameter	Rating
Electrical	
AVDD to AGND	−0.3 V to +2.0 V
DRVDD to DRGND	−0.3 V to +2.0 V
AGND to DRGND	−0.3 V to +0.3 V
AVDD to DRVDD	−2.0 V to +2.0 V
D0+/D0− through D7+/D7− to DRGND	−0.3 V to DRVDD + 0.2 V
DCO+, DCO− to DRGND	−0.3 V to DRVDD + 0.2 V
OR+, OR− to DRGND	−0.3 V to DRVDD + 0.2 V
CLK+ to AGND	−0.3 V to AVDD + 0.2 V
CLK− to AGND	−0.3 V to AVDD + 0.2 V
VIN+ to AGND	−0.3 V to AVDD + 0.2 V
VIN− to AGND	−0.3 V to AVDD + 0.2 V
SDIO/DCS to DRGND	−0.3 V to DRVDD + 0.2 V
PDWN to AGND	−0.3 V to DRVDD + 0.2 V
CSB to AGND	−0.3 V to DRVDD + 0.2 V
SCLK/DFS to AGND	−0.3 V to DRVDD + 0.2 V
CML to AGND	−0.3 V to AVDD + 0.2 V
VREF to AGND	−0.3 V to AVDD + 0.2 V
Environmental	
Storage Temperature Range	−65°C to +125°C
Operating Temperature Range	−40°C to +85°C
Lead Temperature (Soldering, 10 sec)	300°C
Junction Temperature	150°C

Stresses above those listed under Absolute Maximum Ratings may cause permanent damage to the device. This is a stress rating only; functional operation of the device at these or any other conditions above those indicated in the operational section of this specification is not implied. Exposure to absolute maximum rating conditions for extended periods may affect device reliability.

THERMAL RESISTANCE

The exposed paddle must be soldered to the ground plane for the LFCSP package. Soldering the exposed paddle to the PCB increases the reliability of the solder joints, maximizing the thermal capability of the package.

Table 6.

Package Type	θ_{JA}	θ_{JC}	Unit
56-Lead LFCSP_VQ (CP-56-5)	23.7	1.7	°C/W

Typical θ_{JA} and θ_{JC} are specified for a 4-layer board in still air. Airflow increases heat dissipation, effectively reducing θ_{JA} . In addition, metal in direct contact with the package leads from metal traces, through holes, ground, and power planes reduces the θ_{JA} .

ESD CAUTION



ESD (electrostatic discharge) sensitive device. Charged devices and circuit boards can discharge without detection. Although this product features patented or proprietary protection circuitry, damage may occur on devices subjected to high energy ESD. Therefore, proper ESD precautions should be taken to avoid performance degradation or loss of functionality.

PIN CONFIGURATION AND FUNCTION DESCRIPTIONS

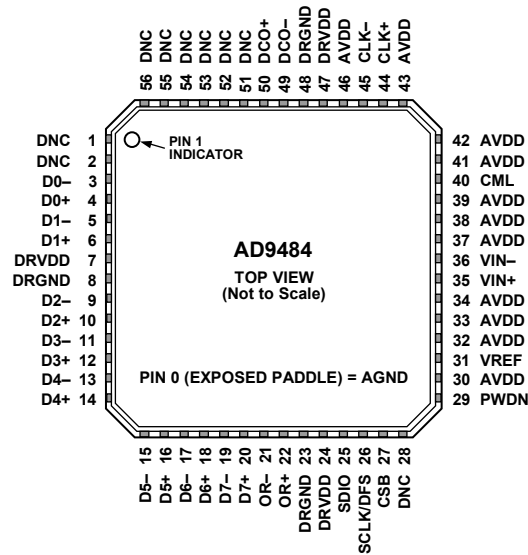

- NOTES**
1. DNC = DO NOT CONNECT. DO NOT CONNECT TO THIS PIN.
 2. AGND AND DRGND SHOULD BE TIED TO A COMMON QUIET GROUND PLANE.
 3. THE EXPOSED PADDLE MUST BE SOLDERED TO A GROUND PLANE.

098155-0/03

Figure 3. Pin Configuration

Table 7. Pin Function Descriptions

Pin No.	Mnemonic	Description
0	AGND ¹	Analog Ground. The exposed paddle must be soldered to a ground plane.
30, 32 to 34, 37 to 39, 41 to 43, 46	AVDD	1.8 V Analog Supply.
7, 24, 47	DRVDD	1.8 V Digital Output Supply.
8, 23, 48	DRGND ¹	Digital Output Ground.
35	VIN+	Analog Input—True.
36	VIN–	Analog Input—Complement.
40	CML	Common-Mode Output. Enabled through the SPI, this pin provides a reference for the optimized internal bias voltage for VIN+/VIN–.
44	CLK+	Clock Input—True.
45	CLK–	Clock Input—Complement.
31	VREF	Voltage Reference Internal/Input/Output. Nominally 0.75 V.
1, 2, 28, 51 to 56	DNC	Do Not Connect. Do not connect to this pin. This pin should be left floating.
25	SDIO	Serial Port Interface (SPI) Data Input/Output.
26	SCLK/DFS	Serial Port Interface Clock (Serial Port Mode)/Data Format Select (External Pin Mode).
27	CSB	Serial Port Chip Select (Active Low).
29	PWDN	Chip Power-Down.
49	DCO–	Data Clock Output—Complement.
50	DCO+	Data Clock Output—True.
3	D0–	D0 Complement Output (LSB).
4	D0+	D0 True Output (LSB).
5	D1–	D1 Complement Output.
6	D1+	D1 True Output.
9	D2–	D2 Complement Output.
10	D2+	D2 True Output.
11	D3–	D3 Complement Output.
12	D3+	D3 True Output.
13	D4–	D4 Complement Output.

Pin No.	Mnemonic	Description
14	D4+	D4 True Output.
15	D5-	D5 Complement Output.
16	D5+	D5 True Output.
17	D6-	D6 Complement Output.
18	D6+	D6 True Output.
19	D7-	D7 Complement Output (MSB).
20	D7+	D7 True Output (MSB).
21	OR-	Overrange Complement Output.
22	OR+	Overrange True Output.

¹ Tie AGND and DRGND to a common quiet ground plane.

TYPICAL PERFORMANCE CHARACTERISTICS

AVDD = 1.8 V, DRVDD = 1.8 V, rated sample rate, $T_A = 25^\circ\text{C}$, 1.5 V p-p differential input, AIN = -1 dBFS, unless otherwise noted.

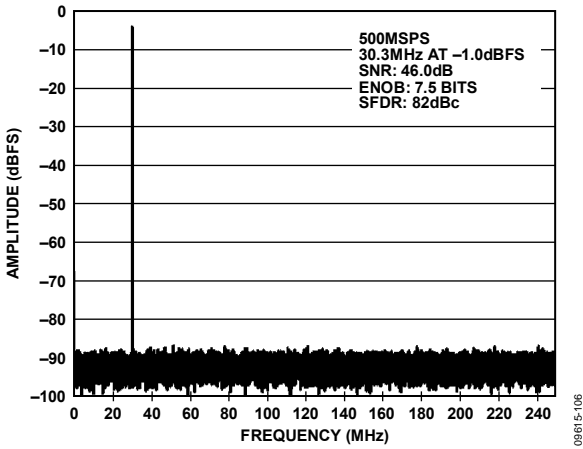

Figure 4. 64k Point Single-Tone FFT; 500 MSPS, 30.3 MHz

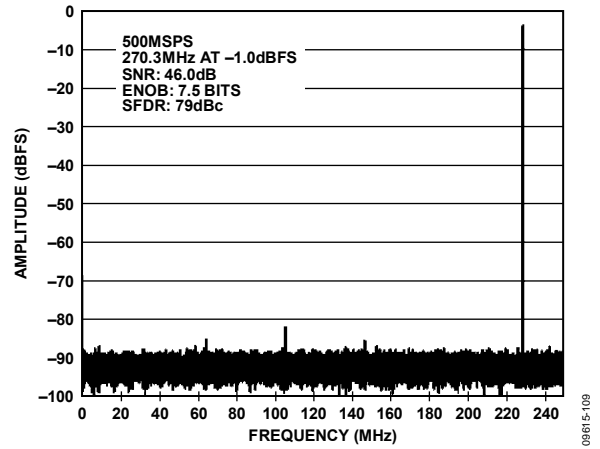

Figure 7. 64k Point Single-Tone FFT; 500 MSPS, 270.3 MHz

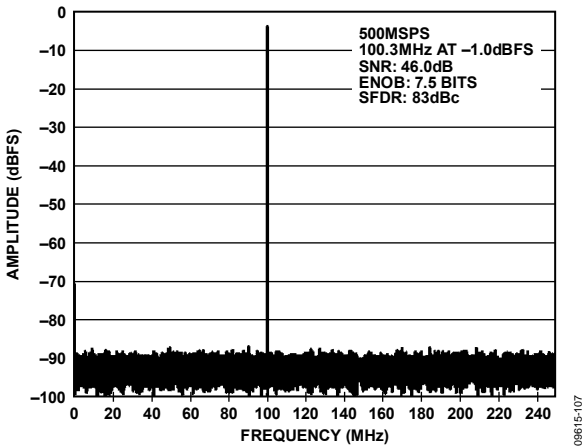

Figure 5. 64k Point Single-Tone FFT; 500 MSPS, 100.3 MHz

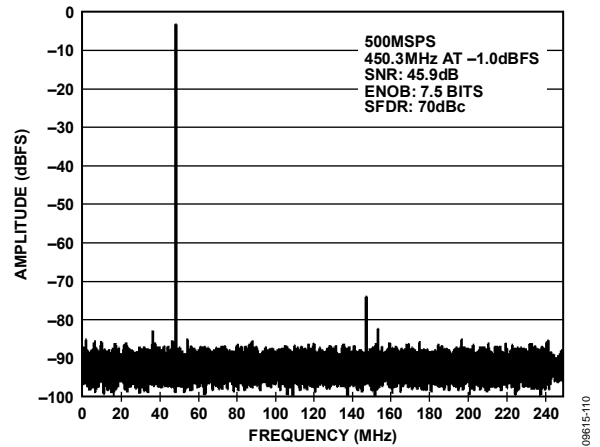

Figure 8. 64k Point Single-Tone FFT; 500 MSPS, 450.3 MHz

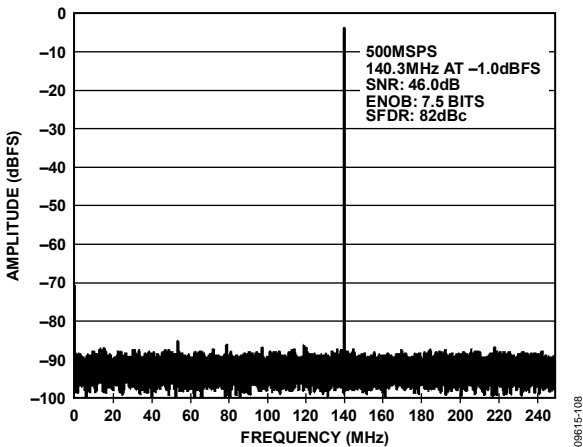

Figure 6. 64k Point Single-Tone FFT; 500 MSPS, 140.3 MHz

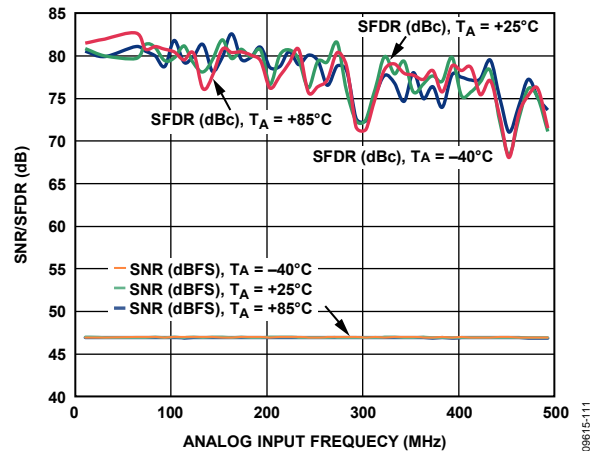

Figure 9. Single-Tone SNR/SFDR vs. Input Frequency (f_{IN}) and Temperature; 500 MSPS

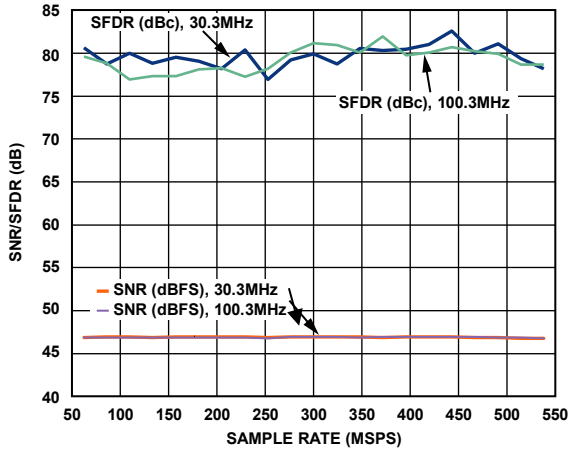

Figure 10. SNR/SFDR vs. Sample Rate; 30.3 MHz, 100.3 MHz

09615-112

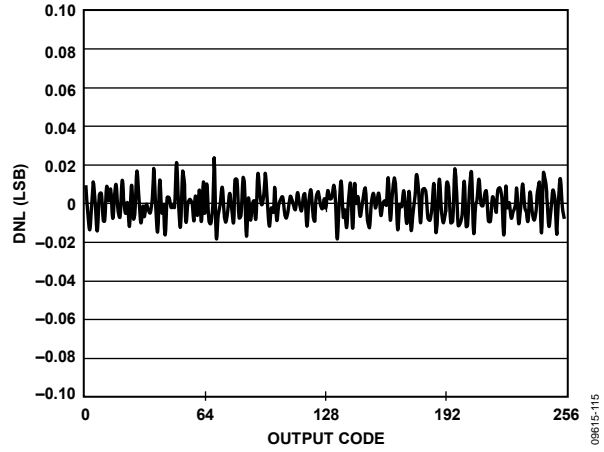

Figure 13. DNL, 500 MSPS

09615-115

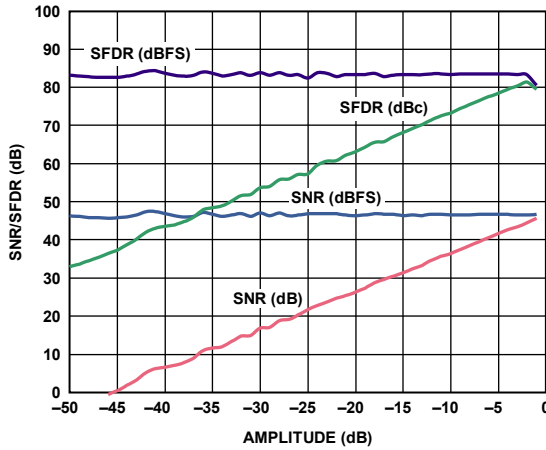

Figure 11. SNR/SFDR vs. Input Amplitude; 500 MSPS, 140.3 MHz

09615-211

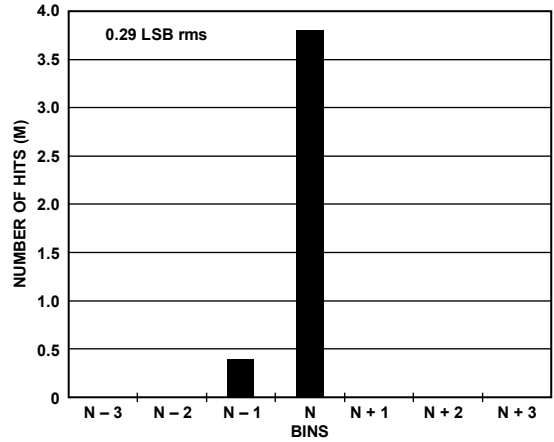

Figure 14. Grounded Input Histogram, 500 MSPS

09615-116

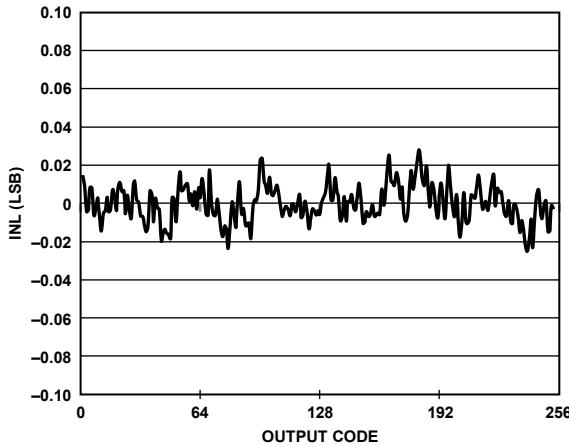

Figure 12. INL, 500 MSPS

09615-114

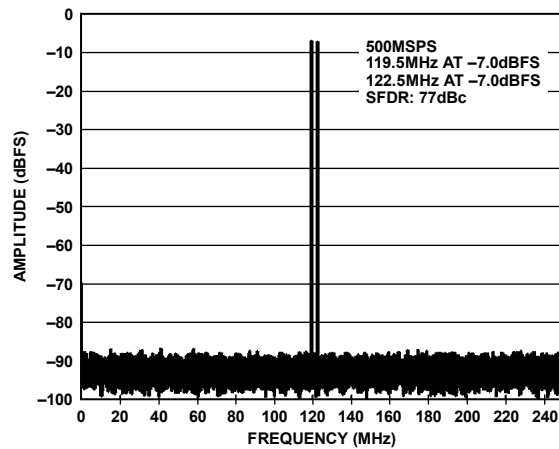

Figure 15. 64k Point, Two-Tone FFT; 500 MSPS, 119.2 MHz, 122.5 MHz

09615-215

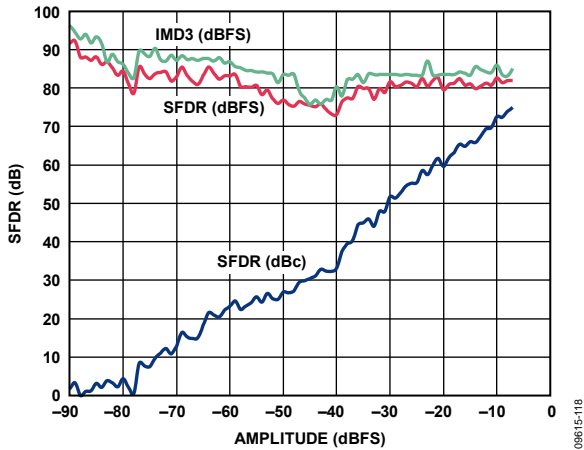

Figure 16. Two-Tone SFDR vs. Input Amplitude; 500 MSPS, 119.5 MHz, 122.5 MHz

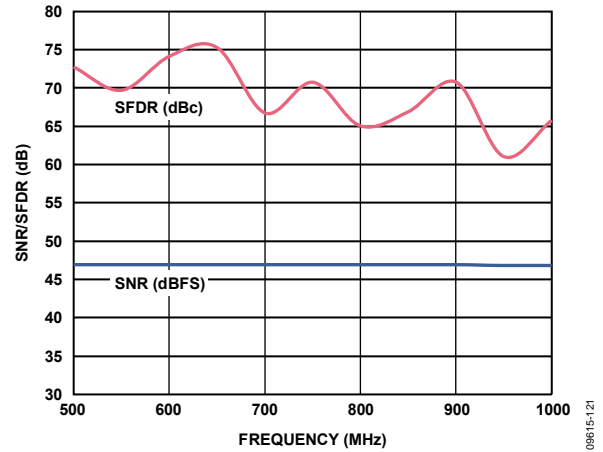

Figure 19. SNR/SFDR at 500 MSPS; AIN Sweep at -1.0 dBFS

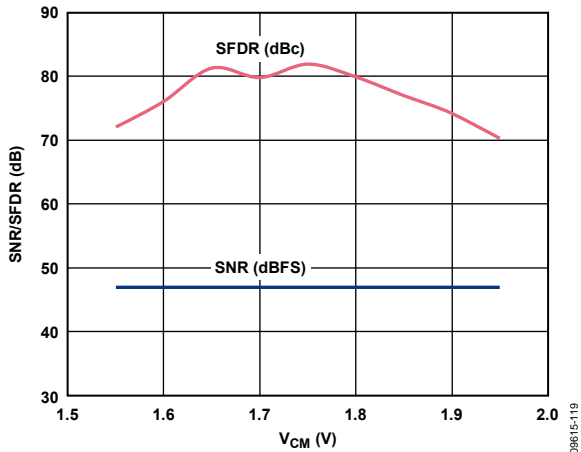

Figure 17. SNR/SFDR vs. Common-Mode Voltage; 500 MSPS, AIN = 140.3 MHz

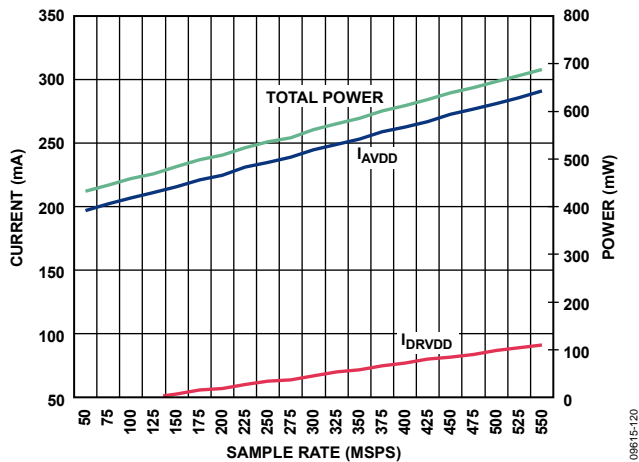

Figure 18. Current and Power vs. Sample Rate, AIN = 30.3 MHz

09815-118

09815-121

09815-119

09815-120

EQUIVALENT CIRCUITS

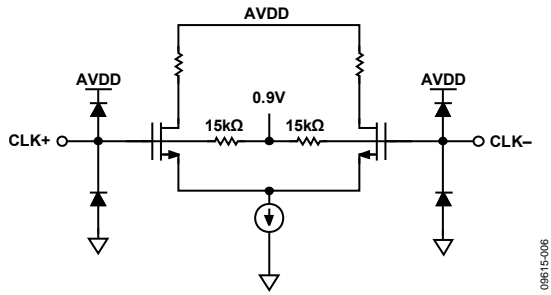

Figure 20. Clock Inputs

09615-006

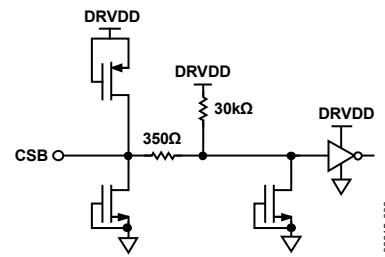

Figure 24. Equivalent CSB Input Circuit

09615-009

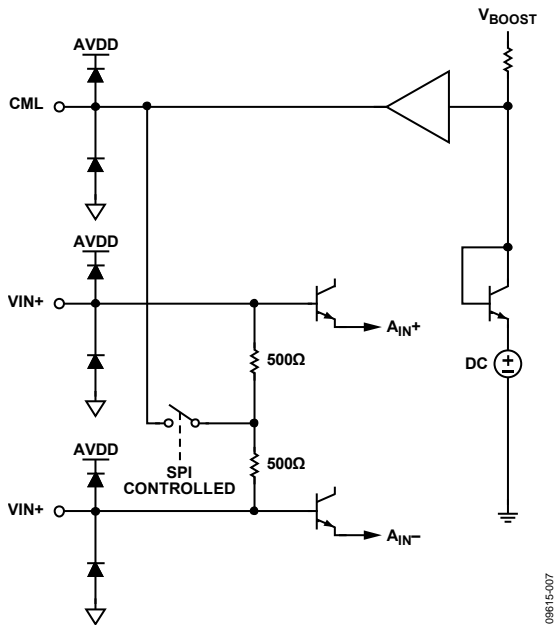

Figure 21. Analog Input DC Equivalent Circuit ($V_{CML} \approx 1.7V$)

09615-007

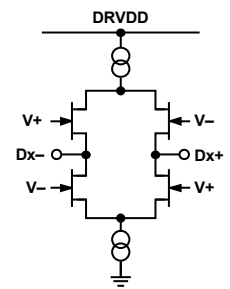

Figure 25. LVDS Outputs ($Dx+$, $Dx-$, $OR+$, $OR-$, $DCO+$, $DCO-$)

09615-010

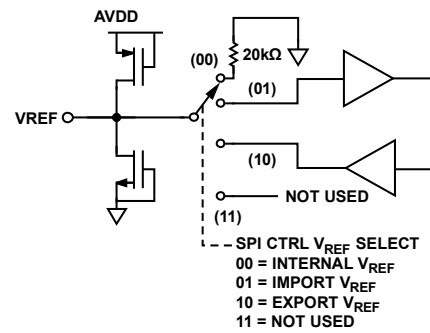

Figure 26. Equivalent VREF Input/Output Circuit

09615-011

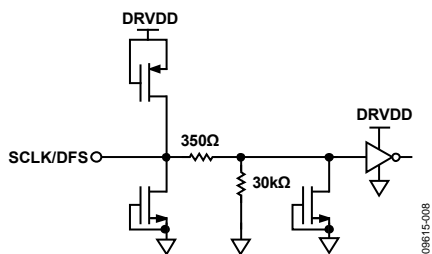

Figure 22. Equivalent SCLK/DFS, PDWN Input Circuit

09615-008

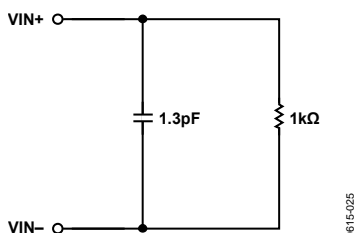

Figure 23. Analog Input AC Equivalent Circuit

09615-025

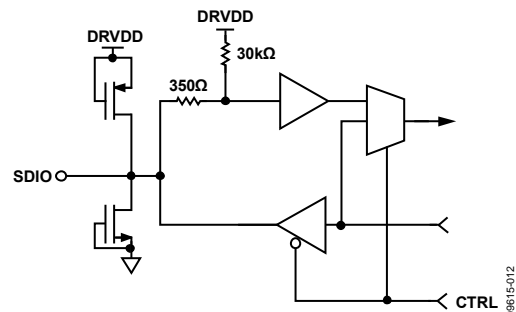

Figure 27. Equivalent SDIO Input Circuit

09615-012

THEORY OF OPERATION

The AD9484 architecture consists of a front-end sample-and-hold amplifier (SHA) followed by a pipelined switched capacitor ADC. The quantized outputs from each stage are combined into a final 8-bit result in the digital correction logic. The pipelined architecture permits the first stage to operate on a new input sample, whereas the remaining stages operate on preceding samples. Sampling occurs on the rising edge of the clock.

Each stage of the pipeline, excluding the last, consists of a low resolution flash ADC connected to a switched capacitor DAC and interstage residue amplifier (MDAC). The residue amplifier magnifies the difference between the reconstructed DAC output and the flash input for the next stage in the pipeline. One bit of redundancy is used in each stage to facilitate digital correction of flash errors. The last stage simply consists of a flash ADC.

The input stage contains a differential SHA that can be ac- or dc-coupled in differential or single-ended mode. The output staging block aligns the data, carries out the error correction, and passes the data to the output buffers. The output buffers are powered from a separate supply, allowing adjustment of the output voltage swing. During power-down, the output buffers enter a high impedance state.

ANALOG INPUT AND VOLTAGE REFERENCE

The analog input to the AD9484 is a differential buffer. For best dynamic performance, match the source impedances driving VIN+ and VIN- such that common-mode settling errors are symmetrical. The analog input is optimized to provide superior wideband performance and requires that the analog inputs be driven differentially. SNR and SINAD performance degrades significantly if the analog input is driven with a single-ended signal.

A wideband transformer, such as Mini-Circuits® ADT1-1WT, can provide the differential analog inputs for applications that require a single-ended-to-differential conversion. Both analog inputs are self-biased by an on-chip reference to a nominal 1.7 V.

An internal differential voltage reference creates positive and negative reference voltages that define the 1.5 V p-p fixed span of the ADC core. This internal voltage reference can be adjusted by means of SPI control. See the AD9484 Configuration Using the SPI section for more details.

Differential Input Configurations

Optimum performance is achieved while driving the AD9484 in a differential input configuration. For baseband applications, the AD8138 differential driver provides excellent performance and a flexible interface to the ADC. The output common-mode voltage of the AD8138 is easily set to $AVDD/2 + 0.5\text{ V}$, and the driver can be configured in a Sallen-Key filter topology to provide band limiting of the input signal.

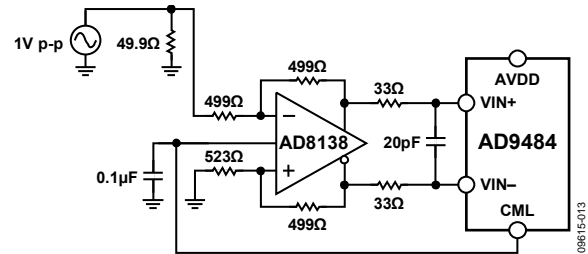

Figure 28. Differential Input Configuration Using the AD8138

At input frequencies in the second Nyquist zone and above, the performance of most amplifiers may not be adequate to achieve the true performance of the AD9484. This is especially true in IF undersampling applications where frequencies in the 70 MHz to 100 MHz range are being sampled. For these applications, differential transformer coupling is the recommended input configuration. The signal characteristics must be considered when selecting a transformer. Most RF transformers saturate at frequencies below a few megahertz (MHz), and excessive signal power can cause core saturation, which leads to distortion.

In any configuration, the value of the shunt capacitor, C (see Figure 30), is dependent on the input frequency and may need to be reduced or removed.

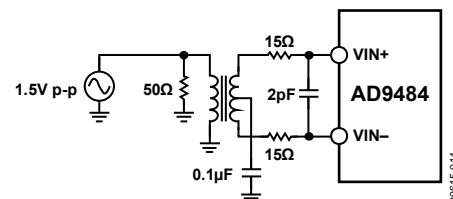

Figure 29. Differential Transformer—Coupled Configuration

As an alternative to using a transformer-coupled input at frequencies in the second Nyquist zone, the AD8352 differential driver can be used (see Figure 30).

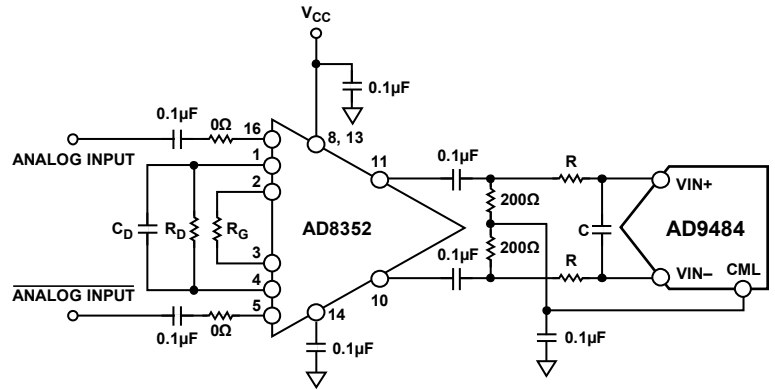
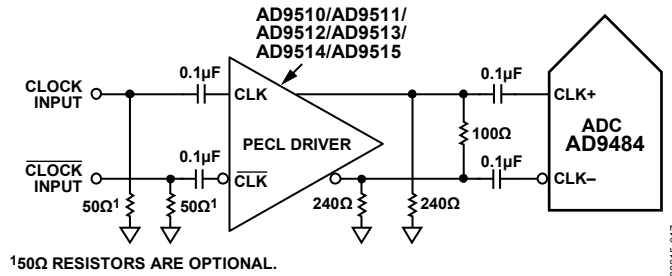
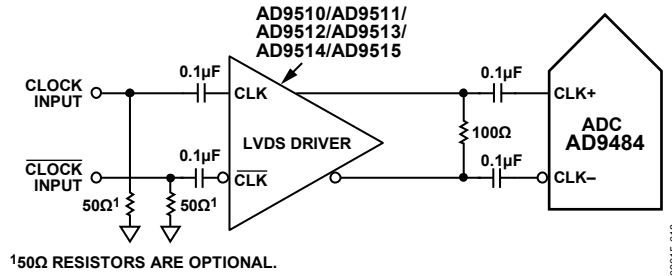

Figure 30. Differential Input Configuration Using the AD8352



150Ω RESISTORS ARE OPTIONAL.

Figure 31. Differential PECL Sample Clock



150Ω RESISTORS ARE OPTIONAL.

Figure 32. Differential LVDS Sample Clock

CLOCK INPUT CONSIDERATIONS

For optimum performance, drive the AD9484 sample clock inputs (CLK+ and CLK-) with a differential signal. This signal is typically ac-coupled into the CLK+ and CLK- pins via a transformer or capacitors. These pins are biased at ~0.9 V internally and require no additional bias. If the clock signal is dc-coupled, then the common-mode voltage should remain within a range of 0.9 V.

Figure 33 shows one preferred method for clocking the AD9484. The low jitter clock source is converted from single-ended to differential using an RF transformer. The back-to-back Schottky diodes across the secondary transformer limit clock excursions into the AD9484 to approximately 0.8 V p-p differential. This helps prevent the large voltage swings of the clock from feeding through to other portions of the AD9484 and preserves the fast rise and fall times of the signal, which are critical to low jitter performance.

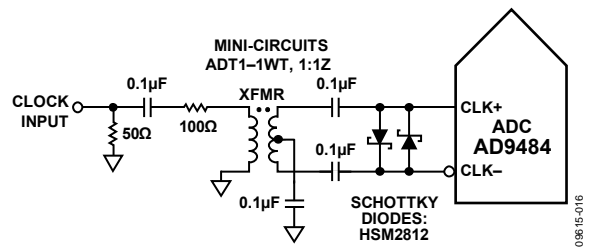
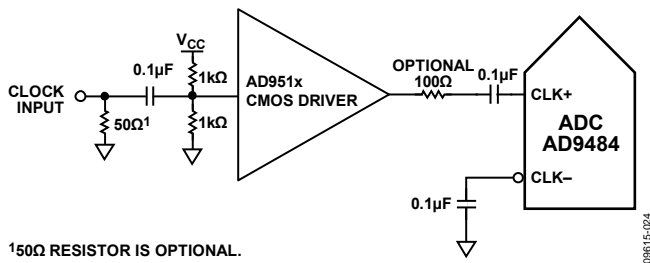

Figure 33. Transformer-Coupled Differential Clock

If a low jitter clock is available, another option is to ac couple a differential PECL signal to the sample clock input pins, as shown in Figure 31. The AD9510/AD9511/AD9512/AD9513/AD9514/AD9515 family of clock drivers offers excellent jitter performance.

In some applications, it may be acceptable to drive the sample clock inputs with a single-ended 1.8 V CMOS signal. In such applications, drive the CLK+ pin directly from a CMOS gate, and bypass the CLK- pin to ground with a 0.1 µF capacitor in parallel with a 39 kΩ resistor (see Figure 34).

AD9484



150Ω RESISTOR IS OPTIONAL.

Figure 34. Single-Ended 1.8 V CMOS Input Clock (Up to 200 MHz)

Clock Duty Cycle Considerations

Typical high speed ADCs use both clock edges to generate a variety of internal timing signals. As a result, these ADCs may be sensitive to clock duty cycle. A 5% tolerance is commonly required on the clock duty cycle to maintain dynamic performance characteristics. The AD9484 contains a duty cycle stabilizer (DCS) that retimes the nonsampling edge, providing an internal clock signal with a nominal 50% duty cycle. This allows a wide range of clock input duty cycles without affecting the performance of the AD9484. When the DCS is on, noise and distortion performance are nearly flat for a wide range of duty cycles.

The duty cycle stabilizer uses a delay-locked loop (DLL) to create the nonsampling edge. As a result, any changes to the sampling frequency require approximately 15 clock cycles to allow the DLL to acquire and lock to the new rate.

Clock Jitter Considerations

High speed, high resolution ADCs are sensitive to the quality of the clock input. The degradation in SNR at a given input frequency (f_A) due only to aperture jitter (t_j) can be calculated by

$$\text{SNR Degradation} = 20 \times \log_{10}(1/2 \times \pi \times f_A \times t_j)$$

In this equation, the rms aperture jitter represents the root mean square of all jitter sources, including the clock input, analog input signal, and ADC aperture jitter specifications. IF undersampling applications are particularly sensitive to jitter (see Figure 35).

Treat the clock input as an analog signal in cases where aperture jitter may affect the dynamic range of the AD9484. Separate the power supplies for clock drivers from the ADC output driver supplies to avoid modulating the clock signal with digital noise. Low jitter, crystal-controlled oscillators make the best clock sources. If the clock is generated from another type of source (by gating, dividing, or other methods), it should be retimed by the original clock at the last step.

Refer to the [AN-501](#) Application Note and the [AN-756](#) Application Note for more in-depth information about jitter performance as it relates to ADCs (visit www.analog.com).

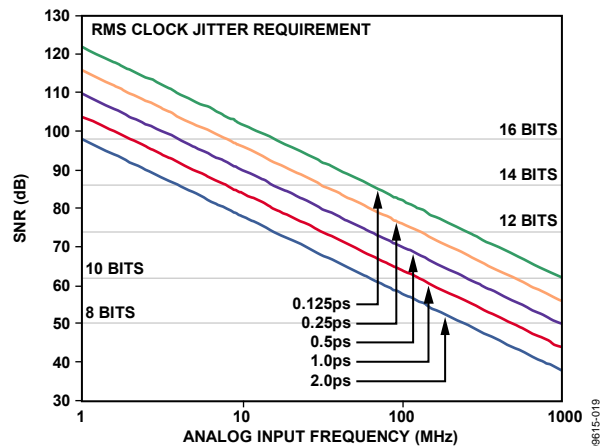

Figure 35. Ideal SNR vs. Input Frequency and Jitter

POWER DISSIPATION AND POWER-DOWN MODE

As shown in Figure 18, the power dissipated by the AD9484 is proportional to its sample rate. The digital power dissipation does not vary much because it is determined primarily by the DRVDD supply and bias current of the LVDS output drivers.

By asserting PDWN (Pin 29) high, the AD9484 is placed in standby mode or full power-down mode, as determined by the contents of Serial Port Register 08. Reasserting the PDWN pin low returns the AD9484 to its normal operational mode.

An additional standby mode is supported by means of varying the clock input. When the clock rate falls below 50 MHz, the AD9484 assumes a standby state. In this case, the biasing network and internal reference remain on, but digital circuitry is powered down. Upon reactivating the clock, the AD9484 resumes normal operation after allowing for the pipeline latency.

DIGITAL OUTPUTS

Digital Outputs and Timing

The AD9484 differential outputs conform to the ANSI-644 LVDS standard on default power-up. This can be changed to a low power, reduced signal option similar to the IEEE 1596.3 standard using the SPI. This LVDS standard can further reduce the overall power dissipation of the device, which reduces the power by ~39 mW. See the Memory Map section for more information. The LVDS driver current is derived on chip and sets the output current at each output equal to a nominal 3.5 mA. A 100 Ω differential termination resistor placed at the LVDS receiver inputs results in a nominal 350 mV swing at the receiver.

The AD9484 LVDS outputs facilitate interfacing with LVDS receivers in custom ASICs and FPGAs that have LVDS capability for superior switching performance in noisy environments. Single point-to-point net topologies are recommended with a 100 Ω termination resistor placed as close to the receiver as possible. No far-end receiver termination or poor differential trace routing may result in timing errors. It is recommended that the trace length be no longer than 24 inches and that the

differential output traces be kept close together and at equal lengths.

An example of the LVDS output using the ANSI standard (default) data eye and a time interval error (TIE) jitter histogram with trace lengths less than 24 inches on regular FR-4 material is shown in Figure 36. Figure 37 shows an example of when the trace lengths exceed 24 inches on regular FR-4 material. Notice that the TIE jitter histogram reflects the decrease of the data eye opening as the edge deviates from the ideal position. It is up to the user to determine if the waveforms meet the timing budget of the design when the trace lengths exceed 24 inches.

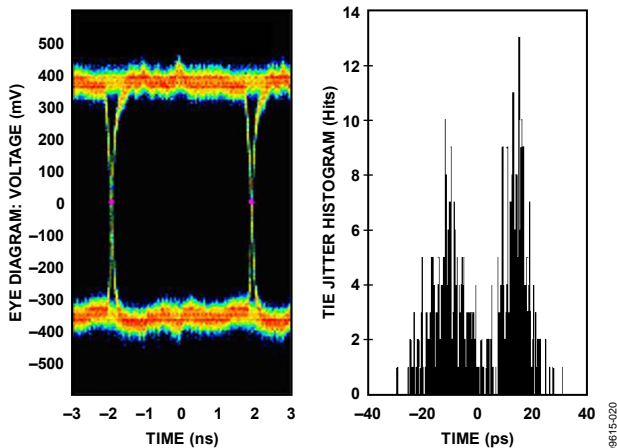

Figure 36. Data Eye for LVDS Outputs in ANSI Mode with Trace Lengths Less Than 24 Inches on Standard FR-4

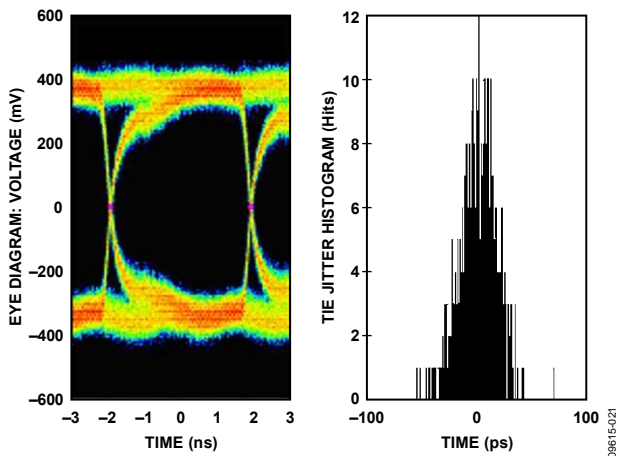

Figure 37. Data Eye for LVDS Outputs in ANSI Mode with Trace Lengths Greater Than 24 Inches on Standard FR-4

The format of the output data is offset binary by default. An example of the output coding format can be found in Table 11. If it is desired to change the output data format to twos complement, see the AD9484 Configuration Using the SPI section.

An output clock signal is provided to assist in capturing data from the AD9484. The DCO is used to clock the output data and is equal to the sampling clock (CLK) rate. In single data rate mode (SDR), data is clocked out of the AD9484 and must be captured on the rising edge of the DCO. See the timing diagram shown in Figure 2 for more information.

Output Data Rate and Pinout Configuration

The output data of the AD9484 can be configured to drive 12 pairs of LVDS outputs at the same rate as the input clock signal (SDR mode).

Out-of-Range (OR)

An out-of-range condition exists when the analog input voltage is beyond the input range of the ADC. OR+ and OR- (OR±) are digital outputs that are updated along with the data output corresponding to the particular sampled input voltage. Thus, OR± has the same pipeline latency as the digital data. OR± is low when the analog input voltage is within the analog input range and high when the analog input voltage exceeds the input range, as shown in Figure 38. OR± remains high until the analog input returns to within the input range and another conversion is completed. By logically AND'ing OR± with the MSB and its complement, overrange high or underrange low conditions can be detected.

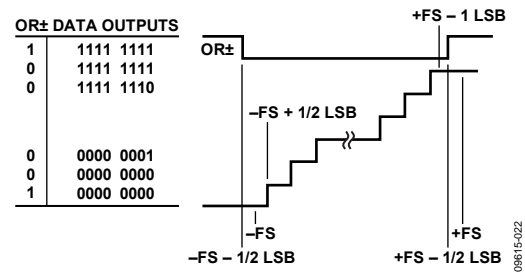

Figure 38. OR± Relation to Input Voltage and Output Data

TIMING

The AD9484 provides latched data outputs with a pipeline delay of 15 clock cycles. Data outputs are available one propagation delay (t_{PD}) after the rising edge of the clock signal.

Minimize the length of the output data lines and loads placed on them to reduce transients within the AD9484. These transients can degrade the dynamic performance of the converter. The AD9484 also provides a data clock output (DCO) intended for capturing the data in an external register. The data outputs are valid on the rising edge of DCO.

The lowest conversion rate of the AD9484 is 50 MSPS. At clock rates below 1 MSPS, the AD9484 assumes the standby mode.

VREF

The AD9484 VREF pin (Pin 31) allows the user to monitor the on-board voltage reference, or provide an external reference (requires configuration through the SPI). The three optional settings are internal V_{REF} (pin is connected to 20 kΩ to ground), export V_{REF} , and import V_{REF} . Do not attach a bypass capacitor to this pin. VREF is internally compensated and additional loading may impact performance.

AD9484 CONFIGURATION USING THE SPI

The AD9484 SPI allows the user to configure the converter for specific functions or operations through a structured register space inside the ADC. This gives the user added flexibility to customize device operation depending on the application. Addresses are accessed (programmed or readback) serially in 1-byte words. Each byte can be further divided into fields, which are documented in the Memory Map section.

There are three pins that define the serial port interface (SPI) to this particular ADC. They are the SCLK/DFS, SDIO and CSB pins. The SCLK/DFS (serial clock) is used to synchronize the read and write data presented the ADC. The SDIO (serial data input/output) is a dual-purpose pin that allows data to be sent to and read from the internal ADC memory map registers. The CSB is an active low control that enables or disables the read and write cycles (see Table 8).

Table 8. Serial Port Pins

Mnemonic	Function
SCLK	SCLK (serial clock) is the serial shift clock in. SCLK is used to synchronize serial interface reads and writes.
SDIO	SDIO (serial data input/output) is a dual-purpose pin. The typical role for this pin is an input and output depending on the instruction being sent and the relative position in the timing frame.
CSB	CSB (chip select) is an active low control that gates the read and write cycles.

The falling edge of the CSB, in conjunction with the rising edge of the SCLK, determines the start of the framing. An example of the serial timing and its definitions can be found in Figure 39 and Table 10.

During an instruction phase, a 16-bit instruction is transmitted. Data then follows the instruction phase and is determined by the W0 and W1 bits, which is one or more bytes of data. All data is composed of 8-bit words. The first bit of each individual byte of serial data indicates whether this is a read or write

command. This allows the serial data input/output (SDIO) pin to change direction from an input to an output.

Data can be sent in MSB or in LSB first mode. MSB first is default on power-up and can be changed by changing the configuration register. For more information about this feature and others, see the AN-877 Application Note, *Interfacing to High Speed ADCs via SPI* at www.analog.com.

HARDWARE INTERFACE

The pins described in Table 8 comprise the physical interface between the programming device of the user and the serial port of the AD9484. The SCLK pin and the CSB pin function as inputs when using the SPI interface. The SDIO pin is bidirectional, functioning as an input during the write phase and as an output during readback.

This interface is flexible enough to be controlled by either PROMs or PIC® microcontrollers as well. This provides the user with an alternate method to program the ADC other than a SPI controller.

If the user chooses not to use the SPI interface, some pins serve a dual function and are associated with a specific function when strapped externally to AVDD or ground during device power-on. The Configuration Without the SPI section describes the strappable functions supported on the AD9484.

CONFIGURATION WITHOUT THE SPI

In applications that do not interface to the SPI control registers, the SCLK/DFS pin can alternately serve as a standalone CMOS-compatible control pin. Connect the CSB pin to AVDD, which disables the serial port interface.

Table 9. Mode Selection

Mnemonic	External Voltage	Configuration
SCLK/DFS	AVDD AGND	Twos complement enabled Offset binary enabled

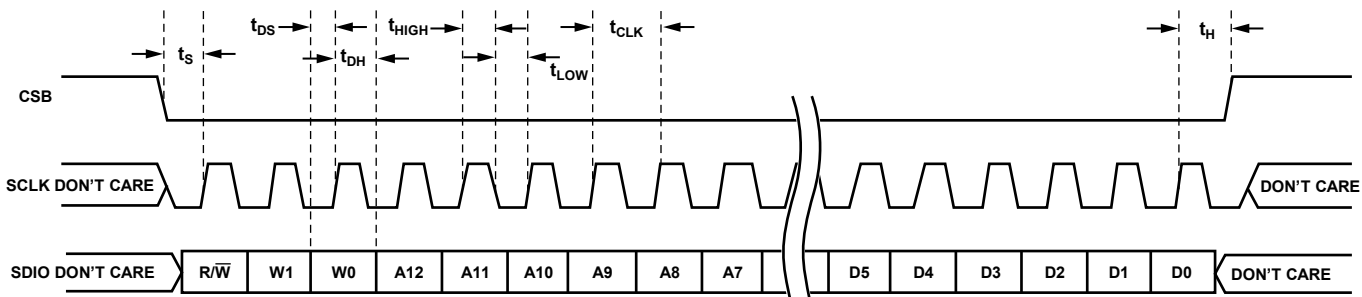

Figure 39. Serial Port Interface Timing Diagram

Table 10. Serial Timing Definitions

Parameter	Minimum (ns)	Description
t_{DS}	5	Setup time between the data and the rising edge of SCLK
t_{DH}	2	Hold time between the data and the rising edge of SCLK
t_{CLK}	40	Period of the clock
t_S	5	Setup time between CSB and SCLK
t_H	2	Hold time between CSB and SCLK
t_{HIGH}	16	Minimum period that SCLK should be in a logic high state
t_{LOW}	16	Minimum period that SCLK should be in a logic low state
t_{EN_SDIO}	1	Minimum time for the SDIO pin to switch from an input to an output relative to the SCLK falling edge (not shown in Figure 39)
t_{DIS_SDIO}	5	Minimum time for the SDIO pin to switch from an output to an input relative to the SCLK rising edge (not shown in Figure 39)

Table 11. Output Data Format

Input (V)	Condition (V)	Offset Binary Output Mode, D7± to D0±	Twos Complement Mode, D7± to D0±	OR±
VIN+ – VIN–	< –0.75 – 0.5 LSB	0000 0000	1000 0000	1
VIN+ – VIN–	= –0.75	0000 0000	1000 0000	0
VIN+ – VIN–	= 0	1000 0000	0000 0000	0
VIN+ – VIN–	= 0.75	1111 1111	0111 1111	0
VIN+ – VIN–	> 0.75 + 0.5 LSB	1111 1111	0111 1111	1

MEMORY MAP

READING THE MEMORY MAP TABLE

Each row in the memory map table (see Table 12) has eight address locations. The memory map is roughly divided into three sections: chip configuration register map (Address 0x00 to Address 0x02), transfer register map (Address 0xFF), and ADC functions register map (Address 0x08 to Address 0x2A).

The Addr. (Hex) column of the memory map indicates the register address in hexadecimal, and the Default Value (Hex) column shows the default hexadecimal value that is already written into the register. The Bit 7 (MSB) column is the start of the default hexadecimal value given. For example, Hexadecimal Address 0x2A, OVR_CONFIG, has a hexadecimal default value of 0x01. This means Bit 7 = 0, Bit 6 = 0, Bit 5 = 0, Bit 4 = 0, Bit 3 = 0, Bit 2 = 0, Bit 1 = 0, and Bit 0 = 1, or 0000 0001 in binary. The default value enables the OR± output. Overwriting this default so that Bit 0 = 0 disables the OR± output. For more information on this and other functions, consult the [AN-877](#) Application Note, *Interfacing to High-Speed ADCs via SPI®* user manual at www.analog.com.

Table 12. Memory Map Register

Addr. (Hex)	Register Name	Bit 7 (MSB)	Bit 6	Bit 5	Bit 4	Bit 3	Bit 2	Bit 1	Bit 0 (LSB)	Default Value (Hex)	Default Notes/Comments
Chip Configuration Registers											
00	CHIP_PORT_CONFIG	0	LSB first	Soft reset	1	1	Soft reset	LSB first	0	0x18	The nibbles should be mirrored by the user so that LSB or MSB first mode registers correctly, regardless of shift mode.
01	CHIP_ID	8-bit chip ID, Bits[7:0] = 0x6C								Read only	Default is a unique chip ID, different for each device. This is a read-only register.
02	CHIP_GRADE	0	0	0	Speed grade: 00 = 500 MSPS	X ¹	X ¹	X ¹	Read only	Child ID used to differentiate graded devices.	
Transfer Register											
FF	DEVICE_UPDATE	0	0	0	0	0	0	0	SW transfer	0x00	Synchronously transfers data from the master shift register to the slave.
ADC Functions Registers											
08	Modes	0	0	PDWN: 0 = full (default) 1 = standby	0	0	Internal power-down mode: 000 = normal (power-up, default) 001 = full power-down 010 = standby 011 = normal (power-up) Note that external PDWN pin overrides this setting		0x00	Determines various generic modes of chip operation.	

RESERVED LOCATIONS

Undefined memory locations should not be written to other than with the default values suggested in this data sheet. Addresses that have values marked as 0 should be considered reserved and have a 0 written into their registers during power-up.

DEFAULT VALUES

Coming out of reset, critical registers are preloaded with default values. These values are indicated in Table 12. Other registers do not have default values and retain the previous value when exiting reset.

LOGIC LEVELS

An explanation of various registers follows: “Bit is set” is synonymous with “bit is set to Logic 1” or “writing Logic 1 for the bit.” Similarly, “clear a bit” is synonymous with “bit is set to Logic 0” or “writing Logic 0 for the bit.”

Addr. (Hex)	Register Name	Bit 7 (MSB)	Bit 6	Bit 5	Bit 4	Bit 3	Bit 2	Bit 1	Bit 0 (LSB)	Default Value (Hex)	Default Notes/Comments
10	Offset	8-bit device offset adjustment [7:0] 0111 111 = +127 codes 0000 0000 = 0 codes 1000 0000 = -128 codes								0x00	Device offset trim: codes are relative to the output resolution.
0D	TEST_IO	(For user-defined mode only, set Bits[3:0] = 1000) 00 = Pattern 1 only 01 = toggle P1/P2 10 = toggle P1/0000 11 = toggle P1/P2/0000	Reset PN23 gen: 1 = on 0 = off (default)	Reset PN9 gen: 1 = on 0 = off (default)	Output test mode: 0000 = off (default) 0001 = midscale short 0010 = +FS short 0011 = -FS short 0100 = checker board output 0101 = PN23 sequence 0110 = PN9 0111 = one/zero word toggle 1000 = user defined 1001 = unused 1010 = unused 1011 = unused 1100 = unused (Format determined by OUTPUT_MODE)					0x00	When set, the test data is placed on the output pins in place of normal data. Set pattern values: P1 = Reg 0x19, Reg 0x1A P2 = Reg 0x1B, Reg 0x1C
0F	AIN_CONFIG	0	0	0	0	0	Analog input disable: 1 = on 0 = off (default)	0	0	0x00	
14	OUTPUT_MODE	0	0	0	Output enable: 0 = enable (default) 1 = disable	0	Output invert: 1 = on 0 = off (default)	Data format select: 00 = offset binary (default) 01 = twos complement 10 = Gray code		0x00	0
15	OUTPUT_ADJUST	0	0	0	0	LVDS course adjust: 0 = 3.5 mA (default) 1 = 2.0 mA	LVDS fine adjust: 001 = 3.50 mA 010 = 3.25 mA 011 = 3.00 mA 100 = 2.75 mA 101 = 2.50 mA 110 = 2.25 mA 111 = 2.00 mA			0x00	0
16	OUTPUT_PHASE	Output clock polarity 1 = inverted 0 = normal (default)	0	0	0	0	0	0	0	0x00	
17	FLEX_OUTPUT_DELAY	0	0	0	0	Output clock delay: 0000 = 0 0001 = -1/10 0010 = -2/10 0011 = -3/10 0100 = reserved 0101 = +5/10 0110 = +4/10 0111 = +3/10 1000 = +2/10 1001 = +1/10				0x00	Shown as fractional value of sampling clock period that is subtracted or added to initial t_{SKEW} , see Figure 2.

AD9484

Addr. (Hex)	Register Name	Bit 7 (MSB)	Bit 6	Bit 5	Bit 4	Bit 3	Bit 2	Bit 1	Bit 0 (LSB)	Default Value (Hex)	Default Notes/Comments
18	FLEX_VREF	VREF select 00 = internal V _{REF} (20 kΩ pull-down) 01 = import V _{REF} (0.59 V to 0.8 V on VREF pin) 10 = export V _{REF} (from internal reference) 11 = not used		0	Input voltage range setting: 11100 = 1.60 11101 = 1.58 11110 = 1.55 11111 = 1.52 00000 = 1.50 00001 = 1.47 00010 = 1.44 00011 = 1.42 00100 = 1.39 00101 = 1.36 00110 = 1.34 00111 = 1.31 01000 = 1.28 01001 = 1.26 01010 = 1.23 01011 = 1.20 01011 = 1.18					0x00	
19	USER_PATT1_LSB	B7	B6	B5	B4	B3	B2	B1	B0	0x00	User-defined pattern, 1 LSB.
1A	USER_PATT1_MSB	B7	B6	B5	B4	B3	B2	B1	B0	0x00	User-defined pattern, 1 MSB.
1B	USER_PATT2_LSB	B7	B6	B5	B4	B3	B2	B1	B0	0x00	User-defined pattern, 2 LSBs.
1C	USER_PATT2_MSB	B7	B6	B5	B4	B3	B2	B1	B0	0x00	User-defined pattern, 2 MSBs.
2A	OVR_CONFIG	0	0	0	0	0	0	0	OR± enable: 1 = on (default) 0 = off	0x01	
2C	Input coupling	0	0	0	0	0	DC coupling enable	0	0	0x00	Default is ac coupling.

¹ X = don't care.

OUTLINE DIMENSIONS

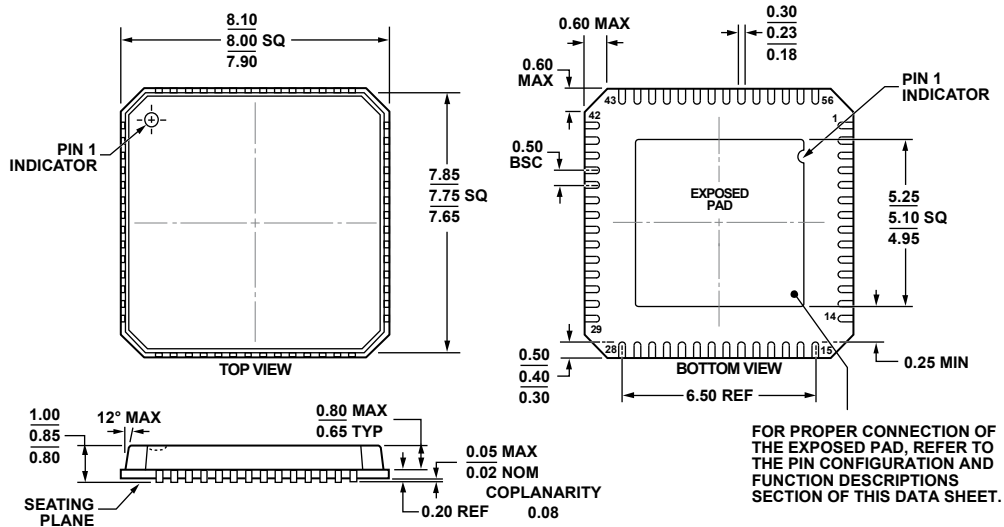

COMPLIANT TO JEDEC STANDARDS MO-220-VLLD-2
 Figure 40. 56-Lead Lead Frame Chip Scale Package [LFCSP_VQ]
 8 mm x 8 mm Body, Very Thin Quad
 (CP-56-5)
 Dimensions shown in millimeters

061609-B

ORDERING GUIDE

Model ¹	Temperature Range	Package Description	Package Option
AD9484BCPZ-500	-40°C to +85°C	56-Lead Lead Frame Chip Scale Package [LFCSP_VQ]	CP-56-5
AD9484BCPZRL7-500	-40°C to +85°C	56-Lead Lead Frame Chip Scale Package [LFCSP_VQ]	CP-56-5
AD9484-500EBZ		Evaluation Board	



¹ Z = RoHS Compliant Part.

AD9484

NOTES

Looking for pricing, stock, or lifecycle information?

Click below to explore more details on WIN SOURCE:

-  [View AD9484BCPZ-500 on WIN SOURCE](#)
-  [Analog Devices Inc. Information](#)

Optimize Your Supply Chain with WIN SOURCE Solutions

-  Global Sourcing Solution
-  Obsolete Management
-  Cost Control Management
-  Shortage Management
-  Alternative Solution
-  Excess Inventory Management