



**THE DATASHEET OF
CS8191XNF16**



CS8191

Precision Air-Core Tach/Speedo Driver with Short Circuit Protection

The CS8191 is specifically designed for use with 4 quadrant air-core meter movements. The IC includes an input comparator for sensing input frequency such as vehicle speed or engine RPM, a charge pump for frequency to voltage conversion, a bandgap reference for stable operation and a function generator with sine and cosine amplifiers that differentially drive the meter coils.

The CS8191 has a higher torque output and better output signal symmetry than other competitive parts (CS289, and LM1819). It is protected against short circuit and overvoltage (60 V) fault conditions. Enhanced circuitry permits functional operation down to 8.0 V.

Features

- Direct Sensor Input
- High Output Torque
- Wide Output Voltage Range
- High Impedance Inputs
- Accurate Down to 10 V V_{CC}
- Fault Protection
 - Overvoltage
 - Short Circuit
 - Low Voltage Operation
- Internally Fused Leads in DIP-16 and SO-20L Packages



ON Semiconductor™

<http://onsemi.com>

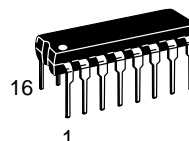

DIP-16
NF SUFFIX
CASE 648

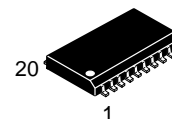

SO-20L
DWF SUFFIX
CASE 751D

PIN CONNECTIONS AND MARKING DIAGRAM

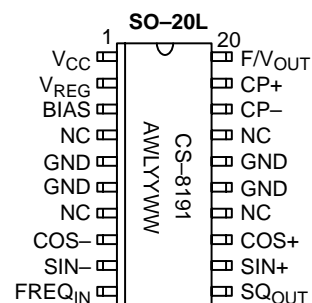
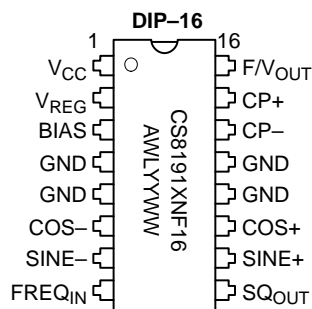

A = Assembly Location
 WL, L = Wafer Lot
 YY, Y = Year
 WW, W = Work Week

ORDERING INFORMATION

Device	Package	Shipping
CS8191XNF16	DIP-16	25 Units/Rail
CS8191XDWF20	SO-20L	37 Units/Rail
CS8191XDWFR20	SO-20L	1000 Tape & Reel

CS8191

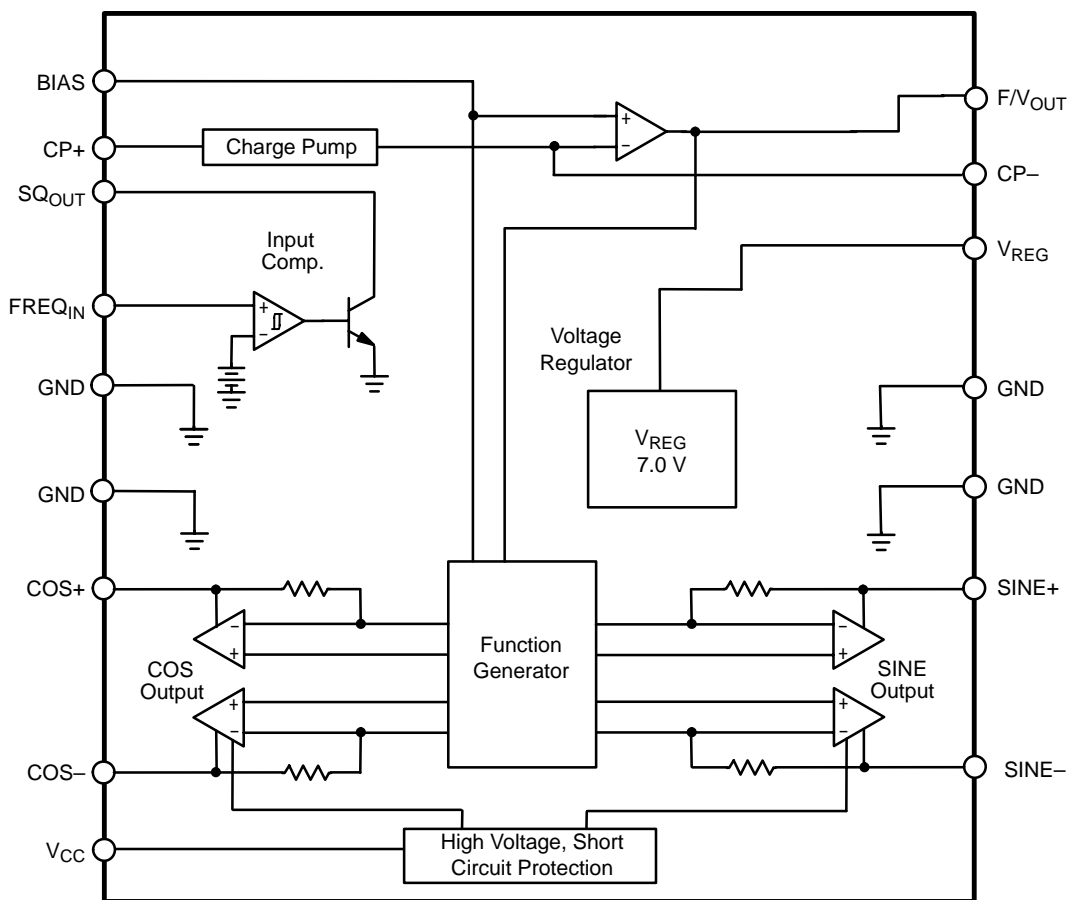

Figure 1. Block Diagram

ABSOLUTE MAXIMUM RATINGS*

Rating	Value	Unit
Supply Voltage, V_{CC}	< 100 ms Pulse Transient Continuous	60 24 V V
Operating Temperature Range	-40 to +105	°C
Junction Temperature Range	-40 to +150	°C
Storage Temperature Range	-55 to +165	°C
Electrostatic Discharge (Human Body Model)	4.0	kV
Lead Temperature Soldering:	Wave Solder (through hole styles only) (Note 1.) Reflow: (SMD styles only) (Note 2.)	260 peak 230 peak °C °C

1. 10 seconds maximum.

2. 60 second maximum above 183°C.

*The maximum package power dissipation must be observed.

CS8191

ELECTRICAL CHARACTERISTICS ($-40^{\circ}\text{C} \leq T_A \leq 105^{\circ}\text{C}$, $8.0\text{ V} \leq V_{CC} \leq 16\text{ V}$, unless otherwise specified.)

Characteristic	Test Conditions	Min	Typ	Max	Unit
----------------	-----------------	-----	-----	-----	------

Supply Voltage Section

I_{CC} Supply Current	$V_{CC} = 16\text{ V}$, -40°C , No Load	–	70	125	mA
V_{CC} Normal Operation Range	–	8.0	13.1	16	V

Input Comparator Section

Positive Input Threshold	–	2.4	2.7	3.0	V
Negative Input Threshold	–	2.0	2.3	–	V
Input Hysteresis	–	200	400	1000	mV
Input Bias Current (Note 3.)	$0\text{ V} \leq V_{IN} \leq 8.0\text{ V}$	–	–2.0	± 10	μA
Input Frequency Range	–	0	–	20	kHz
Input Voltage Range	in series with $1.0\text{ k}\Omega$	–1.0	–	V_{CC}	V
Output V_{SAT}	$I_{CC} = 10\text{ mA}$	–	0.15	0.40	V
Output Leakage	$V_{CC} = 7.0\text{ V}$	–	–	10	μA
Logic 0 Input Voltage	–	2.0	–	–	V

Voltage Regulator Section

Output Voltage	–	6.50	7.00	7.50	V
Output Load Current	–	–	–	10	mA
Output Load Regulation	0 to 10 mA	–	10	50	mV
Output Line Regulation	$8.0\text{ V} \leq V_{CC} \leq 16\text{ V}$	–	20	150	mV
Power Supply Rejection	$V_{CC} = 13.1\text{ V}$, $1.0\text{ V}_{P/P}$ 1.0 kHz	34	46	–	dB

Charge Pump Section

Inverting Input Voltage	–	1.5	2.0	2.5	V
Input Bias Current	–	–	40	150	nA
V_{BIAS} Input Voltage	–	1.5	2.0	2.5	V
Non Invert. Input Voltage	$I_{IN} = 1.0\text{ mA}$	–	0.7	1.1	V
Linearity (Note 4.)	@ 0, 87.5, 175, 262.5, + 350 Hz	–0.10	0.28	+0.70	%
F/ V_{OUT} Gain	@ 350 Hz, $C_{CP} = 0.0033\text{ }\mu\text{F}$, $R_T = 243\text{ k}\Omega$	7.0	10	13	mV/Hz
Norton Gain, Positive	$I_{IN} = 15\text{ }\mu\text{A}$	0.9	1.0	1.1	I/I
Norton Gain, Negative	$I_{IN} = 15\text{ }\mu\text{A}$	0.9	1.0	1.1	I/I

Function Generator Section: $-40^{\circ}\text{C} \leq T_A \leq 85^{\circ}\text{C}$, $V_{CC} = 13.1\text{ V}$ unless otherwise noted.

Differential Drive Voltage ($V_{COS+} - V_{COS-}$)	$10\text{ V} \leq V_{CC} \leq 16\text{ V}$ $\Theta = 0^{\circ}$	7.5	8.0	8.5	V
Differential Drive Voltage ($V_{SIN+} - V_{SIN-}$)	$10\text{ V} \leq V_{CC} \leq 16\text{ V}$ $\Theta = 90^{\circ}$	7.5	8.0	8.5	V
Differential Drive Voltage ($V_{COS+} - V_{COS-}$)	$10\text{ V} \leq V_{CC} \leq 16\text{ V}$ $\Theta = 180^{\circ}$	–8.5	–8.0	–7.5	V
Differential Drive Voltage ($V_{SIN+} - V_{SIN-}$)	$10\text{ V} \leq V_{CC} \leq 16\text{ V}$ $\Theta = 270^{\circ}$	–8.5	–8.0	–7.5	V

3. Input is clamped by an internal 12 V Zener.

4. Applies to % of full scale (270°).

CS8191

ELECTRICAL CHARACTERISTICS (continued) ($-40^{\circ}\text{C} \leq T_A \leq 105^{\circ}\text{C}$, $8.0\text{ V} \leq V_{\text{CC}} \leq 16\text{ V}$, unless otherwise specified.)

Characteristic	Test Conditions	Min	Typ	Max	Unit
Function Generator Section: $-40^{\circ}\text{C} \leq T_A \leq 85^{\circ}\text{C}$, $V_{\text{CC}} = 13.1\text{ V}$ unless otherwise noted. (continued)					
Differential Drive Load	$10\text{ V} \leq V_{\text{CC}} \leq 16\text{ V}$, -40°C	178	–	–	Ω
	25°C	239	–	–	Ω
	105°C	314	–	–	Ω
Zero Hertz Output Voltage	–	–0.08	0	+0.08	V
Function Generator Error (Note 5.) Reference Figures 2, 3, 4, 5	$\Theta = 0^{\circ}$ to 225°	–2.0	0	+2.0	deg
	$\Theta = 226^{\circ}$ to 305°	–3.0	0	+3.0	deg
Function Generator Error	$13.1\text{ V} \leq V_{\text{CC}} \leq 16\text{ V}$	–1.0	0	+1.0	deg
Function Generator Error	$13.1\text{ V} \leq V_{\text{CC}} \leq 10\text{ V}$	–1.0	0	+1.0	deg
Function Generator Error	$13.1\text{ V} \leq V_{\text{CC}} \leq 8.0\text{ V}$	–7.0	0	+7.0	deg
Function Generator Error	$25^{\circ}\text{C} \leq T_A \leq 80^{\circ}\text{C}$	–2.0	0	+2.0	deg
Function Generator Error	$25^{\circ}\text{C} \leq T_A \leq 105^{\circ}\text{C}$	–4.0	0	+4.0	deg
Function Generator Error	$-40^{\circ}\text{C} \leq T_A \leq 25^{\circ}\text{C}$	–2.0	0	+2.0	deg
Function Generator Gain	$T_A = 25^{\circ}\text{C}$, Θ vs F/V_{OUT}	60	77	95	$^{\circ}/\text{V}$

5. Deviation from nominal per Table 1 after calibration at 0° and 270° .

PIN FUNCTION DESCRIPTION

PACKAGE PIN #		PIN SYMBOL	FUNCTION
DIP-16	SO-20L		
1	1	V_{CC}	Ignition or battery supply voltage.
2	2	V_{REG}	Voltage regulator output.
3	3	BIAS	Test point or zero adjustment.
4, 5, 12, 13	5, 6, 15, 16	GND	Ground Connections.
6	8	COS-	Negative cosine output signal.
7	9	SIN-	Negative sine output signal.
8	10	FREQ_{IN}	Speed or RPM input signal.
9	11	SQ_{OUT}	Buffered square wave output signal.
10	12	SIN+	Positive sine output signal.
11	13	COS+	Positive cosine output signal.
14	18	CP-	Negative input to charge pump.
15	19	CP+	Positive input to charge pump.
16	20	F/V_{OUT}	Output voltage proportional to input signal frequency.
–	4, 7, 14, 17	NC	No connection.

TYPICAL PERFORMANCE CHARACTERISTICS

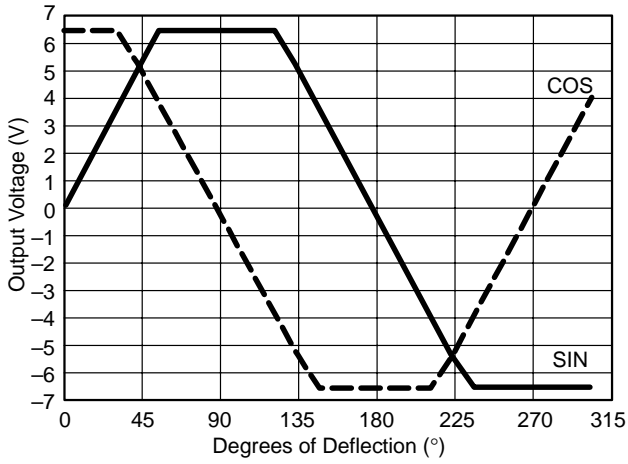

Figure 2. Function Generator Output Voltage vs. Degrees of Deflection

$$F/V_{OUT} = 2.0 V + 2.0 \times \text{FREQ} \times C_{CP} \times R_T \times (V_{REG} - 0.7 V)$$

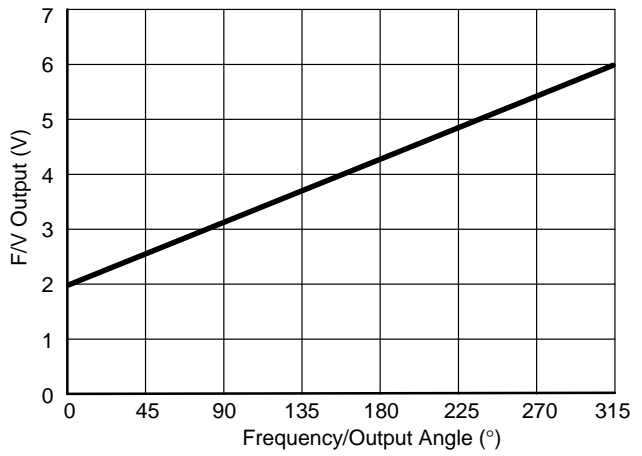

Figure 3. Charge Pump Output Voltage vs. Output Angle

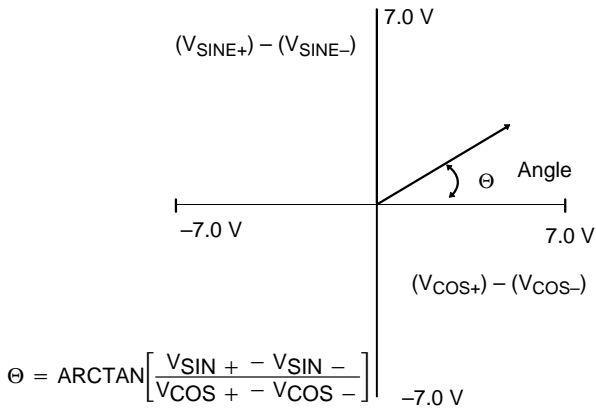

Figure 4. Output Angle in Polar Form

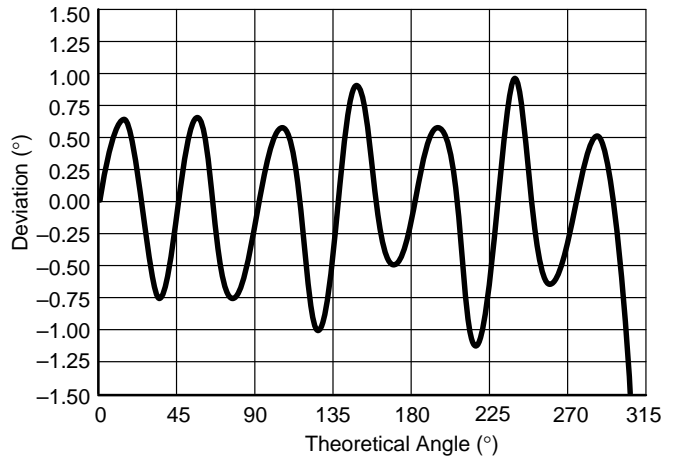

Figure 5. Nominal Output Deviation

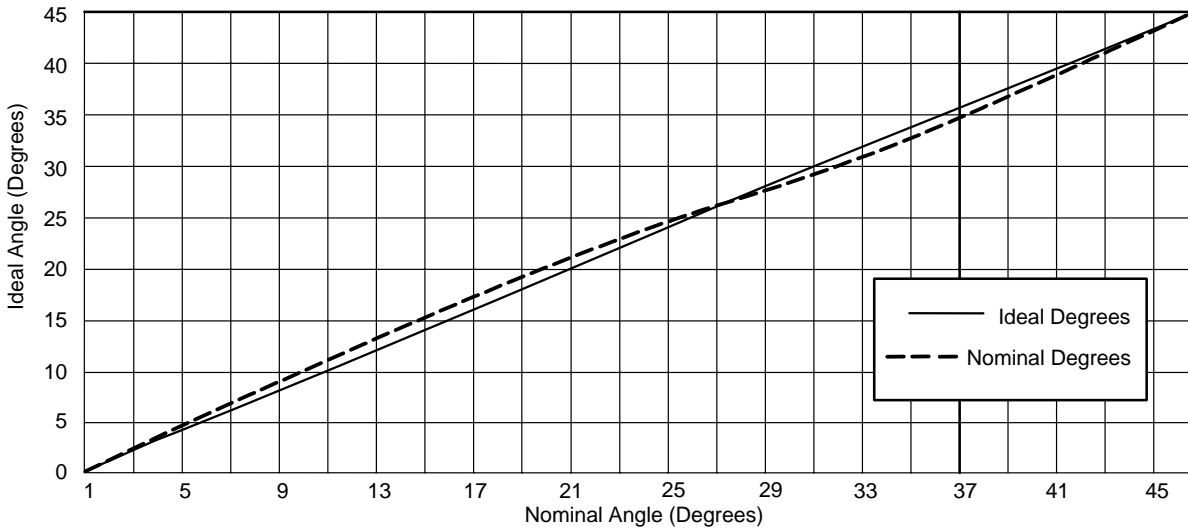

Figure 6. Nominal Angle vs. Ideal Angle (After Calibrating at 180°)

Table 1. Function Generator Output Nominal Angle vs. Ideal Angle (After Calibrating at 270°)

Ideal Θ Degrees	Nominal Θ Degrees	Ideal Θ Degrees	Nominal Θ Degrees	Ideal Θ Degrees	Nominal Θ Degrees	Ideal Θ Degrees	Nominal Θ Degrees	Ideal Θ Degrees	Nominal Θ Degrees	Ideal Θ Degrees	Nominal Θ Degrees
0	0	17	17.98	34	33.04	75	74.00	160	159.14	245	244.63
1	1.09	18	18.96	35	34.00	80	79.16	165	164.00	250	249.14
2	2.19	19	19.92	36	35.00	85	84.53	170	169.16	255	254.00
3	3.29	20	20.86	37	36.04	90	90.00	175	174.33	260	259.16
4	4.38	21	21.79	38	37.11	95	95.47	180	180.00	265	264.53
5	5.47	22	22.71	39	38.21	100	100.84	185	185.47	270	270.00
6	6.56	23	23.61	40	39.32	105	106.00	190	190.84	275	275.47
7	7.64	24	24.50	41	40.45	110	110.86	195	196.00	280	280.84
8	8.72	25	25.37	42	41.59	115	115.37	200	200.86	285	286.00
9	9.78	26	26.23	43	42.73	120	119.56	205	205.37	290	290.86
10	10.84	27	27.07	44	43.88	125	124.00	210	209.56	295	295.37
11	11.90	28	27.79	45	45.00	130	129.32	215	214.00	300	299.21
12	12.94	29	28.73	50	50.68	135	135.00	220	219.32	305	303.02
13	13.97	30	29.56	55	56.00	140	140.68	225	225.00		
14	14.99	31	30.39	60	60.44	145	146.00	230	230.58		
15	16.00	32	31.24	65	64.63	150	150.44	235	236.00		
16	17.00	33	32.12	70	69.14	155	154.63	240	240.44		

Note: Temperature, voltage and nonlinearity not included.

CIRCUIT DESCRIPTION and APPLICATION NOTES

The CS8191 is specifically designed for use with air-core meter movements. It includes an input comparator for sensing an input signal from an ignition pulse or speed sensor, a charge pump for frequency to voltage conversion, a bandgap voltage regulator for stable operation, and a function generator with sine and cosine amplifiers to differentially drive the meter coils.

From the partial schematic of Figure 7, the input signal is applied to the $FREQ_{IN}$ lead, this is the input to a high impedance comparator with a typical positive input threshold of 2.7 V and typical hysteresis of 0.4 V. The output of the comparator, SQ_{OUT} , is applied to the charge pump input $CP+$ through an external capacitor C_{CP} . When the input signal changes state, C_{CP} is charged or discharged through $R3$ and $R4$. The charge accumulated on C_{CP} is mirrored to $C4$ by the Norton Amplifier circuit comprising of $Q1$, $Q2$ and $Q3$. The charge pump output voltage, F/V_{OUT} , ranges from 2.0 V to 6.3 V depending on the input signal frequency and the gain of the charge pump according to the formula:

$$F/V_{OUT} = 2.0 V + 2.0 \times FREQ \times C_{CP} \times R_T \times (V_{REG} - 0.7 V)$$

R_T is a potentiometer used to adjust the gain of the F/V output stage and give the correct meter deflection. The F/V output voltage is applied to the function generator which generates the sine and cosine output voltages. The output voltage of the sine and cosine amplifiers are derived from the

on-chip amplifier and function generator circuitry. The various trip points for the circuit (i.e., 0°, 90°, 180°, 270°) are determined by an internal resistor divider and the bandgap voltage reference. The coils are differentially driven, allowing bidirectional current flow in the outputs, thus providing up to 305° range of meter deflection. Driving the coils differentially offers faster response time, higher current capability, higher output voltage swings, and reduced external component count. The key advantage is a higher torque output for the pointer.

The output angle, Θ , is equal to the F/V gain multiplied by the function generator gain:

$$\Theta = AF/V \times AFG,$$

where:

$$AFG = 77^\circ/V(\text{typ})$$

The relationship between input frequency and output angle is:

$$\Theta = AFG \times 2.0 \times FREQ \times C_{CP} \times R_T \times (V_{REG} - 0.7 V)$$

$$\text{or, } \Theta = 970 \times FREQ \times C_{CP} \times R_T$$

The ripple voltage at the F/V converter's output is determined by the ratio of C_{CP} and $C4$ in the formula:

$$\Delta V = \frac{C_{CP}(V_{REG} - 0.7 V)}{C4}$$

CS8191

Ripple voltage on the F/V output causes pointer or needle flutter especially at low input frequencies.

The response time of the F/V is determined by the time constant formed by R_T and C_4 . Increasing the value of C_4

will reduce the ripple on the F/V output but will also increase the response time. An increase in response time causes a very slow meter movement and may be unacceptable for many applications.

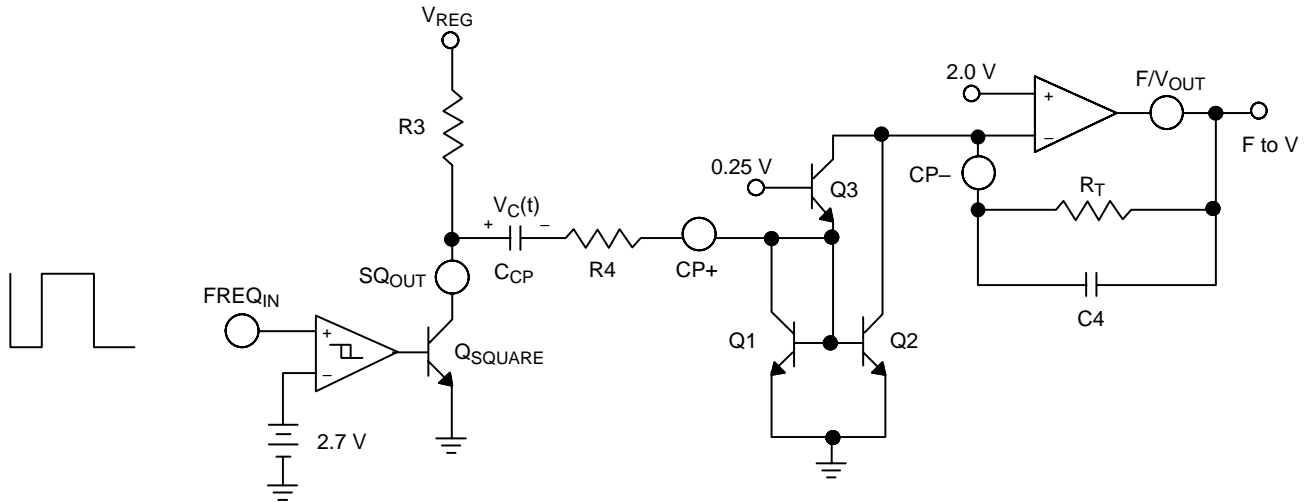

Figure 7. Partial Schematic of Input and Charge Pump

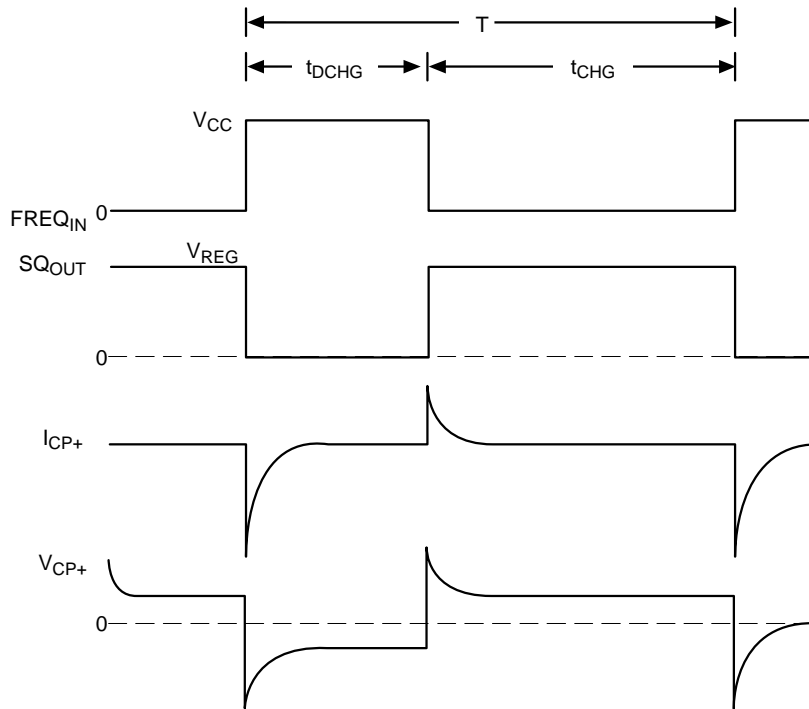
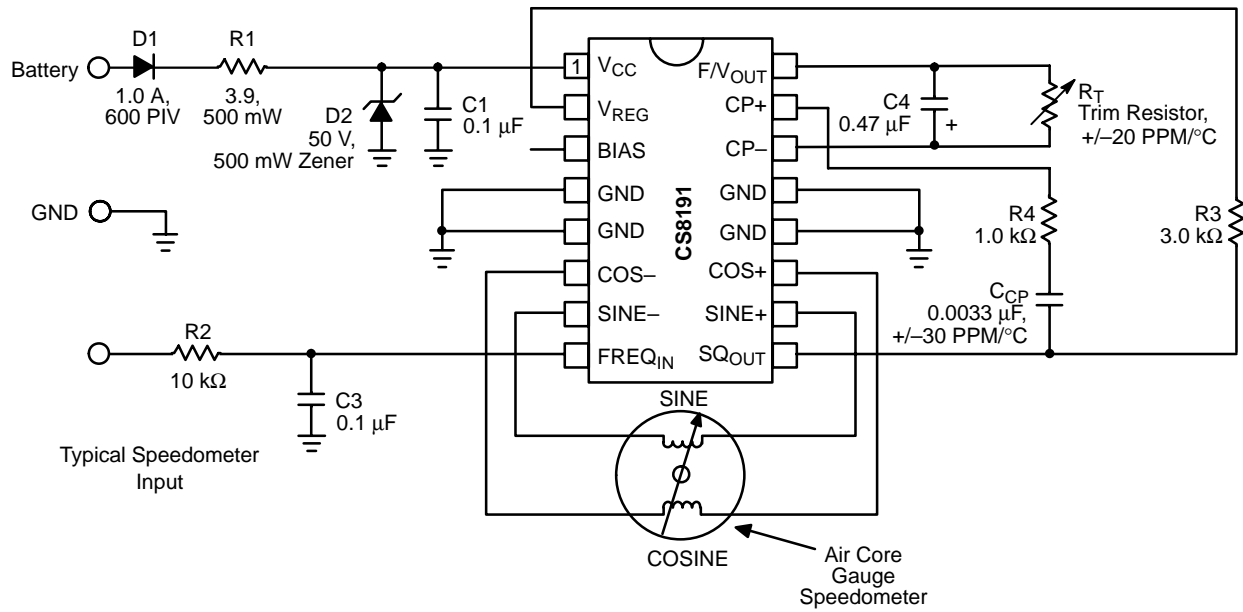

Figure 8. Timing Diagram of $FREQ_{IN}$ and I_{CP}

CS8191



Notes:

1. The product of C4 and RT have a direct effect on gain and therefore directly affect temperature compensation.
2. C4 Range; 20 pF to 0.2 μF.
3. R4 Range; 100 kΩ to 500 kΩ.
4. The IC must be protected from transients above 60 V and reverse battery conditions.
5. Additional filtering on the FREQIN lead may be required.
6. Gauge coil connections to the IC must be kept as short as possible (≤ 3.0 inch) for best pointer stability.

Figure 9. Speedometer or Tachometer Application

Design Example

Maximum meter Deflection = 270°

Maximum Input Frequency = 350 Hz

1. Select RT and CCP

$$\Theta = 970 \times \text{FREQ} \times C_{CP} \times R_T$$

Let $C_{CP} = 0.0033 \mu\text{F}$, find R_T

$$R_T = \frac{270^\circ}{970 \times 350 \text{ Hz} \times 0.0033 \mu\text{F}}$$

$$R_T = 243 \text{ k}\Omega$$

RT should be a 250 kΩ potentiometer to trim out any inaccuracies due to IC tolerances or meter movement pointer placement.

2. Select R3 and R4

Resistor R3 sets the output current from the voltage regulator. The maximum output current from the voltage regulator is 10 mA. R3 must ensure that the current does not exceed this limit.

Choose R3 = 3.3 kΩ

The charge current for C_{CP} is

$$\frac{V_{REG} - 0.7 \text{ V}}{3.3 \text{ k}\Omega} = 1.90 \text{ mA}$$

C_{CP} must charge and discharge fully during each cycle of the input signal. Time for one cycle at maximum frequency is 2.85 ms. To ensure that C_{CP} is charged, assume that the $(R3 + R4) C_{CP}$ time constant is less than 10% of the minimum input period.

$$T = 10\% \times \frac{1}{350 \text{ Hz}} = 285 \mu\text{s}$$

Choose R4 = 1.0 kΩ

Discharge time: $t_{DCHG} = R3 \times C_{CP} = 3.3 \text{ k}\Omega \times 0.0033 \mu\text{F} = 10.9 \mu\text{s}$

Charge time: $t_{CHG} = (R3 + R4)C_{CP} = 4.3 \text{ k}\Omega \times 0.0033 \mu\text{F} = 14.2 \mu\text{s}$

3. Determine C4

C4 is selected to satisfy both the maximum allowable ripple voltage and response time of the meter movement.

$$C4 = \frac{C_{CP}(V_{REG} - 0.7 \text{ V})}{\Delta V_{MAX}}$$

With C4 = 0.47 μF, the F/V ripple voltage is 44 mV.

Figure 10 shows how the CS8191 and the CS8441 are used to produce a Speedometer and Odometer circuit.

CS8191

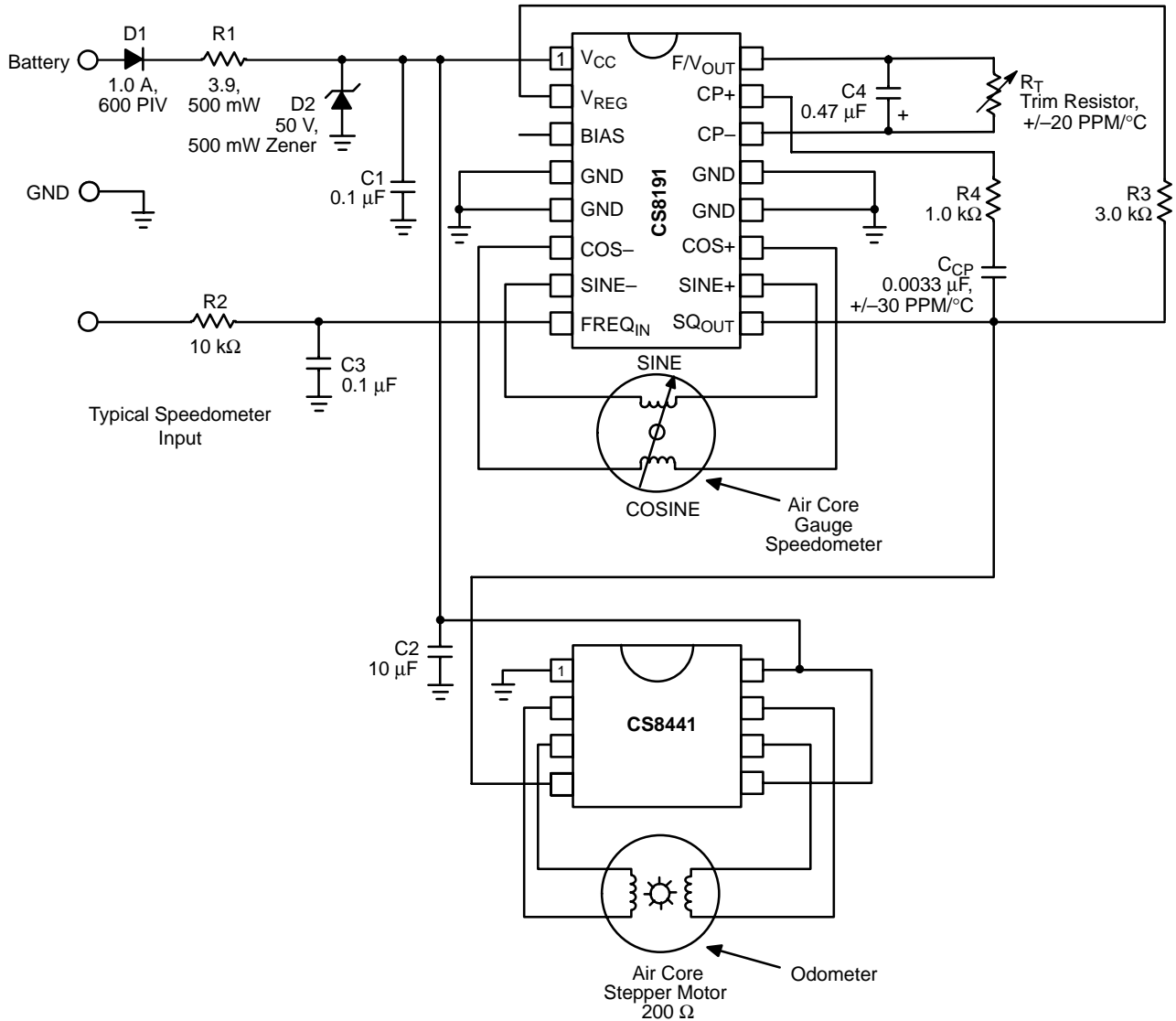

Notes:

1. The product of C4 and R_T have a direct effect on gain and therefore directly affect temperature compensation.
2. C4 Range; 20 pF to 0.2 μF.
3. R4 Range; 100 kΩ to 500 kΩ.
4. The IC must be protected from transients above 60 V and reverse battery conditions.
5. Additional filtering on the FREQ_{IN} lead may be required.
6. Gauge coil connections to the IC must be kept as short as possible (≤ 3.0 inch) for best pointer stability.

Figure 10. Speedometer With Odometer or Tachometer Application

CS8191

In some cases a designer may wish to use the CS8191 only as a driver for an air-core meter having performed the F/V conversion elsewhere in the circuit.

Figure 11 shows how to drive the CS8191 with a DC voltage ranging from 2.0 V to 6.0 V. This is accomplished by forcing a voltage on the F/V_{OUT} lead. The alternative scheme shown in Figure 12 uses an external op amp as a buffer and operates over an input voltage range of 0 V to 4.0 V.

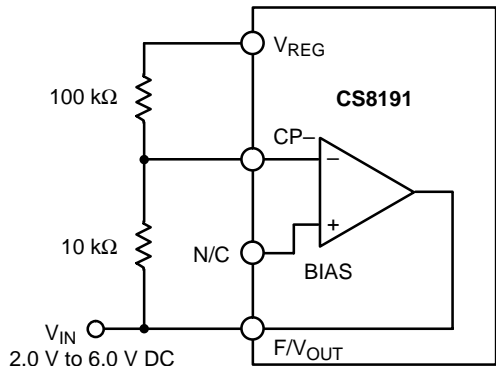

Figure 11. Driving the CS8191 from an External DC Voltage

Figures 11 and 12 are not temperature compensated.

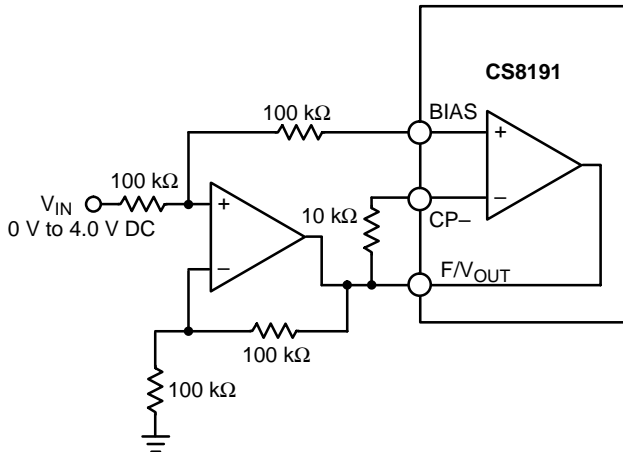
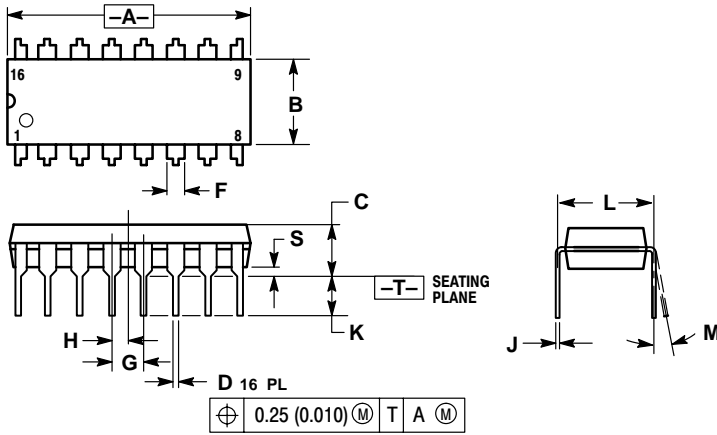

Figure 12. Driving the CS8191 from an External DC Voltage Using an Op Amp Buffer

CS8191

PACKAGE DIMENSIONS

DIP-16
NF SUFFIX
CASE 648-08
ISSUE R



NOTES:

1. DIMENSIONING AND TOLERANCING PER ANSI Y14.5M, 1982.
2. CONTROLLING DIMENSION: INCH.
3. DIMENSION L TO CENTER OF LEADS WHEN FORMED PARALLEL.
4. DIMENSION B DOES NOT INCLUDE MOLD FLASH.
5. ROUNDED CORNERS OPTIONAL.

DIM	INCHES		MILLIMETERS	
	MIN	MAX	MIN	MAX
A	0.740	0.770	18.80	19.55
B	0.250	0.270	6.35	6.85
C	0.145	0.175	3.69	4.44
D	0.015	0.021	0.39	0.53
F	0.040	0.70	1.02	1.77
G	0.100 BSC		2.54 BSC	
H	0.050 BSC		1.27 BSC	
J	0.008	0.015	0.21	0.38
K	0.110	0.130	2.80	3.30
L	0.295	0.305	7.50	7.74
M	0°	10°	0°	10°
S	0.020	0.040	0.51	1.01

SO-20L
DWF SUFFIX
CASE 751D-05
ISSUE F

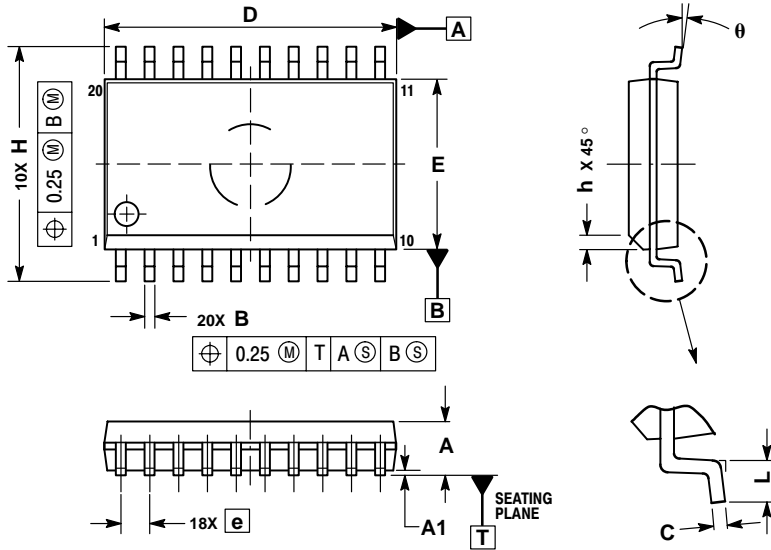

NOTES:

1. DIMENSIONS ARE IN MILLIMETERS.
2. INTERPRET DIMENSIONS AND TOLERANCES PER ASME Y14.5M, 1994.
3. DIMENSIONS D AND E DO NOT INCLUDE MOLD PROTRUSION.
4. MAXIMUM MOLD PROTRUSION 0.15 PER SIDE.
5. DIMENSION B DOES NOT INCLUDE DAMBAR PROTRUSION. ALLOWABLE PROTRUSION SHALL BE 0.13 TOTAL IN EXCESS OF B DIMENSION AT MAXIMUM MATERIAL CONDITION.

DIM	MILLIMETERS	
	MIN	MAX
A	2.35	2.65
A1	0.10	0.25
B	0.35	0.49
C	0.23	0.32
D	12.65	12.95
E	7.40	7.60
e	1.27 BSC	
H	10.05	10.55
h	0.25	0.75
L	0.50	0.90
θ	0°	7°

PACKAGE THERMAL DATA

Parameter		DIP-16	SO-20L	Unit
R _{θJC}	Typical	15	9	°C/W
R _{θJA}	Typical	50	55	°C/W

ON Semiconductor and  are trademarks of Semiconductor Components Industries, LLC (SCILLC). SCILLC reserves the right to make changes without further notice to any products herein. SCILLC makes no warranty, representation or guarantee regarding the suitability of its products for any particular purpose, nor does SCILLC assume any liability arising out of the application or use of any product or circuit, and specifically disclaims any and all liability, including without limitation special, consequential or incidental damages. "Typical" parameters which may be provided in SCILLC data sheets and/or specifications can and do vary in different applications and actual performance may vary over time. All operating parameters, including "Typicals" must be validated for each customer application by customer's technical experts. SCILLC does not convey any license under its patent rights nor the rights of others. SCILLC products are not designed, intended, or authorized for use as components in systems intended for surgical implant into the body, or other applications intended to support or sustain life, or for any other application in which the failure of the SCILLC product could create a situation where personal injury or death may occur. Should Buyer purchase or use SCILLC products for any such unintended or unauthorized application, Buyer shall indemnify and hold SCILLC and its officers, employees, subsidiaries, affiliates, and distributors harmless against all claims, costs, damages, and expenses, and reasonable attorney fees arising out of, directly or indirectly, any claim of personal injury or death associated with such unintended or unauthorized use, even if such claim alleges that SCILLC was negligent regarding the design or manufacture of the part. SCILLC is an Equal Opportunity/Affirmative Action Employer.

PUBLICATION ORDERING INFORMATION

NORTH AMERICA Literature Fulfillment:

Literature Distribution Center for ON Semiconductor
 P.O. Box 5163, Denver, Colorado 80217 USA
Phone: 303-675-2175 or 800-344-3860 Toll Free USA/Canada
Fax: 303-675-2176 or 800-344-3867 Toll Free USA/Canada
Email: ONlit@hibbertco.com
 Fax Response Line: 303-675-2167 or 800-344-3810 Toll Free USA/Canada

N. American Technical Support: 800-282-9855 Toll Free USA/Canada

EUROPE: LDC for ON Semiconductor – European Support

German Phone: (+1) 303-308-7140 (Mon-Fri 2:30pm to 7:00pm CET)
Email: ONlit-german@hibbertco.com
French Phone: (+1) 303-308-7141 (Mon-Fri 2:00pm to 7:00pm CET)
Email: ONlit-french@hibbertco.com
English Phone: (+1) 303-308-7142 (Mon-Fri 12:00pm to 5:00pm GMT)
Email: ONlit@hibbertco.com

EUROPEAN TOLL-FREE ACCESS*: 00-800-4422-3781

*Available from Germany, France, Italy, UK, Ireland

CENTRAL/SOUTH AMERICA:

Spanish Phone: 303-308-7143 (Mon-Fri 8:00am to 5:00pm MST)
Email: ONlit-spanish@hibbertco.com

ASIA/PACIFIC: LDC for ON Semiconductor – Asia Support

Phone: 303-675-2121 (Tue-Fri 9:00am to 1:00pm, Hong Kong Time)
Toll Free from Hong Kong & Singapore:
001-800-4422-3781
Email: ONlit-asia@hibbertco.com

JAPAN: ON Semiconductor, Japan Customer Focus Center

4-32-1 Nishi-Gotanda, Shinagawa-ku, Tokyo, Japan 141-0031
Phone: 81-3-5740-2745
Email: r14525@onsemi.com

ON Semiconductor Website: <http://onsemi.com>

For additional information, please contact your local Sales Representative.

Looking for pricing, stock, or lifecycle information?

Click below to explore more details on WIN SOURCE:

 [View CS8191XNF16 on WIN SOURCE](#)

 [ON Semiconductor](#) Information

Optimize Your Supply Chain with WIN SOURCE Solutions

-  Global Sourcing Solution
-  Obsolete Management
-  Cost Control Management
-  Shortage Management
-  Alternative Solution
-  Excess Inventory Management