

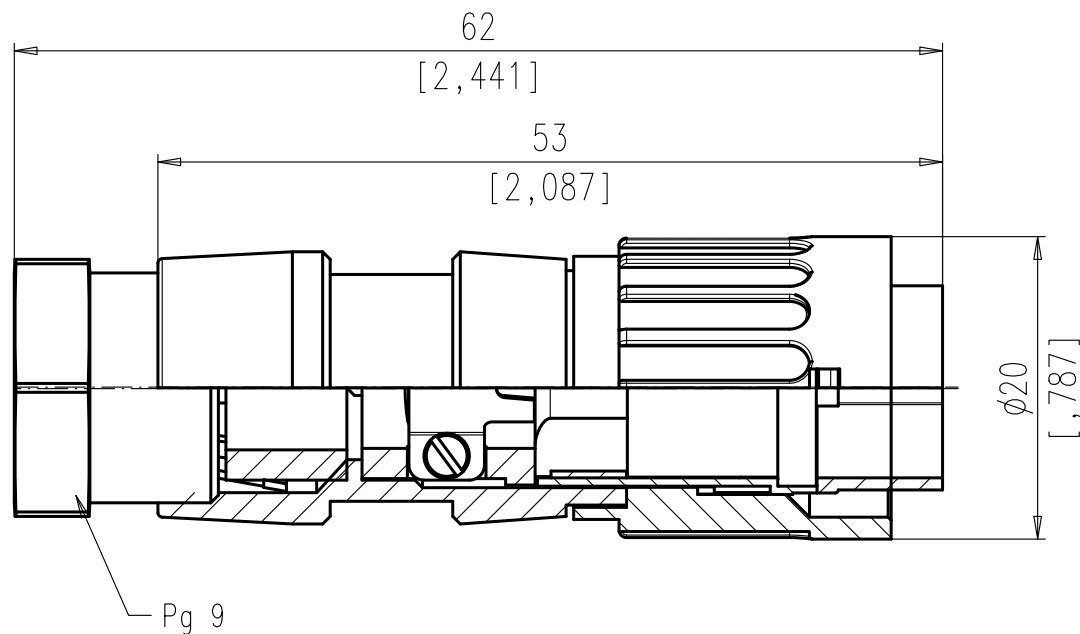

**THE DATASHEET OF
T 3424 552**



Copying of this document and giving it to others and the use or communication of the contents thereof, are forbidden without express authority. Offenders are liable to the payment of damages. All rights are reserved in the event of the grant of a patent or the registration of the utility model or design.



Polzahl number of contacts	Norm standard	3	4	5	5	6	7	7	8	12	14	
D Kontaktanordnung nach DIN contact arrangement acc. to DIN Kontaktanordnung nach IEC contact arrangement acc. to IEC		41524 60130-9	- 60130-9	- -	41524 60130-9	45322 60130-9	- -	45329 60130-9	45326 60130-9	- -	- -	
Bemessungsspannung rated voltage	IEC 60664-1	300V =		100V =	300V =		100V =		150V =			
Bemessungsspannung rated voltage	UL 1977	250V										60V
Bemessungs-Stoßspannung rated impulse withstand voltage	IEC 60664-1	1500V		1200V	1500V		1200V					
Verschmutzungsgrad pollution degree	IEC 60664-1	1										
Überspannungskategorie installation category	IEC 60664-1	I										
C Isolierstoffgruppe insulation group	IEC 60664-1	II, 400 ≤ CTI < 600										
Strombelastbarkeit current rating	IEC 60512-5-2 Test 5b UL 1977	5A / +40°C / +104°F								3A / +40°C / +104°F		
Isolationswiderstand insulation resistance	IEC 60512-3-1 Test 3a	>10 ¹⁰ Ω										
Durchgangswiderstand contact resistance	IEC 60512-2-1 Test 2a	< 5m Ω										
Prüfklasse climatic category	IEC 60068-1	40 / 100 / 56										
Temperaturbereich temperatur range	IEC 60068-1	-40°C ... +100°C -40°F ... +212°F										
B IP-Schutzart IP-degree	IEC 60529	IP 40										
Steck- und Ziehkraft Insertion and withdrawal forces	IEC 60512-13-2 Test 13b	25N 90.oz	30N 110.oz	35N 125.oz	50N 180.oz	55N 200.oz	60N 220.oz	50N 180.oz				
Mechanische Lebensdauer mechanical operation	IEC 60512-9-1 Test 9a	silber/silver ≥ 500 Steckzyklen/mating cycles gold/gold ≥ 1000 Steckzyklen/mating cycles										
Werkstoff Gehäuse housing material		Überwurfmutter Messing, Zugentlastung Zink-Druckguß? Oberfläche vernickelt coupling ring brass, strain relief, die cast, nickel plated										
Werkstoff Kontaktträger dielectric material		Thermoplast thermoplastic										
Kontaktoberfläche contact plating		versilbert/vergoldet silver plated/gold plated										
Anschlussstechnik termination technique		crimpen crimp										
A Anschlussquerschnitt wire gauge		crimp: 2-6 pol(ausschließlich/excluding 5S): 0,09-1,00mm ² / 28-18 AWG crimp 5S, 7, 7S, 8 pol: 0,09-0,75mm ² / 28-20 AWG										
Brennbarkeit flammability		UL 94 V0										
Verriegelung locking system		Bajonett bayonet										

All technical data have been measured in a laboratory environment and can be different during practical usage of the product. Any product information is for descriptive usage only and not legally binding; particularly the information does not constitute or provide any legal guaranties ("Beschaffenheitsgarantie" or "Haltbarkeitsgarantie")

Do not connect or disconnect under load. Metal housing parts shall be securely incorporated to protected ground.
 please ordner crimp contacts separately. Details see M-N 01 015 00XX (X) or catalog C091 A/B/D page 44

	14	-
	12	-
	8 IEC	T 3524 552 U
	7 IEC	T 3444 552 U
	7	T 3434 552 U
	6	T 3424 552 U
	5	T 3374 552 U
	5 IEC	T 3394 552 U
	4	T 3324 552 U
	3	T 3274 552 U
SYMBOL symbol	POLZAHL number of contacts	TYP-NUMMER-CRIMP type-number-crimp

Gewicht (errechnet)/ Calc WT:	9	Zul. Abw./Tolerances:		Maßstab/Scale	2:1	A3	
Prüfmaß/Testdimension		DIN/ISO	13715	CUSTOMER DRAWING			
Teileindex Part index number		12	Datum/Date	Name	Kabelstecker gerade Male cable connector		
		Gez.	05.01.	Aaron.Liu			
		Drawn					
		Gep.					
		Checked					
Amphenol-Tuchel Electronics GmbH		M		HB T 3XX4 552 U		Blatt/Sheet 1 1 Bl.	
01	201200011	05.01.12	AL	Ers. f./Similar to:			
Index	Änderung/Description	Datum/Date	Name				

Weitergabe sowie Vervielfältigung dieser Unterlage, Verwertung und Mitteilung ihres Inhalts nicht gestattet, soweit nicht ausdrücklich zugestanden. Zuwiderhandlungen verpflichten zu Schadenersatz. Alle Rechte für den Fall der Patenterteilung oder Gebrauchsmuster-Eintragung vorbehalten.

Looking for pricing, stock, or lifecycle information?

Click below to explore more details on WIN SOURCE:

 [View T 3424 552 on WIN SOURCE](#)

 [Amphenol Information](#)

Optimize Your Supply Chain with WIN SOURCE Solutions

-  Global Sourcing Solution
-  Obsolete Management
-  Cost Control Management
-  Shortage Management
-  Alternative Solution
-  Excess Inventory Management