



**THE DATASHEET OF
CSD16407Q5C**





DualCool™ N-Channel NexFET™ Power MOSFET

 Check for Samples: [CSD16407Q5C](#)

FEATURES

- **Ultralow Q_g and Q_{gd}**
- **DualCool™ Package**
- **Optimized for Two Sided Cooling**
- **Avalanche Rated**
- **Pb Free Terminal Plating**
- **RoHS Compliant**
- **Halogen Free**
- **SON 5-mm x 6-mm Plastic Package**

APPLICATIONS

- **Point-of-Load Synchronous Buck Converter for Applications in Networking, Telecom and Computing Systems**
- **Optimized for Synchronous FET Applications**

DESCRIPTION

The NexFET™ power MOSFET has been designed to minimize losses in power conversion applications.

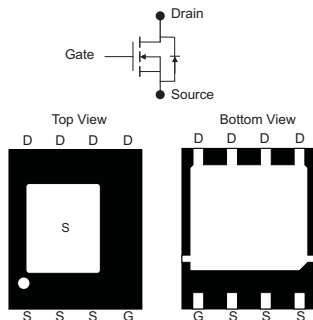

PRODUCT SUMMARY

| | | | |
|--------------|-------------------------------|-----------------|--------|
| V_{DS} | Drain to Source Voltage | 25 | V |
| Q_g | Gate Charge Total (4.5V) | 13.3 | nC |
| Q_{gd} | Gate Charge Gate to Drain | 3.5 | nC |
| $R_{DS(on)}$ | Drain to Source On Resistance | $V_{GS} = 4.5V$ | 2.5 mΩ |
| | | $V_{GS} = 10V$ | 1.8 mΩ |
| $V_{(th)}$ | Threshold Voltage | 1.6 | V |

ORDERING INFORMATION

| Device | Package | Media | Qty | Ship |
|-------------|---------------------------------|--------------|------|---------------|
| CSD16407Q5C | SON 5-mm x 6-mm Plastic Package | 13-Inch Reel | 2500 | Tape and Reel |

ABSOLUTE MAXIMUM RATINGS

| $T_A = 25^\circ\text{C}$ unless otherwise stated | | VALUE | UNIT |
|--|---|------------|------|
| V_{DS} | Drain to Source Voltage | 25 | V |
| V_{GS} | Gate to Source Voltage | +16 / -12 | V |
| I_D | Continuous Drain Current, $T_C = 25^\circ\text{C}$ | 100 | A |
| | Continuous Drain Current ⁽¹⁾ | 31 | A |
| I_{DM} | Pulsed Drain Current, $T_A = 25^\circ\text{C}$ ⁽²⁾ | 200 | A |
| P_D | Power Dissipation ⁽¹⁾ | 3.1 | W |
| T_J, T_{STG} | Operating Junction and Storage Temperature Range | -55 to 150 | °C |
| E_{AS} | Avalanche Energy, single pulse $I_D = 66A, L = 0.1\text{mH}, R_G = 25\Omega$ | 218 | mJ |

(1) Typical $R_{\theta JA} = 40^\circ\text{C/W}$ on 1-inch² (6.45-cm²), 2-oz. (0.071-mm thick) Cu pad on a 0.06-inch (1.52-mm) thick FR4 PCB.

(2) Pulse duration $\leq 300\mu\text{s}$, duty cycle $\leq 2\%$

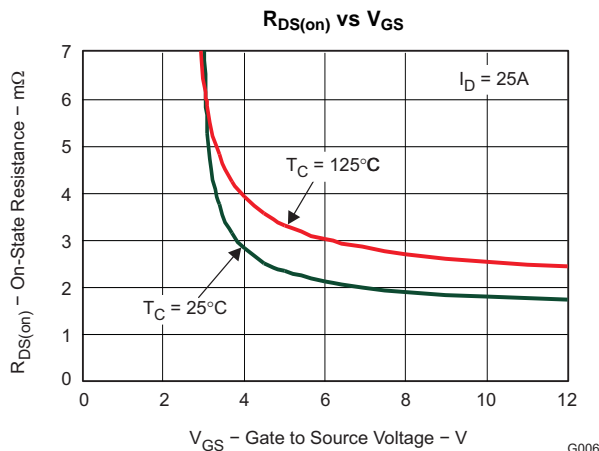

G006

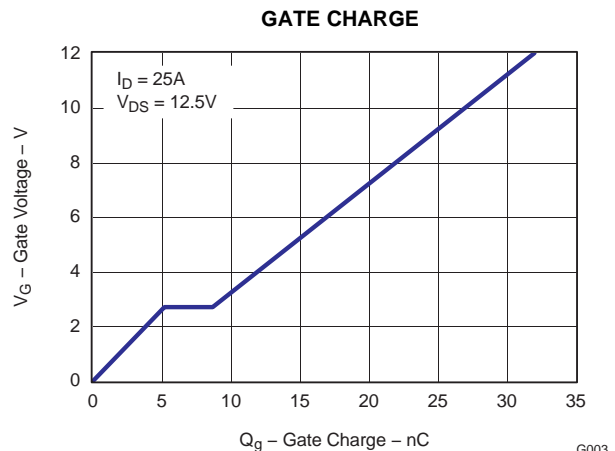

G003



Please be aware that an important notice concerning availability, standard warranty, and use in critical applications of Texas Instruments semiconductor products and disclaimers thereto appears at the end of this data sheet.

DualCool, NexFET are trademarks of Texas Instruments.



These devices have limited built-in ESD protection. The leads should be shorted together or the device placed in conductive foam during storage or handling to prevent electrostatic damage to the MOS gates.

ELECTRICAL CHARACTERISTICS

$T_A = 25^\circ\text{C}$, unless otherwise specified

| PARAMETER | | TEST CONDITIONS | MIN | TYP | MAX | UNIT |
|--------------------------------|----------------------------------|---|-----|------|------|------------|
| Static Characteristics | | | | | | |
| BV_{DSS} | Drain to Source Voltage | $V_{GS} = 0V, I_D = 250\mu A$ | 25 | | | V |
| I_{DSS} | Drain to Source Leakage Current | $V_{GS} = 0V, V_{DS} = 20V$ | | | 1 | μA |
| I_{GSS} | Gate to Source Leakage Current | $V_{DS} = 0V, V_{GS} = +16V / -12V$ | | | 100 | nA |
| $V_{GS(th)}$ | Gate to Source Threshold Voltage | $V_{DS} = V_{GS}, I_D = 250\mu A$ | 1.3 | 1.6 | 1.9 | V |
| $R_{DS(on)}$ | Drain to Source On Resistance | $V_{GS} = 4.5V, I_D = 25A$ | | 2.5 | 3.3 | m Ω |
| | | $V_{GS} = 10V, I_D = 25A$ | | 1.8 | 2.4 | m Ω |
| g_{fs} | Transconductance | $V_{DS} = 15V, I_D = 25A$ | | 111 | | S |
| Dynamic Characteristics | | | | | | |
| C_{ISS} | Input Capacitance | $V_{GS} = 0V, V_{DS} = 12.5V, f = 1MHz$ | | 2040 | 2660 | pF |
| C_{OSS} | Output Capacitance | | | 1600 | 2080 | pF |
| C_{RSS} | Reverse Transfer Capacitance | | | 115 | 160 | pF |
| R_g | Series Gate Resistance | | | 1.2 | 2.4 | Ω |
| Q_g | Gate Charge Total (4.5V) | $V_{DS} = 12.5V, I_D = 25A$ | | 13.3 | 18 | nC |
| Q_{gd} | Gate Charge Gate to Drain | | | 3.5 | | nC |
| Q_{gs} | Gate Charge Gate to Source | | | 5.3 | | nC |
| $Q_{g(th)}$ | Gate Charge at V_{th} | | | 3.1 | | nC |
| Q_{OSS} | Output Charge | $V_{DS} = 13.5V, V_{GS} = 0V$ | | 33 | | nC |
| $t_{d(on)}$ | Turn On Delay Time | $V_{DS} = 12.5V, V_{GS} = 4.5V, I_D = 25A, R_G = 2\Omega$ | | 11.9 | | ns |
| t_r | Rise Time | | | 18.4 | | ns |
| $t_{d(off)}$ | Turn Off Delay Time | | | 16 | | ns |
| t_f | Fall Time | | | 9 | | ns |
| Diode Characteristics | | | | | | |
| V_{SD} | Diode Forward Voltage | $I_S = 25A, V_{GS} = 0V$ | | 0.8 | 1 | V |
| Q_{rr} | Reverse Recovery Charge | $V_{DD} = 13.5V, I_F = 25A, di/dt = 300A/\mu s$ | | 42 | | nC |
| t_{rr} | Reverse Recovery Time | $V_{DD} = 13.5V, I_F = 25A, di/dt = 300A/\mu s$ | | 34 | | ns |

THERMAL CHARACTERISTICS

$T_A = 25^\circ\text{C}$, unless otherwise specified

| PARAMETER | | MIN | TYP | MAX | UNIT |
|-----------------|---|-----|-----|-----|--------------------|
| $R_{\theta JC}$ | Thermal Resistance Junction to Case (Top Source) ⁽¹⁾ | | | 1.2 | $^\circ\text{C/W}$ |
| $R_{\theta JC}$ | Thermal Resistance Junction to Case (Bottom Drain) ⁽¹⁾ | | | 1.1 | $^\circ\text{C/W}$ |
| $R_{\theta JA}$ | Thermal Resistance Junction to Ambient ^{(1) (2)} | | | 51 | $^\circ\text{C/W}$ |

(1) $R_{\theta JC}$ is determined with the device mounted on a 1-inch² (6.45-cm²), 2-oz. (0.071-mm thick) Cu pad on a 1.5-inch × 1.5-inch (3.81-cm × 3.81-cm), 0.06-inch (1.52-mm) thick FR4 PCB. $R_{\theta JC}$ is specified by design, whereas $R_{\theta JA}$ is determined by the user's board design.

(2) Device mounted on FR4 material with 1-inch² (6.45-cm²), 2-oz. (0.071-mm thick) Cu.

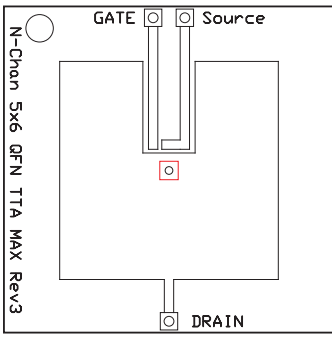

M0137-01

Max $R_{\theta JA} = 51^{\circ}\text{C/W}$
when mounted on
1 inch² (6.45 cm²) of
2-oz. (0.071-mm thick)
Cu.

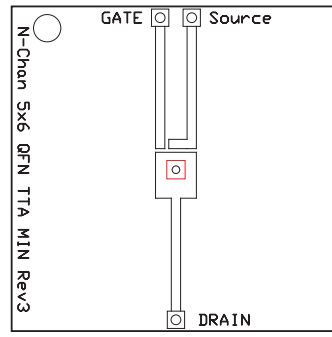

M0137-02

Max $R_{\theta JA} = 121^{\circ}\text{C/W}$
when mounted on
minimum pad area of
2-oz. (0.071-mm thick)
Cu.

TYPICAL MOSFET CHARACTERISTICS

$T_A = 25^{\circ}\text{C}$, unless otherwise specified

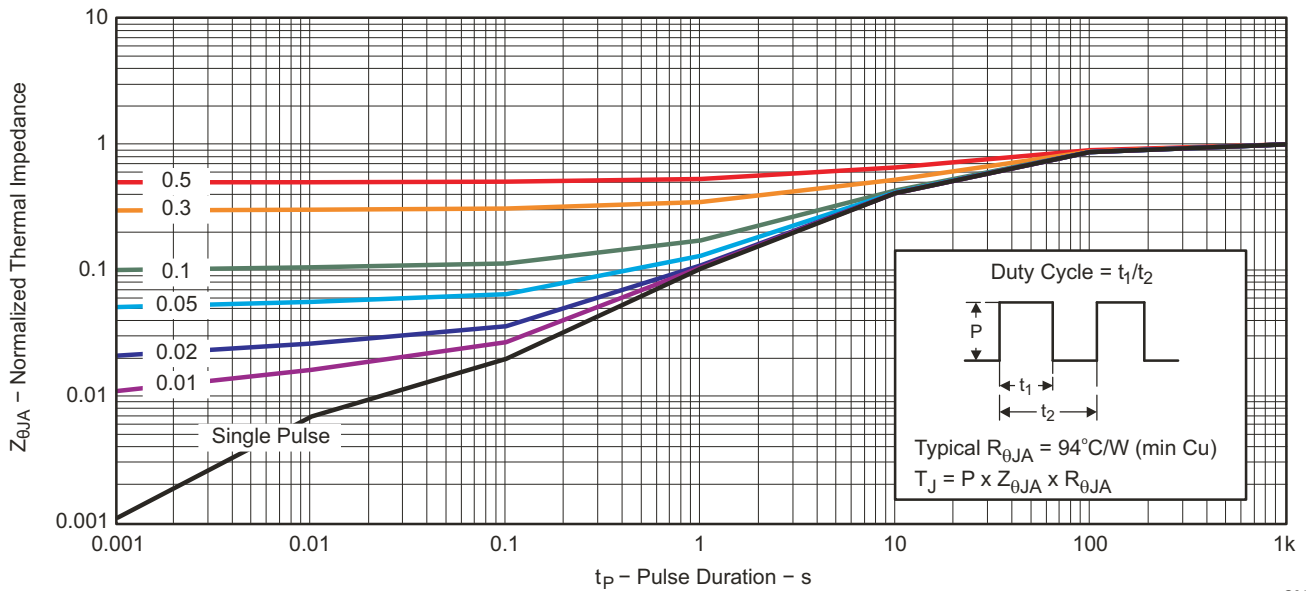

G012

Figure 1. Transient Thermal Impedance

TYPICAL MOSFET CHARACTERISTICS (continued)

T_A = 25°C, unless otherwise specified

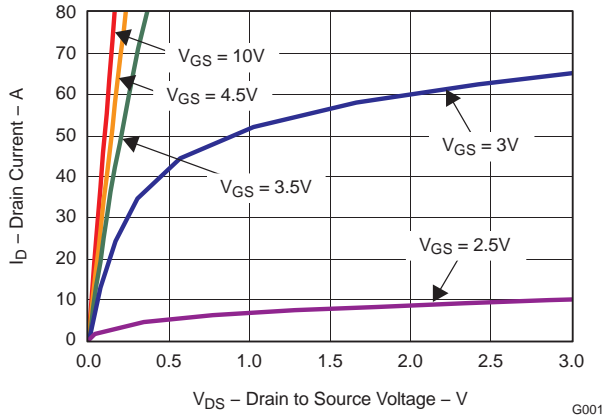

Figure 2. Saturation Characteristics

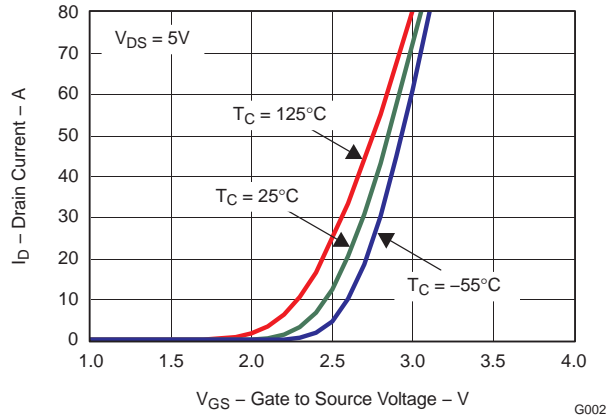

Figure 3. Transfer Characteristics

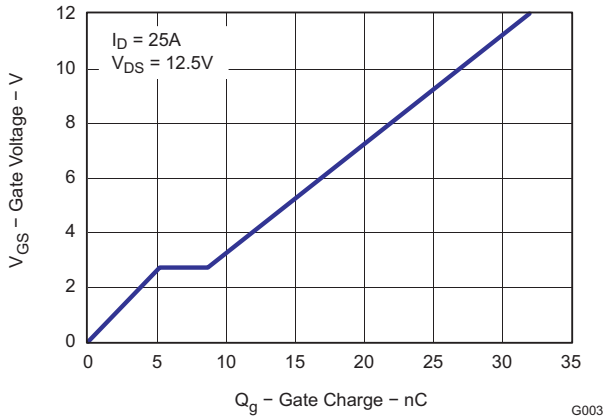

Figure 4. Gate Charge

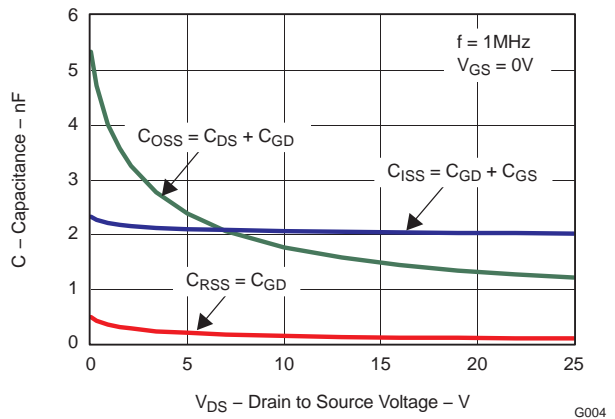

Figure 5. Capacitance

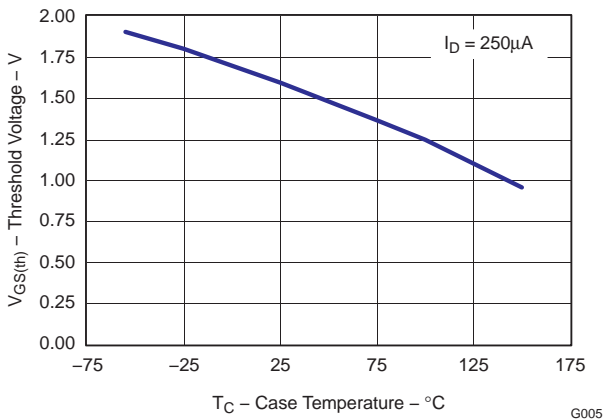

Figure 6. Threshold Voltage vs. Temperature

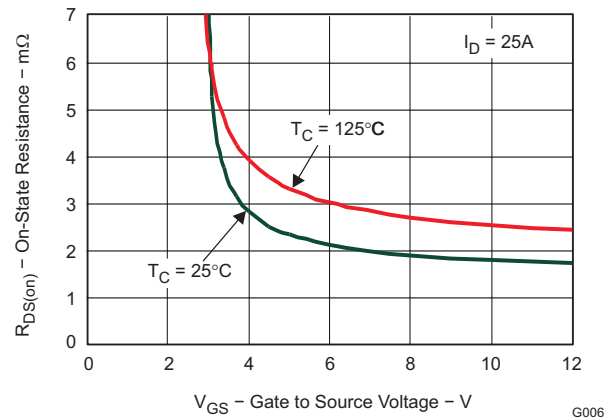

Figure 7. On-State Resistance vs. Gate to Source Voltage

TYPICAL MOSFET CHARACTERISTICS (continued)

T_A = 25°C, unless otherwise specified

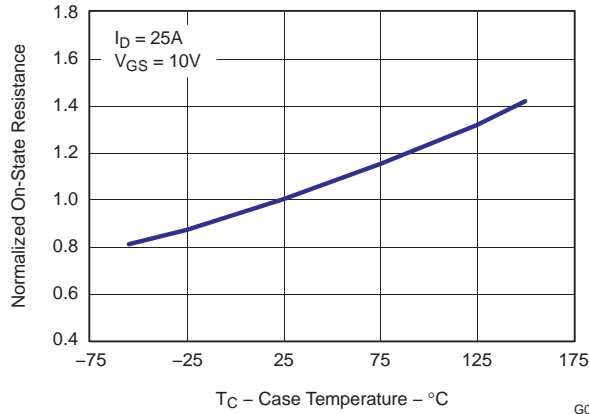

Figure 8. Normalized On-State Resistance vs. Temperature

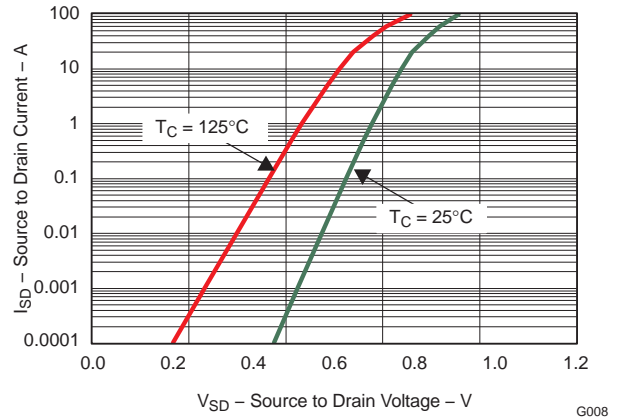

Figure 9. Typical Diode Forward Voltage

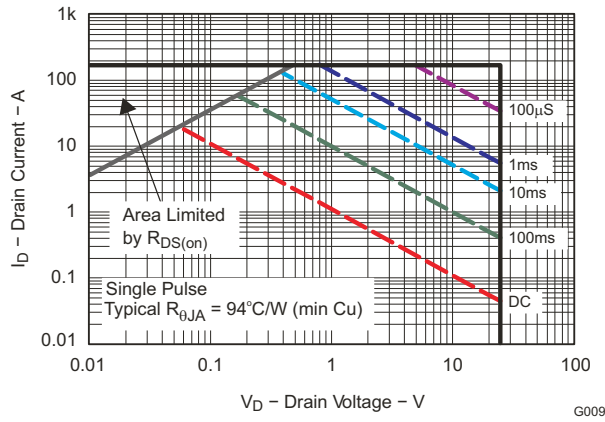

Figure 10. Maximum Safe Operating Area

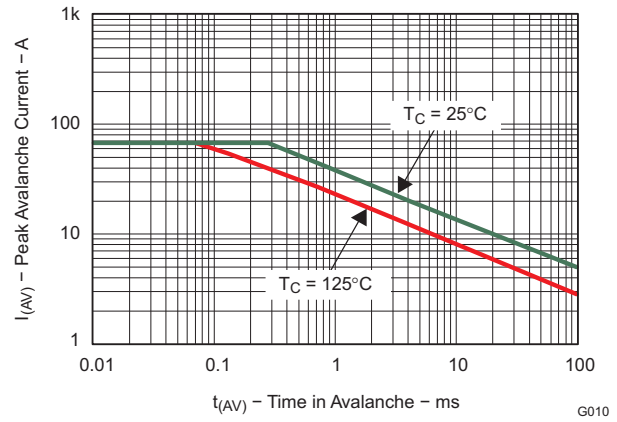

Figure 11. Single Pulse Unclamped Inductive Switching

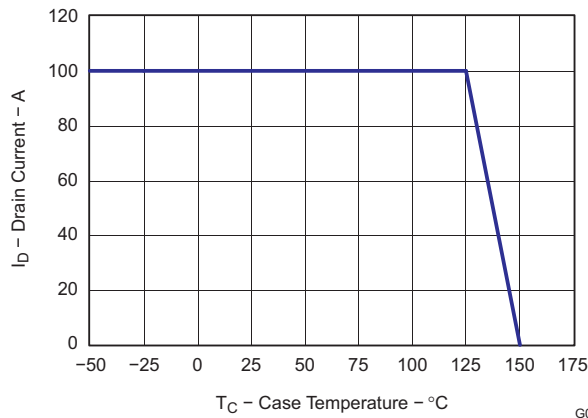
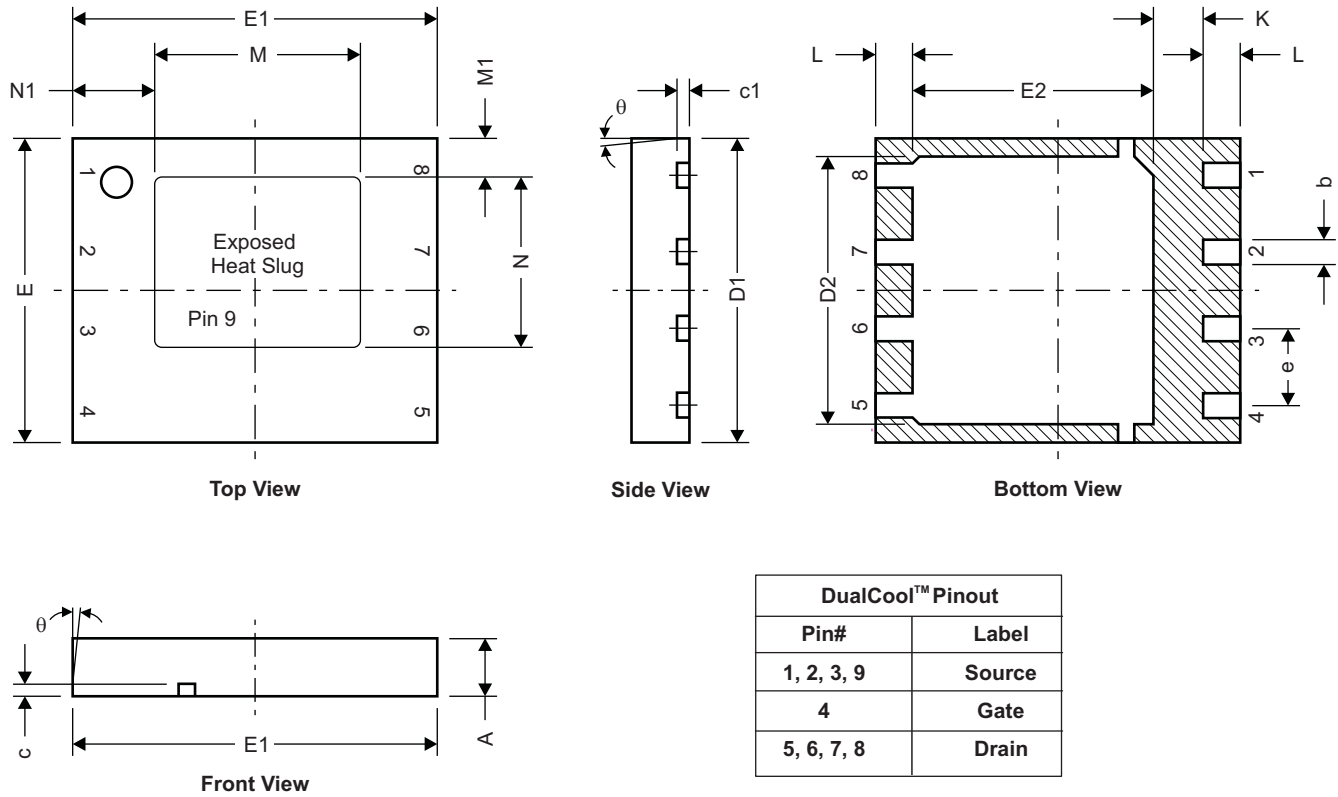

Figure 12. Maximum Drain Current vs. Temperature

MECHANICAL DATA

Q5C Package Dimensions



| DualCool™ Pinout | |
|------------------|--------|
| Pin# | Label |
| 1, 2, 3, 9 | Source |
| 4 | Gate |
| 5, 6, 7, 8 | Drain |

M0162-01

| DIM | MILLIMETERS | | INCHES | |
|-------|-------------|-------|--------|-------|
| | MIN | MAX | MIN | MAX |
| A | 0.950 | 1.050 | 0.037 | 0.039 |
| b | 0.360 | 0.460 | 0.014 | 0.018 |
| c | 0.150 | 0.250 | 0.006 | 0.010 |
| c1 | 0.150 | 0.250 | 0.006 | 0.010 |
| D1 | 4.900 | 5.100 | 0.193 | 0.201 |
| D2 | 4.320 | 4.520 | 0.170 | 0.178 |
| E | 4.900 | 5.100 | 0.193 | 0.201 |
| E1 | 5.900 | 6.100 | 0.232 | 0.240 |
| E2 | 3.920 | 4.12 | 0.154 | 0.162 |
| e | 1.27 TYP | | 0.050 | |
| K | 0.760 | – | 0.030 | – |
| L | 0.510 | 0.710 | 0.020 | 0.028 |
| theta | – | – | – | – |
| M | 3.260 | 3.460 | 0.128 | 0.136 |
| M1 | 0.520 | 0.720 | 0.020 | 0.028 |
| N | 2.720 | 2.920 | 0.107 | 0.115 |
| N1 | 1.227 | 1.427 | 0.048 | 0.056 |

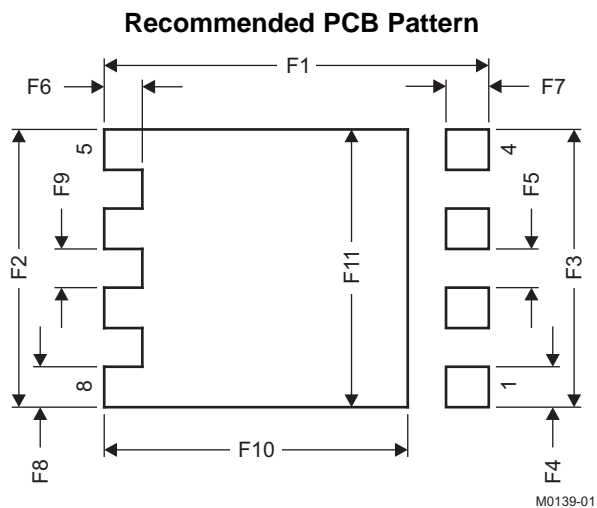

| DIM | MILLIMETERS | | INCHES | |
|-----|-------------|-------|--------|-------|
| | MIN | MAX | MIN | MAX |
| F1 | 6.205 | 6.305 | 0.244 | 0.248 |
| F2 | 4.460 | 4.560 | 0.176 | 0.180 |
| F3 | 4.460 | 4.560 | 0.176 | 0.180 |
| F4 | 0.650 | 0.700 | 0.026 | 0.028 |
| F5 | 0.620 | 0.670 | 0.024 | 0.026 |
| F6 | 0.630 | 0.680 | 0.025 | 0.027 |
| F7 | 0.700 | 0.800 | 0.028 | 0.031 |
| F8 | 0.650 | 0.700 | 0.026 | 0.028 |
| F9 | 0.620 | 0.670 | 0.024 | 0.026 |
| F10 | 4.900 | 5.000 | 0.193 | 0.197 |
| F11 | 4.460 | 4.560 | 0.176 | 0.180 |

For recommended circuit layout for PCB designs, see application note [SLPA005 – Reducing Ringing Through PCB Layout Techniques](#).

Q5C Tape and Reel Information

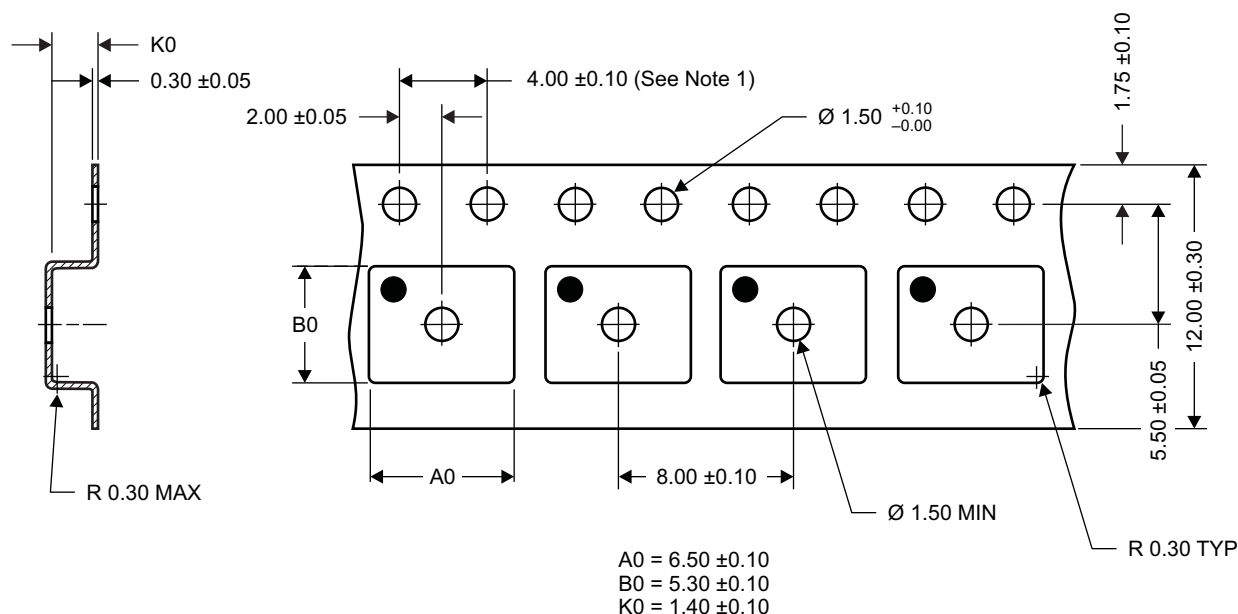

Notes:

- 10-sprocket hole-pitch cumulative tolerance ± 0.2
- Camber not to exceed 1mm in 100mm, noncumulative over 250mm
- Material: black static-dissipative polystyrene
- All dimensions are in mm, unless otherwise specified.
- Thickness: 0.30 ± 0.05 mm
- MSL1 260°C (IR and convection) PbF reflow compatible

M0138-01

REVISION HISTORY

| Changes from Original (October 2009) to Revision A | Page |
|--|-------------|
| • Changed the device From: Procut Preview To: Production | 1 |
| • Changed Application - From: Optimized for Control FET Applications To: Optimized for Synchronous FET Applications | 1 |
| • Changed the pinout illustration. | 1 |
| • Changed the Q5C Package Dimensions illustration | 6 |
| Changes from Revision A (December 2009) to Revision B | Page |
| • Changed the ABSOLUTE MAXIMUM RATINGS table, I_D - Continuous Drain Current value From: 30A To: 31A | 1 |
| • Changed Note 1 of the ABSOLUTE MAXIMUM RATINGS table From: Typical $R_{\theta JA} = 41^\circ\text{C}$ To: Typical $R_{\theta JA} = 40^\circ\text{C}$ | 1 |
| • Changed Figure 1 - From: Typical $R_{\theta JA} = 98^\circ\text{C/W}$ To: Typical $R_{\theta JA} = 94^\circ\text{C/W}$ | 3 |
| • Changed Figure 10 - From: Typical $R_{\theta JA} = 98^\circ\text{C/W}$ To: Typical $R_{\theta JA} = 94^\circ\text{C/W}$ | 5 |
| • Changed Figure 11 - X axis values | 5 |
| Changes from Revision B (January 2010) to Revision C | Page |
| • Changed the labels on the Bottom View pinout image | 1 |
| Changes from Revision C (February 2010) to Revision D | Page |
| • Deleted the Package Marking Information section | 7 |

IMPORTANT NOTICE AND DISCLAIMER

TI PROVIDES TECHNICAL AND RELIABILITY DATA (INCLUDING DATASHEETS), DESIGN RESOURCES (INCLUDING REFERENCE DESIGNS), APPLICATION OR OTHER DESIGN ADVICE, WEB TOOLS, SAFETY INFORMATION, AND OTHER RESOURCES "AS IS" AND WITH ALL FAULTS, AND DISCLAIMS ALL WARRANTIES, EXPRESS AND IMPLIED, INCLUDING WITHOUT LIMITATION ANY IMPLIED WARRANTIES OF MERCHANTABILITY, FITNESS FOR A PARTICULAR PURPOSE OR NON-INFRINGEMENT OF THIRD PARTY INTELLECTUAL PROPERTY RIGHTS.

These resources are intended for skilled developers designing with TI products. You are solely responsible for (1) selecting the appropriate TI products for your application, (2) designing, validating and testing your application, and (3) ensuring your application meets applicable standards, and any other safety, security, or other requirements. These resources are subject to change without notice. TI grants you permission to use these resources only for development of an application that uses the TI products described in the resource. Other reproduction and display of these resources is prohibited. No license is granted to any other TI intellectual property right or to any third party intellectual property right. TI disclaims responsibility for, and you will fully indemnify TI and its representatives against, any claims, damages, costs, losses, and liabilities arising out of your use of these resources.

TI's products are provided subject to TI's Terms of Sale (www.ti.com/legal/termsofsale.html) or other applicable terms available either on ti.com or provided in conjunction with such TI products. TI's provision of these resources does not expand or otherwise alter TI's applicable warranties or warranty disclaimers for TI products.

Mailing Address: Texas Instruments, Post Office Box 655303, Dallas, Texas 75265
Copyright © 2018, Texas Instruments Incorporated

Looking for pricing, stock, or lifecycle information?

Click below to explore more details on WIN SOURCE:

 [View CSD16407Q5C on WIN SOURCE](#)

 [Texas Instruments](#) Information

Optimize Your Supply Chain with WIN SOURCE Solutions

-  Global Sourcing Solution
-  Obsolete Management
-  Cost Control Management
-  Shortage Management
-  Alternative Solution
-  Excess Inventory Management