



**THE DATASHEET OF  
SD1224**



**SD1224**

**RF AND MICROWAVE TRANSISTORS  
VHF FM APPLICATIONS**

**Features**

- 175 MHz
- 28 VOLTS
- CLASS C
- COMMON EMITTER
- EFFICIENCY 60% MIN.
- P<sub>OUT</sub> = 40 W MIN.
- G<sub>P</sub> = 7.6 dB GAIN

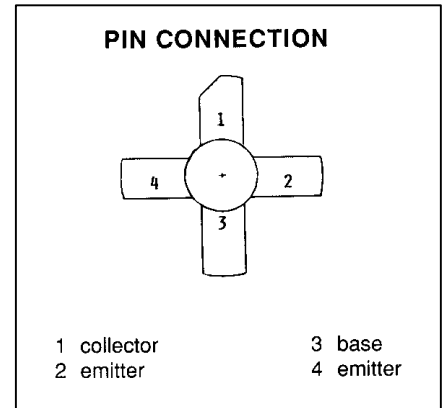
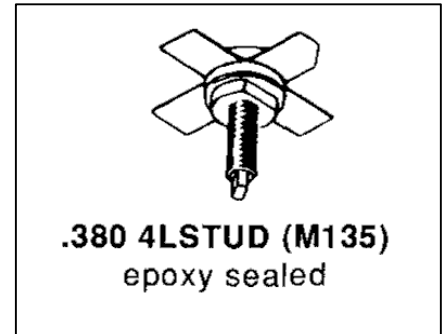

**DESCRIPTION:**

The SD1224 is an epitaxial silicon NPN planar transistor designed primarily for 28 V FM Class C RF amplifiers utilized in ground station transmitters. This device utilizes ballasted emitter resistors and improved metallization systems to achieve optimum load mismatch capability.

**ABSOLUTE MAXIMUM RATINGS (T<sub>case</sub> = 25°C)**

Symbol	Parameter	Value	Unit
V <sub>CBO</sub>	Collector-Base Voltage	65	V
V <sub>CEO</sub>	Collector-Emitter Voltage	35	V
V <sub>EBO</sub>	Emitter-Base Voltage	4.0	V
I <sub>C</sub>	Device Current	5.0	A
P <sub>DISS</sub>	Power Dissipation	60	W
T <sub>J</sub>	Junction Temperature	+200	°C
T <sub>STG</sub>	Storage Temperature	-65 to +150	°C

**THERMAL DATA**

R <sub>TH(j-c)</sub>	Junction-Case Thermal Resistance	2.9	°C/W
----------------------	----------------------------------	-----	------

**ELECTRICAL SPECIFICATIONS (T<sub>case</sub> = 25°C)**
**STATIC**

Symbol	Test Conditions	Value			Units
		Min.	Typ.	Max.	
<b>BV<sub>CBO</sub></b>	<b>I<sub>C</sub> = 10 mA    I<sub>B</sub> = 0 mA</b>	<b>65</b>			<b>V</b>
<b>BV<sub>CES</sub></b>	<b>I<sub>C</sub> = 200 mA    V<sub>BE</sub> = 0 V</b>	<b>65</b>		—	<b>V</b>
<b>BV<sub>CEO</sub></b>	<b>I<sub>C</sub> = 200 mA    I<sub>B</sub> = 0 mA</b>	<b>35</b>			<b>V</b>
<b>BV<sub>EBO</sub></b>	<b>I<sub>E</sub> = 10 mA    I<sub>C</sub> = 0 mA</b>	<b>4.0</b>			<b>V</b>
<b>I<sub>CES</sub></b>	<b>V<sub>CE</sub> = 30 V    I<sub>E</sub> = 0 mA</b>			<b>10</b>	<b>mA</b>
<b>I<sub>CBO</sub></b>	<b>V<sub>CB</sub> = 30 V    I<sub>E</sub> = 0 mA</b>			<b>1</b>	<b>mA</b>
<b>h<sub>FE</sub></b>	<b>V<sub>CE</sub> = 5 V    I<sub>C</sub> = 500 mA</b>	<b>5</b>		<b>200</b>	—

**DYNAMIC**

Symbol	Test Conditions	Value			Units
		Min.	Typ.	Max.	
<b>P<sub>OUT</sub></b>	<b>f = 175 MHz    P<sub>IN</sub> = 7.0 W    V<sub>CE</sub> = 28 V</b>	<b>40</b>			<b>W</b>
<b>G<sub>P</sub></b>	<b>f = 175 MHz    P<sub>IN</sub> = 7.0 W    V<sub>CE</sub> = 28 V</b>	<b>7.6</b>			<b>dB</b>
<b>η<sub>C</sub></b>	<b>f = 175 MHz    P<sub>IN</sub> = 7.0 W    V<sub>CE</sub> = 28 V</b>	<b>60</b>			<b>%</b>
<b>C<sub>OB</sub></b>	<b>f = 1 MHz    V<sub>CB</sub> = 30 V</b>			<b>65</b>	<b>pF</b>

**IMPEDANCE DATA**

<b>P<sub>IN</sub> (W)</b>	<b>P<sub>OUT</sub> (W)</b>	<b>Z<sub>IN</sub> (Ω)</b>	<b>Z<sub>CL</sub> (Ω)</b>
<b>2.0</b>	<b>28.5</b>	<b>0.85 + j 1.20</b>	<b>3.25 + j 7.05</b>
<b>4.0</b>	<b>43.0</b>	<b>1.02 + j 1.32</b>	<b>4.45 + j 5.40</b>
<b>6.0</b>	<b>53.0</b>	<b>1.01 + j 1.42</b>	<b>5.25 + j 4.42</b>
<b>8.0</b>	<b>60.5</b>	<b>1.05 + j 1.35</b>	<b>5.45 + j 4.12</b>

**Test Conditions:**    **V<sub>CE</sub> = 28 V**  
                                  **f = 175 MHz**

PACKAGE MECHANICAL DATA

PACKAGE STYLE M135

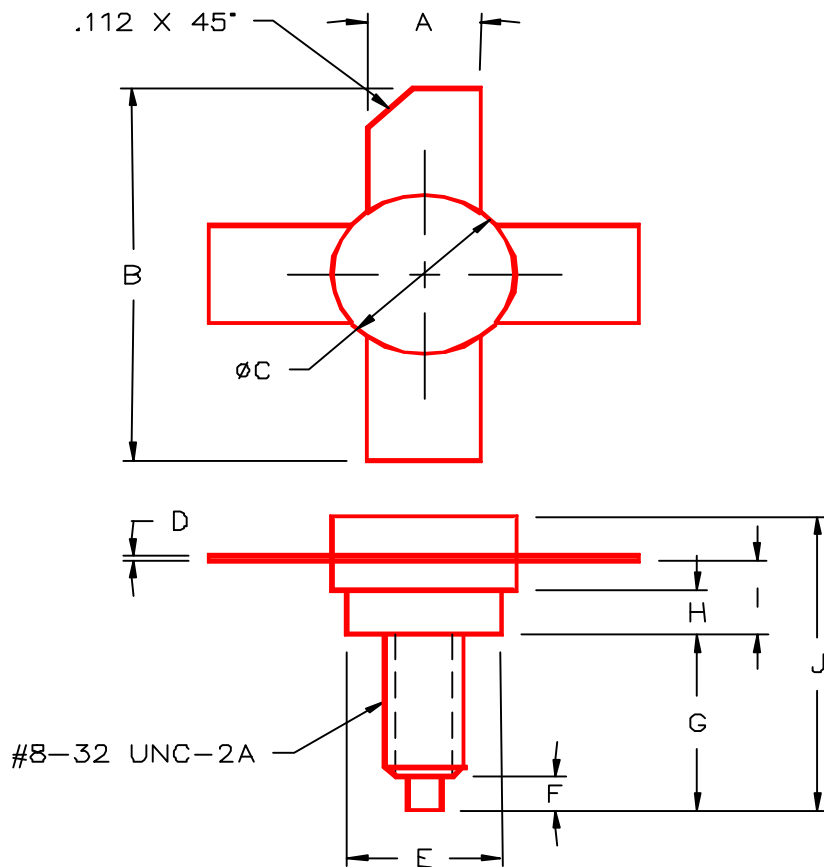

	MINIMUM INCHES/MM	MAXIMUM INCHES/MM		MINIMUM INCHES/MM	MAXIMUM INCHES/MM
A	.220/5,59	.230/5,84	I	.155/3,94	.175/4,45
B	.980/24,89		J		.750/19,05
C	.370/9,40	.385/9,78			
D	.004/0,10	.007/0,18			
E	.320/8,13	.330/8,38			
F	.100/2,54	.130/3,30			
G	.450/11,43	.490/12,45			
H	.090/2,29	.100/2,54			

## Looking for pricing, stock, or lifecycle information?

Click below to explore more details on WIN SOURCE:

- ⊖ [View SD1224 on WIN SOURCE](#)
- ⊖ [Microsemi Corporation](#) Information

## Optimize Your Supply Chain with WIN SOURCE Solutions

- ✓ Global Sourcing Solution
- ✓ Obsolete Management
- ✓ Cost Control Management
- ✓ Shortage Management
- ✓ Alternative Solution
- ✓ Excess Inventory Management