



**THE DATASHEET OF  
SIP-ASRNXS001**





SAMSUNG  
**ARTIK**<sup>™</sup> Modules

**7**

**710 Datasheet**



ARTIK 710 Module Top View

Samsung’s ARTIK™ 710 Module is a highly-integrated System-in-Module that utilizes an octa-core ARM® Cortex®-A53 processor packaged DRAM and Flash memory, a hardware Secure Element and a wide range of wireless communication options such as 802.11a/b/g/n/ac, Bluetooth® 4.1 (Classic+BLE), and 802.15.4 (ZigBee® or Thread) communications all into an extremely compact footprint. The many standard digital control interfaces support external sensors and higher performance peripherals to expand the module’s capabilities. With the combination of Wi-Fi, Bluetooth, ZigBee/Thread, the ARTIK 710 Module is the perfect choice for home automation and home hub devices, while also supporting a rich UI/UX capability with the camera and display support options. The hardware based Secure Element works with the ARM® TrustZone® and Trustware’s Trusted Execution Environment (TEE) to provide enhanced end-to-end security.

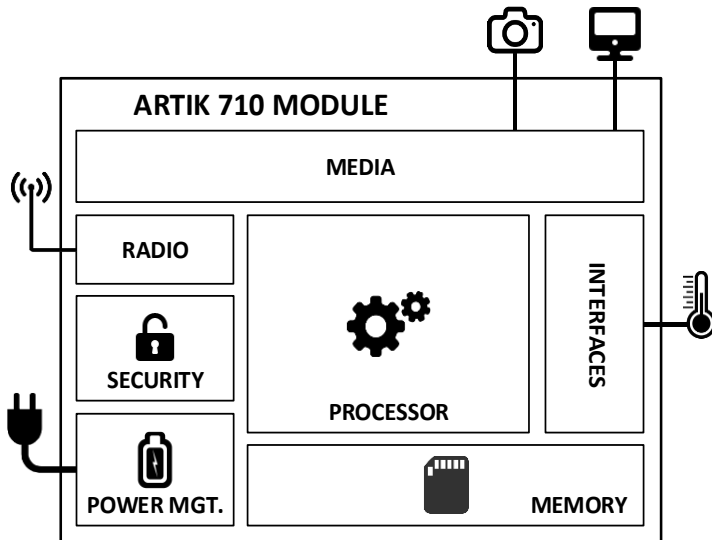

ARTIK 710 Module Block Diagram

Processor	
CPU	8x ARM® Cortex®-A53@1.4GHz
GPU	3D graphics accelerator
Media	
Camera I/F	4-Lane MIPI CSI
Display	4-Lane MIPI DSI up to FHD@24bpp
Audio	I <sup>2</sup> S audio interface
Memory	
DRAM	1GB DDR3 @ 800MHz
FLASH	4GB eMMC
Security	
Secure Element	Secure point to point authentication and data transfer
Trusted Execution Environment	Trustware
Radio	
WLAN	IEEE 802.11a/b/g/n/ac
Bluetooth	4.1 (Classic+BLE)
802.15.4	ZigBee/Thread
Power Management	
PMIC	Provides all power of the ARTIK 710 Module using on board bucks and LDOs
Interfaces	
Analog and Digital I/O	GPIO, I <sup>2</sup> C, SPI, UART, SDIO, USB 2.0, JTAG, Analog Input

SAMSUNG ELECTRONICS RESERVES THE RIGHT TO CHANGE PRODUCTS, INFORMATION AND SPECIFICATIONS WITHOUT NOTICE. Products and specifications discussed herein are for reference purposes only. All information discussed herein is provided on an "AS IS" basis, without warranties of any kind. This document and all information discussed herein remain the sole and exclusive property of Samsung Electronics. No license of any patent, copyright, mask work, trademark or any other intellectual property right is granted by one party to the other party under this document, by implication, estoppel or other-wise. Samsung products are not intended for use in life support, critical care, medical, safety equipment, or similar applications where product failure could result in loss of life or personal or physical harm, or any military or defense application, or any governmental procurement to which special terms or provisions may apply. For updates or additional information about Samsung products, contact your nearest Samsung office. All brand names, trademarks and registered trademarks belong to their respective owners.

# TABLE OF CONTENTS

Table of Contents .....	3
List of Figures .....	5
List of Tables .....	5
<i>Version History</i> .....	7
ARTIK 710 Module Block Diagram and Component Placement .....	8
<i>ARTIK 710 Module ZigBee or Thread</i> .....	10
<i>ARTIK 710 Module 802.15.4 Front End</i> .....	10
<i>ARTIK 710 Module Memory</i> .....	10
<i>ARTIK 710 Module PMIC</i> .....	10
<i>ARTIK 710 Module Wi-Fi/Bluetooth</i> .....	11
<i>ARTIK 710 Module Secure Element</i> .....	11
<i>ARTIK 710 Module Secure JTAG</i> .....	12
<i>ARTIK 710 Module Processor System</i> .....	12
ARTIK 710 Module PADS .....	21
ARTIK 710 Module Functional Interfaces .....	29
ADC .....	29
Booting .....	29
Bluetooth PCM .....	29
MIPI CSI .....	29
MIPI DSI .....	30
GMAC .....	30
GPIO .....	30
HDMI .....	31
HSIC .....	31
I <sup>2</sup> C .....	31
I <sup>2</sup> S .....	32
JTAG .....	32
Key .....	32
LVDS .....	32
Miscellaneous .....	33
Power .....	33
PWM .....	34
SD/MMC .....	34
SPI .....	34
UART .....	35
USB HOST/USB OTG .....	35
ZIGBEE .....	35
ARTIK 710 Module GPIO Alternate Functions .....	36
ARTIK 710 Module Booting Sequence .....	40
ARTIK 710 Module Power States .....	41
ARTIK 710 Module Antenna Connections .....	42
ARTIK 710 Module Electrical Specifications .....	43
<i>Absolute Maximum Ratings</i> .....	43
<i>Recommended Operating Conditions</i> .....	43
<i>DC Module Use Case Characteristics</i> .....	44
<i>Power Supply Requirements</i> .....	44
<i>ESD Ratings</i> .....	49
<i>DC Electrical Characteristics</i> .....	50
<i>AC Electrical Characteristics</i> .....	52
<i>RF Electrical Characteristics</i> .....	57
ARTIK 710 Module Mechanical Specifications .....	64

Ordering Information ..... 66  
Legal Information ..... 67

## LIST OF FIGURES

Figure 1. ARTIK 710 Module Functional Block Diagram .....	8
Figure 2. ARTIK 710 Module Component Placement - Top View .....	9
Figure 3. Front and Back of the certified ARTIK 710 Module .....	9
Figure 4. Processor System Block Schematic .....	13
Figure 5. ARTIK 710 Module Top View BALL Organization .....	21
Figure 6. ARTIK 710 Module Power Management State Diagram .....	41
Figure 7. RF Connector for BT/Wi-Fi and ZigBee/Thread .....	42
Figure 8. ARTIK 710 Module Power Distribution .....	44
Figure 9. High Speed SDMMC Interface Timing .....	52
Figure 10. SPI Interface Timing (CPHA = 0, CPOL = 1 (Format A)) .....	53
Figure 11. I <sup>2</sup> C Interface Timing .....	56
Figure 12. ARTIK 710 Module Mechanical Dimensions .....	64
Figure 13. Mechanical Bottom View and Top View .....	64
Figure 14. L-Shaped PAD Pins .....	65

## LIST OF TABLES

Table 1. TOP BALL ARRAY .....	22
Table 2. BOTTOM BALL ARRAY .....	24
Table 3. LEFT BALL ARRAY .....	26
Table 4. RIGHT BALL ARRAY .....	27
Table 5. ADC .....	29
Table 6. Booting .....	29
Table 7. Bluetooth PCM .....	29
Table 8. MIPI CSI .....	29
Table 9. MIPI DSI .....	30
Table 10. GMAC .....	30
Table 11. GPIO .....	30
Table 12. HDMI .....	31
Table 13. HSIC .....	31
Table 14. I <sup>2</sup> C .....	31
Table 15. I <sup>2</sup> S .....	32
Table 16. JTAG .....	32
Table 17. Key .....	32
Table 18. LVDS .....	32
Table 19. Miscellaneous .....	33
Table 20. Power .....	33
Table 21. PWM .....	34
Table 22. SD/MMC .....	34
Table 23. SPI .....	34

Table 24. UART.....	35
Table 25. USB Host/USB OTG .....	35
Table 26. ZigBee .....	35
Table 27. GPIO Alternate Functions TOP PART .....	36
Table 28. GPIO Alternate Functions BOTTOM PART .....	37
Table 29. GPIO Alternate Functions LEFT PART .....	39
Table 30. GPIO Alternate Functions RIGHT PART .....	39
Table 31. Booting Scenarios .....	40
Table 32. Booting Options.....	40
Table 33. Absolute Maximum Ratings.....	43
Table 34. Recommended Operating Conditions.....	43
Table 35. DC-DC Converter Description .....	44
Table 36. PMIC LDOs.....	45
Table 37. AC/DC Characteristics LDO1, LDO2, LDO4.....	46
Table 38. AC/DC Characteristics LDO1, LDO2, LDO4 Eco Mode .....	46
Table 39. AC/DC Characteristics LDO5 .....	47
Table 40. AC/DC Characteristics LDO5 Eco Mode .....	47
Table 41. AC/DC Characteristics LDO7, LDO8, LDO9, LDO10.....	48
Table 42. ESD Ratings .....	49
Table 43. Shock and Vibration Ratings .....	49
Table 44. I/O DC Electrical Characteristics GPIO .....	50
Table 45. I/O DC Electrical Characteristics GPIO .....	50
Table 46. I/O DC Electrical Characteristics PMIC .....	51
Table 47. I/O DC Electrical Characteristics GPIO .....	51
Table 48. GPIO Pull-up Resistor Current .....	51
Table 49. Power on Reset Timing Specifications.....	51
Table 50. High Speed SDMMC Interface Transmit/Receive Timing Constants .....	52
Table 51. SPI Interface Transmit/ Receive Timing Constants with 15pF Load .....	54
Table 52. SPI Interface Transmit/ Receive Timing Constants with 30pF Load .....	55
Table 53. I <sup>2</sup> C BUS Controller Module Signal Timing.....	56
Table 54. Wi-Fi WLAN 2.4GHz Receiver RF Specifications .....	57
Table 55. Wi-Fi WLAN 2.4GHz Transmitter RF Specifications .....	58
Table 56. Wi-Fi WLAN 5GHz Receiver RF Specifications .....	58
Table 57. Wi-Fi WLAN 5GHz Transmitter RF Specifications .....	60
Table 58. Bluetooth Receiver RF Specifications .....	61
Table 59. Bluetooth Transmitter RF Specifications.....	61
Table 60. BLE RF Specifications .....	61
Table 61. 802.15.4 RF Receive Specifications .....	62
Table 62. ZigBee/Thread RF Transmit Specifications .....	63
Table 63. ZigBee/Thread RF Receive Specifications.....	63
Table 64. L-Shaped Ball Locations .....	65



# ARTIK 710 MODULE BLOCK DIAGRAM AND COMPONENT PLACEMENT

Figure 1 shows the functional block diagram of the ARTIK 710 Module. It consists of an octa-core ARM® Cortex®-A53 application processor with 1GB of DDR3 and 4GB eMMC Flash, PMIC power management SoC, Secure Element, Wi-Fi/BT chipset, ZigBee/Thread chipset and RF connectors.

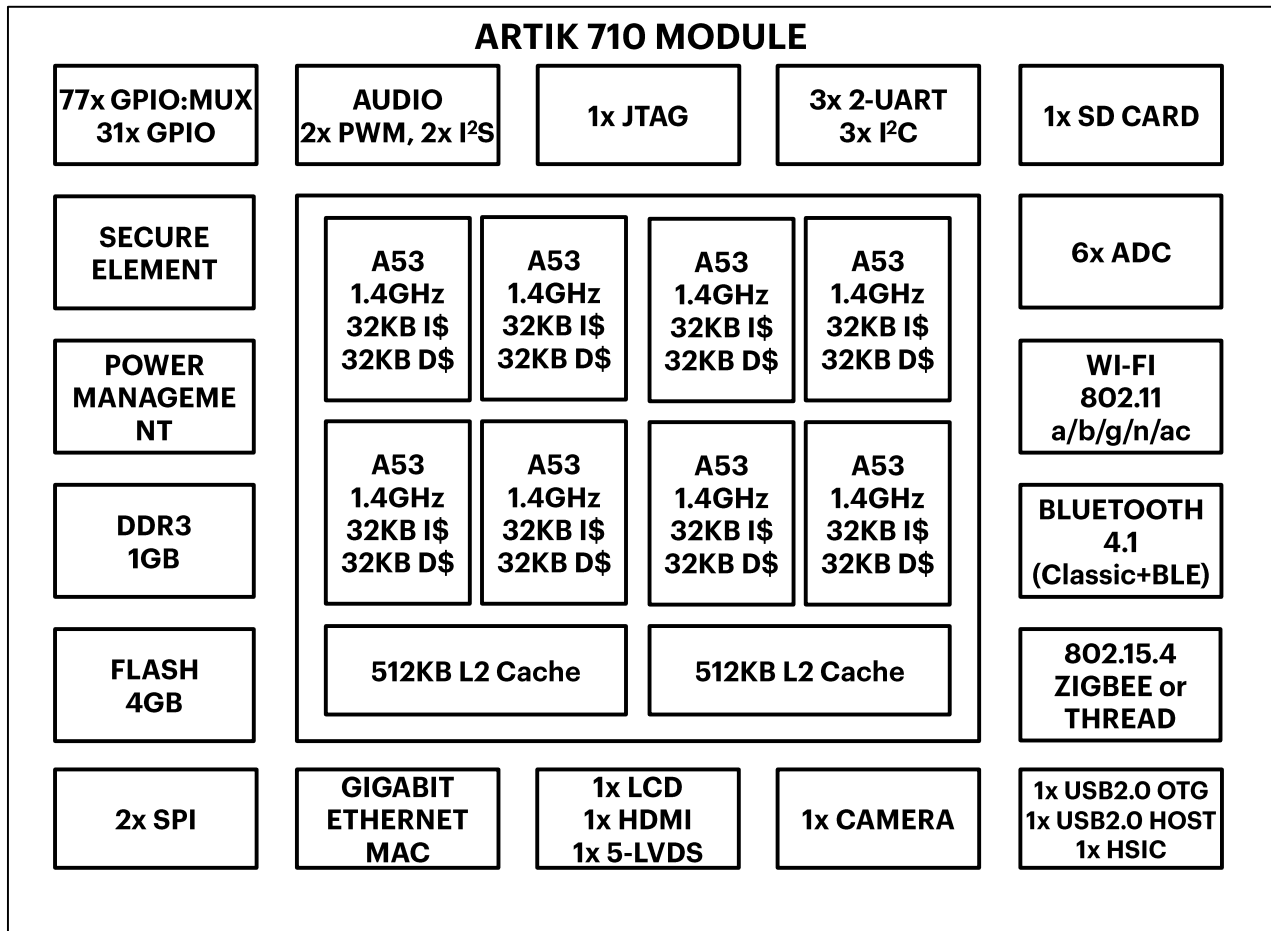

Figure 1. ARTIK 710 Module Functional Block Diagram

Figure 2 shows the Top View with component placement of the ARTIK 710 Module. The top side of the ARTIK 710 Module is populated with the octa-core ARM® A53 application processor, 2x 512MB of DDR3 memory chips, PMIC power manager, Wi-Fi/BT combo chipset, 4GB of Flash, 802.15.4 chipset to support ZigBee or Thread, PA and RF connectors for Wi-Fi/BT and 802.15.4 antennas. In addition Figure 3 shows the front and back of the certified ARTIK 710 Module.

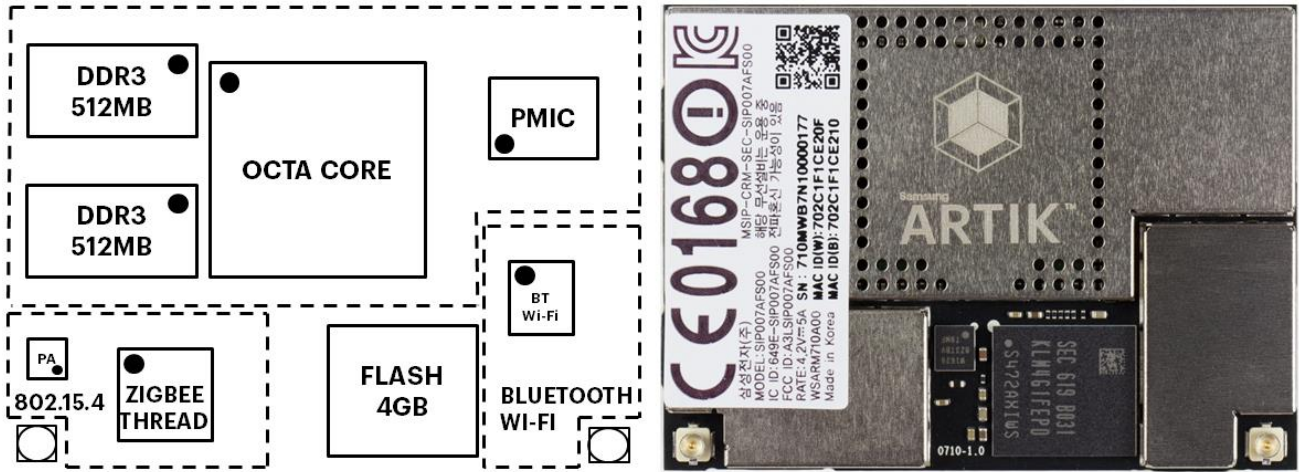

Figure 2. ARTIK 710 Module Component Placement - Top View

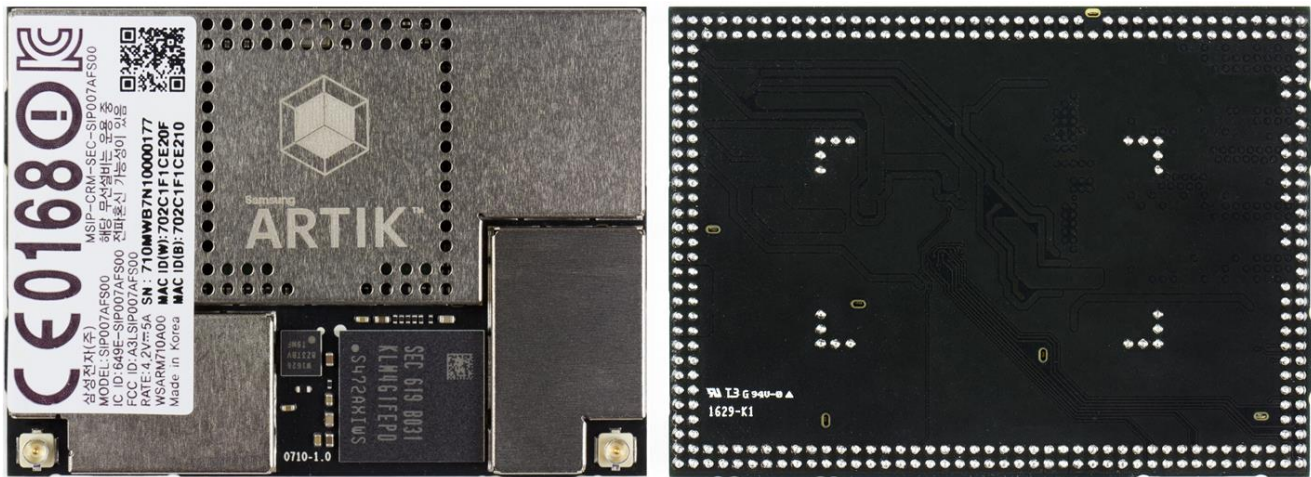

Figure 3. Front and Back of the certified ARTIK 710 Module

## ARTIK 710 MODULE ZIGBEE OR THREAD

The ARTIK 710 Module carries a fully-integrated 802.15.4 device. It integrates a 2.4 GHz, IEEE 802.15.4-2003-compliant transceiver, 32-bit ARM<sup>®</sup> Cortex<sup>®</sup>-M3 microprocessor, flash and RAM memory and peripherals. The most important hardware features of the ZigBee or Thread module are:

- Complete system-on-chip using 32-bit ARM<sup>®</sup> Cortex<sup>®</sup>-M3 processor.
- Single-voltage operation

## ARTIK 710 MODULE 802.15.4 FRONT END

The ARTIK 710 Module carries a fully integrated RF Front-End Module (FEM) designed specifically for low power sensitive IoT environments. The most important hardware features of the front-end are:

- Combined Tx/Rx transceiver port and single antenna port
- 2.4GHz high power amplifier with low pass harmonic filter
- Low noise amplifier
- Transmit/Receive switch
- Integrated power detector monitoring and controlling transmit power
- CMOS control logic
- 50Ω input output matching

## ARTIK 710 MODULE MEMORY

The ARTIK 710 Module has 2x 512MB DDR3 memory chips running at 800MHz each. In addition the ARTIK 710 module has 1x 4GB eMMC Flash memory chip based on the JEDEC MMC 4.51/5.0 standard. The interface speed varies from 200MB/s using MMC4.51 to 400MB/s when using the MMC5.0 standard.

## ARTIK 710 MODULE PMIC

The ARTIK 710 Module has a fully-integrated PMIC containing 5 High efficiency DC-DC converters and 10 LDOs. This unit provides all power requirements for the ARTIK 710 Module in one compact form factor. In addition, various stable power outputs are offered at the connectors, such that additional customer-defined use cases can be defined and efficiently implemented.

## ARTIK 710 MODULE WI-FI/BLUETOOTH

The ARTIK 710 Module has a fully-integrated IEEE 802.11 a/b/g/n/ac MAC baseband radio, Bluetooth 4.1 and an FM receiver. The most important hardware features of the Wireless LAN/Bluetooth combo SoC are:

- IEEE802.11 Features
  - WLAN 802.11 ac compliant:
    - Single-stream spatial multiplexing up to 433Mbps
    - Support for 20, 40 and 80 MHz channels including 256 QAM
  - Supports explicit 802.11ac transmit beamforming
  - On chip PA for both bands
- Bluetooth Features
  - Support v4.1 with provisions to support future specifications
  - Bluetooth Class 1 or Class 2 transmitter operation
  - Support for Adaptive Frequency Hopping (reduce interference)
    - Using a 4-wire UART interface

## ARTIK 710 MODULE SECURE ELEMENT

The ARTIK 710 Module has a dedicated Secure Element to assure end-to-end authentication and communication between nodes in an IoT setting. The Secure Element provides an ISO/IEC 7816 14443 compliant interface. The most important hardware features of the Secure Element are:

- Dedicated 16-bit SecuCalm CPU core
- Crypto co-processor
  - Modular exponential accelerator
  - RSA 2080bits
  - ECC 512 bits
- Data security
  - Memory encryption for all memory
  - 256B read only and 256B non erasable flash area
  - Selective reset operation if abnormal voltages/frequencies are detected
- Embedded tamper-free memory
  - 32KB ROM
  - 264KB FLASH
  - 8.5KB Static RAM including 2.5KB crypto memory
- Serial interfaces:
  - ISO 7816-3 compliant interface
  - Asynchronous half-duplex character receive/transmit serial interface

## ARTIK 710 MODULE SECURE JTAG

Our secure JTAG core that is part of the ARTIK 710 Module provides debug capabilities for the developer. The secure JTAG core has an authentication, authorization and an access provider module to assure that only authorized developers have access to the hardware. The main features of the secure JTAG core are:

- Dedicated authentication process through password mechanism
- Dedicated Hash engine with hash sequencer
- Industry standard JTAG capabilities

## ARTIK 710 MODULE PROCESSOR SYSTEM

The processor system architecture that resides on the ARTIK 710 Module is a system-on-a-chip (SoC) based on a dual 32/64-bit RISC architecture. Designed using the 28nm low power process, the processor system architecture provides superior performance using an octa-core CORTEX<sup>®</sup>-A53 CPU. The ARTIK 710 Module contains 3D graphics hardware, image signal-processor hardware and a variety of high-speed interfaces such as eMMC5.0.

The ARTIK 710 Module allows for heavy traffic operations with a bandwidth up to 7.4GB/s such as 1080p video encoding and decoding, 3D graphics display and high resolution image signal processing with full HD display.

The application processor supports dynamic virtual-address mapping aiding software engineers to fully utilize the memory resources. The ARTIK 710 Module provides 3D graphics performance with a wide range of APIs such as OpenGL<sup>®</sup> ES1.1 and 2.0. The key features of the ARTIK 710 Module are:

- Octa-core ARM<sup>®</sup> Cortex<sup>®</sup>-A53 with 32KB I\$/32KB D\$ per core and shared 2x 512KB (per 4x cores) L2 Cache
- Memory subsystem:
  - DDR3 up to 800MHz
  - MLC/SLC NAND Flash support with hardwired ECC
- Supports 2D and 3D graphics hardware with OpenGL ES 1.1 and 2.0 software API
- Supports dual display up to 1920x1080 with TFT-LCD, LVDS, HDMI 1.4a and MIPI-DSI output
- Supports 10/100/1000M Ethernet MAC
- Supports a wide variety of interfaces such as S/PDIF, SPI, I<sup>2</sup>S, I<sup>2</sup>C, UART, USB, GPIOs, GMAC, PWM
- Supports up to 6 channels of ADC
- Supports MPEG-TS HW Parser
- Supports 1x USB Host, 1x USB OTG and 1x HSIC Host
- Supports secure JTAG
- Supports ARM TrustZone Technology
- Supports a variety of Power Modes (Normal, Sleep, Stop Modes)
- Supports a variety of Booting Options

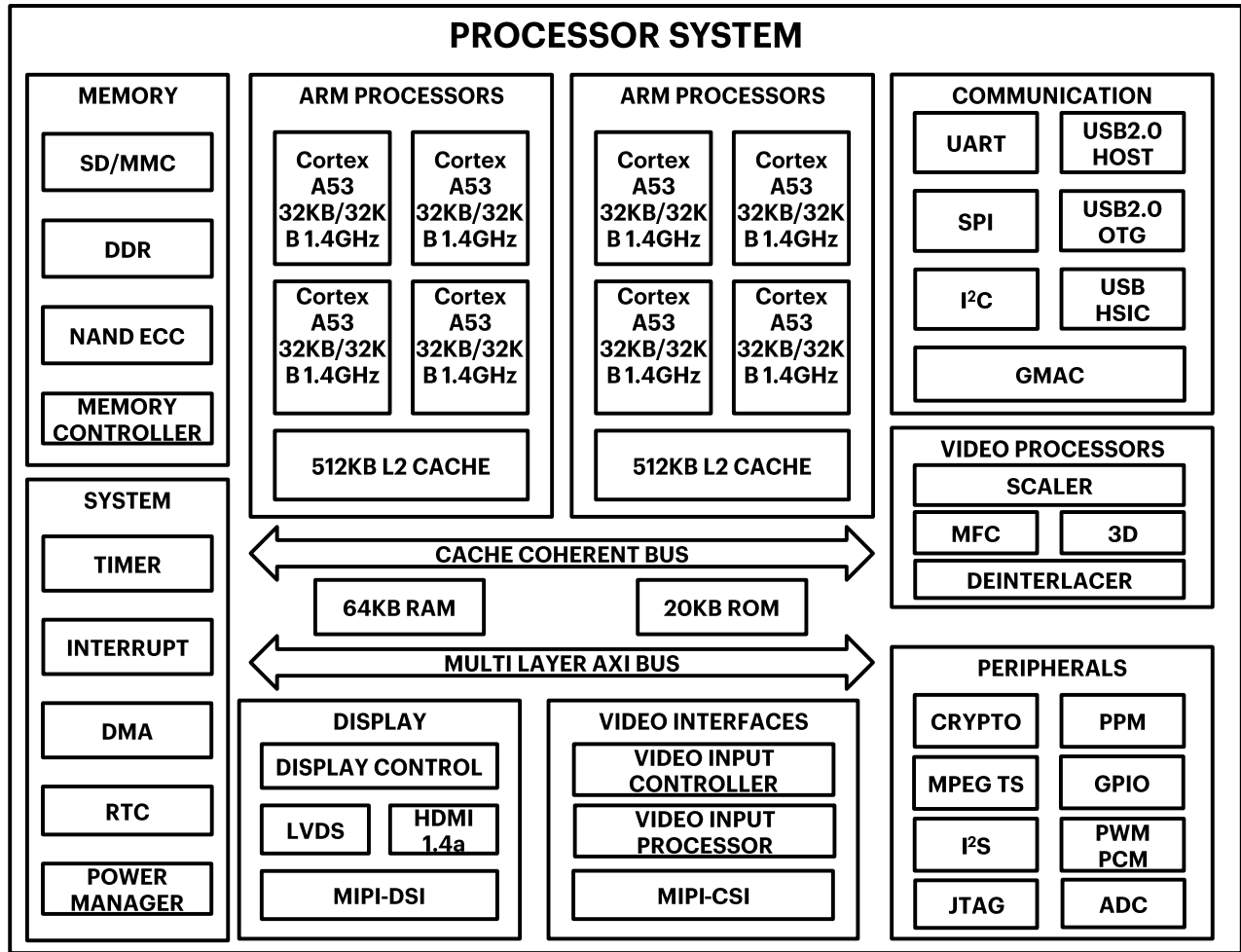

Figure 4. Processor System Block Schematic

**SD/MMC**

The ARTIK 710 Module provides 1x SD/MMC interface. The Mobile Storage Host is an interface between the system and SD/MMC card. The key features of mobile storage host sub-system are:

- Support for Secure Digital I/O (SDIO – version 3.0)
- Support for Secure Digital Memory (SDMEM – version 3.0)
- Consumer Electronics Advanced Transport Architecture (CE-ATA-version 1.1)
- Support for Embedded Multimedia Cards (MMC – version 4.41)
- Support for Embedded Multimedia Cards (eMMC – version 4.5)
- Support 8-bit DDR mode up to 50MHz
- Supports PIO and DMA mode data transfer
- Supports ¼- bit data bus width

**MEMORY CONTROLLER**

The most important features of the Memory module are:

- System Memory Controller
  - Support for 1GB DDR3 SDRAM
  - Maximum operating frequency of 800MHz
  - 32-bit data bus
- Static Memory Controller

- Multiplexed address up to 24-bit
- Support for SRAM, ROM and NAND flash
- Support for burst read/write
- NAND Flash Controller
  - Support for SLC/MLC Nand flash
  - ECC algorithm support

#### TIMER/WATCHDOG TIMER

The most important features of the Timer/Watchdog module are:

- 4x dedicated Timer channels with watchdog timer
- Normal interval timer mode with interrupt request
- Reset on timer countdown
- Level-triggered interrupt mechanism

#### INTERRUPT CONTROLLER

The most important features of the Interrupt Controller module are:

- Vectored Interrupt Controller
- Support for 4x interrupt types
  - 16x software generated interrupts
  - 6x External Private Peripheral Interrupt (PPI) per processor
  - 1x Internal PPI for each processor
  - 128x Shared peripheral interrupts
- For each interrupt source the following properties are available:
  - Fixed hardware interrupt priority level
  - Programmable interrupt priority level
  - Hardware interrupt priority level masking
  - IRQ and FIQ generation
  - Software interrupt generation
  - Test registers
  - Raw interrupt status
  - Interrupt request status

#### DMA

The most important features of the Scatter-Gather DMA module are:

- 16x channels of dedicated DMA
- 16x DMA request lines
- Various operating modes
  - Single DMA mode
  - Burst DMA mode
  - Memory 2 memory transfer
  - Memory to peripheral transfer
  - Peripheral to memory transfer
- Support for 8/16/32 bit wide transactions
- Big-Endian and Little-Endian (default) support

#### REAL TIME CLOCK (RTC) & POWER MANAGER

The most important features of the RTC and Power Manager module are:

- 4x spread spectrum PLLs
- 2x external crystals : 1x 24MHz crystal for PLL, 1x 32.768KHz crystal for RTC
- 32-bit RTC counter
- Support for alarm interrupt using RTC
- Support for various power modes
  - Normal, Idle, Stop, Sleep (Suspend to RAM)

## ARM PROCESSORS

The most important features of the CPU module are:

- 8x Cortex A53 cores running at 1.4GHz
- Each core has 32KB of I-Cache (I\$) and 32KB of D-Cache (D\$)
- 2x 512KB of L2 Cache is shared between 2x4 cores
- Dedicated Vector Floating Point Processor (VFPP), Neon processor

## LVDS

The ARTIK 710 Module provides 5x LVDS output channels with 1x clock channel. The key features of the LVDS channel system are:

- Output clock range 30-160MHz
- Support for 630 Mbps per channel
- Up to 393.75MB/s data transport
- Support for power down mode

## MIPI DSI

The ARTIK 710 Module provides 1x 4-lane MIPI interface that complies with the MIPI DSI standard specification V1.01r11. The key features of the MIPI DSI sub-system are:

- Maximum resolution ranges up to WUXGA 1920x1200
- Supports 1, 2, 3 or 4 data lanes
- Supports pixel format:
  - 16bpp, 18bpp packed, 18bpp loosely-packed (3 byte), 24bpp
- Supported interfaces are:
  - Protocol-to-PHY Interface (PPI) up to 1.5Gbps, in MIPI D-PHY
  - RGB Interface for video image input from display controller
  - An I80 interface for Command Mode Image input from display controller
  - PMS control interface for PLL to configure byte clock frequency
  - Pre-scaler to generate escape clock from byte clock

## HDMI CONTROLLER

The ARTIK 710 Module provides 1x HDMI v1.4a interface. The key features of the HDMI sub-system are:

- Support for v1.4a spec
- Up to 1080p video resolution
- HDMI Link + HDMI PHY
- Support for the following video formats:
  - 480p@59.94/60Hz
  - 576p@50Hz
  - 720p@50/59.94/60Hz
  - 1080p@50/59.94/60Hz (No support for interlaced format)
- Support for 4:4:4 RGB
- Support for up to 8-bits per color
- HDMI-CEC compliant
- Integrated HDCP 1.4 compliant

## MIPI CSI

The ARTIK 710 Module provides 1x 4-lane MIPI interface that complies with the MIPI CSI standard specification V1.01r06 and D-PHY standard specification v1.0. The key features of the MIPI CSI sub-system are:

- Supports 1, 2, 3 or 4 data lanes
- Supported image formats are:
  - YUV420, YUV420 (Legacy), YUV420 (CSPS), 8-bit YUV422, 10-bit YUV422
  - RGB565, RGB666, RGB888

- RAW6, RAW7, RAW8, RAW10, RAW12, RAW14
- Compressed format : 10-6-10, 10-7-10, 10-8-10
- User defined Byte based data packet
- Compatible to PPI (Protocol to PHY interface)

## VIDEO INPUT PROCESSOR

The ARTIK 710 Module provides 1x Video Input Processor (VIP). The key features of the VIP sub-system are:

- Support for external 8-bit and 16-bit MIPI
- Support for internal MIPI CSI
- Support of images up to 8192x8192
- Support for clipping and scale-down
- Support for YUV420, YUV422 and YUV444 memory format and linear YUV422 memory format

## UART

The ARTIK 710 Module provides 3x2-pin UART with just RxD and TxD signals. The key features of the UART sub-system are:

- Separate 32x8 Tx and 32x12 Rx FIFO memory buffers
- Support for DMA and interrupt based mode of operation
- All independent channels support IrDA 1.0
- Support for modem control functions CTS, DCD, DSR, RTS, DTR and RI
- Each UART channel contains:
  - Programmable baud-rates
  - 1 or 2 stop bit insertion
  - 5-bit, 6-bit, 7-bit, or 8-bit data width
  - Parity checking

## SPI

The ARTIK 710 Module provides 2x Serial Peripheral Interfaces (SPI) that transfers serial data. SPI support includes 8-bit/16-bit shift registers to transmit and receive data. During an SPI transfer, data is simultaneously transmitted (shifted out serially) and received (shifted in serially). The SPI implementation adheres to the protocols described by Texas Instruments Synchronous Serial, National Semiconductor's Microwire and Motorola's Serial Peripheral Interface. The key features of the SPI sub-system are:

- Support for full-duplex
- 8-bit/16-bit shift register for Tx and Rx
- Complies with the SPI protocol described by Texas Instruments, National Semiconductor and Motorola
- Support for independent 16-bit wide transmit and receive FIFOs 8 locations deep
- Supports for master mode and slave mode
- Supports for receive-without-transmit operation
- Max operating frequency :
  - Master Mode : Support Tx up to 50MHz, Rx up to 20MHz
  - Slave Mode : Support Tx up to 8MHz, Rx up to 8MHz

## I<sup>2</sup>C

The ARTIK 710 Module provides 3x generic I<sup>2</sup>C blocks supporting both 100kb/s and 400kb/s speed modes. The key features of the I<sup>2</sup>C sub-system are:

- Supporting multi-master and slave mode
- 7-bit addressing mode only
- Supports serial, 8-bit oriented and bi-directional data transfer
- Supports up to 100 kb/s in the standard mode
- Supports up to 400 kb/s in the fast mode
- Supports master transmit, master receive, slave transmit, and slave receive operation
- Supports both interrupt and polling events

## USB OTG

The ARTIK 710 Module provides 1x USB2.0 OTG interface supporting both device and host functionality. The key features of the USB2.0 OTG sub-system are:

- In compliance with the USB 2.0 On-The-Go specification revision 1.3a
- Operates in High Speed (480Mbps) Mode
- Operates in Full Speed (12Mbps) Mode
- Operates in Low Speed (1.5Mbps, host only) Mode
- Supports Session Request Protocol (SRP) and Host Negotiation Protocol (HNP)
- 1 control endpoint 0 for control transfer
- Supports up to 15 device-programmable endpoints:
  - Programmable endpoint type: Bulk, Isochronous, Interrupt
  - Programmable In/Out direction
- Supports 16 host channels

## USB HOST/HSIC

The ARTIK 710 Module provides 1x USB2.0 Host controller that is fully compliant with the USB 2.0 specifications, and the Enhanced Host Controller Interface (EHCI) specification. The controller also provides a High Speed Inter Chip (HSIC) version 1.0 module. The key features of the USB2.0 OTG sub-system are:

- Detecting the attachment and removal of USB devices
- Collecting status and activity statistics
- Controlling power supply to attached USB devices
- In compliance with the UTMI+ Level3 revision 1.0
- Controlling the association to either the Open Host Controller Interface or the EHCI via a port router
- Root Hub functionality to support up/down stream port
- Support for HSIC version 1.0

## ETHERNET MAC CONTROLLER

The most important features of the Ethernet MAC module are:

- Standard compliance
  - IEEE 802.3az-2010 (Energy Efficient Ethernet EEE)
  - RGMII v2.6
- MAC supports the following features:
  - 10/100/1000 Mbps data transfer rates with an RGMII interface to communicate with external gigabit PHY
  - Full duplex operation
  - Half duplex operation
  - Flexible address filtering
  - Additional frame filtering

## SCALER

The ARTIK 710 Module provides a universal scaler. The key features of the scaler are:

- Support for different input formats
  - YUV420, YUV422, YUV444, interleaved UV
- Flexible size, from 8x8 up to 4096x4096 with a granularity of 8
- Upscale ratio from 8x8 to 4096x4096
- Downscale ratio from 4096x4096 to 8x8
- Low-pass filter available after upscale or before downscale
- Horizontal 5-tab filter with 64 sets of coefficients
- Vertical 3-tab filter with 32 sets of coefficients

## DE-INTERLACER

The ARTIK 710 Module provides a de-interlacer. The key features of the de-interlacer are:

- Support a maximum image width of 1920, image height is not limited

- Y, Cb and Cr are executed separately
- Separated YUV420, YUV422 and YUV444 format support

## MULTI FORMAT CODEC

The ARTIK 710 Module provides an integrated Multi Format Codec (MFC) module. The key features of the MFC sub-system are:

- Decoder
  - H.264 : BP, MP, HP Level 4.2 up to 1920x1080, up to 50MBps
  - MPEG4 : Advanced Simple Profile (ASP) up to 1920x1080, up to 40Mbps
  - H.263 : Profile 3 up to 1920x1080, up to 20Mbps
  - VC-1 : SP, MP, AP profile, Level 3 up to 1920x1080, Level 3 up to 2048x1024, up to 45Mbps
  - MPEG 1,2 : Main Profile, High Level up to 1920x1080, up to 80Mbps
  - VP8 : up to 1920x1080, up to 20Mbps
  - Theora : up to 1920x1080, up to 20Mbps
  - AVS : jizhun profile, Level 6.2 up to 1920x1080, up to 40Mbps
  - RV8/9/10 : up to 1920x1080, up to 40Mbps
  - MJPEG : Baseline profile up to 8192x8292
- Encoder
  - H.264 : Baseline profile, Level 4.0 up to 1080p, up to 20Mbps
  - MPEG4 : Simple profile, Level 5.6 up to 1080p, up to 20Mbps
  - H.263 : Profile 3, Level 70 up to 1080p, up to 20Mbps
  - MJPEG : Baseline profile up to 8192x8192

## GRAPHICS CONTROLLER

The ARTIK 710 Module provides 1x 2D and 1x 3D graphics accelerator. The key features of the graphics subsystem are:

- 2x pixel processors
  - Tile oriented processing
  - Alpha blending
  - Texture support, non-power-of-2
  - Cube mapping
  - Fast dynamic branching
  - Trigonometric acceleration
  - Full floating point arithmetic
  - Line, quad, triangle and point sprites
  - Perspective correct texturing
  - Point sampling, bilinear and trilinear filtering
  - 8-bit stencil buffering
  - 4-level hierarchical Z and stencil operation
- 1x geometry processor
  - Programmable vertex shader
  - Flexible input and output formats
  - Autonomous operation tile list generation
  - Indexed and non-indexed geometry input
  - Primitive constructions with points, lines, triangles and quads
- Support for OpenGL ES 1.0 and 2.0
- Support for OpenVG 1.1

## SECURITY IP

In addition to the Secure Element that is part of the ARTIK 710 Module, the main processor on the module provides additional security features:

- Secure 128-bit die ID
- On chip secure JTAG
  - Secure 128-bit JTAG ID
- On chip secure boot



- Secure 128-bit boot ID
- ARM TrustZone
  - TZPC (TrustZone Platform Controller)
  - TZASC (TrustZone Address Space Controller)
  - TZMA (TrustZone Memory Adapter)
- Hardware crypto accelerators
  - DES, Triple DES
  - AES
  - SHA-1
  - MD5
  - PRNG

### PPM PULSE PERIOD MEASUREMENT

The ARTIK 710 Module has a Pulse Period Measurement (PPM) IP-block that can measure the duration of a high level or low level from a GPIO pin. The PPM has a 16-bit counter that is tied to a clock that can vary between 843.750kHz-13.5MHz. For more details on how to relate a PPM to a GPIO please refer to the ARTIK 710 software developer's guide.

### MPEG TS

The ARTIK 710 Module provides 1x MPEG Transport Stream de-multiplexer. The most important features of the MPEG-TS are:

- Support for 8-bit parallel mode
- Support for internal and external DMA
- Support for encoding and decoding of AES and CAS based streams
- Support for 2x channel MPEG-TS input with simultaneous 1x channel MPEG-TS output

### I<sup>2</sup>S

The ARTIK 710 Module provides 2x 5-line Inter-IC Sound (I<sup>2</sup>S) channel. I<sup>2</sup>S is one of the most popular digital audio interfaces. The I<sup>2</sup>S bus handles audio data and other signals, such as sub-coding and control. It is possible to transmit data between two I<sup>2</sup>S buses. The key features of the I<sup>2</sup>S sub-system are:

- Supports 1-port stereo (1 channel) I<sup>2</sup>S-bus for audio with DMA based operation
- Supports serial data transfer of 16/24-bit per channel in Master and Slave mode
- Supports a variety of interface modes
  - I<sup>2</sup>S, Left justified, Right justified, DSP mode

### PCM

The ARTIK 710 Module provides 1x PCM channel. The PCM interface provides a bi-directional serial interface that can be connected to an external audio codec. The key features of the PCM sub-system are:

- Supports both Master and Slave mode external audio codecs
- Supports both short and long frame synchronization
- Supports a variety of data formats with a default format of 13-bit 2s complement, left justified, clock MSB first

### PWM

The ARTIK 710 Module provides 2x PWM instances. The key features of the PWM sub-system are:

- 2x individual PWM channels with independent duty control and polarity
- 2x 32-bit PWM timers, 1x per channel
- Support for static as well as dynamic setup
- Support for auto-reload and one-shot pulse mode
- Dead zone generator
- Level interrupt generation

### GPIO

The ARTIK 710 Module provides a GPIO system with up to 108 GPIOs (77 multiplexed, 31 dedicated) to allow for a wide variety of use cases to be supported. The key features of the GPIO system are:

- All GPIOs have programmable pull-up control
- All GPIOs have edge detect and level detect
- All GPIOs support programmable pull-up resistance
- All GPIOs can be set for Fast Slew or Normal Slew operation
- All GPIOs can be set for Default Drive Strength or High Drive Strength set by
- All GPIOs support individual interrupt generation and can be triggered on:
  - Rising edge
  - Falling edge
  - High level detection
  - Low level detection
- GPIO data is clocked in at 50MHz

## ADC

The ADC interface controls one 28nm low power CMOS 1.8V 12-bit ADC. The key features of the ADC sub-system are:

- Up to 6-channels of analog input can be selected
- Converts analog input into 12-bit binary code up to 1MSPS
- Power consumption 1.0mW when running 1MSPS
- Input frequency up to 100kHz

# ARTIK 710 MODULE PADS

The ARTIK 710 Module utilizes 271 signal and ground BALLS providing all the relevant signaling. *Figure 5* shows how the BALLS are oriented and how signal coordinates are assigned to the PADS of the ARTIK 710 Module. *Table 1, Table 2, Table 3* and *Table 4* describe the relation between the BALL coordinates and the BALL signal names. *Table 1, Table 2, Table 3* and *Table 4* also provide detailed characteristics for each BALL signal name.

PA1	PA2	PA3	PA4	PA5	PA6	PA7	PA8	PA9	PA10	PA11	PA12	PA13	PA14	No Ball	PA16	PA17	PA18	PA19	PA20	PA21	PA22	PA23	PA24	PA25	PA26	PA27	PA28	PA29	PA30	PA31	PA32	PA33	PA34	PA35	PA36	PA37	PA38	PA39	PA40	PA41	PA42	PA43	
PB1	PB2	PB3	PB4	PB5	PB6	PB7	PB8	PB9	PB10	PB11	PB12	PB13	PB14	PB15	PB16	PB17	PB18	PB19	PB20	PB21	PB22	PB23	PB24	PB25	PB26	PB27	PB28	PB29	PB30	PB31	PB32	PB33	PB34	PB35	PB36	PB37	PB38	PB39	PB40	PB41	PB42	PB43	
PC1	No Ball																																								PC42	PC43	
PD1	No Ball																																								PD42	PD43	
PE1	PE2																																								PE42	PE43	
PF1	PF2																																								PF42	PF43	
PG1	No Ball																																								PG42	PG43	
PH1	No Ball																																								PH42	PH43	
PI1	PI2											TP282	TP283	TP284											TP285	TP286	TP287											PI42	PI43				
PK1	PK2											TP301											TP288											PK42	PK43								
PL1	PL2											TP300											TP289											PL42	PL43								
PM1	PM2																																									PM42	PM43
PN1	PN2																																									PN42	PN43
PP1	No Ball																																								PP42	PP43	
PR1	PR2																																								PR42	PR43	
PT1	PT2																																								PT42	PT43	
PU1	No Ball																																								PU42	PU43	
PV1	No Ball																																								PV42	PV43	
PW1	PW2																																								PW42	PW43	
PY1	PY2																																								PY42	PY43	
PAA1	PAA2											TP299											TP290											PAA42	PAA43								
PAB1	PAB2											TP298											TP291											PAB42	PAB43								
PAC1	PAC2											TP297	TP296	TP295											TP294	TP293	TP292											PAC42	PAC43				
PAD1	PAD2																																									PAD42	PAD43
PAE1	PAE2																																								PAE42	PAE43	
PAF1	PAF2																																								PAF42	PAF43	
PAG1	PAG2																																								PAG42	PAG43	
PAH1	PAH2																																								PAH42	PAH43	
PAJ1	PAJ2																																								PAJ42	PAJ43	
PAK1	PAK2	PAK3	PAK4	PAK5	PAK6	PAK7	PAK8	PAK9	PAK10	PAK11	PAK12	PAK13	PAK14	PAK15	PAK16	PAK17	PAK18	PAK19	PAK20	PAK21	PAK22	PAK23	PAK24	PAK25	PAK26	PAK27	PAK28	PAK29	PAK30	PAK31	PAK32	PAK33	PAK34	PAK35	PAK36	PAK37	PAK38	PAK39	PAK40	PAK41	PAK42	PAK43	
PAL1	PAL2	PAL3	PAL4	PAL5	PAL6	PAL7	PAL8	PAL9	PAL10	PAL11	PAL12	PAL13	PAL14	PAL15	PAL16	PAL17	PAL18	PAL19	PAL20	PAL21	PAL22	PAL23	PAL24	PAL25	PAL26	PAL27	PAL28	PAL29	PAL30	PAL31	PAL32	PAL33	PAL34	PAL35	PAL36	PAL37	PAL38	PAL39	PAL40	PAL41	PAL42	PAL43	

Figure 5. ARTIK 710 Module Top View BALL Organization

## TOP BALL ARRAY

Table 1. TOP BALL ARRAY

BAL LOC	BALL Name	Power	Default	I/O Type	I/O	PU/PD	Group	Function
PA1	GMAC_TXEN	3V3	GMAC_TXEN	S	GPIO	N	GMAC	GMAC Transmit Enable
PA2	GMAC_TXD1	3V3	GMAC_TXD1	S	GPIO	N	GMAC	GMAC Transmit Data 1
PA3	GMAC_TXD3	3V3	GMAC_TXD3	S	GPIO	N	GMAC	GMAC Transmit Data 3
PA4	GND	0V0	GND	NA	0V0	-	GND	Ground
PA5	GMAC_GTXCLK	3V3	GMAC_GTXCLK	S	GPIO	N	GMAC	GMAC Transmit Clock
PA6	GMAC_RXDV	3V3	GMAC_RXDV	S	GPIO	N	GMAC	GMAC Receive Enable
PA7	GMAC_RXD2	3V3	GMAC_RXD2	S	GPIO	N	GMAC	GMAC Receive Data 2
PA8	GMAC_RXD0	3V3	GMAC_RXD0	S	GPIO	N	GMAC	GMAC Receive Data 0
PA9	GND	0V0	GND	NA	0V0	-	GND	Ground
PA10	AP_MIPICSI_DNCLK	1V8	MIPICSI_DNCLK	S	IO	N	CSI	MIPI CSI Data Negative Clock
PA11	AP_MIPICSI_DN0	1V8	MIPICSI_DN0	S	IO	N	CSI	MIPI CSI Data Negative 0
PA12	AP_MIPICSI_DN1	1V8	MIPICSI_DN1	S	IO	N	CSI	MIPI CSI Data Negative 1
PA13	AP_MIPICSI_DN2	1V8	MIPICSI_DN2	S	IO	N	CSI	MIPI CSI Data Negative 2
PA14	AP_MIPICSI_DN3	1V8	MIPICSI_DN3	S	IO	N	CSI	MIPI CSI Data Negative 3
PA15	NO BALL	-	-	-	-	-	NO BALL	NA
PA16	AP_MIPIDSI_DNCLK	1V8	MIPIDSI_DNCLK	S	IO	N	DSI	MIPI DSI Data Negative Clock
PA17	AP_MIPIDSI_DN0	1V8	MIPIDSI_DN0	S	IO	N	DSI	MIPI DSI Data Negative 0
PA18	AP_MIPIDSI_DN1	1V8	MIPIDSI_DN1	S	IO	N	DSI	MIPI DSI Data Negative 1
PA19	AP_MIPIDSI_DN2	1V8	MIPIDSI_DN2	S	IO	N	DSI	MIPI DSI Data Negative 2
PA20	AP_MIPIDSI_DN3	1V8	MIPIDSI_DN3	S	IO	N	DSI	MIPI DSI Data Negative 3
PA21	GND	0V0	GND	NA	0V0	-	GND	Ground
PA22	AP_LVDS_TN0	1V8	LVDS_TN0	S	IO	N	LVDS	LVDS Transmit Channel 0 Negative
PA23	AP_LVDS_TN1	1V8	LVDS_TN1	S	IO	N	LVDS	LVDS Transmit Channel 1 Negative
PA24	AP_LVDS_TN2	1V8	LVDS_TN2	S	IO	N	LVDS	LVDS Transmit Channel 2 Negative
PA25	AP_LVDS_TNCLK	1V8	LVDS_TNCLK	S	IO	N	LVDS	LVDS Transmit Negative Clock
PA26	AP_LVDS_TN3	1V8	LVDS_TN3	S	IO	N	LVDS	LVDS Transmit Channel 3 Negative
PA27	AP_LVDS_TN4	1V8	LVDS_TN4	S	IO	N	LVDS	LVDS Transmit Channel 4 Negative
PA28	GND	0V0	GND	NA	0V0	-	GND	Ground
PA29	AP_HDMI_CEC	3V3	SA3	S	GPIO	N	HDMI	HDMI Consumer Electronics Control
PA30	AP_HDMI_TX2N	1V8	HDMI_TXN2	S	O	N	HDMI	HDMI Transmit Channel 1 Negative
PA31	AP_HDMI_TX1N	1V8	HDMI_TXN1	S	O	N	HDMI	HDMI Transmit Channel 0 Negative
PA32	AP_HDMI_TX0N	1V8	HDMI_TXN0	S	O	N	HDMI	HDMI Transmit Channel 2 Negative
PA33	AP_HDMI_TXCN	1V8	HDMI_TXNCLK	S	O	N	HDMI	HDMI Transmit Negative Clock
PA34	GND	0V0	GND	NA	0V0	-	GND	Ground
PA35	AP_OTG_DM	3V3	USB2.0OTG_DM	S	IO	N	USB OTG	USB OTG Data Minus
PA36	AP_USBH_DM	3V3	USB2.0HOST_DM	S	IO	N	USB HOST	USB HOST Data Plus
PA37	AP_GPA13	3V3	DISD12	S	GPIO	N	GPIO	Generic GPIO
PA38	AP_HSIC_STROBE	1V2	USBHSIC_STROBE	S	IO	N	HSIC	HSIC Strobe
PA39	AP_GPA14	3V3	DISD13	S	GPIO	N	GPIO	Generic GPIO
PA40	AP_GPA9	3V3	DISD8	S	GPIO	N	GPIO	Generic GPIO
PA41	AP_GPA15	3V3	DISD14	S	GPIO	N	GPIO	Generic GPIO
PA42	AP_GPA12	3V3	DISD11	S	GPIO	N	GPIO	Generic GPIO
PA43	GND	0V0	GND	NA	0V0	-	GND	Ground
PB1	GND	0V0	GND	NA	0V0	-	GND	Ground
PB2	GMAC_TXD0	3V3	GMAC_TXD0	S	GPIO	N	GMAC	GMAC Transmit Data 0
PB3	GMAC_TXD2	3V3	GMAC_TXD2	S	GPIO	N	GMAC	GMAC Transmit Data 2

BAL LOC	BALL Name	Power	Default	I/O Type	I/O	PU/PD	Group	Function
PB4	GMAC_MDC	3V3	GMAC_MDC	S	GPIO	N	GMAC	GMAC MDC
PB5	GMAC_RXCLK	3V3	GMAC_RXCLK	S	GPIO	N	GMAC	GMAC Receive Clock
PB6	GMAC_RXD3	3V3	GMAC_RXD3	S	GPIO	N	GMAC	GMAC Receive Data 3
PB7	GMAC_RXD1	3V3	GMAC_RXD1	S	GPIO	N	GMAC	GMAC Receive Data 1
PB8	GMAC_MDIO	3V3	GMAC_MDIO	S	GPIO	N	GMAC	GMAC MDIO
PB9	GND	0V0	GND	NA	0V0	-	GND	Ground
PB10	AP_MIPICSI_DPCLK	1V8	MIPICSI_DPCLK	S	IO	N	CSI	MIPI CSI Data Positive Clock
PB11	AP_MIPICSI_DP0	1V8	MIPICSI_DP0	S	IO	N	CSI	MIPI CSI Data Positive 0
PB12	AP_MIPICSI_DP1	1V8	MIPICSI_DP1	S	IO	N	CSI	MIPI CSI Data Positive 1
PB13	AP_MIPICSI_DP2	1V8	MIPICSI_DP2	S	IO	N	CSI	MIPI CSI Data Positive 2
PB14	AP_MIPICSI_DP3	1V8	MIPICSI_DP3	S	IO	N	CSI	MIPI CSI Data Positive 3
PB15	GND	0V0	GND	NA	0V0	-	GND	Ground
PB16	AP_MIPIDSI_DPCLK	1V8	MIPIDSI_DPCLK	S	IO	N	DSI	MIPI DSI Data Positive Clock
PB17	AP_MIPIDSI_DP0	1V8	MIPIDSI_DP0	S	IO	N	DSI	MIPI DSI Data Positive 0
PB18	AP_MIPIDSI_DP1	1V8	MIPIDSI_DP1	S	IO	N	DSI	MIPI DSI Data Positive 1
PB19	AP_MIPIDSI_DP2	1V8	MIPIDSI_DP2	S	IO	N	DSI	MIPI DSI Data Positive 2
PB20	AP_MIPIDSI_DP3	1V8	MIPIDSI_DP3	S	IO	N	DSI	MIPI DSI Data Positive 3
PB21	GND	0V0	GND	NA	0V0	-	GND	Ground
PB22	AP_LVDS_TP0	1V8	LVDS_TP0	S	IO	N	LVDS	LVDS Transmit Channel 0 Positive
PB23	AP_LVDS_TP1	1V8	LVDS_TP1	S	IO	N	LVDS	LVDS Transmit Channel 1 Positive
PB24	AP_LVDS_TP2	1V8	LVDS_TP2	S	IO	N	LVDS	LVDS Transmit Channel 2 Positive
PB25	AP_LVDS_TPCLK	1V8	LVDS_TPCLK	S	IO	N	LVDS	LVDS Transmit Positive Clock
PB26	AP_LVDS_TP3	1V8	LVDS_TP3	S	IO	N	LVDS	LVDS Transmit Channel 3 Positive
PB27	AP_LVDS_TP4	1V8	LVDS_TP4	S	IO	N	LVDS	LVDS Transmit Channel 4 Positive
PB28	GND	0V0	GND	NA	0V0	-	GND	Ground
PB29	AP_HDMI_HPD	3V3	HDMI_HOT5V	S	I	N	HDMI	HDMI Hot 5V
PB30	AP_HDMI_TX2P	1V8	HDMI_TXP2	S	O	N	HDMI	HDMI Transmit Channel 1 Positive
PB31	AP_HDMI_TX1P	1V8	HDMI_TXP1	S	O	N	HDMI	HDMI Transmit Channel 0 Positive
PB32	AP_HDMI_TX0P	1V8	HDMI_TXP0	S	O	N	HDMI	HDMI Transmit Channel 2 Positive
PB33	AP_HDMI_TXCP	1V8	HDMI_TXPCLK	S	O	N	HDMI	HDMI Transmit Positive Clock
PB34	GND	0V0	GND	NA	0V0	-	GND	Ground
PB35	AP_OTG_DP	3V3	USB2.0OTG_DP	S	IO	N	USB OTG	USB OTG Data Plus
PB36	AP_USBH_DP	3V3	USB2.0HOST_D P	S	IO	N	USB HOST	USB HOST Data Minus
PB37	AP_OTG_ID	-	USB2.0OTG_ID	S	IO	N	USB HOST	USB HOST ID
PB38	AP_HSIC_DATA	1V2	USBHSIC_DATA	S	IO	N	HSIC	HSIC Data
PB39	AP_GPA4	3V3	DISD3	S	GPIO	N	GPIO	Generic GPIO
PB40	AP_GPA5	3V3	DISD4	S	GPIO	N	GPIO	Generic GPIO
PB41	AP_GPA16	3V3	DISD15	S	GPIO	N	GPIO	Generic GPIO
PB42	AP_GPA11	3V3	DISD10	S	GPIO	N	GPIO	Generic GPIO
PB43	GND	0V0	GND	NA	0V0	-	GND	Ground

## BOTTOM BALL ARRAY

Table 2. BOTTOM BALL ARRAY

BALL LOC	BALL Name	Power	Default	I/O Type	I/O	PU/PD	Group	Function
PAK1	AP_I2S0_DOUT	3V3	I2SDOUT0	S	GPIO	N	I2S0	I2S 0 Data Out
PAK2	AP_I2S0_BCLK	3V3	I2SBCLK0	S	GPIO	N	I2S0	I2S 0 Bit Clock
PAK3	AP_GPC11_SPI2_MISO	3V3	SA11	S	GPIO	N	SPI2	SPI 2 Receive Data
PAK4	AP_GPC9_SPI2_CLK	3V3	SA9	S	GPIO	N	SPI2	SPI 2 Clock
PAK5	AP_SPI0_MISO	3V3	SPIRXD0	S	GPIO	N	SPI0	SPI 0 Receive Data
PAK6	AP_SPI0_CLK	3V3	SPICLK0	S	GPIO	N	SPI0	SPI 0 Clock
PAK7	AP_GPC14_PWM2	3V3	SA14	S	GPIO	N	PWM	PWM 2
PAK8	AP_GPD6_SCL	3V3	SCL2	S	GPIO	N	I2C	I2C SCL
PAK9	AP_GPD4_SCL1	3V3	SCL1	S	GPIO	N	I2C	I2C SCL 1
PAK10	AP_GPD2_SCL0	3V3	SCL0	S	GPIO	N	I2C	I2C SCL 0
PAK11	AP_GPA23_HDMI_I2C_SCL	3V3	DISD22	S	GPIO	N	I2C	HDMI I2C SCL
PAK12	ZB_JTMS	3V3	-	-	-	-	ZIGBEE	ZIGBEE JTAG TMS
PAK13	ZB_JTCK	3V3	-	-	-	-	ZIGBEE	ZIGBEE JTAG TCK
PAK14	ZB_PC0	3V3	-	-	-	-	ZIGBEE	ZIGBEE Control
PAK15	ZB_PA4	3V3	-	-	-	-	ZIGBEE	ZIGBEE Control
PAK16	GND	0V0	GND	NA	0V0	-	GND	Ground
PAK17	VCC3P3_SYS	3V3	-	NA	3V3	-	POWER	DCDC3, VCC 3V3 Power
PAK18	VCC3P3_SYS	3V3	-	NA	3V3	-	POWER	DCDC3, VCC 3V3 Power
PAK19	AP_NBATTFF	3V3	AP_NBATTFF	-	NA	-	MISC	Battery
PAK20	AP_GPE2	3V3	VID0_6	S	GPIO	N	MISC	Miscellaneous
PAK21	AP_GPE1	3V3	VID0_5	S	GPIO	N	MISC	Miscellaneous
PAK22	AP_UARTTX3	3V3	UARTTXD3	S	GPIO	N	UART	UART Transmit Data 3
PAK23	AP_UARTTX4	3V3	SD13	S	GPIO	N	UART	UART Transmit Data 4
PAK24	AP_UARTTX5	3V3	SD15	S	GPIO	N	UART	UART Transmit Data 5
PAK25	AP_GPB0_VID1_1_I2SLRCK1	3V3	VID1_1	S	GPIO	N	I2S1	I2S 1 Left Right Clock
PAK26	AP_GPA28_I2SMCLK1	3V3	VICLK1	S	GPIO	N	I2S1	I2S 1 Master Clock
PAK27	AP_GPA30_VID1_0_I2SBCLK1	3V3	VID1_0	S	GPIO	N	I2S1	I2S 1 Bit Clock
PAK28	AP_SD0_CMD	3V3	SDCMD0	S	GPIO	N	SD/MMC	SD Command
PAK29	AP_SD0_D1	3V3	SDDAT0_1	S	GPIO	N	SD/MMC	SD Data 1
PAK30	AP_SD0_CLK	3V3	SDCLK0	S	GPIO	N	SD/MMC	SD Clock
PAK31	NO BALL	-	-	-	-	-	NO BALL	NA
PAK32	AP_GPB13_SD0_BOOT	3V3	SD0	S	GPIO	N	BOOTING	Select Booting Scenario
PAK33	AP_GPC17	3V3	SA17	S	GPIO	N	GPIO	Generic GPIO
PAK34	AP_GPC0	3V3	SA0	S	GPIO	N	GPIO	Generic GPIO
PAK35	AP_GPC26	3V3	RDNWR	S	GPIO	PU	GPIO	Generic GPIO
PAK36	AP_GPB8	3V3	VID1_5	S	GPIO	N	GPIO	Generic GPIO
PAK37	AP_GPB14	3V3	RNB0	S	GPIO	N	MISC	Miscellaneous
PAK38	AP_GPA20	3V3	DISD19	S	GPIO	N	GPIO	Generic GPIO
PAK39	AP_GPA18	3V3	DISD17	S	GPIO	N	GPIO	Generic GPIO
PAK40	AP_GPA21	3V3	DISD20	S	GPIO	N	GPIO	Generic GPIO
PAK41	AP_GPA10	3V3	DISD9	S	GPIO	N	GPIO	Generic GPIO
PAK42	AP_GPA6	3V3	DISD5	S	GPIO	N	GPIO	Generic GPIO
PAK43	BT_PCM_D_IN	3V3	-	-	-	-	BT PCM	PCM Data In
PAL1	AP_I2S0_DIN	3V3	I2SDIN0	S	GPIO	N	I2S0	I2S 0 Data In
PAL2	AP_I2S0_MCLK	3V3	I2SMCLK0	S	GPIO	N	I2S0	I2S 0 Master Clock
PAL3	AP_GPC12_SPI2_MOSI	3V3	SA12	S	GPIO	N	SPI2	SPI 2 Transmit Data
PAL4	AP_GPC10_SPI2_CS	3V3	SA10	S	GPIO	PU	SPI2	SPI 2 Frame
PAL5	AP_SPI0_MOSI	3V3	SPITXD0	S	GPIO	N	SPI0	SPI 0 Transmit Data
PAL6	AP_SPI0_CS	3V3	SPIFRM0	S	GPIO	N	SPI0	SPI 0 Frame

BALL LOC	BALL Name	Power	Default	I/O Type	I/O	PU/PD	Group	Function
PAL7	AP_GPD1_PWM0	3V3	PWM0	S	GPIO	N	PWM	PWM 0
PAL8	AP_GPD7_SDA	3V3	SDA2	S	GPIO	N	I2C	I2C SDA
PAL9	AP_GPD5_SDA1	3V3	SDA1	S	GPIO	N	I2C	I2C SDA 1
PAL10	AP_GPD3_SDA0	3V3	SDA0	S	GPIO	N	I2C	I2C SDA 0
PAL11	AP_GPA24_HDMI_I2C_SDA	3V3	DISD23	S	GPIO	N	I2C	HDMI I2C SDA
PAL12	ZB_JTDI	3V3	-	-	-	-	ZIGBEE	ZIGBEE JTAG TDI
PAL13	ZB_JTDO	3V3	-	-	-	-	ZIGBEE	ZIGBEE JTAG TDO
PAL14	ZB_RSTN	3V3	SA8	S	GPIO	N	ZIGBEE	ZIGBEE Reset
PAL15	ZB_PA5	3V3	NSCS1	S	GPIO	PU	ZIGBEE	ZIGBEE Control
PAL16	GND	0V0	GND	NA	0V0	-	GND	Ground
PAL17	VCC3P3_SYS	3V3	-	NA	3V3	-	POWER	DCDC3, VCC 3V3 Power
PAL18	VCC3P3_SYS	3V3	-	NA	3V3	-	POWER	DCDC3, VCC 3V3 Power
PAL19	AP_VDDPWON	3V3	VDDPWON	S	O	N	MISC	VDD Power On
PAL20	AP_GPE3	3V3	VID0_7	S	GPIO	N	MISC	Miscellaneous
PAL21	AP_GPE0	3V3	VID0_4	S	GPIO	N	MISC	Miscellaneous
PAL22	AP_UARTRX3	3V3	UARTRXD3	S	GPIO	N	UART	UART Receive Data 3
PAL23	AP_UARTRX4	3V3	SD12	S	GPIO	N	UART	UART Receive Data 4
PAL24	AP_UARTRX5	3V3	SD14	S	GPIO	N	UART	UART Receive Data 5
PAL25	AP_GPD31	3V3	VID0_3	S	GPIO	N	MISC	Miscellaneous
PAL26	AP_GPB9_I2SDIN1	3V3	VID1_6	S	GPIO	N	I2S1	I2S 1 Data In
PAL27	AP_GPB6 VID1_4_I2SDOUT1	3V3	VID1_4	S	GPIO	N	I2S1	I2S 1 Data Out
PAL28	AP_SD0_D3	3V3	SDDAT0_3	S	GPIO	N	SD/MMC	SD Data 3
PAL29	AP_SD0_D2	3V3	SDDAT0_2	S	GPIO	N	SD/MMC	SD Data 2
PAL30	AP_SD0_D0	3V3	SDDAT0_0	S	GPIO	N	SD/MMC	SD Data 0
PAL31	AP_GPB4 VID1_3_BOOT	3V3	VID1_3	S	GPIO	N	BOOTING	Select Booting Scenario
PAL32	AP_GPB15_SD1_BOOT	3V3	SD1	S	GPIO	N	BOOTING	Select Booting Scenario
PAL33	AP_GPD8	3V3	SD8	S	GPIO	N	GPIO	Generic GPIO
PAL34	AP_GPE30	3V3	NSOE	S	GPIO	PU	GPIO	Generic GPIO
PAL35	AP_GPC27	3V3	NSDQM	S	GPIO	PU	GPIO	Generic GPIO
PAL36	AP_GPB22	3V3	SD6	S	GPIO	N	GPIO	Generic GPIO
PAL37	AP_GPB16	3V3	NNFOE0	S	GPIO	N	MISC	Miscellaneous
PAL38	AP_GPB23	3V3	SD7	S	GPIO	N	GPIO	Generic GPIO
PAL39	AP_GPA22	3V3	DISD21	S	GPIO	N	GPIO	Generic GPIO
PAL40	AP_GPA19	3V3	DISD18	S	GPIO	N	GPIO	Generic GPIO
PAL41	AP_GPA17	3V3	DISD16	S	GPIO	N	GPIO	Generic GPIO
PAL42	AP_GPA3	3V3	DISD2	S	GPIO	N	GPIO	Generic GPIO
PAL43	BT_PCM_CLK	3V3	-	-	-	-	BT PCM	PCM Clock

## LEFT BALL ARRAY

Table 3. LEFT BALL ARRAY

BALL LOC	BALL Name	Power	Default	I/O Type	I/O	PU/PD	Group	Function
PC1	GND	0V0	GND	NA	0V0	-	GND	Ground
PC2	NO BALL	-	-	-	-	-	NO BALL	NA
PD1	GND	0V0	GND	NA	0V0	-	GND	Ground
PD2	NO BALL	-	-	-	-	-	NO BALL	NA
PE1	GND	0V0	GND	NA	0V0	-	GND	Ground
PE2	GND	0V0	GND	NA	0V0	-	GND	Ground
PF1	GND	0V0	GND	NA	0V0	-	GND	Ground
PF2	GND	0V0	GND	NA	0V0	-	GND	Ground
PG1	GND	0V0	GND	NA	0V0	-	GND	Ground
PG2	NO BALL	-	-	-	-	-	NO BALL	NA
PH1	GND	0V0	GND	NA	0V0	-	GND	Ground
PH2	NO BALL	-	-	-	-	-	NO BALL	NA
PJ1	GND	0V0	GND	NA	0V0	-	GND	Ground
PJ2	GND	0V0	GND	NA	0V0	-	GND	Ground
PK1	GND	0V0	GND	NA	0V0	-	GND	Ground
PK2	GND	0V0	GND	NA	0V0	-	GND	Ground
PL1	GND	0V0	GND	NA	0V0	-	GND	Ground
PL2	GND	0V0	GND	NA	0V0	-	GND	Ground
PM1	GND	0V0	GND	NA	0V0	-	GND	Ground
PM2	GND	0V0	GND	NA	0V0	-	GND	Ground
PN1	GND	0V0	GND	NA	0V0	-	GND	Ground
PN2	GND	0V0	GND	NA	0V0	-	GND	Ground
PP1	GND	0V0	GND	NA	0V0	-	GND	Ground
PP2	NO BALL	-	-	-	-	-	NO BALL	NA
PR1	GND	0V0	GND	NA	0V0	-	GND	Ground
PR2	GND	0V0	GND	NA	0V0	-	GND	Ground
PT1	VCC1P8_LDO4	0.9-3.5	-	NA	1V8	-	POWER	1V8 LDO, 25mV Step, 300mA Max
PT2	GND	0V0	GND	NA	0V0	-	GND	Ground
PU1	VCC1P8_LDO4	0.9-3.5	-	NA	1V8	-	POWER	1V8 LDO, 25mV Step, 300mA Max
PU2	NO BALL	-	-	-	-	-	NO BALL	NA
PV1	VCC1P8_LDO4	0.9-3.5	-	NA	1V8	-	POWER	1V8 LDO, 25mV Step, 300mA Max
PV2	NO BALL	-	-	-	-	-	NO BALL	NA
PW1	AP_ADC4	1V8	ADC4	S	IO	N	ADC	ADC Channel 4
PW2	AP_ADC5	1V8	ADC5	S	IO	N	ADC	ADC Channel 5
PY1	AP_ADC0	1V8	ADC0	S	IO	N	ADC	ADC Channel 0
PY2	AP_ADC1	1V8	ADC1	S	IO	N	ADC	ADC Channel 1
PAA1	AP_ADC2	1V8	ADC2	S	IO	N	ADC	ADC Channel 2
PAA2	AP_ADC3	1V8	ADC3	S	IO	N	ADC	ADC Channel 3
PAB1	GND	0V0	GND	NA	0V0	-	GND	Ground
PAB2	GND	0V0	GND	NA	0V0	-	GND	Ground
PAC1	AP_TCK	3V3	TCLK	S	GPIO	PD	JTAG	JTAG TCK
PAC2	AP_TMS	3V3	TMS	S	GPIO	PU	JTAG	JTAG TMS
PAD1	AP_TDO	3V3	TDO	S	GPIO	N	JTAG	JTAG TDO
PAD2	AP_TDI	3V3	TDI	S	GPIO	PU	JTAG	JTAG TDI
PAE1	AP_NTRST	3V3	NTRST	S	GPIO	PU	JTAG	JTAG NTRST
PAE2	AP_AGP2_RTC_INT_N	3V3	ALIVEGPIO2	S	IO	N	KEY/ALIVE	RTC Interrupt
PAF1	AP_PWRKEY	3V3	ALIVEGPIO0	S	IO	N	KEY/ALIVE	Power Key part of AliveGPIO
PAF2	AP_AGP1_HOMEKEY	3V3	ALIVEGPIO1	S	IO	N	KEY/ALIVE	Home Key part of AliveGPIO
PAG1	AP_NRESET	3V3	NRESET	S	I	N	KEY	Reset

BALL LOC	BALL Name	Power	Default	I/O Type	I/O	PU/PD	Group	Function
PAG2	AP_GPA25_BACKKEY	3V3	DISVSYNC	S	GPIO	N	KEY	Back Key
PAH1	AP_GPA26_VOLUP	3V3	DISHSYNC	S	GPIO	N	KEY	Volume Up
PAH2	AP_GPA0_MENUKEY	3V3	DISCLK	S	GPIO	N	KEY	Menu Key
PAJ1	AP_I2S0_LRCLK	3V3	I2SLRCLK0	S	GPIO	N	I2S0	I2S 0 Left Right Clock
PAJ2	AP_GPA27_VOLDOWN	3V3	DISDE	S	GPIO	N	KEY	Volume Down

## RIGHT BALL ARRAY

Table 4. RIGHT BALL ARRAY

BALL LOC	BALL Name	Power	Default	I/O Type	I/O	PU/PD	Group	Function
PC42	GND	0V0	GND	NA	0V0	-	GND	Ground
PC43	GND	0V0	GND	NA	0V0	-	GND	Ground
PD42	VCC5P0_OTGVBUS	-	-	NA	5V0	-	POWER	USB2.0 OTG BUS Power
PD43	VCC5P0_OTGVBUS	-	-	NA	5V0	-	POWER	USB2.0 OTG BUS Power
PE42	VCC2P8_LDO7	0.9-3.5	-	NA	2V8	-	POWER	2V8 LDO, 25mV Step, 200mA Max
PE43	VCC2P8_LDO7	0.9-3.5	-	NA	2V8	-	POWER	2V8 LDO, 25mV Step, 200mA Max
PF42	VCC2P8_LDO7	0.9-3.5	-	NA	2V8	-	POWER	2V8 LDO, 25mV Step, 200mA Max
PF43	GND	0V0	GND	NA	0V0	-	GND	Ground
PG42	GND	0V0	GND	NA	0V0	-	GND	Ground
PG43	GND	0V0	GND	NA	0V0	-	GND	Ground
PH42	VCC_LDO5	0.6-3.5	-	NA		-	POWER	User Controlled LDO, 0.6-3.5V, 25mV Step, 300mA Max
PH43	VCC_LDO5	0.6-3.5	-	NA		-	POWER	User Controlled LDO, 0.6-3.5V, 25mV Step, 300mA Max
PJ42	VCC_LDO5	0.6-3.5	-	NA		-	POWER	User Controlled LDO, 0.6-3.5V, 25mV Step, 300mA Max
PJ43	VCC_LDO2	0.9-3.5	-	NA		-	POWER	User Controlled LDO, 0.9-3.5V, 25mV Step, 300mA Max
PK42	VCC_LDO2	0.9-3.5	-	NA		-	POWER	User Controlled LDO, 0.9-3.5V, 25mV Step, 300mA Max
PK43	VCC_LDO2	0.9-3.5	-	NA		-	POWER	User Controlled LDO, 0.9-3.5V, 25mV Step, 300mA Max
PL42	GND	0V0	GND	NA	0V0	-	GND	Ground
PL43	GND	0V0	GND	NA	0V0	-	GND	Ground
PM42	VCC_LDO1	0.9-3.5	-	NA		-	POWER	User Controlled LDO, 0.9-3.5V, 25mV Step, 300mA Max
PM43	VCC_LDO1	0.9-3.5	-	NA		-	POWER	User Controlled LDO, 0.9-3.5V, 25mV Step, 300mA Max
PN42	VCC_LDO1	0.9-3.5	-	NA		-	POWER	User Controlled LDO, 0.9-3.5V, 25mV Step, 300mA Max
PN43	GND	0V0	GND	NA	0V0	-	GND	Ground
PP42	VCC1P2_LDO10	0.9-3.5	-	NA	1V2	-	POWER	1V2 LDO, 25mV Step, 200mA Max
PP43	GND	0V0	GND	NA	0V0	-	GND	Ground
PR42	VCC1P2_LDO10	0.9-3.5	-	NA	1V2	-	POWER	1V2 LDO, 25mV Step, 200mA Max
PR43	VCC1P2_LDO10	0.9-3.5	-	NA	1V2	-	POWER	1V2 LDO, 25mV Step, 200mA Max
PT42	VCC_LDO9	0.9-3.5	-	NA		-	POWER	User Controlled LDO, 0.9-3.5V, 25mV Step, 200mA Max
PT43	GND	0V0	GND	NA	0V0	-	GND	Ground
PU42	VCC_LDO9	0.9-3.5	-	NA		-	POWER	User Controlled LDO, 0.9-3.5V, 25mV Step, 200mA Max
PU43	VCC_LDO9	0.9-3.5	-	NA		-	POWER	User Controlled LDO, 0.9-3.5V, 25mV Step, 200mA Max
PV42	VBAT_MAIN	VBAT	-	NA		-	POWER	Main Power Supply for Module
PV43	VBAT_MAIN	VBAT	-	NA		-	POWER	Main Power Supply for Module

BALL LOC	BALL Name	Power	Default	I/O Type	I/O	PU/PD	Group	Function
PW42	VBAT_MAIN	VBAT	-	NA		-	POWER	Main Power Supply for Module
PW43	VBAT_MAIN	VBAT	-	NA		-	POWER	Main Power Supply for Module
PY42	VBAT_MAIN	VBAT	-	NA		-	POWER	Main Power Supply for Module
PY43	VBAT_MAIN	VBAT	-	NA		-	POWER	Main Power Supply for Module
PAA42	VBAT_MAIN	VBAT	-	NA		-	POWER	Main Power Supply for Module
PAA43	VBAT_MAIN	VBAT	-	NA		-	POWER	Main Power Supply for Module
PAB42	VBAT_MAIN	VBAT	-	NA		-	POWER	Main Power Supply for Module
PAB43	VBAT_MAIN	VBAT	-	NA		-	POWER	Main Power Supply for Module
PAC42	GND	0V0	GND	NA	0V0	-	GND	Ground
PAC43	GND	0V0	GND	NA	0V0	-	GND	Ground
PAD42	VCC3V3_LDO8	0.9-3.5	-	NA	3V3	-	POWER	User Controlled LDO, 0.9-3.5V, 25mV Step, 200mA Max
PAD43	VCC3V3_LDO8	0.9-3.5	-	NA	3V3	-	POWER	User Controlled LDO, 0.9-3.5V, 25mV Step, 200mA Max
PAE42	GND	0V0	GND	NA	0V0	-	GND	Ground
PAE43	VCC3V3_LDO8	0.9-3.5	-	NA	3V3	-	POWER	User Controlled LDO, 0.9-3.5V, 25mV Step, 200mA Max
PAF42	GND	0V0	GND	NA	0V0	-	GND	Ground
PAF43	GND	0V0	GND	NA	0V0	-	GND	Ground
PAG42	AP_GPB11	3V3	CLE0	S	GPI O	N	GPIO	Generic GPIO
PAG43	AP_GPB18	3V3	NNFWE0	S	GPI O	N	GPIO	Generic GPIO
PAH42	AP_GPC25	3V3	NSWAIT	S	GPI O	PU	GPIO	Generic GPIO
PAH43	AP_GPE31	3V3	NSWE	S	GPI O	PU	GPIO	Generic GPIO
PAJ42	BT_PCM_D_OUT	3V3	-	-	-	-	BT PCM	PCM Data Out
PAJ43	BT_PCM_LRCK	3V3	-	-	-	-	BT PCM	PCM LR Clock

# ARTIK 710 MODULE FUNCTIONAL INTERFACES

This section shows the functional interfaces that are available at the PADS of the ARTIK 710 Module. The functions provided are related to the development environment used. Depending on your project, you can always choose to reprogram some of the GPIOs that are currently assigned to the pre-defined functional interfaces.

## ADC

Table 5. ADC

BALL LOC	BALL Name	Power	Default	I/O Type	I/O	PU/PD	Function
PW1	AP_ADC4	1V8	ADC4	S	IO	N	ADC Channel 4
PW2	AP_ADC5	1V8	ADC5	S	IO	N	ADC Channel 5
PY1	AP_ADC0	1V8	ADC0	S	IO	N	ADC Channel 0
PY2	AP_ADC1	1V8	ADC1	S	IO	N	ADC Channel 1
PAA1	AP_ADC2	1V8	ADC2	S	IO	N	ADC Channel 2
PAA2	AP_ADC3	1V8	ADC3	S	IO	N	ADC Channel 3

## BOOTING

Table 6. Booting

BALL LOC	BALL Name	Power	Default	I/O Type	I/O	PU/PD	Function
PAK32	AP_GPB13_SD0_BOOT	3V3	SD0	S	GPIO	N	Select Booting Scenario
PAL31	AP_GPB4_VID1_3_BOOT	3V3	VID1_3	S	GPIO	N	Select Booting Scenario
PAL32	AP_GPB15_SD1_BOOT	3V3	SD1	S	GPIO	N	Select Booting Scenario

## BLUETOOTH PCM

Table 7. Bluetooth PCM

BALL LOC	BALL Name	Power	Default	I/O Type	I/O	PU/PD	Function
PAK43	BT_PCM_D_IN	3V3	-	-	-	-	PCM Data In
PAL43	BT_PCM_CLK	3V3	-	-	-	-	PCM Clock
PAJ42	BT_PCM_D_OUT	3V3	-	-	-	-	PCM Data Out
PAJ43	BT_PCM_LRCK	3V3	-	-	-	-	PCM LR Clock

## MIPI CSI

Table 8. MIPI CSI

BALL LOC	BALL Name	Power	Default	I/O Type	I/O	PU/PD	Function
PA10	AP_MIPICSI_DNCLK	1V8	MIPICSI_DNCLK	S	IO	N	MIPI CSI Data Negative Clock
PA11	AP_MIPICSI_DN0	1V8	MIPICSI_DN0	S	IO	N	MIPI CSI Data Negative 0
PA12	AP_MIPICSI_DN1	1V8	MIPICSI_DN1	S	IO	N	MIPI CSI Data Negative 1
PA13	AP_MIPICSI_DN2	1V8	MIPICSI_DN2	S	IO	N	MIPI CSI Data Negative 2
PA14	AP_MIPICSI_DN3	1V8	MIPICSI_DN3	S	IO	N	MIPI CSI Data Negative 3
PB10	AP_MIPICSI_DPCLK	1V8	MIPICSI_DPCLK	S	IO	N	MIPI CSI Data Positive Clock
PB11	AP_MIPICSI_DP0	1V8	MIPICSI_DP0	S	IO	N	MIPI CSI Data Positive 0
PB12	AP_MIPICSI_DP1	1V8	MIPICSI_DP1	S	IO	N	MIPI CSI Data Positive 1
PB13	AP_MIPICSI_DP2	1V8	MIPICSI_DP2	S	IO	N	MIPI CSI Data Positive 2
PB14	AP_MIPICSI_DP3	1V8	MIPICSI_DP3	S	IO	N	MIPI CSI Data Positive 3

## MIPI DSI

Table 9. MIPI DSI

BALL LOC	BALL Name	Power	Default	I/O Type	I/O	PU/PD	Function
PA16	AP_MIPIDSI_DNCLK	1V8	MIPIDSI_DNCLK	S	IO	N	MIPI DSI Data Negative Clock
PA17	AP_MIPIDSI_DN0	1V8	MIPIDSI_DN0	S	IO	N	MIPI DSI Data Negative 0
PA18	AP_MIPIDSI_DN1	1V8	MIPIDSI_DN1	S	IO	N	MIPI DSI Data Negative 1
PA19	AP_MIPIDSI_DN2	1V8	MIPIDSI_DN2	S	IO	N	MIPI DSI Data Negative 2
PA20	AP_MIPIDSI_DN3	1V8	MIPIDSI_DN3	S	IO	N	MIPI DSI Data Negative 3
PB16	AP_MIPIDSI_DPCLK	1V8	MIPIDSI_DPCLK	S	IO	N	MIPI DSI Data Positive Clock
PB17	AP_MIPIDSI_DP0	1V8	MIPIDSI_DP0	S	IO	N	MIPI DSI Data Positive 0
PB18	AP_MIPIDSI_DP1	1V8	MIPIDSI_DP1	S	IO	N	MIPI DSI Data Positive 1
PB19	AP_MIPIDSI_DP2	1V8	MIPIDSI_DP2	S	IO	N	MIPI DSI Data Positive 2
PB20	AP_MIPIDSI_DP3	1V8	MIPIDSI_DP3	S	IO	N	MIPI DSI Data Positive 3

## GMAC

Table 10. GMAC

BALL LOC	BALL Name	Power	Default	I/O Type	I/O	PU/PD	Function
PA1	GMAC_TXEN	3V3	GMAC_TXEN	S	GPIO	N	GMAC Transmit Enable
PA2	GMAC_TXD1	3V3	GMAC_TXD1	S	GPIO	N	GMAC Transmit Data 1
PA3	GMAC_TXD3	3V3	GMAC_TXD3	S	GPIO	N	GMAC Transmit Data 3
PA5	GMAC_GTXCLK	3V3	GMAC_GTXCLK	S	GPIO	N	GMAC Transmit Clock
PA6	GMAC_RXDV	3V3	GMAC_RXDV	S	GPIO	N	GMAC Receive Enable
PA7	GMAC_RXD2	3V3	GMAC_RXD2	S	GPIO	N	GMAC Receive Data 2
PA8	GMAC_RXD0	3V3	GMAC_RXD0	S	GPIO	N	GMAC Receive Data 0
PB2	GMAC_TXD0	3V3	GMAC_TXD0	S	GPIO	N	GMAC Transmit Data 0
PB3	GMAC_TXD2	3V3	GMAC_TXD2	S	GPIO	N	GMAC Transmit Data 2
PB4	GMAC_MDC	3V3	GMAC_MDC	S	GPIO	N	GMAC MDC
PB5	GMAC_RXCLK	3V3	GMAC_RXCLK	S	GPIO	N	GMAC Receive Clock
PB6	GMAC_RXD3	3V3	GMAC_RXD3	S	GPIO	N	GMAC Receive Data 3
PB7	GMAC_RXD1	3V3	GMAC_RXD1	S	GPIO	N	GMAC Receive Data 1
PB8	GMAC_MDIO	3V3	GMAC_MDIO	S	GPIO	N	GMAC MDIO

## GPIO

Table 11. GPIO

BALL LOC	BALL Name	Power	Default	I/O Type	I/O	PU/PD	Function
PA37	AP_GPA13	3V3	DISD12	S	GPIO	N	Generic GPIO
PA39	AP_GPA14	3V3	DISD13	S	GPIO	N	Generic GPIO
PA40	AP_GPA9	3V3	DISD8	S	GPIO	N	Generic GPIO
PA41	AP_GPA15	3V3	DISD14	S	GPIO	N	Generic GPIO
PA42	AP_GPA12	3V3	DISD11	S	GPIO	N	Generic GPIO
PB39	AP_GPA4	3V3	DISD3	S	GPIO	N	Generic GPIO
PB40	AP_GPA5	3V3	DISD4	S	GPIO	N	Generic GPIO
PB41	AP_GPA16	3V3	DISD15	S	GPIO	N	Generic GPIO
PAK33	AP_GPC17	3V3	SA17	S	GPIO	N	Generic GPIO
PAK34	AP_GPC0	3V3	SA0	S	GPIO	N	Generic GPIO
PAK35	AP_GPC26	3V3	RDNWR	S	GPIO	PU	Generic GPIO
PAK36	AP_GPB8	3V3	VID1_5	S	GPIO	N	Generic GPIO
PAK38	AP_GPA20	3V3	DISD19	S	GPIO	N	Generic GPIO
PAK39	AP_GPA18	3V3	DISD17	S	GPIO	N	Generic GPIO

BALL LOC	BALL Name	Power	Default	I/O Type	I/O	PU/PD	Function
PAK40	AP_GPA21	3V3	DISD20	S	GPIO	N	Generic GPIO
PAK41	AP_GPA10	3V3	DISD9	S	GPIO	N	Generic GPIO
PAK42	AP_GPA6	3V3	DISD5	S	GPIO	N	Generic GPIO
PAL33	AP_GPD8	3V3	SD8	S	GPIO	N	Generic GPIO
PAL34	AP_GPE30	3V3	NSOE	S	GPIO	PU	Generic GPIO
PAL35	AP_GPC27	3V3	NSDQM	S	GPIO	PU	Generic GPIO
PAL36	AP_GPB22	3V3	SD6	S	GPIO	N	Generic GPIO
PAL38	AP_GPB23	3V3	SD7	S	GPIO	N	Generic GPIO
PAL39	AP_GPA22	3V3	DISD21	S	GPIO	N	Generic GPIO
PAL40	AP_GPA19	3V3	DISD18	S	GPIO	N	Generic GPIO
PAL41	AP_GPA17	3V3	DISD16	S	GPIO	N	Generic GPIO
PAL42	AP_GPA3	3V3	DISD2	S	GPIO	N	Generic GPIO
PB42	AP_GPA11	3V3	DISD10	S	GPIO	N	Generic GPIO
PAG42	AP_GPB11	3V3	CLE0	S	GPIO	N	Generic GPIO
PAG43	AP_GPB18	3V3	NNFWE0	S	GPIO	N	Generic GPIO
PAH42	AP_GPC25	3V3	NSWAIT	S	GPIO	PU	Generic GPIO
PAH43	AP_GPE31	3V3	NSWE	S	GPIO	PU	Generic GPIO

## HDMI

Table 12. HDMI

BALL LOC	BALL Name	Power	Default	I/O Type	I/O	PU/PD	Function
PA29	AP_HDMI_CEC	3V3	SA3	S	GPIO	N	HDMI Consumer Electronics Control
PA30	AP_HDMI_TX2N	1V8	HDMI_TXN2	S	O	N	HDMI Transmit Channel 1 Negative
PA31	AP_HDMI_TX1N	1V8	HDMI_TXN1	S	O	N	HDMI Transmit Channel 0 Negative
PA32	AP_HDMI_TX0N	1V8	HDMI_TXN0	S	O	N	HDMI Transmit Channel 2 Negative
PA33	AP_HDMI_TXCN	1V8	HDMI_TXNCLK	S	O	N	HDMI Transmit Negative Clock
PB29	AP_HDMI_HPD	3V3	HDMI_HOT5V	S	I	N	HDMI Hot 5V
PB30	AP_HDMI_TX2P	1V8	HDMI_TXP2	S	O	N	HDMI Transmit Channel 1 Positive
PB31	AP_HDMI_TX1P	1V8	HDMI_TXP1	S	O	N	HDMI Transmit Channel 0 Positive
PB32	AP_HDMI_TX0P	1V8	HDMI_TXP0	S	O	N	HDMI Transmit Channel 2 Positive
PB33	AP_HDMI_TXCP	1V8	HDMI_TXPCLK	S	O	N	HDMI Transmit Positive Clock

## HSIC

Table 13. HSIC

BALL LOC	BALL Name	Power	Default	I/O Type	I/O	PU/PD	Function
PA38	AP_HSIC_STROBE	1V2	USBHSIC_STROBE	S	IO	N	HSIC Strobe
PB38	AP_HSIC_DATA	1V2	USBHSIC_DATA	S	IO	N	HSIC Data

## I<sup>2</sup>C

Table 14. I<sup>2</sup>C

BALL LOC	BALL Name	Power	Default	I/O Type	I/O	PU/PD	Function
PAK8	AP_GPD6_SCL	3V3	SCL2	S	GPIO	N	I2C SCL
PAK9	AP_GPD4_SCL1	3V3	SCL1	S	GPIO	N	I2C SCL 1
PAK10	AP_GPD2_SCL0	3V3	SCL0	S	GPIO	N	I2C SCL 0
PAK11	AP_GPA23_HDMI_I2C_SCL	3V3	DISD22	S	GPIO	N	HDMI I2C SCL
PAL8	AP_GPD7_SDA	3V3	SDA2	S	GPIO	N	I2C SDA
PAL9	AP_GPD5_SDA1	3V3	SDA1	S	GPIO	N	I2C SDA 1

BALL LOC	BALL Name	Power	Default	I/O Type	I/O	PU/PD	Function
PAL10	AP_GPD3_SDA0	3V3	SDA0	S	GPIO	N	I2C SDA 0
PAL11	AP_GPA24_HDMI_I2C_SDA	3V3	DISD23	S	GPIO	N	HDMI I2C SDA

## I<sup>2</sup>S

Table 15. I<sup>2</sup>S

BALL LOC	BALL Name	Power	Default	I/O Type	I/O	PU/PD	Function
PAK1	AP_I2S0_DOUT	3V3	I2SDOUT0	S	GPIO	N	I2S 0 Data Out
PAK2	AP_I2S0_BCLK	3V3	I2SBCLK0	S	GPIO	N	I2S 0 Bit Clock
PAK25	AP_GPB0_VID1_1_I2SLRCK1	3V3	VID1_1	S	GPIO	N	I2S 1 Left Right Clock
PAK26	AP_GPA28_I2SMCLK1	3V3	VICLK1	S	GPIO	N	I2S 1 Master Clock
PAK27	AP_GPA30_VID1_0_I2SBCLK1	3V3	VID1_0	S	GPIO	N	I2S 1 Bit Clock
PAL1	AP_I2S0_DIN	3V3	I2SDIN0	S	GPIO	N	I2S 0 Data In
PAL2	AP_I2S0_MCLK	3V3	I2SMCLK0	S	GPIO	N	I2S 0 Master Clock
PAL26	AP_GPB9_I2SDIN1	3V3	VID1_6	S	GPIO	N	I2S 1 Data In
PAL27	AP_GPB6_VID1_4_I2SDOUT1	3V3	VID1_4	S	GPIO	N	I2S 1 Data Out
PAJ1	AP_I2S0_LRCLK	3V3	I2SLRCLK0	S	GPIO	N	I2S 0 Left Right Clock

## JTAG

Table 16. JTAG

BALL LOC	BALL Name	Power	Default	I/O Type	I/O	PU/PD	Function
PAC1	AP_TCK	3V3	TCLK	S	GPIO	PD	JTAG TCK
PAC2	AP_TMS	3V3	TMS	S	GPIO	PU	JTAG TMS
PAD1	AP_TDO	3V3	TDO	S	GPIO	N	JTAG TDO
PAD2	AP_TDI	3V3	TDI	S	GPIO	PU	JTAG TDI
PAE1	AP_NTRST	3V3	NTRST	S	GPIO	PU	JTAG NTRST

## KEY

Table 17. Key

BALL LOC	BALL Name	Power	Default	I/O Type	I/O	PU/PD	Function
PAE2	AP_AGP2_RTC_INT_N	3V3	ALIVEGPIO2	S	IO	N	RTC Interrupt
PAF1	AP_PWRKEY	3V3	ALIVEGPIO0	S	IO	N	Power Key part of AliveGPIO
PAF2	AP_AGP1_HOMEKEY	3V3	ALIVEGPIO1	S	IO	N	Home Key part of AliveGPIO
PAG1	AP_NRESET	3V3	NRESET	S	I	N	Reset
PAG2	AP_GPA25_BACKKEY	3V3	DISVSYNC	S	GPIO	N	Back Key
PAH1	AP_GPA26_VOLUP	3V3	DISHSYNC	S	GPIO	N	Volume Up
PAH2	AP_GPA0_MENUKEY	3V3	DISCLK	S	GPIO	N	Menu Key
PAJ2	AP_GPA27_VOLDOWN	3V3	DISDE	S	GPIO	N	Volume Down

## LVDS

Table 18. LVDS

BALL LOC	BALL Name	Power	Default	I/O Type	I/O	PU/PD	Function
PA22	AP_LVDS_TN0	1V8	LVDS_TN0	S	IO	N	LVDS Transmit Channel 0 Negative
PA23	AP_LVDS_TN1	1V8	LVDS_TN1	S	IO	N	LVDS Transmit Channel 1 Negative
PA24	AP_LVDS_TN2	1V8	LVDS_TN2	S	IO	N	LVDS Transmit Channel 2 Negative
PA25	AP_LVDS_TNCLK	1V8	LVDS_TNCLK	S	IO	N	LVDS Transmit Negative Clock

BALL LOC	BALL Name	Power	Default	I/O Type	I/O	PU/PD	Function
PA26	AP_LVDS_TN3	1V8	LVDS_TN3	S	IO	N	LVDS Transmit Channel 3 Negative
PA27	AP_LVDS_TN4	1V8	LVDS_TN4	S	IO	N	LVDS Transmit Channel 4 Negative
PB22	AP_LVDS_TP0	1V8	LVDS_TP0	S	IO	N	LVDS Transmit Channel 0 Positive
PB23	AP_LVDS_TP1	1V8	LVDS_TP1	S	IO	N	LVDS Transmit Channel 1 Positive
PB24	AP_LVDS_TP2	1V8	LVDS_TP2	S	IO	N	LVDS Transmit Channel 2 Positive
PB25	AP_LVDS_TPCLK	1V8	LVDS_TPCLK	S	IO	N	LVDS Transmit Positive Clock
PB26	AP_LVDS_TP3	1V8	LVDS_TP3	S	IO	N	LVDS Transmit Channel 3 Positive
PB27	AP_LVDS_TP4	1V8	LVDS_TP4	S	IO	N	LVDS Transmit Channel 4 Positive

## MISCELLANEOUS

Table 19. Miscellaneous

BALL LOC	BALL Name	Power	Default	I/O Type	I/O	PU/PD	Function
PAK19	AP_NBATTFF	3V3	AP_NBATTFF	-	NA	-	Battery
PAK20	AP_GPE2	3V3	VID0_6	S	GPIO	N	Miscellaneous
PAK21	AP_GPE1	3V3	VID0_5	S	GPIO	N	Miscellaneous
PAK37	AP_GPB14	3V3	RNB0	S	GPIO	N	Miscellaneous
PAL19	AP_VDDPWON	3V3	VDDPWON	S	O	N	VDD Power On
PAL20	AP_GPE3	3V3	VID0_7	S	GPIO	N	Miscellaneous
PAL21	AP_GPE0	3V3	VID0_4	S	GPIO	N	Miscellaneous
PAL25	AP_GPD31	3V3	VID0_3	S	GPIO	N	Miscellaneous
PAL37	AP_GPB16	3V3	NNFOE0	S	GPIO	N	Miscellaneous

## POWER

Table 20. Power

BALL LOC	BALL Name	Power	Default	I/O Type	I/O	PU/PD	Function
PAK17	VCC3P3_SYS	3V3	-	NA	3V3	-	DCDC3, VCC 3V3 Power
PAK18	VCC3P3_SYS	3V3	-	NA	3V3	-	DCDC3, VCC 3V3 Power
PAL17	VCC3P3_SYS	3V3	-	NA	3V3	-	DCDC3, VCC 3V3 Power
PAL18	VCC3P3_SYS	3V3	-	NA	3V3	-	DCDC3, VCC 3V3 Power
PD42	VCC5P0_OTGVBUS	-	-	NA	5V0	-	USB2.0 OTG BUS Power
PD43	VCC5P0_OTGVBUS	-	-	NA	5V0	-	USB2.0 OTG BUS Power
PE42	VCC2P8 LDO7	0.9-3.5	-	NA	2V8	-	2V8 LDO, 25mV Step, 200mA Max
PE43	VCC2P8 LDO7	0.9-3.5	-	NA	2V8	-	2V8 LDO, 25mV Step, 200mA Max
PF42	VCC2P8 LDO7	0.9-3.5	-	NA	2V8	-	2V8 LDO, 25mV Step, 200mA Max
PH42	VCC LDO5	0.6-3.5	-	NA		-	User Controlled LDO, 0.6-3.5V, 25mV Step, 300mA Max
PH43	VCC LDO5	0.6-3.5	-	NA		-	User Controlled LDO, 0.6-3.5V, 25mV Step, 300mA Max
PJ42	VCC LDO5	0.6-3.5	-	NA		-	User Controlled LDO, 0.6-3.5V, 25mV Step, 300mA Max
PJ43	VCC LDO2	0.9-3.5	-	NA		-	User Controlled LDO, 0.9-3.5V, 25mV Step, 300mA Max
PK42	VCC LDO2	0.9-3.5	-	NA		-	User Controlled LDO, 0.9-3.5V, 25mV Step, 300mA Max
PK43	VCC LDO2	0.9-3.5	-	NA		-	User Controlled LDO, 0.9-3.5V, 25mV Step, 300mA Max
PM42	VCC LDO1	0.9-3.5	-	NA		-	User Controlled LDO, 0.9-3.5V, 25mV Step, 300mA Max
PM43	VCC LDO1	0.9-3.5	-	NA		-	User Controlled LDO, 0.9-3.5V, 25mV Step, 300mA Max
PN42	VCC LDO1	0.9-3.5	-	NA		-	User Controlled LDO, 0.9-3.5V, 25mV Step, 300mA Max
PP42	VCC1P2 LDO10	0.9-3.5	-	NA	1V2	-	1V2 LDO, 25mV Step, 200mA Max
PR42	VCC1P2 LDO10	0.9-3.5	-	NA	1V2	-	1V2 LDO, 25mV Step, 200mA Max
PT1	VCC1P8 LDO4	0.9-3.5	-	NA	1V8	-	1V8 LDO, 25mV Step, 300mA Max
PR43	VCC1P2 LDO10	0.9-3.5	-	NA	1V2	-	1V2 LDO, 25mV Step, 200mA Max
PT42	VCC LDO9	0.9-3.5	-	NA		-	User Controlled LDO, 0.9-3.5V, 25mV Step, 200mA Max
PU1	VCC1P8 LDO4	0.9-3.5	-	NA	1V8	-	1V8 LDO, 25mV Step, 300mA Max

BALL LOC	BALL Name	Power	Default	I/O Type	I/O	PU/PD	Function
PU42	VCC LDO9	0.9-3.5	-	NA		-	User Controlled LDO, 0.9-3.5V, 25mV Step, 200mA Max
PU43	VCC LDO9	0.9-3.5	-	NA		-	User Controlled LDO, 0.9-3.5V, 25mV Step, 200mA Max
PV1	VCC1P8 LDO4	0.9-3.5	-	NA	1V8	-	1V8 LDO, 25mV Step, 300mA Max
PV42	VBAT_MAIN	VBAT	-	NA		-	Main Power Supply for Module
PV43	VBAT_MAIN	VBAT	-	NA		-	Main Power Supply for Module
PW42	VBAT_MAIN	VBAT	-	NA		-	Main Power Supply for Module
PW43	VBAT_MAIN	VBAT	-	NA		-	Main Power Supply for Module
PY42	VBAT_MAIN	VBAT	-	NA		-	Main Power Supply for Module
PY43	VBAT_MAIN	VBAT	-	NA		-	Main Power Supply for Module
PAA42	VBAT_MAIN	VBAT	-	NA		-	Main Power Supply for Module
PAA43	VBAT_MAIN	VBAT	-	NA		-	Main Power Supply for Module
PAB42	VBAT_MAIN	VBAT	-	NA		-	Main Power Supply for Module
PAB43	VBAT_MAIN	VBAT	-	NA		-	Main Power Supply for Module
PAD42	VCC3V3 LDO8	0.9-3.5	-	NA	3V3	-	User Controlled LDO, 0.9-3.5V, 25mV Step, 200mA Max
PAD43	VCC3V3 LDO8	0.9-3.5	-	NA	3V3	-	User Controlled LDO, 0.9-3.5V, 25mV Step, 200mA Max
PAE43	VCC3V3 LDO8	0.9-3.5	-	NA	3V3	-	User Controlled LDO, 0.9-3.5V, 25mV Step, 200mA Max

## PWM

Table 21. PWM

BALL LOC	BALL Name	Power	Default	I/O Type	I/O	PU/PD	Function
PAK7	AP_GPC14_PWM2	3V3	SA14	S	GPIO	N	PWM 2
PAL7	AP_GPD1_PWM0	3V3	PWM0	S	GPIO	N	PWM 0

## SD/MMC

Table 22. SD/MMC

BALL LOC	BALL Name	Power	Default	I/O Type	I/O	PU/PD	Function
PAK28	AP_SD0_CMD	3V3	SDCMD0	S	GPIO	N	SD Command
PAK29	AP_SD0_D1	3V3	SDDAT0_1	S	GPIO	N	SD Data 1
PAK30	AP_SD0_CLK	3V3	SDCLK0	S	GPIO	N	SD Clock
PAL28	AP_SD0_D3	3V3	SDDAT0_3	S	GPIO	N	SD Data 3
PAL29	AP_SD0_D2	3V3	SDDAT0_2	S	GPIO	N	SD Data 2
PAL30	AP_SD0_D0	3V3	SDDAT0_0	S	GPIO	N	SD Data 0

## SPI

Table 23. SPI

BALL LOC	BALL Name	Power	Default	I/O Type	I/O	PU/PD	Function
PAK3	AP_GPC11_SPI2_MISO	3V3	SA11	S	GPIO	N	SPI 2 Receive Data
PAK4	AP_GPC9_SPI2_CLK	3V3	SA9	S	GPIO	N	SPI 2 Clock
PAK5	AP_SPI0_MISO	3V3	SPIRXD0	S	GPIO	N	SPI 0 Receive Data
PAK6	AP_SPI0_CLK	3V3	SPICLK0	S	GPIO	N	SPI 0 Clock
PAL3	AP_GPC12_SPI2_MOSI	3V3	SA12	S	GPIO	N	SPI 2 Transmit Data
PAL4	AP_GPC10_SPI2_CS	3V3	SA10	S	GPIO	PU	SPI 2 Frame
PAL5	AP_SPI0_MOSI	3V3	SPITXD0	S	GPIO	N	SPI 0 Transmit Data
PAL6	AP_SPI0_CS	3V3	SPIFRM0	S	GPIO	N	SPI 0 Frame

## UART

Table 24. UART

BALL LOC	BALL Name	Power	Default	I/O Type	I/O	PU/PD	Function
PAK22	AP_UARTTX3	3V3	UARTTXD3	S	GPIO	N	UART Transmit Data 3
PAK23	AP_UARTTX4	3V3	SD13	S	GPIO	N	UART Transmit Data 4
PAK24	AP_UARTTX5	3V3	SD15	S	GPIO	N	UART Transmit Data 5
PAL22	AP_UARTRX3	3V3	UARTRXD3	S	GPIO	N	UART Receive Data 3
PAL23	AP_UARTRX4	3V3	SD12	S	GPIO	N	UART Receive Data 4
PAL24	AP_UARTRX5	3V3	SD14	S	GPIO	N	UART Receive Data 5

## USB HOST/USB OTG

Table 25. USB Host/USB OTG

BALL LOC	BALL Name	Power	Default	I/O Type	I/O	PU/PD	Function
PA35	AP_OTG_DM	3V3	USB2.0OTG_DM	S	IO	N	USB OTG Data Minus
PA36	AP_USBH_DM	3V3	USB2.0HOST_DM	S	IO	N	USB HOST Data Plus
PB35	AP_OTG_DP	3V3	USB2.0OTG_DP	S	IO	N	USB OTG Data Plus
PB36	AP_USBH_DP	3V3	USB2.0HOST_DP	S	IO	N	USB HOST Data Minus
PB37	AP_OTG_ID	-	USB2.0OTG_ID	S	IO	N	USB HOST ID

## ZIGBEE

Table 26. ZigBee

BALL LOC	BALL Name	Power	Default	I/O Type	I/O	PU/PD	Function
PAK12	ZB_JTMS	3V3	-	-	-	-	ZIGBEE JTAG TMS
PAK13	ZB_JTCK	3V3	-	-	-	-	ZIGBEE JTAG TCK
PAK14	ZB_PC0	3V3	-	-	-	-	ZIGBEE Control
PAK15	ZB_PA4	3V3	-	-	-	-	ZIGBEE Control
PAL12	ZB_JTDI	3V3	-	-	-	-	ZIGBEE JTAG TDI
PAL13	ZB_JTDO	3V3	-	-	-	-	ZIGBEE JTAG TDO
PAL14	ZB_RSTn	3V3	SA8	S	GPIO	N	ZIGBEE Reset
PAL15	ZB_PA5	3V3	NSCS1	S	GPIO	PU	ZIGBEE Control

# ARTIK 710 MODULE GPIO ALTERNATE FUNCTIONS

A number of the GPIOs can be programmed to have alternate functions beyond their default behavior using the GPIO API provided in the SW development environment. [Table 27](#), [Table 28](#), [Table 29](#) and

[Table 30](#) provide the alternate functions of all the GPIOs that are available on the PADS of the ARTIK 710 Module that can be user programmed.

Table 27. GPIO Alternate Functions TOP PART

GPIO Alternate Functions TOP PART								
BALL LOC	Name	Default Function	I/O	Function 0	Function 1	Function 2	Function 3	Group
PA1	GMAC_TXEN	GMAC_TXEN	GPIO	GPIOE11	GMAC_TXEN	-	-	GMAC
PA2	GMAC_TXD1	GMAC_TXD1	GPIO	GPIOE8	GMAC_TXD1	-	-	GMAC
PA3	GMAC_TXD3	GMAC_TXD3	GPIO	GPIOE10	GMAC_TXD3	-	-	GMAC
PA5	GMAC_GTXCLK	GMAC_GTXCLK	GPIO	GPIOE24	GMAC_GTXCLK	-	-	GMAC
PA6	GMAC_RXDV	GMAC_RXDV	GPIO	GPIOE19	GMAC_RXDV	SPITXD1	-	GMAC
PA7	GMAC_RXD2	GMAC_RXD2	GPIO	GPIOE16	GMAC_RXD2	-	-	GMAC
PA8	GMAC_RXD0	GMAC_RXD0	GPIO	GPIOE14	GMAC_RXD0	SPICLK1	-	GMAC
PA29	AP_HDMI_CEC	SA3	GPIO	SA3	GPIOC3	HDMI_CEC	SDnRST0	HDMI
PA37	AP_GPA13	DISD12	GPIO	GPIOA13	DISD12	-	-	GPIO
PA39	AP_GPA14	DISD13	GPIO	GPIOA14	DISD13	-	-	GPIO
PA40	AP_GPA9	DISD8	GPIO	GPIOA9	DISD8	-	-	GPIO
PA41	AP_GPA15	DISD14	GPIO	GPIOA15	DISD14	-	-	GPIO
PA42	AP_GPA12	DISD11	GPIO	GPIOA12	DISD11	-	-	GPIO
PB2	GMAC_TXD0	GMAC_TXD0	GPIO	GPIOE7	GMAC_TXD0	VIVSYNC1	-	GMAC
PB3	GMAC_TXD2	GMAC_TXD2	GPIO	GPIOE9	GMAC_TXD2	-	-	GMAC
PB4	GMAC_MDC	GMAC_MDC	GPIO	GPIOE20	GMAC_MDC	-	-	GMAC
PB5	GMAC_RXCLK	GMAC_RXCLK	GPIO	GPIOE18	GMAC_RXCLK	SPIRXD1	-	GMAC
PB6	GMAC_RXD3	GMAC_RXD3	GPIO	GPIOE17	GMAC_RXD3	-	-	GMAC
PB7	GMAC_RXD1	GMAC_RXD1	GPIO	GPIOE15	GMAC_RXD1	SPIFRM1	-	GMAC
PB8	GMAC_MDIO	GMAC_MDIO	GPIO	GPIOE21	GMAC_MDIO	-	-	GMAC
PB39	AP_GPA4	DISD3	GPIO	GPIOA4	DISD3	-	-	GPIO
PB40	AP_GPA5	DISD4	GPIO	GPIOA5	DISD4	-	-	GPIO
PB41	AP_GPA16	DISD15	GPIO	GPIOA16	DISD15	-	-	GPIO
PB42	AP_GPA11	DISD10	GPIO	GPIOA11	DISD10	-	-	GPIO

Table 28. GPIO Alternate Functions BOTTOM PART

GPIO Alternate Functions BOTTOM PART								
BALL LOC	Name	Default Function	I/O	Function 0	Function 1	Function 2	Function 3	Group
PAK1	AP_I2S0_DOUT	I2SDOUT0	GPIO	GPIOD9	I2SDOUT0	AC97_DOUT	-	I2S0
PAK2	AP_I2S0_BCLK	I2SBCLK0	GPIO	GPIOD10	I2SBCLK0	AC97_BCLK	-	I2S0
PAK3	AP_GPC11_SPI2_MISO	SA11	GPIO	SA11	GPIOC11	SPIRXD2	USB2.0OTG_DrvVBUS	SPI2
PAK4	AP_GPC9_SPI2_CLK	SA9	GPIO	SA9	GPIOC9	SPICLK2	PDMStrobe	SPI2
PAK5	AP_SPI0_MISO	SPIRXD0	GPIO	GPIOD0	SPIRXD0	PWM3	-	SPI0
PAK6	AP_SPI0_CLK	SPICLK0	GPIO	GPIOC29	SPICLK0	-	-	SPI0
PAK7	AP_GPC14_PWM2	SA14	GPIO	SA14	GPIOC14	PWM2	VICLK2	PWM
PAK8	AP_GPD6_SCL	SCL2	GPIO	GPIOD6	SCL2	-	-	I2C
PAK9	AP_GPD4_SCL1	SCL1	GPIO	GPIOD4	SCL1	-	-	I2C
PAK10	AP_GPD2_SCL0	SCL0	GPIO	GPIOD2	SCL0	ISO7816	-	I2C
PAK11	AP_GPA23_HDMI_I2C_SCL	DISD22	GPIO	GPIOA23	DISD22	-	-	I2C
PAK20	AP_GPE2	VID0_6	GPIO	GPIOE2	VID0_6	TSIDATA1_6	-	MISC
PAK21	AP_GPE1	VID0_5	GPIO	GPIOE1	VID0_5	TSIDATA1_5	-	MISC
PAK22	AP_UARTTX3	UARTTXD3	GPIO	GPIOD21	UARTTXD3	-	SDnCD1	UART
PAK23	AP_UARTTX4	SD13	GPIO	SD13	GPIOB29	TSIDATA0_5	UARTTXD4	UART
PAK24	AP_UARTTX5	SD15	GPIO	SD15	GPIOB31	TSIDATA0_7	UARTTXD5	UART
PAK25	AP_GPB0_VID1_1_I2SLRCK1	VID1_1	GPIO	GPIOB0	VID1_1	SDEX1	I2SLRCLK1	I2S1
PAK26	AP_GPA28_I2SMCLK1	VICLK1	GPIO	GPIOA28	VICLK1	I2SMCLK2	I2SMCLK1	I2S1
PAK27	AP_GPA30_VID1_0_I2SBCLK1	VID1_0	GPIO	GPIOA30	VID1_0	SDEX0	I2SBCLK1	I2S1
PAK28	AP_SD0_CMD	SDCMD0	GPIO	GPIOA31	SDCMD0	-	-	SD/MMC
PAK29	AP_SD0_D1	SDDAT0_1	GPIO	GPIOB3	SDDAT0_1	-	-	SD/MMC
PAK30	AP_SD0_CLK	SDCLK0	GPIO	GPIOA29	SDCLK0	-	-	SD/MMC
PAK32	AP_GPB13_SD0_BOOT	SD0	GPIO	SD0	GPIOB13	-	-	BOOTING
PAK33	AP_GPC17	SA17	GPIO	SA17	GPIOC17	TSIDP0	VID2_0	GPIO
PAK34	AP_GPC0	SA0	GPIO	SA0	GPIOC0	TSERR0	-	GPIO
PAK35	AP_GPC26	RDNWR	GPIO	RDNWR	GPIOC26	PDMDATA0	-	GPIO
PAK36	AP_GPB8	VID1_5	GPIO	GPIOB8	VID1_5	SDEX5	I2SDOUT2	GPIO
PAK37	AP_GPB14	RNB0	GPIO	RnB0	RnB1	GPIOB14	-	MISC
PAK38	AP_GPA20	DISD19	GPIO	GPIOA20	DISD19	-	-	GPIO
PAK39	AP_GPA18	DISD17	GPIO	GPIOA18	DISD17	-	-	GPIO
PAK40	AP_GPA21	DISD20	GPIO	GPIOA21	DISD20	-	-	GPIO
PAK41	AP_GPA10	DISD9	GPIO	GPIOA10	DISD9	-	-	GPIO
PAK42	AP_GPA6	DISD5	GPIO	GPIOA6	DISD5	-	-	GPIO
PAL1	AP_I2S0_DIN	I2SDIN0	GPIO	GPIOD11	I2SDIN0	AC97_DIN	-	I2S0
PAL2	AP_I2S0_MCLK	I2SMCLK0	GPIO	GPIOD13	I2SMCLK0	AC97_nRST	-	I2S0
PAL3	AP_GPC12_SPI2_MOSI	SA12	GPIO	SA12	GPIOC12	SPITXD2	SDnRST2	SPI2
PAL4	AP_GPC10_SPI2_CS	SA10	GPIO	SA10	GPIOC10	SPIFRM2	-	SPI2
PAL5	AP_SPI0_MOSI	SPITXD0	GPIO	GPIOC31	SPITXD0	-	-	SPI0
PAL6	AP_SPI0_CS	SPIFRM0	GPIO	GPIOC30	SPIFRM0	-	-	SPI0
PAL7	AP_GPD1_PWM0	PWM0	GPIO	GPIOD1	PWM0	SA25	-	PWM
PAL8	AP_GPD7_SDA	SDA2	GPIO	GPIOD7	SDA2	-	-	I2C
PAL9	AP_GPD5_SDA1	SDA1	GPIO	GPIOD5	SDA1	-	-	I2C
PAL10	AP_GPD3_SDA0	SDA0	GPIO	GPIOD3	SDA0	ISO7816	-	I2C
PAL11	AP_GPA24_HDMI_I2C_SDA	DISD23	GPIO	GPIOA24	DISD23	-	-	I2C
PAL14	ZB_RSTN	SA8	GPIO	SA8	GPIOC8	UARTnDTR1	SDnINT1	ZIGBEE
PAL15	ZB_PA5	NSCS1	GPIO	GPIOC28	NSCS1	UARTnRI1	-	ZIGBEE
PAL20	AP_GPE3	VID0_7	GPIO	GPIOE3	VID0_7	TSIDATA1_7	-	MISC

GPIO Alternate Functions BOTTOM PART								
BALL LOC	Name	Default Function	I/O	Function 0	Function 1	Function 2	Function 3	Group
PAL21	AP_GPE0	VID0_4	GPIO	GPIOE0	VID0_4	TSIDATA1_4	-	MISC
PAL22	AP_UARTRX3	UARTRXD3	GPIO	GIOD17	UARTRXD3	-	-	UART
PAL23	AP_UARTRX4	SD12	GPIO	SD12	GPIOB28	TSIDATA0_4	UARTRXD4	UART
PAL24	AP_UARTRX5	SD14	GPIO	SD14	GPIOB30	TSIDATA0_6	UARTRXD5	UART
PAL25	AP_GPD31	VID0_3	GPIO	GIOD31	VID0_3	TSIDATA1_3	-	MISC
PAL26	AP_GPB9_I2SDIN1	VID1_6	GPIO	GPIOB9	VID1_6	SDEX6	I2SDIN1	I2S1
PAL27	AP_GPB6 VID1_4_I2SDOUT 1	VID1_4	GPIO	GPIOB6	VID1_4	SDEX4	I2SDOUT1	I2S1
PAL28	AP_SD0_D3	SDDAT0_3	GPIO	GPIOB7	SDDAT0_3	-	-	SD/MMC
PAL29	AP_SD0_D2	SDDAT0_2	GPIO	GPIOB5	SDDAT0_2	-	-	SD/MMC
PAL30	AP_SD0_D0	SDDAT0_0	GPIO	GPIOB1	SDDAT0_0	-	-	SD/MMC
PAL31	AP_GPB4 VID1_3_BOOT	VID1_3	GPIO	GPIOB4	VID1_3	SDEX3	I2SLRCLK2	BOOTING
PAL32	AP_GPB15_SD1_BOOT	SD1	GPIO	SD1	GPIOB15	-	-	BOOTING
PAL33	AP_GPD8	SD8	GPIO	SD8	GPIOB24	TSIDATA0_0	-	GPIO
PAL34	AP_GPE30	NSOE	GPIO	NSOE	GPIOE30	-	-	GPIO
PAL35	AP_GPC27	NSDQM	GPIO	NSDQM	GPIOC27	PDMDATA1	-	GPIO
PAL36	AP_GPB22	SD6	GPIO	SD6	GPIOB22	-	-	GPIO
PAL37	AP_GPB16	NNFOE0	GPIO	NNFOE0	NNFOE1	GPIOB16	-	MISC
PAL38	AP_GPB23	SD7	GPIO	SD7	GPIOB23	-	-	GPIO
PAL39	AP_GPA22	DISD21	GPIO	GPIOA22	DISD21	-	-	GPIO
PAL40	AP_GPA19	DISD18	GPIO	GPIOA19	DISD18	-	-	GPIO
PAL41	AP_GPA17	DISD16	GPIO	GPIOA17	DISD16	-	-	GPIO
PAL42	AP_GPA3	DISD2	GPIO	GPIOA3	DISD2	-	-	GPIO

Table 29. GPIO Alternate Functions LEFT PART

GPIO Alternate Functions LEFT PART								
BALL LOC	Name	Default Function	I/O	Function 0	Function 1	Function 2	Function 3	Group
PAC1	AP_TCK	TCLK	GPIO	TCLK	GPIOE28	-	-	JTAG
PAC2	AP_TMS	TMS	GPIO	TMS	GPIOE26	-	-	JTAG
PAD1	AP_TDO	TDO	GPIO	TDO	GPIOE29	-	-	JTAG
PAD2	AP_TDI	TDI	GPIO	TDI	GPIOE27	-	-	JTAG
PAE1	AP_NTRST	NTRST	GPIO	NTRST	GPIOE25	-	-	JTAG
PAG2	AP_GPA25_BACKKEY	DISVSYNC	GPIO	GPIOA25	DISVSYNC	-	-	KEY
PAH1	AP_GPA26_VOLUP	DISHSYNC	GPIO	GPIOA26	DISHSYNC	-	-	KEY
PAH2	AP_GPA0_MENUKEY	DISCLK	GPIO	GPIOA0	DISCLK	-	-	KEY
PAJ1	AP_I2S0_LRCLK	I2SLRCLK0	GPIO	GPIOD12	I2SLRCLK0	AC97_SYNC	-	I2S0
PAJ2	AP_GPA27_VOLDOWN	DISDE	GPIO	GPIOA27	DISDE	-	-	KEY

Table 30. GPIO Alternate Functions RIGHT PART

GPIO Alternate Functions RIGHT PART								
BALL LOC	Name	Default Function	I/O	Function 0	Function 1	Function 2	Function 3	Group
PAG42	AP_GPB11	CLE0	GPIO	CLE0	CLE1	GPIOB11	-	GPIO
PAG43	AP_GPB18	NNFWE0	GPIO	NNFWE0	nNFWE1	GPIOB18	-	GPIO
PAH42	AP_GPC25	NSWAIT	GPIO	NSWAIT	GPIOC25	SPDIFTX	-	GPIO
PAH43	AP_GPE31	NSWE	GPIO	NSWE	GPIOE31	-	-	GPIO

## ARTIK 710 MODULE BOOTING SEQUENCE

The ARTIK 710 Module supports a variety of booting scenarios as depicted in [Table 31](#). [Table 32](#) describes the values of the PAD signals needed to initiate the various booting scenarios. When nothing is done, default booting will take place.

(AP\_GPB13\_SD0\_BOOT is High, AP\_GPB15\_SD1\_BOOT is Low and AP\_GPB4\_VID1\_3\_BOOT is High) In this case, the ARTIK 710 Module will try to boot from eMMC, if this fails, it will continue to initiate a boot from SD0 and if this fails, it will continue booting from the USB device. The other booting scenarios execute in a similar manner. Changing the PAD signals according to the values in [Table 32](#) will allow for different booting options to be executed. By default the ARTIK 710 Module will boot in a non-secure way.

Table 31. Booting Scenarios

Booting Scenario	Primary Booting Device	Secondary Booting Device	Tertiary Booting Device
1	Boot from eMMC	Boot from SD0	Boot from USB device
2	-	Boot from SD0	Boot from USB device
3	-	-	Boot from USB device

Table 32. Booting Options

Signal Name	Booting Scenario 1 (default)	Booting Scenario 2	Booting Scenario 3
AP_GPB13_SD0_BOOT	High	High	Low
AP_GPB15_SD1_BOOT	Low	Low	High
AP_GPB4_VID1_3_BOOT	High	Low	X

## ARTIK 710 MODULE POWER STATES

Figure 6 shows the Power Management state diagram. In this diagram the entry and WAKEUP conditions for each power down mode are given.

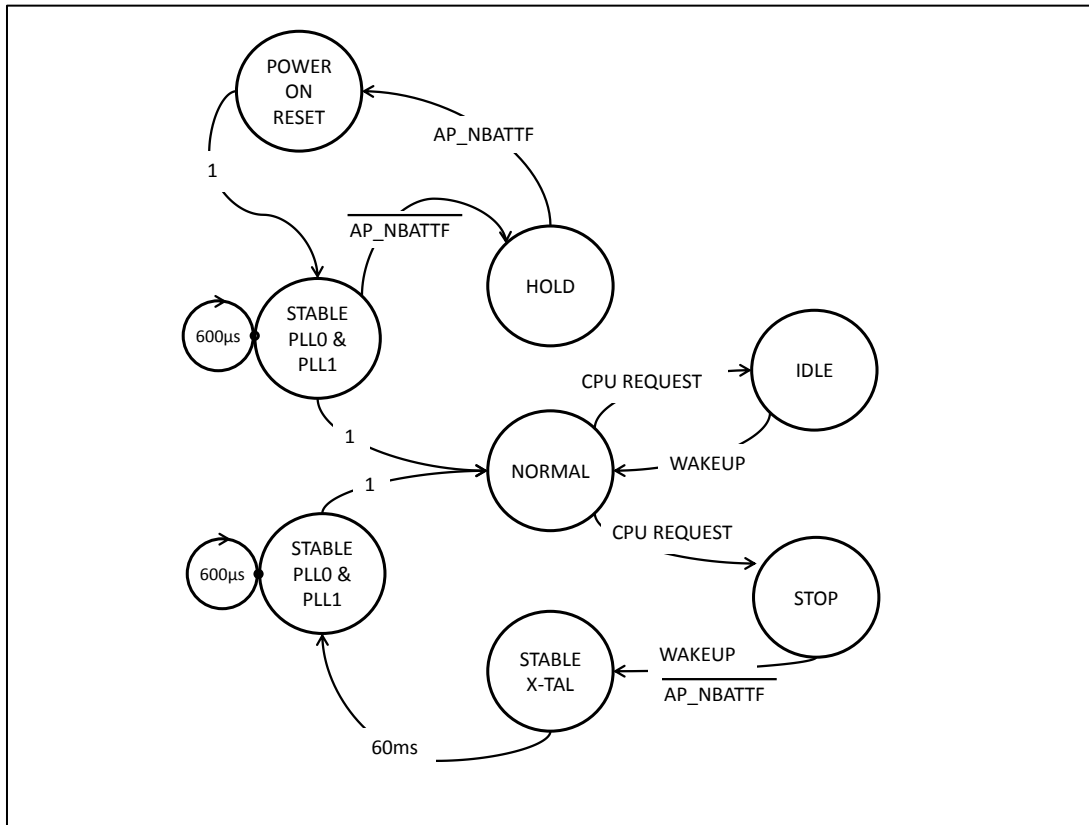

Figure 6. ARTIK 710 Module Power Management State Diagram

The following Modes of operation can be distinguished:

- NORMAL Mode
  - Everything is running, this is the normal mode of operation when applications are executed on the ARM cores
- IDLE Mode
  - CPU clocks are turned off
  - IDLE state can be initiated by CPU using Software API
  - The following WAKEUP sources can be used to return to NORMAL Mode:
- GPIO Interrupt, RTC Interrupt, AliveGPIO Interrupt (see BOT:[AP\_AGP2\_RTC\_INT\_N, AP\_PWRKEY, AP\_AGP1\_HOMEKEY]), External IRQ
- STOP Mode
  - PLLs are turned off, DRAM goes into self-refresh
  - STOP state can be initiated by CPU using Software API
  - Certain WAKEUP sources or the ARTIK 710 Module AP\_NBATTFF signal can be used to transition to NORMAL Mode
  - The following WAKEUP sources can be used to return to NORMAL Mode:
    - RTC Interrupt, AliveGPIO Interrupt

For more information on how to access discussed WAKEUP mechanisms like AliveGPIO interrupts, GPIO Interrupts, RTC Interrupts and External Interrupts, please refer to the Software User Guide.

## ARTIK 710 MODULE ANTENNA CONNECTIONS

Two antennas are required to use the full set of radio communication links on the ARTIK 710 Module. One supports the combination of Wi-Fi and BT, and the other is dedicated to 802.15.4 for ZigBee or Thread.

**Caution:** Do not apply power (enable) the radio chips before connecting antennas or damage to the chip may result.

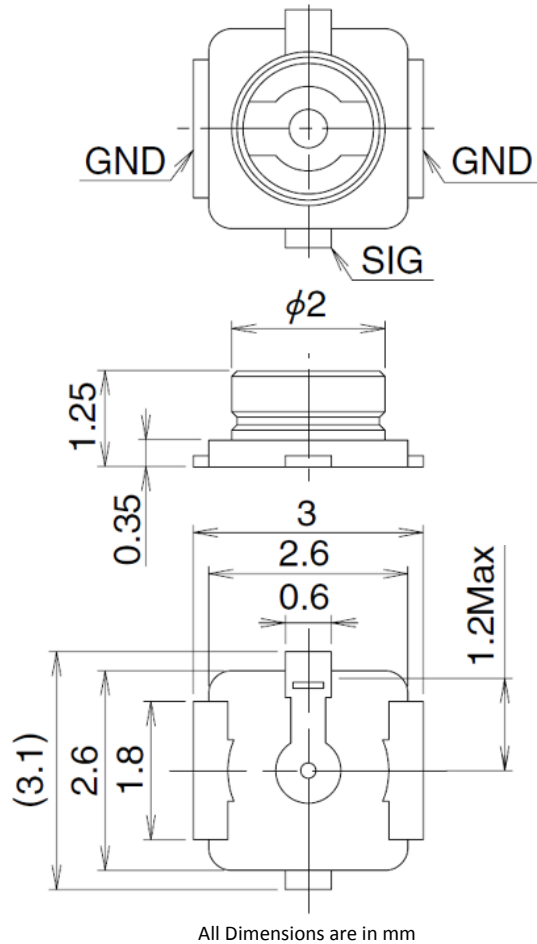

Figure 7. RF Connector for BT/Wi-Fi and ZigBee/Thread

The U.FL-R-SMT Hirose connector is used for both the BT/Wi-Fi and the 802.15.4 for ZigBee or Thread antenna connectors on the ARTIK 710 Module.

The mechanical size of the connector (receptacle) is described in [Figure 7](#). For suggestions on mating plug and more details on the connector, please contact Hirose Electric Co., LTD.

# ARTIK 710 MODULE ELECTRICAL SPECIFICATIONS

## ABSOLUTE MAXIMUM RATINGS

The ratings given in this section are associated only with stress. It does not imply any functional operation of the device. Exposure to the absolute-maximum rated conditions for long duration affects the reliability of the device.

Table 33. Absolute Maximum Ratings

Absolute Maximum Ratings					
Parameter	Symbol	Condition	Min	Max	Units
Main battery supply	VBAT_MAIN	-	-0.3	6.0	
DC input/output voltage	PA:[1,2,3,5,6,7,8,29,37,39,40,41,42] PB:[2,3,4,5,6,7,8,39,40,41,42] PAK:[1,2,3,4,5,6,7,8,9,10,11,20,21,22,23,24,25,26,27,28,29,30,31,32,33,34,35,36,37,38,39,40,41,42] PAL:[1,2,3,4,5,6,7,8,9,10,11,14,15,20,21,22,23,24,25,26,27,28,29,30,31,32,33,34,35,36,37,38,39,40,41,42] PAC:[1,2] PAD:[1,2] PAE:[1] PAG:[2,42,43] PAH:[1,2,42,43] PAJ:[1,2]	3.3V Buffer	-0.5	3.8	V
	PAK:[43] PAL:[43] PAJ:[42,43]	3.3V Input/output buffer	-0.5	3.8	
	PAK:[12,13,14,15] PAL:[12,13,14,15]	3.3V Input/output buffer	-0.3	3.6	
	PAF:[1]	-	-0.3	3.8	
	PAL:[19]	-	-0.3	6.3	
DC Input output current	PA:[1,2,3,5,6,7,8,29,37,39,40,41,42] PB:[2,3,4,5,6,7,8,39,40,41,42] PAK:[1,2,3,4,5,6,7,8,9,10,11,20,21,22,23,24,25,26,27,28,29,30,31,32,33,34,35,36,37,38,39,40,41,42] PAL:[1,2,3,4,5,6,7,8,9,10,11,14,15,20,21,22,23,24,25,26,27,28,29,30,31,32,33,34,35,36,37,38,39,40,41,42] PAC:[1,2] PAD:[1,2] PAE:[1] PAG:[2,42,43] PAH:[1,2,42,43] PAJ:[1,2]	-	-20	20	mA
Storage Temperature	T <sub>A</sub>	Commercial	-20	85	°C
	T <sub>A</sub>	Industrial	TBD	TBD	°C

## RECOMMENDED OPERATING CONDITIONS

The recommended operation of the ARTIK 710 Module is based on the operating conditions listed in [Table 34](#).

Table 34. Recommended Operating Conditions

Parameter	Symbol	Min	Typ	Max	Units
Main Battery Supply	VBAT_MAIN PV:[42,43],PW:[42,43],PY:[42,43],PAA:[42,43],PAB:[42,43]	3.7	4.2	5.0	V
Operating Temperature	Commercial	0	-	70	°C
	Industrial	TBD	-	TBD	°C

DC MODULE USE CASE CHARACTERISTICS

POWER SUPPLY REQUIREMENTS

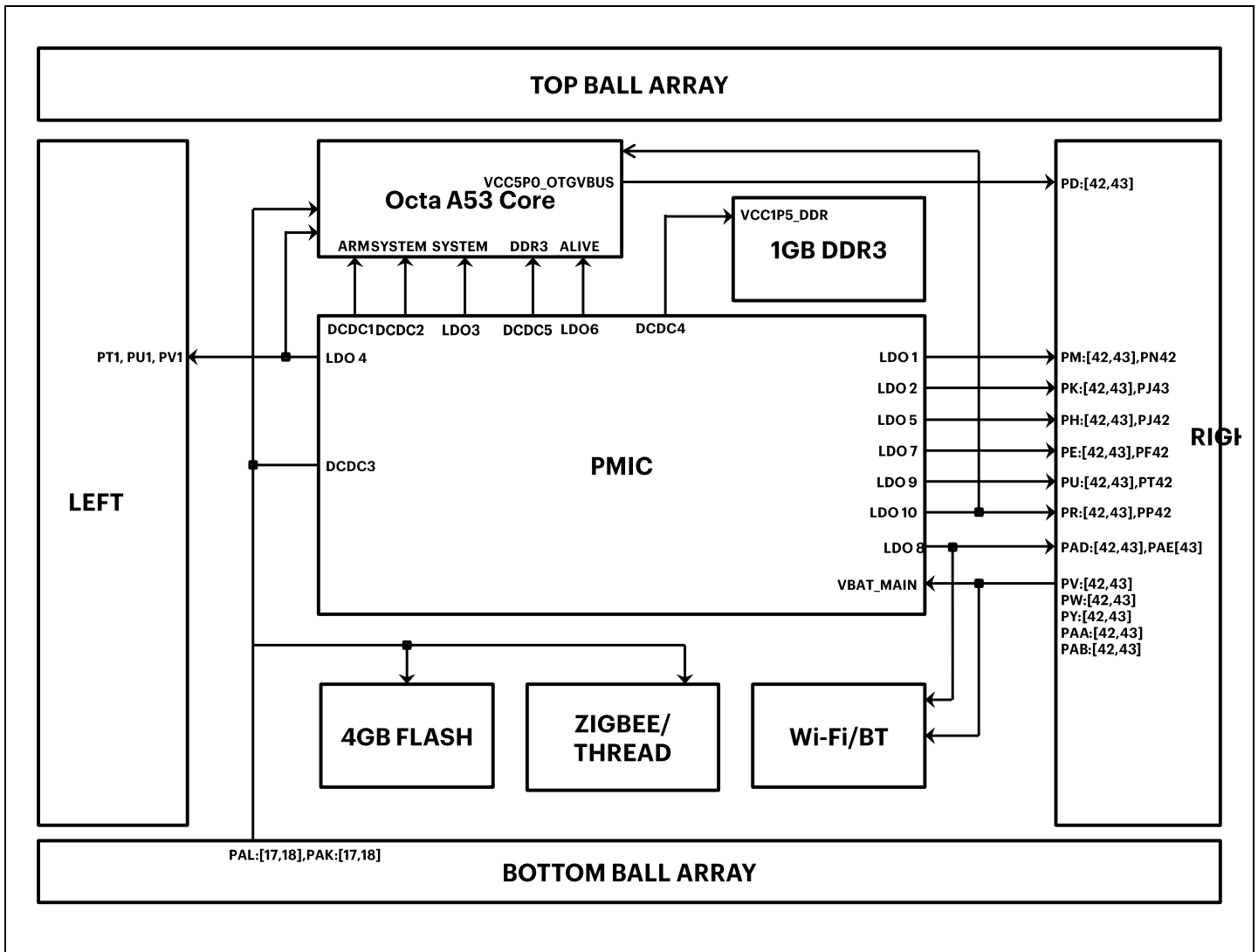

Figure 8. ARTIK 710 Module Power Distribution

The power management of the ARTIK 710 Module as described in [Figure 8](#) is controlled by the PMIC. This PMIC contains 5 high efficiency DC-DC converters and 10 LDO regulators. See [Table 35](#) and [Table 36](#) for details on voltage and amperage ranges and how they are used in the ARTIK 710 Module.

Table 35. DC-DC Converter Description

Buck	Powers	Header	Max Current [mA]	Range [V]	Default [V]
DCDC1	ARM	-	4000	0.60-3.50	1.30
DCDC2	ARM SoC	-	4000	0.60-3.50	1.20
DCDC3	FLASH, ZIGBEE, GPIO of ARM SoC	PAL:[17,18],PAK:[17,18]	1000	0.60-3.50	3.30
DCDC4	DDR3 Memory	-	2000	0.60-3.50	1.50
DCDC5	DDR3 Memory of ARM SoC	-	2000	0.60-3.50	1.50

Table 36. PMIC LDOs

LDO	Powers	Header	Current [mA]	Range [V]	Step [mV]	Default [V]
LDO1	User Controlled	PM:[42,43],PN42	300	0.90-3.50	25	-
LDO2	User Controlled	PK:[42,43],PJ43	300	0.90-3.50	25	-
LDO3	Powers SYSTEM of ARM SoC	-	300	0.90-3.50	25	1.80
LDO4	Powers ADC, USB of ARM SoC	PT1, PU1, PV1	300	0.90-3.50	25	1.80
LDO5	User Controlled	PH:[42,43],PJ42	300	0.60-3.50	25	-
LDO6	Powers 3.3V Alive Signal of ARM SoC	-	300	0.60-3.50	25	3.30
LDO7	User Available	PE:[42,43],PF42	200	0.90-3.50	25	2.80
LDO8	User Controlled	PAD:[42,43],PAE[43]	200	0.90-3.50	25	-
LDO9	User Controlled	PU:[42,43],PT42	200	0.90-3.50	25	-
LDO10	User Available	PR:[42,43],PP42	200	0.90-3.50	25	1.20

Table 37. AC/DC Characteristics LDO1, LDO2, LDO4

PM:[42,43], PN42, PK:[42,43], PJ43, PT1, PU1, PV1 Operating Conditions $V_{IN}=3.6V$ , $C_{OUT}=4.7\mu F$ , $T_A=25^\circ C$ unless otherwise specified						
Symbol	Parameter	Condition	Min	Typ	Max	Unit
$V_{IN}$	Input Voltage Range	-	3.70	4.20	5.00	V
$V_{OUT}$	Output Voltage Range	$50\mu A < I_{OUT} < I_{OUTMAX}$	0.90	-	3.50	V
	Voltage Setting Step Width	-	-	25	-	mV
$V_{ACCU}$	Output Voltage Accuracy	$V_{OUT} = \text{All Output Range}, I_{OUT}=1mA$	-1.50	-	1.50	%
$I_{OUTMAX}$	Output Current	-	-	-	300	mA
$I_{LIM}$	Limit Current	-	350	-	-	mA
$V_{DIFF}$	Dropout Voltage	$V_{OUT} \text{ Setting}=V_{IN}, I_{OUT}=I_{OUTMAX}$	-	-	0.20	V
$V_{LINE}$	Line Regulation	$2.7 < V_{IN} < 5.5V, I_{OUT}=1mA$	-	-	0.20	%/V
$V_{LOAD}$	Load Regulation	$100\mu A < I_{OUT} < I_{OUTMAX}$	-	-	30	mV
$V_{TR}$	Transient Response	$I_{OUT}=100\mu A > I_{OUTMAX}/2$	-	50	-	mV
RR	Ripple Rejection	$F=217 \sim 1kHz, I_{OUT}=I_{OUTMAX}/2, V_{DIFF} > 0.6V$	-	70	-	dB
$O_{NOISE}$	Output Noise	$I_{OUT}=I_{OUTMAX}/2, BW=10Hz-100kHz$	-	20	-	$\mu V_{rms}$
$I_{SS}$	Supply Current	$I_{OUT}=0mA$	-	100	-	$\mu A$
$I_{OFF}$	Standby Current	$I_{OUT}=0mA$	-	-	1	$\mu A$
$T_R$	Rising Time	$V_{OUT} \times 0.9, I_{OUT}=0mA$	-	-	500	$\mu s$
$T_F$	Falling Time	$V_{OUT} \times 0.1, I_{OUT}=0mA$	-	-	1	ms
$C_{OUT}$	Output Capacitor	-	-	4.7	-	$\mu F$

Table 38. AC/DC Characteristics LDO1, LDO2, LDO4 Eco Mode

PM:[42,43], PN42, PK:[42,43], PJ43, PT1, PU1, PV1 Operating Conditions $V_{IN}=3.6V$ , $C_{OUT}=4.7\mu F$ , $T_A=25^\circ C$ unless otherwise specified						
Symbol	Parameter	Condition	Min	Typ	Max	Unit
$V_{IN}$	Input Voltage Range	-	3.70	4.20	5.00	V
$V_{OUT}$	Output Voltage Range	$50\mu A < I_{OUT} < I_{OUTMAX}$	0.90	-	3.50	V
	Voltage Setting Step Width	-	-	25	-	mV
$V_{ACCU}$	Output Voltage Accuracy	$V_{OUT} = \text{All Output Range}, I_{OUT}=1mA$	-1.50	-	1.50	%
$I_{OUTMAX}$	Output Current	Eco Mode	-	-	10	mA
$I_{SS}$	Supply Current	-	-	1	1.5	$\mu A$

Table 39. AC/DC Characteristics LDO5

PH:[42,43], PJ42						
Operating Conditions $V_{IN}=3.6V$ , $C_{OUT}=1\mu F$ , $T_A=25^\circ C$ unless otherwise specified						
Symbol	Parameter	Condition	Min	Typ	Max	Unit
$V_{IN}$	Input Voltage Range	-	3.70	4.20	5.00	V
$V_{OUT}$	Output Voltage Range	$50\mu A < I_{OUT} < I_{OUTMAX}$	0.60	-	3.50	V
	Voltage Setting Step Width	-	-	25	-	mV
$V_{ACCU}$	Output Voltage Accuracy	$V_{OUT} = \text{All Output Range}, I_{OUT}=1mA$	-1.50	-	1.50	%
$I_{OUTMAX}$	Output Current	-	-	-	300	mA
$I_{LIM}$	Limit Current	-	350	-	-	mA
$V_{DIFF}$	Dropout Voltage	$V_{OUT} \text{ Setting}=V_{IN}, I_{OUT}=I_{OUTMAX}$	-	-	0.30	V
$V_{LINE}$	Line Regulation	$2.7 < V_{IN} < 5.5V, I_{OUT}=1mA$	-	-	0.20	%/V
$V_{LOAD}$	Load Regulation	$100\mu A < I_{OUT} < I_{OUTMAX}$	-	-	30	mV
$V_{TR}$	Transient Response	$I_{OUT}=100\mu A < I_{OUTMAX}/2$	-	40	-	mV
RR	Ripple Rejection	$F=217 \sim 1kHz, I_{OUT}=I_{OUTMAX}/2, V_{DIFF} > 0.6V$	-	70	-	dB
$O_{NOISE}$	Output Noise	$I_{OUT}=I_{OUTMAX}/2, BW=10Hz-100kHz$	-	100	-	$\mu V_{rms}$
$I_{SS}$	Supply Current	$I_{OUT}=0mA$	-	20	-	$\mu A$
$I_{OFF}$	Standby Current	$I_{OUT}=0mA$	-	-	1	$\mu A$
$T_R$	Rising Time	$V_{OUT} \times 0.9, I_{OUT}=0mA$	-	-	500	$\mu s$
$T_F$	Falling Time	$V_{OUT} \times 0.1, I_{OUT}=0mA$	-	-	500	$\mu s$
$C_{OUT}$	Output Capacitor	-	-	1.0	-	$\mu F$

Table 40. AC/DC Characteristics LDO5 Eco Mode

PH:[42,43], PJ42						
Operating Conditions $V_{IN}=3.6V$ , $C_{OUT}=1\mu F$ , $T_A=25^\circ C$ unless otherwise specified						
Symbol	Parameter	Condition	Min	Typ	Max	Unit
$V_{IN}$	Input Voltage Range	-	3.70	4.20	5.00	V
$V_{OUT}$	Output Voltage Range	$50\mu A < I_{OUT} < I_{OUTMAX}$	0.60	-	3.50	V
	Voltage Setting Step Width	-	-	25	-	mV
$V_{ACCU}$	Output Voltage Accuracy	$V_{OUT} = \text{All Output Range}, I_{OUT}=1mA$	-1.50	-	1.50	%
$I_{OUTMAX}$	Output Current	$V_{IN} > 2.7V$	-	-	10	mA
		$1.7 \leq V_{IN} < 2.7V$	-	-	5	mA
$I_{SS}$	Supply Current	$I_{OUT}=0mA$	-	1	1.5	$\mu A$

Table 41. AC/DC Characteristics LDO7, LDO8, LDO9, LDO10

PE:[42,43], PF42, PAD:[42,43], PAE[43], PU:[42,43], PT42, PR:[42,43], PP42 Operating Conditions $V_{IN}=3.6V$ , $C_{OUT}=1\mu F$ , $T_A=25^\circ C$ unless otherwise specified						
Symbol	Parameter	Condition	Min	Typ	Max	Unit
$V_{IN}$	Input Voltage Range	-	3.70	4.20	5.00	V
$V_{OUT}$	Output Voltage Range	$50\mu A < I_{OUT} < I_{OUTMAX}$	0.60	-	3.50	V
	Voltage Setting Step Width	-	-	25	-	mV
$V_{ACCU}$	Output Voltage Accuracy	$V_{OUT} = \text{All Output Range}, I_{OUT}=1mA$	-1.50	-	1.50	%
$I_{OUTMAX}$	Output Current	-	-	-	200	mA
$I_{LIM}$	Limit Current	-	250	-	-	mA
$V_{DIFF}$	Dropout Voltage	$V_{OUT} \text{ Setting} = V_{IN}, I_{OUT} = I_{OUTMAX}$	-	-	0.40	V
$V_{LINE}$	Line Regulation	$2.7 < V_{IN} < 5.5V, I_{OUT}=1mA$	-	-	0.20	%/V
$V_{LOAD}$	Load Regulation	$100\mu A < I_{OUT} < I_{OUTMAX}$	-	-	20	mV
$V_{TR}$	Transient Response	$I_{OUT}=100\mu A < I_{OUTMAX}/2$	-	30	-	mV
RR	Ripple Rejection	$F=217 \sim 1kHz, I_{OUT}=I_{OUTMAX}/2, V_{DIFF} > 0.6V$	-	70	-	dB
$O_{NOISE}$	Output Noise	$I_{OUT}=I_{OUTMAX}/2, BW=10Hz-100kHz, V_{OUT}=1.2V$	-	50	-	$\mu V_{rms}$
$I_{SS}$	Supply Current	$I_{OUT}=0mA$	-	20	-	$\mu A$
$I_{OFF}$	Standby Current	$I_{OUT}=0mA$	-	-	1	$\mu A$
$T_R$	Rising Time	$V_{OUT} \times 0.9, I_{OUT}=0mA$	-	-	500	$\mu s$
$T_F$	Falling Time	$V_{OUT} \times 0.1, I_{OUT}=0mA$	-	-	500	$\mu s$
$C_{OUT}$	Output Capacitor	-	-	1.0	-	$\mu F$

## ESD RATINGS

Table 42. ESD Ratings

Symbol	Min.	Max.	Units
ESD stress voltage Human Body Model	-	TBD	kV
ESD stress voltage Charged Device Model	-	TBD	V

Table 43. Shock and Vibration Ratings

Shock and Vibration		Range
Shock	Operating	TBD
	Non Operating	TBD
Vibration	Operating	TBD
	Non Operating	TBD

### DC ELECTRICAL CHARACTERISTICS

The DC characteristics for the GPIO pins of the ARTIK 710 Module are listed in [Table 44](#). Use the parameters from [Table 44](#) to determine maximum DC loading and to determine maximum transition times for a given load.

Table 44. I/O DC Electrical Characteristics GPIO

V<sub>DD</sub> = 3.3V, V<sub>ext</sub> = 3.0 to 3.6 V, T<sub>j</sub> = -40 to 125 °C (Junction Temperature), 3.30V Tolerant

GPIO BALL Coordinates	Parameter	Condition	Min	Typ	Max	Units		
PA:[1,2,3,5,6,7,8,29,37,39,40,41,42] PB:[2,3,4,5,6,7,8,39,40,41,42] PAK:[1,2,3,4,5,6,7,8,9,10,11,20,21,22,23,24,25,26,27,28,29,30,31,32,33,34,35,36,37,38,39,40,41,42] PAL:[1,2,3,4,5,6,7,8,9,10,11,20,21,22,23,24,25,26,27,28,29,30,31,32,33,34,35,36,37,38,39,40,41,42] PAC:[1,2] PAD:[1,2] PAE:[1] PAG:[2,42,43] PAH:[1,2,42,43] PAJ:[1,2]	V <sub>TOL</sub>	Tolerant external voltage	V <sub>DD</sub> Power Off & On		-	-	3.60	V
	V <sub>IH</sub>	High Level Input Voltage		2.31	-	3.60	V	
		CMOS Interface	-					
	V <sub>IL</sub>	Low Level Input Voltage		-0.3	-	0.70	V	
		CMOS Interface	V <sub>DD</sub> = 3.3V ± 10 %					
	ΔV	Hysteresis Voltage		0.15	-		V	
	I <sub>IH</sub>	High Level Input Current		-3	-	3	μA	
		Input Buffer	V <sub>IN</sub> = V <sub>DD</sub>					V <sub>DD</sub> Power On
								V <sub>DD</sub> Power Off & SNS = 0
	Input Buffer with pull-down	V <sub>IN</sub> = V <sub>DD</sub>	V <sub>DD</sub> = 3.3V ± 10 %	15	40	80		
	I <sub>IL</sub>	Low Level Input Current		-3	-	3	μA	
		Input Buffer	V <sub>IN</sub> = V <sub>SS</sub>					V <sub>DD</sub> Power On & Off
								V <sub>DD</sub> = 3.3V ± 10 %
	Input Buffer with pull-up	V <sub>IN</sub> = V <sub>SS</sub>	V <sub>DD</sub> = 3.3V ± 10 %	-15	-40	-110		
	V <sub>OH</sub>	Output High Voltage	I <sub>OH</sub> = -1.8mA, -3.6mA, -7.2mA, -10.8mA	2.64	-	3.30	V	
V <sub>OL</sub>	Output Low Voltage	I <sub>OH</sub> = -1.8mA, -3.6mA, -7.2mA, -10.8mA	0	-	0.66	V		
I <sub>OZ</sub>	Output Hi-Z current	-	-5	-	5	μA		
C <sub>IN</sub>	Input capacitance	Any input and bi-directional buffers	-	-	5	pF		
C <sub>OUT</sub>	Output capacitance	Any output buffer	-	-	5	pF		

Table 45. I/O DC Electrical Characteristics GPIO

ZIGBEE/THREAD BALL Coordinates	Parameter	Test Condition	Min	Typ	Max	Units
PAK:[12,13,14,15] PAL:[12,13,14,15]	Low Schmitt switching threshold	V <sub>SWIL</sub> Schmitt input threshold going from high to low	1.39	-	1.65	V
	High Schmitt switching threshold	V <sub>SWIH</sub> Schmitt input threshold going from low to high	2.05	-	2.64	V
	Input current for logic 0	I <sub>IL</sub>	-	-	-0.5	μA
	Input current for logic 1	I <sub>IH</sub>	-	-	+0.5	μA
	Input pull-up resistor value	R <sub>IPU</sub>	24	29	34	kΩ
	Input pull-down resistor value	R <sub>IPD</sub>	24	29	34	kΩ
	Output voltage for logic 0	V <sub>OL</sub> (I <sub>OL</sub> = 4mA for standard pads, 8mA for high current pads)	0	-	0.60	V
	Output voltage for logic 1	V <sub>OH</sub> (I <sub>OH</sub> = 4mA for standard pads, 8mA for high current pads)	2.71	-	3.30	V
	Output source current (standard current pad)	I <sub>OHS</sub>	-	-	4	mA
	Output sink current (standard current pad)	I <sub>OLS</sub>	-	-	4	mA
	Output source current high current pad: BOT:[66]	I <sub>OHH</sub>	-	-	8	mA

ZIGBEE/THREAD BALL Coordinates	Parameter	Test Condition	Min	Typ	Max	Units
	Output sink current high current pad: BOT:[66]	$I_{OLH}$	-	-	8	mA
	Total output current (for I/O Pads)	$I_{OH} + I_{OL}$	-	-	40	mA

Table 46. I/O DC Electrical Characteristics PMIC

PMIC BALL Coordinates	Parameter	Symbol	Test Condition	Min	Typ	Max	Units
PAF:[1]	Low level input voltage	$V_{IL}$	-	-	-	0.40	V
	High level input voltage	$V_{IH}$	-	2.31	-	3.30	V
PAL:[19]	Low level input voltage	$V_{IL}$	-	-	-	0.40	V
	High level input voltage	$V_{IH}$	-	1.40	-	3.30	V

Table 47. I/O DC Electrical Characteristics GPIO

BALL Coordinates	Parameter	Symbol	Condition	Min	Typ	Max	Unit
PAK:[43] PAL:[43]	High level input voltage	$V_{IH}$	-	2.0	-	-	V
	Low level input voltage	$V_{IL}$	-	-	-	0.8	
PAJ:[42,43]	Output High voltage	$V_{OH}$	at 2mA	2.9	-	-	V
	Output Low voltage	$V_{OL}$	at 2mA	-	-	0.4	

Table 48. GPIO Pull-up Resistor Current

BALL Coordinates	Condition	Pull Up	Min	Typ	Max	Unit
PA:[1,2,3,5,6,7,8,29,37,39,40,41,42] PB:[2,3,4,5,6,7,8,39,40,41,42] PAK:[1,2,3,4,5,6,7,8,9,10,11,20,21,22,23,24,25,26,27,28,29,30,31,32,33,34,35,36,37,38,39,40,41,42] PAL:[1,2,3,4,5,6,7,8,9,10,11,20,21,22,23,24,25,26,27,28,29,30,31,32,33,34,35,36,37,38,39,40,41,42] PAC:[1,2] PAD:[1,2] PAE:[1] PAG:[2,42,43] PAH:[1,2,42,43] PAJ:[1,2]	Every GPIO has a 100kΩ internal pull-up resistor	Enable	10	33	72	μA
Disable		-	-	0.1	μA	

\*Based on 100kΩ internal pull-up resistor

Table 49. Power on Reset Timing Specifications

Symbol	Parameter	Min.	Typ.	Max.	Unit
$t_{RESW}$	Reset assert time after clock stabilization	TBD	-	-	ns

### AC ELECTRICAL CHARACTERISTICS

AC characteristics covered in this section are preliminary and are likely to change.

#### SDMMC AC ELECTRICAL CHARACTERISTICS

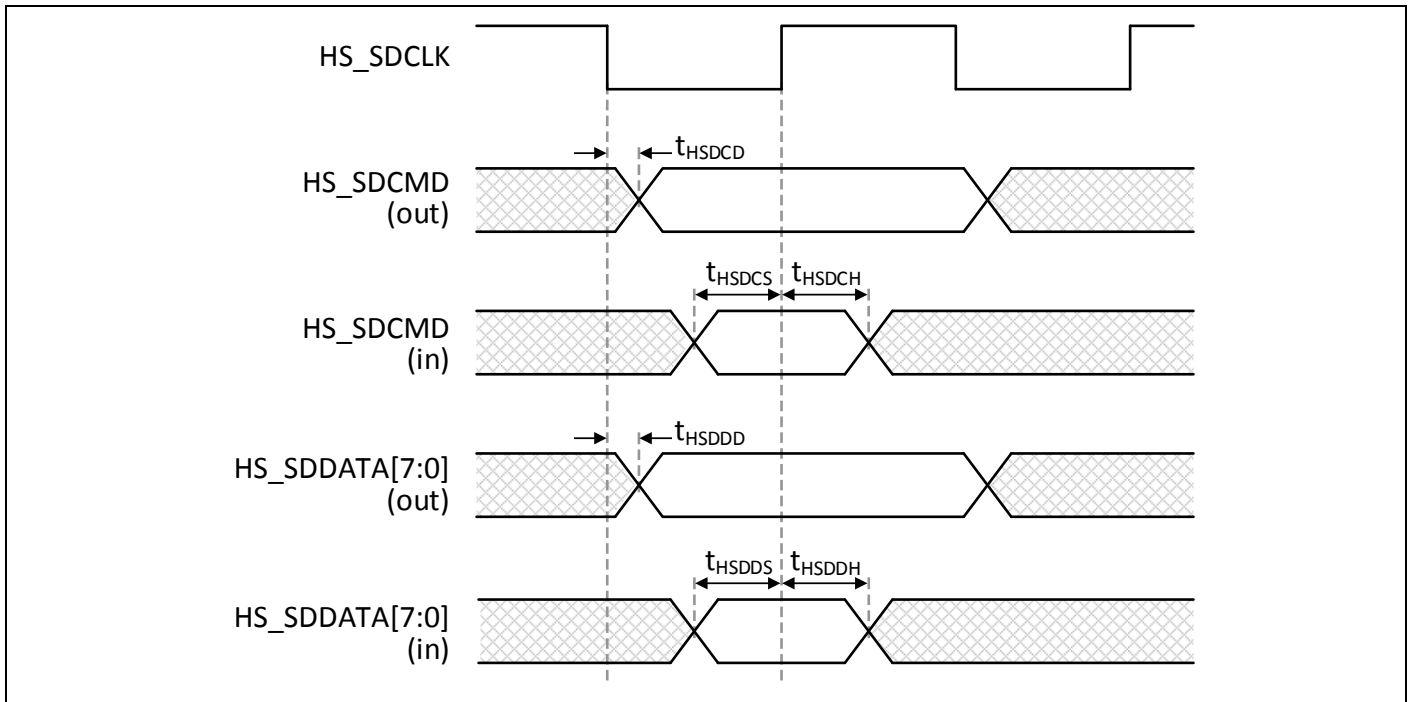

Figure 9. High Speed SDMMC Interface Timing

Table 50. High Speed SDMMC Interface Transmit/Receive Timing Constants

( $V_{DDINT} = 1.0V \pm 5\%$ ,  $T_A = -25$  to  $85^\circ C$ ,  $V_{DDmmc} = 3.3V \pm 5\%$ ,  $2.5V \pm 5\%$ ,  $1.8V \pm 5\%$ )

BOT:[59,60,61,62,63,64]					
Symbol	Parameter	Min	Typ	Max	Unit
$t_{SDCD}$	SD command output delay time	-	-	4.0	ns
$t_{SDCS}$	SD command input setup time	4.0	-	-	
$t_{SDCH}$	SD command input hold time	0	-	-	
$t_{SDDD}$	SD data output delay time	-	-	4.0	
$t_{SDDS}$	SD data input setup time	4.0	-	-	
$t_{SDDH}$	SD data input hold time	0	-	-	

SPI AC ELECTRICAL CHARACTERISTICS

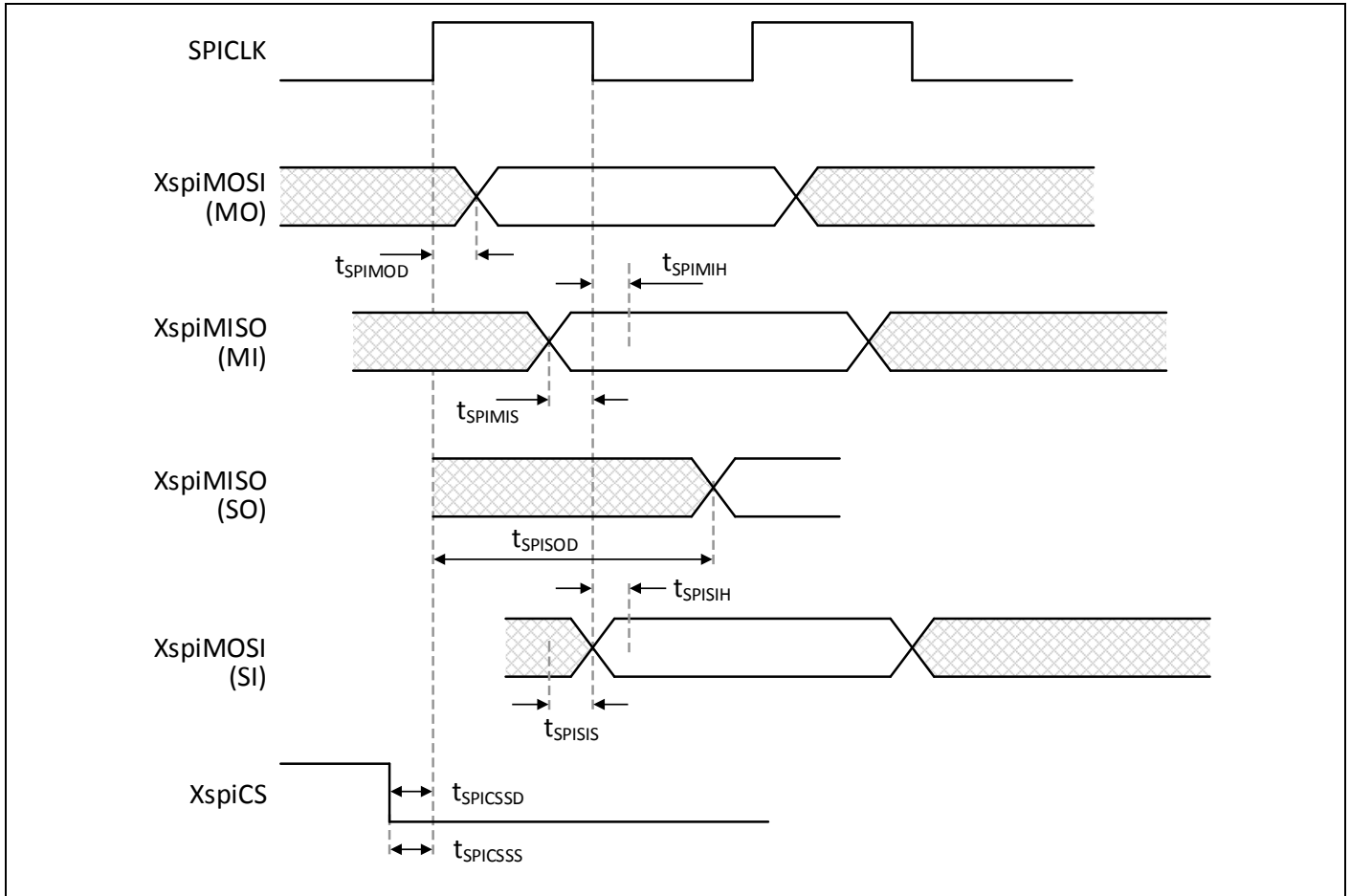

Figure 10. SPI Interface Timing (CPHA = 0, CPOL = 1 (Format A))

Table 51. SPI Interface Transmit/ Receive Timing Constants with 15pF Load

(V<sub>DDINT</sub> = 1.0 V ± 5 %, T<sub>A</sub> = -25 to 85 °C, V<sub>DDext</sub> = 1.8 V ± 10 %, load = 15 pF)

Parameter	Symbol	Min.	Typ.	Max.	Unit		
Ch 0	SPI MOSI Master Output Delay time	t <sub>SPIMOD</sub>	-	-	5	ns	
	SPI MISO Master Input Setup time (FB_CLK_SEL = 00)	t <sub>SPIMIS</sub>	12	-	-		
	SPI MISO Master Input Setup time (FB_CLK_SEL = 01)		7	-	-		
	SPI MISO Master Input Setup time (FB_CLK_SEL = 10)		2	-	-		
	SPI MISO Master Input Setup time (FB_CLK_SEL = 11)		-3	-	-		
	SPI MISO Master Input Hold time		t <sub>SPIMIHI</sub>	5	-		-
	Ch 0	SPI MOSI Slave Input Setup time	t <sub>SPISIS</sub>	2	-	-	ns
		SPI MOSI Slave Input Hold time	t <sub>SPISIH</sub>	5	-	-	
		SPI MISO Slave Output Delay time	t <sub>SPISOD</sub>	-	-	17	
		SPI nSS Master Output Delay time	t <sub>SPICSSD</sub>	7	-	-	
		SPI nSS Slave Input Setup time	t <sub>SPICSSS</sub>	5	-	-	
		Ch 1	SPI MOSI Master Output Delay time	t <sub>SPIMOD</sub>	-	-	
SPI MISO Master Input Setup time (FB_CLK_SEL = 00)	t <sub>SPIMIS</sub>		13	-	-		
SPI MISO Master Input Setup time (FB_CLK_SEL = 01)			8	-	-		
SPI MISO Master Input Setup time (FB_CLK_SEL = 10)			3	-	-		
SPI MISO Master Input Setup time (FB_CLK_SEL = 11)			-2	-	-		
SPI MISO Master Input Hold time			t <sub>SPIMIHI</sub>	5	-	-	
Ch 1	SPI MOSI Slave Input Setup time		t <sub>SPISIS</sub>	3	-	-	ns
	SPI MOSI Slave Input Hold time		t <sub>SPISIH</sub>	5	-	-	
	SPI MISO Slave Output Delay time		t <sub>SPISOD</sub>	-	-	18	
	SPI nSS Master Output Delay time		t <sub>SPICSSD</sub>	7	-	-	
	SPI nSS Slave Input Setup time		t <sub>SPICSSS</sub>	5	-	-	

**Note:** SPICLKout = 50 MHz

- t<sub>SPIMIS,CH0</sub> = 12 - (cycle period/4) x FB\_CLK\_SEL
- t<sub>SPIMIS,CH1</sub> = 13 - (cycle period/4) x FB\_CLK\_SEL

Table 52. SPI Interface Transmit/ Receive Timing Constants with 30pF Load

(VDDINT = 1.0 V ± 5 %, TA = -25 to 85 °C, VDDext = 3.3 V ± 10 %, load = 30 pF)

Parameter		Symbol	Min.	Typ.	Max.	Unit
Ch 0	SPI MOSI Master Output Delay time	t <sub>SPIMOD</sub>	-	-	6	ns
	SPI MISO Master Input Setup time (FB_CLK_SEL = 00)	t <sub>SPIMIS</sub>	13	-	-	
	SPI MISO Master Input Setup time (FB_CLK_SEL = 01)		8	-	-	
	SPI MISO Master Input Setup time (FB_CLK_SEL = 10)		3	-	-	
	SPI MISO Master Input Setup time (FB_CLK_SEL = 11)		-2	-	-	
	SPI MISO Master Input Hold time		t <sub>SPIMIHI</sub>	5	-	
	SPI MOSI Slave Input Setup time	t <sub>SPISIS</sub>	4	-	-	ns
	SPI MOSI Slave Input Hold time	t <sub>SPISIH</sub>	5	-	-	
	SPI MISO Slave Output Delay time	t <sub>SPISOD</sub>	-	-	18	
	SPI nSS Master Output Delay time	t <sub>SPICSSD</sub>	8	-	-	
	SPI nSS Slave Input Setup time	t <sub>SPICSSS</sub>	6	-	-	
Ch 1	SPI MOSI Master Output Delay time	t <sub>SPIMOD</sub>	-	-	5	ns
	SPI MISO Master Input Setup time (FB_CLK_SEL = 00)	t <sub>SPIMIS</sub>	14	-	-	
	SPI MISO Master Input Setup time (FB_CLK_SEL = 01)		9	-	-	
	SPI MISO Master Input Setup time (FB_CLK_SEL = 10)		4	-	-	
	SPI MISO Master Input Setup time (FB_CLK_SEL = 11)		-1	-	-	
	SPI MISO Master Input Hold time	t <sub>SPIMIHI</sub>	5	-	-	
	SPI MOSI Slave Input Setup time	t <sub>SPISIS</sub>	4	-	-	ns
	SPI MOSI Slave Input Hold time	t <sub>SPISIH</sub>	5	-	-	
	SPI MISO Slave Output Delay time	t <sub>SPISOD</sub>	-	-	19	
	SPI nSS Master Output Delay time	t <sub>SPICSSD</sub>	8	-	-	
	SPI nSS Slave Input Setup time	t <sub>SPICSSS</sub>	6	-	-	

**Note:** SPICLKout = 50 MHz

- t<sub>SPIMIS,CH0</sub> = 12 - (cycle period/4) x FB\_CLK\_SEL
- t<sub>SPIMIS,CH1</sub> = 13 - (cycle period/4) x FB\_CLK\_SEL

I<sup>2</sup>C AC ELECTRICAL CHARACTERISTICS

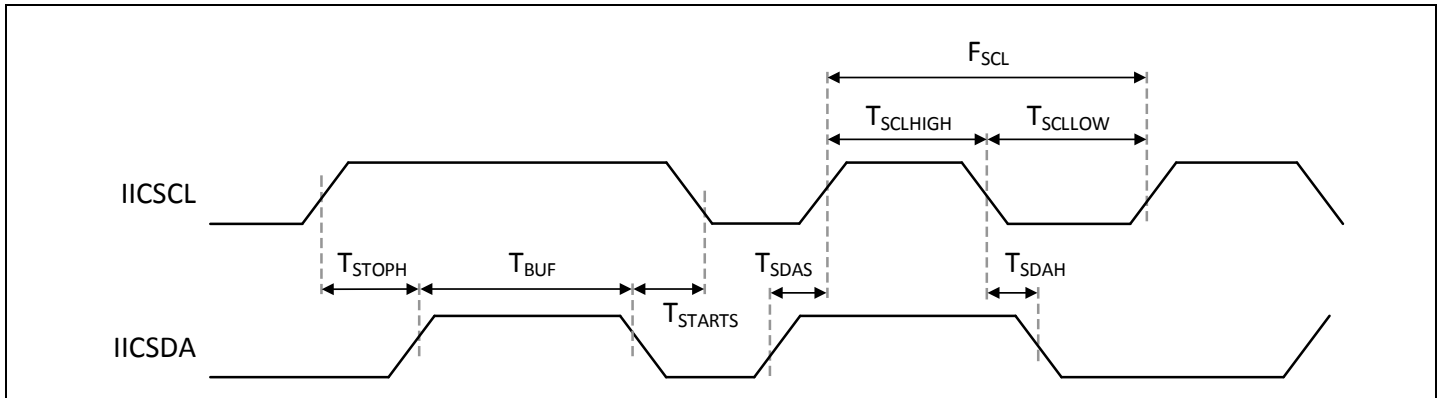

Figure 11. I<sup>2</sup>C Interface Timing

Table 53. I<sup>2</sup>C BUS Controller Module Signal Timing

(VDDINT, VDDarm = 1.1 V ± 5 %, T<sub>A</sub> = -25 to 85 °C, VDDext = 3.3 V ± 10 %)

Parameter	Symbol	Min.	Typ.	Max.	Unit
SCL clock frequency	F <sub>SCL</sub>	-	-	std. 100 fast 400	kHz
SCL high level pulse width	T <sub>SCLHIGH</sub>	std. 4.0 fast 0.6	-	-	μs
SCL low level pulse width	T <sub>SCLLOW</sub>	std. 4.7 fast 1.3	-	-	
Bus free time between STOP and START	T <sub>BUF</sub>	std. 4.7 fast 1.3	-	-	
START hold time	T <sub>STARTS</sub>	std. 4.0 fast 0.6	-	-	
SDA hold time	T <sub>SDAH</sub>	std. 0 fast 0	-	std. fast 0.9	
SDA setup time	T <sub>SDAS</sub>	std. 250 fast 100	-	-	ns
STOP setup time	T <sub>STOPH</sub>	std. 4.0 fast 0.6	-	-	μs

**Note:** std. refers to Standard Mode and fast refers to Fast Mode.

1. The I<sup>2</sup>C data hold time (t<sub>SDAH</sub>) is minimum 0ns.  
(I<sup>2</sup>C data hold time is minimum 0ns for standard/fast bus mode I<sup>2</sup>C specification v2.1)  
Check whether the data hold time of your I<sup>2</sup>C device is 0 ns or not.
2. The I<sup>2</sup>C controller supports I<sup>2</sup>C bus device only (standard/fast bus mode), and does not support C bus device.

## RF ELECTRICAL CHARACTERISTICS

All performance numbers related to 802.11, 802.15.1 and 802.15.4 mentioned in this section are preliminary and likely to change once module characterization has taken place.

### Wi-Fi WLAN 2.4GHZ RECEIVER RF SPECIFICATIONS

Table 54. Wi-Fi WLAN 2.4GHz Receiver RF Specifications

Parameter	Conditions	Min	Typ.	Max	Unit
Frequency Range	-	2400	-	2500	MHz
Minimum receiver sensitivity in 802.11b mode					
1Mbps	PER < 8%, Packet size = 1024 bytes	-	-	-92	dBm
2Mbps		-	-	-80	dBm
5.5Mbps		-	-	-76	dBm
11Mbps		-	-	-83	dBm
Minimum receiver sensitivity in 802.11g mode					
6Mbps	PER < 10%, Packet size= 1024 bytes	-	-	-82	dBm
9Mbps		-	-	-81	dBm
12Mbps		-	-	-79	dBm
18Mbps		-	-	-77	dBm
24Mbps		-	-	-74	dBm
36Mbps		-	-	-70	dBm
48Mbps		-	-	-66	dBm
54Mbps		-	-	-65	dBm
Minimum receiver sensitivity in 802.11n mode					
MCS 0	PER<10%, Packet size= 4096 bytes, GF, 800ns GI, Non-STBC	-	-	-82	dBm
MCS 1		-	-	-79	dBm
MCS 2		-	-	-77	dBm
MCS 3		-	-	-74	dBm
MCS 4		-	-	-70	dBm
MCS 5		-	-	-68	dBm
MCS 6		-	-	-65	dBm
MCS 7		-	-	-64	dBm
Maximum input level					
Maximum input signal level in 802.11b mode	PER < 8%	-10	-	-	dBm
Maximum input signal level in 802.11g mode	PER < 10%	-20	-	-	dBm
Maximum input signal level in 802.11n mode	PER < 10%	-20	-	-	dBm

## Wi-Fi WLAN 2.4GHz TRANSMITTER RF SPECIFICATIONS

Table 55. Wi-Fi WLAN 2.4GHz Transmitter RF Specifications

Parameter	Conditions	Min	Typ.	Max	Unit
Linear output power					
Maximum output power in 802.11b mode	As specified in IEEE802.11	-	16	-	dBm
Maximum output power in 802.11g mode		-	12.5	-	dBm
Maximum output power in 802.11n mode		-	13	-	dBm
Transmit spectrum mask					
Margin to 802.11b spectrum mask	Maximum output power	0	-	-	dB
Margin to 802.11g spectrum mask		0	-	-	dB
Margin to 802.11n spectrum mask		0	-	-	dB
Transmit modulation accuracy in 802.11b mode					
1Mbps	As specified in IEEE 802.11b	-	-	35	%
2Mbps		-	-	35	%
5.5Mbps		-	-	35	%
11Mbps		-	-	35	%
Transmit modulation accuracy in 802.11g mode					
6Mbps	Mandatory	-	-	-5	dB
9Mbps	Optional	-	-	-8	dB
12Mbps	Mandatory	-	-	-10	dB
18Mbps	Optional	-	-	-13	dB
24Mbps	Mandatory	-	-	-16	dB
36Mbps	Optional	-	-	-19	dB
48Mbps	Optional	-	-	-22	dB
54Mbps	Optional	-	-	-25	dB
Transmit modulation accuracy in 802.11n mode					
MCS7	As specified in IEEE 802.11n	-	-	-27	dB
Transmit power-on and power-down ramp time in 802.11b mode					
Transmit power-on ramp time from 10% to 90% output power	-	-	-	2	μs
Transmit power-down ramp time from 90% to 10% output power	-	-	-	2	μs

## Wi-Fi WLAN 5GHz RECEIVER RF SPECIFICATIONS

Table 56. Wi-Fi WLAN 5GHz Receiver RF Specifications

Parameter	Conditions	Min	Typ.	Max	Unit
Frequency Range	-	4900	-	5845	MHz
Minimum receiver sensitivity in 802.11a mode					
6Mbps	PER < 10%	-	-	-82	dBm
12Mbps		-	-	-79	dBm
24Mbps		-	-	-74	dBm
36Mbps		-	-	-70	dBm
48Mbps		-	-	-66	dBm
54Mbps		-	-	-65	dBm
Minimum receiver sensitivity in 802.11n (HT-20) mode					
MCS 0	-	-	-	-82	dBm
MCS 1	-	-	-	-79	dBm
MCS 2	-	-	-	-77	dBm
MCS 3	-	-	-	-74	dBm
MCS 4	-	-	-	-70	dBm

Parameter	Conditions	Min	Typ.	Max	Unit
Frequency Range	-	4900	-	5845	MHz
MCS 5		-	-	-66	dBm
MCS 6		-	-	-65	dBm
MCS 7		-	-	-64	dBm
Minimum receiver sensitivity in 802.11n (HT-40) mode					
MCS 0	PER<10	-	-	-79	dBm
MCS 1		-	-	-76	dBm
MCS 2		-	-	-74	dBm
MCS 3		-	-	-71	dBm
MCS 4		-	-	-67	dBm
MCS 5		-	-	-63	dBm
MCS 6		-	-	-62	dBm
MCS 7		-	-	-61	dBm
Minimum receiver sensitivity in 802.11ac (VHT-20) mode					
MCS 0	PER<10	-	-	-82	dBm
MCS 1		-	-	-79	dBm
MCS 2		-	-	-77	dBm
MCS 3		-	-	-74	dBm
MCS 4		-	-	-70	dBm
MCS 5		-	-	-66	dBm
MCS 6		-	-	-65	dBm
MCS 7		-	-	-64	dBm
MCS 8		-	-	-59	dBm
Minimum receiver sensitivity in 802.11ac (VHT-40) mode					
MCS 0	PER<10	-	-	-79	dBm
MCS 1		-	-	-76	dBm
MCS 2		-	-	-74	dBm
MCS 3		-	-	-71	dBm
MCS 4		-	-	-67	dBm
MCS 5		-	-	-63	dBm
MCS 6		-	-	-62	dBm
MCS 7		-	-	-61	dBm
MCS 8		-	-	-56	dBm
MCS 9		-	-	-54	dBm
Minimum receiver sensitivity in 802.11ac (VHT-80) mode					
MCS 0	PER<10	-	-	-76	dBm
MCS 1		-	-	-73	dBm
MCS 2		-	-	-71	dBm
MCS 3		-	-	-68	dBm
MCS 4		-	-	-64	dBm
MCS 5		-	-	-60	dBm
MCS 6		-	-	-59	dBm
MCS 7		-	-	-58	dBm
MCS 8		-	-	-53	dBm
MCS 9		-	-	-51	dBm
Maximum input level					
Maximum input signal level in 802.11a mode	PER < 10%	-30	-	-	dBm
Maximum input signal level in 802.11n mode	PER < 10%	-30	-	-	dBm
Maximum input signal level in 802.11ac mode	PER < 10%	-30	-	-	dBm

## Wi-Fi WLAN 5GHz TRANSMITTER RF SPECIFICATIONS

Table 57. Wi-Fi WLAN 5GHz Transmitter RF Specifications

Parameter	Conditions	Min	Typ.	Max	Unit
Frequency Range	-	4900		5845	MHz
Linear output power					
Maximum output power in 802.11a mode	54M, UNII-2e	-	12.5	-	dBm
Maximum output power in 802.11n mode	HT20, MCS7, UNII-2e	-	12	-	dBm
	HT40, MCS7, UNII-2e	-	11	-	dBm
Maximum output power in 802.11ac mode	VHT20, MCS8, UNII-2e	-	12	-	dBm
	VHT40, MCS9, UNII-2e	-	11	-	dBm
	VHT80, MCS9, UNII-2e	-	8	-	dBm
Transmit spectrum mask					
Margin to 802.11a spectrum mask	Maximum output power	0	-	-	dBr
Margin to 802.11n spectrum mask		0	-	-	dBr
Margin to 802.11ac spectrum mask		0	-	-	dBr
Transmit constellation error in 802.11a mode					
54Mbps	As specified in IEEE 802.11n	-	-	-25	dB
Transmit constellation error in 802.11n (HT-20, HT-40) mode					
MCS 7	As specified in IEEE 802.11n	-	-	-27	dB
Transmit constellation error in 802.11ac (VHT-20) mode					
MCS 8	As specified in IEEE 802.11n	-	-	-30	dB
Transmit constellation error in 802.11ac (VHT-40, VHT-80) mode					
MCS 9	As specified in IEEE 802.11n	-	-	-32	dB

## BLUETOOTH RF SPECIFICATIONS

Table 58. Bluetooth Receiver RF Specifications

Parameter	Conditions	Min	Typ	Max	Unit
Frequency Range	-	2402	-	2480	MHz
Sensitivity (BER)	GPSK, BER $\leq 0.1\%$	-	-	-80	dBm
	$\pi/4$ -DQPSK, BER $\leq 0.01\%$	-	-	-80	dBm
	BER $\leq 0.01\%$ , 8DPSK	-	-	-80	dBm
Maximum Input Level	GPSK, BER $\leq 0.1\%$	-20	-	-	dBm
	$\pi/4$ -DQPSK, BER $\leq 0.1\%$	-20	-	-	dBm
	BER $\leq 0.1\%$ , 8 DPSK	-20	-	-	dBm
BDR					
Intermodulation Performance	-	-	-	0.1	%
Rx C/I Performance	1DH1	-	-	0.1	%
	1DH3	-	-	0.1	%
	1DH5	-	-	0.1	%
EDR					
Rx C/I Performance	2DH1	-	-	0.1	%
	2DH3	-	-	0.1	%
	2DH5	-	-	0.1	%
	3DH1	-	-	0.1	%
	3DH3	-	-	0.1	%
	3DH5	-	-	0.1	%
Rx BER Floor Performance	BER $\leq 0.001\%$	-	-	-70	dBm

Table 59. Bluetooth Transmitter RF Specifications

Parameter	Conditions	Min	Typ	Max	Unit
Frequency Range	-	2402	-	2480	MHz
Output Power (Average)					
BDR (QPSK)	2440 MHz	-	7	-	dBm
EDR ( $\pi/4$ -DQPSK)	2440 MHz	-	3	-	dBm
EDR (8DPSK)	2440 MHz	-	3	-	dBm

Table 60. BLE RF Specifications

Parameter	Conditions	Min	Typ	Max	Unit
Frequency Range	-	2402	-	2480	MHz
Rx Receiver Sensitivity PER	@ -70dBm	-	-	30.8	%
Rx C/I and Receiver Selectivity Performance PER	-	-	-	30.8	%
Tx Power	-	-	7	-	dBm

### 802.15.4 RF RECEIVE SPECIFICATIONS

Receive measurements were collected with the 802.15.4 SoC Ceramic Balun Reference Design (Version A0) at 2440MHz. The typical number indicates one standard deviation above the mean, measured at room temperature (25°C). The Min and Max numbers were measured over process corners at room temperature.

Table 61. 802.15.4 RF Receive Specifications

Parameter	Test Condition	Min	Typ	Max	Unit
Frequency range		2400	-	2500	MHz
Sensitivity (boost mode)	1% PER, 20 byte packet defined by IEEE 802.15.4-2003;	-	-102	-96	dBm
Sensitivity	1% PER, 20 byte packet defined by IEEE 802.15.4-2003;	-	-100	-94	dBm
High-side adjacent channel rejection	IEEE 802.15.4-2003 interferer signal, wanted IEEE 802.15.4-2003 signal at -82 dBm	-	35	-	dB
Low-side adjacent channel rejection	IEEE 802.15.4-2003 interferer signal, wanted IEEE 802.15.4-2003 signal at -82 dBm	-	35	-	dB
2nd high-side adjacent channel rejection	IEEE 802.15.4-2003 interferer signal, wanted IEEE 802.15.4-2003 signal at -82 dBm	-	46	-	dB
2nd low-side adjacent channel rejection	IEEE 802.15.4-2003 interferer signal, wanted IEEE 802.15.4-2003 signal at -82 dBm	-	46	-	dB
High-side adjacent channel rejection	Filtered IEEE 802.15.4-2003 interferer signal, wanted IEEE 802.15.4-2003 signal at -82 dBm	-	39	-	dB
Low-side adjacent channel rejection	Filtered IEEE 802.15.4-2003 interferer signal, wanted IEEE 802.15.4-2003 signal at -82 dBm	-	47	-	dB
2nd high-side adjacent channel rejection	Filtered IEEE 802.15.4-2003 interferer signal, wanted IEEE 802.15.4-2003 signal at -82 dBm	-	49	-	dB
2nd low-side adjacent channel rejection	Filtered IEEE 802.15.4-2003 interferer signal, wanted IEEE 802.15.4-2003 signal at -82 dBm	-	49	-	dB
High-side adjacent channel rejection	CW interferer signal, wanted IEEE 802.15.4-2003 signal at -82 dBm	-	44	-	dB
Low-side adjacent channel rejection	CW interferer signal, wanted IEEE 802.15.4-2003 signal at -82 dBm	-	47	-	dB
2nd high-side adjacent channel rejection	CW interferer signal, wanted IEEE 802.15.4-2003 signal at -82 dBm	-	59	-	dB
2nd low-side adjacent channel rejection	CW interferer signal, wanted IEEE 802.15.4-2003 signal at -82 dBm	-	59	-	dB
Channel rejection for all other channels	IEEE 802.15.4-2003 interferer signal, wanted IEEE 802.15.4-2003 signal at -82 dBm	-	40	-	dB
802.11g rejection centered at +12 MHz or -13 MHz	IEEE 802.15.4-2003 interferer signal, wanted IEEE 802.15.4-2003 signal at -82 dBm	-	36	-	dB
Maximum input signal level for correct operation		0	-	-	dBm
Co-channel rejection	IEEE 802.15.4-2003 interferer signal, wanted IEEE 802.15.4-2003 signal at -82 dBm	-	-6	-	dBc
Relative frequency error (50% greater than the 2x40 ppm required by IEEE 802.15.4-2003)		-120	-	+120	ppm
Relative timing error (50% greater than the 2x40 ppm required by IEEE 802.15.4-2003)		-120	-	+120	ppm
Linear RSSI range	As defined by IEEE 802.15.4-2003	40	-	-	dB
RSSI Range		-90	-	-40	dB

### 802.15.4 RF TRANSMIT SPECIFICATIONS

Transmit measurements were collected with the Silicon Labs 802.15.4 SoC ceramic balun reference design (Version A0) at 2440MHz. The typical number indicates one standard deviation below the mean, measured at room temperature of 25°C. The Min and Max numbers were measured over process corners at room temperature. In terms of impedance, this reference design presents a 3n3 inductor in parallel with a 100:50Ω balun to the RF pins.

Table 62. ZigBee/Thread RF Transmit Specifications

Parameter	Test Condition	Min	Typ	Max	Unit
Maximum output power	At highest normal mode power setting (+3)	-3	6.5	-	dBm
Minimum output power	At lowest power setting	-	-55	-	dBm
Error vector magnitude (Offset-EVM)	As defined by IEEE 802.15.4-2003, which sets a 35% maximum	-	-	10	%
Carrier frequency error	-	-40	-	+40	ppm
PSD mask relative	3.5 MHz away (Normal)	-20	-	-	dBm
PSD mask absolute	100 KHz BW	-30	-	-	dBm

Table 63. ZigBee/Thread RF Receive Specifications

Parameter	Test Condition	Min	Typ	Max	Unit
Operating Frequency Range		2400	-	2483.5	MHz
Receiver Sensitivity PER	@[-95dBm]	-	-	1	%
Receiver Sensitivity Search	@PER 1%	-	-	-95	dBm
Receiver Interference Rejection PER	@[-2 Channel, Alternate Channel, 30dB]	-	-	1	%
Receiver Interference Rejection PER	@[-1 Channel, Adjacent Channel, 0dB]	-	-	1	%
Receiver Interference Rejection PER	@[+1 Channel, Adjacent Channel, 0dB]	-	-	1	%
Receiver Interference Rejection PER	@[+2 Channel, Alternate Channel, 30dB]	-	-	1	%
Error Vector Magnitude - RMS (EVM)	@[Target Power]	-	-	30	%
Error Vector Magnitude - Offset (EVM)	@[Target Power]	-	-	10	%
Receiver Maximum Input Level of Desired Signal	@[-20dBm Input]	-	-	1	%

# ARTIK 710 MODULE MECHANICAL SPECIFICATIONS

The ARTIK 710 Module supports PAD Balls and two RF connectors on a 49mm x 36mm footprint. Refer to section [ARTIK 710 Module Antenna Connections](#) for RF connector details. [Figure 12](#) and [Figure 13](#) show the mechanical dimensions of the ARTIK 710 Module and the Bottom and Top View respectively.

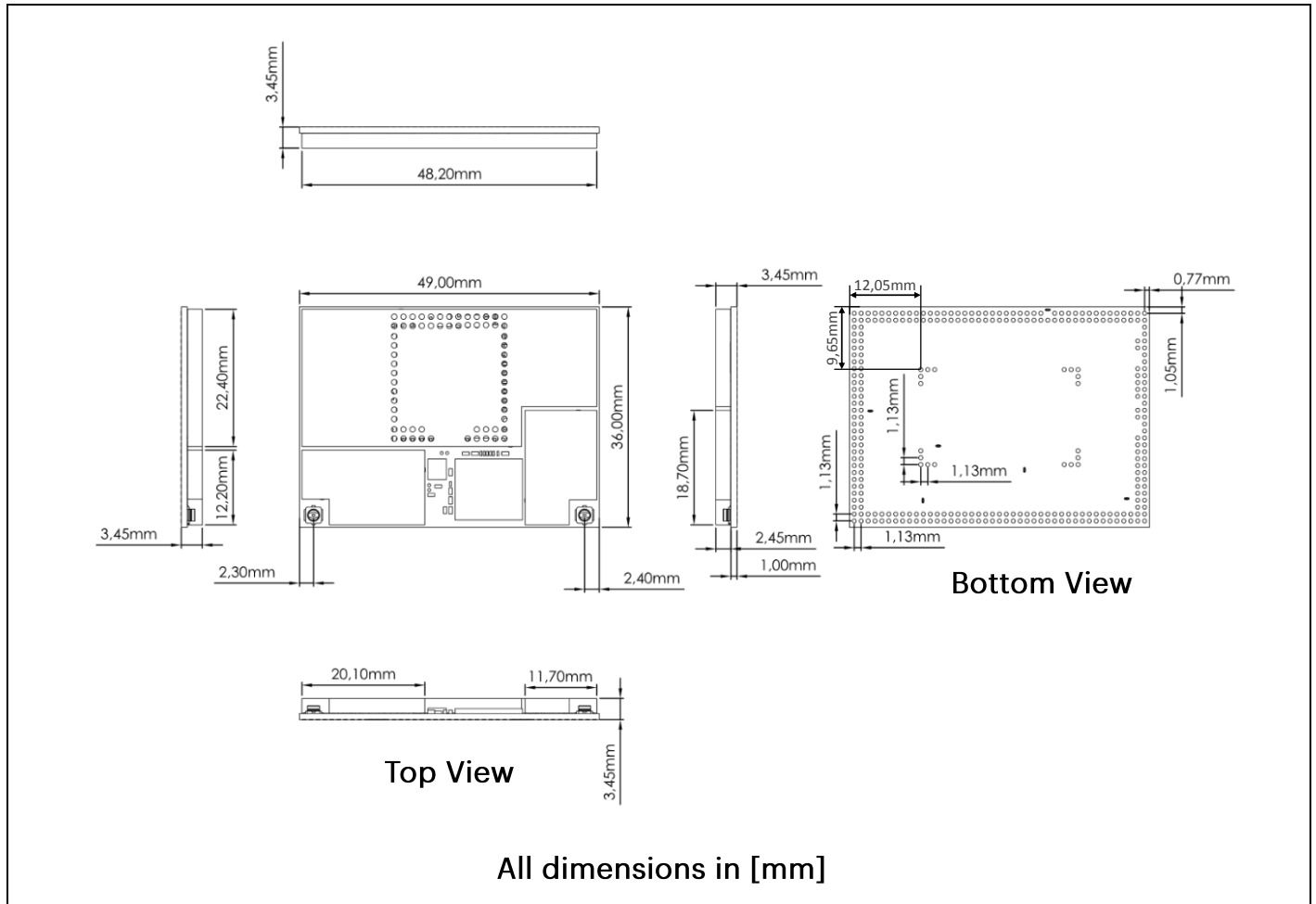

Figure 12. ARTIK 710 Module Mechanical Dimensions

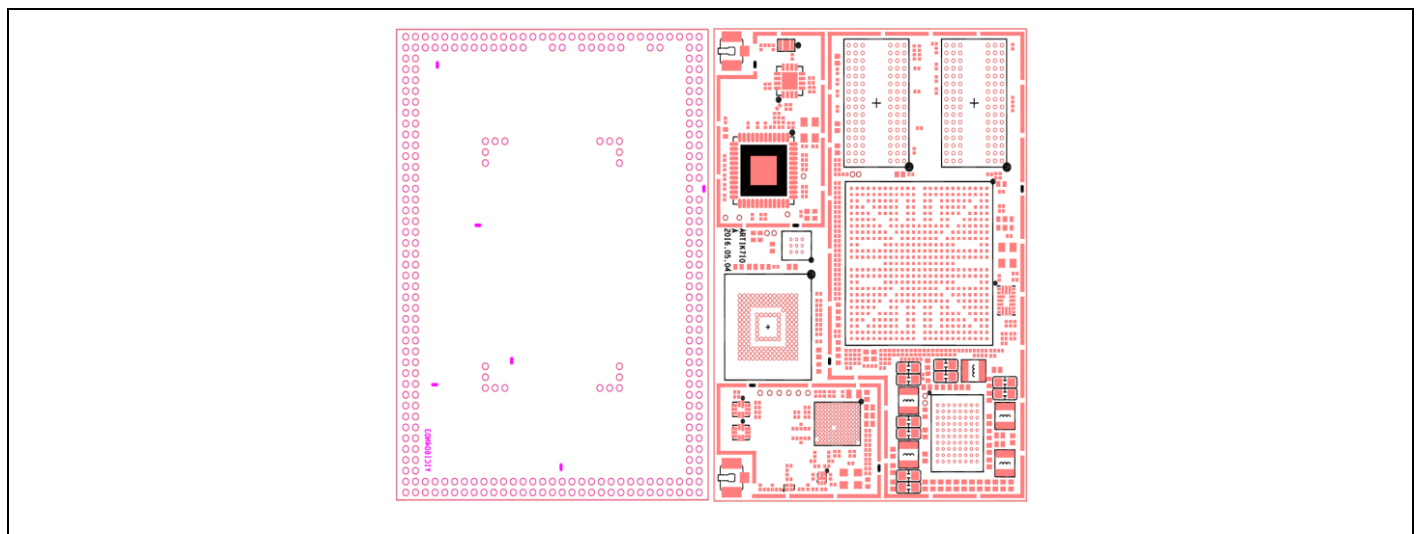

Figure 13. Mechanical Bottom View and Top View

All outer pin locations can be extracted from the mechanical dimensions provided in *Figure 12*. The inner pin locations on the PAD, positioned in an L-shaped form, as depicted in *Figure 14*, are located in *Table 64*. The locations given in the table are the absolute coordinates measured from the edge of the ARTIK 530 Module.

Table 64. L-Shaped Ball Locations

Ball Name	Ball Number	Netlist Name	X-Location ↑ [mm]	Y-Location → [mm]
TP	282	GND	26.35	12.05
TP	283	GND	26.35	13.18
TP	284	GND	26.35	14.31
TP	285	GND	26.35	35.49
TP	286	GND	26.35	36.62
TP	287	GND	26.35	37.75
TP	288	GND	25.22	37.75
TP	289	GND	24.09	37.75
TP	290	GND	13.11	37.75
TP	291	GND	11.98	37.75
TP	292	GND	10.85	37.75
TP	293	GND	10.85	36.62
TP	294	GND	10.85	35.49
TP	295	GND	10.85	14.31
TP	296	GND	10.85	13.18
TP	297	GND	10.85	12.05
TP	298	GND	11.98	12.05
TP	299	GND	13.11	12.05
TP	300	GND	24.09	12.05
TP	301	GND	25.22	12.05

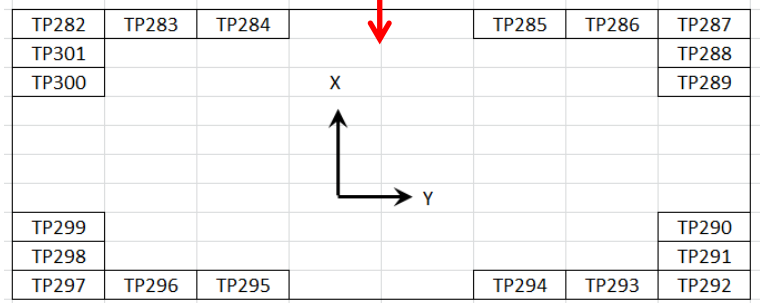
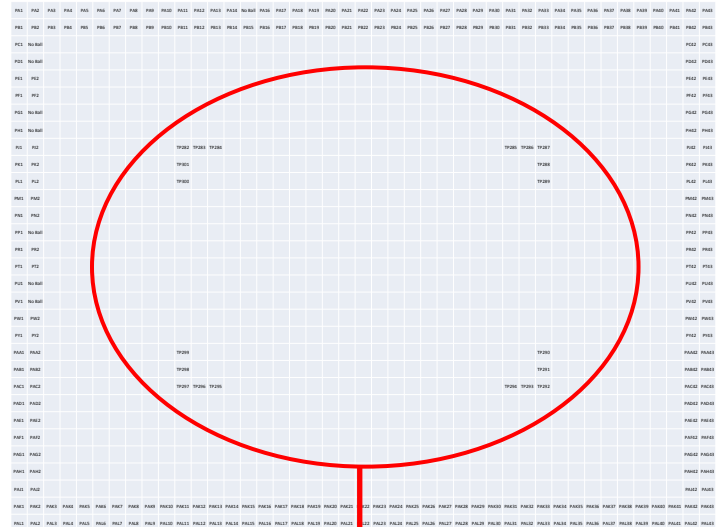

Figure 14. L-Shaped PAD Pins

## ORDERING INFORMATION

Type	Order Number	Description
ARTIK 710 Module	SIP007AFS001	1x ARTIK 710 Module
ARTIK 710 Development Kit	SIP-KITNXE001	1x ARTIK 710 Module 1x ARTIK 710 Interposer Board 1x Platform Board 1x Interface Board 2x Antennas (1x ZigBee, 1x Wi-Fi)

For volume ordering of evaluation kits, please contact a sales representative in your area or email [sales@artik.io](mailto:sales@artik.io).

## LEGAL INFORMATION

INFORMATION IN THIS DOCUMENT IS PROVIDED IN CONNECTION WITH THE SAMSUNG ARTIK™ DEVELOPMENT KIT AND ALL RELATED PRODUCTS, UPDATES, AND DOCUMENTATION (HEREINAFTER “SAMSUNG PRODUCTS”). NO LICENSE, EXPRESS OR IMPLIED, BY ESTOPPEL OR OTHERWISE, TO ANY INTELLECTUAL PROPERTY RIGHTS IS GRANTED BY THIS DOCUMENT. THE LICENSE AND OTHER TERMS AND CONDITIONS RELATED TO YOUR USE OF THE SAMSUNG PRODUCTS ARE GOVERNED EXCLUSIVELY BY THE SAMSUNG ARTIK™ DEVELOPER LICENSE AGREEMENT THAT YOU AGREED TO WHEN YOU REGISTERED AS A DEVELOPER TO RECEIVE THE SAMSUNG PRODUCTS. EXCEPT AS PROVIDED IN THE SAMSUNG ARTIK™ DEVELOPER LICENSE AGREEMENT, SAMSUNG ELECTRONICS CO., LTD. AND ITS AFFILIATES (COLLECTIVELY, “SAMSUNG”) ASSUMES NO LIABILITY WHATSOEVER, INCLUDING WITHOUT LIMITATION CONSEQUENTIAL OR INCIDENTAL DAMAGES, AND SAMSUNG DISCLAIMS ANY EXPRESS OR IMPLIED WARRANTY, ARISING OUT OF OR RELATED TO YOUR SALE, APPLICATION AND/OR USE OF SAMSUNG PRODUCTS INCLUDING LIABILITY OR WARRANTIES RELATED TO FITNESS FOR A PARTICULAR PURPOSE, MERCHANTABILITY, OR INFRINGEMENT OF ANY PATENT, COPYRIGHT, OR OTHER INTELLECTUAL PROPERTY RIGHT.

SAMSUNG RESERVES THE RIGHT TO CHANGE PRODUCTS, INFORMATION, DOCUMENTATION AND SPECIFICATIONS WITHOUT NOTICE. THIS INCLUDES MAKING CHANGES TO THIS DOCUMENTATION AT ANY TIME WITHOUT PRIOR NOTICE. THIS DOCUMENTATION IS PROVIDED FOR REFERENCE PURPOSES ONLY, AND ALL INFORMATION DISCUSSED HEREIN IS PROVIDED ON AN “AS IS” BASIS, WITHOUT WARRANTIES OF ANY KIND. SAMSUNG ASSUMES NO RESPONSIBILITY FOR POSSIBLE ERRORS OR OMISSIONS, OR FOR ANY CONSEQUENCES FROM THE USE OF THE DOCUMENTATION CONTAINED HEREIN.

Samsung Products are not intended for use in medical, life support, critical care, safety equipment, or similar applications where product failure could result in loss of life or personal or physical harm, or any military or defense application, or any governmental procurement to which special terms or provisions may apply.

This document and all information discussed herein remain the sole and exclusive property of Samsung. All brand names, trademarks and registered trademarks belong to their respective owners. For updates or additional information about Samsung ARTIK™, contact the Samsung ARTIK™ team via the Samsung ARTIK™ website at [www.artik.io](http://www.artik.io).

Copyright © 2016 Samsung Electronics Co., Ltd.

All rights reserved. No part of this publication may be reproduced, stored in a retrieval system, or transmitted in any form or by any means, electric or mechanical, by photocopying, recording, or otherwise, without the prior written consent of Samsung Electronics.

## Looking for pricing, stock, or lifecycle information?

Click below to explore more details on WIN SOURCE:

 [View SIP-ASRNXS001 on WIN SOURCE](#)

 [Samsung Information](#)

## Optimize Your Supply Chain with WIN SOURCE Solutions

-  Global Sourcing Solution
-  Obsolete Management
-  Cost Control Management
-  Shortage Management
-  Alternative Solution
-  Excess Inventory Management