

Specifications

Drawing No.	UKY1C-H1-16228-00[32] 1/10
Issued Date.	Mar. 2,2016

TO: Digi-Key

Note: In case of specification change, KYOCERA Part Number also will be changed.

Product Name	Quartz Crystal
Product Model	CX8045GA
Frequency	4000kHz
Customer Part Number	-
Customer Specification Number	-
KYOCERA Part Number	CX8045GA04000H0PST03
Remarks	RoHS Compliant, MSL 1 AEC-Q200 conformity

Customer Acceptance

Accept Signature	Approved Date	
	Department	
	Person in charge	

Seller

KYOCERA Crystal Device Corporation

(Crystal products Sales Division)

6 Takeda Tobadono-cho, Fushimi-ku, Kyoto

612-8501 Japan

TEL. No. 075-604-3500

FAX. No. 075-604-3501

Manufacturer

Crystal Units Division

5850, Higashine-Koh, Higashine-Shi, Yamagata

999-3701 Japan

TEL. No. 0237-43-5611

FAX. No. 0237-43-5615

Design Department	Quality Assurance	Approved by	Examination by	Issued by
KYOCERA Crystal Device Corporation Crystal Units Engineering Section Crystal Units Division	T. Noritake	H. Shoji	A.Ito	M.Hashimoto

Revision History

Rev.No.	Description of revise	Date	Approved by	Examination by	Issued by
1	First Edition	Mar. 2,2016	H.Shoji	A.Ito	M. Hashimoto

1. APPLICATION

This specification sheet is applied to quartz crystal "CX8045GA04000H0PST03"

2. KYOCERA PART NUMBER

CX8045GA04000H0PST03

3. RATINGS

Items	SYMB.	Rating	Unit	Remarks
Operating Temperature	Topr	-40 to +125	°C	
Storage Temperature Range	Tstg	-40 to +150	°C	

4. CHARACTERISTICS

ELECTRICAL CHARACTERISTICS

Items	Electrical Specification					Test Condition	Remarks
	SYMB.	Min.	Typ.	Max.	Unit		
Mode of Vibration		Fundamental					
Nominal Frequency	F0		4		MHz		
Nominal Temperature	T _{NOM}		+25		°C		
Load Capacitance	CL		12.0		pF		
Frequency Tolerance	df/F	-50.0		+50.0	PPM	25 ±3°C	
Frequency Temperature Characteristics	df/F	-100.0		+100.0		-40 to +125°C	
Frequency Aging Rate		-5.0		+5.0		1 st year	+25 ±3°C
Equivalent Series Resistance	ESR			300	Ω		
Drive Level	Pd	0.01		500	μW		
Insulation Resistance	IR	500			MΩ	100V(DC)	

5. MEASUREMENT CONDITION

5.1 Frequency measurement

Measuring instrument : PI-Network Test Fixture

Load Capacitance : 12.0pF

Drive Level : 10 μ W

5.2 Equivalent series resistance (ESR) measurement

Measuring instrument : PI-Network Test Fixture

Load Capacitance : Series

Drive Level : 10 μ W

6. APPEARANCES, PHYSICAL DIMENSION

OUTLINE DIMENSION (not to scale)

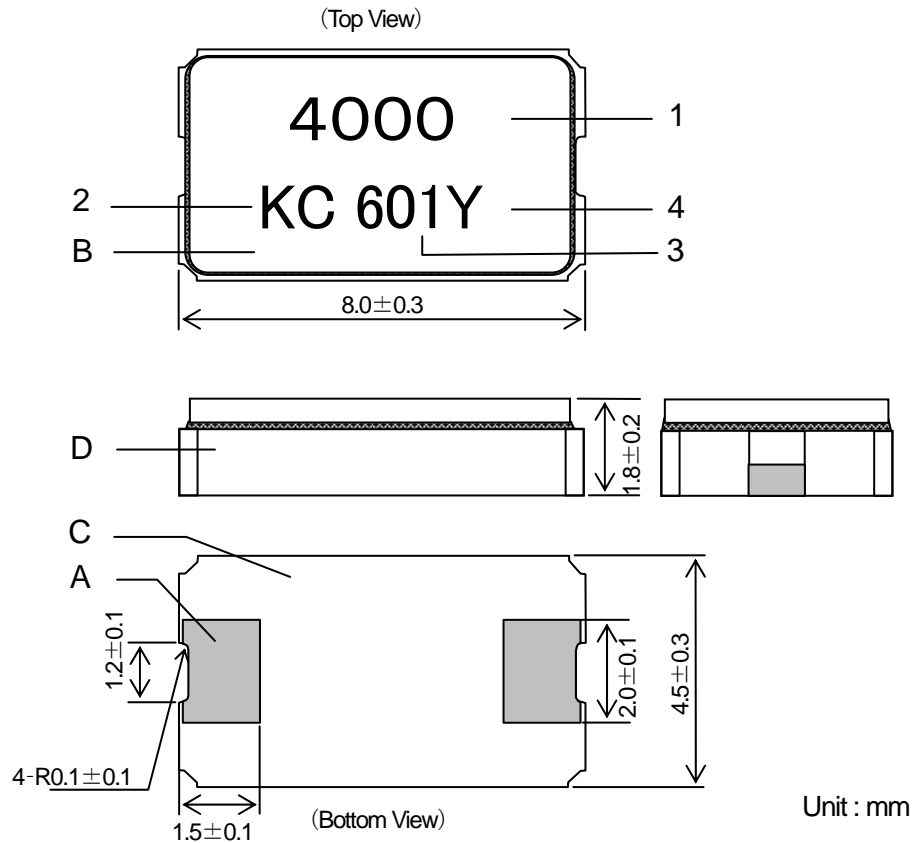

A	Terminal	W-Ni-Au (Pb-Free)
B	CAP	CERAMICS (BLACK)
C	BASE	CERAMICS (BLACK)
D	GLASS	LOW TEMPERATURE GLASS
	MARKING	NOTE
1	NOMINAL FREQUENCY	(5 DIGITS MAX) UNIT: kHz
2	IDENTIFICATION	—
3	DATE CODE	YEAR LAST 1 DIGIT of YEAR AND WEEK EXAMPLE Jan. 1, 2016 → 601
4	MANUFACTURING LOCATION	Y . . . Japan (Yamagata) T . . . Thailand
*The font of marking is reference.		

7. RECOMMENDED LAND PATTERN (not to scale)

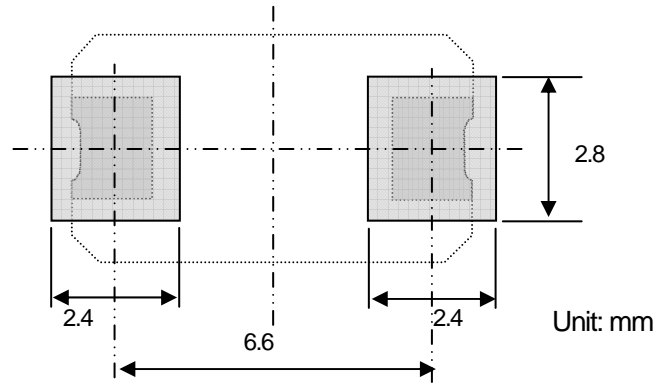

8.TAPING & REEL

8-1.Dimensions

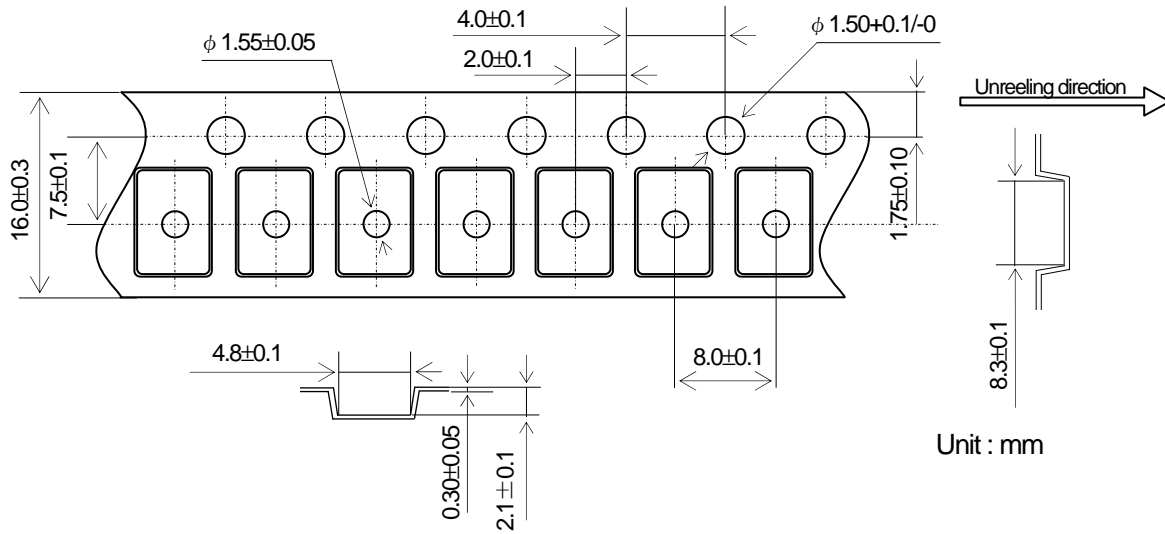

8-2.Leader and trailer tape

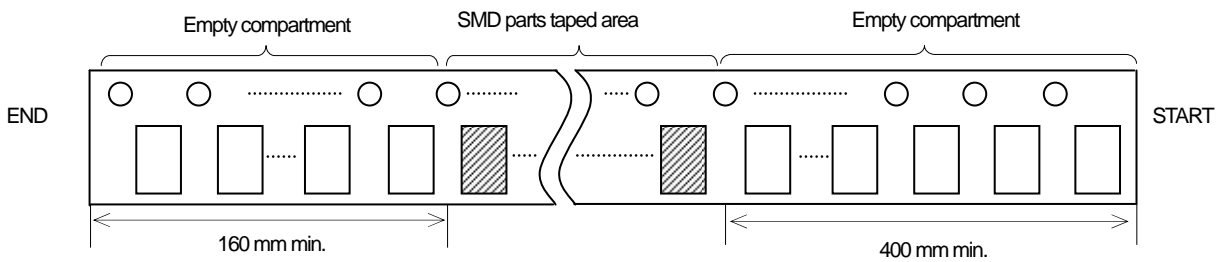

8-3.Specification

1. Material of the carrier tape shall be A—PET or PS (ESD)
2. The seal tape shall not cover the sprocket holes. And not protrude from the carrier tape.
3. Tensile strength of the tape : 10N or more.
4. The number of lack is 0.1% of 1 reel total part number (the number of the table letters) or the part following whose 1 either is big. (But, the thing which lack of the continuance is not in.)
5. The R of the corner without designation is 0.3R MAX.
6. Disalignment between centers of the cavity and sprocket hole shall be 0.05mm or less.
7. Peeling force of the seal tape (Peeling speed 300mm/min.): 0.1 to 1.0N
8. Cumulative pitch error of feed hole : 50 pitch $\rightarrow \pm 0.3$ mm
9. The marking on parts is not fixed its direction, its electrical characteristic is equal.

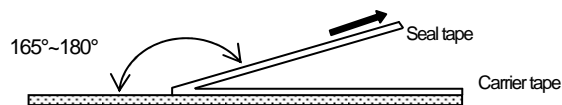

8-4.Reel specifications

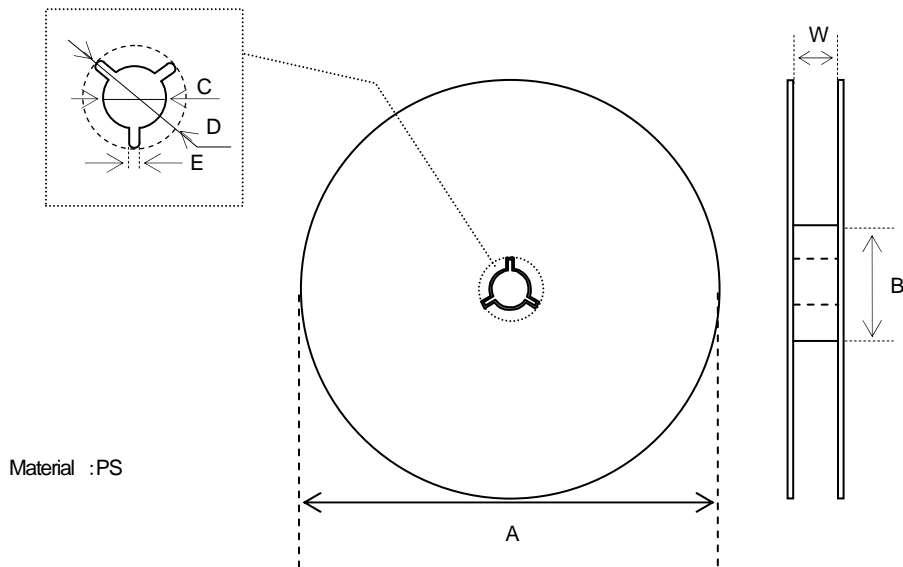

φ 254 Reel (1,000 pcs. Max.)

Symbol	A	B	C	D
Dimension	φ 254	φ 100	φ 13	φ 21
Symbol	E	W		
Dimension	2.0	22.4		

(Unit : mm)

φ 330 Reel (3,000 pcs.)

Symbol	A	B	C	D
Dimension	φ 330	φ 100	φ 13	φ 21
Symbol	E	W		
Dimension	2.0	22.4		

(Unit : mm)

9.Environmental requirements

(Reference: AEC-Q200 Rev. D. The solder used by examination is hereafter set to Sn-3Ag-0.5Cu.)
 After following test, Frequency applies to each item and CI, $\pm 20\%$ or 5Ω of large value.

No	Stress	Reference	Additional Requirements
9.1	High Temperature Exposure (Storage)	MIL-STD-202 Method 108	1000 hrs. at rated operating temperature (e.g. 85°C part can be stored for 1000 hrs at 85°C. Same applies for 125°C). Unpowered. Measurement at 24 \pm 4 hours after test conclusion.
9.2	Temperature Cycling	JESD22 Method JA-104	1000 cycles (-40°C to 125°C) Note: If 85°C part the 1000 cycles will be at that temperature rating. Measurement at 24 \pm 4 hours after test conclusion. 30min maximum dwell time at each temperature extreme. 1 min. maximum transition time.
9.3	Biased Humidity	MIL-STD- 202 Method 103	1000 hours 85°C/85%RH. Rated VDD applied with 1 MW and inverter in parallel, 2X crystal CL capacitors between each crystal leg and GND. Measurement at 24 \pm 4 hours after test conclusion.
9.4	Operational Life	MIL-STD- 202 Method 108	Note: 1000 hrs @ 125°C. If 85°C part will be tested at that temperature. Rated VDD applied with 1 MW and inverter in parallel, 2X crystal CL capacitors between each crystal leg and GND. Measurement at 24 \pm 4 hours after test conclusion.
9.5	Terminal Strength (Leaded)	MIL-STD- 202 Method 211	Test leaded device lead integrity only. Conditions: A (227 g), C (227 g).
9.6	Resistance to Solvents	MIL-STD- 202 Method 215	Note: Also aqueous wash chemical - OKEM clean or equivalent. Do not use banned solvents.
9.7	Mechanical Shock	MIL-STD-202 Method 213	Figure 1 of Method 213. Condition C
9.8	Vibration	MIL-STD-202 Method 204	5g's for 20 minutes 12 cycles each of 3 orientations. Note: Use 8"X5" PCB .031" thick with 7 secure points on one 8" side and 2 secure points on corners of opposite sides. Parts mounted within 2" from any secure point. Test from 10-2000 Hz.
9.9	Resistance to Soldering Heat	MIL-STD-202 Method 210	Condition B No pre-heat of samples. Note: Single Wave solder - Procedure 1 with solder within 1.5 mm of device body for Leaded. Procedure 1 except 230°C and immerse only to level to cover terminals for SMD.
9.10	Solder ability	J-STD-002	For both Leaded & SMD. Electrical Test not required. Magnification 50 X. Conditions: Leaded: Method A @ 235°C, category 3. SMD: a) Method B, 4 hrs @ 155°C dry heat @ 235°C b) Method B @ 215°C category 3. c) Method D category 3 @ 260°C.
9.11	Flammability	UL-94	V-0 or V-1 Acceptable
9.12	Board Flex	AEC Q200-005	60 sec minimum holding time.
9.13	Terminal Strength(SMD)	AEC Q200-006	-

10. Cautions for use

(1) Soldering in mounting

In case of Solder paste and conductive glue contact product lid or product side face exception for product terminal it's possible to influence product characteristics.

Please be careful above contents.

(2) Automatic mounting machine use

Please use after affirmation that select the mounting machine model with a shock small if possible in the case of use of an automatic mounting machine, and it does not have breakage. There is a risk of a quartz crystal unit breakage occurring and not functioning normally by too much shock etc..

(3) Conformity of a circuit

In case of use of an oscillation circuit, please insert in a quartz crystal unit in series resistance 10 times as many as the standard value of equivalent in-series resistance, and confirm oscillating. Please remove resistance which inserted after the notes above-mentioned examination in the quartz crystal unit in series, and use it.

(4) After making the Quartz Crystal mount on a printed circuit board ,if it is required to devide the printed circuit board into another one, use it with attentive confirmation so that a warp cased by this dividing might not affect any damage. When designing a printed circuit board as well as handling the mounting As much as possible. The quartz crystal shall be passed through the reflow furnace. Then it shall be subjected to standard atmospheric conditions, after which cleaning shall be made.

11. Storage conditions

Storage at prolonged high temperature or low temperature and the storage by high humidity cause degradation of frequency accuracy, and degradation of soldering nature. Storage is performed at the temperature of 18-30 degrees C, and the humidity of 20-70 Percent in the state of packing, and a term is 6 months.

12. Manufacturing location

Kyocera Crystal Device Corporation / Japan(Yamagata)

Kyocera Crystal Device (Thailand) Co., Ltd / Thailand(Lamphun)

13. Quality Assurance

To be guaranteed by Kyocera Crystal Device Quality Assurance Division

14. Quality guarantee

When the failure by the responsibility of our company occurs clearly after delivery within 1 year, a substitute article etc. is appropriated gratuitously and this is guaranteed. However, when passing 1 year after delivery, there is a case where I am allowed to consider as onerous repair after both consultation.

15. Others

When any questions and opinions are in the written matter of these delivery specifications, I will ask connection of you from the our company issue day within 45 days. In a connection no case, a written matter is consented to it and employed within a term.

Looking for pricing, stock, or lifecycle information?

Click below to explore more details on WIN SOURCE:

- ⊖ [View CX8045GA04000H0PST03 on WIN SOURCE](#)
- ⊖ [AVX Corp/Kyocera Corp Information](#)

Optimize Your Supply Chain with WIN SOURCE Solutions

- ✓ Global Sourcing Solution
- ✓ Obsolete Management
- ✓ Cost Control Management
- ✓ Shortage Management
- ✓ Alternative Solution
- ✓ Excess Inventory Management