



THE DATASHEET OF
2297507



Motor management - EMM 3-230AC/500AC-IFS - 2297507

Please be informed that the data shown in this PDF Document is generated from our Online Catalog. Please find the complete data in the user's documentation. Our General Terms of Use for Downloads are valid (<http://phoenixcontact.com/download>)



Electronic motor management for operation with external current transformer- active power measurement for overload and underload monitoring of motors and systems for optimum protection for all performance classes. Freely parameterizable switching and signaling thresholds.

The figure shows version: EMM 3-24DC/500AC-16

Product Features

- Optional connection to INTERFACE system and PROFIBUS-GATEWAY-IFS via TBUS
- Digital outputs control external switching elements
- Freely parameterizable signaling or switching thresholds



Key commercial data

Packing unit	1 pc
Weight per Piece (excluding packing)	444.0 GRM
Custom tariff number	85371099
Country of origin	Germany

Technical data

Note

Utilization restriction	EMC: class A product, see manufacturer's declaration in the download area
-------------------------	---

Dimensions

Width	22.5 mm
Height	99 mm
Depth	114.5 mm

Ambient conditions

Ambient temperature (operation)	-25 °C ... 70 °C
Ambient temperature (storage/transport)	-25 °C ... 70 °C

Motor management - EMM 3-230AC/500AC-IFS - 2297507

Technical data

Ambient conditions

Degree of protection	IP20
----------------------	------

Input data

Input name	Device supply
Rated control supply voltage U_S	230 V AC
Voltage range with reference to U_S	0.4 ... 1.1
Rated control supply current I_S	10 mA
Switching threshold "0" signal, voltage	48 V AC
Switching threshold "1" signal voltage	96 V AC
Operating voltage display	Green LED
Status display	LED yellow right rotation (R), LED yellow left rotation (L), LED green data communication
Indication	Red LED
Input name	Digital inputs (IN1 - IN4)
Rated actuating voltage U_C	230 V AC
Rated actuating current I_C	3.5 mA
Input name	Voltage measuring input V1, V2, V3
Input voltage range	42 V AC ... 575 V AC
Typical input current at U_N	< 0.5 mA
Input name	Current measuring input L1/T1, L2/T2, L3/T3
Typical input current at U_N	5 A (Secondary external converter)

Output data

Output name	Acknowledging contacts O1-O4
Note	The meaning of the acknowledgement outputs can be freely parameterized, see user manual
Number of outputs	4
Nominal output voltage	230 V AC (relay output/500 mA)
Continuous load current	500 mA

Output data, signaling contact

Designation	Current measurement
Measuring via	External push-through current transformers connected upstream
Basic accuracy	typ. 0.5 %
Designation	Voltage measurement/phase-to-neutral voltage
Voltage range	0 V AC ... 350 V AC (Phase-to-neutral voltage)
Basic accuracy	typ. 0.75 %
Designation	Power measurement
Basic accuracy	typ. 2 %

Motor management - EMM 3-230AC/500AC-IFS - 2297507

Technical data

Connection data

Connection method	Screw connection
Conductor cross section solid min.	0.14 mm ²
Conductor cross section solid max.	2.5 mm ²
Conductor cross section stranded min.	0.14 mm ²
Conductor cross section stranded max.	2.5 mm ²
Conductor cross section AWG/kcmil min.	26
Conductor cross section AWG/kcmil max	12

General

Test voltage input/output	8 kV
Mounting position	Vertical (horizontal DIN rail)
Assembly instructions	In rows with zero spacing
Operating mode	100% operating factor
Designation	Low voltage switching device
Standards/regulations	EN 60947
	EN 60947-4-2
Designation	Power station requirements
Standards/regulations	DWR 1300 / ZXX01/DD/7080.8d
Designation	Noise immunity
Standards/regulations	EN 61000-6-2
	EN 61000-6-3
	EN 61000-6-4
Rated surge voltage / insulation	6 kV/safe isolation
Rated insulation voltage	500 V
Pollution degree	2
Surge voltage category	III

Classifications

eCl@ss

eCl@ss 4.0	27371102
eCl@ss 4.1	27371102
eCl@ss 5.0	27371601
eCl@ss 5.1	27371601
eCl@ss 6.0	27371601
eCl@ss 7.0	27371601
eCl@ss 8.0	27371601

Motor management - EMM 3-230AC/500AC-IFS - 2297507

Classifications

ETIM

ETIM 2.0	EC000066
ETIM 3.0	EC000066
ETIM 4.0	EC000066
ETIM 5.0	EC001437

UNSPSC

UNSPSC 6.01	30211915
UNSPSC 7.0901	39121514
UNSPSC 11	39121514
UNSPSC 12.01	39121514
UNSPSC 13.2	39121514

Approvals

Approvals

Approvals

UL Listed / cUL Listed / cULus Listed

Ex Approvals

ATEX

Approvals submitted

Approval details

UL Listed 

cUL Listed 
--

Motor management - EMM 3-230AC/500AC-IFS - 2297507

Approvals



Drawings

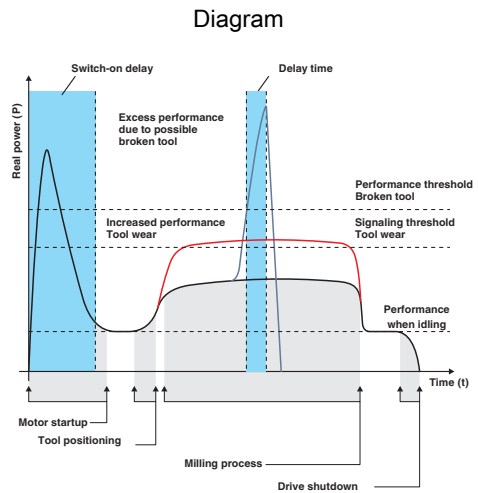
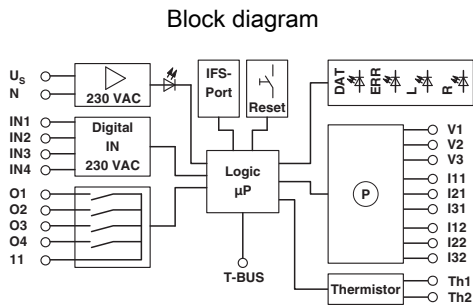

Status monitoring: machine tool for milling

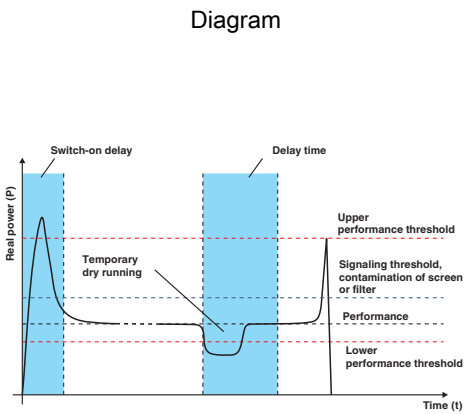

Status monitoring: air bubbles in motor-operated pumps

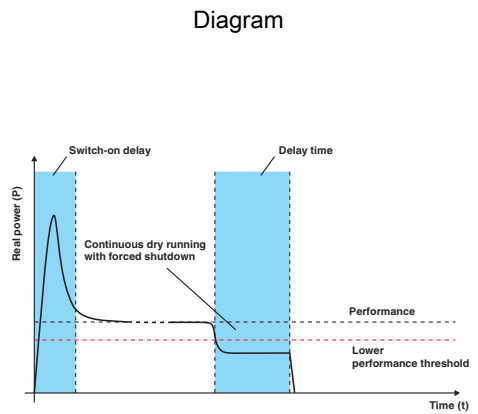

Status monitoring: dry run in motor-operated pumps

Motor management - EMM 3-230AC/500AC-IFS - 2297507

Connection diagram

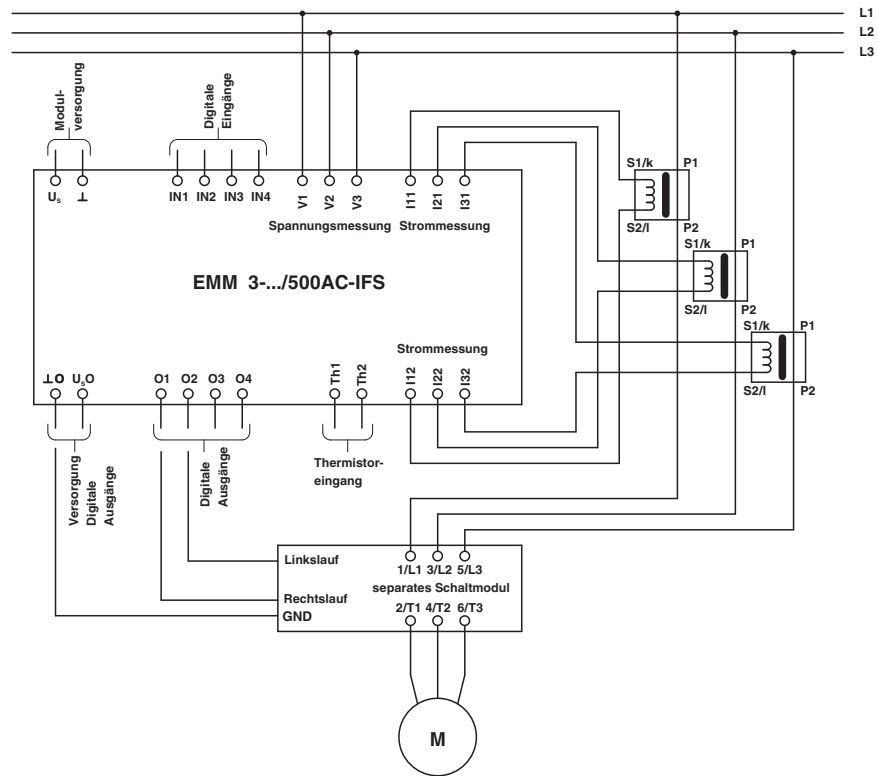

Motor management - EMM 3-230AC/500AC-IFS - 2297507

Connection diagram

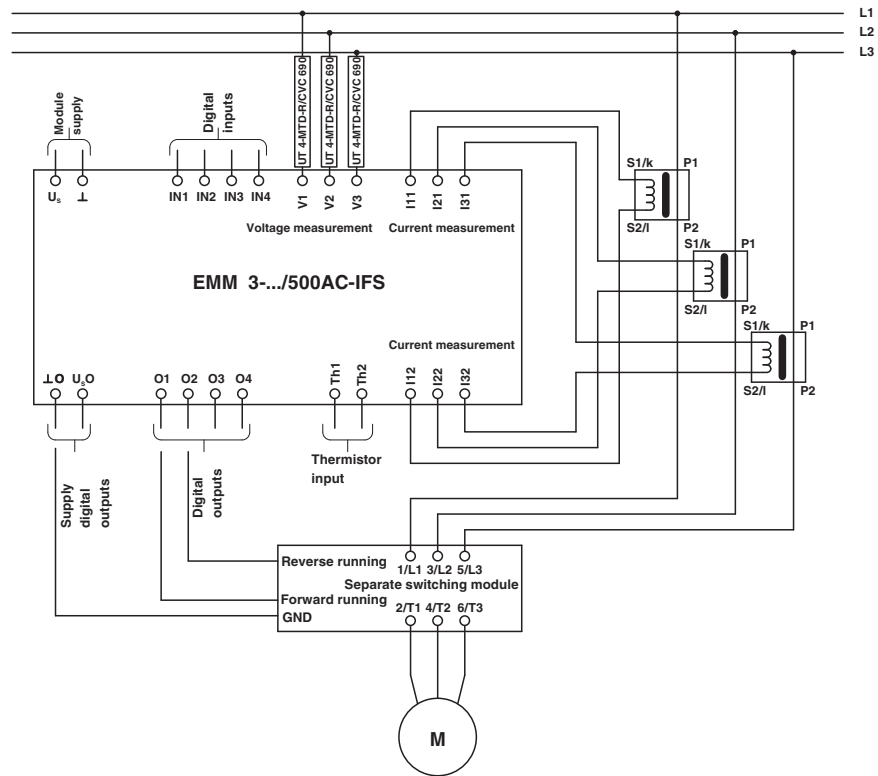

EMM 3-.../500AC-IFS with connected CONTACTRON VOLTAGE CONVERTER

Looking for pricing, stock, or lifecycle information?

Click below to explore more details on WIN SOURCE:

 [View 2297507 on WIN SOURCE](#)

 [Phoenix Contact Information](#)

Optimize Your Supply Chain with WIN SOURCE Solutions

-  Global Sourcing Solution
-  Obsolete Management
-  Cost Control Management
-  Shortage Management
-  Alternative Solution
-  Excess Inventory Management