



# THE DATASHEET OF SR2C-B4



## Installation Instructions for the SR2 Series Hall-Effect Position Sensors

ISSUE 2

PK 88581

### ELECTRICAL AND MAGNETIC SPECIFICATIONS

		SR2C-B4
Supply Voltage, VDC		4.5 to 24
Supply Current, mA max.		10
Output Type		NPN
Output Voltage, max.		0.40 V
Output Current, mA max.		40
Magnetic Type*		Unipolar
-40 to 100°C	Max. Op.	220
	Min. Rel.	50
	Min. Diff.	8
+25°C	Typ. Op.	150
	Typ. Rel.	80
	Typ. Diff.	10

\* A unipolar sensor has a plus maximum operate point and a plus minimum release point. One magnetic pole (south) is required to operate and release a unipolar sensor.

### ABSOLUTE MAXIMUM RATINGS\*

Parameters	4.5 to 24 VDC Circuit
Supply Voltage (Vs)	-1.0 to +25 VDC
Voltage Externally Applied to Output	-0.5 V max. (ON or OFF) +25 V max. (OFF only)
Output Current	40 mA
Temperature, Operate and Storage	-40 to +100°C (-40 to +212°F)
Magnetic Flux	No limit. Circuit cannot be damaged by magnetic overdrive.

\* Absolute maximum ratings are the extreme limits that the device will withstand without damage to the device. However, the electrical and magnetic characteristics are not guaranteed as the maximum limits (above recommended operating conditions) are approached, nor will the device necessarily operate at absolute maximum rating.

### LEADWIRE COLOR CODE

Red	Vs (+)
Black	Ground (-)
White	Output (Digital)

### NOTICE

**Do not** reverse supply voltage polarity.

**Do not** exceed maximum ratings.

### MOUNTING DIMENSIONS (for reference only)

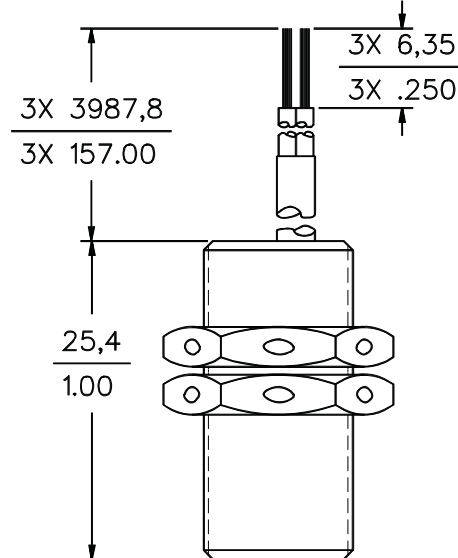

### 1SR15 Mounting Bracket

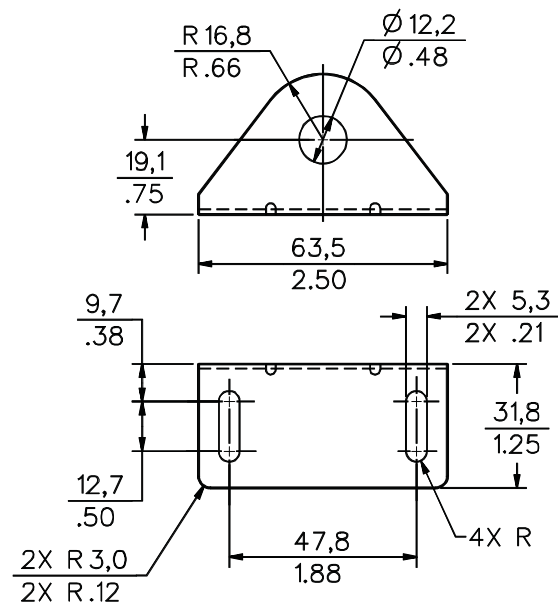

## TROUBLESHOOTING

If sensor does not operate, follow these steps:

1. Make certain wiring is correct (load must be connected).
2. Measure supply voltage across the Red (+) and Black (-) leads to verify that proper supply voltage is present.
3. Connect positive lead of voltmeter to White (output) lead, and negative voltmeter lead to Black (-) lead. With magnet removed (or north pole present), the reading should equal  $V_s$ .
4. When the magnet (south pole) moves toward sensor face (beyond operating point), the sensor output should be 0.40 VDC.

## WARRANTY/REMEDY

Honeywell warrants goods of its manufacture as being free of defective materials and faulty workmanship. Commencing with date of shipment, Honeywell's warranty runs for 18 months. If warranted goods are returned to Honeywell during that period of coverage, Honeywell will repair or replace without charge those items it finds defective. The foregoing is Buyer's sole remedy and is **in lieu of all other warranties, expressed or implied, including those of merchantability and fitness for a particular purpose.**

For application assistance, current specifications, pricing or name of the nearest Authorized Distributor, contact a nearby sales office. Or call:

1-800-537-6945 USA

1-416-293-8111 Canada

1-815-235-6847 International

<http://www.honeywell.sensing.com>

[info.sc@honeywell.com](mailto:info.sc@honeywell.com)

Specifications not affecting form, fit or function may change without notice. The information we supply is believed to be accurate and reliable as of this printing. However, we assume no responsibility for its use.

While we provide application assistance, personally and through our literature, it is up to the customer to determine the suitability of the product in the application.

## CURRENT SINKING OUTPUTS

(Current flow through load into sensor.) Output terminal is open collector. In the unoperated condition ( $I_L = 0$ ), the output voltage is normally high.

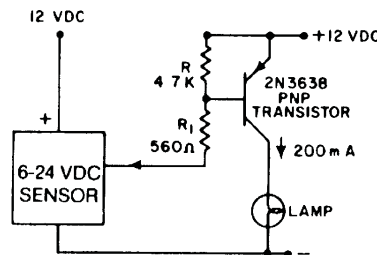
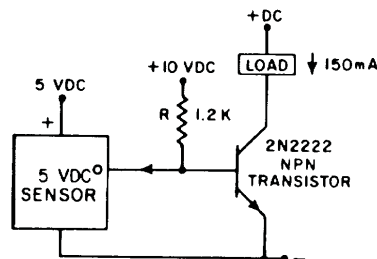
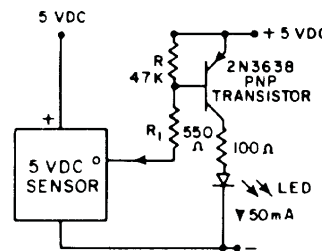
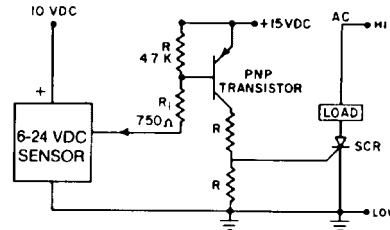

# Honeywell

Sensing and Control

Honeywell

11 West Spring Street

Freeport, Illinois 61032



Printed with Soy Ink  
on 50% Recycled Paper

PK 88581-2 0303 Printed in USA

[www.honeywell.com/sensing](http://www.honeywell.com/sensing)

## Looking for pricing, stock, or lifecycle information?

Click below to explore more details on WIN SOURCE:

 [View SR2C-B4 on WIN SOURCE](#)

 [Honeywell Information](#)

## Optimize Your Supply Chain with WIN SOURCE Solutions

-  Global Sourcing Solution
-  Obsolete Management
-  Cost Control Management
-  Shortage Management
-  Alternative Solution
-  Excess Inventory Management