



**THE DATASHEET OF  
CY2291FX**





# Three-PLL General Purpose EPROM Programmable Clock Generator

## Features

- Three integrated phase-locked loops
- EPROM programmability
- Factory-programmable (CY2291) or field-programmable (CY2291F) device options
- Low-skew, low-jitter, high-accuracy outputs
- Power-management options (Shutdown, OE, Suspend)
- Frequency select option
- Smooth slewing on CPUCLK
- Configurable 3.3 V or 5 V operation
- 20-pin SOIC Package

## Functional Description

The CY2291 is a third-generation family of clock generators. The CY2291 is upwardly compatible with the industry standard ICD2023 and ICD2028 and continues their tradition by providing a high level of customizable features to meet the diverse clock synchronous systems.

All parts provide a highly configurable set of close for PC motherboard applications. Each of four configurable clock outputs (CLKA-CLKD) can be assigned 1 of 30 frequencies in any combination. Multiple outputs configured for the same or related[3] frequencies have low (<500 ps) skew, in effect providing on-chip buffering for heavily loaded signals.

The CY2291 can be configured for either 5 V or 3.3 V operation. The internal ROM tables use EPROM technology, allowing full customization of output frequencies. The reference oscillator has been designed for 10 MHz to 25 MHz crystals, providing additional flexibility. No external components are required with this crystal. Alternatively, an external reference clock of frequency between 1 MHz to 30 MHz can be used. Customers using the 32 kHz oscillator must connect a 10-MΩ resistor in parallel with the 32 kHz crystal.

For a complete list of related documentation, click [here](#).

## Selection Guide

Part Number	Outputs	Input Frequency Range	Output Frequency Range	Specifics
CY2291	8	10 MHz–25 MHz (external crystal) 1 MHz–30 MHz (reference clock)	76.923 kHz–100 MHz (5 V) 76.923 kHz–80 MHz (3.3 V)	Factory programmable Commercial temperature
CY2291F	8	10 MHz–25 MHz (external crystal) 1 MHz–30 MHz (reference clock)	76.923 kHz–90 MHz (5 V) 76.923 kHz–66.6 MHz (3.3 V)	Field programmable Commercial temperature

**Logic Block Diagram**

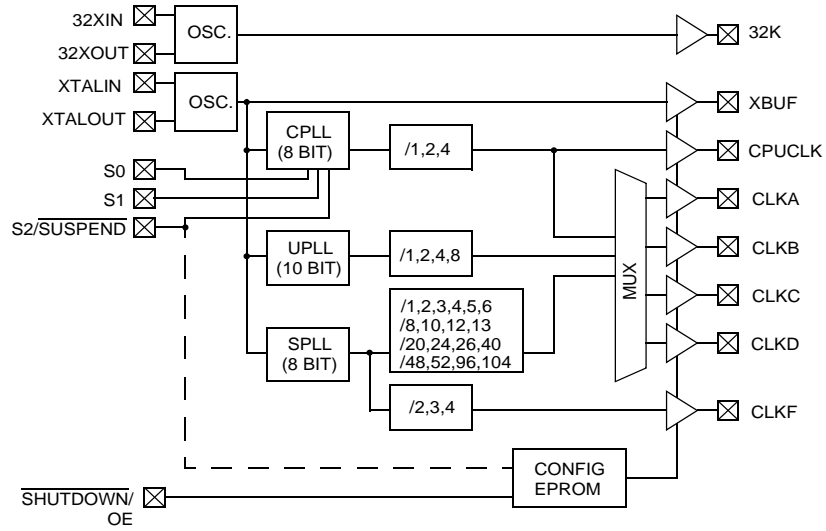

## Contents

<b>Pinouts</b> .....	<b>4</b>	<b>Ordering Information</b> .....	<b>11</b>
<b>Pin Definitions</b> .....	<b>4</b>	Possible Configurations .....	11
<b>Functional Overview</b> .....	<b>5</b>	Ordering Code Definitions .....	11
Output Configuration .....	5	<b>Packaging Information</b> .....	<b>12</b>
Power Saving Features .....	5	Package Characteristics .....	12
CyClocks Software .....	5	Package Diagram .....	12
Cypress FTG Programmer .....	5	<b>Acronyms</b> .....	<b>13</b>
Custom Configuration Request Procedure .....	5	<b>Document Conventions</b> .....	<b>13</b>
<b>Maximum Ratings</b> .....	<b>6</b>	Units of Measure .....	13
<b>Operating Conditions</b> .....	<b>6</b>	<b>Document History Page</b> .....	<b>14</b>
<b>Test Circuit</b> .....	<b>6</b>	<b>Sales, Solutions, and Legal Information</b> .....	<b>16</b>
<b>Electrical Characteristics</b> .....	<b>7</b>	Worldwide Sales and Design Support .....	16
<b>Electrical Characteristics</b> .....	<b>7</b>	Products .....	16
<b>Switching Characteristics</b> .....	<b>8</b>	PSoC® Solutions .....	16
<b>Switching Characteristics</b> .....	<b>9</b>	Cypress Developer Community .....	16
<b>Switching Waveforms</b> .....	<b>10</b>	Technical Support .....	16

## Pinouts

**Figure 1. 20-pin SOIC pinout**

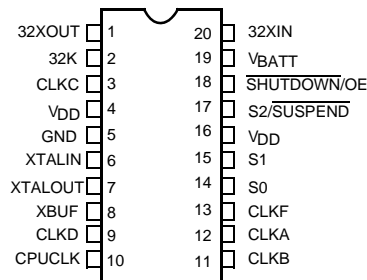

## Pin Definitions

Name	Pin Number	Description
32XOUT <sup>[1]</sup>	1	32.768-kHz crystal feedback.
32K	2	32.768-kHz output (always active if VBATT is present).
CLKC	3	Configurable clock output C.
VDD	4, 16	Voltage supply.
GND	5	Ground.
XTALIN <sup>[2]</sup>	6	Reference crystal input or external reference clock input.
XTALOUT <sup>[2, 3]</sup>	7	Reference crystal feedback.
XBUF	8	Buffered reference clock output.
CLKD	9	Configurable clock output D.
CPUCLK	10	CPU frequency clock output.
CLKB	11	Configurable clock output B.
CLKA	12	Configurable clock output A.
CLKF	13	Configurable clock output F.
S0	14	CPU clock select input, bit 0.
S1	15	CPU clock select input, bit 1.
S2/SUSPEND	17	CPU clock select input, bit 2. Optionally enables suspend feature when LOW.
SHUTDOWN/OE	18	Places outputs in three-state <sup>[4]</sup> condition and shuts down chip when LOW. Optionally, only places outputs in three-state <sup>[4]</sup> condition and does not shut down chip when LOW.
VBATT <sup>[1]</sup>	19	Battery supply for 32.768-kHz circuit.
32XIN <sup>[1]</sup>	20	32.768 kHz crystal input.

### Notes

1. If power is applied to VBATT, then a watch crystal (32.768 KHz) must be connected to the 32XIN and 32XOUT pins.
2. For best accuracy, use a parallel-resonant crystal,  $C_{LOAD} \approx 17$  pF or 18 pF.
3. Float XTALOUT pin if XTALIN is driven by reference clock (as opposed to crystal).
4. The CY2291 has weak pull downs on all outputs (except 32K). Hence, when a three-state condition is forced on the outputs, the output pins are pulled LOW.

## Functional Overview

### Output Configuration

The CY2291 has five independent frequency sources on-chip. These are the 32-kHz oscillator, the reference oscillator, and three Phase-locked loops (PLLs). Each PLL has a specific function. The System PLL (SPLL) drives the CLKF output and provides fixed output frequencies on the configurable outputs. The SPLL offers the most output frequency divider options. The CPU PLL (CPLL) is controlled by the select inputs (S0–S2) to provide eight user-selectable frequencies with smooth slewing between frequencies. The Utility PLL (UPLL) provides the most accurate clock. It is often used for miscellaneous frequencies not provided by the other frequency sources.

All configurations are EPROM programmable, providing short sample and production lead times.

### Power Saving Features

The SHUTDOWN/OE input three-states the outputs when pulled LOW (the 32-kHz clock output is not affected). If system shutdown is enabled, a LOW on this pin also shuts off the PLLs, counters, the reference oscillator, and all other active components. The resulting current on the  $V_{DD}$  pins are less than 50  $\mu\text{A}$  plus 15  $\mu\text{A}$  max. for the 32-kHz subsystem and is typically 10  $\mu\text{A}$ . After leaving shutdown mode, the PLLs have to re-lock. All outputs except 32K have a weak pull down so that the outputs do not float when three-stated.<sup>[4]</sup>

The S2/SUSPEND input can be configured to shut down a customizable set of outputs and/or PLLs, when LOW. All PLLs and any of the outputs except 32K can be shut off in nearly any combination. The only limitation is that if a PLL is shut off, all outputs derived from it must also be shut off. Suspending a PLL shuts off all associated logic, while suspending an output simply forces a three-state condition<sup>[3]</sup>.

The CPUCLK can slew (transition) smoothly between 8 MHz and the maximum output frequency (100 MHz at 5V/80 MHz at 3.3 V for commercial temp. parts). This feature is extremely useful in “Green” PC and laptop applications, where reducing the frequency of operation can result in considerable power savings. This feature meets all 486 and Pentium<sup>®</sup> processor slewing requirements.

### CyClocks Software

CyClocks™ is an easy-to-use application that allows you to configure any one of the EPROM programmable clocks offered by Cypress. You may specify the input frequency, PLL and output frequencies, and different functional options. Please note the output frequency ranges in this data sheet when specifying them in CyClocks to ensure that you stay within the limits. CyClocks also has a power calculation feature that allows you to see the power consumption of your specific configuration. CyClocks is a sub-application within the CyberClocks™ software. You can download a copy of CyberClocks for free on Cypress's web site at [www.cypress.com](http://www.cypress.com).

### Cypress FTG Programmer

The Cypress frequency timing generator (FTG) Programmers is a portable programmer designed to custom program our family of EPROM field programmable clock devices. The FTG programmers connect to a PC serial port and allow users of CyClocks software to quickly and easily program any of the CY2291F, CY2292F, CY2071AF, and CY2907F devices. The ordering code for the Cypress FTG Programmer is CY3670.

### Custom Configuration Request Procedure

The CY229x are EPROM-programmable devices that may be configured in the factory or in the field by a Cypress Field Application Engineer (FAE). The output frequencies requested are matched as closely as the internal PLL divider and multiplier options allow. All custom requests must be submitted to your local Cypress FAE or sales representative. The method to use to request custom configurations is:

Use CyClocks™ software. This software automatically calculates the output frequencies that can be generated by the CY229x devices and provides a print-out of final pinout which can be submitted (in electronic or print format) to your local FAE or sales representative. The CyClocks software is available free of charge from the Cypress web site (<http://www.cypress.com>) or from your local sales representative.

Once the custom request has been processed you receive a part number with a 3-digit extension (for example, CY2292SC-128) specific to the frequencies and pinout of your device. This is the part number used for samples requests and production orders.

### Maximum Ratings

Exceeding maximum ratings may shorten the useful life of the device. These user guidelines are not tested.

Supply voltage ..... -0.5 V to + 7.0 V  
 DC input voltage ..... -0.5 V to + 7.0 V

Storage temperature ..... -65 °C to +150 °C  
 Maximum soldering temperature (10 sec) ..... 260 °C  
 Junction temperature ..... 150 °C  
 Package power dissipation ..... 750 mW  
 Static discharge voltage  
 (per MIL-STD-883, Method 3015) ..... ≥ 2000 V

### Operating Conditions

Parameter <sup>[5]</sup>	Description	Part Numbers	Min	Max	Unit
V <sub>DD</sub>	Supply voltage, 5.0 V operation	All	4.5	5.5	V
V <sub>DD</sub>	Supply voltage, 3.3 V operation	All	3.0	3.6	V
V <sub>BATT</sub> <sup>[1]</sup>	Battery backup voltage	All	2.0	5.5	V
T <sub>A</sub>	Commercial operating temperature, ambient	CY2291/CY2291F	0	+70	°C
C <sub>LOAD</sub>	Max. load capacitance 5.0 V operation	All	–	25	pF
C <sub>LOAD</sub>	Max. load capacitance 3.3 V operation	All	–	15	pF
f <sub>REF</sub>	External reference crystal	All	10.0	25.0	MHz
	External reference clock <sup>[6, 7, 8]</sup>	All	1	30	MHz
t <sub>PU</sub>	Power-up time for all VDDs to reach minimum specified voltage (power ramps must be monotonic)		0.05	50	ms

### Test Circuit

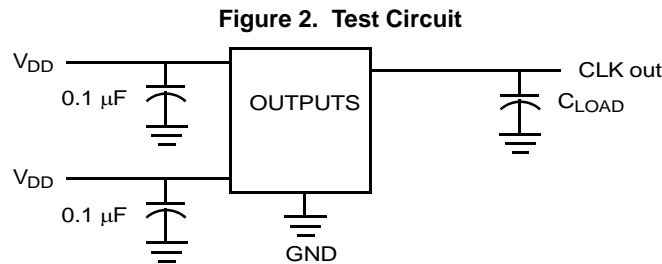

**Notes**

5. Electrical parameters are guaranteed by design with these operating conditions, unless otherwise noted.
6. External input reference clock must have a duty cycle between 40% and 60%, measured at V<sub>DD</sub>/2.
7. Refer to the White Paper “Crystal Parameters Recommendation for Cypress Frequency Synthesizers” for information on AC-coupling the external input reference clock.
8. The oscillator circuit is optimized for a crystal reference and for external reference clocks up to 20 MHz. For external reference clocks above 20 MHz, it is recommended that a 150Ω pull up resistor to V<sub>DD</sub> be connected to the XTALOUT pin.

## Electrical Characteristics

Commercial, 5.0 V

Parameter	Description	Conditions	Min	Typ	Max	Unit	
V <sub>OH</sub>	HIGH-level output voltage	I <sub>OH</sub> = 4.0 mA	2.4	–	–	V	
V <sub>OL</sub>	LOW-level output voltage	I <sub>OL</sub> = 4.0 mA	–	–	0.4	V	
V <sub>OH-32</sub>	32.768-kHz HIGH-level output voltage	I <sub>OH</sub> = 0.5 mA	V <sub>BATT</sub> × 0.5	–	–	V	
V <sub>OL-32</sub>	32.768-kHz LOW-level output voltage	I <sub>OL</sub> = 0.5 mA	–	–	0.4	V	
V <sub>IH</sub>	HIGH-level input voltage <sup>[9]</sup>	Except crystal pins	2.0	–	–	V	
V <sub>IL</sub>	LOW-level input voltage <sup>[9]</sup>	Except crystal pins	–	–	0.8	V	
I <sub>IH</sub>	Input HIGH current	V <sub>IN</sub> = V <sub>DD</sub> – 0.5 V	–	<1	10	μA	
I <sub>IL</sub>	Input LOW current	V <sub>IN</sub> = +0.5 V	–	<1	10	μA	
I <sub>OZ</sub>	Output leakage current	Three-state outputs	–	–	250	μA	
I <sub>DD</sub>	V <sub>DD</sub> supply current commercial <sup>[10]</sup>	V <sub>DD</sub> = V <sub>DD</sub> Max., 5 V operation	–	75	100	mA	
I <sub>DDS</sub>	V <sub>DD</sub> power supply current in shutdown mode <sup>[10]</sup>	Shutdown active, excluding V <sub>BATT</sub>	CY2291 / CY2291F	–	10	50	μA
I <sub>BATT</sub>	V <sub>BATT</sub> power supply current	V <sub>BATT</sub> = 3.0 V	–	5	15	μA	

## Electrical Characteristics

Commercial, 3.3 V

Parameter	Description	Conditions	Min	Typ	Max	Unit	
V <sub>OH</sub>	HIGH-level output voltage	I <sub>OH</sub> = 4.0 mA	2.4	–	–	V	
V <sub>OL</sub>	LOW-level output voltage	I <sub>OL</sub> = 4.0 mA	–	–	0.4	V	
V <sub>OH-32</sub>	32.768-kHz HIGH-level output voltage	I <sub>OH</sub> = 0.5 mA	V <sub>BATT</sub> 0.5	–	–	V	
V <sub>OL-32</sub>	32.768-kHz LOW-level output voltage	I <sub>OL</sub> = 0.5 mA	–	–	0.4	V	
V <sub>IH</sub>	HIGH-level input voltage <sup>[9]</sup>	Except crystal pins	2.0	–	–	V	
V <sub>IL</sub>	LOW-level input voltage <sup>[9]</sup>	Except crystal pins	–	–	0.8	V	
I <sub>IH</sub>	Input HIGH current	V <sub>IN</sub> = V <sub>DD</sub> – 0.5 V	–	<1	10	μA	
I <sub>IL</sub>	Input LOW current	V <sub>IN</sub> = +0.5 V	–	<1	10	μA	
I <sub>OZ</sub>	Output leakage current	Three-state outputs	–	–	250	μA	
I <sub>DD</sub>	V <sub>DD</sub> supply current <sup>[10]</sup> commercial	V <sub>DD</sub> = V <sub>DD</sub> Max., 3.3 V operation	–	50	65	mA	
I <sub>DDS</sub>	V <sub>DD</sub> power supply current in shutdown mode <sup>[10]</sup>	Shutdown active, excluding V <sub>BATT</sub>	CY2291 / CY2291F	–	10	50	μA
I <sub>BATT</sub>	V <sub>BATT</sub> power supply current	V <sub>BATT</sub> = 3.0 V	–	5	15	μA	

**Notes**

9. Xtal inputs have CMOS thresholds.

 10. Load = Max., V<sub>IN</sub> = 0 V or V<sub>DD</sub>; Typical (–104) configuration, CPUCLK = 66 MHz. Other configurations vary. Power can be approximated by the following formula (multiply by 0.65 for 3 V operation): I<sub>DD</sub> = 10 + (0.06 × (F<sub>CPLL</sub> + F<sub>UPLL</sub> + (2 × F<sub>SPLL</sub>))) + (0.27 × (F<sub>CLKA</sub> + F<sub>CLKB</sub> + F<sub>CLKC</sub> + F<sub>CLKD</sub> + F<sub>CPULCK</sub> + F<sub>CLKF</sub> + F<sub>XBUF</sub>)).

## Switching Characteristics

Commercial, 5.0 V

Parameter	Name	Description	Min	Typ	Max	Unit	
t <sub>1</sub>	Output period	Clock output range, 5 V operation	CY2291	10 (100 MHz)	–	13000 (76.923 kHz)	ns
			CY2291F	11.1 (90 MHz)	–	13000 (76.923 kHz)	ns
	Output duty cycle <sup>[11]</sup>	Duty cycle for outputs, defined as $t_2 \div t_1$ <sup>[12]</sup> f <sub>OUT</sub> ≥ 66 MHz	40%	50%	60%	–	
		Duty cycle for outputs, defined as $t_2 \div t_1$ <sup>[12]</sup> f <sub>OUT</sub> < 66 MHz	45%	50%	55%	–	
t <sub>3</sub>	Rise time	Output clock rise time <sup>[13]</sup>	–	3	5	ns	
t <sub>4</sub>	Fall time	Output clock fall time <sup>[13]</sup>	–	2.5	4	ns	
t <sub>5</sub>	Output disable time	Time for output to enter three-state mode after SHUTDOWN/OE goes LOW	–	10	15	ns	
t <sub>6</sub>	Output enable time	Time for output to leave three-state mode after SHUTDOWN/OE goes HIGH	–	10	15	ns	
t <sub>7</sub>	Skew	Skew delay between any identical or related outputs <sup>[12, 14]</sup>	–	< 0.25	0.5	ns	
t <sub>8</sub>	CPUCLK Slew	Frequency transition rate	1.0	–	20.0	MHz/ms	
t <sub>9A</sub>	Clock jitter <sup>[15]</sup>	Peak-to-peak period jitter (t <sub>9A</sub> Max. – t <sub>9A</sub> min.), % of clock period (f <sub>OUT</sub> ≤ 4 MHz)	–	< 0.5	1	%	
t <sub>9B</sub>	Clock jitter <sup>[15]</sup>	Peak-to-peak period jitter (t <sub>9B</sub> Max. – t <sub>9B</sub> min.) (4 MHz ≤ f <sub>OUT</sub> ≤ 16 MHz)	–	< 0.7	1	ns	
t <sub>9C</sub>	Clock jitter <sup>[15]</sup>	Peak-to-peak period jitter (16 MHz < f <sub>OUT</sub> ≤ 50 MHz)	–	< 400	500	ps	
t <sub>9D</sub>	Clock jitter <sup>[15]</sup>	Peak-to-peak period jitter (f <sub>OUT</sub> > 50 MHz)	–	< 250	350	ps	
t <sub>10A</sub>	Lock time for CPLL	Lock Time from Power-up	–	< 25	50	ms	
t <sub>10B</sub>	Locktime for UPLL and SPLL	Lock Time from Power-up	–	< 0.25	1	ms	
	Slew limits	CPU PLL Slew limits	CY2291	8	–	100	MHz
			CY2291F	8	–	90	MHz

**Notes**

11. XBUF duty cycle depends on XTALIN duty cycle.

12. Measured at 1.4 V.

13. Measured between 0.4V and 2.4 V.

14. CLKF is not guaranteed to be in phase with CLKA-D, even if it is referenced off the same PLL.

 15. Jitter varies with configuration. All standard configurations sample tested at the factory conform to this limit. For more information on jitter, refer to the White Paper: ["Datasheet Jitter Specifications for Cypress Timing Products"](#).

## Switching Characteristics

Commercial, 3.3 V

Parameter	Name	Description	Min	Typ	Max	Unit	
t <sub>1</sub>	Output period	Clock output range, 3.3 V operation	CY2291	12.5 (80 MHz)	–	13000 (76.923 kHz)	ns
			CY2291F	15 (66.6 MHz)	–	13000 (76.923 kHz)	ns
	Output duty cycle <sup>[16]</sup>	Duty cycle for outputs, defined as $t_2 \div t_1$ <sup>[17]</sup> f <sub>OUT</sub> ≥ 66 MHz	40%	50%	60%	–	
			Duty cycle for outputs, defined as $t_2 \div t_1$ <sup>[17]</sup> f <sub>OUT</sub> < 66 MHz	45%	50%	55%	–
t <sub>3</sub>	Rise time	Output clock rise time <sup>[18]</sup>	–	3	5	ns	
t <sub>4</sub>	Fall time	Output clock fall time <sup>[18]</sup>	–	2.5	4	ns	
t <sub>5</sub>	Output disable time	Time for output to enter <u>three-state mode</u> after SHUTDOWN/OE goes LOW	–	10	15	ns	
t <sub>6</sub>	Output enable time	Time for output to leave <u>three-state mode</u> after SHUTDOWN/OE goes HIGH	–	10	15	ns	
t <sub>7</sub>	Skew	Skew delay between any identical or related outputs <sup>[17, 19]</sup>	–	< 0.25	0.5	ns	
t <sub>8</sub>	CPUCLK Slew	Frequency transition rate	1.0	–	20.0	MHz/ms	
t <sub>9A</sub>	Clock jitter <sup>[20]</sup>	Peak-to-peak period jitter (t <sub>9A</sub> Max. – t <sub>9A</sub> min.), % of clock period (f <sub>OUT</sub> ≤ 4 MHz)	–	< 0.5	1	%	
t <sub>9B</sub>	Clock jitter <sup>[20]</sup>	Peak-to-peak period jitter (t <sub>9B</sub> Max. – t <sub>9B</sub> min.) (4 MHz ≤ f <sub>OUT</sub> ≤ 16 MHz)	–	< 0.7	1	ns	
t <sub>9C</sub>	Clock jitter <sup>[20]</sup>	Peak-to-peak period jitter (16 MHz < f <sub>OUT</sub> ≤ 50 MHz)	–	< 400	500	ps	
t <sub>9D</sub>	Clock jitter <sup>[20]</sup>	Peak-to-peak period jitter (f <sub>OUT</sub> > 50 MHz)	–	< 250	350	ps	
t <sub>10A</sub>	Lock time for CPLL	Lock time from power-up	–	< 25	50	ms	
t <sub>10B</sub>	Lock time for UPLL and SPLL	Lock time from power-up	–	< 0.25	1	ms	
	Slew limits	CPU PLL slew limits	CY2291	8	–	80	MHz
			CY2291F	8	–	66.6	MHz

**Notes**

16. XBUF duty cycle depends on XTALIN duty cycle.

17. Measured at 1.4 V.

18. Measured between 0.4 V and 2.4 V.

19. CLKF is not guaranteed to be in phase with CLKA-D, even if it is referenced off the same PLL.

 20. Jitter varies with configuration. All standard configurations sample tested at the factory conform to this limit. For more information on jitter, refer to the White Paper: ["Datasheet Jitter Specifications for Cypress Timing Products"](#).

## Switching Waveforms

Figure 3. All Outputs, Duty Cycle and Rise/Fall Time

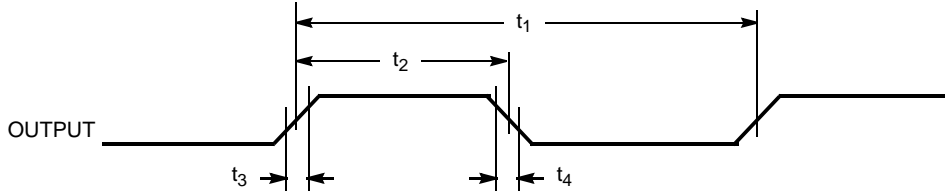

Figure 4. Output Three-State Timing <sup>[21]</sup>

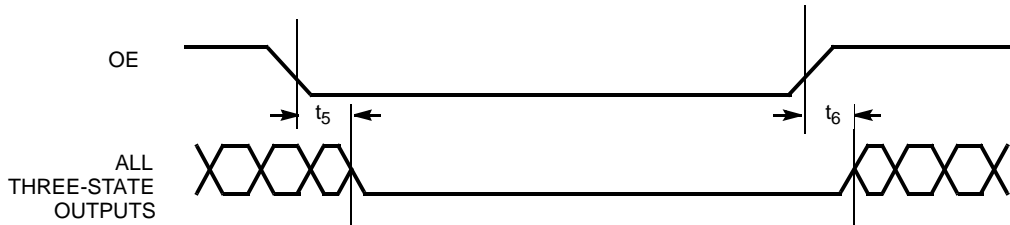

Figure 5. CLK Outputs Jitter and Skew

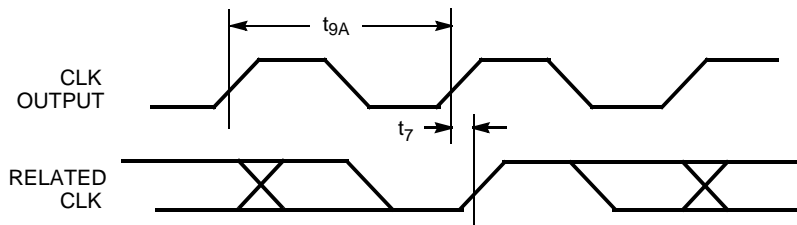
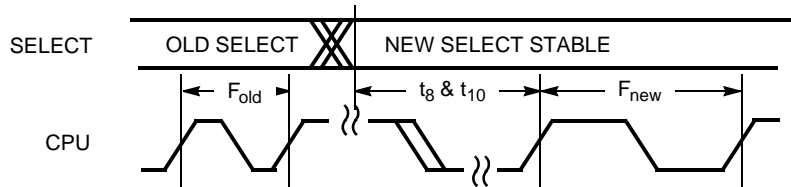

Figure 6. CPU Frequency Change



**Note**

21. The CY2291 has weak pull downs on all outputs (except 32K). Hence, when a three-state condition is forced on the outputs, the output pins are pulled LOW.

### Ordering Information

Ordering Code	Package Type	Operating Range	Operating Voltage
<b>Pb-free</b>			
CY2291FX	20-pin SOIC	Commercial	3.3 V or 5.0 V
CY2291FXT	20-pin SOIC – Tape and reel	Commercial	3.3 V or 5.0 V

Some product offerings are factory programmed customer specific devices with customized part numbers. The Possible Configurations table shows the available device types, but not complete part numbers. Contact your local Cypress FAE or Sales Representative for more information.

### Possible Configurations

Ordering Code	Package Type	Operating Range	Operating Voltage
<b>Pb-free</b>			
CY2291SXC-xxx	20-pin SOIC	Commercial	5.0 V
CY2291SXC-xxxT	20-pin SOIC – Tape and Reel	Commercial	5.0 V
CY2291SXL-xxx	20-pin SOIC	Commercial	3.3 V
CY2291SXL-xxxT	20-pin SOIC – Tape and Reel	Commercial	3.3 V

### Ordering Code Definitions

CY 2291 X X X X - xxx X

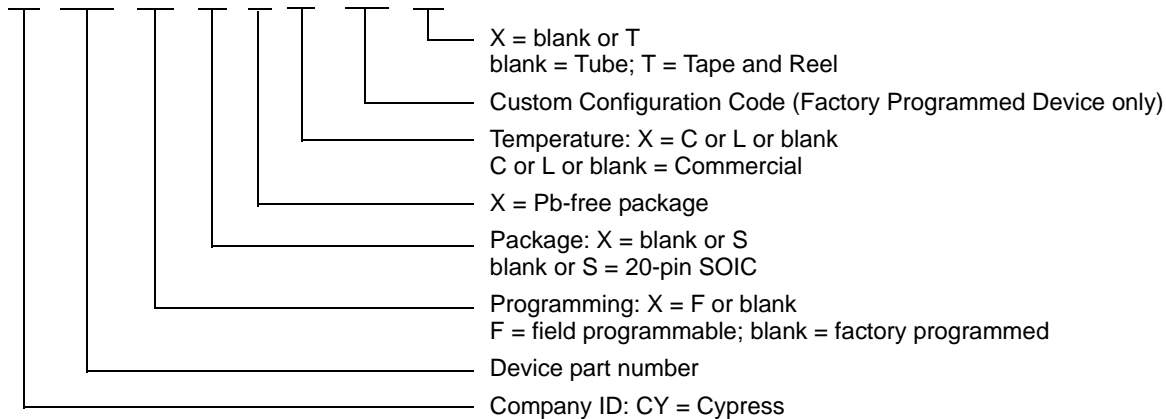

## Packaging Information

### Package Characteristics

Parameter <sup>[22]</sup>	Description	Test Conditions	20-pin SOIC	Unit
$\theta_{JA}$	Thermal resistance (junction to ambient)	Test conditions follow standard test methods and procedures for measuring thermal impedance, in accordance with EIA/JESD51.	73	°C/W
$\theta_{JC}$	Thermal resistance (junction to case)		38	°C/W

### Package Diagram

Figure 7. 20-pin SOIC (0.513 × 0.300 × 0.0932 Inches) Package Outline, 51-85024

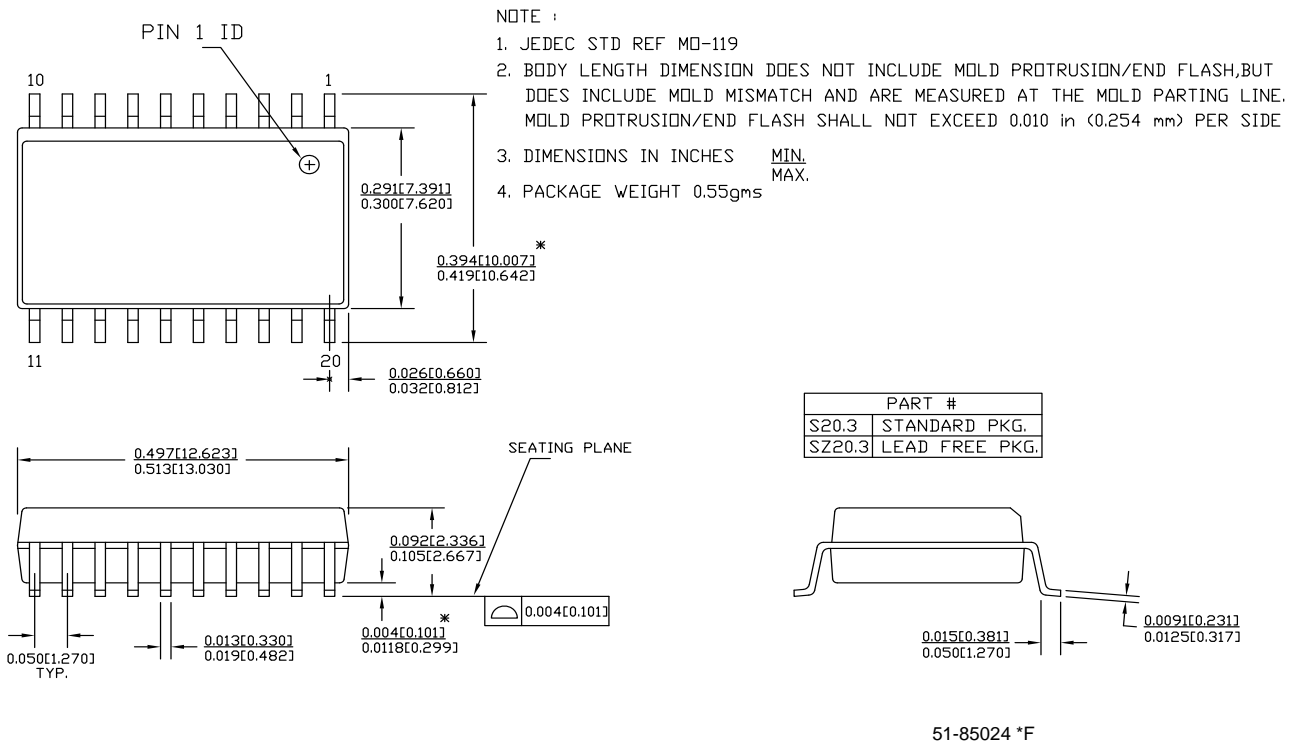

**Note**

22. These parameters are guaranteed by design and are not tested.

## Acronyms

Table 1. Acronyms Used in this Document

Acronym	Description
CLKIN	Clock Input
CMOS	complementary Metal Oxide Semiconductor
OE	Output Enable
PLL	Phase Locked Loop
SPLL	System Phase Locked Loop
PPM	Parts Per Million
FTG	Frequency Time Generator
FAE	Field Application Engineer

## Document Conventions

### Units of Measure

Table 2. Units of Measure

Symbol	Unit of Measure
°C	degrees Celsius
fF	femtofarad
KB	1024 bytes
Kbit	1024 bits
kHz	kilohertz
MHz	megahertz
MΩ	megaohm
μA	microampere
μF	microfarad
μH	microhenry
μs	microsecond
μV	microvolt
mA	milliampere
ms	millisecond
nA	nanoampere
ns	nanosecond
nV	nanovolt
pA	picoampere
pF	picofarad
pp	peak-to-peak
ppm	parts per million
ps	picosecond

Document History Page

Document Title: CY2291, Three-PLL General Purpose EPROM Programmable Clock Generator				
Document Number: 38-07189				
Revision	ECN	Orig. of Change	Submission Date	Description of Change
**	110321	SZV	10/28/01	Change from Spec number: 38-00410 to 38-07189
*A	121836	RBI	12/14/02	Updated <a href="#">Operating Conditions</a> : Added t <sub>PJ</sub> parameter and its details.
*B	276756	RGL	10/18/04	Updated <a href="#">Ordering Information</a> : Updated part numbers.
*C	2565316	AESA / KVM	09/16/08	Updated <a href="#">Functional Overview</a> : Updated <a href="#">CyClocks Software</a> : Updated description. Updated <a href="#">Ordering Information</a> : Updated part numbers. Replaced "Lead-Free" with "Pb-Free". Added Note "Not recommended for new designs." and referred the same note in "CY2291F1". Updated <a href="#">Packaging Information</a> : Updated <a href="#">Package Diagram</a> : spec 51-85024 – Changed revision from *B to *C. Updated to new template.
*D	2898985	KVM	03/25/2010	Updated <a href="#">Ordering Information</a> : Updated part numbers. Removed Note "Not recommended for new designs." and its reference. Added <a href="#">Possible Configurations</a> (for "xxx" parts). Added Note "Some product offerings are factory programmed customer specific devices with customized part numbers. The Possible Configurations table shows the available device types, but not complete part numbers. Contact your local Cypress FAE or Sales Representative for more information." and referred the same note in "Ordering Code" column in Possible Configurations. Updated <a href="#">Package Diagram</a> : spec 51-85024 – Changed revision from *C to *D.
*E	3080949	BASH	11/10/2010	Removed Benefits. Added <a href="#">Functional Description</a> . Updated <a href="#">Functional Overview</a> : Removed Operation. Added <a href="#">Acronyms</a> and <a href="#">Units of Measure</a> . Updated to new template.
*F	3450141	PURU	01/12/2011	Updated <a href="#">Pin Definitions</a> : Added Note 1 and referred the same note in 32XOUT pin. Removed Note "Please refer to application note "Understanding the CY2291, CY2292 and CY2295" for more information." and its reference. Updated <a href="#">Switching Characteristics</a> : Removed Note "Please refer to application note "Understanding the CY2291, CY2292 and CY2295" for more information." and its reference. Updated <a href="#">Switching Characteristics</a> : Removed Note "Please refer to application note "Understanding the CY2291, CY2292 and CY2295" for more information." and its reference. Updated <a href="#">Switching Characteristics</a> : Removed Note "Please refer to application note "Understanding the CY2291, CY2292 and CY2295" for more information." and its reference. Updated <a href="#">Switching Characteristics</a> : Removed Note "Please refer to application note "Understanding the CY2291, CY2292 and CY2295" for more information." and its reference. Updated <a href="#">Packaging Information</a> : Updated <a href="#">Package Characteristics</a> : Changed value of $\theta_{JA}$ parameter from 125 °C/W to 70 °C/W. Changed value of $\theta_{JC}$ parameter from 25 °C/W to 46 °C/W.
*G	3849272	PURU	12/21/2012	Removed "Understanding the CY2291 and CY2292" application note related information in all instances across the document.

**Document History Page** *(continued)*

Document Title: CY2291, Three-PLL General Purpose EPROM Programmable Clock Generator Document Number: 38-07189				
Revision	ECN	Orig. of Change	Submission Date	Description of Change
*H	4201345	CINM	11/25/2013	Updated <a href="#">Packaging Information</a> : Updated <a href="#">Package Diagram</a> : spec 51-85024 – Changed revision from *D to *E. Updated to new template. Completing Sunset Review.
*I	4576237	XHT	11/21/2014	Updated <a href="#">Functional Description</a> : Added "For a complete list of related documentation, click <a href="#">here</a> ." at the end. Updated <a href="#">Packaging Information</a> : Updated <a href="#">Package Diagram</a> : spec 51-85024 – Changed revision from *E to *F.
*J	5528179	XHT	11/21/2016	Updated to new template. Completing Sunset Review.
*K	5754889	PSR	05/31/2017	Updated Cypress logo, Copyright information, and Sales page. Updated <a href="#">Packaging Information</a> . Delete all Industrial range references in the datasheet. Updated <a href="#">Selection Guide</a> , <a href="#">Packaging Information</a> , <a href="#">Operating Conditions</a> .

## Sales, Solutions, and Legal Information

### Worldwide Sales and Design Support

Cypress maintains a worldwide network of offices, solution centers, manufacturer's representatives, and distributors. To find the office closest to you, visit us at [Cypress Locations](#).

#### Products

ARM <sup>®</sup> Cortex <sup>®</sup> Microcontrollers	<a href="http://cypress.com/arm">cypress.com/arm</a>
Automotive	<a href="http://cypress.com/automotive">cypress.com/automotive</a>
Clocks & Buffers	<a href="http://cypress.com/clocks">cypress.com/clocks</a>
Interface	<a href="http://cypress.com/interface">cypress.com/interface</a>
Internet of Things	<a href="http://cypress.com/iot">cypress.com/iot</a>
Memory	<a href="http://cypress.com/memory">cypress.com/memory</a>
Microcontrollers	<a href="http://cypress.com/mcu">cypress.com/mcu</a>
PSoC	<a href="http://cypress.com/psoc">cypress.com/psoc</a>
Power Management ICs	<a href="http://cypress.com/pmic">cypress.com/pmic</a>
Touch Sensing	<a href="http://cypress.com/touch">cypress.com/touch</a>
USB Controllers	<a href="http://cypress.com/usb">cypress.com/usb</a>
Wireless Connectivity	<a href="http://cypress.com/wireless">cypress.com/wireless</a>

#### PSoC<sup>®</sup> Solutions

[PSoC 1](#) | [PSoC 3](#) | [PSoC 4](#) | [PSoC 5LP](#) | [PSoC 6](#)

#### Cypress Developer Community

[Forums](#) | [WICED IOT Forums](#) | [Projects](#) | [Video](#) | [Blogs](#) | [Training](#) | [Components](#)

#### Technical Support

[cypress.com/support](http://cypress.com/support)

---



© Cypress Semiconductor Corporation, 2001-2017. This document is the property of Cypress Semiconductor Corporation and its subsidiaries, including Spansion LLC ("Cypress"). This document, including any software or firmware included or referenced in this document ("Software"), is owned by Cypress under the intellectual property laws and treaties of the United States and other countries worldwide. Cypress reserves all rights under such laws and treaties and does not, except as specifically stated in this paragraph, grant any license under its patents, copyrights, trademarks, or other intellectual property rights. If the Software is not accompanied by a license agreement and you do not otherwise have a written agreement with Cypress governing the use of the Software, then Cypress hereby grants you a personal, non-exclusive, nontransferable license (without the right to sublicense) (1) under its copyright rights in the Software (a) for Software provided in source code form, to modify and reproduce the Software solely for use with Cypress hardware products, only internally within your organization, and (b) to distribute the Software in binary code form externally to end users (either directly or indirectly through resellers and distributors), solely for use on Cypress hardware product units, and (2) under those claims of Cypress's patents that are infringed by the Software (as provided by Cypress, unmodified) to make, use, distribute, and import the Software solely for use with Cypress hardware products. Any other use, reproduction, modification, translation, or compilation of the Software is prohibited.

TO THE EXTENT PERMITTED BY APPLICABLE LAW, CYPRESS MAKES NO WARRANTY OF ANY KIND, EXPRESS OR IMPLIED, WITH REGARD TO THIS DOCUMENT OR ANY SOFTWARE OR ACCOMPANYING HARDWARE, INCLUDING, BUT NOT LIMITED TO, THE IMPLIED WARRANTIES OF MERCHANTABILITY AND FITNESS FOR A PARTICULAR PURPOSE. To the extent permitted by applicable law, Cypress reserves the right to make changes to this document without further notice. Cypress does not assume any liability arising out of the application or use of any product or circuit described in this document. Any information provided in this document, including any sample design information or programming code, is provided only for reference purposes. It is the responsibility of the user of this document to properly design, program, and test the functionality and safety of any application made of this information and any resulting product. Cypress products are not designed, intended, or authorized for use as critical components in systems designed or intended for the operation of weapons, weapons systems, nuclear installations, life-support devices or systems, other medical devices or systems (including resuscitation equipment and surgical implants), pollution control or hazardous substances management, or other uses where the failure of the device or system could cause personal injury, death, or property damage ("Unintended Uses"). A critical component is any component of a device or system whose failure to perform can be reasonably expected to cause the failure of the device or system, or to affect its safety or effectiveness. Cypress is not liable, in whole or in part, and you shall and hereby do release Cypress from any claim, damage, or other liability arising from or related to all Unintended Uses of Cypress products. You shall indemnify and hold Cypress harmless from and against all claims, costs, damages, and other liabilities, including claims for personal injury or death, arising from or related to any Unintended Uses of Cypress products.

Cypress, the Cypress logo, Spansion, the Spansion logo, and combinations thereof, WICED, PSoC, CapSense, EZ-USB, F-RAM, and Traveo are trademarks or registered trademarks of Cypress in the United States and other countries. For a more complete list of Cypress trademarks, visit [cypress.com](http://cypress.com). Other names and brands may be claimed as property of their respective owners.

## Looking for pricing, stock, or lifecycle information?

Click below to explore more details on WIN SOURCE:

-  [View CY2291FX on WIN SOURCE](#)
-  [Cypress Semiconductor Corp](#) Information

## Optimize Your Supply Chain with WIN SOURCE Solutions

-  Global Sourcing Solution
-  Obsolete Management
-  Cost Control Management
-  Shortage Management
-  Alternative Solution
-  Excess Inventory Management