

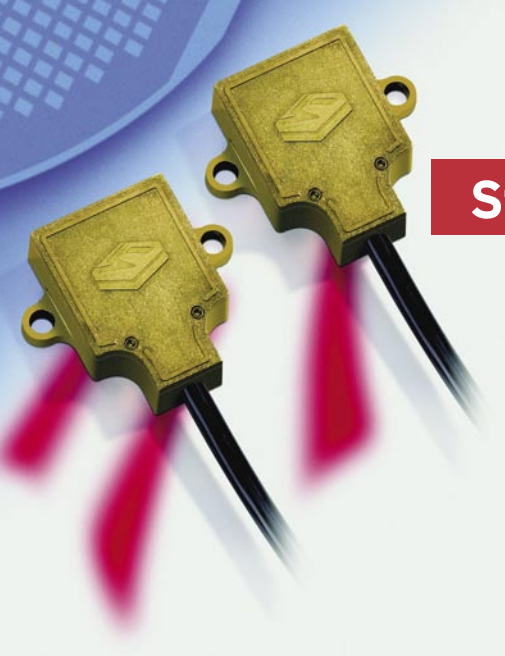

**THE DATASHEET OF
SCA125T-D08-A**





SCA115T and SCA125T Series

Stand Alone Inclinometer

Single or dual axis RS-485 output

FEATURES

- Silicon 3D MEMS sensor
- RS-485 serial interface
- 11 bit resolution
- Operating temperature range -40...+85°C
- Inclination and temperature output
- Long term stability < 0,02°
- Shock resistance >20 000g
- 30x30x13mm size, single or dual axis
- Horizontal or vertical mounting

BENEFITS

- Excellent long term stability
- Sensing element controlled frequency response
- Outstanding shock durability
- Harsh environment robustness

APPLICATIONS

- Platform tilt measurement
- Equipment and instrument condition monitoring
- Inclination based position measurement
- Rotational orientation measurement (dual axis)

For customised product please contact VTI Technologies

ELECTRICAL CHARACTERISTICS

Parameter	Condition	Min.	Typ	Max.	Units
Supply voltage		7	16	35	V
Current consumption			20		mA
Output	RS-485, half-duplex				kΩ
Data transfer speed	11 bit word		10		Hz

PERFORMANCE CHARACTERISTICS

Parameter	Condition	SCA115T-D03	SCA125T-D06	SCA125T-D08	Units
Measuring range ⁽¹⁾		±30	±90	±30	°
Measuring axis	(see "Directions")	X	X-Y	X-Y	
Offset ^(2,5)	Output at 0°, HEX 03FF	FS/2	FS/2	FS/2	
Offset temperature error	0...70°C	±0,2	±0,2	±0,2	°
	-25...85°C	±0,6	±0,6	±0,6	°
Resolution ⁽⁵⁾	@ 0° (offset position)	0,035	0,07	0,035	°/LSB
		11	11	11	Bit/FS
Sensitivity	Sine of inclination	30	90	30	°/FS
Sensitivity temperature error ⁽⁵⁾	0...70°C	±0,2	±0,2	±0,2	%
	-25...85°C	±0,5	±0,5	±0,5	%
Nonlinearity	Sinus output	0,1	N/A	0,1	°
Frequency response -3dB ⁽³⁾		18	18	18	Hz
Cross-axis sensitivity ⁽⁴⁾		4	4	4	%

Typical values @ ambient temperature unless otherwise specified.

Note 1. The measuring range is limited by the sensitivity and offset.

Note 2. Offset specified as Output @ 0°.

Note 3. The frequency response is determined by the sensing element's internal gas damping. The output has true DC (0Hz) response.

Note 4. The cross-axis sensitivity determines how much inclination, perpendicular to the measuring axis, couples to the output.

Note 5. Mounting position should be calibrated. See measuring positions.

MEASURING DIRECTIONS

X-axis

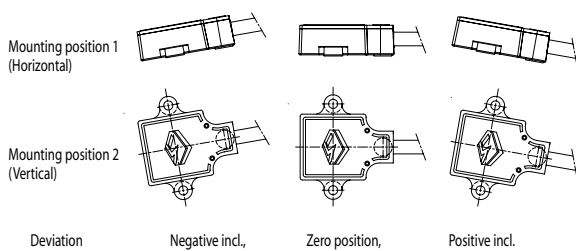

Y-axis

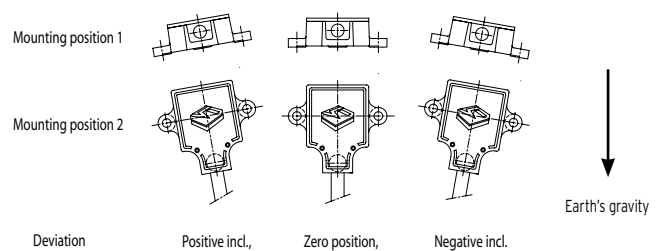

Figure 1. Positions

Notes:

- It is important that the part is parallel to the mounting plane, and that the output equals the zero value when sensor is in zero position.
- Zero position: Please note the picture above which provides information on how the output of the accelerometer behaves in different circumstances when assembled. Please also note that you can rotate the part around the measuring plane for optimum mounting location

SCA115T and SCA125T Series

ELECTRICAL CONNECTION

Wire color	Name	Function
Yellow	A	Bus connection
White	B	Bus connection
Green		NC
Blue	GND	Ground
Red	V _{cc}	Power supply

SOFTWARE LEVELS

Modules are available with different software levels:

Level	Output
A	<ul style="list-style-type: none"> • Acc/Incl and temperature in counts (HEX data) • Communication configurability (RS-485 bus) • Device address changeability
B	<ul style="list-style-type: none"> • "A" + output in mg, temperature in °F or °C • Adjustable averaging of acc/incl signal(s) • Adjustable offset for acc/incl signal(s)
C	<ul style="list-style-type: none"> • "A" + "B" + output in mrad or degree • Adjustable offset for acc/incl signal(s)

See separate manual for more detailed information

MECHANICAL SPECIFICATION

Cable length: 30 cm
 Total weight: approx. 60 grams (excluding connector)
 Protection class: IP66 (excluding connector)
 Metal part: Housing: Yellow chromated zinc casting
 Bracket: Yellow passivated steel

MOUNTING

The sensor module is to be mounted on a flat and smooth surface with 2 screws, dimension M4. Mounting torque 5 ± 1 Nm.

SENSOR DIMENSIONS

Dimensions (in mm):

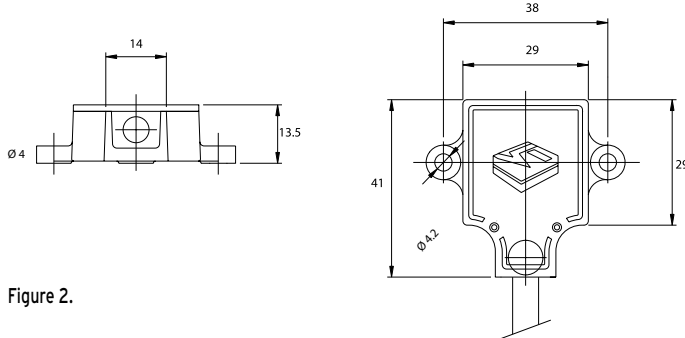

Figure 2.

ORDERING INFORMATION

SCA1X5T-DOY, Z

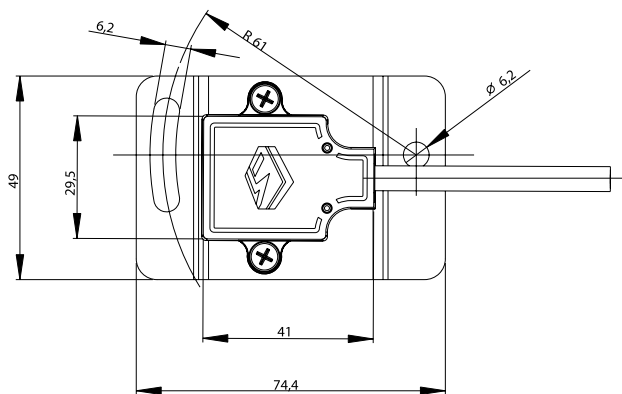
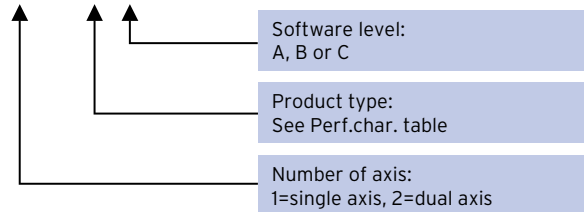
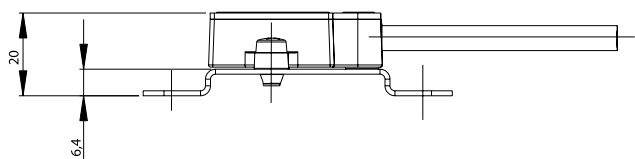



Figure 3.
Optional mounting bracket



Looking for pricing, stock, or lifecycle information?

Click below to explore more details on WIN SOURCE:

-  [View SCA125T-D08-A on WIN SOURCE](#)
-  [Murata Electronics North America Information](#)

Optimize Your Supply Chain with WIN SOURCE Solutions

-  Global Sourcing Solution
-  Obsolete Management
-  Cost Control Management
-  Shortage Management
-  Alternative Solution
-  Excess Inventory Management