



**THE DATASHEET OF
MLX92215LUA-AAA-000-BU**



Features and Benefits

- Wide operating voltage range: 2.7V - 24V
- Chopper-stabilized amplifier stage
- Built-in negative temperature coefficient
- Reverse Supply Voltage Protection
- High ESD rating / Excellent EMC performance

Applications

- Consumer and Industrial
- Solid-state switch
- E-Bike
- Motorcycles
- 3-phase BLDC motor commutation

Ordering information

Part No.	Temperature Code	Package Code	Comment
MLX92215LUA-AAA-000-BU	L (-40°C to 150°C)	UA (TO92-3L)	B _{OP} /B _{RP} = ± 3mT, TC = -1100 ppm/°C
MLX92215LSE-AAA-000-RE	L (-40°C to 150°C)	SE (TSOT-23)	B _{OP} /B _{RP} = ± 3mT, TC = -1100 ppm/°C
MLX92215LSE-ACA-000-RE	L (-40°C to 150°C)	SE (TSOT-23)	B _{OP} /B _{RP} = ± 3mT, TC = -2000 ppm/°C Inverted output
MLX92215LUA-AEA-000-BU	L (-40°C to 150°C)	UA (TO92-3L)	B _{OP} /B _{RP} = ± 3mT, TC = -1100 ppm/°C
MLX92215LSE-AEA-000-RE	L (-40°C to 150°C)	SE (TSOT-23)	B _{OP} /B _{RP} = ± 3mT, TC = -1100 ppm/°C
MLX92215LSE-AFA-000-RE	L (-40°C to 150°C)	SE (TSOT-23)	North Active MLX92215LSE-AEA-000
MLX92215KLD-AAA-000-RE	K (-40°C to 125°C)	LD (UTQFN)	B _{OP} /B _{RP} = ± 3mT, TC = -1100 ppm/°C
MLX92215LST-AAA-000-RE	L (-40°C to 150°C)	ST (SOT-23)	B _{OP} /B _{RP} = ± 3mT, TC = -1100 ppm/°C

Option code	HBM
Lxx-AAA, LSE-ACA	4kV
Lxx-AEA, LSE-AFA, KLD-AAA, LST-AAA	8kV

1. Functional Diagram

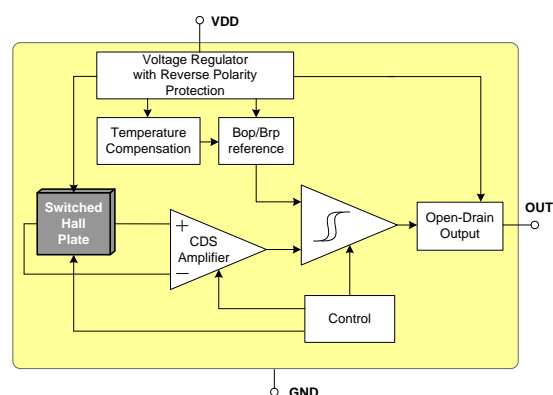

2. General Description

The Melexis MLX92215 is the second generation Hall-effect latch designed in mixed signal CMOS technology. The device integrates a voltage regulator, Hall sensor with advanced offset cancellation system and an open-drain output driver, all in a single package. Based on the existing platform, the magnetic core is using an improved offset cancellation system allowing faster and more accurate processing while being temperature insensitive and stress independent. In addition is implemented a negative temperature coefficient to compensate the natural behaviour of magnets becoming weaker with rise in temperature.

The included voltage regulator operates from 2.7V to 24V, hence covering a wide range of applications. With the built-in reverse voltage protection, a serial resistor or diode on the supply line is not required so that even remote sensors can be specified for low voltage operation down to 2.7V while being reverse voltage tolerant.

With latching magnetic characteristics, the output is turned low or high respectively with a sufficiently strong South or North pole facing the package top side. When removing the magnetic field, the device keeps its previous state.

Contents

Features and Benefits.....	1
Applications.....	1
Ordering information	1
1. Functional Diagram	1
2. General Description.....	1
3. Absolute Maximum Ratings.....	4
4. General Electrical Specifications.....	5
5. Magnetic Specifications.....	6
5.1. MLX92215LSE-AAA-000 / MLX92215LUA-AAA-000.....	6
5.2. MLX92215LSE-ACA-000.....	6
5.3. MLX92215LUA-AEA-000 / MLX92215LSE-AEA-000	6
5.4. MLX92215LSE-AFA-000	6
5.5. MLX92215KLD-AAA-000	7
5.6. MLX92215LST-AAA-000.....	7
6. Output Behavior versus Magnetic Pole	8
6.1. South Pole Active	8
6.2. North Pole Active	8
7. Performance Graphs	9
7.1. Magnetic parameters vs. T_A	9
7.2. Magnetic parameters vs. V_{DD}	9
7.3. V_{DSON} vs. T_A	9
7.4. V_{DSON} vs. V_{DD}	9
7.5. I_{DD} vs. T_A	9
7.6. I_{DD} vs. V_{DD}	9
7.7. I_{OFF} vs. T_A	10
7.8. I_{OFF} vs. V_{OUT}	10
7.9. SE Power Derating vs. T_A	10
7.10. UA Voltage Derating vs. T_A	10
7.11. LD power Derating vs. T_A	10
8. Application Information.....	11
8.1. Typical Three-Wire Application Circuit	11

9. Standard information	12
10. ESD Precautions	12
11. Packages.....	13
11.1. TSOT-3L (SE Package)	13
11.2. TO92-3L (UA Package) - For Future Use	15
11.3. TO92-3L (UA Package) - Not for Future Use.....	17
11.4. UTQFN (LD Package).....	19
11.5. SOT-3L (ST Package)	21
12. Disclaimer.....	23

3. Absolute Maximum Ratings

Parameter	Symbol	Value	Units
Supply Voltage ^(1, 2)	V _{DD}	+27	V
Supply Voltage (Load dump) ^(1, 3)	V _{DD}	+32	V
Supply Current ^(1, 2, 4)	I _{DD}	+20	mA
Supply Current ^(1, 3, 4)	I _{DD}	+50	mA
Reverse Supply Voltage ^(1, 2)	V _{DDREV}	-24	V
Reverse Supply Voltage (Load dump) ^(1, 3)	V _{DDREV}	-30	V
Reverse Supply Current ^(1, 2, 5)	I _{DDREV}	-20	mA
Reverse Supply Current ^(1, 3, 5)	I _{DDREV}	-50	mA
Output Voltage ^(1, 2)	V _{OUT}	+27	V
Output Current ^(1, 2, 5)	I _{OUT}	+20	mA
Output Current ^(1, 3, 6)	I _{OUT}	+75	mA
Reverse Output Voltage ⁽¹⁾	V _{OUTREV}	-0.5	V
Reverse Output Current ^(1, 2)	I _{OUTREV}	-50	mA
Operating Temperature Range	T _A	-40 to +150	°C
Storage Temperature Range	T _S	-55 to +165	°C
Maximum Junction Temperature ⁽⁷⁾	T _J	+165	°C
ESD Sensitivity – HBM ^(8, 9)	-	4000	V
ESD Sensitivity – HBM ^(8, 10)	-	8000	V
ESD Sensitivity – MM ⁽¹¹⁾	-	500	V
ESD Sensitivity – CDM ⁽¹²⁾	-	1000	V
Magnetic Flux Density	B	Unlimited	mT

Exceeding the absolute maximum ratings may cause permanent damage. Exposure to absolute-maximum-rated conditions for extended periods may affect device reliability.

¹ The maximum junction temperature should not be exceeded

² For maximum 1 hour

³ For maximum 0.5 s

⁴ Including current through protection device

⁵ Through protection device

⁶ For V_{OUT} ≤ 27V

⁷ For 1000 hours

⁸ Human Model according AEC-Q100-002 standard

⁹ Valid for version Lxx-AAA and LSE-ACA

¹⁰ Valid for version Lxx-AEA, LSE-AFA, KLD-AAA, LST-AAA

¹¹ Machine Model according AEC-Q100-003 standard

¹² Charged Device Model according AEC-Q100-011 standard

4. General Electrical Specifications

DC Operating Parameters $T_A = -40^{\circ}\text{C}$ to 150°C , $V_{DD} = 2.7\text{V}$ to 24V (unless otherwise specified)

Parameter	Symbol	Test Conditions	Min	Typ ⁽¹⁾	Max	Units
Supply Voltage	V_{DD}	Operating	2.7	-	24	V
Supply Current	I_{DD}		1.5	3.0	4.5	mA
Reverse Supply Current	I_{DDREV}	$V_{DD} = -18\text{V}$			1	mA
Output Leakage Current	I_{OFF}	$V_{OUT} = 12\text{V}$, $V_{DD} = 12\text{V}$, $B < B_{rp}$		0.1	10	μA
Output Saturation Voltage	V_{DSON}	$B > B_{OP}$, $V_{DD} = 3\text{V}$ to 24V , $I_{OUT} = 20\text{mA}$		0.2	0.5	V
Output Rise Time ⁽²⁾ (R_{PU} dependent)	t_R	$V_{DD} = 12\text{V}$, $V_{PU}^{(3)} = 5\text{V}$, $R_{PU} = 1\text{k}\Omega$ $C_{LOAD} = 50\text{pF}$ to GND	0.1	0.3	1	μs
Output Fall Time ⁽²⁾ (On-chip controlled)	t_F	$V_{DD} = 12\text{V}$, $V_{PU} = 5\text{V}$, $R_{PU} = 1\text{k}\Omega$ $C_{LOAD} = 50\text{pF}$ to GND	0.1	0.3	1	μs
Chopping Frequency	f_{CHOP}			340		kHz
Output Refresh Period ⁽²⁾	t_{PER}			6		μs
Delay time ^(2,4)	t_D	Average over 1000 successive switching events @10kHz, square wave with $B \geq 30\text{mT}$, $t_{RISE} = t_{FALL} \leq 20\mu\text{s}$		6		μs
Output Jitter (p-p) ^(2,5)	t_{JITTER}	Over 1000 successive switching events @1kHz, square wave with $B \geq 30\text{mT}$, $t_{RISE} = t_{FALL} \leq 100\mu\text{s}$		± 3		μs
Maximum Switching Frequency ^(2,6)	f_{SW}	$B \geq 30\text{mT}$ and square wave magnetic field	30	50		kHz
Power-On Time ^(7,8)	t_{ON}	$V_{DD} = 5\text{V}$, $dV_{DD}/dt > 2\text{V}/\mu\text{s}$		16	35	μs
SE Package Thermal Resistance	R_{TH}	Single layer (1S) Jedec board		300		$^{\circ}\text{C}/\text{W}$
UA Package Thermal Resistance	R_{TH}	Single layer (1S) Jedec board		200		$^{\circ}\text{C}/\text{W}$
LD Package Thermal Resistance	R_{TH}	Single layer (1S) Jedec board		250		$^{\circ}\text{C}/\text{W}$

¹ Typical values are defined at $T_A = +25^{\circ}\text{C}$ and $V_{DD} = 12\text{V}$

² Guaranteed by design and verified by characterization, not production tested

³ R_{PU} and V_{PU} are respectively the external pull-up resistor and pull-up power supply

⁴ The Delay Time is the time from magnetic threshold reached to the start of the output switching

⁵ Output jitter is the unpredictable deviation of the Delay time

⁶ Maximum switching frequency corresponds to the maximum frequency of the applied magnetic field which is detected without loss of pulses

⁷ The Power-On Time represents the time from reaching $V_{DD} = V_{POR}$ to the first refresh of the output (first valid output state)

⁸ Power-On Slew Rate (is not critical for the proper device start-up)

5. Magnetic Specifications

5.1. MLX92215LSE-AAA-000 / MLX92215LUA-AAA-000

DC Operating Parameters $V_{DD} = 3V$ to $24V$, $T_A = -40^{\circ}C$ to $150^{\circ}C$

Test Condition	Operating Point B_{OP} (mT)			Release Point B_{RP} (mT)			TC (ppm/ $^{\circ}C$)	Active Pole
	Min	Typ ⁽¹⁾	Max	Min	Typ ⁽¹⁾	Max		
$T_A = -40^{\circ}C$	1.0	3.2	5.0	-5.0	-3.2	-1.0	-1100 ⁽²⁾	South Pole
$T_A = 25^{\circ}C$	1.0	3.0	5.0	-5.0	-3.0	-1.0		
$T_A = 150^{\circ}C$	0.5	2.6	5.0	-5.0	-2.6	-0.5		

5.2. MLX92215LSE-ACA-000

DC Operating Parameters $V_{DD} = 3V$ to $24V$, $T_A = -40^{\circ}C$ to $150^{\circ}C$

Test Condition	Operating Point B_{OP} (mT)			Release Point B_{RP} (mT)			TC (ppm/ $^{\circ}C$)	Active Pole
	Min	Typ ⁽¹⁾	Max	Min	Typ ⁽¹⁾	Max		
$T_A = -40^{\circ}C$	1.2	3.2	5.5	-5.5	-3.2	-1.2	-2000 ⁽²⁾	North Pole
$T_A = 25^{\circ}C$	1.0	2.8	4.7	-4.7	-2.8	-1.0		
$T_A = 150^{\circ}C$	0.5	2.1	4.2	-4.2	-2.1	-0.5		

5.3. MLX92215LUA-AEA-000 / MLX92215LSE-AEA-000

DC Operating Parameters $V_{DD} = 3V$ to $24V$, $T_A = -40^{\circ}C$ to $150^{\circ}C$

Test Condition	Operating Point B_{OP} (mT)			Release Point B_{RP} (mT)			TC (ppm/ $^{\circ}C$)	Active Pole
	Min	Typ ⁽¹⁾	Max	Min	Typ ⁽¹⁾	Max		
$T_A = -40^{\circ}C$	1.0	3.2	5.0	-5.0	-3.2	-1.0	-1100 ⁽²⁾	South Pole
$T_A = 25^{\circ}C$	1.0	3.0	5.0	-5.0	-3.0	-1.0		
$T_A = 150^{\circ}C$	0.5	2.6	5.0	-5.0	-2.6	-0.5		

5.4. MLX92215LSE-AFA-000

DC Operating Parameters $V_{DD} = 3V$ to $24V$, $T_A = -40^{\circ}C$ to $150^{\circ}C$

Test Condition	Operating Point B_{OP} (mT)			Release Point B_{RP} (mT)			TC (ppm/ $^{\circ}C$)	Active Pole
	Min	Typ ⁽¹⁾	Max	Min	Typ ⁽¹⁾	Max		
$T_A = -40^{\circ}C$	1.0	3.2	5.0	-5.0	-3.2	-1.0	-1100 ⁽²⁾	North Pole
$T_A = 25^{\circ}C$	1.0	3.0	5.0	-5.0	-3.0	-1.0		
$T_A = 150^{\circ}C$	0.5	2.6	5.0	-5.0	-2.6	-0.5		

¹ Typical values are defined at $T_A = +25^{\circ}C$ and $V_{DD} = 12V$

² $TC = \frac{B_{T_2} - B_{T_1}}{B_{25^{\circ}C} \times (T_2 - T_1)} \times 10^6, \left[\frac{ppm}{^{\circ}C} \right]; T_1 = -40^{\circ}C; T_2 = 150^{\circ}C$, value guaranteed by design and verified by characterization, not production tested

3-Wire Hall Effect Latch

5.5. MLX92215KLD-AAA-000

DC Operating Parameters $V_{DD} = 3V$ to $24V$, $T_A = -40^{\circ}C$ to $125^{\circ}C$

Test Condition	Operating Point B_{OP} (mT)			Release Point B_{RP} (mT)			TC (ppm/ $^{\circ}C$)	Active Pole
	Min	Typ ⁽¹⁾	Max	Min	Typ ⁽¹⁾	Max		
$T_A = -40^{\circ}C$	1.0	3.2	5.0	-5	-3.2	-1.0	-1100 ⁽²⁾	South Pole
$T_A = 25^{\circ}C$	1.0	3.0	5.0	-5	-3.0	-1.0		
$T_A = 125^{\circ}C$	0.5	2.6	5.0	-5	-2.6	-0.5		

5.6. MLX92215LST-AAA-000

DC Operating Parameters $V_{DD} = 3V$ to $24V$, $T_A = -40^{\circ}C$ to $150^{\circ}C$

Test Condition	Operating Point B_{OP} (mT)			Release Point B_{RP} (mT)			TC (ppm/ $^{\circ}C$)	Active Pole
	Min	Typ ⁽¹⁾	Max	Min	Typ ⁽¹⁾	Max		
$T_A = -40^{\circ}C$	1.0	3.2	5.0	-5.0	-3.2	-1.0	-1100 ⁽²⁾	South Pole
$T_A = 25^{\circ}C$	1.0	3.0	5.0	-5.0	-3.0	-1.0		
$T_A = 150^{\circ}C$	0.5	2.6	5.0	-5.0	-2.6	-0.5		

¹ Typical values are defined at $T_A = +25^{\circ}C$ and $V_{DD} = 12V$

² $TC = \frac{B_{T_2} - B_{T_1}}{B_{25^{\circ}C} \times (T_2 - T_1)} \times 10^6, \left[\frac{ppm}{^{\circ}C} \right]; T_1 = -40^{\circ}C; T_2 = 150^{\circ}C$, value guaranteed by design and verified by characterization, not production tested

6. Output Behavior versus Magnetic Pole

Output behaviour versus magnetic pole ⁽¹⁾

6.1. South Pole Active

DC Operating Parameters $T_A = -40^{\circ}\text{C}$ to 150°C , $V_{DD} = 2.7\text{V}$ to 24V

Parameter	Test Conditions	OUT
South pole	$B > B_{OP}$	Low (V_{DSon})
North pole	$B < B_{RP}$	High (V_{PU}) ⁽²⁾

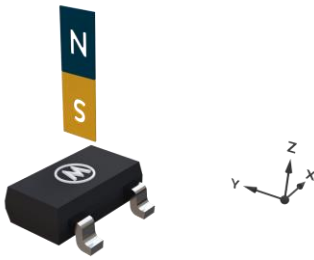

6.2. North Pole Active

DC Operating Parameters $T_A = -40^{\circ}\text{C}$ to 150°C , $V_{DD} = 2.7\text{V}$ to 24V

Parameter	Test Conditions	OUT
South pole	$B > B_{OP}$	High (V_{PU}) ⁽²⁾
North pole	$B < B_{RP}$	Low (V_{DSon})

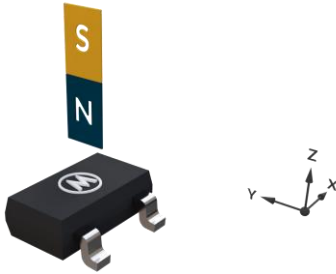

¹ Magnetic pole facing the branded/top side of the package

² Default Output state during power-up

7. Performance Graphs

7.1. Magnetic parameters vs. T_A

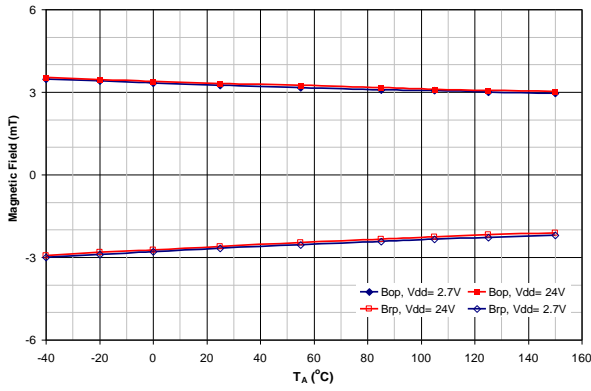

7.2. Magnetic parameters vs. V_{DD}

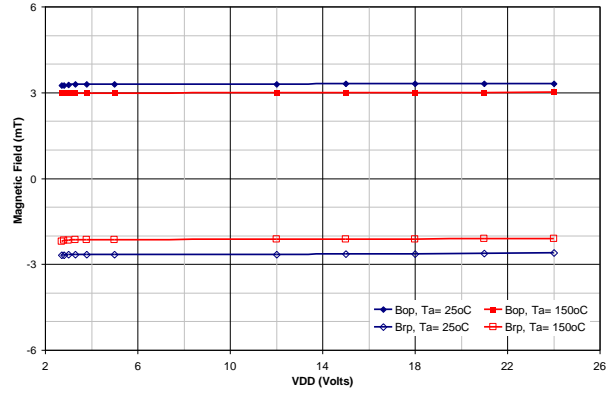

7.3. V_{DSON} vs. T_A

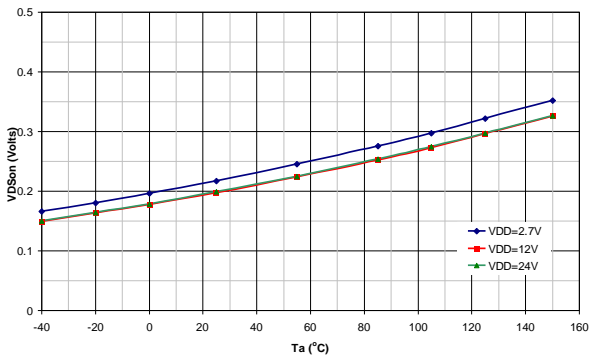

7.4. V_{DSON} vs. V_{DD}

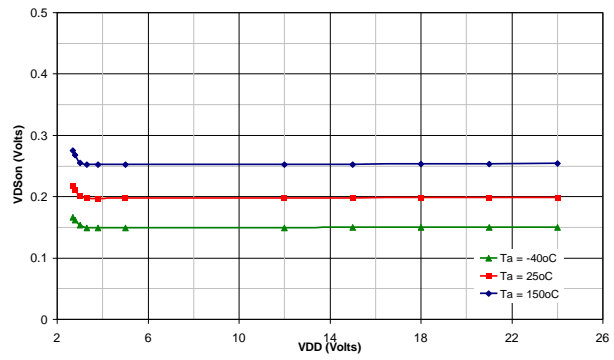

7.5. I_{DD} vs. T_A

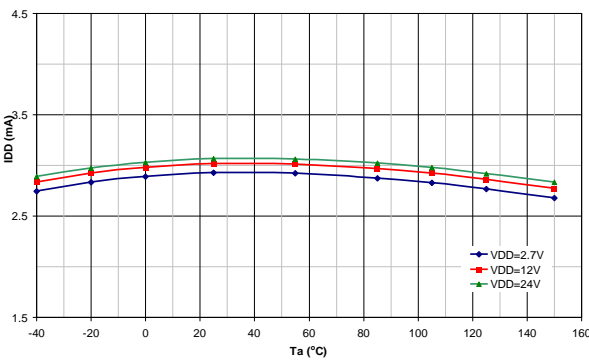

7.6. I_{DD} vs. V_{DD}

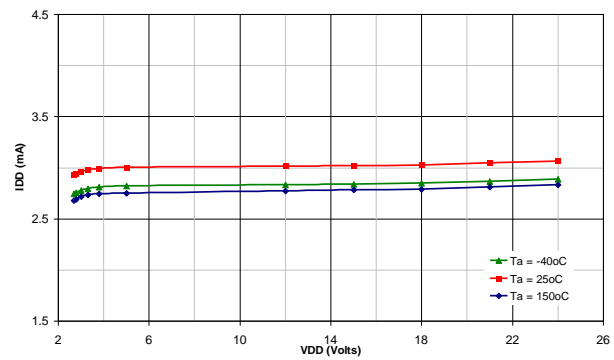

3-Wire Hall Effect Latch

7.7. I_{OFF} vs. T_A

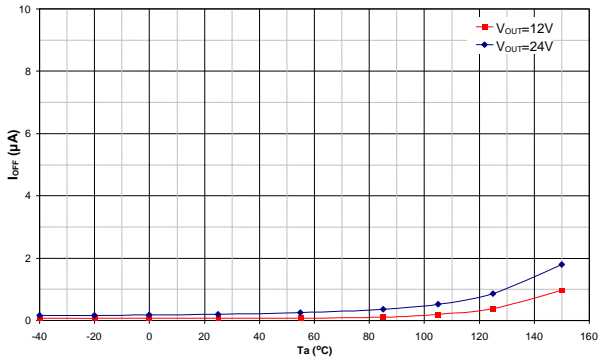

7.8. I_{OFF} vs. V_{OUT}

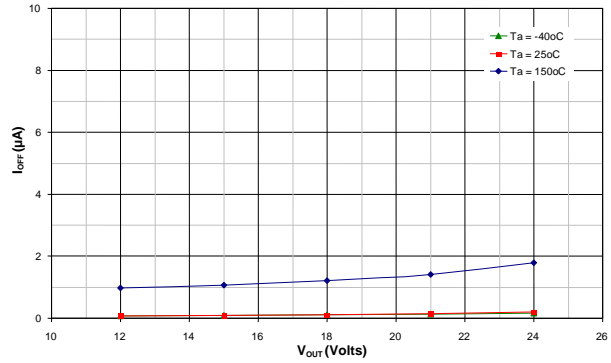

7.9. SE Power Derating vs. T_A

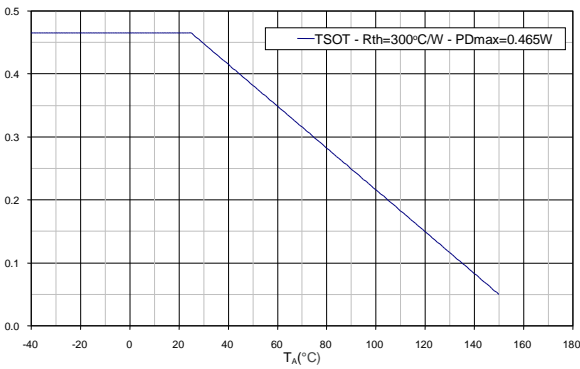

7.10. UA Voltage Derating vs. T_A

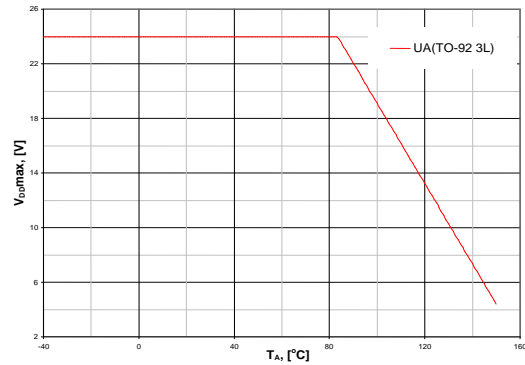

7.11. LD power Derating vs. T_A

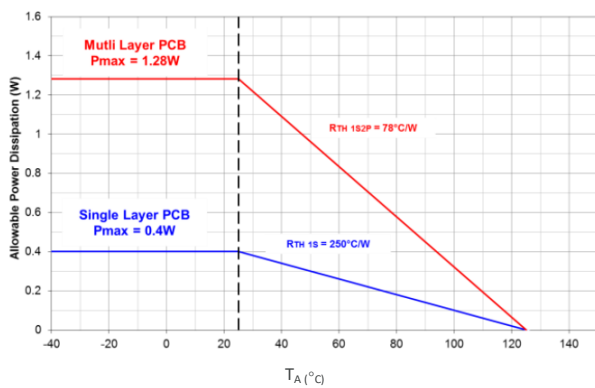

8. Application Information

8.1. Typical Three-Wire Application Circuit

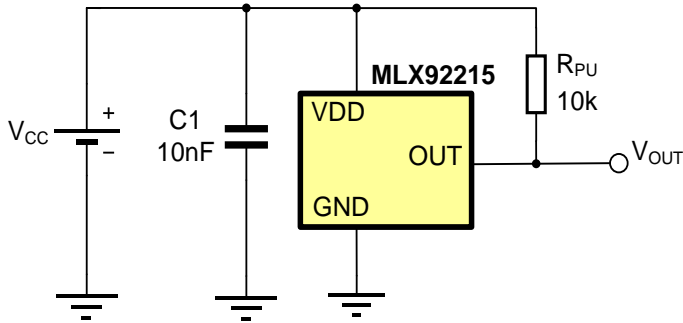

Notes:

1. For proper operation, a 10nF to 100nF bypass capacitor should be placed as close as possible to the V_{DD} and ground pin.
2. The pull-up resistor R_{PU} value should be chosen in to limit the current through the output pin below the maximum allowed continuous current for the device.
3. A capacitor connected to the output is not obligatory, because the output slope is generated internally.

9. Standard information

Our products are classified and qualified regarding soldering technology, solderability and moisture sensitivity level according to following test methods:

Reflow Soldering SMD's (Surface Mount Device)s

- IPC/JEDEC J-STD-020
Moisture/Reflow Sensitivity Classification for Nonhermetic Solid State Surface Mount Devices (classification reflow profiles according to table 5-2)
- EIA/JEDEC JESD22-A113
Preconditioning of Nonhermetic Surface Mount Devices Prior to Reliability Testing (reflow profiles according to table 2)

Wave Soldering SMD's (Surface Mount Device)s and THD's (Through Hole Device)s

- EN60749-20
Resistance of plastic- encapsulated SMD's to combined effect of moisture and soldering heat
- EIA/JEDEC JESD22-B106 and EN60749-15
Resistance to soldering temperature for through-hole mounted devices

Iron Soldering THD's (Through Hole Device)s

- EN60749-15
Resistance to soldering temperature for through-hole mounted devices

Solderability SMD's (Surface Mount Device)s and THD's (Through Hole Device)s

- EIA/JEDEC JESD22-B102 and EN60749-21
Solderability

For all soldering technologies deviating from above mentioned standard conditions (regarding peak temperature, temperature gradient, temperature profile etc) additional classification and qualification tests have to be agreed upon with Melexis.

The application of Wave Soldering for SMD's is allowed only after consulting Melexis regarding assurance of adhesive strength between device and board.

Melexis is contributing to global environmental conservation by promoting **lead free** solutions. For more information on qualifications of **RoHS** compliant products (RoHS = European directive on the Restriction Of the use of certain Hazardous Substances) please visit the quality page on our website: <http://www.melexis.com/quality.aspx>

10. ESD Precautions

Electronic semiconductor products are sensitive to Electro Static Discharge (ESD).

Always observe Electro Static Discharge control procedures whenever handling semiconductor products.

11. Packages

11.1. TSOT-3L (SE Package)

11.1.1. TSOT-3L – Package dimension

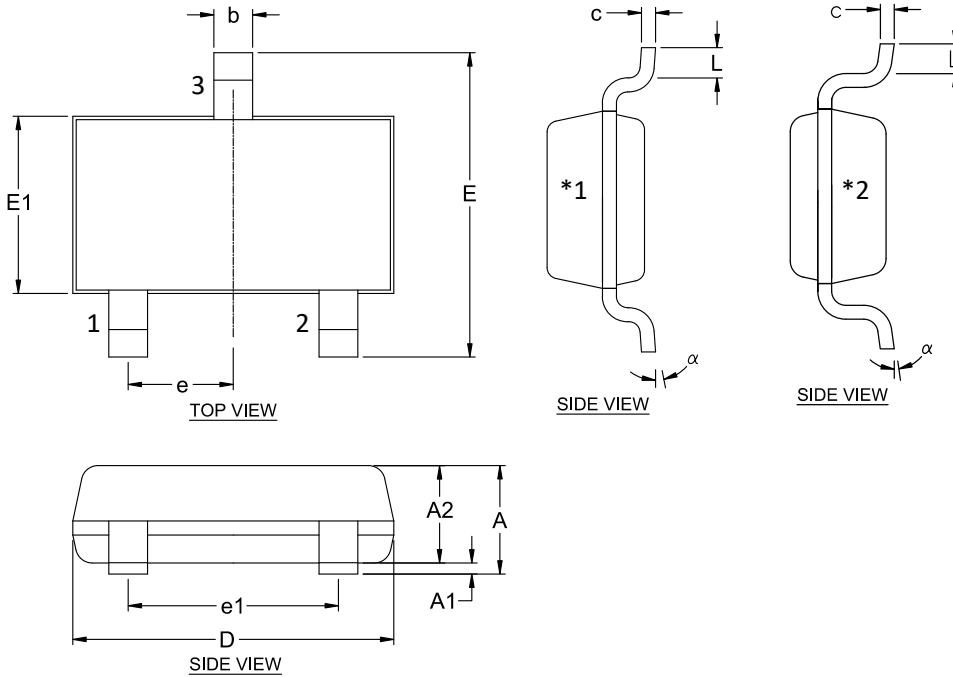

SYMBOL	MINIMUM	MAXIMUM
A	---	1.00
A1	0.025	0.10
A2	0.85	0.90
D	2.80	3.00
E	2.60	3.00
E1	1.50	1.70
L	0.30	0.50
b	0.30	0.45
c	0.10	0.20
e	0.95 BSC	
e1	1.90 BSC	
α	0°	8°

*1 = Valid for AAA, AEA, ACA

*2 = Valid for AFA

NOTE :

1. ALL DIMENSIONS IN MILLIMETERS (mm) UNLESS OTHERWISE STATED.
2. DIMENSION D DOES NOT INCLUDE MOLD FLASH OR PROTRUSIONS OF MAX 0.15 mm PER SIDE.
3. DIMENSION E DOES NOT INCLUDE MOLD FLASH OR PROTRUSIONS OF MAX 0.25 mm PER SIDE.
4. DIMENSION b DOES NOT INCLUDE DAMBAR PROTRUSION OF MAX 0.07 mm.
5. DIMENSION L IS THE LENGTH OF THE TERMINAL FOR SOLDERING TO A SUBSTRATE.
6. FORMED LEAD SHALL BE PLANAR WITH RESPECT TO ONE ANOTHER WITH 0.076 mm SEATING PLANE.

11.1.2. TSOT-3L – Sensitive spot

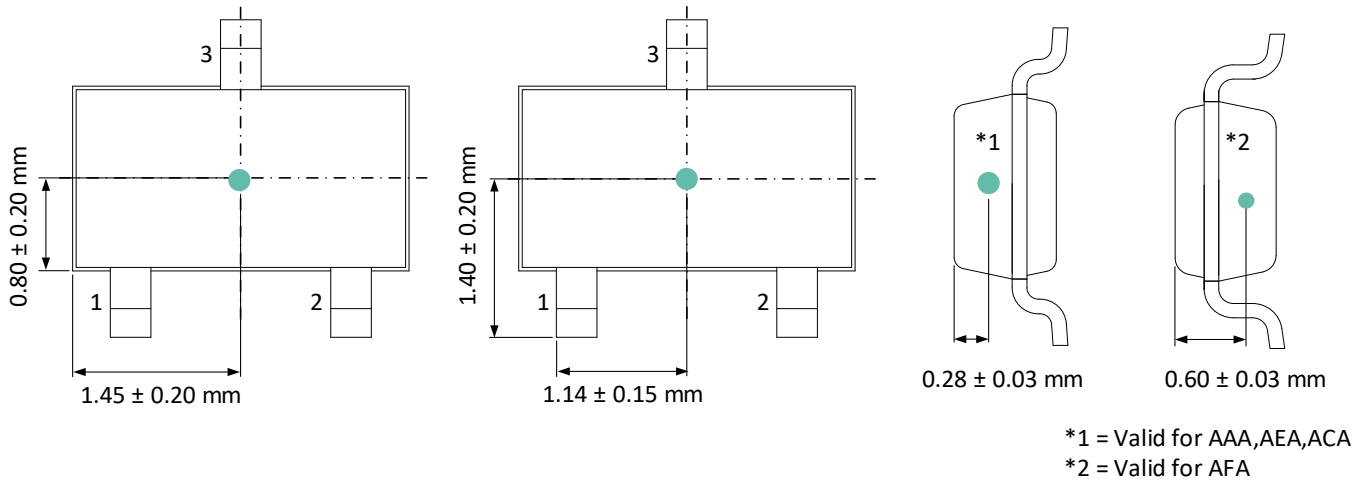

11.1.3. TSOT-3L – Package marking / Pin definition

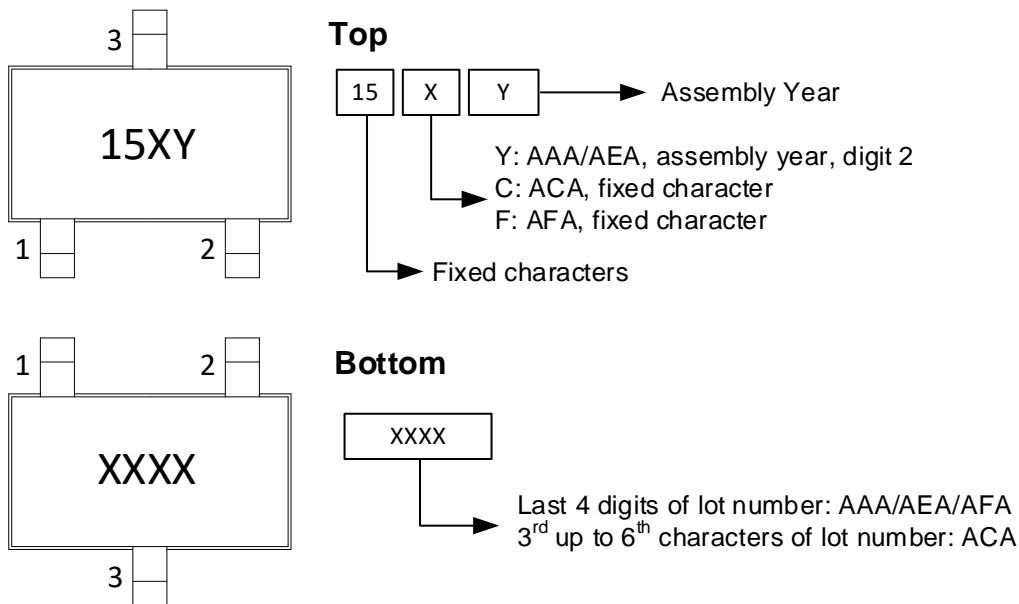

Pin #	Name	Type	Function
1	VDD	Supply	Supply Voltage pin
2	OUT	Out	Open drain output pin
3	GND	Ground	Ground pin

3-Wire Hall Effect Latch

11.2. TO92-3L (UA Package) - For Future Use ¹

11.2.1. TO92-3L – Package dimension

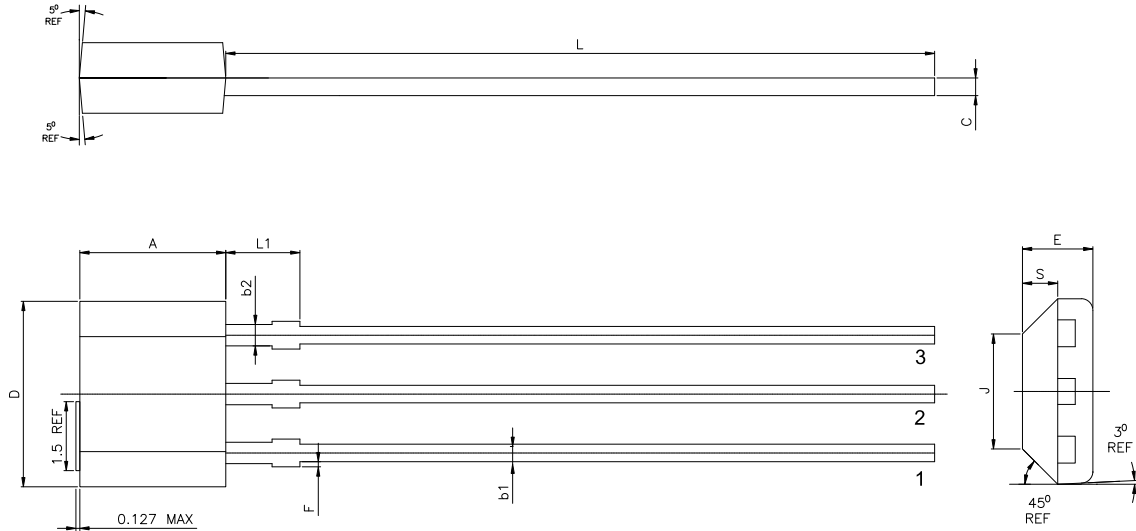

FORM-Y-S	MINIMUM	MAXIMUM
A	3.05	3.25
D	3.90	4.10
E	1.42	1.62
F	---	0.15
J	2.48 REF	
L	15.10	15.50
L1	---	1.75
S	0.66	0.86
b1	0.33	0.48
b2	0.40	0.53
c	0.38	0.43
e	2.54 BSC	
e1	1.27 BSC	

NOTE :

1. DIMENSIONS IN MILLIMETERS (mm) UNLESS NOTED OTHERWISE.
2. PACKAGE DIMENSIONS DO NOT INCLUDE MOLD FLASHES AND PROTRUSIONS.
3. DIMENSION A AND D DO NOT INCLUDE MOLD GATE AND SIDE FLASH (PROTRUSION) OF MAXIMUM 0.127 mm PER SIDE.
4. THE LEADS MAY BE SLIGHTLY DEFORMED DURING TRANSPORTATION IF PACKED IN BULK (BAG), AFFECTING e1 DIMENSION. IT IS RECOMMENDED TO ORDER RADIAL TAPE (REEL OR AMMOPACK) IF SUCH DEFORMATION IS CRITICAL FOR THE LEAD FORMING PROCESS, EVEN IF MANUAL LOADING INTO THE TOOL IS FORESEEN

11.2.2. TO92-3L – Sensitive spot

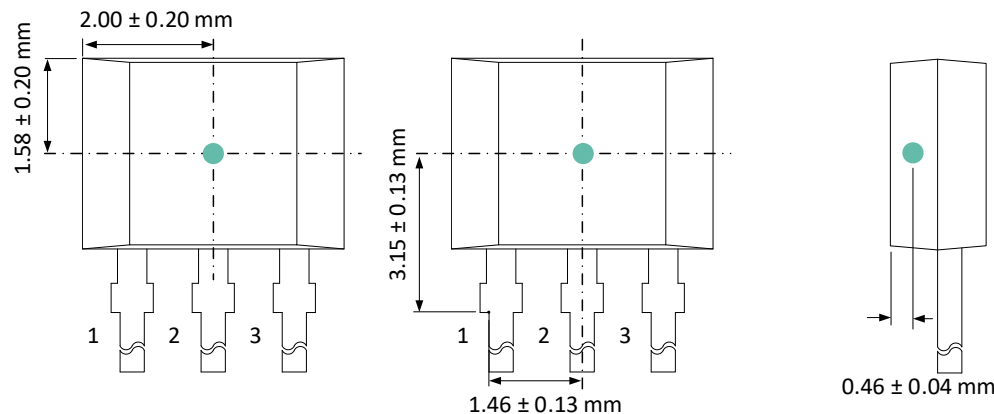

¹ New orders will be supplied with this version of the UA package

11.2.3. TO92-3L – Package marking / Pin definition

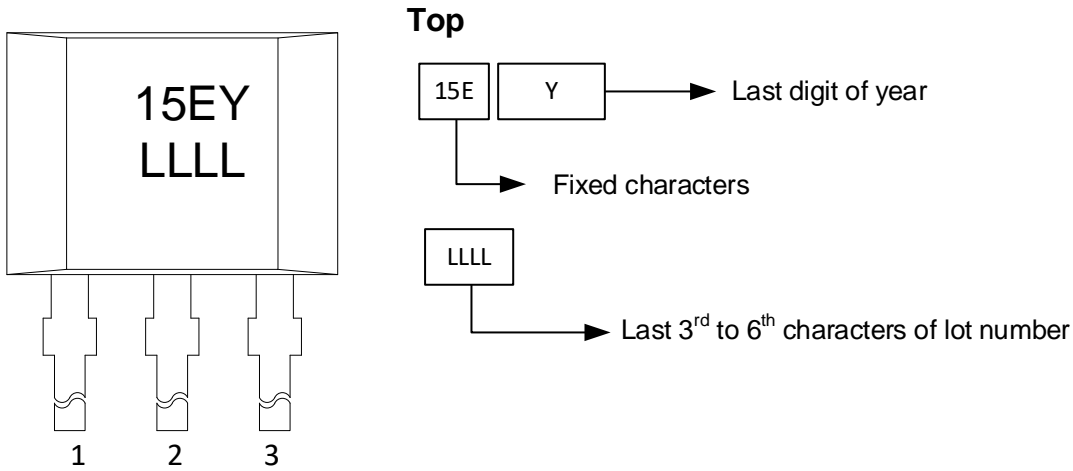

Pin #	Name	Type	Function
1	VDD	Supply	Supply Voltage pin
2	GND	Ground	Ground pin
3	OUT	Out	Open drain output pin

3-Wire Hall Effect Latch

11.3. T092-3L (UA Package) - Not for Future Use

11.3.1. T092-3L – Package dimension

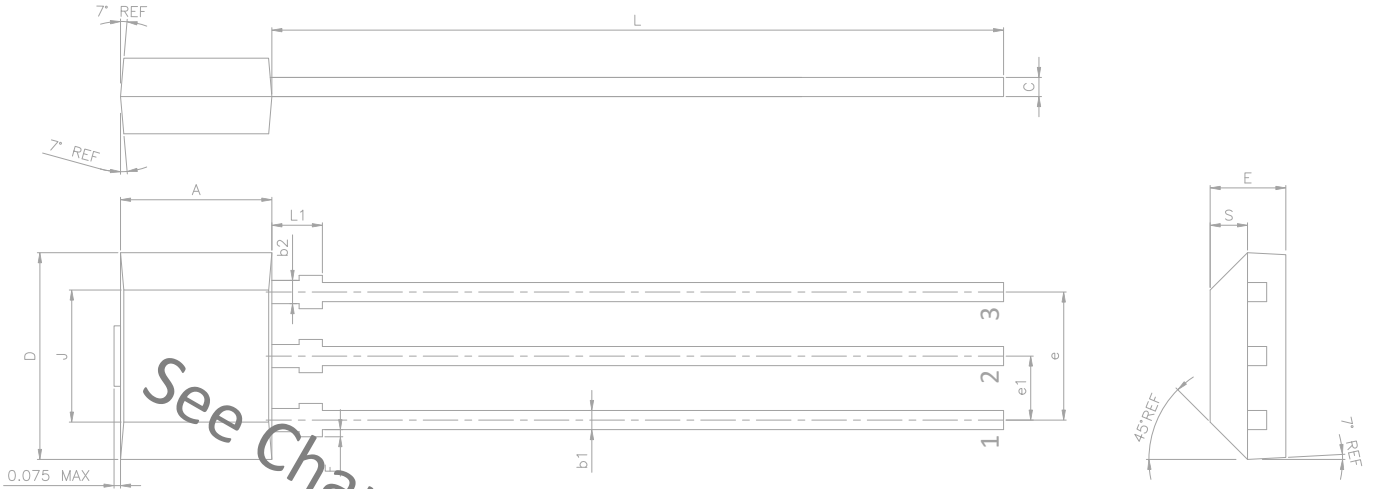

SYMBOL	MINIMUM	MAXIMUM
A	2.90	3.10
D	4.00	4.20
E	1.40	1.60
F	0.00	0.15
J	2.51	2.72
L	14.00	15.00
L1	0.90	1.10
S	0.63	0.84
b1	0.35	0.44
b2	0.43	0.52
c	0.35	0.44
e	2.51	2.57
e1	1.24	1.30

- NOTES :
1. DIMENSIONS IN MILLIMETERS (mm) UNLESS NOTED OTHERWISE.
 2. PACKAGE DIMENSIONS DO NOT INCLUDE MOLD FLASHES AND PROTRUSIONS.
 3. DIMENSION A AND D DO NOT INCLUDE MOLD GATE AND SIDE FLASH (PROTRUSION) of MAXIMUM 0.127 mm PER SIDE.
 4. THE LEADS MAY BE SLIGHTLY DEFORMED DURING TRANSPORTATION IF PACKED IN BULK (BAG), AFFECTING DIMENSION. IT IS RECOMMENDED TO ORDER RADIAL TAKE (REEL OR AMMOPACK) IF SUCH DEFORMATION IS CRITICAL FOR THE LEAD FORMING PROCESS, EVEN IF MANUAL LOADING INTO THE TOOL IS REQUIRED.

11.3.2. T092-3L – Sensitive spot

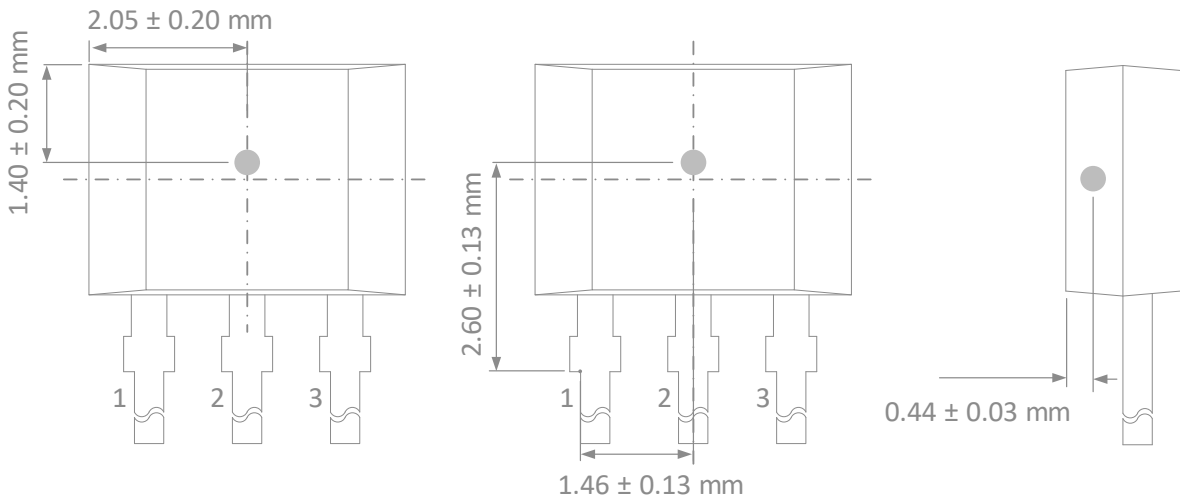

3-Wire Hall Effect Latch

11.3.3. TO92-3L – Package marking / Pin definition

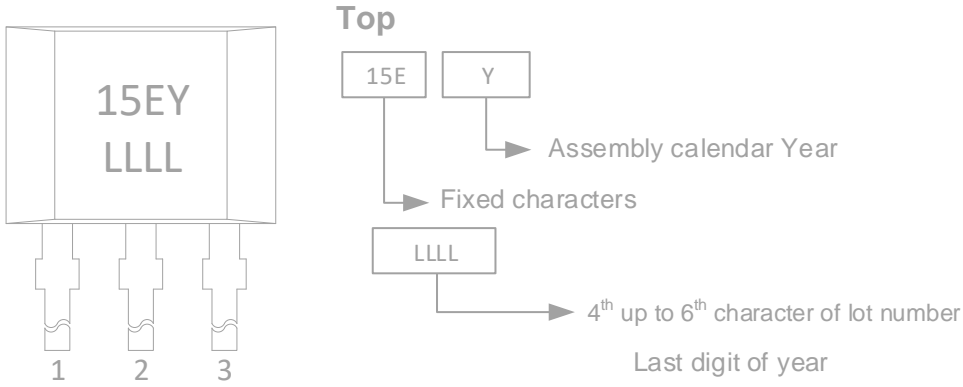

Pin #	Name	Type	Function
1	VDD	Supply	Supply Voltage pin
2	GND	Ground	Ground pin
3	OUT	Out	Open drain output pin

See Chapter 11.2 for the new UA outline

3-Wire Hall Effect Latch

11.4. UTQFN (LD Package)

11.4.1. UTQFN – Package dimension

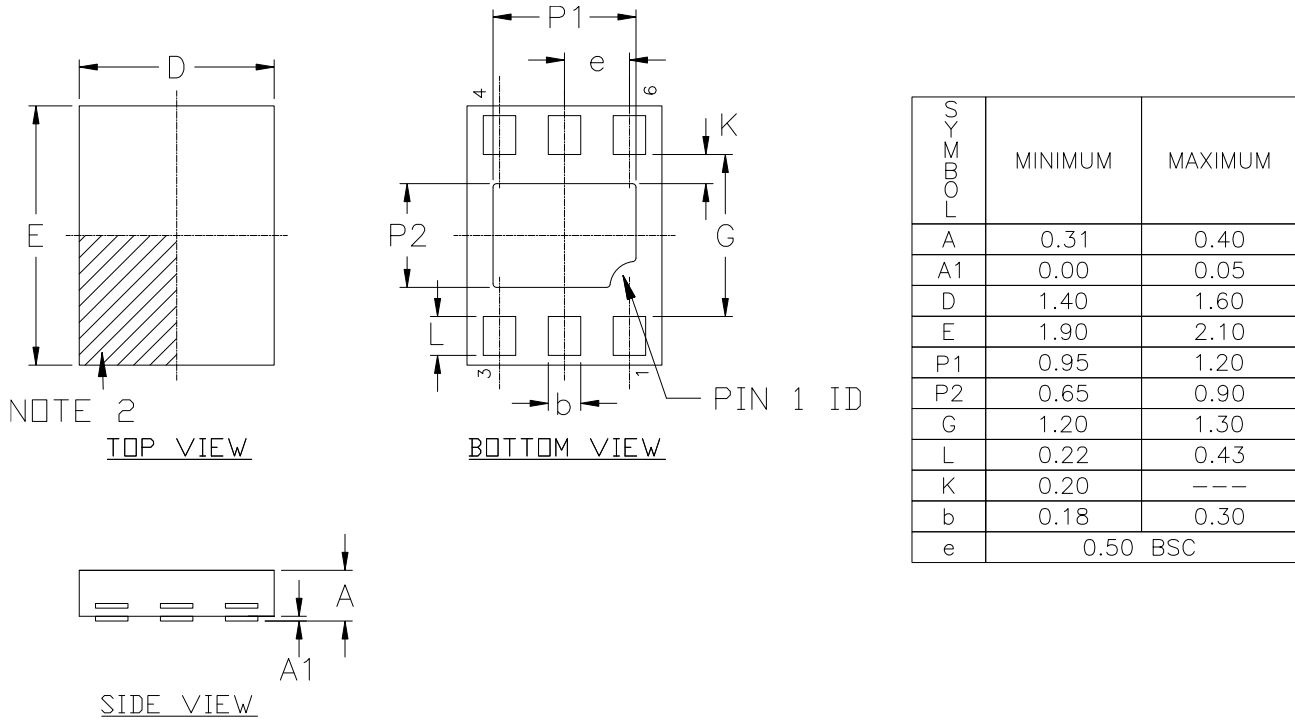

NOTE :

1. ALL DIMENSIONS IN MILLIMETERS (mm).
2. TERMINAL #1 IDENTIFIER AND TERMINAL NUMBERING CONVENTION SHALL CONFORM JEDEC PUBLICATION 95 SPP-002. DETAILS OF TERMINAL #1 IDENTIFIER ARE OPTIONAL, BUT MUST BE LOCATED WITHIN THE ZONE IDENTICATED. THE TERMINAL #1 IDENTIFIER MAY BE MARKED FEATURE.
3. EXPOSED TIE BAR SHOULD BE KEPT FREE FROM SOLDER.

11.4.2. UTQFN – Sensitive spot

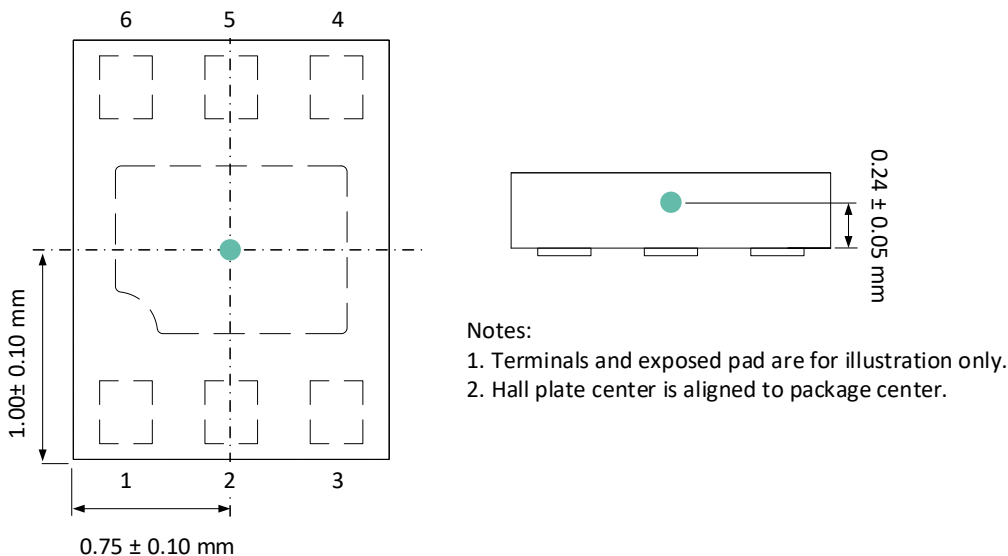

11.4.3. UTQFN – Package marking / Pin definition

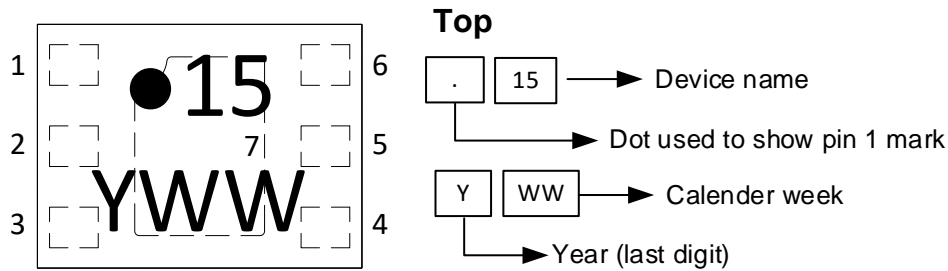

Pin #	Name	Type	Function
1	VDD	Supply	Supply Voltage pin
2,6	N.C.		Not connected
3,4	GND	Ground	Ground pin
5	OUT	Output	Open drain output pin
7	Thermal	Thermal pad	Exposed thermal pad

The exposed pad can be soldered to the PCB to improve thermal dissipation. Can be connected to the ground potential.

3-Wire Hall Effect Latch

11.5. SOT-3L (ST Package)

11.5.1. SOT-3L – Package dimension

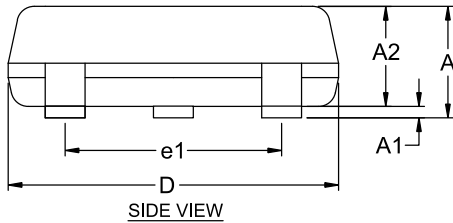
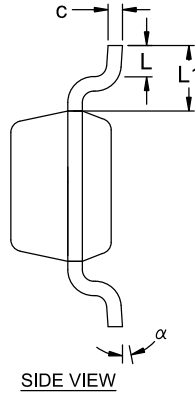
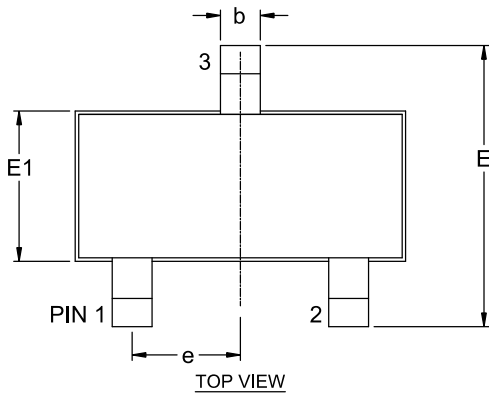

SYMBOL	MINIMUM	MAXIMUM
A	0.89	1.09
A1	0.02	0.08
A2	0.88	1.00
A3	0.41	0.67
A4	0.13	0.38
D	2.80	3.00
E	2.10	2.50
E1	1.19	1.39
L	0.40	0.55
L1	0.54 REF	
b	0.38	0.50
c	0.14	0.16
e	0.95 BSC	
e1	1.90 BSC	
α	0°	5°

NOTE :

1. ALL DIMENSIONS IN MILLIMETERS (mm) UNLESS OTHERWISE STATED.
2. DIMENSION D DOES NOT INCLUDE MOLD FLASH OR PROTRUSIONS OF MAX 0.152 mm PER SIDE.
3. DIMENSION E DOES NOT INCLUDE MOLD FLASH OR PROTRUSIONS OF MAX 0.152 mm PER SIDE.
4. DIMENSION b DOES NOT INCLUDE DAMBAR PROTRUSION OF MAX 0.07 mm.
5. DIMENSION L IS THE LENGTH OF THE TERMINAL FOR SOLDERING TO A SUBSTRATE.
6. FORMED LEAD SHALL BE PLANAR WITH RESPECT TO ONE ANOTHER WITH 0.076 mm SEATING PLANE.

11.5.2. SOT-3L – Sensitive spot

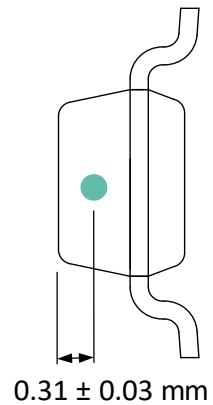
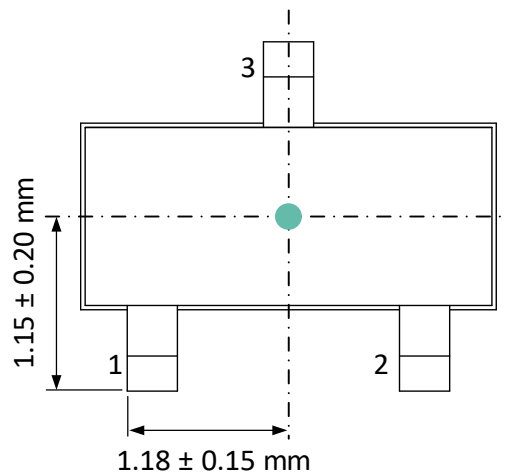
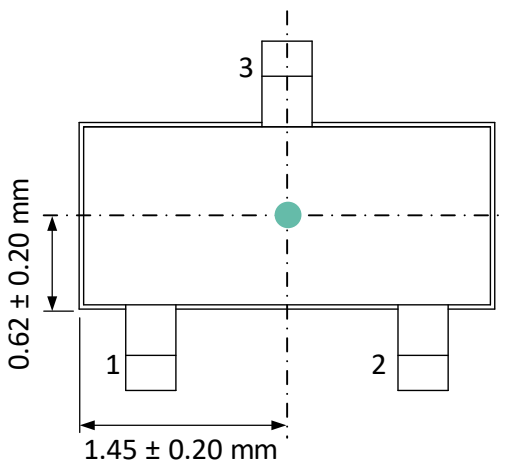

11.5.3. SOT-3L – Package marking / Pin definition

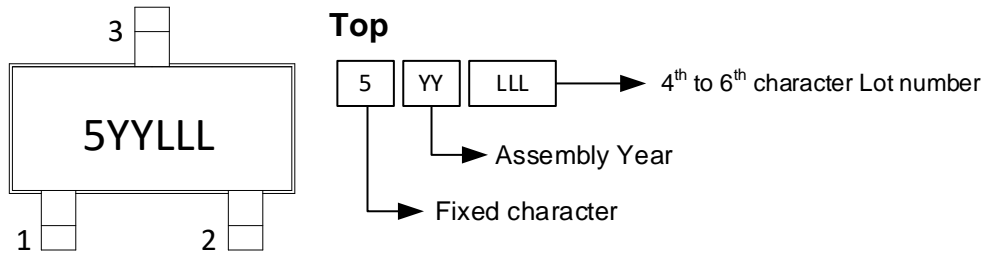

Pin #	Name	Type	Function
1	VDD	Supply	Supply Voltage pin
2	OUT	Output	Open drain output pin
3	GND	Ground	Ground pin

12. Disclaimer

The content of this document is believed to be correct and accurate. However, the content of this document is furnished "as is" for informational use only and no representation, nor warranty is provided by Melexis about its accuracy, nor about the results of its implementation. Melexis assumes no responsibility or liability for any errors or inaccuracies that may appear in this document. Customer will follow the practices contained in this document under its sole responsibility. This documentation is in fact provided without warranty, term, or condition of any kind, either implied or expressed, including but not limited to warranties of merchantability, satisfactory quality, non-infringement, and fitness for purpose. Melexis, its employees and agents and its affiliates¹ and their employees and agents will not be responsible for any loss, however arising, from the use of, or reliance on this document. Notwithstanding the foregoing, contractual obligations expressly undertaken in writing by Melexis prevail over this disclaimer.

This document is subject to change without notice, and should not be construed as a commitment by Melexis. Therefore, before placing orders or prior to designing the product into a system, users or any third party should obtain the latest version of the relevant information. Users or any third party must determine the suitability of the product described in this document for its application, including the level of reliability required and determine whether it is fit for a particular purpose.

This document as well as the product here described may be subject to export control regulations. Be aware that export might require a prior authorization from competent authorities. The product is not designed, authorized or warranted to be suitable in applications requiring extended temperature range and/or unusual environmental requirements. High reliability applications, such as medical life-support or life-sustaining equipment or avionics application are specifically excluded by Melexis. The product may not be used for the following applications subject to export control regulations: the development, production, processing, operation, maintenance, storage, recognition or proliferation of:

- 1. chemical, biological or nuclear weapons, or for the development, production, maintenance or storage of missiles for such weapons;*
- 2. civil firearms, including spare parts or ammunition for such arms;*
- 3. defense related products, or other material for military use or for law enforcement;*
- 4. any applications that, alone or in combination with other goods, substances or organisms could cause serious harm to persons or goods and that can be used as a means of violence in an armed conflict or any similar violent situation.*

No license nor any other right or interest is granted to any of Melexis' or third party's intellectual property rights.

If this document is marked "restricted" or with similar words, or if in any case the content of this document is to be reasonably understood as being confidential, the recipient of this document shall not communicate, nor disclose to any third party, any part of the document without Melexis' express written consent. The recipient shall take all necessary measures to apply and preserve the confidential character of the document. In particular, the recipient shall (i) hold document in confidence with at least the same degree of care by which it maintains the confidentiality of its own proprietary and confidential information, but no less than reasonable care; (ii) restrict the disclosure of the document solely to its employees for the purpose for which this document was received, on a strictly need to know basis and providing that such persons to whom the document is disclosed are bound by confidentiality terms substantially similar to those in this disclaimer; (iii) use the document only in connection with the purpose for which this document was received, and reproduce document only to the extent necessary for such purposes; (iv) not use the document for commercial purposes or to the detriment of Melexis or its customers. The confidentiality obligations set forth in this disclaimer will have indefinite duration and in any case they will be effective for no less than 10 years from the receipt of this document.

This disclaimer will be governed by and construed in accordance with Belgian law and any disputes relating to this disclaimer will be subject to the exclusive jurisdiction of the courts of Brussels, Belgium.

The invalidity or ineffectiveness of any of the provisions of this disclaimer does not affect the validity or effectiveness of the other provisions. The previous versions of this document are repealed.

*Melexis © - No part of this document may be reproduced without the prior written consent of Melexis. (2024)
IATF 16949 and ISO 14001 Certified*





For the latest revision of this document, visit <https://www.melexis.com/MLX92215>
Happy to help you! www.melexis.com/contact

Looking for pricing, stock, or lifecycle information?

Click below to explore more details on WIN SOURCE:

-  [View MLX92215LUA-AAA-000-BU on WIN SOURCE](#)
-  [Melexis Technologies NV Information](#)

Optimize Your Supply Chain with WIN SOURCE Solutions

-  Global Sourcing Solution
-  Obsolete Management
-  Cost Control Management
-  Shortage Management
-  Alternative Solution
-  Excess Inventory Management