



THE DATASHEET OF SS496A1-T3



Linear Hall-effect Sensor ICs: SS490 Series

055843
Issue 2

Datasheet

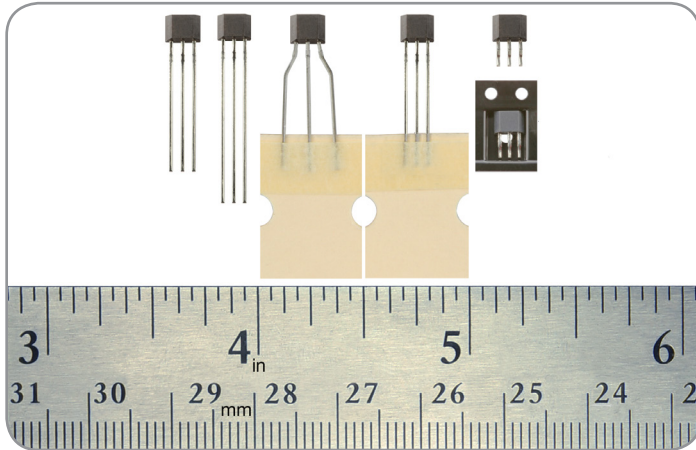

DESCRIPTION

The SS490 Series are small, versatile, linear Hall-effect devices which are operated by the magnetic field from a permanent magnet or an electromagnet. The ratiometric output voltage is set by the supply voltage and varies in proportion to the strength of the magnetic field. The integrated circuitry provides increased temperature stability and sensitivity. Laser-trimmed, thin film resistors provide high accuracy (null to $\pm 0.1\%$, sensitivity up to $\pm 3\%$) and temperature compensation. They respond to either positive or negative Gauss, monitoring either or both magnetic poles. The quad Hall sensing element minimizes the effects of mechanical or thermal stress on the output. The positive temperature coefficient of the sensitivity ($+0.02\%/^{\circ}\text{C}$ typical) helps compensate for the negative temperature coefficients of low-cost magnets, providing a robust design over a wide temperature range. Rail-to-rail operation (over full voltage range) provides a more usable signal for higher accuracy. These products have an operating temperature range of -40°C to 150°C [-40°F to 302°F], appropriate for industrial and automotive environments. The SS490B versions offer cost-effective sensing solutions with wider null and sensitivity tolerances, and a wider drift over temperature than the SS490A higher performance products. Both the SS490A and SS490B versions have a typical sinking or sourcing output of 1.5 mA continuous, use 7 mA supply current at 5.0 V at 25°C [77°F], and provide predictable performance over the full temperature range. For design flexibility, these products are available in the following flat TO-92 package styles:

- **SS4XX**: Straight standard leads, bulk pack
- **SS4XX-L**: Straight long leads, bulk pack
- **SS4XX-T2**: Formed leads, ammopack tape-in-box
- **SS4XX-T3**: Straight standard leads, ammopack tape-in-box
- **SS4XX-S**: Surface mount, bulk pack
- **SS4XX-SP**: Surface mount, pocket tape and reel

FEATURES

- Linear output for circuit design flexibility
- Quad-Hall IC design minimizes mechanical stress effects
- Responds to either positive or negative Gauss
- Uses 7 mA at 5 Vdc for energy efficiency
- Single current sinking or current sourcing output
- Rail-to-rail operation provides more usable signal for higher accuracy
- Temperature-compensated magnetics help provide stable operation over a wide temperature range of -40°C to 150°C [-40°F to 302°F]

POTENTIAL APPLICATIONS

Industrial:

- Basic current sensing for motor load monitoring, detection
- Anti-tampering magnetic field sensor in smart remote utility meters
- Pump control in heavy-duty equipment and household appliances
- Simple linear or angular displacement sensing
- Handlebar/throttle position sensing in e-bikes and scooters
- Current sensing in appliances
- Speed adjustment trigger in tools and appliances
- Magnetic code reading in safes, security and building access control systems

Medical: Position sensing in infusion pumps

PORTFOLIO

The SS490 Series and the SS39ET, SS49E, SS59ET Linear Hall-effect Sensor ICs form Honeywell's Linear Hall-effect Sensor IC offering.

Linear Hall-effect Sensor ICs: SS490 Series

Table 1. General Specifications for All Catalog Listings ($V_s = 5.00\text{ V}$ with 4.7 k output to minus, $T_A = -40^\circ\text{C}$ to 125°C [-40°F to 257°F])

| Characteristic | Condition | Min. | Typ. | Max. | Unit |
|---------------------------------------|---|--------------------|--------------------|-----------|---------------------------------------|
| Supply current | $T_A = 25^\circ\text{C}$ [77°F] | — | 7.0 | 8.7 | mA |
| Output current: sourcing | $V_s > 4.5\text{ V}$ | 1 | 1.5 | — | mA |
| sinking | $V_s > 4.5\text{ V}$ | 0.6 | 1.5 | — | |
| sinking | $V_s > 5.0\text{ V}$ | 1 | 1.5 | — | |
| Response time | — | — | 3 | — | μs |
| Output voltage swing: VOM- VOM+ | -B applied +B applied | 0.4 $V_s - 0.4$ | 0.2 $V_s - 0.2$ | — — | V |
| Supply voltage | $T_A = -40^\circ\text{C}$ to 125°C [-40°F to 257°F] | 4.5 | 5.0 | 10.5 | V |
| Operating temperature | — | -40 [40] | — | 150 [302] | $^\circ\text{C}$ [$^\circ\text{F}$] |
| Soldering temperature and time | wave soldering process: 250°C to 260°C [482°F to 500°F] for 3 s max. infrared reflow process: peak temperature 245°C [473°F] for 10 s max. | | | | |

Table 2. Absolute Maximum Specifications for All Catalog Listings

| Characteristic | Symbol | Condition | Min. | Typ. | Max. | Unit |
|-----------------------|-----------|------------------------|------|------|------|---------------------------------------|
| Supply voltage | V_s | — | -0.5 | — | 11 | V |
| Output voltage | V_{out} | — | -0.5 | — | 11 | V |
| Output current | I_{out} | sourcing or sinking | — | — | 10 | mA |
| Operating temperature | T_A | — | -55 | — | 150 | $^\circ\text{C}$ [$^\circ\text{F}$] |
| Storage temperature | T_s | $V_s = 0$ | -55 | — | 165 | $^\circ\text{C}$ [$^\circ\text{F}$] |

NOTICE

Absolute maximum ratings are the extreme limits the device will momentarily withstand without damage to the device. Electrical and mechanical characteristics are not guaranteed if the rated voltage and/or currents are exceeded, nor will the device necessarily operate at absolute maximum ratings.

NOTICE

The magnetic field strength (Gauss) required to cause the switch to change state (operate and release) will be as specified in the magnetic characteristics. To test the switch against the specified limits, the switch must be placed in a uniform magnetic field.



Table 3. Specifications for Catalog Listing SS494B ($V_s = 5.00\text{ V}$ with 4.7 k output to minus, $T_A = -40^\circ\text{C}$ to 125°C [-40°F to 257°F])

| Characteristic | Condition | Min. | Typ. | Max. | Unit |
|-------------------------------|--|-----------------|--------------|-----------------|---------------------|
| B limits for linear operation | -B max. +B max. | -375 +375 | -420 +420 | — — | Gauss |
| Linearity | $B = -60$ to $+60$ $B = -375$ to $+375$ | — 0 | — -1.0 | — -1.5 | % of span |
| Sensitivity | $T_A = 25^\circ\text{C}$ [77°F] | 4.6 | 5.0 | 5.4 | mV/Gauss |
| Null | $T_A = 25^\circ\text{C}$ [77°F] | 2.26 | 2.50 | 2.74 | V |
| Sensitivity drift | $T_A = -40^\circ\text{C}$ to 25°C [-40°F to 77°F] $T_A = 25^\circ\text{C}$ to 150°C [77°F to 302°F] | 0 -0.02 | — — | +0.08 +0.08 | $\%/^\circ\text{C}$ |
| Vnull drift | $B = 0$; $T_A = -40^\circ\text{C}$ to 125°C [-40°F to 257°F] $B = 0$; $T_A = 125^\circ\text{C}$ to 150°C [257°F to 185°F] | -0.064 -0.02 | — — | +0.064 +0.08 | $\%/^\circ\text{C}$ |

Linear Hall-effect Sensor ICs:

SS490 Series

Table 4. Specifications for Catalog Listings Beginning with SS495 ($V_s = 5.00V$ with 4.7 k output to minus, $T_A = -40^\circ C$ to $125^\circ C$ [$-40^\circ F$ to $257^\circ F$])

| Characteristic | Condition | Min. | Typ. | Max. | Unit |
|-------------------------------|--|----------------|--------------|----------------|-----------|
| SS495A | | | | | |
| B limits for linear operation | -B max. +B max. | -600 +600 | -670 +670 | — — | Gauss |
| Linearity | B = -600 to +600 | 0 | -1.0 | 1.5 | % of span |
| Sensitivity | $T_A = 25^\circ C$ [77°F] | 3.00 | 3.125 | 3.25 | mV/Gauss |
| Null | $T_A = 25^\circ C$ [77°F] | 2.425 | 2.50 | 2.575 | V |
| Sensitivity drift | $T_A = -40^\circ C$ to $25^\circ C$ [-40°F to 77°F] $T_A = 25^\circ C$ to $150^\circ C$ [77°F to 302°F] | 0 -0.01 | — — | +0.06 +0.05 | %/°C |
| Vnull drift | B = 0; $T_A = 25^\circ C$ to $125^\circ C$ [77°F to 257°F] B = 0; $T_A = 125^\circ C$ to $150^\circ C$ [257°F to 302°F] | -0.06 -0.08 | — — | +0.06 +0.08 | %/°C |
| SS495A1 | | | | | |
| B limits for linear operation | -B max. +B max. | -600 +600 | -670 +670 | — — | Gauss |
| Linearity | B = -600 to +600 | 0 | -1.0 | 1.5 | % of span |
| Sensitivity | $T_A = 25^\circ C$ [77°F] | 3.031 | 3.125 | 3.219 | mV/Gauss |
| Null | $T_A = 25^\circ C$ [77°F] | 2.425 | 2.50 | 2.575 | V |
| Sensitivity drift | $T_A = -40^\circ C$ to $25^\circ C$ [-40°F to 77°F] $T_A = 25^\circ C$ to $150^\circ C$ [77°F to 302°F] | 0 -0.01 | — — | +0.06 +0.05 | %/°C |
| Vnull drift | B = 0; $T_A = 25^\circ C$ to $125^\circ C$ [77°F to 257°F] B = 0; $T_A = 125^\circ C$ to $150^\circ C$ [257°F to 302°F] | -0.04 -0.08 | — — | +0.04 +0.08 | %/°C |
| SS495A2 | | | | | |
| B limits for linear operation | -B max. +B max. | -600 +600 | -670 +670 | — — | Gauss |
| Linearity | B = -600 to +600 | 0 | -1.0 | 1.5 | % of span |
| Sensitivity | $T_A = 25^\circ C$ [77°F] | 2.969 | 3.125 | 3.281 | mV/Gauss |
| Null | $T_A = 25^\circ C$ [77°F] | 2.400 | 2.50 | 2.600 | V |
| Sensitivity drift | $T_A = -40^\circ C$ to $25^\circ C$ [-40°F to 77°F] $T_A = 25^\circ C$ to $150^\circ C$ [77°F to 302°F] | -0.01 -0.02 | — — | +0.07 +0.06 | %/°C |
| Vnull drift | B = 0; $T_A = 25^\circ C$ to $125^\circ C$ [77°F to 257°F] B = 0; $T_A = 125^\circ C$ to $150^\circ C$ [257°F to 302°F] | -0.07 -0.08 | — — | +0.07 +0.08 | %/°C |
| SS495B | | | | | |
| B limits for linear operation | -B max. +B max. | -600 +600 | -670 +670 | — — | Gauss |
| Linearity | B = -600 to +600 | 0 | -1.0 | 1.5 | % of span |
| Sensitivity | $T_A = 25^\circ C$ [77°F] | 2.875 | 3.125 | 3.375 | mV/Gauss |
| Null | $T_A = 25^\circ C$ [77°F] | 2.350 | 2.50 | 2.650 | V |
| Sensitivity drift | $T_A = -40^\circ C$ to $25^\circ C$ [-40°F to 77°F] $T_A = 25^\circ C$ to $150^\circ C$ [77°F to 302°F] | -0.02 -0.02 | — — | +0.08 +0.08 | %/°C |
| Vnull drift | B = 0; $T_A = 25^\circ C$ to $125^\circ C$ [77°F to 257°F] B = 0; $T_A = 125^\circ C$ to $150^\circ C$ [257°F to 302°F] | -0.08 -0.08 | — — | +0.08 +0.08 | %/°C |

Linear Hall-effect Sensor ICs: SS490 Series

Table 5. Specifications for Catalog Listings Beginning with SS496 ($V_s = 5.00\text{ V}$ with 4.7 k output to minus, $T_A = -40^\circ\text{C}$ to 125°C [-40°F to 257°F])

| Characteristic | Condition | Min. | Typ. | Max. | Unit |
|-------------------------------|---|---------------------|--------------|-------------------------|-----------|
| SS496A | | | | | |
| B limits for linear operation | -B max. +B max. | -750 +750 | -840 +840 | — — | Gauss |
| Linearity | B = -750 to +750 | 0 | -1.0 | 1.5 | % of span |
| Sensitivity | $T_A = 25^\circ\text{C}$ [77°F] | 2.4 | 2.5 | 2.575 | mV/Gauss |
| Null | $T_A = 25^\circ\text{C}$ [77°F] | 2.425 | 2.50 | 2.575 | V |
| Sensitivity drift | $T_A = -40^\circ\text{C}$ to 25°C [-40°F to 77°F] $T_A = 25^\circ\text{C}$ to 125°C [77°F to 257°F] | 0 -0.01 | — — | +0.06 +0.05 | %/°C |
| Vnull drift | B = 0; $T_A = 25^\circ\text{C}$ to 125°C [77°F to 257°F] B = 0; $T_A = 125^\circ\text{C}$ to 150°C [257°F to 302°F] | -0.048 -0.064 | — — | +0.048 +0.064 | %/°C |
| SS496A1 | | | | | |
| B limits for linear operation | -B max. +B max. | -750 +750 | -840 +840 | — — | Gauss |
| Linearity | B = -750 to +750 | 0 | -1.0 | 1.5 | % of span |
| Sensitivity | $T_A = 25^\circ\text{C}$ [77°F] | 2.425 | 2.500 | 2.575 | mV/Gauss |
| Null | $T_A = 25^\circ\text{C}$ [77°F] | 2.425 | 2.50 | 2.575 | V |
| Sensitivity drift | $T_A = -40^\circ\text{C}$ to 25°C [-40°F to 77°F] $T_A = 25^\circ\text{C}$ to 125°C [77°F to 257°F] $T_A = 125^\circ\text{C}$ to 150°C [257°F to 302°F] | 0 -0.01 -0.04 | — — — | +0.06 +0.05 +0.08 | %/°C |
| Vnull drift | B = 0; $T_A = 25^\circ\text{C}$ to 125°C [77°F to 257°F] B = 0; $T_A = 125^\circ\text{C}$ to 150°C [257°F to 302°F] | -0.032 -0.064 | — — | +0.032 +0.064 | %/°C |
| SS496B | | | | | |
| B limits for linear operation | -B max. +B max. | -750 +750 | -840 +840 | — — | Gauss |
| Linearity | B = -750 to +750 | 0 | -1.0 | 1.5 | % of span |
| Sensitivity | $T_A = 25^\circ\text{C}$ [77°F] | 2.300 | 2.500 | 2.700 | mV/Gauss |
| Null | $T_A = 25^\circ\text{C}$ [77°F] | 2.350 | 2.50 | 2.650 | V |
| Sensitivity drift | $T_A = -40^\circ\text{C}$ to 25°C [-40°F to 77°F] $T_A = 25^\circ\text{C}$ to 150°C [77°F to 302°F] | -0.02 -0.02 | — — | +0.08 +0.08 | %/°C |
| Vnull drift | B = 0; $T_A = 25^\circ\text{C}$ to 125°C [77°F to 257°F] B = 0; $T_A = 125^\circ\text{C}$ to 150°C [257°F to 302°F] | -0.064 -0.064 | — — | +0.064 +0.064 | %/°C |

Figure 1. Block Diagram

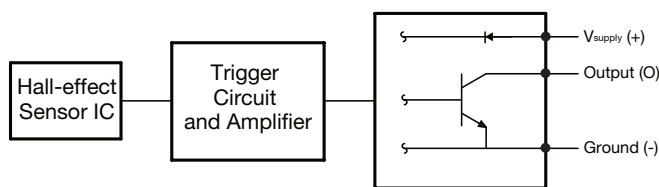

Figure 2. Maximum Supply Voltage vs Temperature

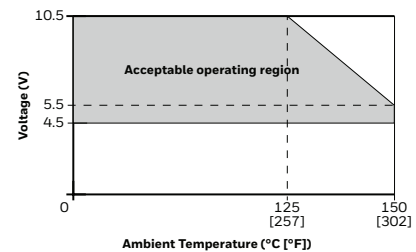
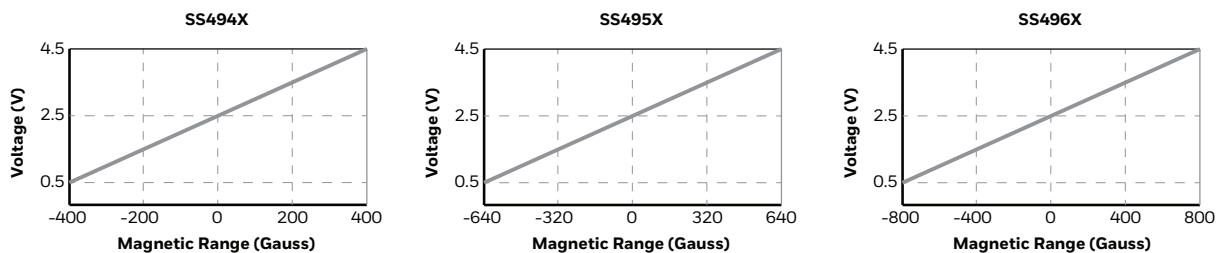

Figure 3. Transfer Characteristics: Typical Output Voltage



Linear Hall-effect Sensor ICs: SS490 Series

Figure 4. SS490 Series Flat TO-92-Style Mounting and Dimensional Drawings (For reference only: mm/[in.])

A: Straight Standard Leads Sensor IC, Bulk Pack

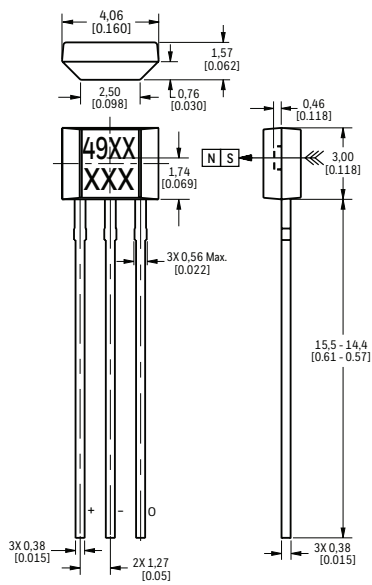

B: Straight Long Leads Sensor IC, Bulk Pack

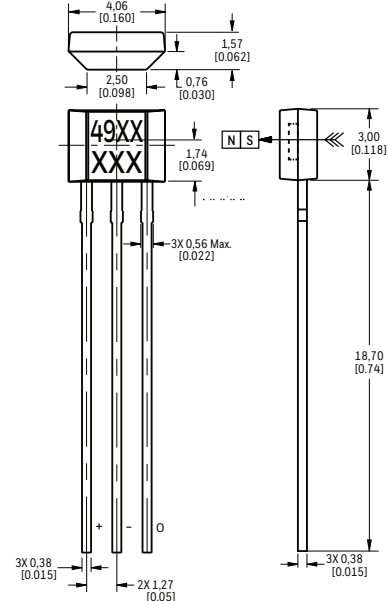

Note: Ensure the minimum hole size in the PCB is 0,68 mm [0.027] dia. based on the IPC 2222 Level B standard.

C. Formed Leads Sensor IC, Ampack Tape-in-Box

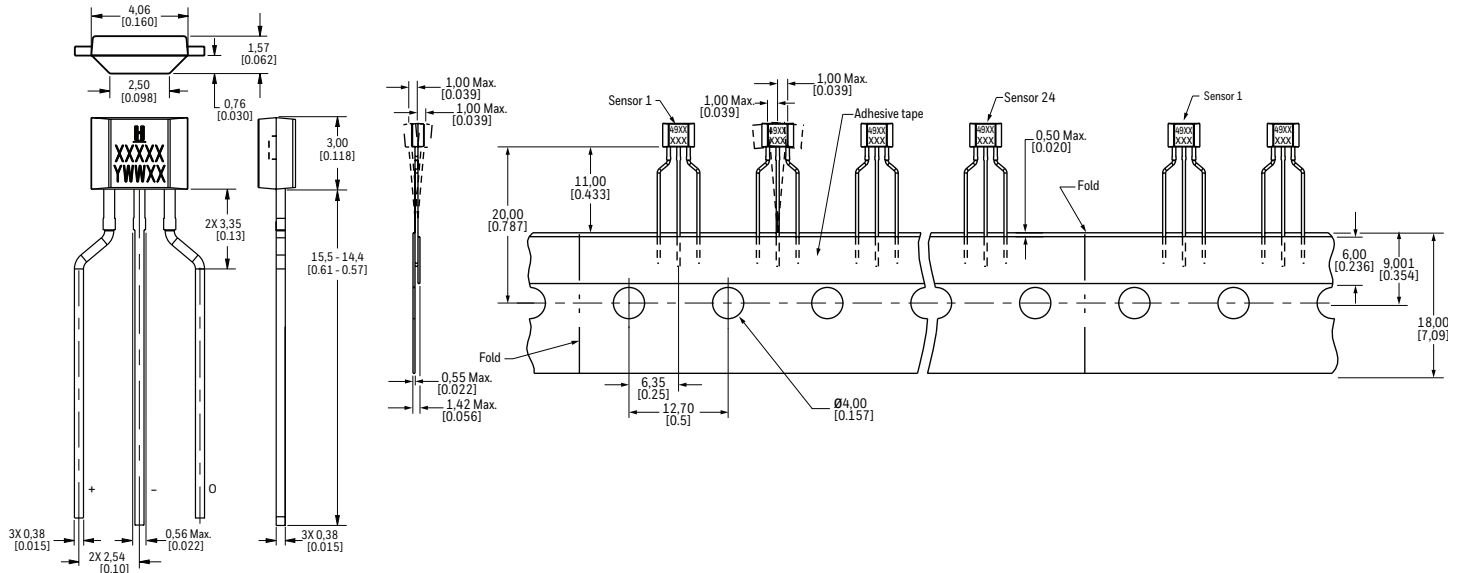

D. Straight Leads Sensor IC, Ampack Tape-in-Box (See Figure 5.A. for individual sensor IC dimensions.)

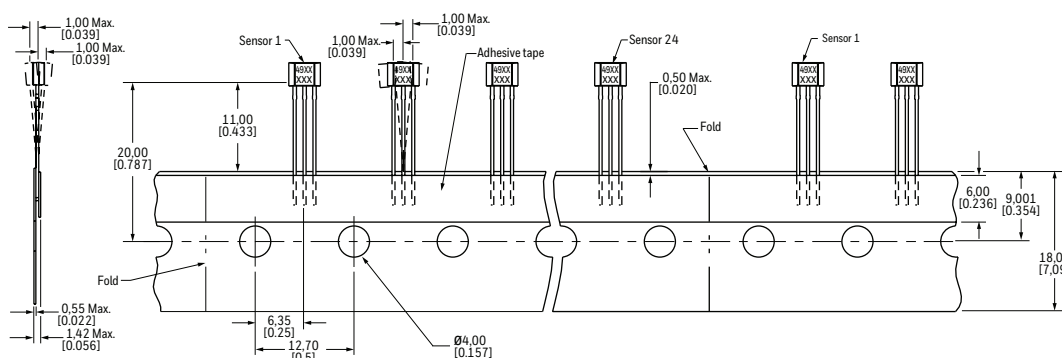

Linear Hall-effect Sensor ICs: SS490 Series

Figure 5. SS490 Series Flat TO-92-Style Mounting and Dimensional Drawings (continued)

E. Surface Mount Sensor IC, Bulk Pack

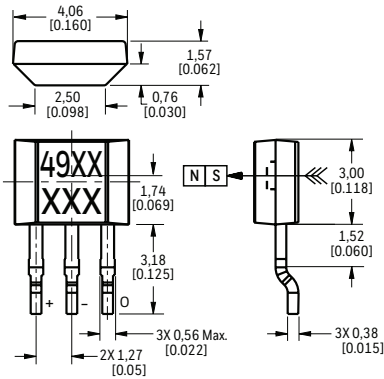

F. Surface Mount Sensor IC, Pocket Tape and Reel (See Figure 5.E. for individual sensor IC dimensions.)

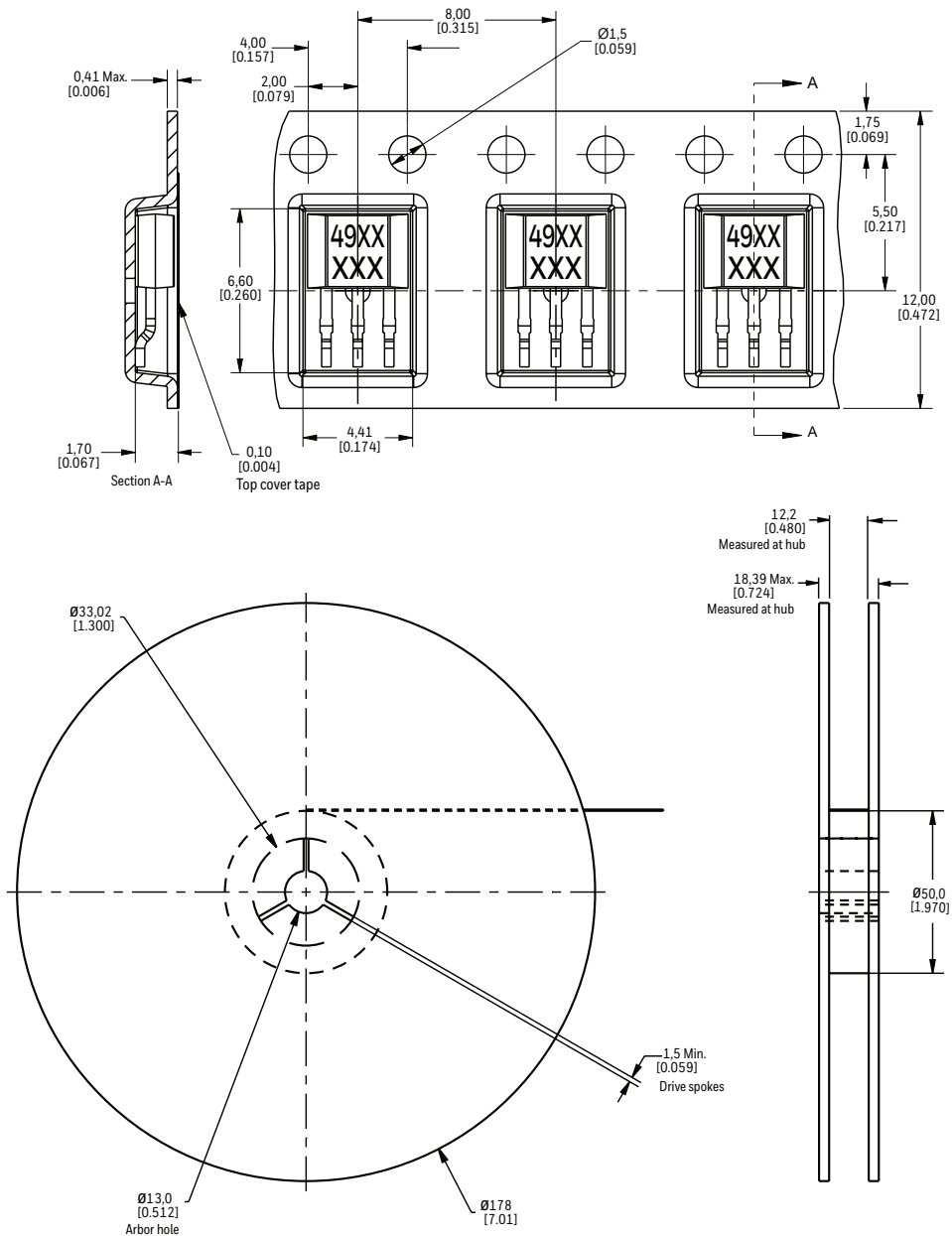

Linear Hall-effect Sensor ICs: SS490 Series

Table 5. Order Guide for the SS490 Series

| Catalog Listing | Description |
|--|--|
| SS49X: Flat TO-92- style, straight standard leads, bulk pack, 1000 units/bag | |
| SS494B | See Tables 1, 2, 3 for specifications; Figure 4.A. for dimensions. |
| SS495A | See Tables 1, 2, 4 for specifications; Figure 4.A. for dimensions. |
| SS495A1 | See Tables 1, 2, 4 for specifications; Figure 4.A. for dimensions. |
| SS495A2 | See Tables 1, 2, 4 for specifications; Figure 4.A. for dimensions. |
| SS495B | See Tables 1, 2, 4 for specifications; Figure 4.A. for dimensions. |
| SS496A | See Tables 1, 2, 5 for specifications; Figure 4.A. for dimensions. |
| SS496A1 | See Tables 1, 2, 5 for specifications; Figure 4.A. for dimensions. |
| SS496B | See Tables 1, 2, 5 for specifications; Figure 4.A. for dimensions. |
| SS49X-L: Flat TO-92- style, straight long leads, bulk pack, 1000 units/bag | |
| SS495A-L | See Tables 1, 2, 4 for specifications; Figure 4.B. for dimensions. |
| SS495A1-L | See Tables 1, 2, 4 for specifications; Figure 4.B. for dimensions. |
| SS495A2-L | See Tables 1, 2, 4 for specifications; Figure 4.B. for dimensions. |
| SS49X-T2: Flat TO-92- style, formed leads, ammpack tape-in-box, 5000 units/box | |
| SS494B-T2 | See Tables 1, 2, 3 for specifications; Figure 4.C. for dimensions. |
| SS495A-T2 | See Tables 1, 2, 4 for specifications; Figure 4.C. for dimensions. |
| SS495A1-T2 | See Tables 1, 2, 4 for specifications; Figure 4.C. for dimensions. |
| SS495A2-T2 | See Tables 1, 2, 4 for specifications; Figure 4.C. for dimensions. |
| SS495B-T2 | See Tables 1, 2, 4 for specifications; Figure 4.C. for dimensions. |
| SS496A-T2 | See Tables 1, 2, 5 for specifications; Figure 4.C. for dimensions. |
| SS496A1-T2 | See Tables 1, 2, 5 for specifications; Figure 4.C. for dimensions. |
| SS496B-T2 | See Tables 1, 2, 5 for specifications; Figure 4.C. for dimensions. |
| SS49X-T3: Flat TO-92- style, straight standard leads, ammpack tape-in-box, 5000 units/box | |
| SS494B-T3 | See Tables 1, 2, 3 for specifications; Figure 4.D. for dimensions. |
| SS495A-T3 | See Tables 1, 2, 4 for specifications; Figure 4.D. for dimensions. |
| SS495A1-T3 | See Tables 1, 2, 4 for specifications; Figure 4.D. for dimensions. |
| SS495A2-T3 | See Tables 1, 2, 4 for specifications; Figure 4.D. for dimensions. |
| SS495B-T3 | See Tables 1, 2, 4 for specifications; Figure 4.D. for dimensions. |
| SS496A-T3 | See Tables 1, 2, 5 for specifications; Figure 4.D. for dimensions. |
| SS496A1-T3 | See Tables 1, 2, 5 for specifications; Figure 4.D. for dimensions. |
| SS496B-T3 | See Tables 1, 2, 5 for specifications; Figure 4.D. for dimensions. |
| SS49X-S: Flat TO-92- style, surface mount, bulk pack, 1000 units/bag | |
| SS494B-S | See Tables 1, 2, 3 for specifications; Figure 4.E. for dimensions. |
| SS495A-S | See Tables 1, 2, 4 for specifications; Figure 4.E. for dimensions. |
| SS495A1-S | See Tables 1, 2, 4 for specifications; Figure 4.E. for dimensions. |
| SS495A2-S | See Tables 1, 2, 4 for specifications; Figure 4.E. for dimensions. |
| SS495B-S | See Tables 1, 2, 4 for specifications; Figure 4.E. for dimensions. |
| SS496A-S | See Tables 1, 2, 5 for specifications; Figure 4.E. for dimensions. |
| SS496A1-S | See Tables 1, 2, 5 for specifications; Figure 4.E. for dimensions. |
| SS496B-S | See Tables 1, 2, 5 for specifications; Figure 4.E. for dimensions. |
| SS49X-SP: Flat TO-92- style, surface mount, pocket tape and reel, 1000 units/reel | |
| SS494B-SP | See Tables 1, 2, 3 for specifications; Figure 4.F. for dimensions. |
| SS495A-SP | See Tables 1, 2, 4 for specifications; Figure 4.F. for dimensions. |
| SS495A1-SP | See Tables 1, 2, 4 for specifications; Figure 4.F. for dimensions. |
| SS495A2-SP | See Tables 1, 2, 4 for specifications; Figure 4.F. for dimensions. |
| SS495B-SP | See Tables 1, 2, 4 for specifications; Figure 4.F. for dimensions. |
| SS496A-SP | See Tables 1, 2, 5 for specifications; Figure 4.F. for dimensions. |
| SS496A1-SP | See Tables 1, 2, 5 for specifications; Figure 4.F. for dimensions. |
| SS496B-SP | See Tables 1, 2, 5 for specifications; Figure 4.F. for dimensions. |

SS49X



SS49X-L



SS49X-T2



SS49X-T3

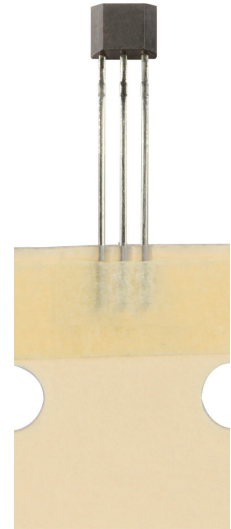

SS49X-S



SS49X-SP

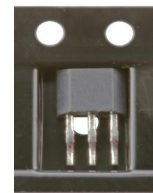

NOTICE

Products ordered in bulk pack (plastic bag) may not have perfectly straight leads as a result of normal handling and shipping operations. Please order a tape packaging option for applications requiring straight leads.

ADDITIONAL MATERIALS

The following associated literature is available at sensing.honeywell.com:

- Product range guide
- Product line guide
- Product installation instructions
- Application notes
- CAD models
- Product images

For more information

Honeywell Sensing and Internet of Things services its customers through a worldwide network of sales offices and distributors. For application assistance, current specifications, pricing or the nearest Authorized Distributor, visit sensing.honeywell.com or call:

| | |
|--------------|---------------------|
| Asia Pacific | +65 6355-2828 |
| Europe | +44 (0) 1698 481481 |
| USA/Canada | +1-800-537-6945 |

Honeywell Sensing and Internet of Things

9680 Old Bailes Road
Fort Mill, SC 29707
www.honeywell.com

WARNING **PERSONAL INJURY**

DO NOT USE these products as safety or emergency stop devices or in any other application where failure of the product could result in personal injury.

Failure to comply with these instructions could result in death or serious injury.

WARNING **MISUSE OF DOCUMENTATION**

- The information presented in this product sheet is for reference only. Do not use this document as a product installation guide.
- Complete installation, operation, and maintenance information is provided in the instructions supplied with each product.

Failure to comply with these instructions could result in death or serious injury.

Warranty/Remedy

Honeywell warrants goods of its manufacture as being free of defective materials and faulty workmanship during the applicable warranty period. Honeywell's standard product warranty applies unless agreed to otherwise by Honeywell in writing; please refer to your order acknowledgment or consult your local sales office for specific warranty details. If warranted goods are returned to Honeywell during the period of coverage, Honeywell will repair or replace, at its option, without charge those items that Honeywell, in its sole discretion, finds defective. **The foregoing is buyer's sole remedy and is in lieu of all other warranties, expressed or implied, including those of merchantability and fitness for a particular purpose. In no event shall Honeywell be liable for consequential, special, or indirect damages.**

While Honeywell may provide application assistance personally, through our literature and the Honeywell web site, it is buyer's sole responsibility to determine the suitability of the product in the application.

Specifications may change without notice. The information we supply is believed to be accurate and reliable as of this writing. However, Honeywell assumes no responsibility for its use.

Looking for pricing, stock, or lifecycle information?

Click below to explore more details on WIN SOURCE:

 [View SS496A1-T3 on WIN SOURCE](#)

 [Honeywell Information](#)

Optimize Your Supply Chain with WIN SOURCE Solutions

-  Global Sourcing Solution
-  Obsolete Management
-  Cost Control Management
-  Shortage Management
-  Alternative Solution
-  Excess Inventory Management