



THE DATASHEET OF CY2304SXI-2



3.3 V Zero Delay Buffer

Features

- Zero input-output propagation delay, adjustable by capacitive load on FBK input
- Multiple configurations
- Multiple low-skew outputs
- 10 MHz to 133 MHz operating range
- 90 ps typical peak cycle-to-cycle jitter at 15 pF, 66 MHz
- Space-saving 8-pin 150-mil small outline integrated circuit (SOIC) package
- 3.3 V operation
- Industrial temperature available

Functional Description

The CY2304 is a 3.3 V zero delay buffer designed to distribute high-speed clocks in PC, workstation, datacom, telecom, and other high performance applications.

The part has an on-chip phase-locked loop (PLL) that locks to an input clock presented on the REF pin. The PLL feedback is

required to be driven into the FBK pin, and can be obtained from one of the outputs. The input-to-output skew is guaranteed to be less than 250 ps, and output-to-output skew is guaranteed to be less than 200 ps.

The CY2304 has two banks of two outputs each.

The CY2304 PLL enters a power down state when there are no rising edges on the REF input. In this mode, all outputs are three-stated and the PLL is turned off, resulting in less than 25 μ A of current draw.

Multiple CY2304 devices can accept the same input clock and distribute it in a system. In this case, the skew between the outputs of two devices is guaranteed to be less than 500 ps.

The CY2304 is available in two different configurations, as shown in [Available Configurations](#). The CY2304-1 is the base part, where the output frequencies equal the reference if there is no counter in the feedback path.

The CY2304-2 allows the user to obtain Ref and 1/2x or 2x frequencies on each output bank. The exact configuration and output frequencies depends on which output drives the feedback pin.

For a complete list of related documentation, click [here](#).

Logic Block Diagram

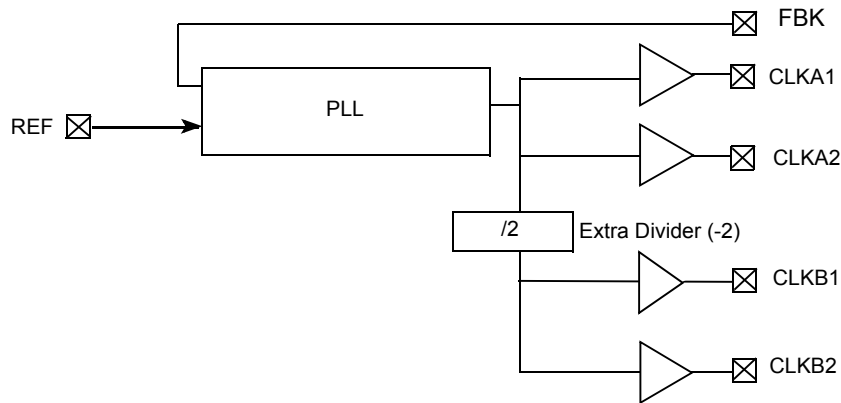

Available Configurations

Device	FBK from	Bank A Frequency	Bank B Frequency
CY2304-1	Bank A or B	Reference	Reference
CY2304-2	Bank A	Reference	Reference/2
CY2304-2	Bank B	2 × Reference	Reference

Contents

Pin Configurations	3	Acronyms	13
Pin Definitions	3	Document Conventions	13
Zero Delay and Skew Control	4	Units of Measure	13
Maximum Ratings	5	Appendix: Silicon Errata for	
Operating Conditions	5	the Zero Delay Clock Buffers, CY2304	14
Electrical Characteristics	5	Part Numbers Affected	14
Switching Characteristics	6	CY2304 Errata Summary	14
Operating Conditions	7	CY2303 Qualification Status of fixed silicon	14
Electrical Characteristics	7	Document History Page	16
Thermal Resistance	8	Sales, Solutions, and Legal Information	17
Test Circuit	8	Worldwide Sales and Design Support	17
Switching Characteristics	9	Products	17
Switching Waveforms	10	PSoC® Solutions	17
Ordering Information	11	Cypress Developer Community	17
Ordering Code Definitions	11	Technical Support	17
Package Diagram	12		

Pin Configurations

Figure 1. 8-pin SOIC pinout

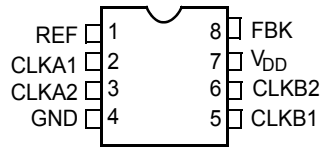

Pin Definitions

8-pin SOIC

Pin	Signal	Description
1	REF ^[1]	Input reference frequency, 5 V tolerant input
2	CLKA1 ^[2]	Clock output, Bank A
3	CLKA2 ^[2]	Clock output, Bank A
4	GND	Ground
5	CLKB1 ^[2]	Clock output, Bank B
6	CLKB2 ^[2]	Clock output, Bank B
7	V _{DD}	3.3 V supply
8	FBK	PLL feedback input

Notes

1. Weak pull-down.
2. Weak pull-down on all outputs.

Zero Delay and Skew Control

Figure 2. REF. Input to CLKA/CLKB Delay vs. Difference in Loading Between FBK Pin and CLKA/CLKB Pins

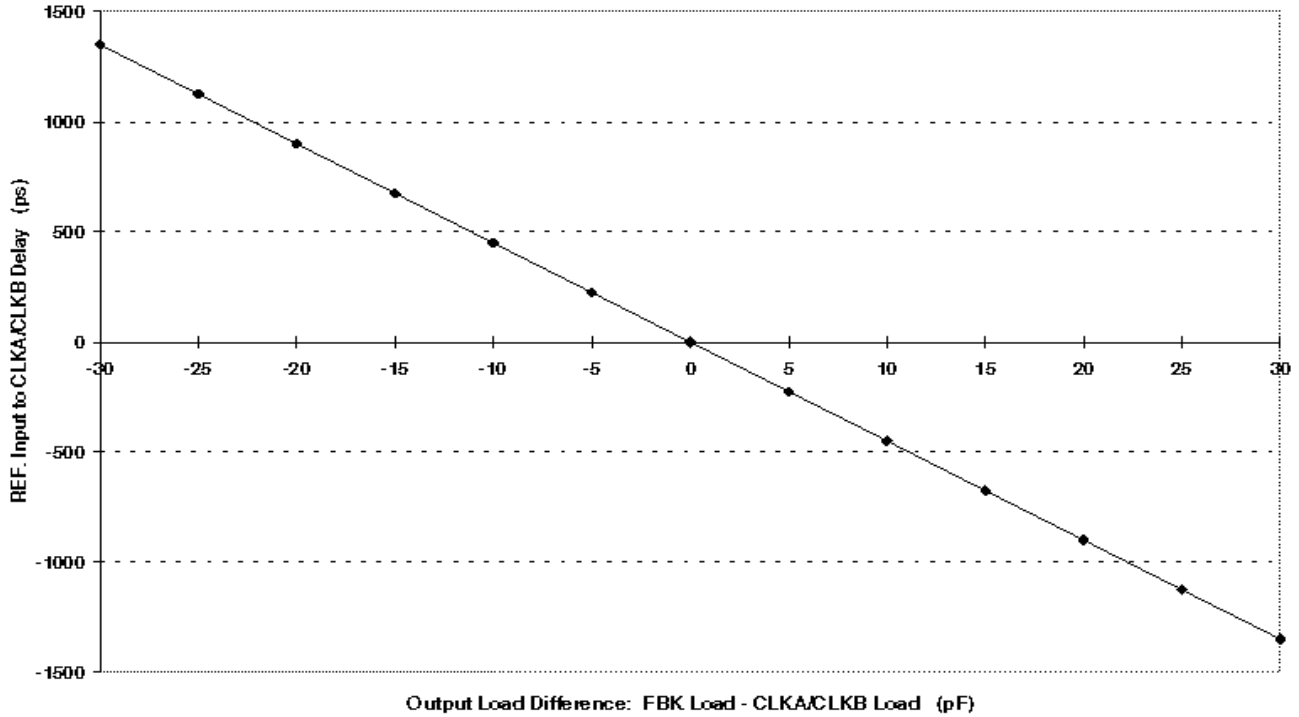

To close the feedback loop of the CY2304, the FBK pin can be driven from any of the four available output pins. The output driving the FBK pin is driving a total load of 7 pF, with any additional load that it drives. The relative loading of this output (with respect to the remaining outputs) can adjust the input-output delay. This is shown in [Figure 2](#).

For applications requiring zero input-output delay, all outputs including the one providing feedback must be equally loaded. If input-output delay adjustments are required, use the graph shown in [Figure 2](#) to calculate loading differences between the feedback output and remaining outputs.

For zero output-output skew, be sure to load outputs equally. For further information on using CY2304, refer to the application note [AN1234 - Understanding Cypress's Zero Delay Buffers](#).

Maximum Ratings

Supply voltage to ground potential -0.5 V to +7.0 V
 DC input voltage (except Ref) -0.5 V to $V_{DD} + 0.5$ V
 DC input voltage REF -0.5 V to 7 V

Storage temperature -65 °C to +150 °C
 Junction temperature 150 °C
 Static discharge voltage
 (per MIL-STD-883, Method 3015) > 2000 V

Operating Conditions

For CY2304SXC Commercial Temperature Devices

Parameter	Description	Min	Max	Unit
V_{DD}	Supply voltage	3.0	3.6	V
T_A	Operating temperature (ambient temperature)	0	70	°C
C_L	Load capacitance (below 100 MHz)	–	30	pF
	Load capacitance (from 100 MHz to 133 MHz)	–	15	pF
C_{IN}	Input capacitance ^[3]	–	7	pF
t_{PU}	Power-up time for all V_{DD} s to reach minimum specified voltage (power ramps must be monotonic)	0.05	50	ms

Electrical Characteristics

For CY2304SXC Commercial Temperature Devices

Parameter	Description	Test Conditions	Min	Max	Unit
V_{IL}	Input LOW voltage		–	0.8	V
V_{IH}	Input HIGH voltage		2.0	–	V
I_{IL}	Input LOW current	$V_{IN} = 0$ V	–	50.0	μA
I_{IH}	Input HIGH current	$V_{IN} = V_{DD}$	–	100.0	μA
V_{OL}	Output LOW voltage ^[4]	$I_{OL} = 8$ mA (-1, -2)	–	0.4	V
V_{OH}	Output HIGH voltage ^[4]	$I_{OH} = -8$ mA (-1, -2)	2.4	–	V
I_{DD} (PD mode)	Power-down supply current	REF = 0 MHz	–	12.0	μA
I_{DD}	Supply current	Unloaded outputs, 100 MHz REF, Select inputs at V_{DD} or GND	–	45.0	mA
		Unloaded outputs, 66 MHz REF (-1, -2)	–	32.0	mA
		Unloaded outputs, 33 MHz REF (-1, -2)	–	18.0	mA

Notes

- Applies to both REF clock and FBK.
- Parameter is guaranteed by design and characterization. Not 100% tested in production.

Switching Characteristics

For CY2304SXC Commercial Temperature Devices

Parameter ^[5]	Name	Test Conditions	Min	Typ	Max	Unit
t ₁	Output frequency	30 pF load, all devices	10	–	100	MHz
t ₁	Output frequency	15 pF load, -1, -2 devices	10	–	133.3	MHz
t _{DC}	Duty cycle ^[6] = t ₂ ÷ t ₁ (-1, -2)	Measured at 1.4 V, F _{OUT} = 66.66 MHz, 30-pF load	40.0	50.0	60.0	%
t _{DC}	Duty cycle ^[6] = t ₂ ÷ t ₁ (-2)	Measured at 1.4 V, F _{OUT} = 83.0 MHz, 15-pF load	40.0	50.0	60.0	%
t _{DC}	Duty cycle ^[6] = t ₂ ÷ t ₁ (-1, -2)	Measured at 1.4 V, F _{OUT} < 50 MHz, 15-pF load	45.0	50.0	55.0	%
t ₃	Rise time ^[6] (-1, -2)	Measured between 0.8 V and 2.0 V, 30-pF load	–	–	2.20	ns
t ₃	Rise time ^[6] (-1, -2)	Measured between 0.8 V and 2.0 V, 15-pF load	–	–	1.50	ns
t ₄	Fall time ^[6] (-1, -2)	Measured between 0.8 V and 2.0 V, 30-pF load	–	–	2.20	ns
t ₄	Fall time ^[6] (-1, -2)	Measured between 0.8 V and 2.0 V, 15 pF load	–	–	1.50	ns
t ₅	Output-to-output skew on same Bank (-1, -2) ^[6]	All outputs equally loaded	–	–	200	ps
	Output bank A to output bank B skew (-1)	All outputs equally loaded	–	–	200	ps
	Output bank A to output bank B skew (-2)	All outputs equally loaded	–	–	400	ps
t ₆	Skew, REF rising edge to FBK rising edge ^[6]	Measured at V _{DD} /2	–	0	±250	ps
t ₇	Device-to-device skew ^[6]	Measured at V _{DD} /2 on the FBK pins of devices	–	0	500	ps
t _J	Cycle-to-cycle jitter ^[6] (-1)	Measured at 66.67 MHz, loaded outputs, 15-pF load	–	90	175	ps
		Measured at 66.67 MHz, loaded outputs, 30-pF load	–	–	200	ps
		Measured at 133.3 MHz, loaded outputs, 15-pF load	–	–	100	ps
t _J	Cycle-to-cycle jitter ^[6] (-2)	Measured at 66.67 MHz, loaded outputs 30-pF load	–	–	400	ps
		Measured at 66.67 MHz, loaded outputs 15-pF load	–	–	375	ps
t _{LOCK}	PLL lock time ^[6]	Stable power supply, valid clocks presented on REF and FBK pins	–	–	1.0	ms

Notes

5. All parameters are specified with loaded output.
6. Parameter is guaranteed by design and characterization. Not 100% tested in production.

Operating Conditions

For CY2304SXI Industrial Temperature Devices

Parameter	Description	Min	Max	Unit
V _{DD}	Supply voltage	3.0	3.6	V
T _A	Operating temperature (ambient temperature)	-40	85	°C
C _L	Load capacitance (below 100 MHz)	-	30	pF
	Load capacitance (from 100 MHz to 133 MHz)	-	15	pF
C _{IN}	Input capacitance	-	7	pF

Electrical Characteristics

For CY2304SXI Industrial Temperature Devices

Parameter	Description	Test Conditions	Min	Max	Unit
V _{IL}	Input LOW voltage		-	0.8	V
V _{IH}	Input HIGH voltage		2.0	-	V
I _{IL}	Input LOW current	V _{IN} = 0 V	-	50.0	μA
I _{IH}	Input HIGH current	V _{IN} = V _{DD}	-	100.0	μA
V _{OL}	Output LOW voltage ^[7]	I _{OL} = 8 mA (-1, -2)	-	0.4	V
V _{OH}	Output HIGH voltage ^[7]	I _{OH} = -8 mA (-1, -2)	2.4	-	V
I _{DD} (PD mode)	Power-down supply current	REF = 0 MHz	-	25.0	μA
I _{DD}	Supply current	Unloaded outputs, 100 MHz, Select inputs at V _{DD} or GND	-	45.0	mA
		Unloaded outputs, 66 MHz REF (-1, -2)	-	35.0	mA
		Unloaded outputs, 33 MHz REF (-1, -2)	-	20.0	mA

Note

7. Parameter is guaranteed by design and characterization. Not 100% tested in production.

Thermal Resistance

Parameter ^[8]	Description	Test Conditions	8-pin SOIC	Unit
θ_{JA}	Thermal resistance (junction to ambient)	Test conditions follow standard test methods and procedures for measuring thermal impedance, in accordance with EIA/JESD51.	140	°C/W
θ_{JC}	Thermal resistance (junction to case)		54	°C/W

Test Circuit

Figure 3. Test Circuit # 1

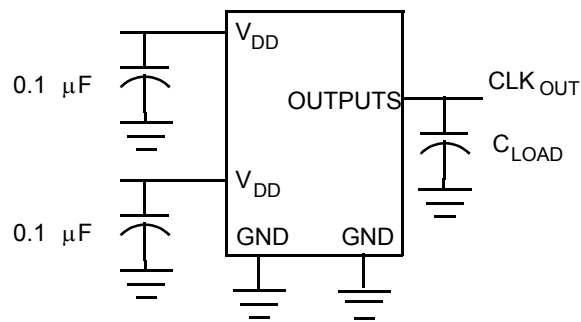

Test circuit for all parameters

Note

8. These parameters are guaranteed by design and are not tested.

Switching Characteristics

for CY2304SXI Industrial Temperature Devices

Parameter ^[9]	Name	Test Conditions	Min	Typ	Max	Unit
t ₁	Output frequency	30-pF load, All devices	10	–	100	MHz
t ₁	Output frequency	15-pF load, All devices	10	–	133.3	MHz
t _{DC}	Duty cycle ^[10] = t ₂ ÷ t ₁ (-1, -2)	Measured at 1.4 V, F _{OUT} = 66.66 MHz, 30-pF load	40.0	50.0	60.0	%
t _{DC}	Duty cycle ^[10] = t ₂ ÷ t ₁ (-2)	Measured at 1.4 V, F _{OUT} = 83.0 MHz, 15-pF load	40.0	50.0	60.0	%
t _{DC}	Duty cycle ^[10] = t ₂ ÷ t ₁ (-1, -2)	Measured at 1.4 V, F _{OUT} < 50 MHz, 15-pF load	45.0	50.0	55.0	%
t ₃	Rise time ^[10] (-1, -2)	Measured between 0.8 V and 2.0 V, 30-pF load	–	–	2.50	ns
t ₃	Rise time ^[10] (-1, -2)	Measured between 0.8 V and 2.0 V, 15-pF load	–	–	1.50	ns
t ₄	Fall time ^[10] (-1, -2)	Measured between 0.8 V and 2.0 V, 30-pF load	–	–	2.50	ns
t ₄	Fall time ^[10] (-1, -2)	Measured between 0.8 V and 2.0 V, 15-pF load	–	–	1.50	ns
t ₅	Output-to-output skew on same bank (-1, -2) ^[10]	All outputs equally loaded	–	–	200	ps
	Output bank A to output bank B skew (-1)	All outputs equally loaded	–	–	200	ps
	Output bank A to output bank B skew (-2)	All outputs equally loaded	–	–	400	ps
t ₆	Skew, REF rising edge to FBK rising edge ^[10]	Measured at V _{DD} /2	–	0	±250	ps
t ₇	Device-to-device skew ^[10]	Measured at V _{DD} /2 on the FBK pins of devices	–	0	500	ps
t _J	Cycle-to-cycle jitter ^[10] (-1)	Measured at 66.67 MHz, loaded outputs, 15-pF load	–	–	180	ps
		Measured at 66.67 MHz, loaded outputs, 30-pF load	–	–	200	ps
		Measured at 133.3 MHz, loaded outputs, 15-pF load	–	–	100	ps
t _J	Cycle-to-cycle jitter ^[10] (-2)	Measured at 66.67 MHz, loaded outputs, 30-pF load	–	–	400	ps
		Measured at 66.67 MHz, loaded outputs, 15-pF load	–	–	380	ps
t _{LOCK}	PLL lock time ^[10]	Stable power supply, valid clocks presented on REF and FBK pins	–	–	1.0	ms

Notes

9. All parameters are specified with loaded output.
 10. Parameter is guaranteed by design and characterization. Not 100% tested in production.

Switching Waveforms

Figure 4. Duty Cycle Timing

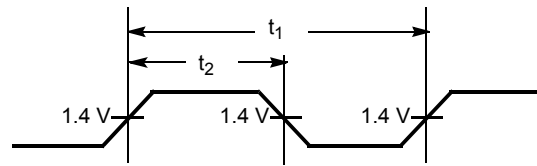

Figure 5. All Outputs Rise/Fall Time

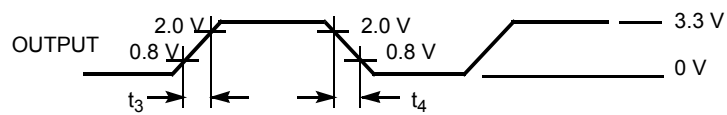

Figure 6. Output-Output Skew

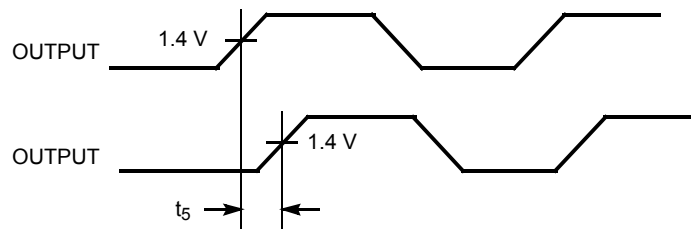

Figure 7. Input-Output Skew

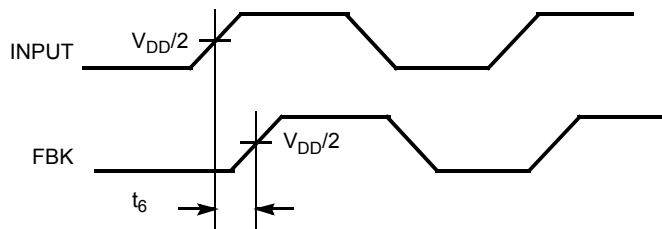
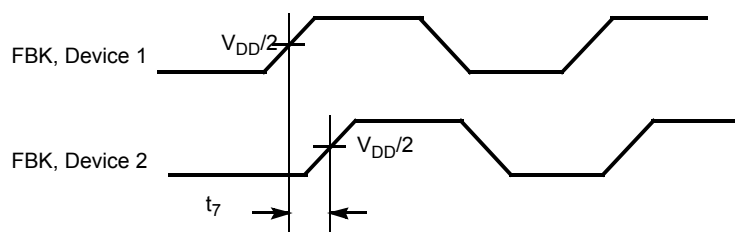

Figure 8. Device-Device Skew



Ordering Information

Ordering Code	Package Type	Operating Range
Pb-free		
CY2304SXC-1	8-pin SOIC (150 Mils)	Commercial
CY2304SXC-1T	8-pin SOIC (150 Mils) – Tape and Reel	Commercial
CY2304SXI-1	8-pin SOIC (150 Mils)	Industrial
CY2304SXI-1T	8-pin SOIC (150 Mils) – Tape and Reel	Industrial
CY2304SXC-2	8-pin SOIC (150 Mils)	Commercial
CY2304SXC-2T	8-pin SOIC (150 Mils) – Tape and Reel	Commercial
CY2304SXI-2	8-pin SOIC (150 Mils)	Industrial
CY2304SXI-2T	8-pin SOIC (150 Mils) – Tape and Reel	Industrial

Ordering Code Definitions

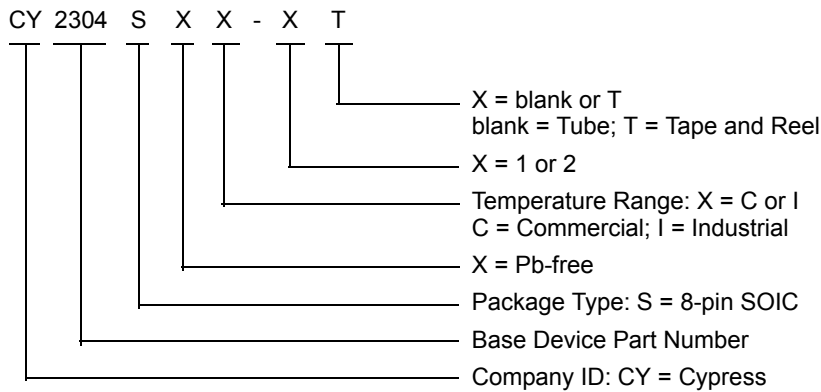

Package Diagram

Figure 9. 8-pin SOIC (150 Mils) Package Outline, 51-85066

1. DIMENSIONS IN INCHES[MM] MIN. MAX.
2. PIN 1 ID IS OPTIONAL, ROUND ON SINGLE LEADFRAME RECTANGULAR ON MATRIX LEADFRAME
3. REFERENCE JEDEC MS-012
4. PACKAGE WEIGHT 0.07gms

PART #	
S08.15	STANDARD PKG
SZ08.15	LEAD FREE PKG
SW8.15	LEAD FREE PKG

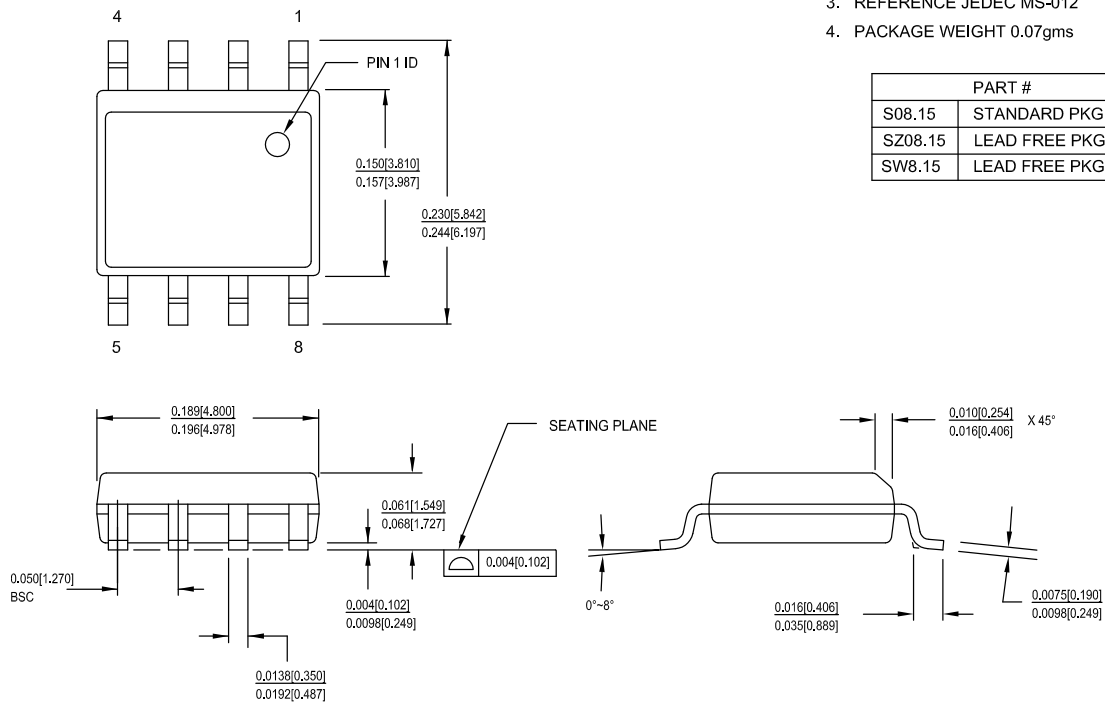

51-85066 *H

Acronyms

Acronym	Description
PLL	Phase Locked Loop
SOIC	Small Outline Integrated Circuit

Document Conventions

Units of Measure

Symbol	Units of Measure
°C	degree Celsius
MHz	megahertz
μA	microampere
mA	milliampere
ms	millisecond
ns	nanosecond
pF	picofarad
ps	picosecond
V	volt

Appendix: Silicon Errata for the Zero Delay Clock Buffers, CY2304

This section describes the errors, workaround solution and silicon design fixes for Cypress zero delay clock buffers belonging to the families CY2304. Details include errata trigger conditions, scope of impact, available workarounds, and silicon revision applicability. Contact your local Cypress Sales Representative if you have questions.

Part Numbers Affected

Table 1. Part Numbers Affected

Part Number	Device Variants
CY2304SXC-1	All Variants
CY2304SXC-1T	All Variants
CY2304SXC-2	All Variants
CY2304SXC-2T	All Variants
CY2304SXI-1	All Variants
CY2304SXI-1T	All Variants
CY2304SXI-2	All Variants
CY2304SXI-2T	All Variants

CY2304 Errata Summary

Items	Part Number	Fix Status
Start up lock time issue [CY2304]	All	Silicon fixed. New silicon available from WW 10 of 2013

CY2303 Qualification Status of fixed silicon

Product Status: In production

Qualification report last updated on 11/27/2012

<http://www.cypress.com/?rID=72595>

1. Start up lock time issue

■ Problem Definition

Output of CY2304 fails to locks within 1 ms upon power up (as per datasheet spec)

■ Parameters Affected

PLL lock time

■ Trigger Condition(s)

Start up

■ Scope of Impact

It can impact the performance of system and its throughput

■ Workaround

Apply reference input (RefClk) before power up (V_{DD}). If RefClk is applied after power up, noise gets coupled on the output and propagates back to the PLL causing it to take higher time to acquire lock. If reference input is present during power up, noise will not propagate to the PLL and device will start up normally without problems.

■ Fix Status

This issue is due to design marginality. Two minor design modifications have been made to address this problem.

- Addition of VCO bias detector block as shown in the following figure keeps comparator power down till VCO bias is present and thereby eliminating the propagation of noise to feedback.
- Bias generator enhancement for successful initialization.

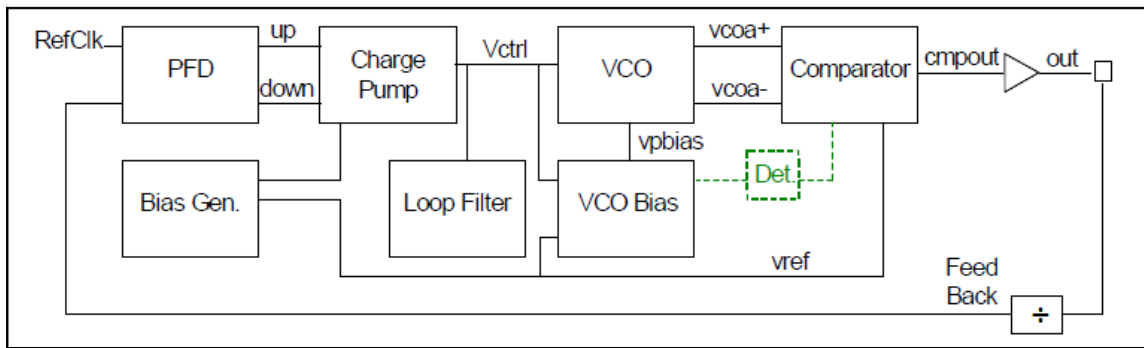

Document History Page

Document Title: CY2304, 3.3 V Zero Delay Buffer				
Document Number: 38-07247				
Rev.	ECN	Orig. of Change	Submission Date	Description of Change
**	110512	SZV	12/11/01	Change from Spec number: 38-01010 to 38-07247
*A	112294	CKN	03/04/02	On Pin Configuration Diagram (p.1), swapped CLKA2 and CLKA1
*B	113934	CKN	05/01/02	Added Operating Conditions for CY2304SI-X Industrial Temperature Devices, p. 4
*C	121851	RBI	12/14/02	Power up requirements added to Operating Conditions Information
*D	308436	RGL	01/26/05	Added Lead-free Devices
*E	2542331	AESA	09/18/08	Updated template. Added Note "Not recommended for new designs." Removed part number CY2304SI-2 and CY2304SI-2T. Changed Lead-Free to Pb-Free. Changed IDD (PD mode) from 12.0 to 25.0 μ A. Deleted Duty Cycle parameters for $F_{OUT} < 50.0$ MHz for commercial and industrial devices.
*F	2673353	KVM / PYRS	03/13/09	Reverted IDD (PD mode) and Duty Cycle parameters back to the values in revision *D: Changed IDD (PD mode) from 25 to 12 μ A for commercial devices. Added Duty Cycle parameters for $F_{OUT} < 50.0$ MHz for commercial and industrial devices.
*G	2906571	KVM	04/07/10	Removed parts CY2304SC-1, CY2304SC-1T, CY2304SC-2, CY2304SC-2T, CY2304SI-1, CY2304SI-1T from the ordering information table. Updated Package Diagram.
*H	3072674	BASH	10/27/2010	Corrected part number in all table titles (pages 3 to 5) from CY2304SC-X and CY2304SI-X to CY2304SXC and CY2304SXI. Removed "except t_8 " from Figure 7
*I	3162681	BASH	02/04/2011	Updated to new template.
*J	3204827	CXQ	03/24/2011	Added duty cycle spec for 83.0 MHz output condition.
*K	4018186	CINM	06/10/2013	Updated Package Diagram : spec 51-85066 – Changed revision from *D to *F. Added Appendix: Silicon Errata for the Zero Delay Clock Buffers, CY2304 .
*L	4291190	CINM	02/25/2014	Updated to new template. Completing Sunset Review.
*M	4578443	AJU	11/25/2014	Updated Functional Description : Added "For a complete list of related documentation, click here ." at the end.
*N	5270465	PSR	05/13/2016	Added Thermal Resistance . Updated Package Diagram : spec 51-85066 – Changed revision from *F to *H. Updated to new template.
*O	5663902	PAWK	03/17/2017	Updated to new template. Completing Sunset Review.

Sales, Solutions, and Legal Information

Worldwide Sales and Design Support

Cypress maintains a worldwide network of offices, solution centers, manufacturer's representatives, and distributors. To find the office closest to you, visit us at [Cypress Locations](#).

Products

ARM® Cortex® Microcontrollers	cypress.com/arm
Automotive	cypress.com/automotive
Clocks & Buffers	cypress.com/clocks
Interface	cypress.com/interface
Internet of Things	cypress.com/iot
Memory	cypress.com/memory
Microcontrollers	cypress.com/mcu
PSoC	cypress.com/psoc
Power Management ICs	cypress.com/pmic
Touch Sensing	cypress.com/touch
USB Controllers	cypress.com/usb
Wireless Connectivity	cypress.com/wireless

PSoC® Solutions

[PSoC 1](#) | [PSoC 3](#) | [PSoC 4](#) | [PSoC 5LP](#)

Cypress Developer Community

[Forums](#) | [WICED IOT Forums](#) | [Projects](#) | [Video](#) | [Blogs](#) | [Training](#) | [Components](#)

Technical Support

cypress.com/support



© Cypress Semiconductor Corporation, 2001-2017. This document is the property of Cypress Semiconductor Corporation and its subsidiaries, including Spansion LLC ("Cypress"). This document, including any software or firmware included or referenced in this document ("Software"), is owned by Cypress under the intellectual property laws and treaties of the United States and other countries worldwide. Cypress reserves all rights under such laws and treaties and does not, except as specifically stated in this paragraph, grant any license under its patents, copyrights, trademarks, or other intellectual property rights. If the Software is not accompanied by a license agreement and you do not otherwise have a written agreement with Cypress governing the use of the Software, then Cypress hereby grants you a personal, non-exclusive, nontransferable license (without the right to sublicense) (1) under its copyright rights in the Software (a) for Software provided in source code form, to modify and reproduce the Software solely for use with Cypress hardware products, only internally within your organization, and (b) to distribute the Software in binary code form externally to end users (either directly or indirectly through resellers and distributors), solely for use on Cypress hardware product units, and (2) under those claims of Cypress's patents that are infringed by the Software (as provided by Cypress, unmodified) to make, use, distribute, and import the Software solely for use with Cypress hardware products. Any other use, reproduction, modification, translation, or compilation of the Software is prohibited.

TO THE EXTENT PERMITTED BY APPLICABLE LAW, CYPRESS MAKES NO WARRANTY OF ANY KIND, EXPRESS OR IMPLIED, WITH REGARD TO THIS DOCUMENT OR ANY SOFTWARE OR ACCOMPANYING HARDWARE, INCLUDING, BUT NOT LIMITED TO, THE IMPLIED WARRANTIES OF MERCHANTABILITY AND FITNESS FOR A PARTICULAR PURPOSE. To the extent permitted by applicable law, Cypress reserves the right to make changes to this document without further notice. Cypress does not assume any liability arising out of the application or use of any product or circuit described in this document. Any information provided in this document, including any sample design information or programming code, is provided only for reference purposes. It is the responsibility of the user of this document to properly design, program, and test the functionality and safety of any application made of this information and any resulting product. Cypress products are not designed, intended, or authorized for use as critical components in systems designed or intended for the operation of weapons, weapons systems, nuclear installations, life-support devices or systems, other medical devices or systems (including resuscitation equipment and surgical implants), pollution control or hazardous substances management, or other uses where the failure of the device or system could cause personal injury, death, or property damage ("Unintended Uses"). A critical component is any component of a device or system whose failure to perform can be reasonably expected to cause the failure of the device or system, or to affect its safety or effectiveness. Cypress is not liable, in whole or in part, and you shall and hereby do release Cypress from any claim, damage, or other liability arising from or related to all Unintended Uses of Cypress products. You shall indemnify and hold Cypress harmless from and against all claims, costs, damages, and other liabilities, including claims for personal injury or death, arising from or related to any Unintended Uses of Cypress products.

Cypress, the Cypress logo, Spansion, the Spansion logo, and combinations thereof, PSoC, CapSense, EZ-USB, F-RAM, and Traveo are trademarks or registered trademarks of Cypress in the United States and other countries. For a more complete list of Cypress trademarks, visit cypress.com. Other names and brands may be claimed as property of their respective owners.

Looking for pricing, stock, or lifecycle information?

Click below to explore more details on WIN SOURCE:

-  [View CY2304SXI-2 on WIN SOURCE](#)
-  [Cypress Semiconductor Corp](#) Information

Optimize Your Supply Chain with WIN SOURCE Solutions

-  Global Sourcing Solution
-  Obsolete Management
-  Cost Control Management
-  Shortage Management
-  Alternative Solution
-  Excess Inventory Management