



**THE DATASHEET OF
CY2305CSXC-1T**



3.3 V Zero Delay Clock Buffer

Features

- 10 MHz to 100–133 MHz operating range
- Zero input and output propagation delay
- Multiple low skew outputs
- One input drives five outputs (CY2305C)
- One input drives nine outputs, grouped as 4 + 4 + 1 (CY2309C)
- 50 ps typical cycle-to-cycle jitter (15 pF, 66 MHz)
- Test mode to bypass phase locked loop (PLL) (CY2309C) only, see [Select Input Decoding on page 6](#)
- Available in space saving 16-pin 150 Mil small outline integrated circuit (SOIC) or 4.4 mm thin shrunk small outline package (TSSOP) packages (CY2309C), and 8-pin, 150 Mil SOIC package (CY2305C)
- 3.3 V operation
- Commercial, industrial and automotive-A flows available

Functional Description

The CY2305C and CY2309C are die replacement parts for CY2305 and CY2309.

The CY2309C is a low-cost 3.3 V zero delay buffer designed to distribute high speed clocks and is available in a 16-pin SOIC or TSSOP package. The CY2305C is an 8-pin version of the CY2309C. It accepts one reference input and drives out five low skew clocks. The -1H versions of each device operate up to

100 MHz–133 MHz frequencies and have higher drive than the -1 devices. All parts have on-chip phase locked loops (PLLs) which lock to an input clock on the REF pin. The PLL feedback is on-chip and is obtained from the CLKOUT pad.

The CY2309C has two banks of four outputs each that are controlled by the select inputs as shown in the [Select Input Decoding on page 6](#). If all output clocks are not required, Bank B is three-stated. The input clock is directly applied to the outputs by the select inputs for chip and system testing purposes.

The CY2305C and CY2309C PLLs enter a power down mode when there are no rising edges on the REF input. In this state, the outputs are three-stated and the PLL is turned off. This results in less than 12.0 μ A of current draw for commercial temperature devices and 25.0 μ A for industrial and automotive-A temperature parts. The CY2309C PLL shuts down in one additional case as shown in the [Select Input Decoding on page 6](#).

In the special case when S2:S1 is 1:0, the PLL is bypassed and REF is output from DC to the maximum allowable frequency. The part behaves as a non-zero delay buffer in this mode and the outputs are not three-stated.

The CY2305C or CY2309C is available in two or three different configurations as shown in the [Ordering Information on page 15](#). The CY2305C-1 or CY2309C-1 is the base part. The CY2305-1H or CY2309-1H is the high drive version of the -1. Its rise and fall times are much faster than the -1.

For a complete list of related documentation, click [here](#).

Logic Block Diagram – CY2305C

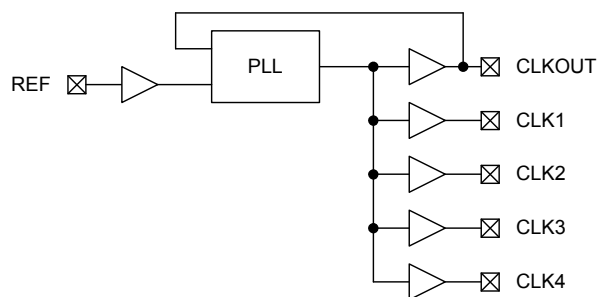

Logic Block Diagram – CY2309C

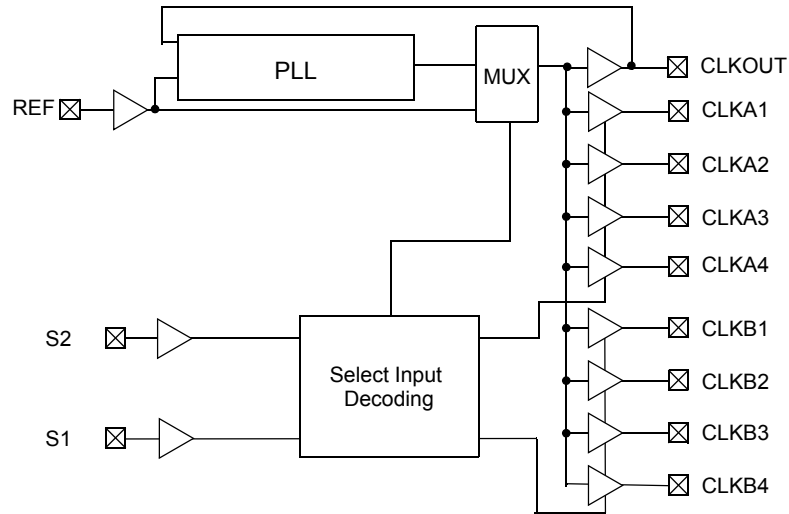

Contents

Pinouts	4	Switching Waveforms	14
Pin Definitions	5	Ordering Information	15
Pin Definitions	5	Ordering Code Definitions	16
Functional Overview	6	Package Diagrams	17
Select Input Decoding	6	Acronyms	19
Zero Delay and Skew Control	6	Document Conventions	19
Absolute Maximum Conditions	7	Units of Measure	19
Operating Conditions	7	Document History Page	20
Operating Conditions	7	Sales, Solutions, and Legal Information	22
Electrical Characteristics	8	Worldwide Sales and Design Support	22
Electrical Characteristics	8	Products	22
Test Circuits	9	PSoC@Solutions	22
Thermal Resistance	9	Cypress Developer Community	22
Switching Characteristics	10	Technical Support	22
Switching Characteristics	11		
Switching Characteristics	12		
Switching characteristics	13		

Pinouts

**Figure 1. 8-pin SOIC pinout (Top View)
CY2305C**

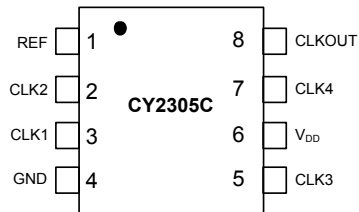

**Figure 2. 16-pin SOIC / TSSOP pinout (Top View)
CY2309C**

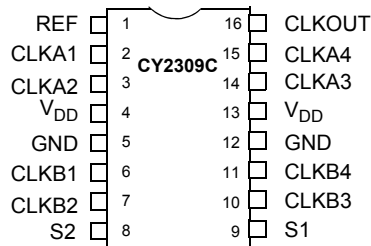

Pin Definitions

8-pin SOIC

Pin	Signal	Description
1	REF ^[1]	Input reference frequency
2	CLK2 ^[2]	Buffered clock output
3	CLK1 ^[2]	Buffered clock output
4	GND	Ground
5	CLK3 ^[2]	Buffered clock output
6	V _{DD}	3.3 V supply
7	CLK4 ^[2]	Buffered clock output
8	CLKOUT ^[2]	Buffered clock output, internal feedback on this pin

Pin Definitions

16-pin SOIC / TSSOP

Pin	Signal	Description
1	REF ^[1]	Input reference frequency
2	CLKA1 ^[2]	Buffered clock output, Bank A
3	CLKA2 ^[2]	Buffered clock output, Bank A
4	V _{DD}	3.3 V supply
5	GND	Ground
6	CLKB1 ^[2]	Buffered clock output, Bank B
7	CLKB2 ^[2]	Buffered clock output, Bank B
8	S2 ^[3]	Select input, bit 2
9	S1 ^[3]	Select input, bit 1
10	CLKB3 ^[2]	Buffered clock output, Bank B
11	CLKB4 ^[2]	Buffered clock output, Bank B
12	GND	Ground
13	V _{DD}	3.3 V supply
14	CLKA3 ^[2]	Buffered clock output, Bank A
15	CLKA4 ^[2]	Buffered clock output, Bank A
16	CLKOUT ^[2]	Buffered output, internal feedback on this pin

Notes

1. Weak pull down.
2. Weak pull down on all outputs.
3. Weak pull ups on these inputs.

Functional Overview

Select Input Decoding

For CY2309C

S2	S1	CLOCK A1–A4	CLOCK B1–B4	CLKOUT ^[4]	Output Source	PLL Shutdown
0	0	Three state	Three state	Driven	PLL	N
0	1	Driven	Three state	Driven	PLL	N
1	0	Driven	Driven	Driven	Reference	Y
1	1	Driven	Driven	Driven	PLL	N

Figure 3. REF. Input to CLKA/CLKB Delay vs. Loading Difference between CLKOUT and CLKA/CLKB pins

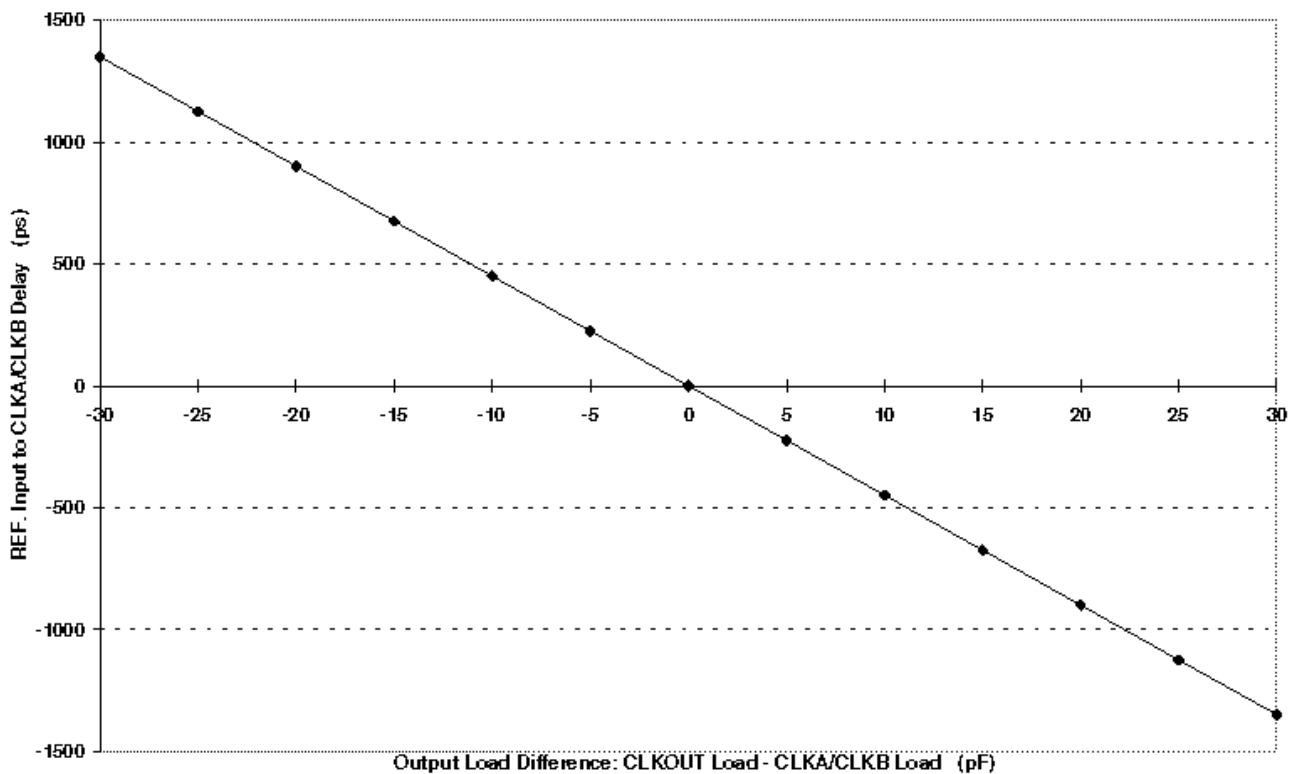

Zero Delay and Skew Control

All outputs must be uniformly loaded to achieve Zero Delay between the input and output. Since the CLKOUT pin is the internal feedback to the PLL, its relative loading can adjust the input or output delay.

For applications requiring zero input or output delay, all outputs including CLKOUT are equally loaded. Even if CLKOUT is not used, it must have a capacitive load equal to that on other outputs for obtaining zero input or output delay.

For zero output to output skew, all outputs must be loaded equally.

Even if CLKOUT is not used, it must have a capacitive load, equal to that on other outputs, for obtaining zero input-output delay. If input to output delay adjustments are required, use Figure 3 to calculate loading differences between the CLKOUT pin and other outputs.

Note

- This output is driven and has an internal feedback for the PLL. The load on this output is adjusted to change the skew between the reference and output.

Absolute Maximum Conditions

Supply voltage to ground potential -0.5 V to +4.6 V
 DC input voltage (Except REF) -0.5 V to $V_{DD} + 0.5$ V
 DC input voltage REF -0.5 V to $V_{DD} + 0.5$ V

Storage temperature -65 °C to +150 °C
 Junction temperature 150 °C
 Static discharge voltage
 (per MIL-STD-883, Method 3015) > 2,000 V

Operating Conditions

Operating Conditions Table for CY2305CSXC-XX and CY2309CSXC-XX Commercial Temperature devices.

Parameter	Description	Min	Max	Unit
V_{DD}	Supply voltage	3.0	3.6	V
T_A	Operating temperature (ambient temperature)	0	70	°C
C_L	Load capacitance, below 100 MHz	–	30	pF
C_L	Load capacitance, from 100 MHz to 133 MHz	–	10	pF
C_{IN}	Input capacitance	–	7	pF
t_{PU}	Power-up time for all V_{DD} s to reach minimum specified voltage (power ramps are monotonic)	0.05	50	ms

Operating Conditions

Operating Conditions Table for CY2305CSXI-XX, CY2305CSXA-XX and CY2309CSXI-XX Industrial / Automotive-A Temperature devices.

Parameter	Description	Min	Max	Unit
V_{DD}	Supply voltage	3.0	3.6	V
T_A	Operating temperature (ambient temperature)	-40	85	°C
C_L	Load capacitance, below 100 MHz	–	30	pF
C_L	Load capacitance, from 100 MHz to 133 MHz	–	10	pF
C_{IN}	Input capacitance	–	7	pF
t_{PU}	Power-up time for all V_{DD} s to reach minimum specified voltage (power ramps are monotonic)	0.05	50	ms

Electrical Characteristics

Electrical Characteristics Table for CY2305CSXC-XX and CY2309CSXC-XX Commercial Temperature devices.

Parameter	Description	Test Conditions	Min	Max	Unit
V_{IL}	Input LOW voltage ^[5]		–	0.8	V
V_{IH}	Input HIGH voltage ^[5]		2.0	–	V
I_{IL}	Input LOW current	$V_{IN} = 0\text{ V}$	–	50	μA
I_{IH}	Input HIGH current	$V_{IN} = V_{DD}$	–	100	μA
V_{OL}	Output LOW voltage ^[6]	$I_{OL} = 8\text{ mA} (-1)$	–	0.4	V
		$I_{OL} = 12\text{ mA} (-1H)$			
V_{OH}	Output HIGH voltage ^[6]	$I_{OH} = -8\text{ mA} (-1)$	2.4	–	V
		$I_{OH} = -12\text{ mA} (-1H)$			
I_{DD} (PD mode)	Power-down supply current	REF = 0 MHz	–	12	μA
I_{DD}	Supply current	Unloaded outputs at 66.67 MHz, SEL inputs at V_{DD}	–	32	mA

Electrical Characteristics

Electrical Characteristics Table for CY2305CSXI-XX, CY2305CSXA-XX and CY2309CSXI-XX Industrial / Automotive-A Temperature devices.

Parameter	Description	Test Conditions	Min	Max	Unit
V_{IL}	Input LOW voltage ^[5]		–	0.8	V
V_{IH}	Input HIGH voltage ^[5]		2.0	–	V
I_{IL}	Input LOW current	$V_{IN} = 0\text{ V}$	–	50	μA
I_{IH}	Input HIGH current	$V_{IN} = V_{DD}$	–	100	μA
V_{OL}	Output LOW voltage ^[6]	$I_{OL} = 8\text{ mA} (-1)$	–	0.4	V
		$I_{OL} = 12\text{ mA} (-1H)$			
V_{OH}	Output HIGH voltage ^[6]	$I_{OH} = -8\text{ mA} (-1)$	2.4	–	V
		$I_{OH} = -12\text{ mA} (-1H)$			
I_{DD} (PD mode)	Power-down supply current	REF = 0 MHz	–	25	μA
I_{DD}	Supply current	Unloaded outputs at 66.67 MHz, SEL inputs at V_{DD}	–	35	mA

Notes

- REF input has a threshold voltage of $V_{DD}/2$.
- Parameter is guaranteed by design and characterization. Not 100% tested in production.

Test Circuits

Figure 4. Test Circuits

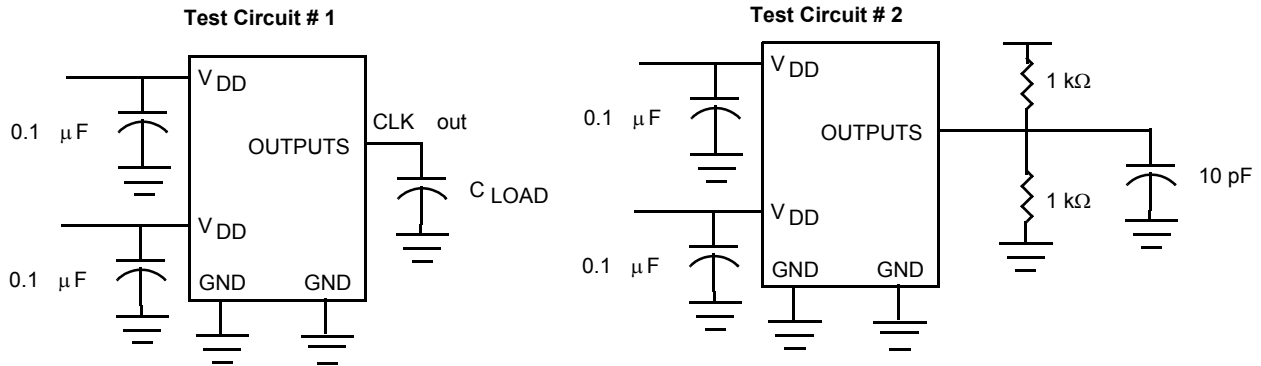

For parameter t_g (output slew rate) on -1H devices

Thermal Resistance

Parameter ^[7]	Description	Test Conditions	8-pin SOIC	16-pin SOIC	16-pin TSSOP	Unit
θ_{JA}	Thermal resistance (junction to ambient)	Test conditions follow standard test methods and procedures for measuring thermal impedance, in accordance with EIA/JESD51.	145	121	111	°C/W
θ_{JC}	Thermal resistance (junction to case)		62	53	26	°C/W

Note

7. These parameters are guaranteed by design and are not tested.

Switching Characteristics

Switching Characteristics Table for CY2305CSXC-1 and CY2309CSXC-1 Commercial Temperature devices. All parameters are specified with loaded outputs.

Parameter	Description	Test Conditions	Min	Typ	Max	Unit
t ₁	Output frequency	30 pF load	10	–	100	MHz
		10 pF load	10	–	133.33	MHz
t _{DC}	Output duty cycle ^[8] = t ₂ ÷ t ₁	Measured at 1.4 V, F _{out} > 50 MHz	40	50	60	%
		Measured at 1.4 V, F _{out} ≤ 50 MHz	45	50	55	%
t ₃	Rise time ^[8]	Measured between 0.8 V and 2.0 V	–	–	2.25	ns
t ₄	Fall time ^[8]	Measured between 0.8 V and 2.0 V	–	–	2.25	ns
t ₅	Output-to-output skew ^[8]	All outputs equally loaded	–	–	200	ps
t _{6A}	Delay, REF rising edge to CLKOUT rising edge ^[8]	Measured at V _{DD} /2	–	0	±350	ps
t _{6B}	Delay, REF rising edge to CLKOUT rising edge ^[8]	Measured at V _{DD} /2. Measured in PLL Bypass mode, CY2309C device only.	1	5	8.7	ns
t ₇	Device-to-device skew ^[8]	Measured at V _{DD} /2 on the CLKOUT pins of devices	–	0	700	ps
t _J	Cycle-to-cycle jitter, peak ^[8]	Measured at 66.67 MHz, loaded outputs	–	50	175	ps
t _{LOCK}	PLL lock time ^[8]	Stable power supply, valid clock presented on REF pin	–	–	1.0	ms

Note

8. Parameter is guaranteed by design and characterization. Not 100% tested in production.

Switching Characteristics

Switching Characteristics Table for CY2305CSXC-1H and CY2309CSXC-1H Commercial Temperature devices. All parameters are specified with loaded outputs.

Parameter	Description	Description	Min	Typ	Max	Unit
t ₁	Output frequency	30 pF load	10	–	100	MHz
		10 pF load	10	–	133.33	MHz
t _{DC}	Output duty cycle ^[9] = t ₂ ÷ t ₁	Measured at 1.4 V, F _{out} > 50 MHz	40	50	60	%
		Measured at 1.4 V, F _{out} ≤ 50 MHz	45	50	55	%
t ₃	Rise time ^[9]	Measured between 0.8 V and 2.0 V	–	–	1.5	ns
t ₄	Fall time ^[9]	Measured between 0.8 V and 2.0 V	–	–	1.5	ns
t ₅	Output-to-output skew ^[9]	All outputs equally loaded	–	–	200	ps
t _{6A}	Delay, REF rising edge to CLKOUT rising edge ^[9]	Measured at V _{DD} /2	–	0	±350	ps
t _{6B}	Delay, REF rising edge to CLKOUT rising edge ^[9]	Measured at V _{DD} /2. Measured in PLL Bypass mode, CY2309C device only.	1	5	8.7	ns
t ₇	Device-to-device skew ^[9]	Measured at V _{DD} /2 on the CLKOUT pins of devices	–	0	700	ps
t ₈	Output slew rate ^[9]	Measured between 0.8 V and 2.0 V using Test circuit #2	1	–	–	V/ns
t _J	Cycle-to-cycle jitter, peak ^[9]	Measured at 66.67 MHz, loaded outputs	–	–	175	ps
t _{LOCK}	PLL lock time ^[9]	Stable power supply, valid clock presented on REF pin	–	–	1.0	ms

Note

9. Parameter is guaranteed by design and characterization. Not 100% tested in production.

Switching Characteristics

Switching Characteristics Table for CY2305CSXI-1, CY2305CSXA-1, and CY2309CSXI-1 Industrial Temperature devices. All parameters are specified with loaded outputs.

Parameter	Description	Test Conditions	Min	Typ	Max	Unit
t ₁	Output frequency	30 pF load	10	–	100	MHz
		10 pF load	10	–	133.33	MHz
t _{DC}	Output duty cycle ^[10] = t ₂ ÷ t ₁	Measured at 1.4 V, F _{out} > 50 MHz	40	50	60	%
		Measured at 1.4 V, F _{out} ≤ 50 MHz	45	50	55	%
t ₃	Rise time ^[10]	Measured between 0.8 V and 2.0 V	–	–	2.25	ns
t ₄	Fall time ^[10]	Measured between 0.8 V and 2.0 V	–	–	2.25	ns
t ₅	Output-to-output skew ^[10]	All outputs equally loaded	–	–	200	ps
t _{6A}	Delay, REF rising edge to CLKOUT rising edge ^[10]	Measured at V _{DD} /2	–	0	±350	ps
t _{6B}	Delay, REF rising edge to CLKOUT rising edge ^[10]	Measured at V _{DD} /2. Measured in PLL Bypass mode, CY2309C device only.	1	5	8.7	ns
t ₇	Device-to-device skew ^[10]	Measured at V _{DD} /2 on the CLKOUT pins of devices	–	0	700	ps
t _J	Cycle-to-cycle jitter, peak ^[10]	Measured at 66.67 MHz, loaded outputs	–	50	175	ps
t _{LOCK}	PLL lock time ^[10]	Stable power supply, valid clock presented on REF pin	–	–	1.0	ms

Note

10. Parameter is guaranteed by design and characterization. Not 100% tested in production.

Switching characteristics

Switching Characteristics Table for CY2305CSXI-1H, CY2305CSXA-1H and CY2309CSXI-1H Industrial / Automotive-A Temperature devices. All parameters are specified with loaded outputs.

Parameter	Description	Description	Min	Typ	Max	Unit
t ₁	Output frequency	30 pF load	10	–	100	MHz
		10 pF load	10	–	133.33	MHz
t _{DC}	Output duty cycle ^[11] = t ₂ ÷ t ₁	Measured at 1.4 V, F _{out} > 50 MHz	40	50	60	%
		Measured at 1.4 V, F _{out} ≤ 50 MHz	45	50	55	%
t ₃	Rise time ^[11]	Measured between 0.8 V and 2.0 V	–	–	1.5	ns
t ₄	Fall time ^[11]	Measured between 0.8 V and 2.0 V	–	–	1.5	ns
t ₅	Output-to-output skew ^[11]	All outputs equally loaded	–	–	200	ps
t _{6A}	Delay, REF rising edge to CLKOUT rising edge ^[11]	Measured at V _{DD} /2	–	0	±350	ps
t _{6B}	Delay, REF rising edge to CLKOUT rising edge ^[11]	Measured at V _{DD} /2. Measured in PLL Bypass mode, CY2309C device only.	1	5	8.7	ns
t ₇	Device-to-device skew ^[11]	Measured at V _{DD} /2 on the CLKOUT pins of devices	–	0	700	ps
t ₈	Output slew rate ^[11]	Measured between 0.8 V and 2.0 V using Test circuit #2	1	–	–	V/ns
t _J	Cycle-to-cycle jitter, peak ^[11]	Measured at 66.67 MHz, loaded outputs	–	–	175	ps
t _{LOCK}	PLL lock time ^[11]	Stable power supply, valid clock presented on REF pin	–	–	1.0	ms

Note

11. Parameter is guaranteed by design and characterization. Not 100% tested in production.

Switching Waveforms

Figure 5. Duty Cycle Timing

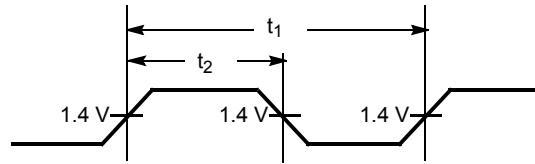

Figure 6. All Outputs Rise/Fall Time

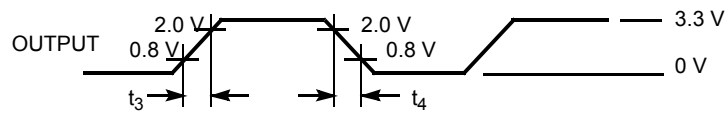

Figure 7. Output-Output Skew

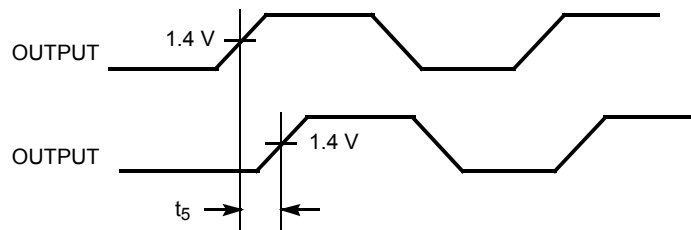

Figure 8. Input-Output Propagation Delay

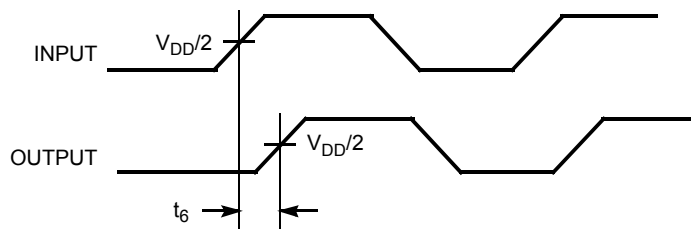
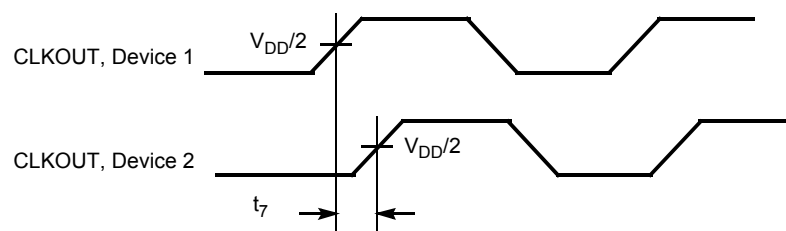

Figure 9. Device-Device Skew



Ordering Information

Ordering Code	Package Type	Operating Range
Pb-free - CY2305C		
CY2305CSXC-1	8-pin SOIC (150 Mil)	Commercial
CY2305CSXC-1T	8-pin SOIC (150 Mil) – Tape and Reel	Commercial
CY2305CSXC-1H	8-pin SOIC (150 Mil)	Commercial
CY2305CSXC-1HT	8-pin SOIC (150 Mil) – Tape and Reel	Commercial
CY2305CSXI-1	8-pin SOIC (150 Mil)	Industrial
CY2305CSXI-1T	8-pin SOIC (150 Mil) – Tape and Reel	Industrial
CY2305CSXI-1H	8-pin SOIC (150 Mil)	Industrial
CY2305CSXI-1HT	8-pin SOIC (150 Mil) – Tape and Reel	Industrial
CY2305CSXA-1H	8-pin SOIC (150 Mil)	Automotive-A
CY2305CSXA-1HT	8-pin SOIC (150 Mil) – Tape and Reel	Automotive-A
Pb-free - CY2309C		
CY2309CSXC-1	16-pin SOIC (150 Mil)	Commercial
CY2309CSXC-1T	16-pin SOIC (150 Mil) – Tape and Reel	Commercial
CY2309CSXC-1H	16-pin SOIC (150 Mil)	Commercial
CY2309CSXC-1HT	16-pin SOIC (150 Mil) – Tape and Reel	Commercial
CY2309CSXI-1	16-pin SOIC (150 Mil)	Industrial
CY2309CSXI-1T	16-pin SOIC (150 Mil) – Tape and Reel	Industrial
CY2309CSXI-1H	16-pin SOIC (150 Mil)	Industrial
CY2309CSXI-1HT	16-pin SOIC (150 Mil) – Tape and Reel	Industrial
CY2309CZXC-1	16-pin TSSOP (4.4 mm)	Commercial
CY2309CZXC-1T	16-pin TSSOP (4.4 mm) – Tape and Reel	Commercial
CY2309CZXC-1H	16-pin TSSOP (4.4 mm)	Commercial
CY2309CZXC-1HT	16-pin TSSOP (4.4 mm) – Tape and Reel	Commercial
CY2309CZXI-1	16-pin TSSOP (4.4 mm)	Industrial
CY2309CZXI-1T	16-pin TSSOP (4.4 mm) – Tape and Reel	Industrial
CY2309CZXI-1H	16-pin TSSOP (4.4 mm)	Industrial
CY2309CZXI-1HT	16-pin TSSOP (4.4 mm) – Tape and Reel	Industrial

Ordering Code Definitions

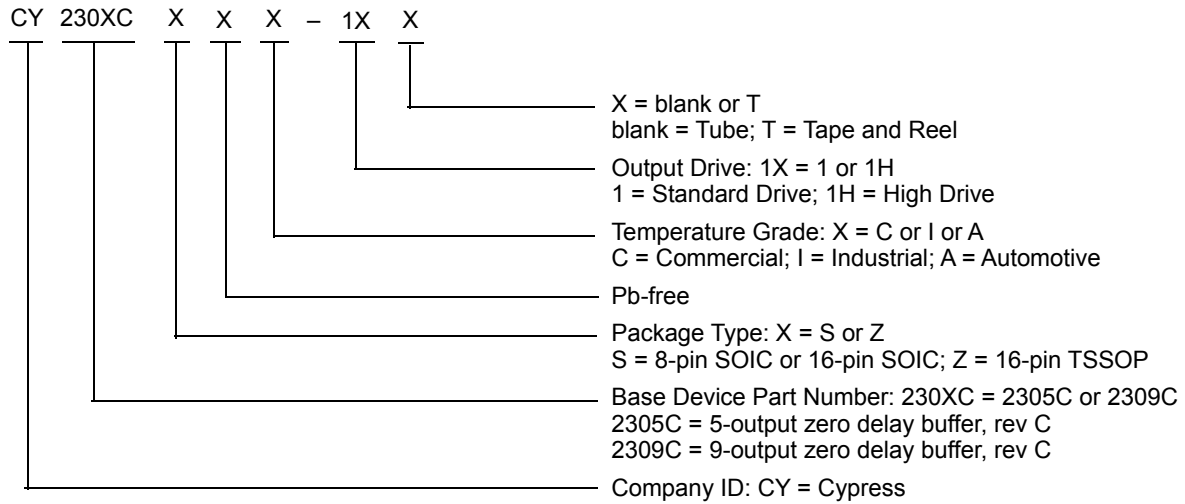

Package Diagrams

Figure 10. 8-pin SOIC (150 Mils) S0815/SZ815/SW815 Package Outline, 51-85066

1. DIMENSIONS IN INCHES[MM] MIN.
MAX.
2. PIN 1 ID IS OPTIONAL,
ROUND ON SINGLE LEADFRAME
RECTANGULAR ON MATRIX LEADFRAME
3. REFERENCE JEDEC MS-012
4. PACKAGE WEIGHT 0.07gms

PART #	
S08.15	STANDARD PKG
SZ08.15	LEAD FREE PKG
SW8.15	LEAD FREE PKG

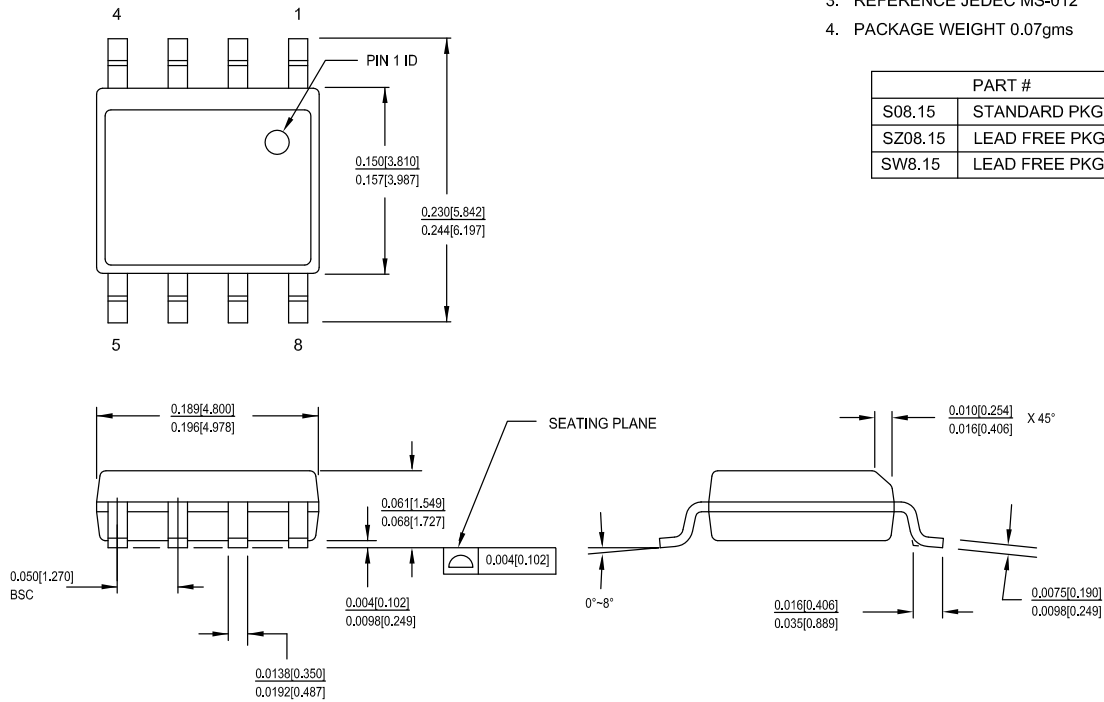

51-85066 *H

Package Diagrams (continued)

Figure 11. 16-pin SOIC (150 Mil) S16.15/SZ16.15 Package Outline, 51-85068

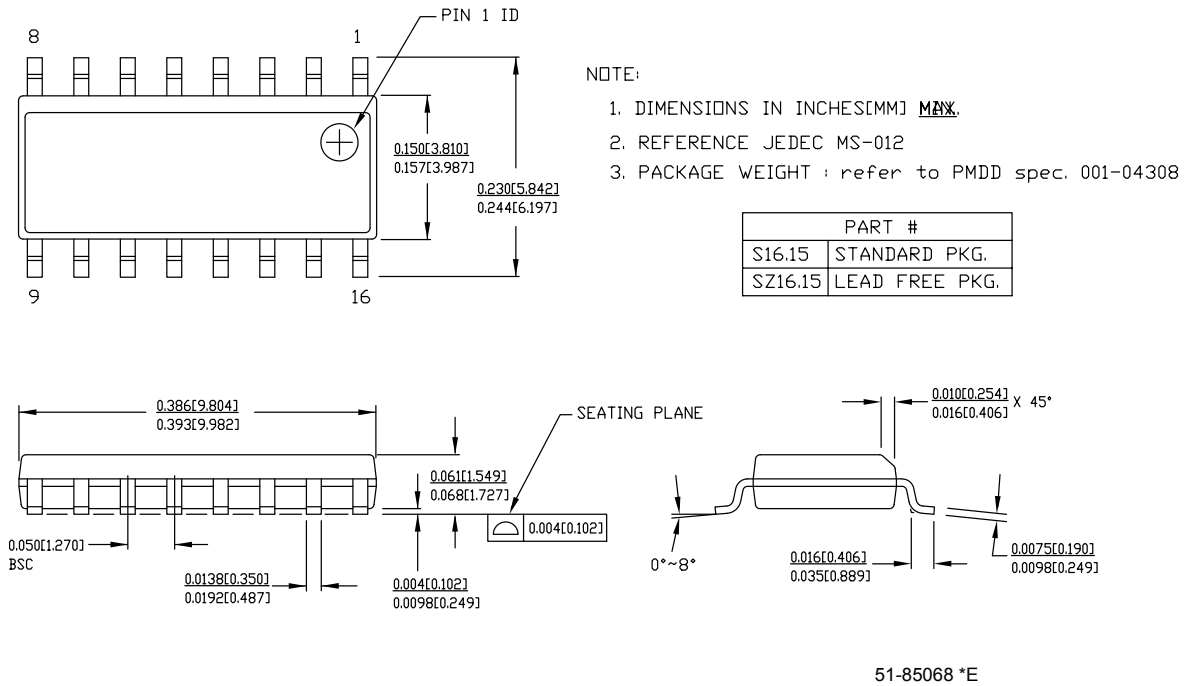
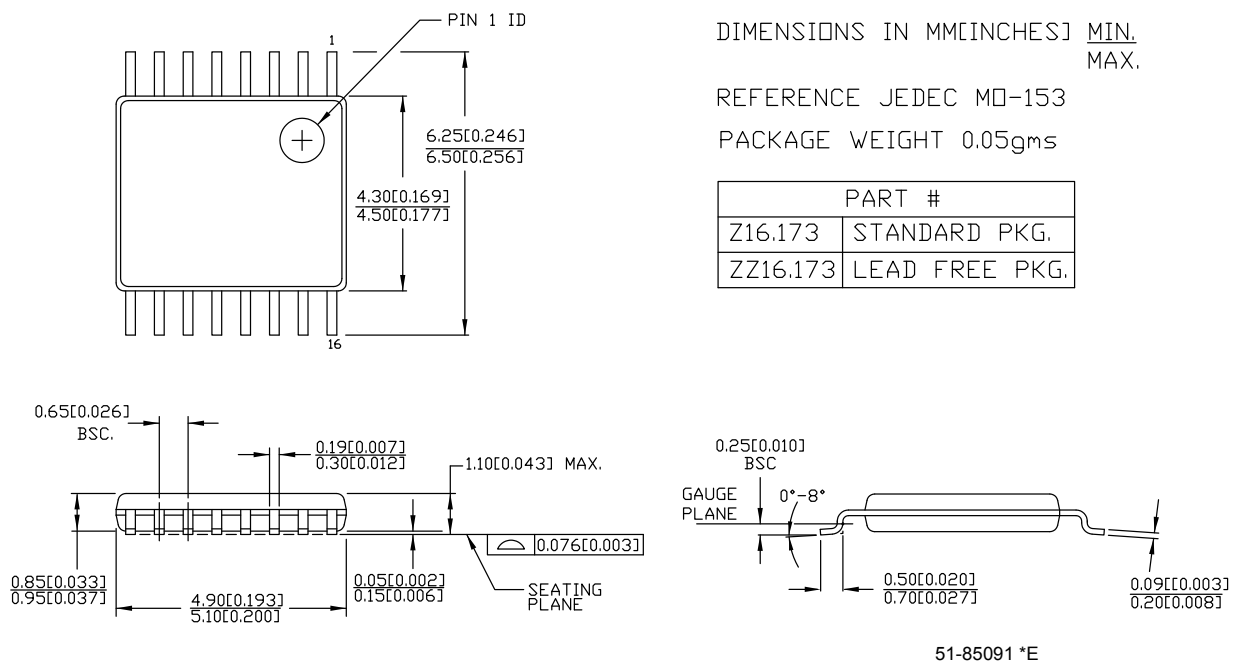

Figure 12. 16-pin TSSOP (4.40 mm Body) Z16.173/ZZ16.173 Package Outline, 51-85091



Acronyms

Acronym	Description
CMOS	Complementary Metal Oxide Semiconductor
PLL	Phase Locked Loop
SOIC	Small Outline Integrated Circuit
TSSOP	Thin Shrunk Small Outline Package

Document Conventions

Units of Measure

Symbol	Unit of Measure
°C	degree Celsius
kHz	kilohertz
MHz	megahertz
μA	microampere
mA	milliampere
ms	millisecond
ns	nanosecond
pF	picofarad
ps	picosecond
V	volt

Document History Page

Document Title: CY2305C/CY2309C, 3.3 V Zero Delay Clock Buffer Document Number: 38-07672				
Rev.	ECN No.	Issue Date	Orig. of Change	Description of Change
**	224421	See ECN	RGL	New data sheet
*A	268571	See ECN	RGL	Added bullet for 5 V tolerant inputs in the features
*B	276453	See ECN	RGL	Minor Change: Moved one sentence from the features to the Functional Description
*C	303063	See ECN	RGL	Updated data sheet as per characterization data
*D	318315	See ECN	RGL	Data sheet rewrite
*E	344815	See ECN	RGL	Minor Error: Corrected the header of all the AC/DC tables with the right part numbers.
*F	1279889	See ECN	KVM	<p>Changed title from "CY2305C/CY2309C, Low Cost 3.3 V Zero Delay Buffer" to "CY2305C/CY2309C, 3.3 V Zero Delay Clock Buffer".</p> <p>Specified the VIL minimum value to -0.3 V</p> <p>Specified the VIH maximum value to VDD + 0.3 V</p> <p>Changed DC Input Voltage (REF) maximum value in Absolute Maximum section</p> <p>Removed references to 5 V tolerant inputs (pages 1 and 2)</p> <p>Removed Pentium compatibility reference</p> <p>Added CY2305C block diagram</p> <p>Added σ_{peak} to the jitter specifications</p> <p>Changed typical jitter from 75 ps to 50 ps for standard drive devices</p> <p>For standard drive devices, tightened rise/fall times from 2.5 ns to 2.25 ns</p> <p>Tightened cycle-to-cycle jitter from 200 ps to 175 ps</p> <p>Tightened output-to-output skew from 250 ps to 200 ps</p>
*G	1561504	See ECN	KVM / NSI / AESA	<p>Changed status from Preliminary to Final.</p> <p>Added CY2305C Automotive-A grade devices</p> <p>Extended duty cycle specs to cover entire frequency range</p>
*H	2558537	08/27/08	KVM / AESA	<p>Updated Ordering Information:</p> <p>Added CY2305CSXA-1 and CY2305CSXA-1T parts under Pb-free CY2305C.</p>
*I	2901743	03/30/2010	VIVG	<p>Added Ordering Code Definitions under Ordering Information.</p> <p>Updated Package Diagrams.</p>
*J	3080990	11/10/2010	BASH	<p>Updated Pinouts:</p> <p>Updated Figure 1 (Modified pin diagram).</p> <p>Added Acronyms and Units of Measure.</p> <p>Updated to new template.</p>
*K	3160535	02/03/2011	BASH	<p>Updated Electrical Characteristics:</p> <p>Removed minimum value of V_{IL} parameter and maximum value of V_{IH} parameter.</p> <p>Updated Electrical Characteristics:</p> <p>Removed minimum value of V_{IL} parameter and maximum value of V_{IH} parameter.</p> <p>Updated Ordering Information:</p> <p>Removed Prune parts CY2305CSXA-1 and CY2305CSXA-1T.</p>
*L	3822852	11/27/2012	PURU	<p>Updated Functional Overview:</p> <p>Updated Select Input Decoding (Added Figure 3 only, no edits).</p> <p>Updated Zero Delay and Skew Control (Minor edits).</p> <p>Updated Package Diagrams:</p> <p>spec 51-85091 – Changed revision from *C to *D.</p> <p>spec 51-85068 – Changed revision from *C to *E.</p> <p>spec 51-85066 – Changed revision from *D to *E.</p>

Document History Page *(continued)*

Document Title: CY2305C/CY2309C, 3.3 V Zero Delay Clock Buffer				
Document Number: 38-07672				
Rev.	ECN No.	Issue Date	Orig. of Change	Description of Change
*M	4201564	11/25/2013	CINM	Updated Package Diagrams : spec 51-85066 – Changed revision from *E to *F. Updated to new template. Completing Sunset Review.
*N	4578443	11/25/2014	TAVA	Updated Functional Description : Added “For a complete list of related documentation, click here .” at the end. Updated Package Diagrams .
*O	5242528	04/15/2016	SDHK / PSR	Updated Electrical Characteristics : Updated details in “Test Conditions” column corresponding to V_{OL} and V_{OH} parameters. Updated Electrical Characteristics : Updated details in “Test Conditions” column corresponding to V_{OL} and V_{OH} parameters. Added Thermal Resistance . Updated Package Diagrams : spec 51-85066 – Changed revision from *F to *H. Updated to new template.
*P	5553658	12/14/2016	TAVA	Updated to new template. Completing Sunset Review.
*Q	5708829	04/27/2017	AESATMP7	Updated Cypress Logo and Copyright.

Sales, Solutions, and Legal Information

Worldwide Sales and Design Support

Cypress maintains a worldwide network of offices, solution centers, manufacturer's representatives, and distributors. To find the office closest to you, visit us at [Cypress Locations](#).

Products

ARM® Cortex® Microcontrollers	cypress.com/arm
Automotive	cypress.com/automotive
Clocks & Buffers	cypress.com/clocks
Interface	cypress.com/interface
Internet of Things	cypress.com/iot
Lighting & Power Control	cypress.com/powerpsoc
Memory	cypress.com/memory
PSoC	cypress.com/psoc
Touch Sensing	cypress.com/touch
USB Controllers	cypress.com/usb
Wireless/RF	cypress.com/wireless

PSoC® Solutions

[PSoC 1](#) | [PSoC 3](#) | [PSoC 4](#) | [PSoC 5LP](#) | [PSoC 6](#)

Cypress Developer Community

[Forums](#) | [WICED IoT Forums](#) | [Projects](#) | [Video](#) | [Blogs](#) | [Training](#) | [Components](#)

Technical Support

cypress.com/support



© Cypress Semiconductor Corporation, 2004-2017. This document is the property of Cypress Semiconductor Corporation and its subsidiaries, including Spansion LLC ("Cypress"). This document, including any software or firmware included or referenced in this document ("Software"), is owned by Cypress under the intellectual property laws and treaties of the United States and other countries worldwide. Cypress reserves all rights under such laws and treaties and does not, except as specifically stated in this paragraph, grant any license under its patents, copyrights, trademarks, or other intellectual property rights. If the Software is not accompanied by a license agreement and you do not otherwise have a written agreement with Cypress governing the use of the Software, then Cypress hereby grants you a personal, non-exclusive, nontransferable license (without the right to sublicense) (1) under its copyright rights in the Software (a) for Software provided in source code form, to modify and reproduce the Software solely for use with Cypress hardware products, only internally within your organization, and (b) to distribute the Software in binary code form externally to end users (either directly or indirectly through resellers and distributors), solely for use on Cypress hardware product units, and (2) under those claims of Cypress's patents that are infringed by the Software (as provided by Cypress, unmodified) to make, use, distribute, and import the Software solely for use with Cypress hardware products. Any other use, reproduction, modification, translation, or compilation of the Software is prohibited.

TO THE EXTENT PERMITTED BY APPLICABLE LAW, CYPRESS MAKES NO WARRANTY OF ANY KIND, EXPRESS OR IMPLIED, WITH REGARD TO THIS DOCUMENT OR ANY SOFTWARE OR ACCOMPANYING HARDWARE, INCLUDING, BUT NOT LIMITED TO, THE IMPLIED WARRANTIES OF MERCHANTABILITY AND FITNESS FOR A PARTICULAR PURPOSE. To the extent permitted by applicable law, Cypress reserves the right to make changes to this document without further notice. Cypress does not assume any liability arising out of the application or use of any product or circuit described in this document. Any information provided in this document, including any sample design information or programming code, is provided only for reference purposes. It is the responsibility of the user of this document to properly design, program, and test the functionality and safety of any application made of this information and any resulting product. Cypress products are not designed, intended, or authorized for use as critical components in systems designed or intended for the operation of weapons, weapons systems, nuclear installations, life-support devices or systems, other medical devices or systems (including resuscitation equipment and surgical implants), pollution control or hazardous substances management, or other uses where the failure of the device or system could cause personal injury, death, or property damage ("Unintended Uses"). A critical component is any component of a device or system whose failure to perform can be reasonably expected to cause the failure of the device or system, or to affect its safety or effectiveness. Cypress is not liable, in whole or in part, and you shall and hereby do release Cypress from any claim, damage, or other liability arising from or related to all Unintended Uses of Cypress products. You shall indemnify and hold Cypress harmless from and against all claims, costs, damages, and other liabilities, including claims for personal injury or death, arising from or related to any Unintended Uses of Cypress products.

Cypress, the Cypress logo, Spansion, the Spansion logo, and combinations thereof, WICED, PSoC, CapSense, EZ-USB, F-RAM, and Traveo are trademarks or registered trademarks of Cypress in the United States and other countries. For a more complete list of Cypress trademarks, visit cypress.com. Other names and brands may be claimed as property of their respective owners.

Looking for pricing, stock, or lifecycle information?

Click below to explore more details on WIN SOURCE:

-  [View CY2305CSXC-1T on WIN SOURCE](#)
-  [Cypress Semiconductor Corp Information](#)

Optimize Your Supply Chain with WIN SOURCE Solutions

-  Global Sourcing Solution
-  Obsolete Management
-  Cost Control Management
-  Shortage Management
-  Alternative Solution
-  Excess Inventory Management