



**THE DATASHEET OF
CY2308SXI-1T**



Features

- Zero input-output propagation delay, adjustable by capacitive load on FBK input
- Multiple configurations, see [Available CY2308 Configurations on page 4](#) for more details
- Multiple low skew outputs
- Two banks of four outputs, three-stateable by two select inputs
- 10 MHz to 133 MHz operating range
- 75 ps typical cycle-to-cycle jitter (15 pF, 66 MHz)
- Space saving 16-pin 150 mil SOIC package or 16-pin TSSOP
- 3.3 V operation
- Industrial temperature available

Functional Description

The CY2308 is a 3.3 V Zero Delay Buffer designed to distribute high speed clocks in PC, workstation, datacom, telecom, and other high performance applications.

The part has an on-chip PLL that locks to an input clock presented on the REF pin. The PLL feedback is driven from external FBK pin, so user has flexibility to choose any one of the outputs as feedback input and connect it to FBK pin. The input-to-output skew is less than 250 ps and output-to-output skew is less than 200 ps.

The CY2308 has two banks of four outputs each that is controlled by the select inputs as shown in the table [Select Input Decoding on page 3](#). If all output clocks are not required, Bank B is three-stated. The input clock is directly applied to the output for chip and system testing purposes by the select inputs.

The CY2308 PLL enters a power down state when there are no rising edges on the REF input. In this mode, all outputs are three-stated and the PLL is turned off resulting in less than 25 μ A of current draw. The PLL shuts down in two additional cases as shown in the table [Select Input Decoding on page 3](#).

Multiple CY2308 devices accept the same input clock and distribute it in a system. In this case, the skew between the outputs of two devices is less than 700 ps.

The CY2308 is available in five different configurations as shown in the table [Available CY2308 Configurations on page 4](#).

- The CY2308-1 is the base part where the output frequencies equal the reference if there is no counter in the feedback path. The CY2308-1H is the high drive version of the -1 and rise and fall times on this device are much faster.
- The CY2308-2 enables the user to obtain 2x and 1x frequencies on each output bank. The exact configuration and output frequencies depend on the user's selection of output that drives the feedback pin.
- The CY2308-3 enables the user to obtain 4x and 2x frequencies on the outputs.
- The CY2308-4 enables the user to obtain 2x clocks on all outputs. Thus, the part is extremely versatile and is used in a variety of applications.
- The CY2308-5H is a high drive version with REF/2 on both banks.

For a complete list of related documentation, click [here](#).

Logic Block Diagram

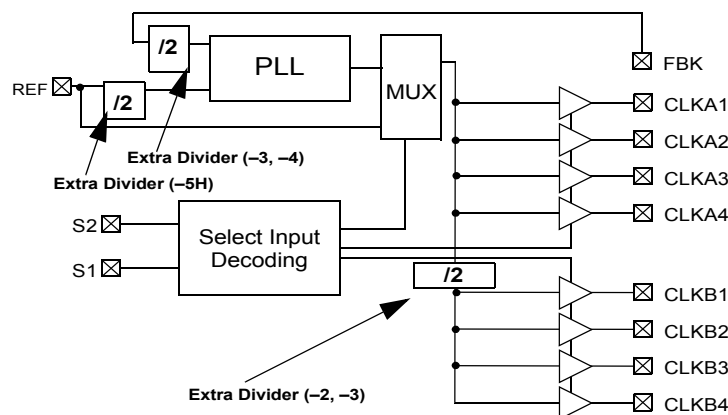

Contents

Pinouts	3	Ordering Information	13
Pin Definitions	3	Ordering Code Definitions	14
Select Input Decoding	3	Package Diagrams	15
Available CY2308 Configurations	4	Acronyms	16
Zero Delay and Skew Control	4	Document Conventions	16
Maximum Ratings	5	Units of Measure	16
Operating Conditions	5	Errata	17
Electrical Characteristics	5	Part Numbers Affected	17
Operating Conditions	6	CY2308 Errata Summary	17
Electrical Characteristics	6	CY2308 Qualification Status	17
Thermal Resistance	6	Document History Page	19
Switching Characteristics	7	Sales, Solutions, and Legal Information	21
Switching Characteristics	8	Worldwide Sales and Design Support	21
Switching Waveforms	9	Products	21
Typical Duty Cycle and IDD Trends	10	PSoC@Solutions	21
Typical Duty Cycle and IDD Trends	11	Cypress Developer Community	21
Test Circuits	12	Technical Support	21

Pinouts

Figure 1. 16-pin SOIC pinout (Top View)

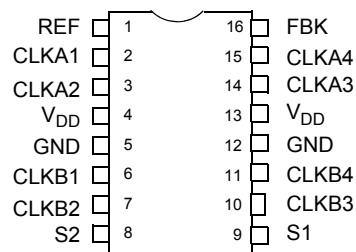

Pin Definitions

16-pin SOIC

Pin	Signal	Description
1	REF ^[1]	Input reference frequency
2	CLKA1 ^[2]	Clock output, Bank A
3	CLKA2 ^[2]	Clock output, Bank A
4	V _{DD}	Power supply voltage
5	GND	Power supply ground
6	CLKB1 ^[2]	Clock output, Bank B
7	CLKB2 ^[2]	Clock output, Bank B
8	S2 ^[3]	Select input, bit 2
9	S1 ^[3]	Select input, bit 1
10	CLKB3 ^[2]	Clock output, Bank B
11	CLKB4 ^[2]	Clock output, Bank B
12	GND	Power supply ground
13	V _{DD}	Power supply voltage
14	CLKA3 ^[2]	Clock output, Bank A
15	CLKA4 ^[2]	Clock output, Bank A
16	FBK	PLL feedback input

Select Input Decoding

S2	S1	CLOCK A1–A4	CLOCK B1–B4	Output Source	PLL Shutdown
0	0	Tri-state	Tri-state	PLL	Y
0	1	Driven	Tri-state	PLL	N
1	0	Driven ^[4]	Driven ^[4]	Reference	Y
1	1	Driven	Driven	PLL	N

Notes

1. Weak pull down.
2. Weak pull down on all outputs.
3. Weak pull ups on these inputs.
4. Outputs inverted and PLL bypass mode for 2308-2 and 2308-3, S2 = 1 and S1 = 0.

Available CY2308 Configurations

Device	Feedback From ^[5]	Bank A Frequency	Bank B Frequency
CY2308-1	Bank A or Bank B	Reference	Reference
CY2308-1H	Bank A or Bank B	Reference	Reference
CY2308-2	Bank A	Reference	Reference / 2
CY2308-2	Bank B	2 × Reference	Reference
CY2308-3	Bank A	2 × Reference	Reference ^[6]
CY2308-3	Bank B	4 × Reference	2 × Reference
CY2308-4	Bank A or Bank B	2 × Reference	2 × Reference
CY2308-5H	Bank A or Bank B	Reference / 2	Reference / 2

Zero Delay and Skew Control

Figure 2. REF. Input to CLKA/CLKB Delay Versus Difference in Loading between FBK Pin and CLKA/CLKB Pins

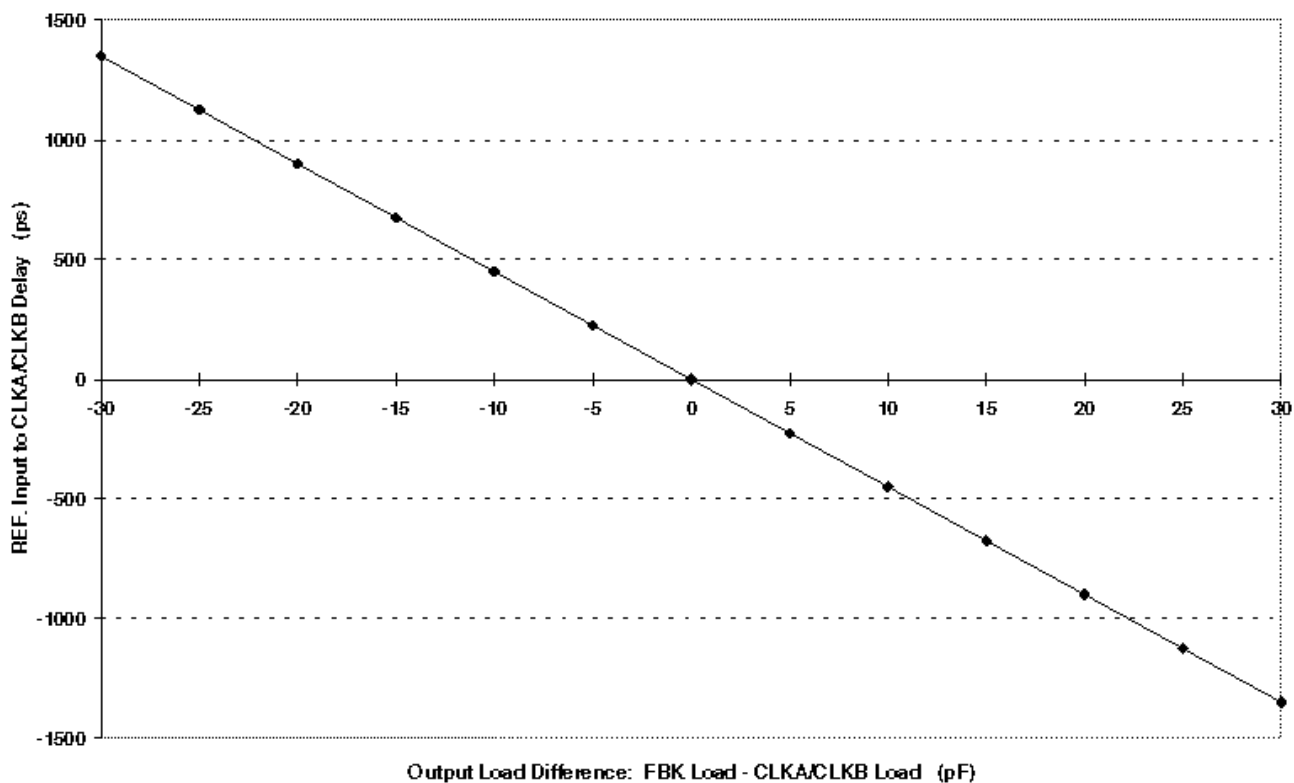

To close the feedback loop of the CY2308, the user has to connect any one of the eight available output pins to FBK pin. The output driving the FBK pin drives a total load of 7 pF plus any additional load that it drives. The relative loading of this output to the remaining outputs adjusts the input-output delay as shown in the [Figure 2](#).

For applications requiring zero input-output delay, all outputs including the one providing feedback is equally loaded.

If input-output delay adjustments are required, use the [Zero Delay and Skew Control](#) graph to calculate loading differences between the feedback output and remaining outputs.

For zero output-output skew, outputs are loaded equally. For further information on using CY2308, refer to the application note [AN1234 - Understanding Cypress's Zero Delay Buffers](#).

Notes

- 5. User has to select one of the available outputs that drive the feedback pin and need to connect selected output pin to FBK pin externally.
- 6. Output phase is indeterminate (0° or 180° from input clock). If phase integrity is required, use CY2308-2.

Maximum Ratings

Exceeding maximum ratings may shorten the useful life of the device. User guidelines are not tested.

Supply voltage to ground potential -0.5 V to +7.0 V

DC input voltage (except REF) -0.5 V to $V_{DD} + 0.5$ V

DC input voltage REF -0.5 V to 7 V

Storage temperature -65 °C to +150 °C

Junction temperature 150 °C

Static discharge voltage

(MIL-STD-883, Method 3015) >2000 V

Operating Conditions

For Commercial Temperature Devices

Parameter	Description	Min	Max	Unit
V_{DD}	Supply voltage	3.0	3.6	V
T_A	Operating temperature (ambient temperature)	0	70	°C
C_L	Load capacitance, below 100 MHz	–	30	pF
	Load capacitance, from 100 MHz to 133 MHz	–	15	pF
C_{IN}	Input capacitance [7]	–	7	pF
t_{PU}	Power up time for all V_{DD} 's to reach minimum specified voltage (power ramps must be monotonic)	0.05	50	ms

Electrical Characteristics

For Commercial Temperature Devices

Parameter	Description	Test Conditions	Min	Max	Unit
V_{IL}	Input LOW voltage		–	0.8	V
V_{IH}	Input HIGH voltage		2.0	–	V
I_{IL}	Input LOW current	$V_{IN} = 0$ V	–	50.0	μA
I_{IH}	Input HIGH current	$V_{IN} = V_{DD}$	–	100.0	μA
V_{OL}	Output LOW voltage [8]	$I_{OL} = 8$ mA (-1, -2, -3, -4) $I_{OL} = 12$ mA (-1H, -5H)	–	0.4	V
V_{OH}	Output HIGH voltage [8]	$I_{OH} = -8$ mA (-1, -2, -3, -4) $I_{OH} = -12$ mA (-1H, -5H)	2.4	–	V
I_{DD} (PD mode)	Power down supply current	REF = 0 MHz	–	12.0	μA
I_{DD}	Supply current	Unloaded outputs, 100 MHz REF, select inputs at V_{DD} or GND	–	45.0	mA
			–	70.0 (-1H, -5H)	mA
		Unloaded outputs, 66 MHz REF (-1, -2, -3, -4)	–	32.0	mA
		Unloaded outputs, 33 MHz REF (-1, -2, -3, -4)	–	18.0	mA

Notes

7. Applies to both Ref clock and FBK.

8. Parameter is guaranteed by design and characterization. Not 100% tested in production.

Operating Conditions

For Industrial Temperature Devices

Parameter	Description	Min	Max	Unit
V _{DD}	Supply voltage	3.0	3.6	V
T _A	Operating temperature (ambient temperature)	-40	85	°C
C _L	Load capacitance, below 100 MHz	-	30	pF
	Load capacitance, from 100 MHz to 133 MHz	-	15	pF
C _{IN}	Input capacitance ^[9]	-	7	pF
t _{PU}	Power up time for all V _{DDs} to reach minimum specified voltage (power ramps must be monotonic)	0.05	50	ms

Electrical Characteristics

For Industrial Temperature Devices

Parameter	Description	Test Conditions	Min	Max	Unit
V _{IL}	Input LOW voltage		-	0.8	V
V _{IH}	Input HIGH voltage		2.0	-	V
I _{IL}	Input LOW current	V _{IN} = 0 V	-	50.0	μA
I _{IH}	Input HIGH current	V _{IN} = V _{DD}	-	100.0	μA
V _{OL}	Output LOW voltage ^[10, 11]	I _{OL} = 8 mA (-1, -2, -3, -4) I _{OL} = 12 mA (-1H, -5H)	-	0.4	V
V _{OH}	Output HIGH voltage ^[10, 11]	I _{OH} = -8 mA (-1, -2, -3, -4) I _{OH} = -12 mA (-1H, -5H)	2.4	-	V
I _{DD} (PD mode)	Power down supply current	REF = 0 MHz	-	25.0	μA
I _{DD}	Supply current	Unloaded outputs, 100 MHz, Select inputs at V _{DD} or GND	-	45.0	mA
			-	70 (-1H, -5H)	mA
		Unloaded outputs, 66 MHz REF (-1, -2, -3, -4)	-	35.0	mA
		Unloaded outputs, 66 MHz REF (-1, -2, -3, -4)	-	20.0	mA

Thermal Resistance

Parameter ^[12]	Description	Test Conditions	16-pin SOIC	16-pin TSSOP	Unit
θ _{JA}	Thermal resistance (junction to ambient)	Test conditions follow standard test methods and procedures for measuring thermal impedance, in accordance with EIA/JESD51.	111	117	°C/W
θ _{JC}	Thermal resistance (junction to case)		60	22	°C/W

Notes

9. Applies to both Ref clock and FBK.
10. Parameter is guaranteed by design and characterization. Not 100% tested in production.
11. All parameters are specified with loaded outputs.
12. These parameters are guaranteed by design and are not tested.

Switching Characteristics

For Commercial Temperature Devices

Parameter ^[13]	Description	Test Conditions	Min	Typ	Max	Unit
F_{in}	Input frequency	–	10	–	133.3	MHz
t_1	Output frequency	30 pF load	10	–	100 (-1, -2, -3, -4) 66.67 (-5H)	MHz
t_1	Output frequency	20 pF load, -1H, -5H devices	10	–	133.3 (-1H) 66.67 (-5H)	MHz
t_1	Output frequency	15 pF load, -1, -2, -3, -4 devices	10	–	133.3	MHz
t_{PD}	Duty cycle ^[13] = $t_2 \div t_1$ (-1, -2, -3, -4, -1H, -5H)	Measured at 1.4 V, $F_{OUT} = 66.66$ MHz, 30 pF load	40.0	50.0	60.0	%
t_{PD}	Duty cycle ^[13] = $t_2 \div t_1$ (-1, -2, -3, -4, -1H, -5H)	Measured at 1.4 V, $F_{OUT} < 50$ MHz, 15 pF load	45.0	50.0	55.0	%
t_3	Rise time ^[13] (-1, -2, -3, -4)	Measured between 0.8 V and 2.0 V, 30 pF load	–	–	2.20	ns
t_3	Rise time ^[13] (-1, -2, -3, -4)	Measured between 0.8 V and 2.0 V, 15 pF load	–	–	1.50	ns
t_3	Rise time ^[13] (-1H, -5H)	Measured between 0.8 V and 2.0 V, 30 pF load	–	–	1.50	ns
t_4	Fall time ^[13] (-1, -2, -3, -4)	Measured between 0.8 V and 2.0 V, 30 pF load	–	–	2.20	ns
t_4	Fall time ^[13] (-1, -2, -3, -4)	Measured between 0.8 V and 2.0 V, 15 pF load	–	–	1.50	ns
t_4	Fall time ^[13] (-1H, -5H)	Measured between 0.8 V and 2.0 V, 30 pF load	–	–	1.25	ns
t_5	Output to output skew on same Bank ^[13] (-1, -2, -3, -4)	All outputs equally loaded	–	–	200	ps
	Output to output skew (-1H, -5H)	All outputs equally loaded	–	–	200	ps
	Output Bank A to output Bank B skew (-1, -4, -5H)	All outputs equally loaded	–	–	200	ps
	Output Bank A to output Bank B skew (-2, -3)	All outputs equally loaded	–	–	400	ps
t_6	Delay, REF rising edge to FBK rising edge ^[13]	Measured at $V_{DD}/2$	–	0	±250	ps
t_7	Device to device skew ^[13]	Measured at $V_{DD}/2$ on the FBK pins of devices	–	0	700	ps
t_8	Output slew rate ^[13]	Measured between 0.8 V and 2.0 V on -1H, -5H device using Test Circuit 2	1	–	–	V/ns
t_J	Cycle to cycle Jitter ^[13] (-1, -1H, -4, -5H)	Measured at 66.67 MHz, loaded outputs, 15 pF load	–	75	200	ps
		Measured at 66.67 MHz, loaded outputs, 30 pF load	–	–	200	ps
		Measured at 133.3 MHz, loaded outputs, 15 pF load	–	–	100	ps
t_J	Cycle to cycle Jitter ^[13] (-2, -3)	Measured at 66.67 MHz, loaded outputs, 30 pF load	–	–	400	ps
		Measured at 66.67 MHz, loaded outputs, 15 pF load	–	–	400	ps
t_{LOCK}	PLL lock time ^[13]	Stable power supply, valid clocks presented on REF and FBK pins	–	–	1.0	ms

Note

¹³. All parameters are specified with loaded outputs.

Switching Characteristics

For Industrial Temperature Devices

Parameter ^[14]	Description	Test Conditions	Min	Typ	Max	Unit
F_{in}	Input frequency	–	10	–	133.3	MHz
t_1	Output frequency	30 pF load	10	–	100 (-1, -2, -3, -4) 66.67 (-5H)	MHz
t_1	Output frequency	20 pF load, -1H, -5H devices	10	–	133.3 (-1H) 66.67 (-5H)	MHz
t_1	Output frequency	15 pF load, -1, -2, -3, -4 devices	10	–	133.3	MHz
t_{PD}	Duty cycle ^[14, 15] = $t_2 \div t_1$ (-1, -2, -3, -4, -1H, -5H)	Measured at 1.4 V, $F_{OUT} = 66.66$ MHz, 30 pF load	40.0	50.0	60.0	%
t_{PD}	Duty cycle ^[14, 15] = $t_2 \div t_1$ (-1, -2, -3, -4, -1H, -5H)	Measured at 1.4 V, $F_{OUT} < 50$ MHz, 15 pF load	45.0	50.0	55.0	%
t_3	Rise time ^[14, 15] (-1, -2, -3, -4)	Measured between 0.8 V and 2.0 V, 30 pF load	–	–	2.50	ns
t_3	Rise time ^[14, 15] (-1, -2, -3, -4)	Measured between 0.8 V and 2.0 V, 15 pF load	–	–	1.50	ns
t_3	Rise time ^[14, 15] (-1H, -5H)	Measured between 0.8 V and 2.0 V, 30 pF load	–	–	1.50	ns
t_4	Fall time ^[14, 15] (-1, -2, -3, -4)	Measured between 0.8 V and 2.0 V, 30 pF load	–	–	2.50	ns
t_4	Fall time ^[14, 15] (-1, -2, -3, -4)	Measured between 0.8 V and 2.0 V, 15 pF load	–	–	1.50	ns
t_4	Fall time ^[14, 15] (-1H, -5H)	Measured between 0.8 V and 2.0 V, 30 pF load	–	–	1.25	ns
t_5	Output to output skew on same Bank ^[14, 15] (-1, -2, -3, -4)	All outputs equally loaded	–	–	200	ps
	Output to output skew (-1H, -5H)	All outputs equally loaded	–	–	200	ps
	Output Bank A to output Bank B skew (-1, -4, -5H)	All outputs equally loaded	–	–	200	ps
	Output Bank A to output Bank B skew (-2, -3)	All outputs equally loaded	–	–	400	ps
t_6	Delay, REF rising edge to FBK rising edge ^[14, 15]	Measured at $V_{DD}/2$	–	0	± 250	ps
t_7	Device to device skew ^[14, 15]	Measured at $V_{DD}/2$ on the FBK pins of devices	–	0	700	ps
t_8	Output slew rate ^[14, 15]	Measured between 0.8 V and 2.0 V on -1H, -5H device using Test Circuit 2	1	–	–	V/ns
t_J	Cycle to cycle Jitter ^[14, 15] (-1, -1H, -4, -5H)	Measured at 66.67 MHz, loaded outputs, 15 pF load	–	75	200	ps
		Measured at 66.67 MHz, loaded outputs, 30 pF load	–	–	200	ps
		Measured at 133.3 MHz, loaded outputs, 15 pF load	–	–	100	ps
t_J	Cycle to cycle Jitter ^[14, 15] (-2, -3)	Measured at 66.67 MHz, loaded outputs, 30 pF load	–	–	400	ps
		Measured at 66.67 MHz, loaded outputs, 15 pF load	–	–	400	ps
t_{LOCK}	PLL lock time ^[14, 15]	Stable power supply, valid clocks presented on REF and FBK pins	–	–	1.0	ms

Notes

14. All parameters are specified with loaded outputs.

15. Parameter is guaranteed by design and characterization. Not 100% tested in production.

Switching Waveforms

Figure 3. Duty Cycle Timing

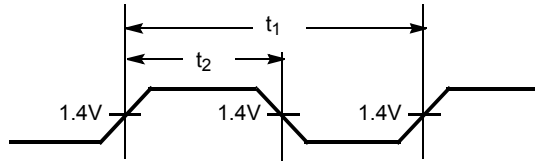

Figure 4. All Outputs Rise/Fall Time

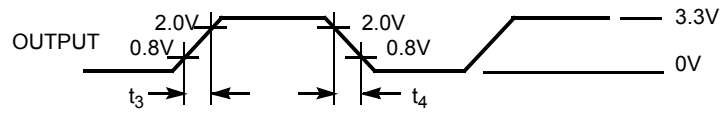

Figure 5. Output-Output Skew

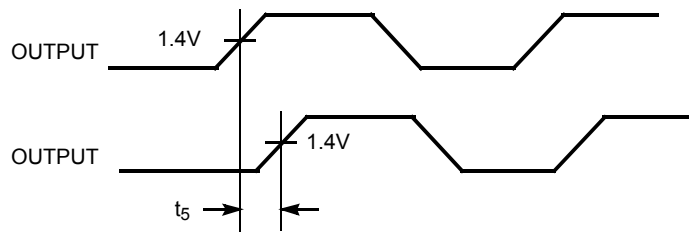

Figure 6. Input-Output Propagation Delay

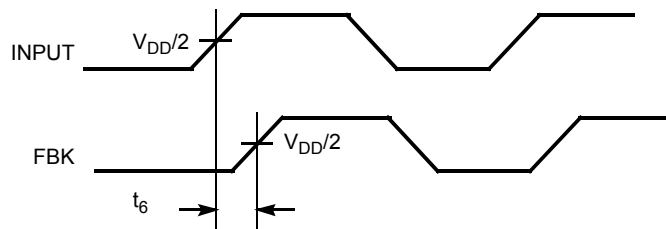
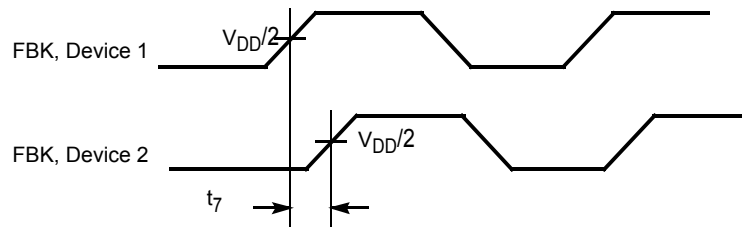
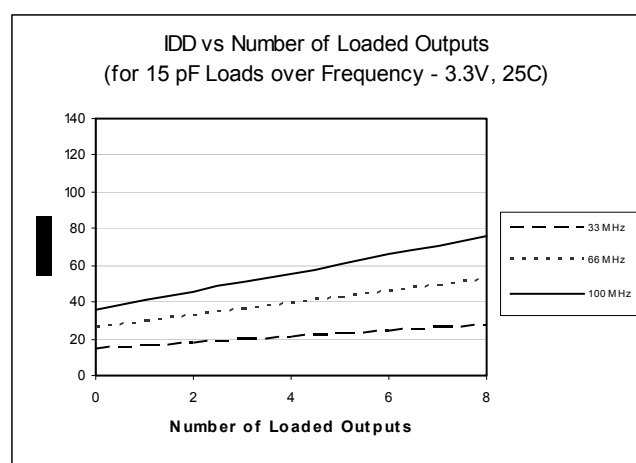
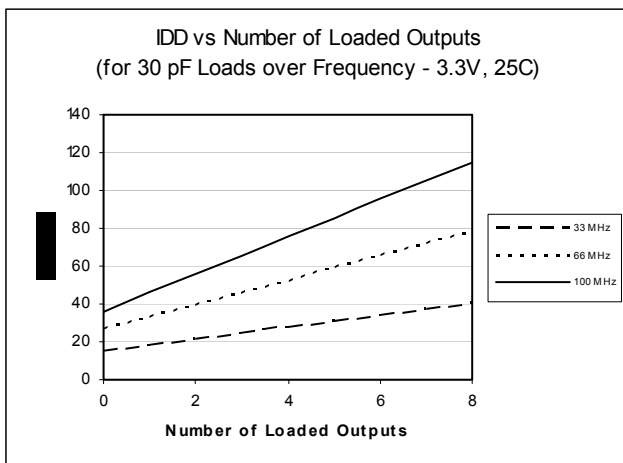
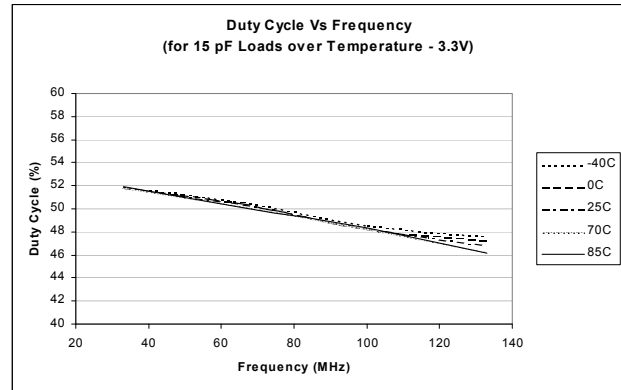
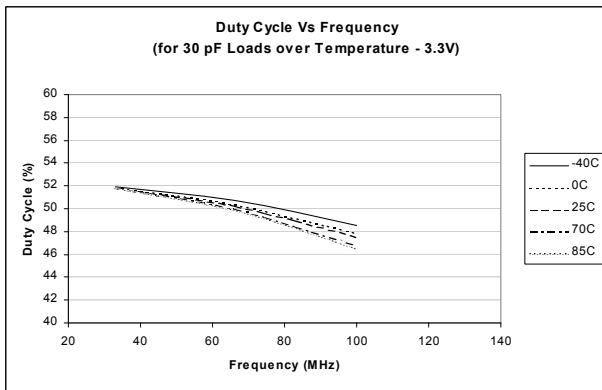
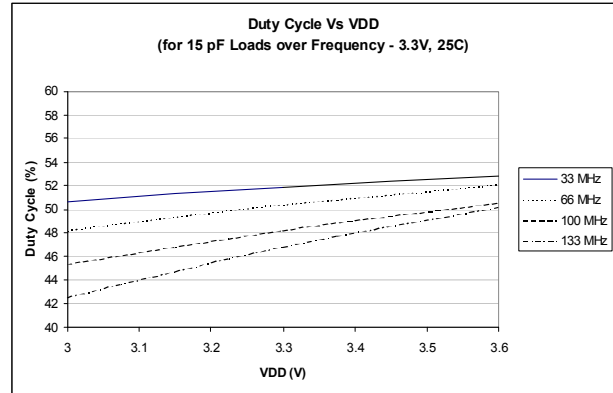
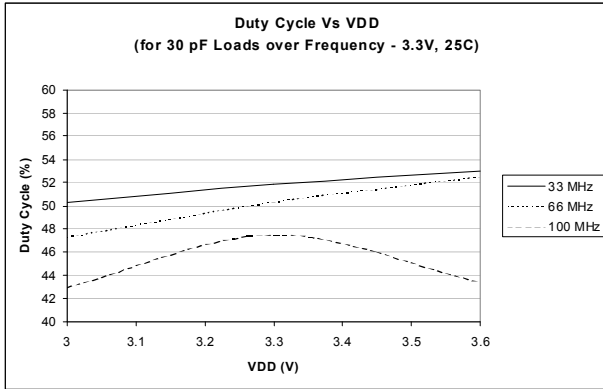

Figure 7. Device-Device Skew



Typical Duty Cycle and I_{DD} Trends

For CY2308-1, 2, 3, 4 [16, 17]



Notes

16. Duty cycle is taken from typical chip measured at 1.4 V.

17. I_{DD} data is calculated from $I_{DD} = I_{CORE} + nCVf$, where I_{CORE} is the unloaded current.
(n = number of outputs; C = Capacitance load per output (F); V = Voltage supply (V); f = frequency (Hz).

Typical Duty Cycle and I_{DD} Trends

For CY2308-1H, 5H [18, 19]

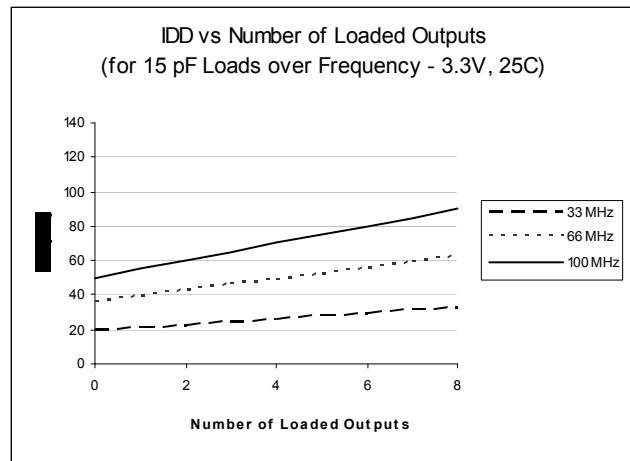
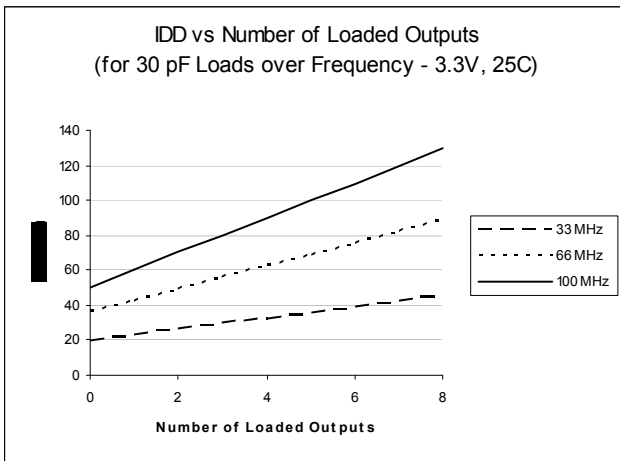
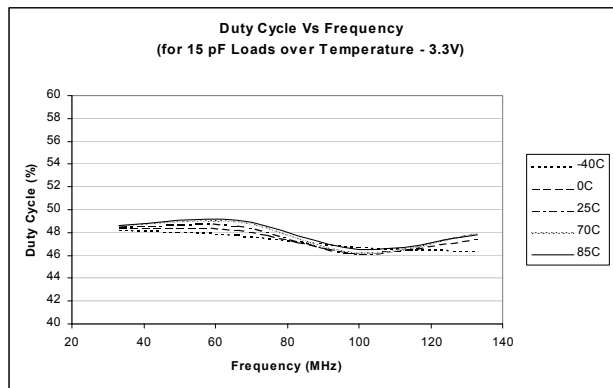
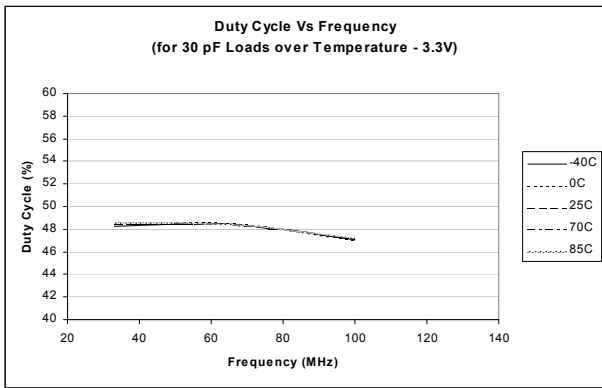
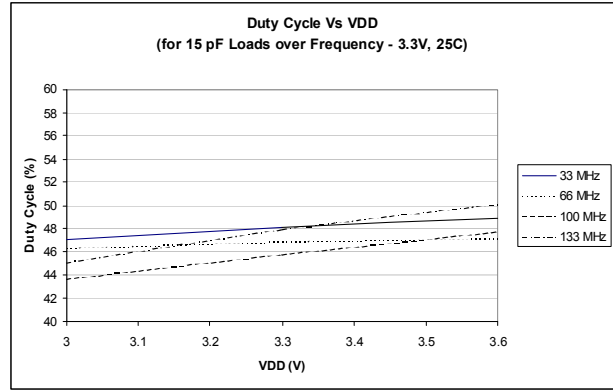
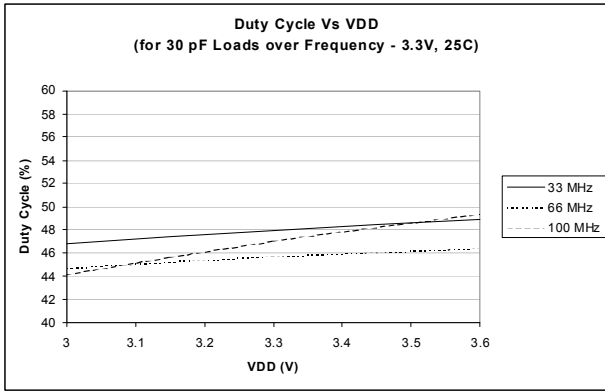

Notes

- 18. Duty cycle is taken from typical chip measured at 1.4 V.
- 19. I_{DD} data is calculated from $I_{DD} = I_{CORE} + nCVf$, where I_{CORE} is the unloaded current.
(n = number of outputs; C = Capacitance load per output (F); V = Voltage supply (V); f = frequency (Hz).

Test Circuits

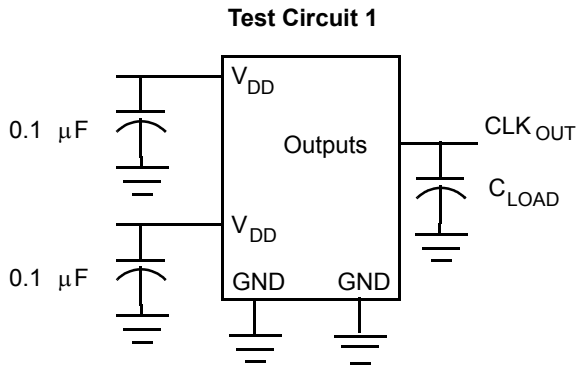

Test Circuit for all parameters except t_8

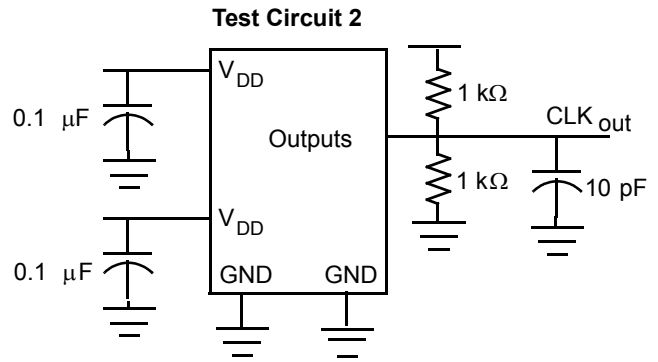

Test Circuit for t_8 , Output slew rate on -1H, -5H device

Ordering Information

Ordering Code	Package Type	Operating Range
Pb-free		
CY2308SXC-1	16-pin SOIC	Commercial
CY2308SXC-1T	16-pin SOIC – Tape and Reel	Commercial
CY2308SXI-1	16-pin SOIC	Industrial
CY2308SXI-1T	16-pin SOIC – Tape and Reel	Industrial
CY2308SXC-1H	16-pin SOIC	Commercial
CY2308SXC-1HT	16-pin SOIC – Tape and Reel	Commercial
CY2308SXI-1H	16-pin SOIC	Industrial
CY2308SXI-1HT	16-pin SOIC – Tape and Reel	Industrial
CY2308ZXC-1H	16-pin TSSOP	Commercial
CY2308ZXC-1HT	16-pin TSSOP – Tape and Reel	Commercial
CY2308ZXI-1H	16-pin TSSOP	Industrial
CY2308ZXI-1HT	16-pin TSSOP – Tape and Reel	Industrial
CY2308SXC-2	16-pin SOIC	Commercial
CY2308SXC-2T	16-pin SOIC – Tape and Reel	Commercial
CY2308SXI-2	16-pin SOIC	Industrial
CY2308SXI-2T	16-pin SOIC – Tape and Reel	Industrial
CY2308SXC-3	16-pin SOIC	Commercial
CY2308SXC-3T	16-pin SOIC – Tape and Reel	Commercial
CY2308SXI-3	16-pin SOIC	Industrial
CY2308SXI-3T	16-pin SOIC – Tape and Reel	Industrial
CY2308SXC-4	16-pin SOIC	Commercial
CY2308SXC-4T	16-pin SOIC – Tape and Reel	Commercial
CY2308SXI-4	16-pin SOIC	Industrial
CY2308SXI-4T	16-pin SOIC – Tape and Reel	Industrial

Note
20. Not recommended for new designs.

Ordering Code Definitions

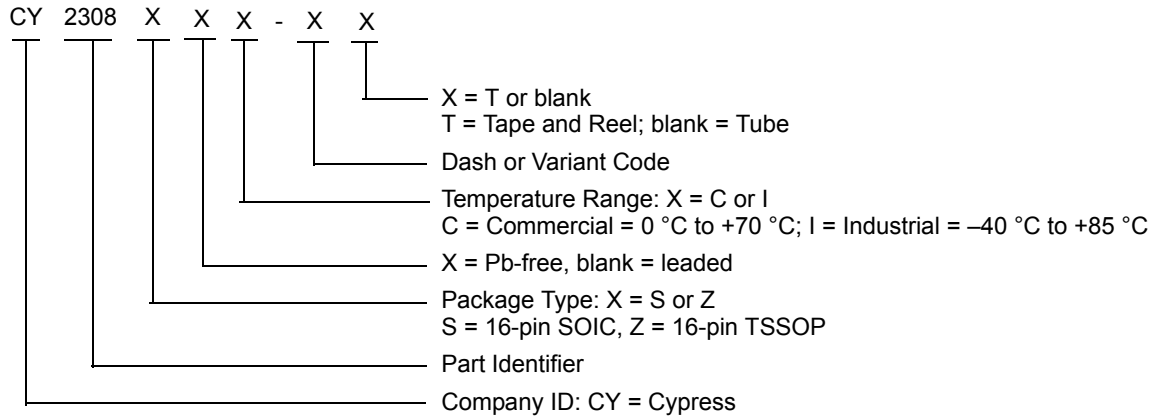

Package Diagrams

Figure 8. 16-pin SOIC (150 Mil) S16.15/SZ16.15 Package Outline, 51-85068

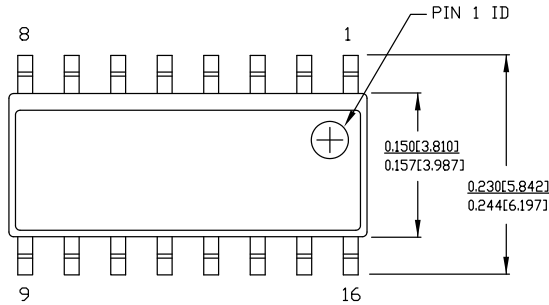

NOTE:

1. DIMENSIONS IN INCHES[MM] MAX.
2. REFERENCE JEDEC MS-012
3. PACKAGE WEIGHT : refer to PMDD spec. 001-04308

PART #	
S16.15	STANDARD PKG.
SZ16.15	LEAD FREE PKG.

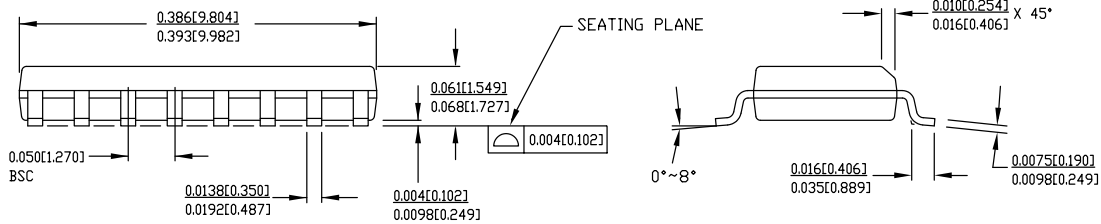

51-85068 *E

Figure 9. 16-pin TSSOP 4.40 mm Body Z16.173 Package Outline, 51-85091

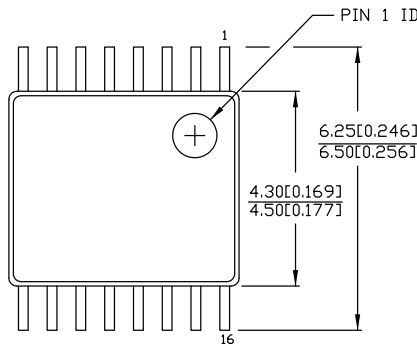

DIMENSIONS IN MM[INCHES] MIN.
MAX.

REFERENCE JEDEC MO-153
PACKAGE WEIGHT 0.05gms

PART #	
Z16.173	STANDARD PKG.
ZZ16.173	LEAD FREE PKG.

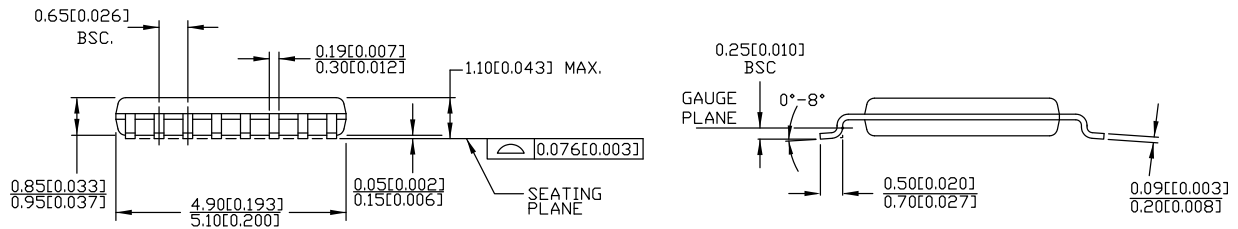

51-85091 *E

Acronyms

Table 1. Acronyms Used in this Document

Acronym	Description
FBK	Feedback
PLL	Phase Locked Loop
MUX	Multiplexer

Document Conventions

Units of Measure

Table 2. Units of Measure

Symbol	Unit of Measure	Symbol	Unit of Measure
°C	degree Celsius	μW	microwatt
dB	decibels	mA	milliampere
fC	femtocoulomb	mm	millimeter
fF	femtofarad	ms	millisecond
Hz	hertz	mV	millivolt
KB	1024 bytes	nA	nanoampere
Kbit	1024 bits	ns	nanosecond
kHz	kilohertz	nV	nanovolt
kΩ	kilohm	Ω	ohm
MHz	megahertz	pA	picoampere
MΩ	megaohm	pF	picofarad
μA	microampere	pp	peak-to-peak
μF	microfarad	ppm	parts per million
μH	microhenry	ps	picosecond
μs	microsecond	sps	samples per second
μV	microvolt	σ	sigma: one standard deviation
μVrms	microvolts root-mean-square		

Errata

This section describes the errors and workaround solution for Cypress zero delay clock buffers belonging to the families CY2308. Details include errata trigger conditions, scope of impact and available workaround.

Contact your local Cypress Sales Representative if you have questions.

Part Numbers Affected

Part Number	Device Characteristics
CY2308SXC-1	All Variants
CY2308SXC-1T	All Variants
CY2308SXI-1	All Variants
CY2308SXI-1T	All Variants
CY2308SXC-3	All Variants
CY2308SXC-3T	All Variants
CY2308SXI-3	All Variants
CY2308SXI-3T	All Variants
CY2308SXC-1H	All Variants
CY2308SXC-1HT	All Variants
CY2308SXI-1H	All Variants
CY2308SXI-1HT	All Variants
CY2308ZI-1H	All Variants
CY2308ZI-1HT	All Variants
CY2308ZXC-1H	All Variants
CY2308ZXC-1HT	All Variants
CY2308ZXI-1H	All Variants
CY2308ZXI-1HT	All Variants
CY2308ZXI-1HT	All Variants

CY2308 Errata Summary

Items	Part Number	Silicon Revision	Fix Status
1. Start up lock time issue	All	B	Silicon fixed. New silicon available from WW 10 of 2013

CY2308 Qualification Status

Product Status: In production

Qualification report last updated on 11/27/2012 (<http://www.cypress.com/?rID=72595>)

1. Start up lock time issue

■ **Problem Definition**

Output of CY2308 fails to lock within 1 ms (as per datasheet spec)

■ **Parameters Affected**

PLL lock time

■ **Trigger Condition(s)**

Powers up the device when the reference input clock is not present

■ **Scope of Impact**

The device does not lock

■ **Workaround**

Apply reference input (RefClk) before power-up (V_{DD}). If reference input is present during power up, the input noise will not propagate to output and device will start normally without problems.

■ **Fix Status**

This issue is due to design marginality where input noise propagates to output in the absence of a reference input signal during power-up, and prevents device start-up. Two minor design modifications have been made to address this problem.

- Addition of VCO bias detector block as shown in the following figure which keeps comparator power down till VCO bias is present and thereby eliminating the propagation of noise to feedback.
- Bias generator enhancement for successful initialization.

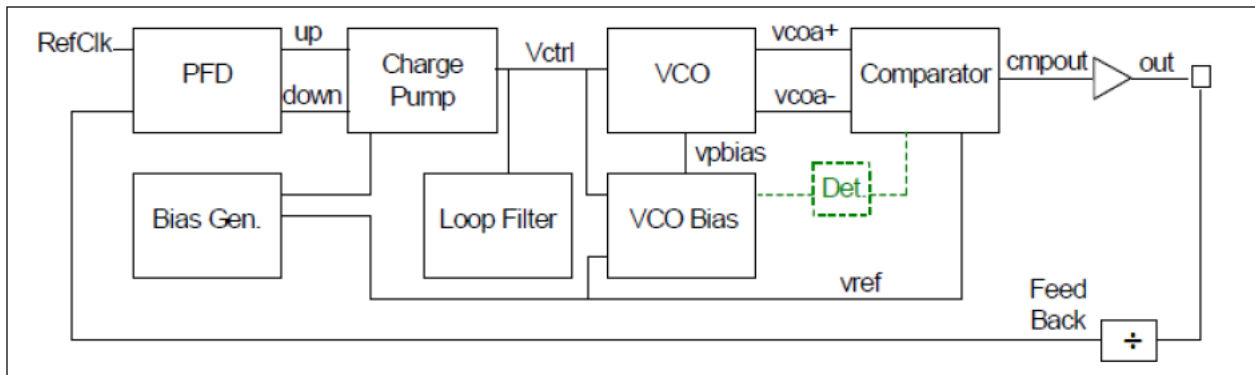

Document History Page

Document Title: CY2308, 3.3 V Zero Delay Buffer Document Number: 38-07146				
Rev.	ECN	Orig. of Change	Submission Date	Description of Change
**	110255	SZV	12/17/01	Changed from Specification number: 38-00528 to 38-07146
*A	118722	RGL	10/31/02	Added Note 4.
*B	121832	RBI	12/14/02	Power up requirements added to Operating Conditions Information
*C	235854	RGL	06/24/04	Added Pb-free Devices
*D	310594	RGL	02/09/05	Removed obsolete parts in the ordering information table Specified typical value for cycle-to-cycle jitter
*E	1344343	KVM / VED	08/20/07	Brought the Ordering Information Table up to date: removed three obsolete parts and added two parts Changed titles to tables that are specific to commercial and industrial temperature ranges
*F	2568575	AESA	09/19/08	Updated template. Added Note 20 "Not recommended for new designs." Changed IDD (PD mode) from 12.0 to 25.0 μ A for Commercial and Industrial Temperature Devices Deleted Duty Cycle parameters for $F_{out} < 50$ MHz Removed CY2308SI-4, CY2308SI-4T and CY2308SC-5HT.
*G	2632364	KVM	01/08/09	Corrected TSSOP package size (from 150 mil to 4.4 mm) in Ordering Information table
*H	2673353	KVM / PYRS	03/13/09	Reverted I_{DD} (PD mode) and Duty Cycle parameters back to the values in revision *E: Changed I_{DD} (PD mode) from 25 to 12 μ A for commercial temperature devices Added Duty Cycle parameters for $F_{out} < 50$ MHz for commercial and industrial devices.
*I	2897373	CXQ	03/22/10	Updated Ordering Information . Updated Package Diagrams . Updated copyright section.
*J	2971365	BASH	07/06/10	Updated input to output skew and power down current number in Functional Description, page 1 Update pin descriptions in 'Pin Description' column, Table1, page 2 Added 'Input Frequency' parameter and output frequency for -1H and -5H in 'Switching Characteristics Table' and removed footnote, page 4, 5, and 7. Modified Description on page 1 and page 3 to make clear that user has to select one of the outputs to drive feedback. Added footnote in 'Available CY2308 Configurations' Table, page 3, for clarification.
*K	3047133	CXQ	10/04/2010	No technical updates. Completing Sunset Review.
*L	3055192	CXQ	10/11/2010	Updated Ordering Information (Removed part CY2308SXI-5H and CY2308SXI-5HI).
*M	3402187	BASH	10/11/2011	Updated Ordering Information (Removed prune part numbers CY2308SI-1H and CY2308SI-1HT). Updated Package Diagrams . Updated to new template.
*N	4128657	CINM	10/23/2013	Updated Package Diagrams : spec 51-85068 – Changed revision from *D to *E. Updated to new template. Completing Sunset Review.
*O	4307800	CINM	03/13/2014	Added Errata .

Document History Page (continued)

Document Title: CY2308, 3.3 V Zero Delay Buffer Document Number: 38-07146				
Rev.	ECN	Orig. of Change	Submission Date	Description of Change
*P	4578443	TAVA	11/25/2014	Updated Functional Description : Added "For a complete list of related documentation, click here ." at the end. Updated Ordering Information : Removed pruned part CY2308SI-2T. Removed obsolete parts CY2308SI-1T, CY2308ZI-1H, CY2308ZI-1HT and CY2308SI-2.
*Q	5272607	PSR	05/16/2016	Updated Zero Delay and Skew Control : Updated description (Updated title and link for AN1234). Added Thermal Resistance . Updated to new template.
*R	5516682	TAVA	11/10/2016	Updated to new template. Completing Sunset Review.
*S	5638394	PRBD	02/21/2017	Corrected typo and added more clarity in Errata . Updated the template.
*T	5987007	AESATMP8	12/07/2017	Updated logo and Copyright.

Sales, Solutions, and Legal Information

Worldwide Sales and Design Support

Cypress maintains a worldwide network of offices, solution centers, manufacturer's representatives, and distributors. To find the office closest to you, visit us at [Cypress Locations](#).

Products

ARM [®] Cortex [®] Microcontrollers	cypress.com/arm
Automotive	cypress.com/automotive
Clocks & Buffers	cypress.com/clocks
Interface	cypress.com/interface
Internet of Things	cypress.com/iot
Memory	cypress.com/memory
Microcontrollers	cypress.com/mcu
PSoC	cypress.com/psoc
Power Management ICs	cypress.com/pmic
Touch Sensing	cypress.com/touch
USB Controllers	cypress.com/usb
Wireless Connectivity	cypress.com/wireless

PSoC[®] Solutions

[PSoC 1](#) | [PSoC 3](#) | [PSoC 4](#) | [PSoC 5LP](#) | [PSoC 6](#)

Cypress Developer Community

[Forums](#) | [WICED IOT Forums](#) | [Projects](#) | [Video](#) | [Blogs](#) | [Training](#) | [Components](#)

Technical Support

cypress.com/support



© Cypress Semiconductor Corporation, 2001-2017. This document is the property of Cypress Semiconductor Corporation and its subsidiaries, including Spansion LLC ("Cypress"). This document, including any software or firmware included or referenced in this document ("Software"), is owned by Cypress under the intellectual property laws and treaties of the United States and other countries worldwide. Cypress reserves all rights under such laws and treaties and does not, except as specifically stated in this paragraph, grant any license under its patents, copyrights, trademarks, or other intellectual property rights. If the Software is not accompanied by a license agreement and you do not otherwise have a written agreement with Cypress governing the use of the Software, then Cypress hereby grants you a personal, non-exclusive, nontransferable license (without the right to sublicense) (1) under its copyright rights in the Software (a) for Software provided in source code form, to modify and reproduce the Software solely for use with Cypress hardware products, only internally within your organization, and (b) to distribute the Software in binary code form externally to end users (either directly or indirectly through resellers and distributors), solely for use on Cypress hardware product units, and (2) under those claims of Cypress's patents that are infringed by the Software (as provided by Cypress, unmodified) to make, use, distribute, and import the Software solely for use with Cypress hardware products. Any other use, reproduction, modification, translation, or compilation of the Software is prohibited.

TO THE EXTENT PERMITTED BY APPLICABLE LAW, CYPRESS MAKES NO WARRANTY OF ANY KIND, EXPRESS OR IMPLIED, WITH REGARD TO THIS DOCUMENT OR ANY SOFTWARE OR ACCOMPANYING HARDWARE, INCLUDING, BUT NOT LIMITED TO, THE IMPLIED WARRANTIES OF MERCHANTABILITY AND FITNESS FOR A PARTICULAR PURPOSE. To the extent permitted by applicable law, Cypress reserves the right to make changes to this document without further notice. Cypress does not assume any liability arising out of the application or use of any product or circuit described in this document. Any information provided in this document, including any sample design information or programming code, is provided only for reference purposes. It is the responsibility of the user of this document to properly design, program, and test the functionality and safety of any application made of this information and any resulting product. Cypress products are not designed, intended, or authorized for use as critical components in systems designed or intended for the operation of weapons, weapons systems, nuclear installations, life-support devices or systems, other medical devices or systems (including resuscitation equipment and surgical implants), pollution control or hazardous substances management, or other uses where the failure of the device or system could cause personal injury, death, or property damage ("Unintended Uses"). A critical component is any component of a device or system whose failure to perform can be reasonably expected to cause the failure of the device or system, or to affect its safety or effectiveness. Cypress is not liable, in whole or in part, and you shall and hereby do release Cypress from any claim, damage, or other liability arising from or related to all Unintended Uses of Cypress products. You shall indemnify and hold Cypress harmless from and against all claims, costs, damages, and other liabilities, including claims for personal injury or death, arising from or related to any Unintended Uses of Cypress products.

Cypress, the Cypress logo, Spansion, the Spansion logo, and combinations thereof, WICED, PSoC, CapSense, EZ-USB, F-RAM, and Traveo are trademarks or registered trademarks of Cypress in the United States and other countries. For a more complete list of Cypress trademarks, visit cypress.com. Other names and brands may be claimed as property of their respective owners.

Looking for pricing, stock, or lifecycle information?

Click below to explore more details on WIN SOURCE:

-  [View CY2308SXI-1T on WIN SOURCE](#)
-  [Cypress Semiconductor Corp](#) Information

Optimize Your Supply Chain with WIN SOURCE Solutions

-  Global Sourcing Solution
-  Obsolete Management
-  Cost Control Management
-  Shortage Management
-  Alternative Solution
-  Excess Inventory Management