



**THE DATASHEET OF
SMC128CFB6E**



Features

- Custom-designed, highly-integrated memory controller
 - Fully compliant with CompactFlash™ specification 3.0
 - Fully compatible with PCMCIA specification 2.1
 - PC Card ATA interface supported
 - True IDE mode compatible
 - Up to PIO mode 6 supported
 - Up to 4 multi-word DMA supported
 - Hardware RS-ECC (4 symbols in a 512-byte sector)
 - Up to mode 4 UDMA
- Small form factor
 - 36.4 mm x 42.8 mm x 3.3 mm
- Low-power CMOS technology
- 3.3 V / 5 V power supply
- Power saving mode (with automatic wake-up)
- Hot swappable
- Flash memory power-down logic and write protect control
- Power loss protection

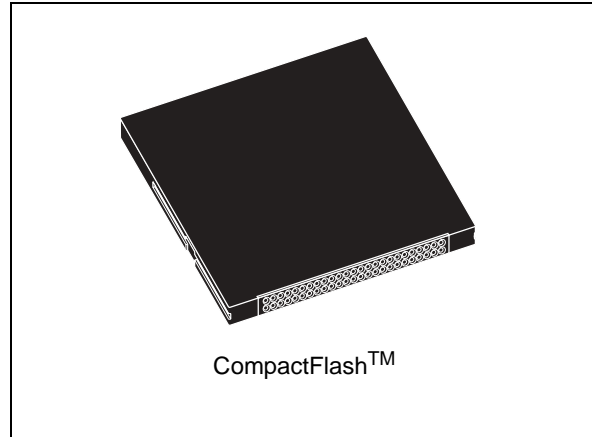

- High performance
 - Up to 66 Mbyte/s transfer rate
 - Sustained write performance (host to card): 18.3 Mbyte/s
 - Sustained read performance (host to card): 41.8 Mbyte/s
- Available densities (formatted)
 - 128 Mbytes, 1 Gbyte and 8 Gbytes
- Operating system support
 - Standard software drivers operation

Table 1. Device summary

Reference	Root part number	Package form factor	Operating voltage range
SMCxxxCF	SMC128CF	CF type I	3.3 V + 10%, 5 V + 10%
	SMC01GCF		
	SMC08GCF		

Contents

- 1 Description 5**
- 2 Capacity specification 7**
- 3 Card physical 8**
 - 3.1 Physical description 8
- 4 Electrical interface 9**
 - 4.1 Electrical description 9
 - 4.2 Electrical specification 17
 - 4.3 Current measurement 17
 - 4.4 Additional requirements for CompactFlash advanced timing mode 18
- 5 Command interface 19**
- 6 Card configuration 20**
- 7 Host configuration requirements 20**
- 8 Software interface 20**
- 9 CF-ATA registers 20**
- 10 CF-ATA command description 20**
- 11 CIS information (typical) 21**
- 12 Package mechanical 26**
- 13 Ordering information 27**
- 14 Revision history 28**

List of tables

Table 1.	Device summary	1
Table 2.	System performance.	6
Table 3.	Current consumption	6
Table 4.	Environmental specifications	6
Table 5.	Physical dimensions	6
Table 6.	CF capacity specification	7
Table 7.	Pin assignment and pin type.	9
Table 8.	Signals description	11
Table 9.	Absolute maximum conditions	17
Table 10.	Input power	17
Table 11.	Input leakage current	17
Table 12.	Input characteristics	18
Table 13.	Output drive type	18
Table 14.	Output drive characteristics	18
Table 15.	Ordering information scheme	27
Table 16.	Document revision history	28

List of figures

Figure 1.	CompactFlash memory card block diagram	8
Figure 2.	Type I CompactFlash memory card dimensions.	26

1 Description

The CompactFlash is a small form factor non-volatile memory card which provides high capacity data storage. Its aim is to capture, retain and transport data, audio and images, facilitating the transfer of all types of digital information between a large variety of digital systems.

The card operates in three basic modes:

- PCMCIA I/O mode
- PCMCIA memory mode
- True IDE mode

The CompactFlash also supports advanced timing modes. Advanced timing modes are PCMCIA style I/O modes that are 100 ns or faster, PCMCIA memory modes that are 100 ns or faster, true IDE PIO up to mode 6, multi-word DMA up to mode 4, and UDMA up to mode 4.

It conforms to the PC card specification when operating in the PCMCIA I/O mode, and in the PCMCIA memory mode (personal computer memory card international association standard, JEIDA in Japan), and to the ATA specification when operating in true IDE mode. CompactFlash cards can be used with passive adapters in a PC-card type II or type III socket.

The card has an internal intelligent controller which manages interface protocols, data storage and retrieval as well as hardware RS-code error correction code (ECC), defect handling, diagnostics and clock control. Once the card has been configured by the host, it behaves as a standard ATA (IDE) disk drive. The hardware RS-code ECC allows to detect and correct 4 bytes per 512 bytes.

The specification has been realized and approved by the CompactFlash association (CFA). This non-proprietary specification enables users to develop CF products that function correctly and are compatible with future CF design.

The system highlights are shown in [Table 2](#), [Table 3](#), [Table 4](#), [Table 5](#), and [Table 6](#).

Related documentation

- PCMCIA PC card standard, 1995
- PCMCIA PC card ATA specification, 1995
- AT attachment interface document, american national standards institute, X3.221-1994
- CF+ and CompactFlash specification revision 3.0.

Table 2. System performance

System performance		Max	Unit
Sleep to write		0.022	ms
Sleep to read		0.070	ms
Power-up to ready		493	ms
Data transfer rate (burst)		66 (440X) ⁽¹⁾	Mbyte/s
Sustained read		41.8 (278X) ⁽¹⁾	Mbyte/s
Sustained write		18.3 (122X) ⁽¹⁾	Mbyte/s
Command to DRQ	Read	33.7	μs
	Write	8.5	

1. 440X, 278X and 122X, speed grade markings where 1X = 150 Kbytes/s. All values are measured for an ambient temperature of 25 °C. They refer to the 1-Gbyte CompactFlash card in PIO mode 6, cycle time 80 ns, File size = 20 Mbytes sequential; sector count = 256.

Table 3. Current consumption⁽¹⁾

Current consumption (typ)	3.3 V	5 V	Unit
Read	32	44	mA
Write	79	83	mA
Standby	0.5	0.5	mA
Sleep mode	0.5	0.5	mA

1. All values are typical at 25 °C and nominal supply voltage and refer to 1-Gbyte CompactFlash card, operating in PIO mode.

Table 4. Environmental specifications

Environmental specifications	Operating	Non-operating
Temperature	-40 to 85 °C	-50 to 100 °C
Humidity (non-condensing)	N/A	85% RH, at 85 °C
Salt water spray	N/A	3% NaCl at 35 °C ⁽¹⁾
Vibration (peak -to-peak)	N/A	30Gmax.
Shock	N/A	3,000Gmax.

1. MIL STD METHOD 1009.

Table 5. Physical dimensions

Physical dimensions		Unit
Width	42.8	mm
Height	36.4	mm
Thickness	3.3	mm
Weight (typ.)	10	g

2 Capacity specification

[Table 6](#) shows the specific capacity for the various CF models and the default number of heads, sector/tracks and cylinders.

Table 6. CF capacity specification

Root part number	Capacity	Default_cylinders	Default_heads	Default_sectors_track	Sectors_card	Addressable capacity (byte)
SMC128CF	128 Mbytes	994	8	32	254,464	130,285,568
SMC01GCF	1 Gbyte	1,991	16	63	2,006,928	1,003,464,000
SMC08GCF	8 Gbytes	15,949	16	63	16,055,424	8,231,215,104

3 Card physical

3.1 Physical description

The CompactFlash memory card contains a single chip controller and flash memory module(s). The controller interfaces with a host system allowing data to be written to and read from the flash memory module(s). *Figure 1* shows the block diagram of the CompactFlash memory card.

The card is offered in a type I package with a 50-pin connector consisting of two rows of 25 female contacts on 50 mil (1.27 mm) centers. *Figure 2* shows type I card dimensions.

Figure 1. CompactFlash memory card block diagram

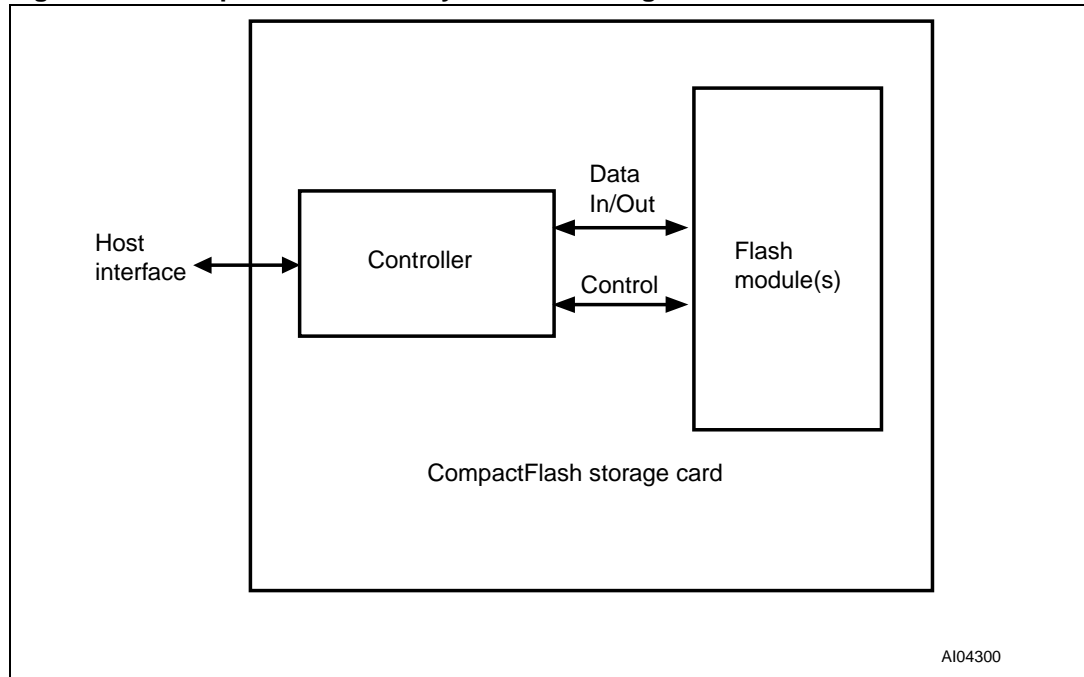

4 Electrical interface

4.1 Electrical description

The CompactFlash memory card operates in three basic modes:

- PC card ATA using I/O mode
- PC card ATA using memory mode
- True IDE mode, which is compatible with most disk drives.

The signal/pin assignments are listed in [Table 7](#) Low active signals have a '-' prefix. Pin types are input, output or input/output.

The configuration of the card is controlled using the standard PCMCIA configuration registers starting at address 200h in the attribute memory space of the memory card.

[Table 8](#) describes the I/O signals. Inputs are signals sourced from the host while outputs are signals sourced from the card. The signals are described for each of the three operating modes.

All outputs from the card are totem pole except the data bus signals that are bi-directional tri-state. Refer to the [Section 4.2: Electrical specification](#) for definitions of input and output type.

Table 7. Pin assignment and pin type

Pin num	PC card memory mode			PC card I/O mode			True IDE mode		
	Signal name	Pin type	In, Out type	Signal name	Pin type	In, Out type	Signal name	Pin type	In, Out type
1	GND		Ground	GND		Ground	GND		Ground
2	D03	I/O	I1Z,OZ3	D03	I/O	I1Z,OZ3	D03	I/O	I1Z,OZ3
3	D04	I/O	I1Z,OZ3	D04	I/O	I1Z,OZ3	D04	I/O	I1Z,OZ3
4	D05	I/O	I1Z,OZ3	D05	I/O	I1Z,OZ3	D05	I/O	I1Z,OZ3
5	D06	I/O	I1Z,OZ3	D06	I/O	I1Z,OZ3	D06	I/O	I1Z,OZ3
6	D07	I/O	I1Z,OZ3	D07	I/O	I1Z,OZ3	D07	I/O	I1Z,OZ3
7	-CE1	I	I3U	-CE1	I	I3U	-CS0	I	I3Z
8	A10	I	I1Z	A10	I	I1Z	A10 ⁽²⁾	I	I1Z
9 ⁽¹⁾	-OE	I	I3U	-OE	I	I3U	-ATASEL	I	I3U
10	A09	I	I1Z	A09	I	I1Z	A09 ⁽²⁾	I	I1Z
11	A08	I	I1Z	A08	I	I1Z	A08 ⁽²⁾	I	I1Z
12	A07	I	I1Z	A07	I	I1Z	A07 ⁽²⁾	I	I1Z
13	V _{CC}		Power	V _{CC}		Power	V _{CC}		Power
14	A06	I	I1Z	A06	I	I1Z	A06 ⁽²⁾	I	I1Z
15	A05	I	I1Z	A05	I	I1Z	A05 ⁽²⁾	I	I1Z
16	A04	I	I1Z	A04	I	I1Z	A04 ⁽²⁾	I	I1Z

Table 7. Pin assignment and pin type (continued)

Pin num	PC card memory mode			PC card I/O mode			True IDE mode		
	Signal name	Pin type	In, Out type	Signal name	Pin type	In, Out type	Signal name	Pin type	In, Out type
17	A03	I	I1Z	A03	I	I1Z	A03 ⁽²⁾	I	I1Z
18	A02	I	I1Z	A02	I	I1Z	A02	I	I1Z
19	A01	I	I1Z	A01	I	I1Z	A01	I	I1Z
20	A00	I	I1Z	A00	I	I1Z	A00	I	I1Z
21	D00	I/O	I1Z,OZ3	D00	I/O	I1Z,OZ3	D00	I/O	I1Z,OZ3
22	D01	I/O	I1Z,OZ3	D01	I/O	I1Z,OZ3	D01	I/O	I1Z,OZ3
23	D02	I/O	I1Z,OZ3	D02	I/O	I1Z,OZ3	D02	I/O	I1Z,OZ3
24	WP	O	OT3	-IOIS16	O	OT3	-IOIS16	O	ON3
25	-CD2	O	Ground	-CD2	O	Ground	-CD2	O	Ground
26	-CD1	O	Ground	-CD1	O	Ground	-CD1	O	Ground
27	D11 ⁽³⁾	I/O	I1Z,OZ3	D11 ⁽³⁾	I/O	I1Z,OZ3	D11 ⁽³⁾	I/O	I1Z,OZ3
28	D12 ⁽³⁾	I/O	I1Z,OZ3	D12 ⁽³⁾	I/O	I1Z,OZ3	D12 ⁽³⁾	I/O	I1Z,OZ3
29	D13 ⁽³⁾	I/O	I1Z,OZ3	D13 ⁽³⁾	I/O	I1Z,OZ3	D13 ⁽³⁾	I/O	I1Z,OZ3
30	D14 ⁽³⁾	I/O	I1Z,OZ3	D14 ⁽³⁾	I/O	I1Z,OZ3	D14 ⁽³⁾	I/O	I1Z,OZ3
31	D15 ⁽³⁾	I/O	I1Z,OZ3	D15 ⁽³⁾	I/O	I1Z,OZ3	D15 ⁽³⁾	I/O	I1Z,OZ3
32	-CE2 ⁽³⁾	I	I3U	-CE2 ⁽³⁾	I	I3U	-CS1 ⁽³⁾	I	I3Z
33	-VS1	O	Ground	-VS1	O	Ground	-VS1	O	Ground
34	-IORD	I	I3U	-IORD	I	I3U	-IORD HSTROBE -HDMARDY	I	I3Z
35	-IOWR	I	I3U	-IOWR	I	I3U	-IOWR STOP	I	I3Z
36	-WE	I	I3U	-WE	I	I3U	-WE ⁽⁴⁾	I	I3U
37	READY	O	OT1	-IREQ	O	OT1	INTRQ	O	OZ1
38	V _{CC}		Power	V _{CC}		Power	V _{CC}		Power
39	-CSEL ⁽⁵⁾⁽³⁾	I	I2Z	-CSEL ⁽⁵⁾	I	I2Z	-CSEL ⁽⁵⁾	I	I2U
40	-VS2	O	OPEN	-VS2	O	OPEN	-VS2	O	OPEN
41	RESET	I	I2Z	RESET	I	I2Z	-RESET	I	I2Z
42	-WAIT	O	OT1	-WAIT	O	OT1	IORDY -DDMARDY DSTROBE	O	ON1
43	-INPACK	O	OT1	-INPACK	O	OT1	DMARQ	O	OZ1
44	-REG	I	I3U	-REG	I	I3U	-DMACK ⁽⁶⁾	I	I3U
45	BVD2	I/O	I1U,OT1	-SPKR	I/O	I1U,OT1	-DASP	I/O	I1U,ON1

Table 7. Pin assignment and pin type (continued)

Pin num	PC card memory mode			PC card I/O mode			True IDE mode		
	Signal name	Pin type	In, Out type	Signal name	Pin type	In, Out type	Signal name	Pin type	In, Out type
46	BVD1	I/O	I1U,OT1	-STSCHG	I/O	I1U,OT1	-PDIAG	I/O	I1U,ON1
47	D08 ⁽³⁾	I/O	I1Z,OZ3	D08 ⁽³⁾	I/O	I1Z,OZ3	D08 ⁽³⁾	I/O	I1Z,OZ3
48	D09 ⁽³⁾	I/O	I1Z,OZ3	D09 ⁽³⁾	I/O	I1Z,OZ3	D09 ⁽³⁾	I/O	I1Z,OZ3
49	D10 ⁽³⁾	I/O	I1Z,OZ3	D10 ⁽³⁾	I/O	I1Z,OZ3	D10 ⁽³⁾	I/O	I1Z,OZ3
50	GND		Ground	GND		Ground	GND		Ground

- For True IDE mode, pin 9 is grounded.
- The signal should be grounded by the host.
- These signals are required only for 16-bit accesses and not required when installed in 8-bit systems. Devices should allow for 3-state signals not to consume current.
- The signal should be tied to V_{CC} by the host.
- The -CSEL signal is ignored by the card in PC card modes. However, because it is not pulled up on the card in these modes it should not be left floating by the host in PC card modes. In these modes, the pin is normally connected by the host to PC card A25 or grounded by the host.
- When the device does not operate in DMA mode, the signal should be held High or tied to V_{CC} by the host. To ensure proper operation with older hosts when DMA mode is disabled, the card should ignore the -DMACK signal.

Table 8. Signals description

Signal name	Dir.	Pin	Description
A10 to A0 (PC card memory mode)	I	8,10,11,12, 14,15,16,17, 18,19,20	Used (with -REG) to select: the I/O port address registers, the memory mapped port address registers, a byte in the card information structure and its configuration control and status registers.
A10 to A0 (PC card I/O mode)			Same as PC card memory mode
A2 to A0 (True IDE mode)			Only A2 to A0 are used to select the one of eight registers in the task file, the remaining lines should be grounded.
BVD1 (PC card memory mode)	I/O	46	The battery voltage status of the card, as no battery is required it is asserted High.
-STSCHG (PC card I/O mode)			Alerts the host to changes in the ready and write protect states. Its use is controlled by the card configuration and status register.
-PDIAG (True IDE mode)			The Pass Diagnostic signal in the master/slave handshake protocol.
BVD2 (PC card memory mode)	I/O	45	The battery voltage status of the card, as no battery is required it is asserted High.
-SPKR (PC card I/O mode)			The Binary Audio output from the card. It is asserted High as audio functions are not supported.
-DASP (True IDE mode)			This input/output is the Disk Active/Slave Present signal in the master/slave handshake protocol.

Table 8. Signals description (continued)

Signal name	Dir.	Pin	Description
D15-D00 (PC card memory mode)	I/O	31,30,29,28, 27,49,48,47, 6,5,4,3,2, 23,22,21	Carry the data, commands and status information between the host and the controller. D00 is the LSB of the even byte of the word. D08 is the LSB of the odd byte of the word.
D15-D00 (PC card I/O mode)			Same as PC card memory mode.
D15-D00 (True IDE mode)			All task file operations occur in byte mode on D00 to D07 while all data transfers are 16 bits using D00 to D15.
GND (PC card memory mode)		1,50	Ground.
GND (PC card I/O mode)			Same for all modes.
GND (True IDE mode)			Same for all modes.
-INPACK (PC card memory mode)	O	43	Not used, should not be connected to the host.
-INPACK (PC card I/O mode)			The input acknowledge is asserted when the card is selected and responding to an I/O read cycle at the current address on the bus. It is used by the host to control the enable of any input data buffers between the card and CPU.
DMARQ (True IDE mode)			The DMARQ input signal is used to request a DMA data transfer between the host and the card. It is asserted to notify that the card is ready to transfer data to or from the host. For multi-word DMA transfers, the direction of data transfer is controlled by -IORD and -LOWR. DMARQ is used in conjunction with -DMACK to perform handshaking: the card waits until -DMACK has been asserted by the host to de-assert DMARQ, and re-assert it again if there is still data to be transferred. DMARQ is not driven when the card is not selected. If the host does not support DMA mode, DMARQ should be left unconnected.

Table 8. Signals description (continued)

Signal name	Dir.	Pin	Description
-IORD (PC card memory mode)	I	34	Not used.
-IORD (PC card I/O mode)			I/O read strobe generated by the host. It gates I/O data onto the bus.
-IORD (True IDE mode - except Ultra DMA Protocol Active)			In True IDE mode, while Ultra DMA mode is not active, this signal has the same function as in PC Card I/O mode.
-HDMARDY (True IDE mode - in Ultra DMA Protocol DMA Read)			In True IDE mode when Ultra DMA mode DMA Read is active, this signal is asserted by the host to indicate that the host is read to receive Ultra DMA data-in bursts. The host may negate -HDMARDY to pause an Ultra DMA transfer.
-HSTROBE (True IDE mode - in Ultra DMA Protocol DMA Write)			In True IDE mode when Ultra DMA mode DMA Write is active, this signal is the data out strobe generated by the host. Both the rising and falling edge of HSTROBE cause data to be latched by the device. The host may stop generating HSTROBE edges to pause an Ultra DMA data-out burst.
-CD1, -CD2 (PC card memory mode)	O	26,25	These are connected to ground on the card. They are used by the host to determine that the card is fully inserted into its socket.
-CD1, -CD2 (PC card I/O mode)			Same for all modes.
-CD1, -CD2 (True IDE mode)			Same for all modes.
-CE1, -CE2 (PC card memory mode)	I	7,32	Used to select the card and to indicate whether a byte or a word operation is being performed. -CE2 accesses the odd Byte, -CE1 accesses the even byte or the odd byte depending on A0 and -CE2. A multiplexing scheme based on A0, -CE1, -CE2 allows 8-bit hosts to access all data on D0 to D7.
-CE1, -CE2 (PC card I/O mode)			Same as PC card memory mode.
-CS0, -CS1 (True IDE mode)			-CS0 is the chip select for the task file registers, while -CS1 selects the alternate status register and the device control register. When -DMACK is asserted, -CS0 and -CS1 must be de-asserted and data width is 16 bits.
-CSEL (PC card memory mode)	I	39	Not used.
-CSEL (PC card I/O mode)			Not used.
-CSEL (True IDE mode)			This internally pulled up signal is used to configure the card as a master or slave. When grounded it is configured as a master, when open it is configured as a slave.

Table 8. Signals description (continued)

Signal name	Dir.	Pin	Description
-IOWR (PC card memory mode)	I	35	Not used.
-IOWR (PC card I/O mode)			The I/O write strobe pulse is used to clock I/O data on the bus into the card controller registers. Clocking occurs on the rising edge.
-IOWR (True IDE mode - except Ultra DMA Protocol Active)			In True IDE mode, while Ultra DMA mode protocol is not active, this signal has the same function as in PC Card I/O mode. When Ultra DMA mode protocol is supported, this signal must be negated before entering Ultra DMA mode protocol.
-STOP (True IDE mode - Ultra DMA Protocol Active)			In True IDE mode, while Ultra DMA mode protocol is active, the assertion of this signal causes the termination of the Ultra DMA burst.
-OE (PC card memory mode)	I	9	This is an Output Enable strobe generated by the host interface. It reads data and the CIS and configuration registers.
-OE (PC card I/O mode)			Reads the CIS and configuration registers.
-ATASEL (True IDE mode)			This input signal must be driven Low to enable true IDE mode.
READY (PC card memory mode)	O	37	Indicates whether the card is busy (Low), or ready to accept a new data transfer operation (High). The host socket must provide a pull-up resistor. At power-up and reset, the Ready signal is held Low until the commands are completed. No access should be made during this time. The Ready signal is held High whenever the card has been powered up with Reset continuously disconnected or asserted.
-IREQ (PC card I/O mode)			Interrupt request. It is strobed Low to generate a pulse mode interrupt or held Low for a level mode interrupt.
INTRQ (True IDE mode)			Active High interrupt request to the host.
-REG (PC card memory mode)	I	44	Used to distinguish between common memory and register (attribute) memory accesses. High for common memory, Low for attribute memory.
-REG (PC card I/O mode)			Must be Low during I/O cycles when the I/O address is on the bus.
-DMACK (True IDE mode)			The -DMACK input signal is used to acknowledge DMA transfers. It is asserted by the host in response to DMARQ to initiate the transfer. When DMA mode is disabled, the card should ignore the -DMACK signal. If the host does not support DMA mode, but only True IDE mode, this signal should be driven High or tied to V _{CC} by the host.

Table 8. Signals description (continued)

Signal name	Dir.	Pin	Description
RESET (PC card memory mode)	I	41	Resets the card (active High). The card is reset at power-up only if this pin is left High or unconnected.
RESET (PC card I/O mode)			Same as PC card memory mode.
–RESET (True IDE mode)			Hardware reset from the host (active Low).
V _{CC} (PC card memory mode)		13,38	+5 V, +3.3 V power.
V _{CC} (PC card I/O mode)			Same for all modes.
V _{CC} (True IDE mode)			Same for all modes.
–VS1, –VS2 (PC card memory mode)	O	33,40	Voltage sense signals.–VS1 is grounded so that the CIS can be read at 3.3 volts and –VS2 is reserved by PCMCIA for a secondary voltage.
–VS1, –VS2 (PC card I/O mode)			Same for all modes.
–VS1, –VS2 (True IDE mode)			Same for all modes.
–WAIT (PC card memory mode)	O	42	Numonyx CF does not assert the WAIT (IORDY) signal
–WAIT (PC card I/O mode)			
IORDY (True IDE mode - except Ultra DMA mode)			In True IDE mode, except in Ultra DMA mode, this output signal may be used as IORDY.
-DDMARDY (True IDE mode – Ultra DMA Write mode)			In True IDE mode, when Ultra DMA mode DMA Write is active, this signal is asserted by the host to indicate that the device is read to receive Ultra DMA data-in bursts. The device may negate -DDMARDY to pause an Ultra DMA transfer.
DSTROBE (True IDE mode – Ultra DMA Read mode)			In True IDE mode, when Ultra DMA mode DMA Write is active, this signal is the data out strobe generated by the device. Both the rising and falling edge of DSTROBE cause data to be latched by the host. The device may stop generating DSTROBE edges to pause an Ultra DMA data-out burst.

Table 8. Signals description (continued)

Signal name	Dir.	Pin	Description
-WE (PC card memory mode)	I	36	Driven by the host to strobe memory write data to the registers.
-WE (PC card I/O mode)			Used for writing to the configuration registers.
-WE (True IDE mode)			Not used, should be connected to V_{CC} by the host.
WP (PC card memory mode)	O	24	No write protect switch available. It is held Low after the completion of the reset initialization sequence.
-IOIS16 (PC card I/O mode)			Used for the 16-bit port (-IOIS16) function. Low indicates that a 16-bit or odd byte only operation can be performed at the addressed port.
-IOCS16 (True IDE mode)			Asserted Low when the card is expecting a word data transfer cycle.

4.2 Electrical specification

[Table 9](#) defines the DC characteristics for the CompactFlash memory card. Unless otherwise stated, conditions are:

- $V_{CC} = 5\text{ V} \pm 10\%$
- $V_{CC} = 3.3\text{ V} \pm 10\%$
- $-40\text{ }^{\circ}\text{C}$ to $85\text{ }^{\circ}\text{C}$.

[Table 10](#) shows that the card operates correctly in both the voltage ranges and that the current requirements must not exceed the maximum limit shown.

Table 9. Absolute maximum conditions

Parameter	Symbol	Conditions
Input power	V_{CC}	-0.3 V to 6.5 V
Voltage on any pin except V_{CC} with respect to GND	V	-0.5 V to $V_{CC} + 0.5\text{ V}$

Table 10. Input power

Voltage	Maximum average RMS current	Measurement conditions
$3.3\text{ V} \pm 10\%$	75	$-40 + 85\text{ }^{\circ}\text{C}$
$5\text{ V} \pm 10\%$	100	$-40 + 85\text{ }^{\circ}\text{C}$

4.3 Current measurement

The current is measured by connecting an amp meter in series with the V_{CC} supply. The meter should be set to the 2A scale range, and have a fast current probe with an RC filter with a time constant of 0.1 ms. Current measurements are taken while looping on a data transfer command with a sector count of 128. Current consumption values for both read and write commands are not to exceed the maximum average RMS current specified in [Table 10](#). [Table 11](#) shows the input leakage current, [Table 12](#) the input characteristics, [Table 13](#) the output drive type and [Table 14](#) the output drive characteristics.

Table 11. Input leakage current⁽¹⁾

Type	Parameter	Symbol	Conditions	Min	Typ	Max	Units
IxZ	Input leakage current	IL	$V_{IH} = V_{CC}$	- 2		2	μA
			$V_{IL} = \text{GND}$				
IxU	Pull up resistor	RPU1	$V_{CC} = 5.0\text{ V}$	50		500	$\text{k}\Omega$
IxD	Pull down resistor	RPD1	$V_{CC} = 5.0\text{ V}$	50		500	$\text{k}\Omega$

1. x refers to the characteristics described in [Table 12](#). For example, I1U indicates a pull up resistor with a type 1 input characteristic.

Table 12. Input characteristics

Type	Parameter	Symbol	Min	Typ	Max	Min	Typ	Max	Units
			V _{CC} = 3.3 V			V _{CC} = 5.0 V			
1	Input voltage CMOS	V _{IH}	2.4			3.3			V
		V _{IL}			0.6			0.8	
2	Input voltage CMOS	V _{IH}	1.5			2.0			V
		V _{IL}			0.6			0.8	
3	Input voltage CMOS Schmitt Trigger	V _{TH}		1.8			2.8		V
		V _{TL}		1.0			2.0		

Table 13. Output drive type⁽¹⁾

Type	Output type	Valid conditions
OTx	Totem pole	I _{OH} & I _{OL}
OZx	Tri-state N-P channel	I _{OH} & I _{OL}
OPx	P-channel only	I _{OH} only
ONx	N-channel only	I _{OL} only

1. x refers to the characteristics described in [Table 14](#). For example, OT3 refers to totem pole output with a type 3 output drive characteristic.

Table 14. Output drive characteristics

Type	Parameter	Symbol	Conditions	Min	Typ	Max	Units
1	Output voltage	V _{OH}	I _{OH} = -4 mA	V _{CC} - 0.8 V			V
		V _{OL}	I _{OL} = 4 mA			Gnd + 0.4 V	
2	Output voltage	V _{OH}	I _{OH} = -4 mA	V _{CC} - 0.8 V			V
		V _{OL}	I _{OL} = 4 mA			Gnd + 0.4 V	
3	Output voltage	V _{OH}	I _{OH} = -4 mA	V _{CC} - 0.8 V			V
		V _{OL}	I _{OL} = 4 mA			Gnd + 0.4 V	
X	Tri-state leakage current	I _{OZ}	V _{OL} = Gnd		-10	10	μA
			V _{OH} = V _{CC}				

4.4 Additional requirements for CompactFlash advanced timing mode

When operating in a CompactFlash advanced timing mode, the following conditions must be respected:

- Only one CompactFlash card must be connected to the CompactFlash bus
- The load capacitance (cable included) for all signals must be lower than 40 pF
- The cable length must be lower than 0.15 m (6 inches). The cable length is measured from the card connector to the host controller. 0.46 m (18 inches) cables are not supported.

5 Command interface

There are two types of bus cycles and timing sequences that occur in the PCMCIA type interface, direct mapped I/O transfer and memory access. Three types of bus cycles are also available in true IDE interface type: PIO transfer, multi-word DMA transfer and Ultra DMA transfer.

Refer to CF specification 3.0 for details about read and write timing parameters and relative timing diagrams.

In order to set the card mode, the -OE (-ATASEL) signal must be set and kept stable before applying V_{CC} until the reset phase is completed. To place the card in memory mode or I/O mode, -OE(-ATASEL) must be driven High, while it must be driven Low to place the card in true IDE mode.

6 Card configuration

Refer to paragraph 4.4 of CF specification 3.0.

7 Host configuration requirements

The CompactFlash advanced timing modes include PCMCIA-style I/O modes that are faster than the original 250 ns cycle time (see [Section 1: Description](#)).

Before configuring the card interface for the I/O mode, the host must ensure that all the cards connected to a given electrical interface support I/O transfers faster than 250 ns.

These modes must be used in the conditions described in [Section 4.4: Additional requirements for CompactFlash advanced timing mode](#). In particular, the host can be connected to one card only. Consequently, the host must not configure a card to operate in an CompactFlash advanced timing mode if two cards are sharing the same I/O lines in master/slave operation, or if it is connected to the card through a cable which length exceeds 0.15 m.

The load presented to the host by cards supporting Ultra DMA is more controlled than that presented by other CompactFlash cards. Therefore, the use of a card that does not support Ultra DMA in a master/slave arrangement with a Ultra DMA card can affect the critical timing of the Ultra DMA transfers. The host shall not configure a card into Ultra DMA mode when a card not supporting Ultra DMA is also present on the same interface.

When the use of two cards on an interface is otherwise permitted, the host may use any mode that is supported by both cards, but to achieve maximum performance it should use its highest performance mode that is also supported by both cards.

8 Software interface

Refer to section 6.1 of CF specification version 3.0.

9 CF-ATA registers

Refer to section 6.1.5 of CF specification version 3.0.

10 CF-ATA command description

Refer to section 6.2 of CF specification version 3.0.

11 CIS information (typical)

0000: Code 01, link 04
DF 79 01 FF

- Tuple CISTPL_DEVICE (01), length 4 (04)
- Device type is FUNCSPEC
- Extended speed byte used
- Device speed is 80ns
- Write protect switch is not in control
- Device size is 2K bytes

000C: Code 1C, link 05
02 DF 79 01 FF

- Tuple CISTPL_DEVICE_OC (1C), length 5 (05)
- Device conditions: $V_{CC} = 3.3V$
- Device type is FUNCSPEC
- Extended speed byte used
- Device speed is 80ns
- Write protect switch is not in control
- Device size is 2K bytes

001A: Code 18, link 02
DF 01

- Tuple CISTPL_JEDEC_C (18), length 2 (02)
- Device 0 JEDEC id: Manufacturer DF, ID 01

0022: Code 20, link 04
0A 00 00 00

- Tuple CISTPL_MANFID (20), length 4 (04)
- Manufacturer # 0x000A hardware rev 0.00

002E: Code 15, link 12
04 01 53 54 4D 00 53 54 4D 2D x x x x 42 00
00 FF

- Tuple CISTPL_VERS_1 (15), length 18 (12)
- Major version 4, minor version 1
- Product Information: Manufacturer: 'Numonyx',
- Product name: 'Numonyx-xxxxB'

0056: Code 21, link 02
04 01

- Tuple CISTPL_FUNCID (21), length 2 (02)
- Function code 04 (Fixed Disk), system init 01

005E: Code 22, link 02
01 01

- Tuple CISTPL_FUNCE (22), length 2 (02)
- This is a PC Card ATA Disk

0066: Code 22, link 03
02 0C 0F

- Tuple CISTPL_FUNCE (22), length 3 (03)
- V_{PP} is not required
- This is a silicon device
- Identify Drive Model/Serial Number is guaranteed unique
- Low-Power Modes supported: Sleep Standby Idle
- Drive automatically minimizes power
- All modes include 3F7 or 377
- Index bit is not supported
- -IOIS16 is unspecified in Twin configurations

0070: Code 1A, link 05
01 03 00 02 0F

- Tuple CISTPL_CONFIG (1A), length 5 (05)
- Last valid configuration index is 3
- Configuration Register Base Address is 200
- Configuration Registers Present: Configuration Option Register at 200
- Card Configuration and Status Register at 202
- Pin Replacement Register at 204
- Socket and Copy Register at 206

007E: Code 1B, link 08
 C0 C0 A1 01 55 08 00 20

- Tuple CISTPL_CFTABLE_ENTRY (1B), length 8 (08)
- Configuration Table Index is 00 (default)
- Interface type is Memory
- BVDs not active, WP not active, RdyBsy active
- Wait signal support required
- V_{CC} Power Description: Nom V = 5.0 V
- map 2048 bytes of memory to Card address 0
- Miscellaneous Features: Max Twins 0, -Audio, -ReadOnly, +PowerDown

0092: Code 1B, link 06
 00 01 21 B5 1E 4D

- Tuple CISTPL_CFTABLE_ENTRY (1B), length 6 (06)
- Configuration Table Index is 00
- V_{CC} Power Description: Nom V = 3.30 V, Peak I = 45.0 mA

00A2: Code 1B, link 0A
 C1 41 99 01 55 64 F0 FF FF 20

- Tuple CISTPL_CFTABLE_ENTRY (1B), length 10 (0A)
- Configuration Table Index is 01 (default)
- Interface type is I/O
- BVDs not active, WP not active, RdyBsy active
- Wait signal support not required
- V_{CC} Power Description: Nom V = 5.0 V
- Decode 4 I/O lines, bus size 8 or 16
- IRQ may be shared, pulse and level mode interrupts are supported
- Interrupts in mask FFFF are supported
- Miscellaneous Features: Max Twins 0, -Audio, -ReadOnly, +PowerDown

00BA: Code 1B, link 06
 01 01 21 B5 1E 4D

Tuple CISTPL_CFTABLE_ENTRY (1B), length 6 (06)

Configuration Table Index is 01

V_{CC} Power Description: Nom V = 3.30 V,

Peak I = 45.0 mA

00CA: Code 1B, link 0F

C2 41 99 01 55 EA 61 F0 01 07 F6 03 01 EE 20

- Tuple CISTPL_CFTABLE_ENTRY (1B), length 15 (0F)
- Configuration Table Index is 02 (default)
- Interface type is I/O
- BVDs not active, WP not active, RdyBsy active
- Wait signal support not required
- V_{CC} Power Description:
- Nom V = 5.0 V
- Decode 10 I/O lines, bus size 8 or 16
- I/O block at 01F0, length 8
- I/O block at 03F6, length 2
- IRQ may be shared, pulse and level mode interrupts are supported
- Only IRQ14 is supported
- Miscellaneous Features: Max Twins 0, -Audio, -ReadOnly, +PowerDown

00EC: Code 1B, link 06

02 01 21 B5 1E 4D

- Tuple CISTPL_CFTABLE_ENTRY (1B), length 6 (06)
- Configuration Table Index is 02
- V_{CC} Power Description: Nom V = 3.30 V, Peak I = 45.0 mA

00FC: Code 1B, link 0F

C3 41 99 01 55 EA 61 70 01 07 76 03 01 EE 20

- Tuple CISTPL_CFTABLE_ENTRY (1B), length 15 (0F)
- Configuration Table Index is 03 (default)
- Interface type is I/O
- BVDs not active, WP not active, RdyBsy active
- Wait signal support not required
- V_{CC} Power Description: Nom V = 5.0 V
- Decode 10 I/O lines, bus size 8 or 16
- I/O block at 0170, length 8
- I/O block at 0376, length 2
- IRQ may be shared, pulse and level mode interrupts are supported
- Only IRQ14 is supported
- Miscellaneous Features: Max Twins 0, -Audio, -ReadOnly, +PowerDown

011E: Code 1B, link 06
03 01 21 B5 1E 4D

- Tuple CISTPL_CFTABLE_ENTRY (1B), length 6 (06)
- Configuration Table Index is 03
- V_{CC} Power Description: Nom V = 3.30 V, Peak I = 45.0 mA

012E: Code 14, link 00

- Tuple CISTPL_NO_LINK (14), length 0 (00)

0134: Code FF

- Tuple CISTPL_END (FF)

12 Package mechanical

Figure 2. Type I CompactFlash memory card dimensions

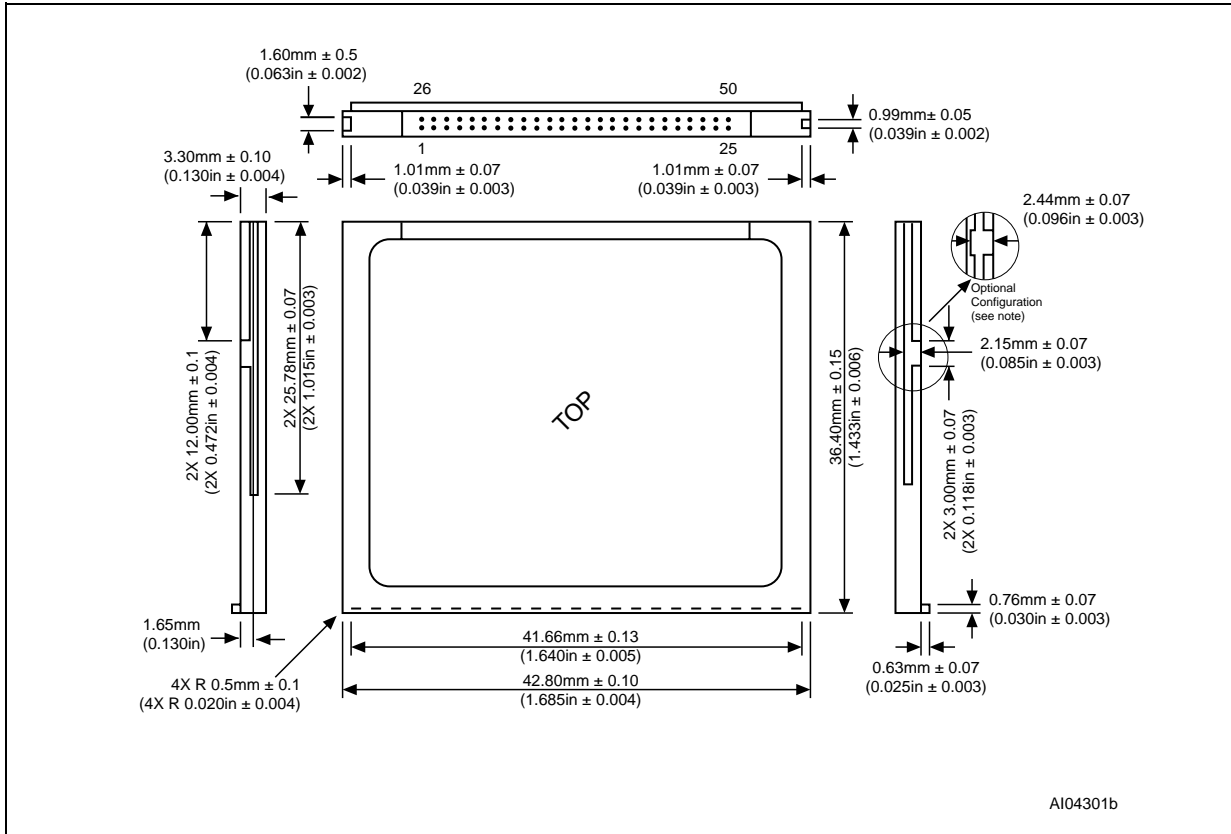

13 Ordering information

Table 15. Ordering information scheme

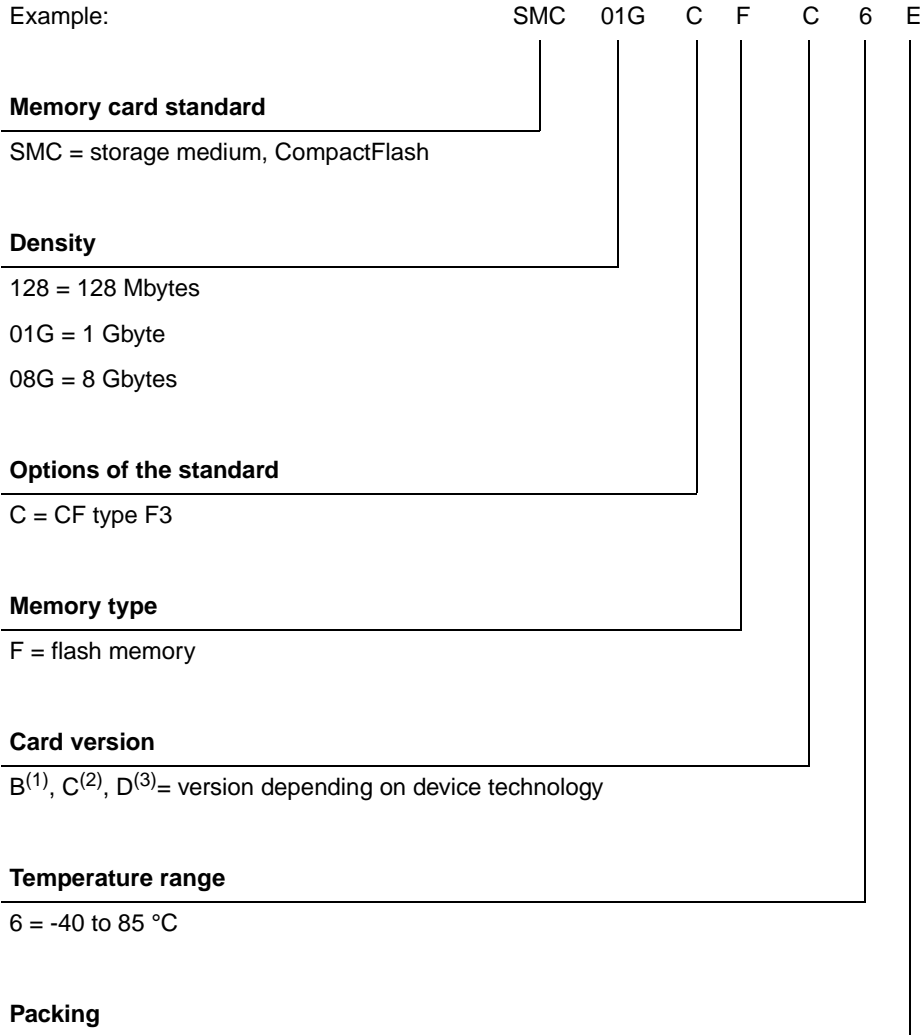

1. Only for 128-Mbyte devices.
2. Only for 1-Gbyte devices.
3. Only for 8-Gbyte devices.

Note: Other digits may be added to the ordering code for pre-programmed parts or other options. Devices are shipped from the factory with the memory content bits erased to '1'. For a list of available products and for further information on any aspect of these devices, please contact your nearest Numonyx sales office.

14 Revision history

Table 16. Document revision history

Date	Revision	Changes
23-Dec-2008	1	Initial release.
12-Mar-2009	2	Document status promoted from target specification to preliminary data. Added SMC128CF root part number throughout the document.
05-May-2009	3	Added references to flash memory power-down logic, flash memory write protect control, and power loss protection on the first page.

Please Read Carefully:

INFORMATION IN THIS DOCUMENT IS PROVIDED IN CONNECTION WITH NUMONYX™ PRODUCTS. NO LICENSE, EXPRESS OR IMPLIED, BY ESTOPPEL OR OTHERWISE, TO ANY INTELLECTUAL PROPERTY RIGHTS IS GRANTED BY THIS DOCUMENT. EXCEPT AS PROVIDED IN NUMONYX'S TERMS AND CONDITIONS OF SALE FOR SUCH PRODUCTS, NUMONYX ASSUMES NO LIABILITY WHATSOEVER, AND NUMONYX DISCLAIMS ANY EXPRESS OR IMPLIED WARRANTY, RELATING TO SALE AND/OR USE OF NUMONYX PRODUCTS INCLUDING LIABILITY OR WARRANTIES RELATING TO FITNESS FOR A PARTICULAR PURPOSE, MERCHANTABILITY, OR INFRINGEMENT OF ANY PATENT, COPYRIGHT OR OTHER INTELLECTUAL PROPERTY RIGHT.

Numonyx products are not intended for use in medical, life saving, life sustaining, critical control or safety systems, or in nuclear facility applications.

Numonyx may make changes to specifications and product descriptions at any time, without notice.

Numonyx, B.V. may have patents or pending patent applications, trademarks, copyrights, or other intellectual property rights that relate to the presented subject matter. The furnishing of documents and other materials and information does not provide any license, express or implied, by estoppel or otherwise, to any such patents, trademarks, copyrights, or other intellectual property rights.

Designers must not rely on the absence or characteristics of any features or instructions marked "reserved" or "undefined." Numonyx reserves these for future definition and shall have no responsibility whatsoever for conflicts or incompatibilities arising from future changes to them.

Contact your local Numonyx sales office or your distributor to obtain the latest specifications and before placing your product order.

Copies of documents which have an order number and are referenced in this document, or other Numonyx literature may be obtained by visiting Numonyx's website at <http://www.numonyx.com>.

Numonyx StrataFlash is a trademark or registered trademark of Numonyx or its subsidiaries in the United States and other countries.

*Other names and brands may be claimed as the property of others.

Copyright © 11/5/7, Numonyx, B.V., All Rights Reserved.

Looking for pricing, stock, or lifecycle information?

Click below to explore more details on WIN SOURCE:

-  [View SMC128CFB6E on WIN SOURCE](#)
-  [Micron Technology Inc. Information](#)

Optimize Your Supply Chain with WIN SOURCE Solutions

-  Global Sourcing Solution
-  Obsolete Management
-  Cost Control Management
-  Shortage Management
-  Alternative Solution
-  Excess Inventory Management