



**THE DATASHEET OF
CY62256LL-55ZXIT**



256K (32K x 8) Static RAM

Features

- **Temperature Ranges**
 - Commercial: 0°C to 70°C
 - Industrial: -40°C to 85°C
 - Automotive: -40°C to 125°C
- **High speed: 55 ns and 70 ns**
- **Voltage range: 4.5V–5.5V operation**
- **Low active power (70 ns, LL version, Com'I and Ind'I)**
 - 275 mW (max.)
- **Low standby power (70 ns, LL version, Com'I and Ind'I)**
 - 28 μW (max.)
- **Easy memory expansion with \overline{CE} and \overline{OE} features**
- **TTL-compatible inputs and outputs**
- **Automatic power-down when deselected**
- **CMOS for optimum speed/power**
- **Package available in a standard 450-mil-wide (300-mil body width) 28-lead narrow SOIC, 28-lead TSOP-1, 28-lead reverse TSOP-1, and 600-mil 28-lead PDIP packages**
- **Also available in Lead-free packages**

Functional Description^[1]

The CY62256 is a high-performance CMOS static RAM organized as 32K words by 8 bits. Easy memory expansion is provided by an active LOW chip enable (\overline{CE}) and active LOW output enable (\overline{OE}) and three-state drivers. This device has an automatic power-down feature, reducing the power consumption by 99.9% when deselected.

An active LOW write enable signal (\overline{WE}) controls the writing/reading operation of the memory. When \overline{CE} and \overline{WE} inputs are both LOW, data on the eight data input/output pins (I/O_0 through I/O_7) is written into the memory location addressed by the address present on the address pins (A_0 through A_{14}). Reading the device is accomplished by selecting the device and enabling the outputs, \overline{CE} and \overline{OE} active LOW, while \overline{WE} remains inactive or HIGH. Under these conditions, the contents of the location addressed by the information on address pins are present on the eight data input/output pins.

The input/output pins remain in a high-impedance state unless the chip is selected, outputs are enabled, and write enable (\overline{WE}) is HIGH.

Logic Block Diagram

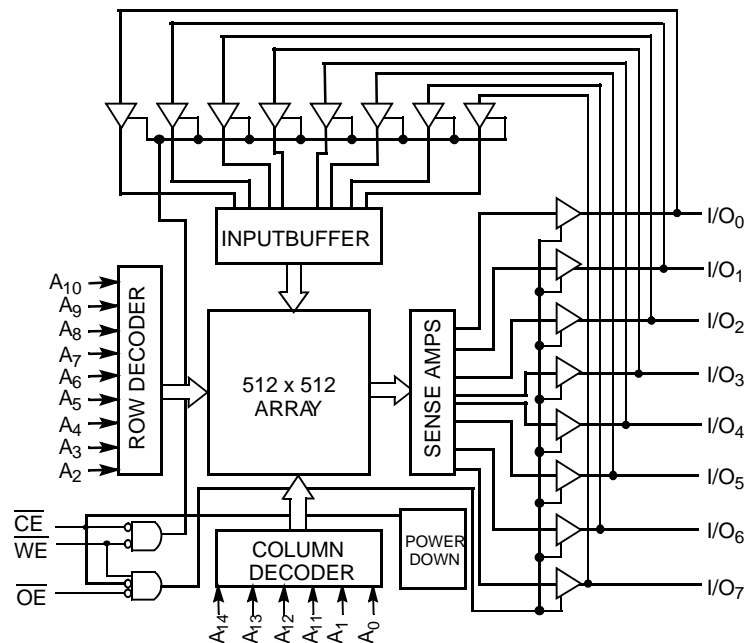

Note:

1. For best practice recommendations, please refer to the Cypress application note "System Design Guidelines" on <http://www.cypress.com>.

Product Portfolio

Product		V _{CC} Range (V)			Speed (ns)	Power Dissipation			
						Operating, I _{CC} (mA)		Standby, I _{SB2} (μA)	
		Min.	Typ. ^[2]	Max.		Typ. ^[2]	Max.	Typ. ^[2]	Max.
CY62256	Commercial	4.5	5.0	5.5	70	28	55	1	5
CY62256L	Com'I / Ind'I				55/70	25	50	2	50
CY62256LL	Commercial				70	25	50	0.1	5
CY62256LL	Industrial				55/70	25	50	0.1	10
CY62256LL	Automotive				55	25	50	0.1	15

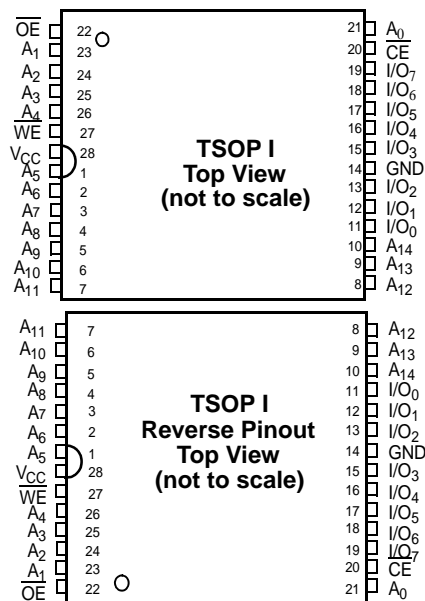
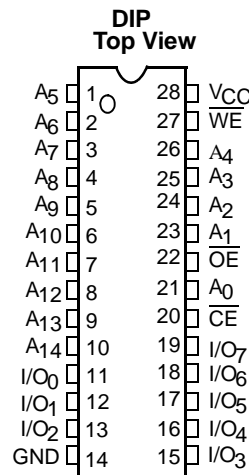
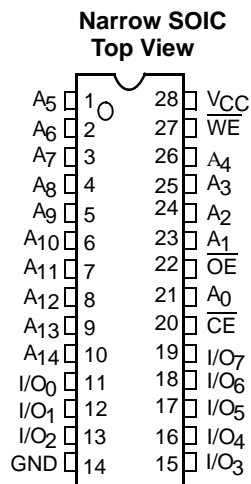
Pin Configurations

Pin Definitions

Pin Number	Type	Description
1–10, 21, 23–26	Input	A₀–A₁₄ . Address Inputs
11–13, 15–19,	Input/Output	I/O₀–I/O₇ . Data lines. Used as input or output lines depending on operation
27	Input/Control	WE . When selected LOW, a WRITE is conducted. When selected HIGH, a READ is conducted
20	Input/Control	CE . When LOW, selects the chip. When HIGH, deselects the chip
22	Input/Control	OE . Output Enable. Controls the direction of the I/O pins. When LOW, the I/O pins behave as outputs. When deasserted HIGH, I/O pins are three-stated, and act as input data pins
14	Ground	GND . Ground for the device
28	Power Supply	V_{CC} . Power supply for the device

Note:

2. Typical specifications are the mean values measured over a large sample size across normal production process variations and are taken at nominal conditions (T_A = 25°C, V_{CC}). Parameters are guaranteed by design and characterization, and not 100% tested.

Maximum Ratings

(Above which the useful life may be impaired. For user guidelines, not tested.)

Storage Temperature -65°C to +150°C
 Ambient Temperature with Power Applied..... -55°C to +125°C
 Supply Voltage to Ground Potential (Pin 28 to Pin 14) -0.5V to +7.0V
 DC Voltage Applied to Outputs in High-Z State^[3] -0.5V to V_{CC} + 0.5V
 DC Input Voltage^[3] -0.5V to V_{CC} + 0.5V

Output Current into Outputs (LOW)..... 20 mA
 Static Discharge Voltage..... > 2001V (per MIL-STD-883, Method 3015)
 Latch-up Current..... > 200 mA

Operating Range

Range	Ambient Temperature (T _A) ^[4]	V _{CC}
Commercial	0°C to +70°C	5V ± 10%
Industrial	-40°C to +85°C	5V ± 10%
Automotive	-40°C to +125°C	5V ± 10%

Electrical Characteristics Over the Operating Range

Parameter	Description	Test Conditions	CY62256-55			CY62256-70			Unit
			Min.	Typ. ^[2]	Max.	Min.	Typ. ^[2]	Max.	
V _{OH}	Output HIGH Voltage	V _{CC} = Min., I _{OH} = -1.0 mA	2.4			2.4			V
V _{OL}	Output LOW Voltage	V _{CC} = Min., I _{OL} = 2.1 mA			0.4			0.4	V
V _{IH}	Input HIGH Voltage		2.2		V _{CC} + 0.5V	2.2		V _{CC} + 0.5V	V
V _{IL}	Input LOW Voltage		-0.5		0.8	-0.5		0.8	V
I _{IX}	Input Leakage Current	GND ≤ V _I ≤ V _{CC}	-0.5		+0.5	-0.5		+0.5	μA
I _{OZ}	Output Leakage Current	GND ≤ V _O ≤ V _{CC} , Output Disabled	-0.5		+0.5	-0.5		+0.5	μA
I _{CC}	V _{CC} Operating Supply Current	V _{CC} = Max., I _{OUT} = 0 mA, f = f _{MAX} = 1/t _{RC}		28	55		28	55	mA
			L	25	50		25	50	mA
			LL	25	50		25	50	mA
I _{SB1}	Automatic CE Power-down Current—TTL Inputs	Max. V _{CC} , CE ≥ V _{IH} , V _{IN} ≥ V _{IH} or V _{IN} ≤ V _{IL} , f = f _{MAX}		0.5	2		0.5	2	mA
			L	0.4	0.6		0.4	0.6	mA
			LL	0.3	0.5		0.3	0.5	mA
I _{SB2}	Automatic CE Power-down Current—CMOS Inputs	Max. V _{CC} , CE ≥ V _{CC} - 0.3V, V _{IN} ≥ V _{CC} - 0.3V, or V _{IN} ≤ 0.3V, f = 0		1	5		1	5	mA
			L	2	50		2	50	μA
			LL	0.1	5		0.1	5	μA
			LL - Ind'l	0.1	10		0.1	10	μA
			LL - Auto	0.1	15				μA

Capacitance^[5]

Parameter	Description	Test Conditions	Max.	Unit
C _{IN}	Input Capacitance	T _A = 25°C, f = 1 MHz, V _{CC} = 5.0V	6	pF
C _{OUT}	Output Capacitance		8	pF

Thermal Resistance

Parameter	Description	Test Conditions	DIP	SOIC	TSOP	RTSOP	Unit
θ _{JA}	Thermal Resistance (Junction to Ambient) ^[5]	Still Air, soldered on a 4.25 x 1.125 inch, 4-layer printed circuit board	75.61	76.56	93.89	93.89	°C/W
θ _{JC}	Thermal Resistance (Junction to Case) ^[5]		43.12	36.07	24.64	24.64	°C/W

Notes:

- V_{IL} (min.) = -2.0V for pulse durations of less than 20 ns.
- T_A is the "Instant-On" case temperature.
- Tested initially and after any design or process changes that may affect these parameters.

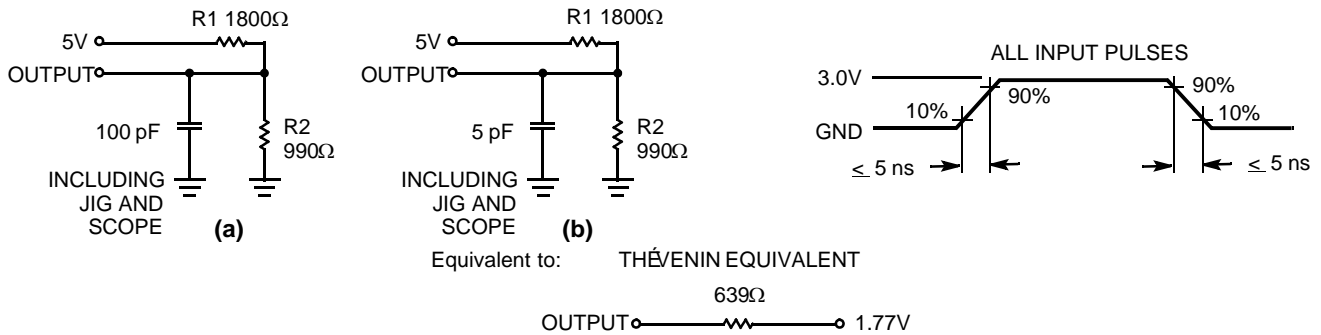
AC Test Loads and Waveforms

Data Retention Characteristics

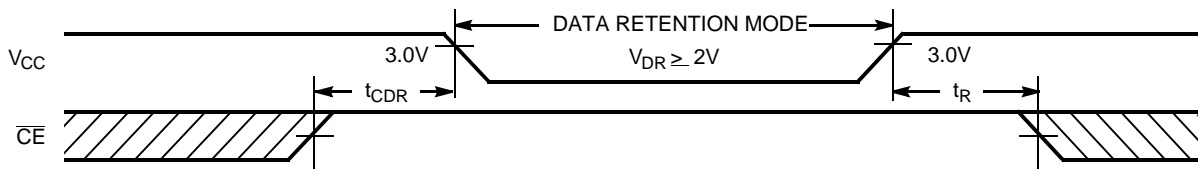
Parameter	Description	Conditions ^[6]	Min.	Typ. ^[2]	Max.	Unit
V_{DR}	V_{CC} for Data Retention		2.0			V
I_{CCDR}	Data Retention Current	L	$V_{CC} = 3.0V, CE \geq V_{CC} - 0.3V,$ $V_{IN} \geq V_{CC} - 0.3V, \text{ or } V_{IN} \leq 0.3V$	2	50	μA
		LL		0.1	5	μA
		LL - Ind'l		0.1	10	μA
		LL - Auto		0.1	10	μA
$t_{CDR}^{[5]}$	Chip Deselect to Data Retention Time		0			ns
$t_R^{[5]}$	Operation Recovery Time		t_{RC}			ns

Data Retention Waveform

Note:

6. No input may exceed $V_{CC} + 0.5V$.

Switching Characteristics Over the Operating Range^[7]

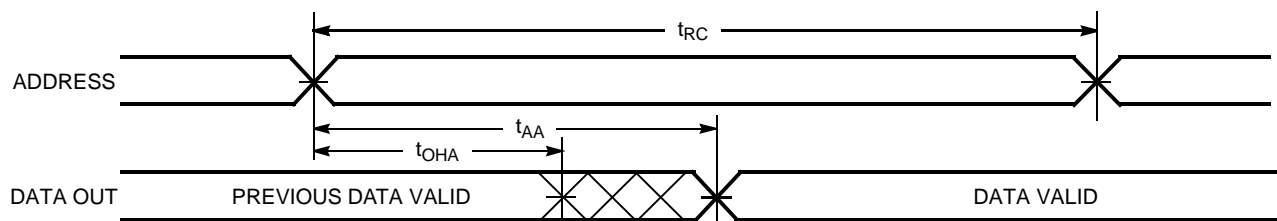
Parameter	Description	CY62256-55		CY62256-70		Unit
		Min.	Max.	Min.	Max.	
Read Cycle						
t_{RC}	Read Cycle Time	55		70		ns
t_{AA}	Address to Data Valid		55		70	ns
t_{OHA}	Data Hold from Address Change	5		5		ns
t_{ACE}	\overline{CE} LOW to Data Valid		55		70	ns
t_{DOE}	\overline{OE} LOW to Data Valid		25		35	ns
t_{LZOE}	\overline{OE} LOW to Low-Z ^[8]	5		5		ns
t_{HZOE}	\overline{OE} HIGH to High-Z ^[8, 9]		20		25	ns
t_{LZCE}	\overline{CE} LOW to Low-Z ^[8]	5		5		ns
t_{HZCE}	\overline{CE} HIGH to High-Z ^[8, 9]		20		25	ns
t_{PU}	\overline{CE} LOW to Power-up	0		0		ns
t_{PD}	\overline{CE} HIGH to Power-down		55		70	ns
Write Cycle^[10, 11]						
t_{WC}	Write Cycle Time	55		70		ns
t_{SCE}	\overline{CE} LOW to Write End	45		60		ns
t_{AW}	Address Set-up to Write End	45		60		ns
t_{HA}	Address Hold from Write End	0		0		ns
t_{SA}	Address Set-up to Write Start	0		0		ns
t_{PWE}	\overline{WE} Pulse Width	40		50		ns
t_{SD}	Data Set-up to Write End	25		30		ns
t_{HD}	Data Hold from Write End	0		0		ns
t_{HZWE}	\overline{WE} LOW to High-Z ^[8, 9]		20		25	ns
t_{LZWE}	\overline{WE} HIGH to Low-Z ^[8]	5		5		ns

Switching Waveforms
Read Cycle No. 1^[12, 13]

Notes:

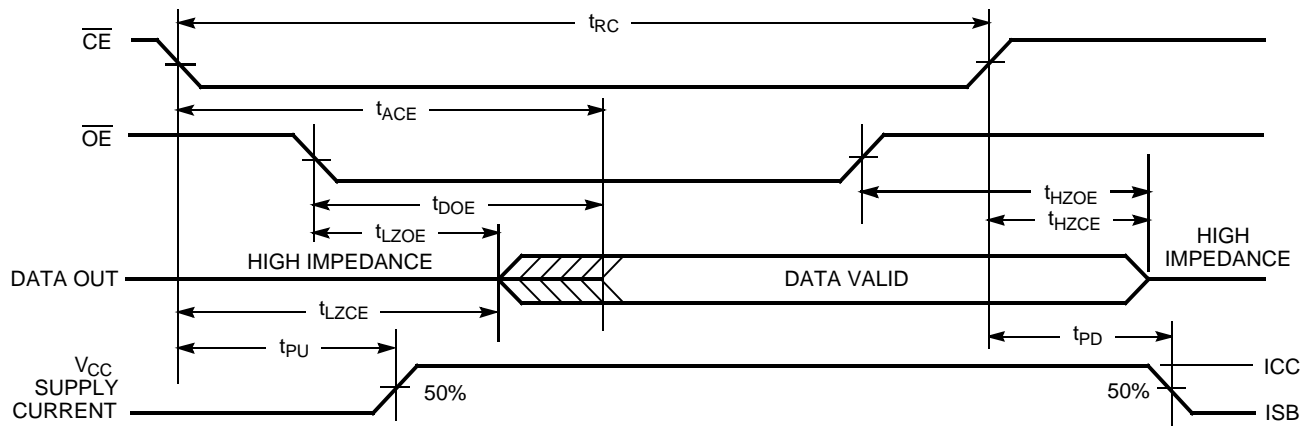
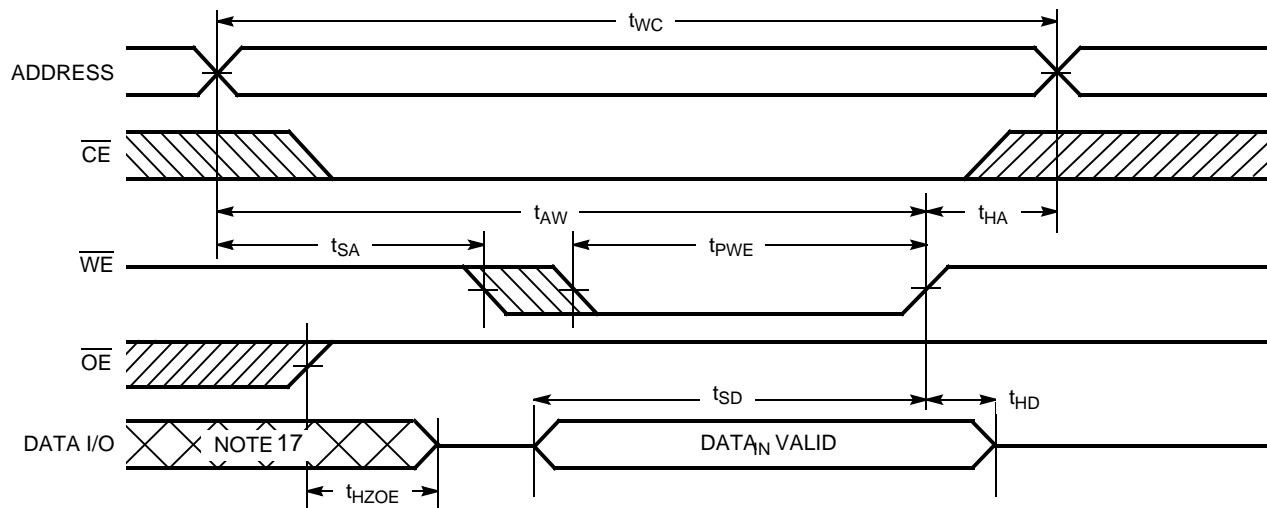
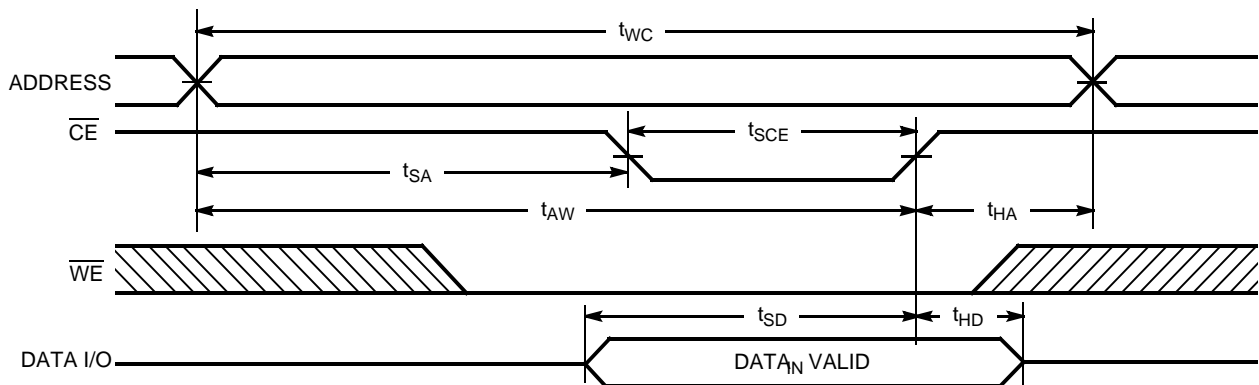
7. Test conditions assume signal transition time of 5 ns or less, timing reference levels of 1.5V, input pulse levels of 0 to 3.0V, and output loading of the specified I_{OL}/I_{OH} and 100-pF load capacitance.
8. At any given temperature and voltage condition, t_{HZCE} is less than t_{LZCE} , t_{HZOE} is less than t_{LZOE} , and t_{HZWE} is less than t_{LZWE} for any given device.
9. t_{HZOE} , t_{HZCE} , and t_{HZWE} are specified with $C_L = 5$ pF as in (b) of AC Test Loads. Transition is measured ± 500 mV from steady-state voltage.
10. The internal Write time of the memory is defined by the overlap of \overline{CE} LOW and \overline{WE} LOW. Both signals must be LOW to initiate a Write and either signal can terminate a Write by going HIGH. The data input set-up and hold timing should be referenced to the rising edge of the signal that terminates the Write.
11. The minimum Write cycle time for Write Cycle #3 (\overline{WE} controlled, \overline{OE} LOW) is the sum of t_{HZWE} and t_{SD} .
12. Device is continuously selected. \overline{OE} , $\overline{CE} = V_{IL}$.
13. \overline{WE} is HIGH for Read cycle.

Switching Waveforms (continued)
Read Cycle No. 2^[13, 14]

Write Cycle No. 1 (WE Controlled)^[10, 15, 16]

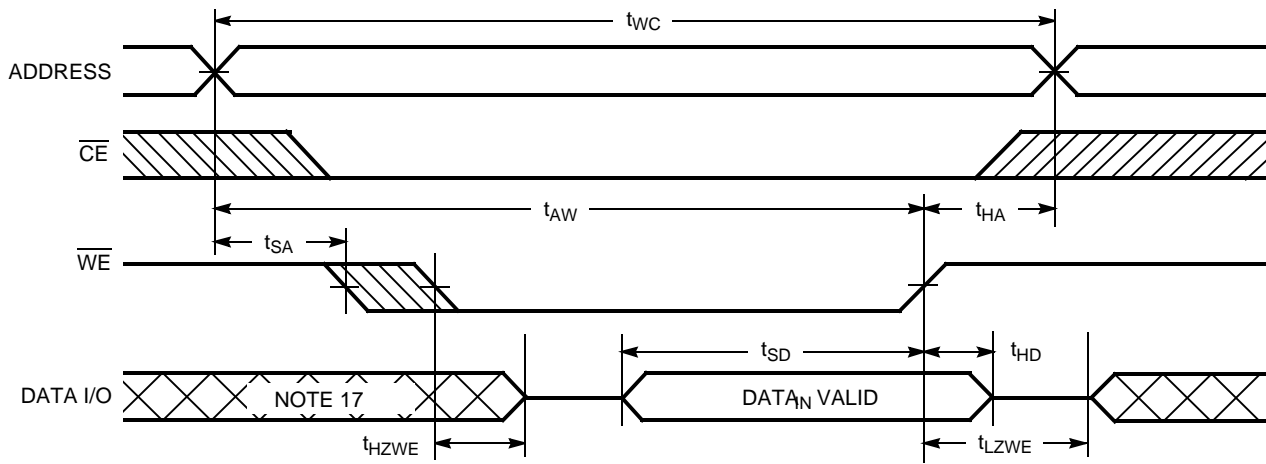
Write Cycle No. 2 (CE Controlled)^[10, 15, 16]

Notes:

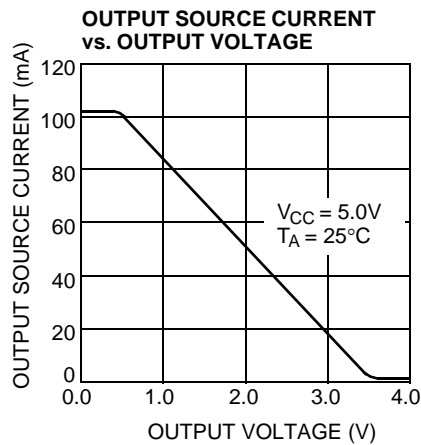
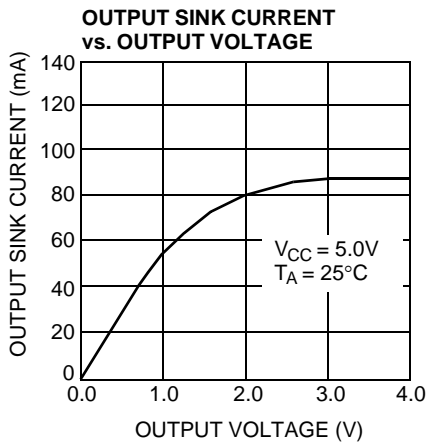
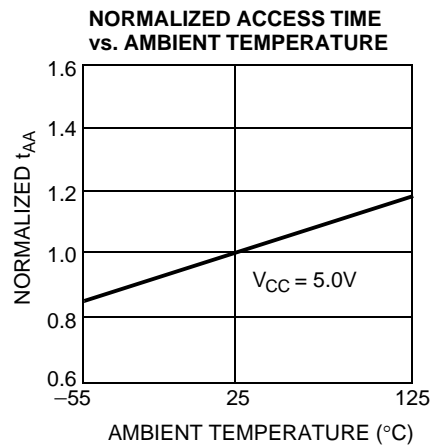
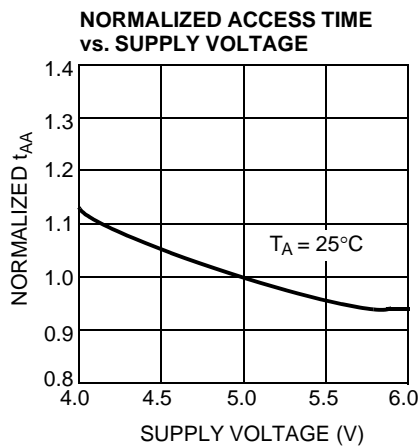
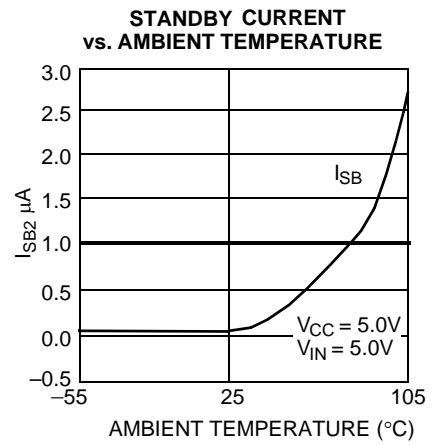
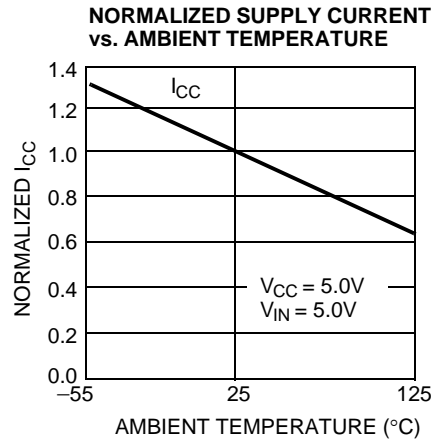
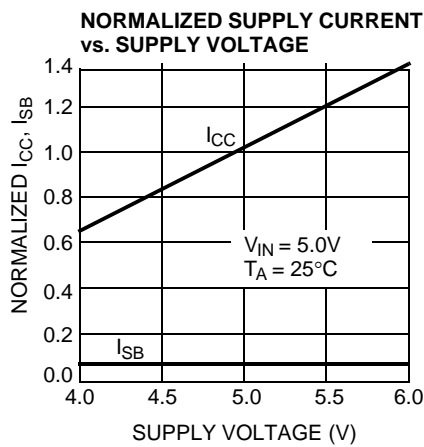
- 14. Address valid prior to or coincident with \overline{CE} transition LOW.
- 15. Data I/O is high impedance if $OE = V_{IH}$.
- 16. If \overline{CE} goes HIGH simultaneously with \overline{WE} HIGH, the output remains in a high-impedance state.
- 17. During this period, the I/Os are in output state and input signals should not be applied.

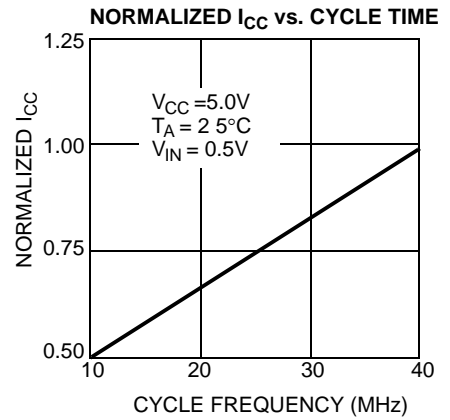
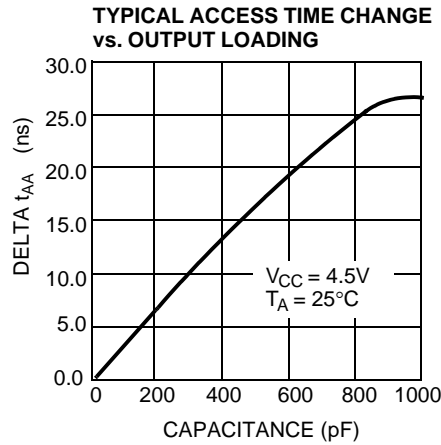
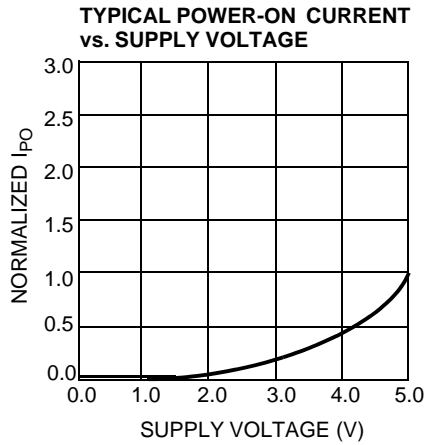
Switching Waveforms (continued)

Write Cycle No. 3 (\overline{WE} Controlled, \overline{OE} LOW)^[11, 16]

Typical DC and AC Characteristics

Typical DC and AC Characteristics (continued)

Truth Table

\overline{CE}	\overline{WE}	\overline{OE}	Inputs/Outputs	Mode	Power
H	X	X	High-Z	Deselect/Power-down	Standby (I_{SB})
L	H	L	Data Out	Read	Active (I_{CC})
L	L	X	Data In	Write	Active (I_{CC})
L	H	H	High-Z	Output Disabled	Active (I_{CC})

Ordering Information

Speed (ns)	Ordering Code	Package Name	Package Type	Operating Range
55	CY62256LL-55SNI	SN28	28-lead (300-Mil Narrow Body) Narrow SOIC	Industrial
	CY62256LL-55SNXI	SN28	28-lead (300-Mil Narrow Body) Narrow SOIC (Pb-Free)	
	CY62256LL-55ZI	Z28	28-lead Thin Small Outline Package	
	CY62256LL-55ZXI	Z28	28-lead Thin Small Outline Package (Pb-Free)	
	CY62256LL-55SNE	SN28	28-lead (300-Mil Narrow Body) Narrow SOIC	Automotive
	CY62256LL-55SNXE	SN28	28-lead (300-Mil Narrow Body) Narrow SOIC (Pb-Free)	
	CY62256LL-55ZE	Z28	28-lead Thin Small Outline Package	
	CY62256LL-55ZXE	Z28	28-lead Thin Small Outline Package (Pb-Free)	
	CY62256LL-55ZRE	ZR28	28-lead Reverse Thin Small Outline Package	
	CY62256LL-55ZRXE	ZR28	28-lead Reverse Thin Small Outline Package (Pb-Free)	
70	CY62256-70SNC	SN28	28-lead (300-Mil Narrow Body) Narrow SOIC	Commercial
	CY62256L-70SNC	SN28	28-lead (300-Mil Narrow Body) Narrow SOIC	
	CY62256L-70SNXC	SN28	28-lead (300-Mil Narrow Body) Narrow SOIC (Pb-Free)	
	CY62256LL-70SNC	SN28	28-lead (300-Mil Narrow Body) Narrow SOIC	
	CY62256LL-70SNXC	SN28	28-lead (300-Mil Narrow Body) Narrow SOIC (Pb-Free)	
	CY62256L-70SNI	SN28	28-lead (300-Mil Narrow Body) Narrow SOIC	Industrial
	CY62256L-70SNXI	SN28	28-lead (300-Mil Narrow Body) Narrow SOIC (Pb-Free)	
	CY62256LL-70SNI	SN28	28-lead (300-Mil Narrow Body) Narrow SOIC	
	CY62256LL-70SNXI	SN28	28-lead (300-Mil Narrow Body) Narrow SOIC (Pb-Free)	
	CY62256LL-70ZC	Z28	28-lead Thin Small Outline Package	Commercial
	CY62256LL-70ZXC	Z28	28-lead Thin Small Outline Package (Pb-Free)	
	CY62256LL-70ZI	Z28	28-lead Thin Small Outline Package	Industrial
	CY62256LL-70ZXI	Z28	28-lead Thin Small Outline Package (Pb-Free)	
	CY62256-70PC	P15	28-lead (600-Mil) Molded DIP	Commercial
	CY62256L-70PC	P15	28-lead (600-Mil) Molded DIP	
	CY62256L-70PXC	P15	28-lead (600-Mil) Molded DIP (Pb-Free)	
	CY62256LL-70PC	P15	28-lead (600-Mil) Molded DIP	
	CY62256LL-70PXC	P15	28-lead (600-Mil) Molded DIP (Pb-Free)	
	CY62256LL-70ZRI	ZR28	28-lead Reverse Thin Small Outline Package	Industrial
	CY62256LL-70ZRXI	ZR28	28-lead Reverse Thin Small Outline Package (Pb-Free)	

Package Diagrams

28-lead (600-mil) Molded DIP P15

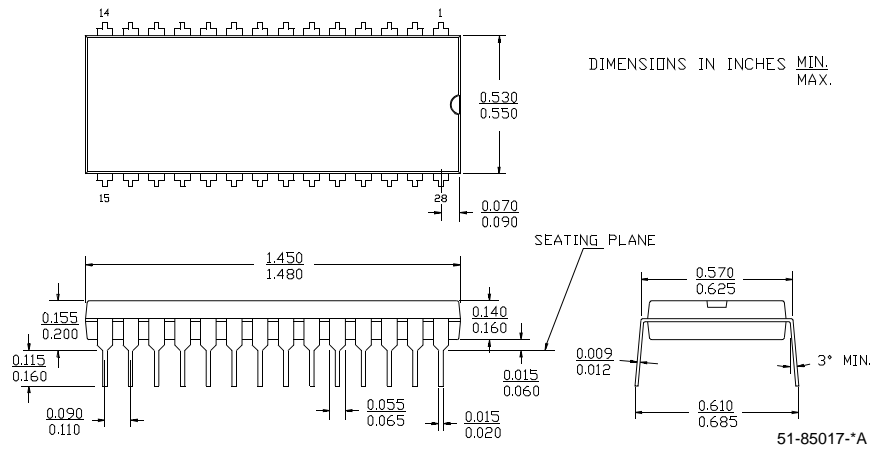

28-lead (300-mil) SNC (Narrow Body) SN28

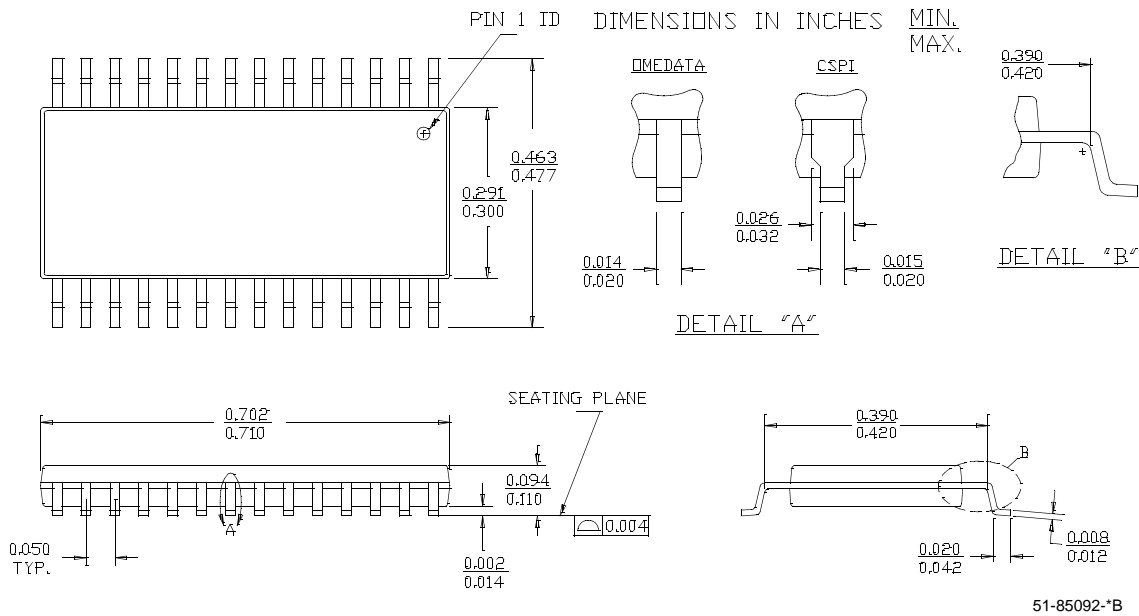

Package Diagrams (continued)

28-lead Thin Small Outline Package Type 1 (8 x 13.4 mm) Z28

NOTE: ORIENTATION I.D. MAY BE LOCATED EITHER AS SHOWN IN OPTION 1 OR OPTION 2

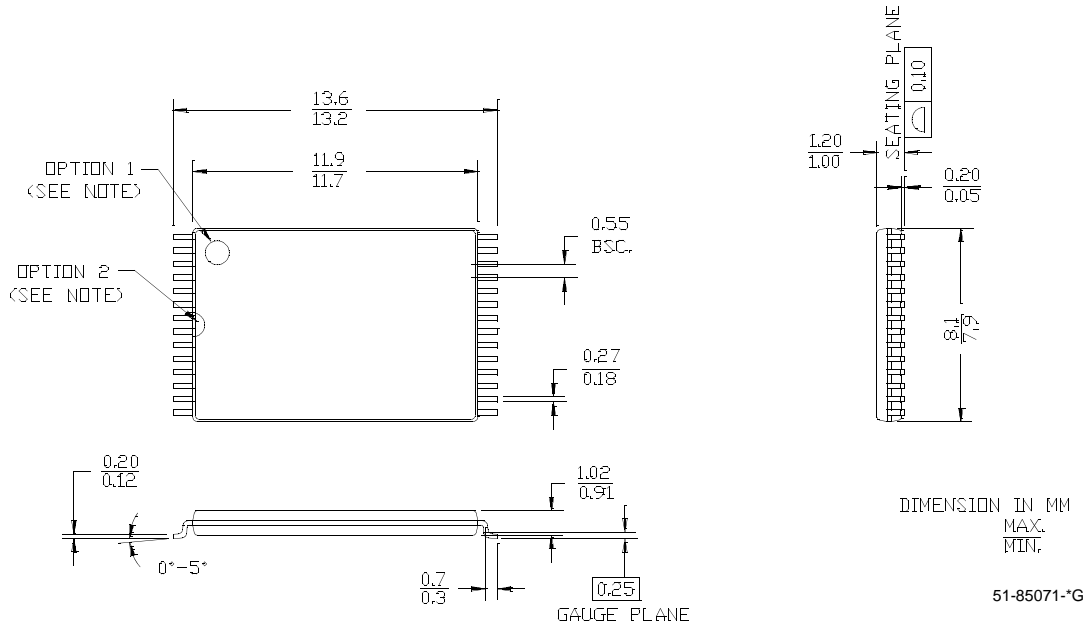

28-Lead Reverse Type 1 Thin Small Outline Package (8x13.4 mm) ZR28

NOTE: ORIENTATION I.D. MAY BE LOCATED EITHER AS SHOWN IN OPTION 1 OR OPTION 2

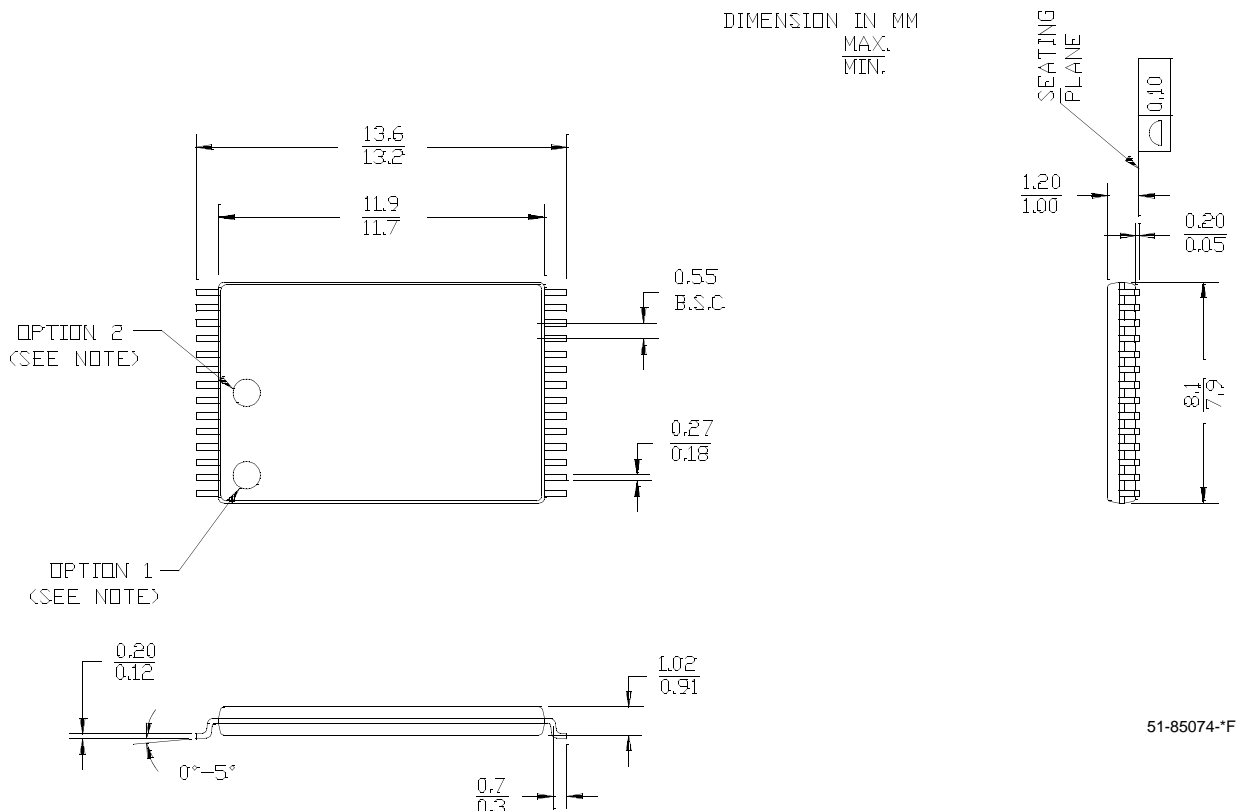



All product and company names mentioned in this document are the trademarks of their respective holders.

Document History Page

Document Title: CY62256 256K (32K x 8) Static RAM Document Number: 38-05248				
REV.	ECN NO.	Issue Date	Orig. of Change	Description of Change
**	113454	03/06/02	MGN	Change from Spec number: 38-00455 to 38-05248 Remove obsolete parts from ordering info, standardize format
*A	115227	05/23/02	GBI	Changed SN Package Diagram
*B	116506	09/04/02	GBI	Added footnote 1. Corrected package description in Ordering Information table
*C	238448	See ECN	AJU	Added Automotive product information
*D	344595	See ECN	SYT	Added Pb-Free packages on page# 10
*E	395936	See ECN	SYT	Changed address of Cypress Semiconductor Corporation on Page# 1 from "3901 North First Street" to "198 Champion Court" Added CY62256L-70SNXI package in the Ordering Information on Page # 10

Looking for pricing, stock, or lifecycle information?

Click below to explore more details on WIN SOURCE:

-  [View CY62256LL-55ZXIT on WIN SOURCE](#)
-  [Cypress Semiconductor Corp Information](#)

Optimize Your Supply Chain with WIN SOURCE Solutions

-  Global Sourcing Solution
-  Obsolete Management
-  Cost Control Management
-  Shortage Management
-  Alternative Solution
-  Excess Inventory Management