



**THE DATASHEET OF
LT8304ES8E#PBF**



100V_{IN} Micropower No-Opto Isolated Flyback Converter with 150V/2A Switch

FEATURES

- 3V to 100V Input Voltage Range
- 2A, 150V Internal DMOS Power Switch
- Low Quiescent Current:
 - 116µA in Sleep Mode
 - 390µA in Active Mode
- Quasi-Resonant Boundary Mode Operation at Heavy Load
- Low Ripple Burst Mode® Operation at Light Load
- Minimum Load < 0.5% (Typ) of Full Output
- No Transformer Third Winding or Opto-Isolator Required for Output Voltage Regulation
- Accurate EN/UVLO Threshold and Hysteresis
- Internal Compensation and Soft-Start
- Temperature Compensation for Output Diode
- Output Short-Circuit Protection
- Thermally Enhanced 8-Lead SO Package

APPLICATIONS

- Isolated Automotive, Industrial, Medical, Telecom Power Supplies
- Isolated Auxiliary/Housekeeping Power Supplies

DESCRIPTION

The **LT®8304/LT8304-1** are monolithic micropower isolated flyback converters. By sampling the isolated output voltage directly from the primary-side flyback waveform, the parts require no third winding or opto-isolator for regulation. The output voltage is programmed with two external resistors and a third optional temperature compensation resistor. Boundary mode operation provides a small magnetic solution with excellent load regulation. Low ripple Burst Mode operation maintains high efficiency at light load while minimizing the output voltage ripple. A 2A, 150V DMOS power switch is integrated along with all the high voltage circuitry and control logic into a thermally enhanced 8-lead SO package.

The LT8304/LT8304-1 operate from an input voltage range of 3V to 100V and deliver up to 24W of isolated output power. The high level of integration and the use of boundary and low ripple Burst Mode operation result in a simple to use, low component count, and high efficiency application solution for isolated power delivery. The LT8304-1 is specially optimized for high step-up output applications.

LT, LT, LTC, LTM, Linear Technology, the Linear logo and Burst Mode are registered trademarks of Linear Technology Corporation. All other trademarks are the property of their respective owners. Protected by U.S. Patents, including 5438499, 7463497, 7471522.

TYPICAL APPLICATION

4V to 80V_{IN}/5V_{OUT} Isolated Flyback Converter

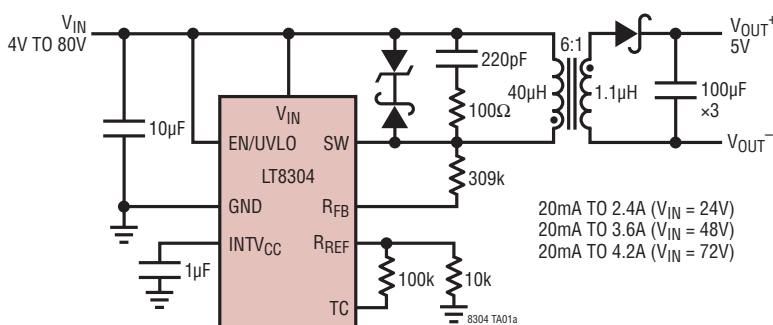

Efficiency vs Load Current

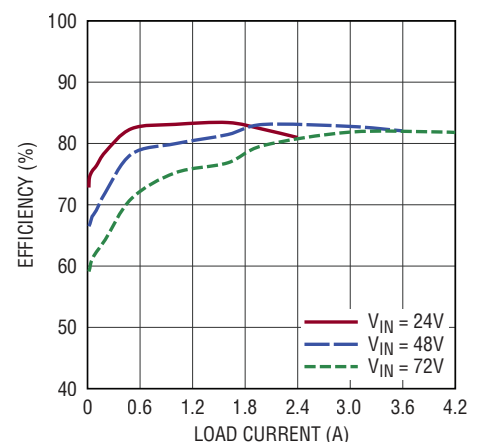

8304 TA01b

LT8304/LT8304-1

ABSOLUTE MAXIMUM RATINGS

(Note 1)

SW (Note 2)	150V
V_{IN}	100V
EN/UVLO	V_{IN}
R_{FB}	$V_{IN} - 0.5V$ to V_{IN}
Current Into R_{FB}	200 μ A
INTV _{CC} , R _{REF} , TC	4V
Operating Junction Temperature T _J Range (Notes 3, 4)	
LT8304E/LT8304E-1	-40°C to 125°C
LT8304I/LT8304I-1	-40°C to 125°C
LT8304H/LT8304H-1	-40°C to 150°C
Storage Temperature Range	-65°C to 150°C
Lead Temperature (Soldering, 10 sec)	300°C

PIN CONFIGURATION

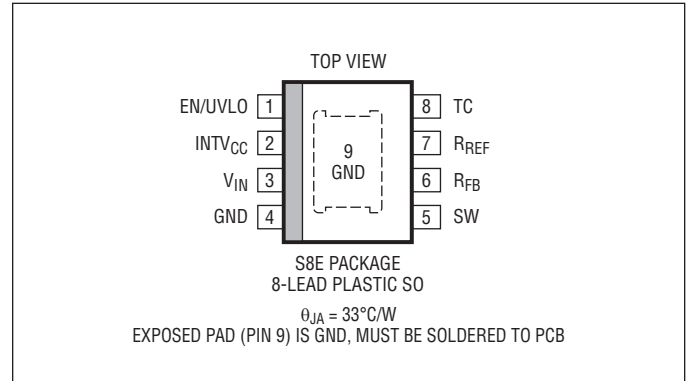

ORDER INFORMATION <http://www.linear.com/product/LT8304#orderinfo>

LEAD FREE FINISH	TAPE AND REEL	PART MARKING*	PACKAGE DESCRIPTION	TEMPERATURE RANGE
LT8304ES8E#PBF	LT8304ES8E#TRPBF	8304	8-Lead Plastic SO	-40°C to 125°C
LT8304IS8E#PBF	LT8304IS8E#TRPBF	8304	8-Lead Plastic SO	-40°C to 125°C
LT8304HS8E#PBF	LT8304HS8E#TRPBF	8304	8-Lead Plastic SO	-40°C to 150°C
LT8304ES8E-1#PBF	LT8304ES8E-1#TRPBF	83041	8-Lead Plastic SO	-40°C to 125°C
LT8304IS8E-1#PBF	LT8304IS8E-1#TRPBF	83041	8-Lead Plastic SO	-40°C to 125°C
LT8304HS8E-1#PBF	LT8304HS8E-1#TRPBF	83041	8-Lead Plastic SO	-40°C to 150°C

Consult LTC Marketing for parts specified with wider operating temperature ranges. *The temperature grade is identified by a label on the shipping container

For more information on lead free part marking, go to: <http://www.linear.com/leadfree/>

For more information on tape and reel specifications, go to: <http://www.linear.com/tapeandreeel/>. Some packages are available in 500 unit reels through designated sales channels with #TRMPBF suffix.

ELECTRICAL CHARACTERISTICS The ● denotes the specifications which apply over the full operating temperature range, otherwise specifications are at $T_A = 25^\circ\text{C}$. $V_{IN} = 24\text{V}$, $V_{EN/UVLO} = V_{IN}$, $C_{INTVCC} = 1\mu\text{F}$ to GND, unless otherwise noted.

SYMBOL	PARAMETER	CONDITIONS	MIN	TYP	MAX	UNIT	
V_{IN}	V_{IN} Voltage Range	●	3		100	V	
I_Q	V_{IN} Quiescent Current	$V_{EN/UVLO} = 0.2\text{V}$		1.8	3	μA	
		$V_{EN/UVLO} = 1.1\text{V}$		63		μA	
		Sleep Mode (Switch Off)		116		μA	
		Active Mode (Switch On)		390		μA	
	EN/UVLO Shutdown Threshold	For Lowest Off I_Q	●	0.2	0.5	V	
	EN/UVLO Enable Threshold	Falling	●	1.178	1.214	1.250	V
	EN/UVLO Enable Hysteresis			14		mV	
I_{HYS}	EN/UVLO Hysteresis Current	$V_{EN/UVLO} = 0.2\text{V}$	-0.1	0	0.1	μA	
		$V_{EN/UVLO} = 1.1\text{V}$	2.3	2.5	2.7	μA	
		$V_{EN/UVLO} = 1.3\text{V}$	-0.1	0	0.1	μA	
V_{INTVCC}	INTV _{CC} Regulation Voltage	$I_{INTVCC} = 0\text{mA}$ to 10mA	2.8	3	3.1	V	
I_{INTVCC}	INTV _{CC} Current Limit	$V_{INTVCC} = 2.8\text{V}$		16		mA	
	INTV _{CC} UVLO Threshold	Falling	2.38	2.47	2.56	V	
	INTV _{CC} UVLO Hysteresis			105		mV	
	($R_{FB} - V_{IN}$) Voltage	$I_{RFB} = 75\mu\text{A}$ to $125\mu\text{A}$	-60		60	mV	
	R_{REF} Regulation Voltage	●	0.98	1.00	1.02	V	
	R_{REF} Regulation Voltage Line Regulation	$3\text{V} \leq V_{IN} \leq 100\text{V}$		0.02	0.1	%	
V_{TC}	TC Pin Voltage			1.00		V	
I_{TC}	TC Pin Current	$V_{TC} = 1.2\text{V}$ (LT8304)	12	15	18	μA	
		$V_{TC} = 1.2\text{V}$ (LT8304-1)	7	10	13	μA	
		$V_{TC} = 0.8\text{V}$		-200		μA	
f_{MAX}	Maximum Switching Frequency	●	315	350	385	kHz	
f_{MIN}	Minimum Switching Frequency		8	11	14	kHz	
$t_{ON(MIN)}$	Minimum Switch-On Time	(LT8304)		160		ns	
		(LT8304-1)		950		ns	
$I_{SW(MAX)}$	Maximum Switch Current Limit		2.0	2.4	2.8	A	
$I_{SW(MIN)}$	Minimum Switch Current Limit		0.43	0.48	0.53	A	
$R_{DS(ON)}$	Switch On-Resistance	$I_{SW} = 0.8\text{A}$		0.5		Ω	
I_{LKG}	Switch Leakage Current	$V_{SW} = 150\text{V}$		0.1	0.5	μA	
t_{SS}	Soft-Start Timer			11		ms	

Note 1: Stresses beyond those listed under Absolute Maximum Ratings may cause permanent damage to the device. Exposure to any Absolute Maximum Rating condition for extended periods may affect device reliability and lifetime.

Note 2: The SW pin is rated to 150V for transients. Depending on the leakage inductance voltage spike, operating waveforms of the SW pin should be derated to keep the flyback voltage spike below 150V as shown in Figure 5.

Note 3: The LT8304E/LT8304E-1 are guaranteed to meet performance specifications from 0°C to 125°C junction temperature. Specifications over the -40°C to 125°C operating junction temperature range are assured by design, characterization and correlation with statistical process controls.

The LT8304I/LT8304I-1 are guaranteed over the full -40°C to 125°C operating junction temperature range. LT8304H/LT304H-1 are guaranteed over the full -40°C to 150°C operating junction temperature range. High junction temperatures degrade operating lifetimes. Operating lifetime is derated at junction temperature greater than 125°C .

Note 4: The LT8304/LT8304-1 includes overtemperature protection that is intended to protect the device during momentary overload conditions. Junction temperature will exceed 150°C when overtemperature protection is active. Continuous operation above the specified maximum operating junction temperature may impair device reliability.

TYPICAL PERFORMANCE CHARACTERISTICS $T_A = 25^\circ\text{C}$, unless otherwise noted.

Output Load and Line Regulation

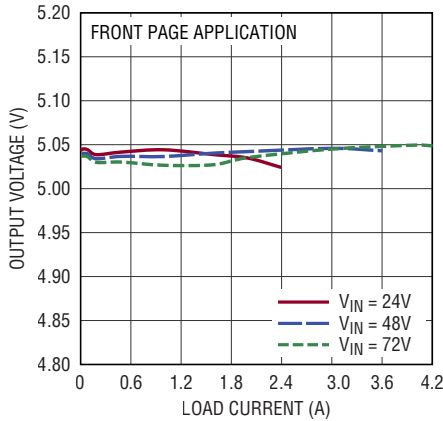

Output Temperature Variation

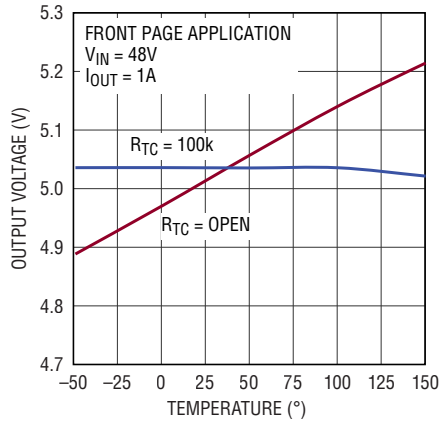

Switching Frequency vs Load Current

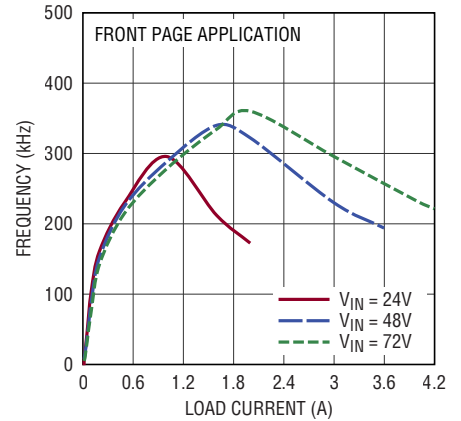

Boundary Mode Waveforms

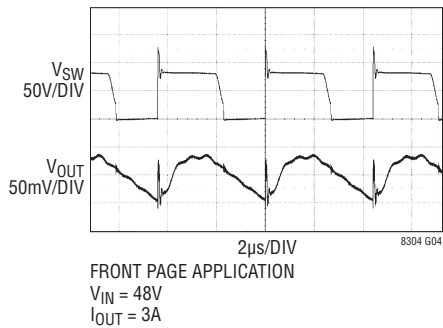

Discontinuous Mode Waveforms

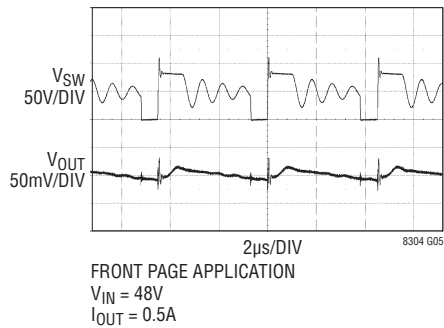

Burst Mode Operation Waveforms

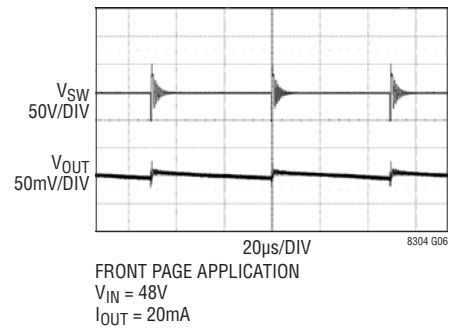

V_{IN} Shutdown Current

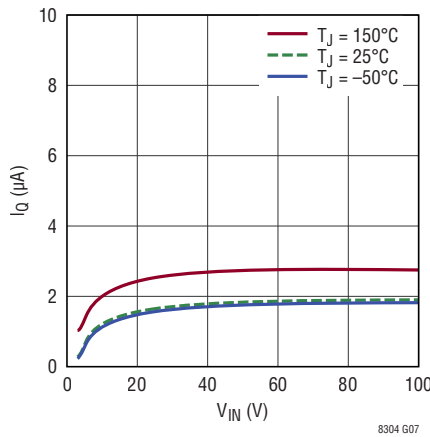

V_{IN} Quiescent Current, Sleep Mode

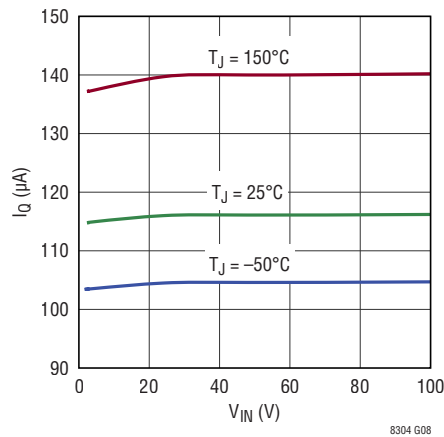

V_{IN} Quiescent Current, Active Mode

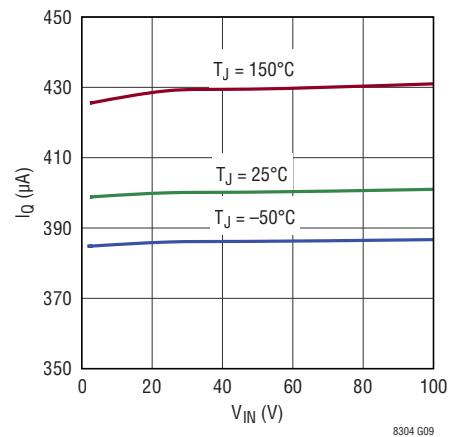

TYPICAL PERFORMANCE CHARACTERISTICS $T_A = 25^\circ\text{C}$, unless otherwise noted.

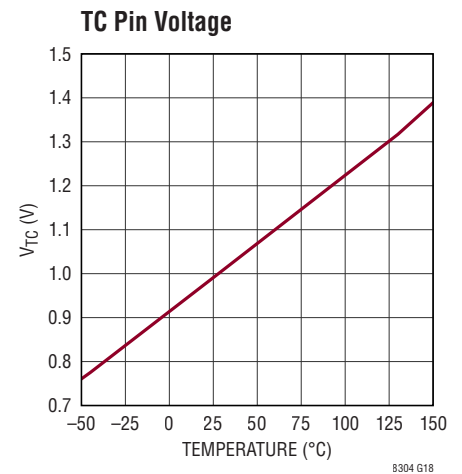
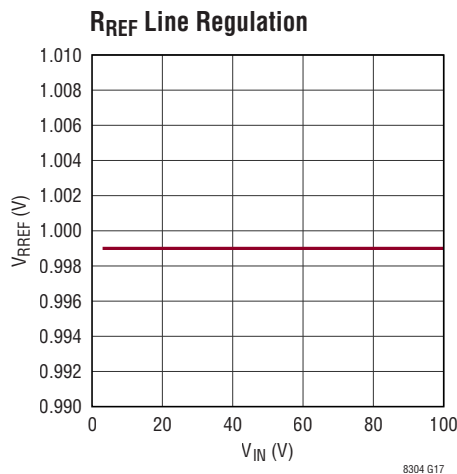
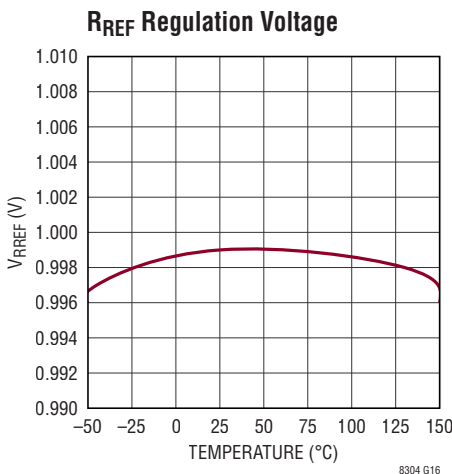
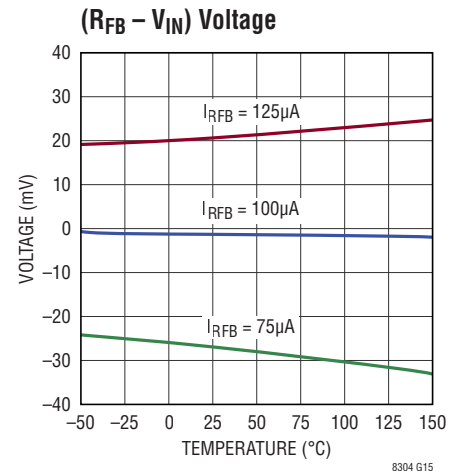
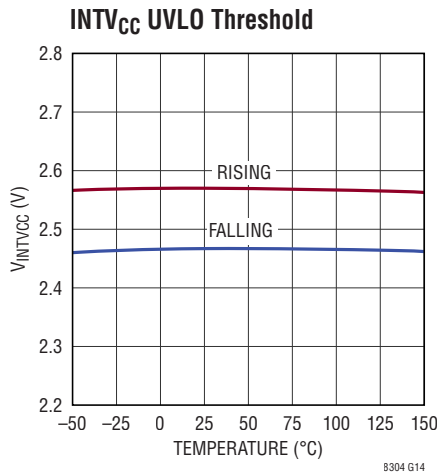
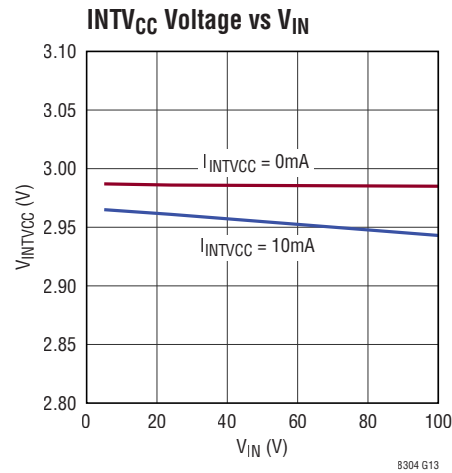
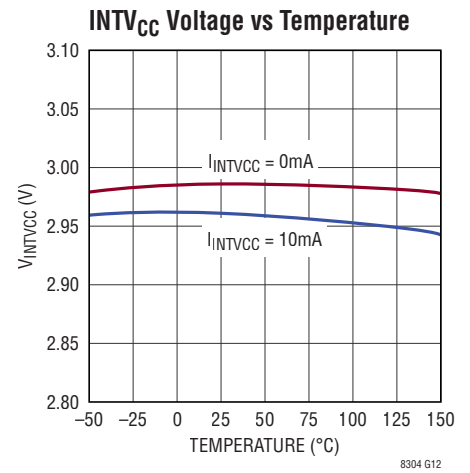
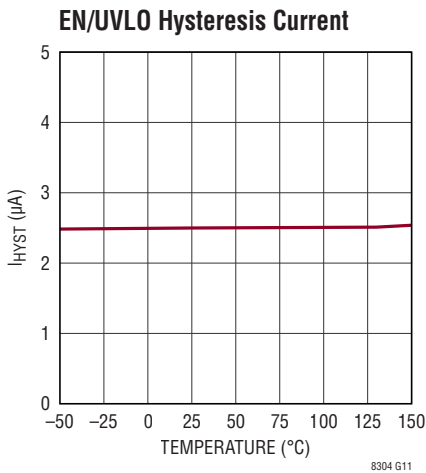
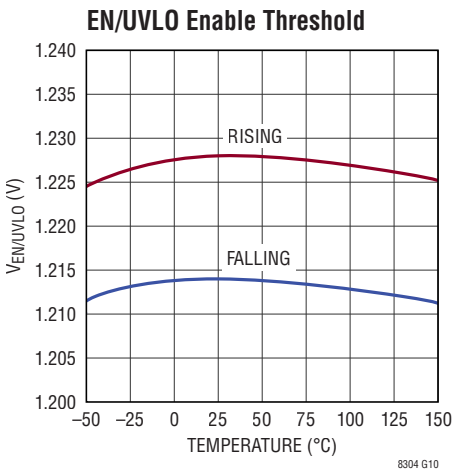

TYPICAL PERFORMANCE CHARACTERISTICS $T_A = 25^\circ\text{C}$, unless otherwise noted.

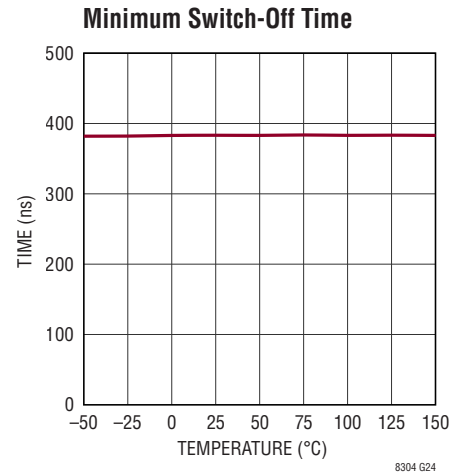
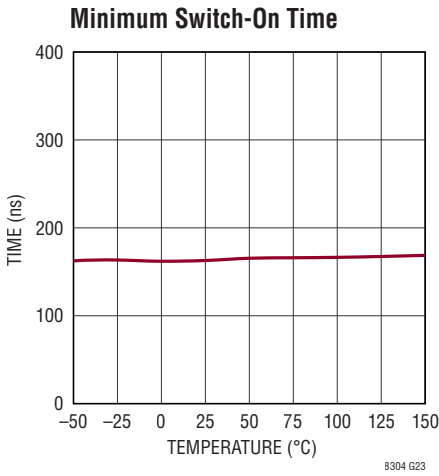
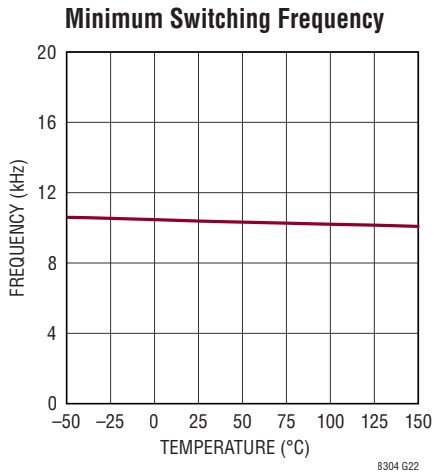
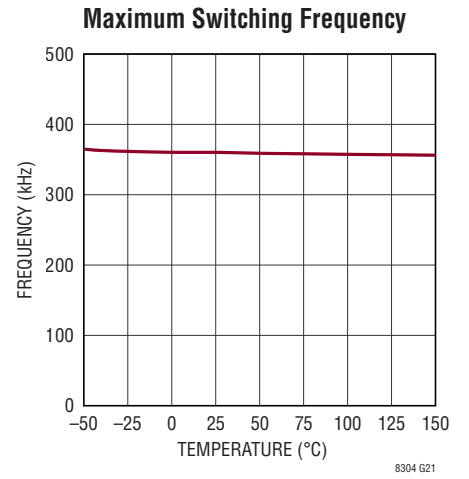
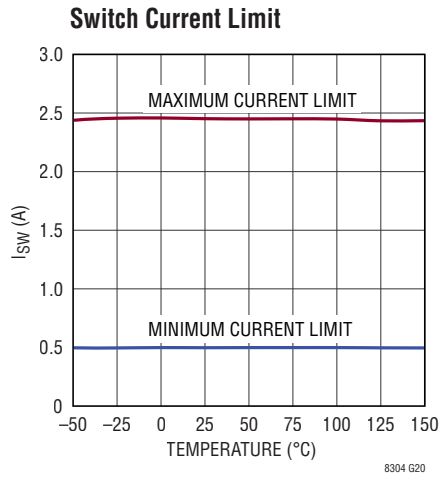
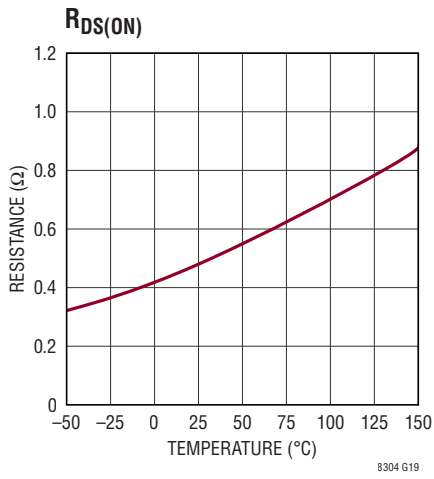

PIN FUNCTIONS

EN/UVLO (Pin 1): Enable/Undervoltage Lockout. The EN/UVLO pin is used to enable the LT8304. Pull the pin below 0.2V to shut down the LT8304. This pin has an accurate 1.214V threshold and can be used to program a V_{IN} undervoltage lockout (UVLO) threshold using a resistor divider from V_{IN} to ground. A 2.5 μ A current hysteresis allows the programming of V_{IN} UVLO hysteresis. If neither function is used, tie this pin directly to V_{IN} .

INTV_{CC} (Pin 2): Internal 3V Linear Regulator Output. The INTV_{CC} pin is supplied from V_{IN} and powers the internal control circuitry and gate driver. Do not overdrive the INTV_{CC} pin with any external supply, such as a third winding supply. Locally bypass this pin to ground with a minimum 1 μ F ceramic capacitor.

V_{IN} (Pin 3): Input Supply. The V_{IN} pin supplies current to the internal circuitry and serves as a reference voltage for the feedback circuitry connected to the R_{FB} pin. Locally bypass this pin to ground with a capacitor.

GND (Pin 4, Exposed Pad Pin 9): Ground. The exposed pad provides both electrical contact to ground and good thermal contact to the printed circuit board. Solder the exposed pad directly to the ground plane.

SW (Pin 5): Drain of the Internal DMOS Power Switch. Minimize trace area at this pin to reduce EMI and voltage spikes.

R_{FB} (Pin 6): Input Pin for External Feedback Resistor. Connect a resistor from this pin to the transformer primary SW pin. The ratio of the R_{FB} resistor to the R_{REF} resistor, times the internal voltage reference, determines the output voltage (plus the effect of any non-unity transformer turns ratio). Minimize trace area at this pin.

R_{REF} (Pin 7): Input Pin for External Ground Referred Reference Resistor. The resistor at this pin should be in the range of 10k, but for convenience in selecting a resistor divider ratio, the value may range from 9.09k to 11.0k.

TC (Pin 8): Output Voltage Temperature Compensation. The voltage at this pin is proportional to absolute temperature (PTAT) with temperature coefficient equal to 3.35mV/°C, i.e., equal to 1V at room temperature 25°C. The TC pin voltage can be used to estimate the LT8304 junction temperature. Connect a resistor from this pin to the R_{REF} pin to compensate the output diode temperature coefficient.

BLOCK DIAGRAM

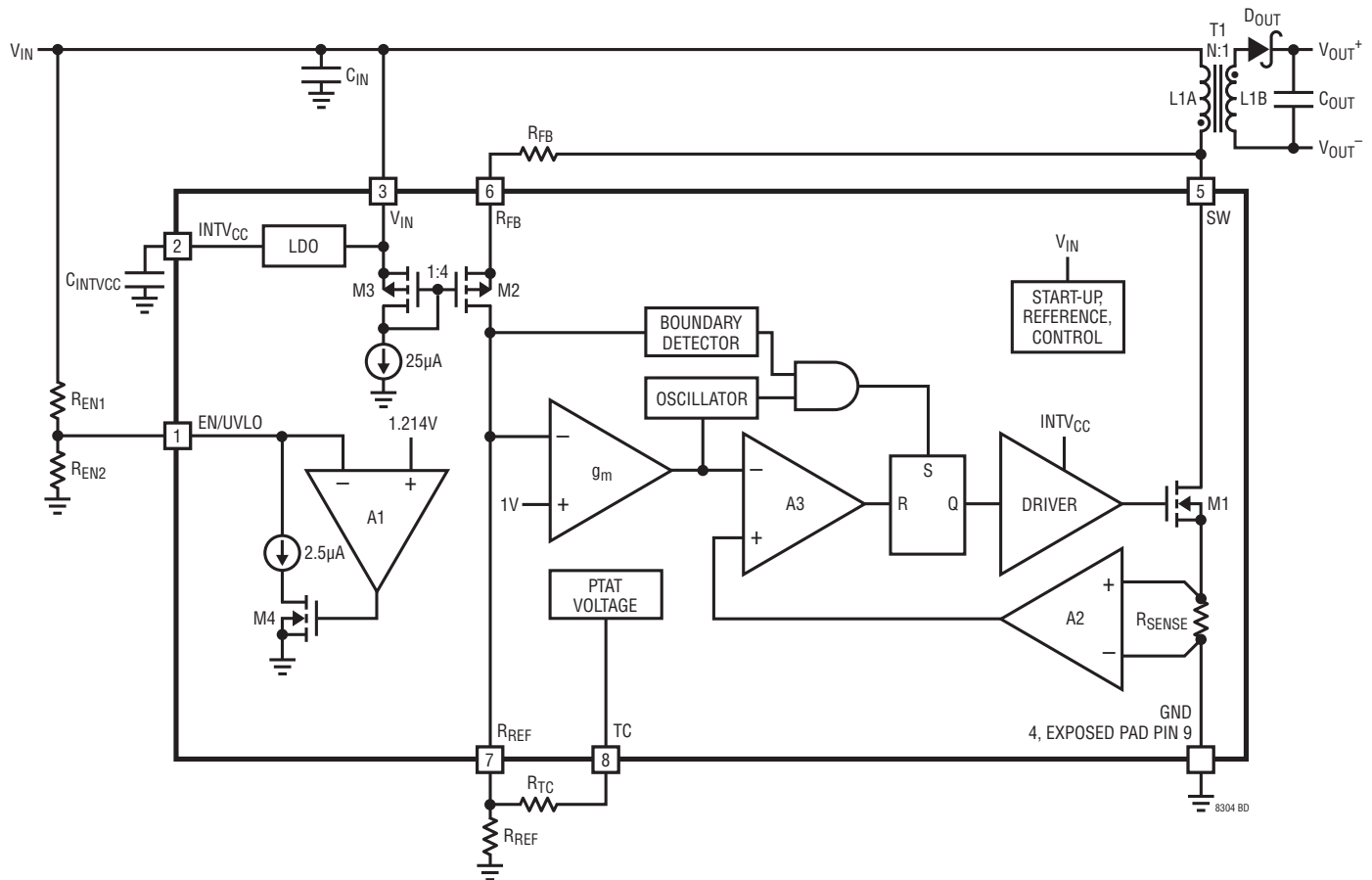

OPERATION

The LT8304 is a current mode switching regulator IC designed specially for the isolated flyback topology. The key problem in isolated topologies is how to communicate the output voltage information from the isolated secondary side of the transformer to the primary side for regulation. Historically, opto-isolators or extra transformer windings communicate this information across the isolation boundary. Opto-isolator circuits waste output power, and the extra components increase the cost and physical size of the power supply. Opto-isolators can also cause system issues due to limited dynamic response, nonlinearity, unit-to-unit variation and aging over lifetime. Circuits employing

extra transformer windings also exhibit deficiencies, as using an extra winding adds to the transformer's physical size and cost, and dynamic response is often mediocre.

The LT8304 samples the isolated output voltage through the primary-side flyback pulse waveform. In this manner, neither opto-isolator nor extra transformer winding is required for regulation. Since the LT8304 operates in either boundary conduction mode or discontinuous conduction mode, the output voltage is always sampled on the SW pin when the secondary current is zero. This method improves load regulation without the need of external load compensation components.

OPERATION

The LT8304 is a simple to use micropower isolated flyback converter housed in a thermally enhanced 8-lead SO package. The output voltage is programmed with two external resistors. An optional TC resistor provides easy output diode temperature compensation. By integrating the loop compensation and soft-start inside, the part reduces the number of external components. As shown in the Block Diagram, many of the blocks are similar to those found in traditional switching regulators including reference, regulators, oscillator, logic, current amplifier, current comparator, driver, and power switch. The novel sections include a flyback pulse sense circuit, a sample-and-hold error amplifier, and a boundary mode detector, as well as the additional logic for boundary conduction mode, discontinuous conduction mode, and low ripple Burst Mode operation.

Quasi-Resonant Boundary Mode Operation

The LT8304 features quasi-resonant boundary conduction mode operation at heavy load, where the chip turns on the primary power switch when the secondary current is zero and the SW rings to its valley. Boundary conduction mode is a variable frequency, variable peak-current switching scheme. The power switch turns on and the transformer primary current increases until an internally controlled peak current limit. After the power switch turns off, the voltage on the SW pin rises to the output voltage multiplied by the primary-to-secondary transformer turns ratio plus the input voltage. When the secondary current through the output diode falls to zero, the SW pin voltage collapses and rings around V_{IN} . A boundary mode detector senses this event and turns the power switch back on at its valley.

Boundary conduction mode returns the secondary current to zero every cycle, so parasitic resistive voltage drops do not cause load regulation errors. Boundary conduction mode also allows the use of smaller transformers compared to continuous conduction mode and does not exhibit subharmonic oscillation.

Discontinuous Conduction Mode Operation

As the load gets lighter, boundary conduction mode increases the switching frequency and decreases the switch peak current at the same ratio. Running at a higher switching frequency up to several MHz increases switching and gate charge losses. To avoid this scenario, the LT8304 has an additional internal oscillator, which clamps the maximum switching frequency to be less than 350kHz (TYP). Once the switching frequency hits the internal frequency clamp, the part starts to delay the switch turn-on and operates in discontinuous conduction mode.

Low Ripple Burst Mode Operation

Unlike traditional flyback converters, the LT8304 has to turn on and off at least for a minimum amount of time and with a minimum frequency to allow accurate sampling of the output voltage. The inherent minimum switch current limit and minimum switch-off time are necessary to guarantee the correct operation of specific applications.

As the load gets very light, the LT8304 starts to fold back the switching frequency while keeping the minimum switch current limit. So the load current is able to decrease while still allowing minimum switch-off time for the sample-and-hold error amplifier. Meanwhile, the part switches between sleep mode and active mode, thereby reducing the effective quiescent current to improve light load efficiency. In this condition, the LT8304 runs in low ripple Burst Mode operation. The typical 11kHz minimum switching frequency determines how often the output voltage is sampled and also the minimum load requirement.

High Step-Up V_{OUT} Applications

Typically, high step-up output applications have excessive primary inductor current ringing during primary switch turn-on due to the huge reflected capacitance on SW node. Such current ringing can falsely trigger LT8304 current comparator after 160ns typical blanking time and create large signal oscillation, especially at high V_{IN} and light load condition. The LT8304-1, specially optimized for high step-up output applications, is more immune to the current ringing without requiring longer blanking time. For any 1:N step-up transformer turns ratio larger than or equal to 5, the LT8304-1 is recommended.

APPLICATIONS INFORMATION

Output Voltage

The R_{FB} and R_{REF} resistors as depicted in the Block Diagram are external resistors used to program the output voltage. The LT8304 operates similar to traditional current mode switchers, except in the use of a unique flyback pulse sense circuit and a sample-and-hold error amplifier, which sample and therefore regulate the isolated output voltage from the flyback pulse.

Operation is as follows: when the power switch M1 turns off, the SW pin voltage rises above the V_{IN} supply. The amplitude of the flyback pulse, i.e., the difference between the SW pin voltage and V_{IN} supply, is given as:

$$V_{FLBK} = (V_{OUT} + V_F + I_{SEC} \cdot ESR) \cdot N_{PS}$$

V_F = Output diode forward voltage

I_{SEC} = Transformer secondary current

ESR = Total impedance of secondary circuit

N_{PS} = Transformer effective primary-to-secondary turns ratio

The flyback voltage is then converted to a current, I_{RFB} , by the R_{FB} resistor and the flyback pulse sense circuit (M2 and M3). This current, I_{RFB} , also flows through the R_{REF} resistor to generate a ground-referred voltage. The resulting voltage feeds to the inverting input of the sample-and-hold error amplifier. Since the sample-and-hold error amplifier samples the voltage when the secondary current is zero, the $(I_{SEC} \cdot ESR)$ term in the V_{FLBK} equation can be assumed to be zero.

The internal reference voltage, V_{REF} , 1.00V, feeds to the noninverting input of the sample-and-hold error amplifier. The relatively high gain in the overall loop causes the voltage at the R_{REF} pin to be nearly equal to the internal reference voltage V_{REF} . The resulting relationship between V_{FLBK} and V_{REF} can be expressed as:

$$\left(\frac{V_{FLBK}}{R_{FB}} \right) \cdot R_{REF} = V_{REF} \text{ or}$$

$$V_{FLBK} = V_{REF} \cdot \left(\frac{R_{FB}}{R_{REF}} \right)$$

V_{REF} = Internal reference voltage 1.00V

Combination with the previous V_{FLBK} equation yields an equation for V_{OUT} , in terms of the R_{FB} and R_{REF} resistors, transformer turns ratio, and diode forward voltage:

$$V_{OUT} = V_{REF} \cdot \left(\frac{R_{FB}}{R_{REF}} \right) \cdot \left(\frac{1}{N_{PS}} \right) - V_F$$

Output Temperature Compensation

The first term in the V_{OUT} equation does not have temperature dependence, but the output diode forward voltage, V_F , has a significant negative temperature coefficient ($-1\text{mV}/^\circ\text{C}$ to $-2\text{mV}/^\circ\text{C}$). Such a negative temperature coefficient produces approximately 200mV to 300mV voltage variation on the output voltage across temperature.

For higher voltage outputs, such as 12V and 24V, the output diode temperature coefficient has a negligible effect on the output voltage regulation. For lower voltage outputs, such as 3.3V and 5V, however, the output diode temperature coefficient does count for an extra 2% to 5% output voltage regulation.

The LT8304 junction temperature usually tracks the output diode junction temperature to the first order. To compensate the negative temperature coefficient of the output diode, a resistor, R_{TC} , connected between the TC and R_{REF} pins generates a proportional-to-absolute-temperature (PTAT) current. The PTAT current is zero at 25°C , flows into the R_{REF} pin at hot temperature, and flows out of the R_{REF} pin at cold temperature. With the R_{TC} resistor in place, the output voltage equation is revised as follows:

$$V_{OUT} = V_{REF} \cdot \left(\frac{R_{FB}}{R_{REF}} \right) \cdot \left(\frac{1}{N_{PS}} \right) - V_F(TO) - (\delta V_{TC} / \delta T) \cdot (T - TO) \cdot \left(\frac{R_{FB}}{R_{TC}} \right) \cdot \left(\frac{1}{N_{PS}} \right) - (\delta V_F / \delta T) \cdot (T - TO)$$

TO = Room temperature 25°C

$(\delta V_F / \delta T)$ = Output diode forward voltage temperature coefficient

$(\delta V_{TC} / \delta T) = 3.35\text{mV}/^\circ\text{C}$

APPLICATIONS INFORMATION

To cancel the output diode temperature coefficient, the following two equations should be satisfied:

$$V_{OUT} = V_{REF} \cdot \left(\frac{R_{FB}}{R_{REF}} \right) \cdot \left(\frac{1}{N_{PS}} \right) - V_F(TO)$$

$$(\delta V_{TC}/\delta T) \cdot \left(\frac{R_{FB}}{R_{TC}} \right) \cdot \left(\frac{1}{N_{PS}} \right) = -(\delta V_F/\delta T)$$

Selecting Actual R_{REF} , R_{FB} , R_{TC} Resistor Values

The LT8304 uses a unique sampling scheme to regulate the isolated output voltage. Due to the sampling nature, the scheme contains repeatable delays and error sources, which will affect the output voltage and force a re-evaluation of the R_{FB} and R_{TC} resistor values. Therefore, a simple 2-step sequential process is recommended for selecting resistor values.

Rearrangement of the expression for V_{OUT} in the previous sections yields the starting value for R_{FB} :

$$R_{FB} = \frac{R_{REF} \cdot N_{PS} \cdot (V_{OUT} + V_F(TO))}{V_{REF}}$$

V_{OUT} = Output voltage

$V_F(TO)$ = Output diode forward voltage at 25°C = ~0.3V

N_{PS} = Transformer effective primary-to-secondary turns ratio

The equation shows that the R_{FB} resistor value is independent of the R_{TC} resistor value. Any R_{TC} resistor connected between the TC and R_{REF} pins has no effect on the output voltage setting at 25°C because the TC pin voltage is equal to the R_{REF} regulation voltage at 25°C.

The R_{REF} resistor value should be approximately 10k because the LT8304 is trimmed and specified using this value. If the R_{REF} resistor value varies considerably from 10k, additional errors will result. However, a variation in R_{REF} up to 10% is acceptable. This yields a bit of freedom in selecting standard 1% resistor values to yield nominal R_{FB}/R_{REF} ratios.

First, build and power up the application with the starting R_{REF} , R_{FB} values (no R_{TC} resistor yet) and other components connected, and measure the regulated output voltage, $V_{OUT(MEAS)}$. The new R_{FB} value can be adjusted to:

$$R_{FB(NEW)} = \frac{V_{OUT}}{V_{OUT(MEAS)}} \cdot R_{FB}$$

Second, with a new R_{FB} resistor value selected, the output diode temperature coefficient in the application can be tested to determine the R_{TC} value. Still without the R_{TC} resistor, the V_{OUT} should be measured over temperature at a desired target output load. It is very important for this evaluation that uniform temperature be applied to both the output diode and the LT8304. If freeze spray or a heat gun is used, there can be a significant mismatch in temperature between the two devices that causes significant error. Attempting to extrapolate the data from a diode data sheet is another option if there is no method to apply uniform heating or cooling such as an oven. With at least two data points spreading across the operating temperature range, the output diode temperature coefficient can be determined by:

$$-(\delta V_F/\delta T) = \frac{V_{OUT}(T1) - V_{OUT}(T2)}{T1 - T2}$$

Using the measured output diode temperature coefficient, an exact R_{TC} value can be selected with the following equation:

$$R_{TC} = \frac{(\delta V_{TC}/\delta T)}{-(\delta V_F/\delta T)} \cdot \left(\frac{R_{FB}}{N_{PS}} \right)$$

Once the R_{REF} , R_{FB} , and R_{TC} values are selected, the regulation accuracy from board to board for a given application will be very consistent, typically under $\pm 5\%$ when including device variation of all the components in the system (assuming resistor tolerances and transformer windings matching within $\pm 1\%$). However, if the transformer or the output diode is changed, or the layout is dramatically altered, there may be some change in V_{OUT} .

APPLICATIONS INFORMATION

Output Power

A flyback converter has a complicated relationship between the input and output currents compared to a buck or a boost converter. A boost converter has a relatively constant maximum input current regardless of input voltage and a buck converter has a relatively constant maximum output current regardless of input voltage. This is due to the continuous non-switching behavior of the two currents. A flyback converter has both discontinuous input and output currents which make it similar to a nonisolated buck-boost converter. The duty cycle will affect the input and output currents, making it hard to predict output power. In addition, the winding ratio can be changed to multiply the output current at the expense of a higher switch voltage.

The graphs in Figures 1 to 4 show the typical maximum output power possible for the output voltages 3.3V, 5V,

12V, and 24V. The maximum output power curve is the calculated output power if the switch voltage is 110V during the switch-off time. 40V of margin is left for leakage inductance voltage spike. To achieve this power level at a given input, a winding ratio value must be calculated to stress the switch to 110V, resulting in some odd ratio values. The curves below the maximum output power curve are examples of common winding ratio values and the amount of output power at given input voltages.

One design example would be a 5V output converter with a minimum input voltage of 36V and a maximum input voltage of 75V. A six-to-one winding ratio fits this design example perfectly and outputs equal to 19.0W at 75V but lowers to 14.4W at 36V.

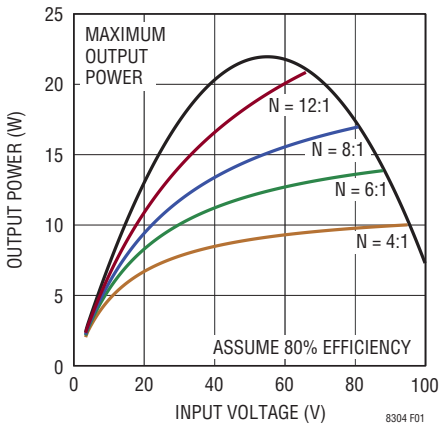

Figure 1. Output Power for 3.3V Output

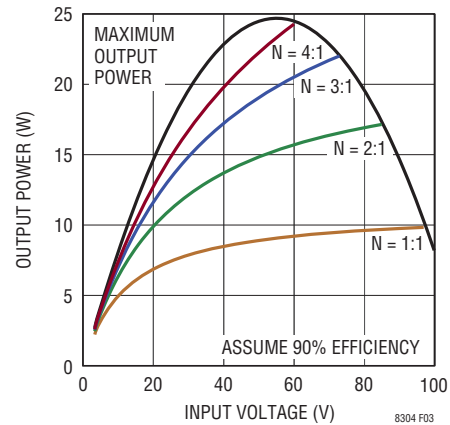

Figure 3. Output Power for 12V Output

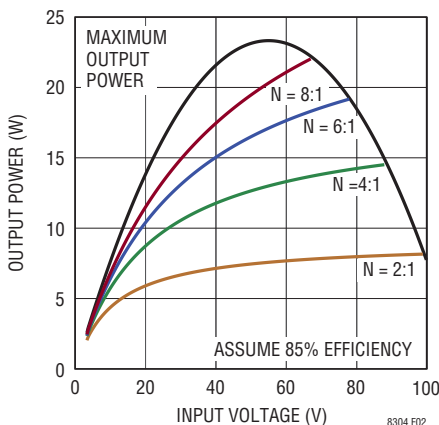

Figure 2. Output Power for 5V Output

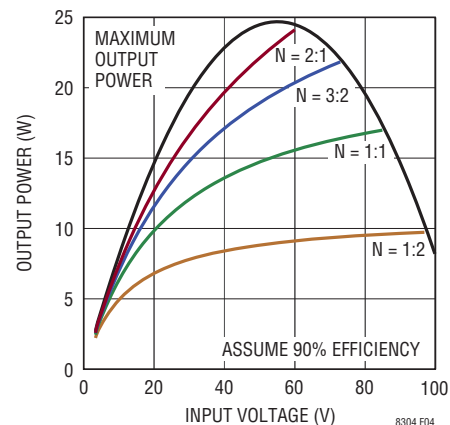

Figure 4. Output Power for 24V Output

8304fa

APPLICATIONS INFORMATION

The equations below calculate output power:

$$P_{OUT} = \eta \cdot V_{IN} \cdot D \cdot I_{SW(MAX)} \cdot 0.5$$

η = Efficiency = ~85%

$$D = \text{Duty Cycle} = \frac{(V_{OUT} + V_F) \cdot N_{PS}}{(V_{OUT} + V_F) \cdot N_{PS} + V_{IN}}$$

$I_{SW(MAX)}$ = Maximum switch current limit = 2A (MIN)

Primary Inductance Requirement

The LT8304 obtains output voltage information from the reflected output voltage on the SW pin. The conduction of secondary current reflects the output voltage on the primary SW pin. The sample-and-hold error amplifier needs a minimum 350ns to settle and sample the reflected output voltage. In order to ensure proper sampling, the secondary winding needs to conduct current for a minimum of 350ns. The following equation gives the minimum value for primary-side magnetizing inductance:

$$L_{PRI} \geq \frac{t_{OFF(MIN)} \cdot N_{PS} \cdot (V_{OUT} + V_F)}{I_{SW(MIN)}}$$

$t_{OFF(MIN)}$ = Minimum switch-off time = 350ns (TYP)

$I_{SW(MIN)}$ = Minimum switch current limit = 0.48A (TYP)

In addition to the primary inductance requirement for the minimum switch-off time, the LT8304 has minimum switch-on time that prevents the chip from turning on

the power switch shorter than approximately 160ns. This minimum switch-on time is mainly for leading-edge blanking the initial switch turn-on current spike. If the inductor current exceeds the desired current limit during that time, oscillation may occur at the output as the current control loop will lose its ability to regulate. Therefore, the following equation relating to maximum input voltage must also be followed in selecting primary-side magnetizing inductance:

$$L_{PRI} \geq \frac{t_{ON(MIN)} \cdot V_{IN(MAX)}}{I_{SW(MIN)}}$$

$t_{ON(MIN)}$ = Minimum switch-on time = 160ns (TYP)

In general, choose a transformer with its primary magnetizing inductance about 40% to 60% larger than the minimum values calculated above. A transformer with much larger inductance will have a bigger physical size and may cause instability at light load.

Selecting a Transformer

Transformer specification and design is perhaps the most critical part of successfully applying the LT8304. In addition to the usual list of guidelines dealing with high frequency isolated power supply transformer design, the following information should be carefully considered.

Linear Technology has worked with several leading magnetic component manufacturers to produce pre-designed flyback transformers for use with the LT8304. Table 1 shows the details of these transformers.

Table 1. Pre-designed Transformers – Typical Specifications

TRANSFORMER PART NUMBER	DIMENSION (W x L x H) (mm)	L _{PRI} (μH) TYP	L _{LKG} (μH) TYP (MAX)	N _p :N _s	VENDOR	TARGET APPLICATION		
						V _{IN} (V)	V _{OUT} (V)	I _{OUT} (A)
750315125	17.75 x 13.46 x 12.70	40	1 (2)	6:1	Würth Elektronik	36 – 75	5	3
750315126	17.75 x 13.46 x 12.70	40	0.5 (1)	2:1	Würth Elektronik	36 – 75	12	1.2
750315835	17.75 x 13.46 x 12.70	40	1 (2)	8:1	Würth Elektronik	36 – 75	3.3	4.2
750315836	17.75 x 13.46 x 12.70	40	0.45 (0.9)	1:1	Würth Elektronik	36 – 75	24	0.6
750315837	17.75 x 13.46 x 12.70	40	0.5 (1)	1:2	Würth Elektronik	36 – 75	48	0.3
750315839	17.75 x 13.46 x 12.71	40	0.25 (0.5)	1:10	Würth Elektronik	4 – 36	200	0.012
13324-T083	18.0 x 13.5 x 12.5	40	(2)	8:1	Sumida	36 – 75	3.3	4.2
13324-T084	18.0 x 13.5 x 12.5	40	(1.2)	1:1	Sumida	36 – 75	24	0.6
13324-T085	18.0 x 13.5 x 12.5	40	(1.2)	1:2	Sumida	36 – 75	48	0.3
13324-T086	18.0 x 13.5 x 12.6	40	(1.2)	1:5	Sumida	4 – 36	200	0.012
13324-T087	18.0 x 13.5 x 12.5	40	(1.2)	1:10	Sumida	4 – 18	400	0.006

8304fa

APPLICATIONS INFORMATION

Turns Ratio

Note that when choosing an R_{FB}/R_{REF} resistor ratio to set output voltage, the user has relative freedom in selecting a transformer turns ratio to suit a given application. In contrast, the use of simple ratios of small integers, e.g., 3:1, 2:1, 1:1, etc., provides more freedom in settling total turns and mutual inductance.

Typically, choose the transformer turns ratio to maximize available output power. For low output voltages (3.3V or 5V), a N:1 turns ratio can be used with multiple primary windings relative to the secondary to maximize the transformer's current gain (and output power). However, remember that the SW pin sees a voltage that is equal to the maximum input supply voltage plus the output voltage multiplied by the turns ratio. In addition, leakage inductance will cause a voltage spike ($V_{LEAKAGE}$) on top of this reflected voltage. This total quantity needs to remain below the 150V absolute maximum rating of the SW pin to prevent breakdown of the internal power switch. Together these conditions place an upper limit on the turns ratio, N_{PS} , for a given application. Choose a turns ratio low enough to ensure

$$N_{PS} < \frac{150V - V_{IN(MAX)} - V_{LEAKAGE}}{V_{OUT} + V_F}$$

For larger N:1 step-down turns ratio, choose a transformer with a larger physical size to deliver additional current. In addition, choose a large enough inductance value to ensure that the switch-off time is long enough to accurately sample the output voltage. Always choose the LT8304 for N:1 step-down transformer turns ratio.

For lower output power levels or higher output voltage, choose a 1:1 or 1:N step-up transformer for the absolute smallest transformer size. A 1:N step-up transformer will minimize the magnetizing inductance and size, but will also limit the available output power. A higher 1:N step-up turns ratio makes it possible to have very high output voltages without exceeding the breakdown voltage of the internal power switch. For any 1:N step-up transformer turns ratio larger than or equal to 5, the LT8304-1 is recommended.

The turns ratio is an important element in the isolated feedback scheme, and directly affects the output voltage accuracy. Make sure the transformer manufacturer specifies turns ratio accuracy within $\pm 1\%$.

Saturation Current

The current in the transformer windings should not exceed its rated saturation current. Energy injected once the core is saturated will not be transferred to the secondary and will instead be dissipated in the core. When designing custom transformers to be used with the LT8304, the saturation current should always be specified by the transformer manufacturers.

Winding Resistance

Resistance in either the primary or secondary windings will reduce overall power efficiency. Good output voltage regulation will be maintained independent of winding resistance due to the boundary/discontinuous conduction mode operation of the LT8304.

Leakage Inductance and Snubbers

Transformer leakage inductance on either the primary or secondary causes a voltage spike to appear on the primary after the power switch turns off. This spike is increasingly prominent at higher load currents where more stored energy must be dissipated. It is very important to minimize transformer leakage inductance.

When designing an application, adequate margin should be kept for the worst-case leakage voltage spikes even under overload conditions. In most cases shown in Figure 5, the reflected output voltage on the primary plus V_{IN} should be kept below 110V. This leaves at least 40V margin for the leakage spike across line and load conditions. A larger voltage margin will be required for poorly wound transformers or for excessive leakage inductance.

APPLICATIONS INFORMATION

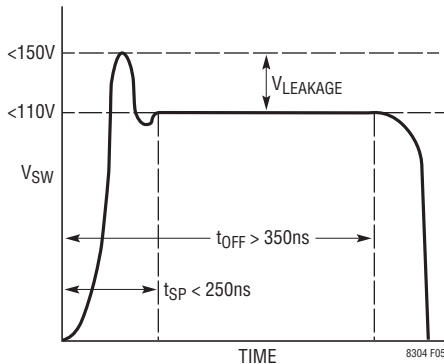

Figure 5. Maximum Voltages for SW Pin Flyback Waveform

In addition to the voltage spikes, the leakage inductance also causes the SW pin ringing for a while after the power switch turns off. To prevent the voltage ringing falsely trigger boundary mode detector, the LT8304 internally blanks the boundary mode detector for approximately 250ns. Any remaining voltage ringing after 250ns may turn the power switch back on again before the secondary current falls to zero. In this case, the LT8304 enters continuous conduction mode. So the leakage inductance spike ringing should be limited to less than 250ns.

To clamp and damp the leakage voltage spikes, a (RC + DZ) snubber circuit in Figure 6 is recommended. The RC (resistor-capacitor) snubber quickly damps the voltage spike ringing and provides great load regulation and EMI performance. And the DZ (diode-Zener) ensures well defined and consistent clamping voltage to protect SW pin from exceeding its 150V absolute maximum rating.

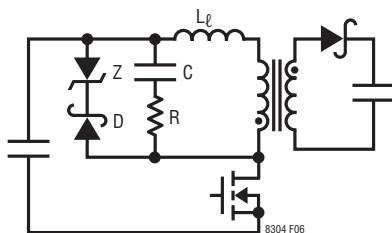

Figure 6. (RC + DZ) Snubber Circuit

The recommended approach for designing an RC snubber is to measure the period of the ringing on the SW pin when the power switch turns off without the snubber and

then add capacitance until the period of the ringing is 1.5 to 2 times longer. The change in period determines the value of the parasitic capacitance, from which the parasitic inductance can be also determined from the initial period. Once the value of the SW node capacitance and inductance is known, a series resistor can be added to the snubber capacitance to dissipate power and critically damp the ringing. The equation for deriving the optimal series resistance using the observed periods (t_{PERIOD} and $t_{PERIOD(SNUBBED)}$) and snubber capacitance ($C_{SNUBBER}$) is:

$$C_{PAR} = \frac{C_{SNUBBER}}{\left(\frac{t_{PERIOD(SNUBBED)}}{t_{PERIOD}}\right)^2 - 1}$$

$$L_{PAR} = \frac{t_{PERIOD}^2}{C_{PAR} \cdot 4\pi^2}$$

$$R_{SNUBBER} = \sqrt{\frac{L_{PAR}}{C_{PAR}}}$$

Note that energy absorbed by the RC snubber will be converted to heat and will not be delivered to the load. In high voltage or high current applications, the snubber needs to be sized for thermal dissipation. A 220pF capacitor in series with a 100 Ω resistor is a good starting point.

For the DZ snubber, proper care should be taken when choosing both the diode and the Zener diode. Schottky diodes are typically the best choice, but some PN diodes can be used if they turn on fast enough to limit the leakage inductance spike. Choose a diode that has a reverse-voltage rating higher than the maximum SW pin voltage. The Zener diode breakdown voltage should be chosen to balance power loss and switch voltage protection. The best compromise is to choose the largest voltage breakdown with 5V margin. Use the following equation to make the proper choice:

$$V_{ZENER(MAX)} \leq 145\text{V} - V_{IN(MAX)}$$

For an application with a maximum input voltage of 80V, choose a 62V Zener diode, the $V_{ZENER(MAX)}$ of which is around 65V. The power loss in the DZ snubber determines the power rating of the Zener diode. A 1.5W Zener diode is typically recommended.

APPLICATIONS INFORMATION

Undervoltage Lockout (UVLO)

A resistive divider from V_{IN} to the EN/UVLO pin implements undervoltage lockout (UVLO). The EN/UVLO enable falling threshold is set at 1.214V with 14mV hysteresis. In addition, the EN/UVLO pin sinks 2.5 μ A when the voltage on the pin is below 1.214V. This current provides user programmable hysteresis based on the value of R1. The programmable UVLO thresholds are:

$$V_{IN(UVLO^+)} = \frac{1.228V \cdot (R1+R2)}{R2} + 2.5\mu A \cdot R1$$

$$V_{IN(UVLO^-)} = \frac{1.214V \cdot (R1+R2)}{R2}$$

Figure 7 shows the implementation of external shutdown control while still using the UVLO function. The NMOS grounds the EN/UVLO pin when turned on, and puts the LT8304 in shutdown with quiescent current less than 3 μ A.

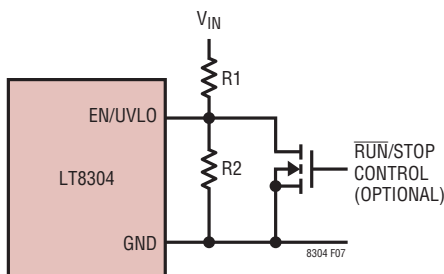

Figure 7. Undervoltage Lockout (UVLO)

Minimum Load Requirement

The LT8304 samples the isolated output voltage from the primary-side flyback pulse waveform. The flyback pulse occurs once the primary switch turns off and the secondary winding conducts current. In order to sample the output voltage, the LT8304 has to turn on and off for a minimum amount of time and with a minimum frequency. The LT8304 delivers a minimum amount of energy even

during light load conditions to ensure accurate output voltage information. The minimum energy delivery creates a minimum load requirement, which can be approximately estimated as:

$$I_{LOAD(MIN)} = \frac{L_{PRI} \cdot I_{SW(MIN)}^2 \cdot f_{MIN}}{2 \cdot V_{OUT}}$$

L_{PRI} = Transformer primary inductance

$I_{SW(MIN)}$ = Minimum switch current limit = 0.53A (MAX)

f_{MIN} = Minimum switching frequency = 14kHz (MAX)

The LT8304 typically needs less than 0.5% of its full output power as minimum load. Alternatively, a Zener diode with its breakdown of 10% higher than the output voltage can serve as a minimum load if pre-loading is not acceptable. For a 5V output, use a 5.6V Zener with cathode connected to the output. The LT8304-1 requires slightly higher minimum load, typically 2% of full load.

Output Short Protection

When the output is heavily overloaded or shorted to ground, the reflected SW pin waveform rings longer than the internal blanking time. After the 350ns minimum switch-off time, the excessive ringing falsely triggers the boundary mode detector and turns the power switch back on again before the secondary current falls to zero. Under this condition, the LT8304 runs into continuous conduction mode at 350kHz (TYP) maximum switching frequency. If the sampled R_{REF} voltage is still less than 0.6V after 11ms (typ) soft-start timer, the LT8304 initiates a new soft-start cycle. If the sampled R_{REF} voltage is larger than 0.6V after 11ms, the switch current may run away and exceed the 2.4A maximum current limit. Once the switch current hits 3.6A over current limit, the LT8304 also initiates a new soft-start cycle. Under either condition, the new soft-start cycle throttles back both the switch current limit and switch frequency. The output short-circuit protection prevents the switch current from running away and limits the average output diode current.

APPLICATIONS INFORMATION

Design Example

Use the following design example as a guide to designing applications for the LT8304. The design example involves designing a 5V output with a 2.8A load current and an input range from 36V to 75V.

$$V_{IN(MIN)} = 36V, V_{IN(NOM)} = 48V, V_{IN(MAX)} = 75V, \\ V_{OUT} = 5V, I_{OUT} = 2.8A$$

Step 1: Select the transformer turns ratio.

$$N_{PS} < \frac{150V - V_{IN(MAX)} - V_{LEAKAGE}}{V_{OUT} + V_F}$$

$V_{LEAKAGE}$ = Margin for transformer leakage spike = 40V

V_F = Output diode forward voltage = ~0.3V

Example:

$$N_{PS} < \frac{150V - 75V - 40V}{5V + 0.3V} = 6.6$$

The choice of transformer turns ratio is critical in determining output current capability of the converter. Table 2 shows the switch voltage stress and output current capability at different transformer turns ratio.

Table 2. Switch Voltage Stress and Output Current Capability vs Turns Ratio

NPS	$V_{SW(MAX)}$ at $V_{IN(MAX)}$ (V)	$I_{OUT(MAX)}$ at $V_{IN(MIN)}$ (A)	DUTY CYCLE (%)
4:1	96.2	2.27	22 to 37
5:1	101.5	2.59	26 to 42
6:1	106.8	2.87	30 to 47

Clearly, only $N_{PS} = 6$ can meet the 2.8A output current requirement, so $N_{PS} = 6$ is chosen as the turns ratio in this example.

Step 2: Determine the primary inductance.

Primary inductance for the transformer must be set above a minimum value to satisfy the minimum switch-off and switch-on time requirements:

$$L_{PRI} \geq \frac{t_{OFF(MIN)} \cdot N_{PS} \cdot (V_{OUT} + V_F)}{I_{SW(MIN)}}$$

$$L_{PRI} \geq \frac{t_{ON(MIN)} \cdot V_{IN(MAX)}}{I_{SW(MIN)}}$$

$$t_{OFF(MIN)} = 350ns$$

$$t_{ON(MIN)} = 160ns$$

$$I_{SW(MIN)} = 0.48A$$

Example:

$$L_{PRI} \geq \frac{350ns \cdot 6 \cdot (5V + 0.3V)}{0.48A} = 23\mu H$$

$$L_{PRI} \geq \frac{160ns \cdot 75V}{0.48A} = 25\mu H$$

Most transformers specify primary inductance with a tolerance of $\pm 20\%$. With other component tolerance considered, choose a transformer with its primary inductance 40% to 60% larger than the minimum values calculated above. $L_{PRI} = 40\mu H$ is then chosen in this example.

The transformer also needs to be rated for the correct saturation current level across line and load conditions. A saturation current rating larger than 2.8A is necessary to work with the LT8304. The 750315125 from Würth is chosen as the flyback transformer.

APPLICATIONS INFORMATION

Step 3: Choose the output diode.

Two main criteria for choosing the output diode include forward current rating and reverse-voltage rating. The maximum load requirement is a good first-order guess at the average current requirement for the output diode. Under output short-circuit condition, the output diode needs to conduct much higher current. Therefore, a conservative metric is 60% of the maximum switch current limit multiplied by the turns ratio:

$$I_{\text{DIODE(MAX)}} = 0.6 \cdot I_{\text{SW(MAX)}} \cdot N_{\text{PS}}$$

Example:

$$I_{\text{DIODE(MAX)}} = 8.6\text{A}$$

Next calculate reverse voltage requirement using maximum V_{IN} :

$$V_{\text{REVERSE}} = V_{\text{OUT}} + \frac{V_{\text{IN(MAX)}}}{N_{\text{PS}}}$$

Example:

$$V_{\text{REVERSE}} = 5\text{V} + \frac{75\text{V}}{6} = 17.5\text{V}$$

The PDS835L (8A, 35V diode) from Diodes Inc. is chosen.

Step 4: Choose the output capacitor.

The output capacitor should be chosen to minimize the output voltage ripple while considering the increase in size and cost of a larger capacitor. Use the following equation to calculate the output capacitance:

$$C_{\text{OUT}} = \frac{L_{\text{PRI}} \cdot I_{\text{SW}}^2}{2 \cdot V_{\text{OUT}} \cdot \Delta V_{\text{OUT}}}$$

Example:

Design for output voltage ripple less than $\pm 1\%$ of V_{OUT} , i.e., 100mV.

$$C_{\text{OUT}} = \frac{40\mu\text{H} \cdot (2.4\text{A})^2}{2 \cdot 5\text{V} \cdot 0.1\text{V}} = 230\mu\text{F}$$

Remember ceramic capacitors lose capacitance with applied voltage. The capacitance can drop up to 40% of quoted capacitance at the maximum voltage rating. So three 100 μF , 10V rating ceramic capacitors are chosen.

Step 5: Design snubber circuit.

The snubber circuit protects the power switch from leakage inductance voltage spike. A (RC + DZ) snubber is recommended for this application. A 220pF capacitor in series with a 100 Ω resistor is chosen as the RC snubber.

The maximum Zener breakdown voltage is set according to the maximum V_{IN} :

$$V_{\text{ZENNER(MAX)}} \leq 145\text{V} - V_{\text{IN(MAX)}}$$

Example:

$$V_{\text{ZENNER(MAX)}} \leq 145\text{V} - 75\text{V} = 70\text{V}$$

A 62V Zener with a maximum of 65V will provide optimal protection and minimize power loss. So a 62V, 1.5W Zener from Central Semiconductor (CMZ5944B) is chosen.

Choose a diode that is fast and has sufficient reverse voltage breakdown:

$$V_{\text{REVERSE}} > V_{\text{SW(MAX)}}$$

$$V_{\text{SW(MAX)}} = V_{\text{IN(MAX)}} + V_{\text{ZENNER(MAX)}}$$

Example:

$$V_{\text{REVERSE}} > 150\text{V}$$

A 150V, 1A diode from Diodes Inc. (DFLS1150) is chosen.

Step 6: Select the R_{REF} and R_{FB} resistors.

Use the following equation to calculate the starting values for R_{REF} and R_{FB} :

$$R_{\text{FB}} = \frac{R_{\text{REF}} \cdot N_{\text{PS}} \cdot (V_{\text{OUT}} + V_{\text{F}}(\text{TO}))}{V_{\text{REF}}}$$

$$R_{\text{REF}} = 10\text{k}$$

Example:

$$R_{\text{FB}} = \frac{10\text{k} \cdot 6 \cdot (5\text{V} + 0.3\text{V})}{1.00\text{V}} = 318\text{k}$$

For 1% standard values, a 316k resistor is chosen.

APPLICATIONS INFORMATION

Step 7: Adjust R_{FB} resistor based on output voltage.

Build and power up the application with application components and measure the regulated output voltage. Adjust R_{FB} resistor based on the measured output voltage:

$$R_{FB(NEW)} = \frac{V_{OUT}}{V_{OUT(MEASURED)}} \cdot R_{FB}$$

Example:

$$R_{FB} = \frac{5V}{5.11V} \cdot 316k = 309k$$

Step 8: Select R_{TC} resistor based on output voltage temperature variation.

Measure output voltage in a controlled temperature environment like an oven to determine the output temperature coefficient. Measure output voltage at a consistent load current and input voltage, across the operating temperature range.

Calculate the temperature coefficient of V_F :

$$-(\delta V_F / \delta T) = \frac{V_{OUT}(T1) - V_{OUT}(T2)}{T1 - T2}$$

$$R_{TC} = \frac{3.35mV/^\circ C}{-(\delta V_F / \delta T)} \cdot \left(\frac{R_{FB}}{N_{PS}} \right)$$

Example:

$$-(\delta V_F / \delta T) = \frac{5.149V - 4.977V}{100^\circ C - (0^\circ C)} = 1.72mV/^\circ C$$

$$R_{TC} = \frac{3.35mV/^\circ C}{1.72mV/^\circ C} \cdot \left(\frac{309}{6} \right) = 100k$$

Step 9: Select the EN/UVLO resistors.

Determine the amount of hysteresis required and calculate $R1$ resistor value:

$$V_{IN(HYS)} = 2.5\mu A \cdot R1$$

Example:

Choose 2.5V of hysteresis, $R1 = 1M$

Determine the UVLO thresholds and calculate $R2$ resistor value:

$$V_{IN(UVLO+)} = \frac{1.228V \cdot (R1 + R2)}{R2} + 2.5\mu A \cdot R1$$

Example:

Set V_{IN} UVLO rising threshold to 34.5V:

$$R2 = 40.2k$$

$$V_{IN(UVLO+)} = 34.3V$$

$$V_{IN(UVLO-)} = 31.4V$$

Step 10: Ensure minimum load.

The theoretical minimum load can be approximately estimated as:

$$I_{LOAD(MIN)} = \frac{40\mu H \cdot (0.53A)^2 \cdot 14kHz}{2 \cdot 5V} = 15.7mA$$

Remember to check the minimum load requirement in real application. The minimum load occurs at the point where the output voltage begins to climb up as the converter delivers more energy than what is consumed at the output. The real minimum load for this application is about 20mA. In this example, a 249 Ω resistor is selected as the minimum load.

TYPICAL APPLICATIONS

18V to 80V_{IN}/3.3V_{OUT} Isolated Flyback Converter

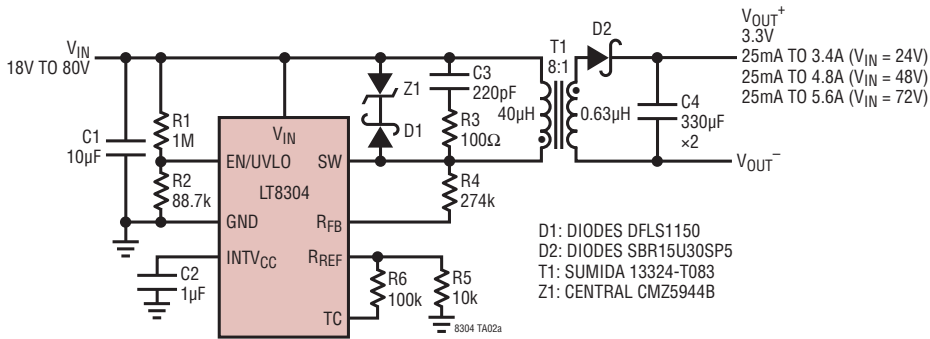

Efficiency vs Load Current

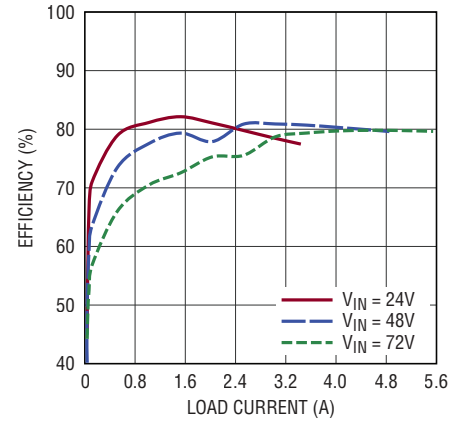

18V to 80V_{IN}/5V_{OUT} Isolated Flyback Converter

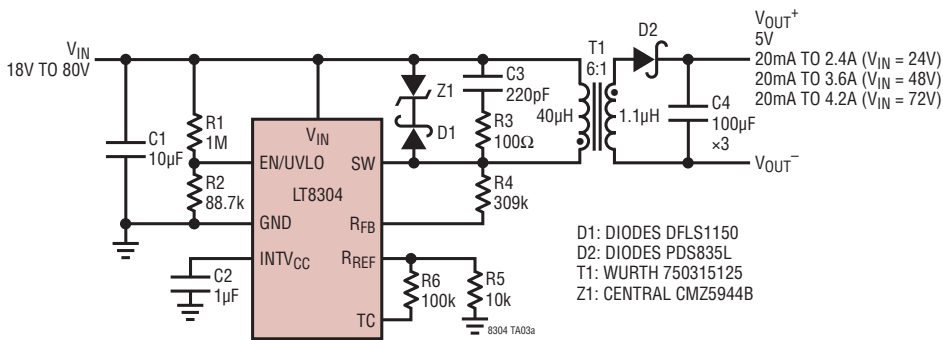

Efficiency vs Load Current

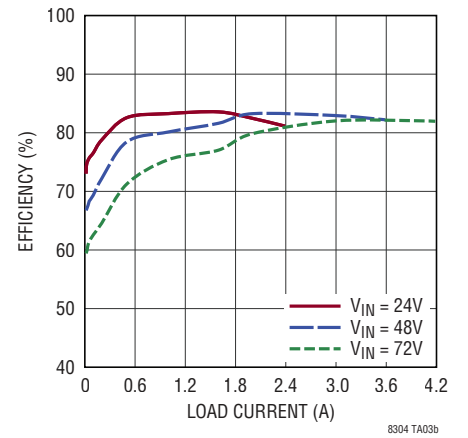

TYPICAL APPLICATIONS

18V to 80V_{IN}/12V_{OUT} Isolated Flyback Converter

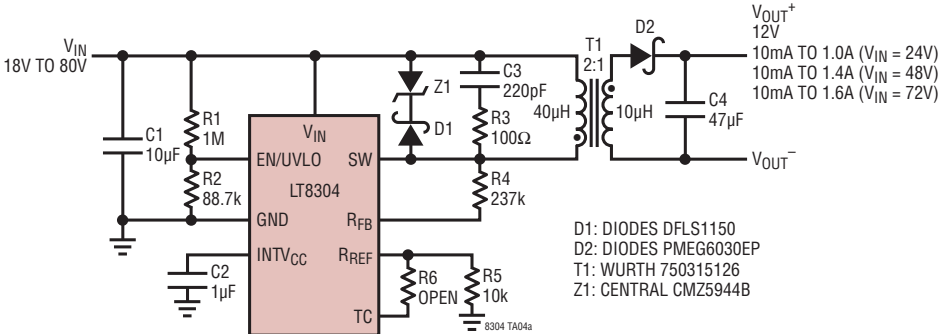

Efficiency vs Load Current

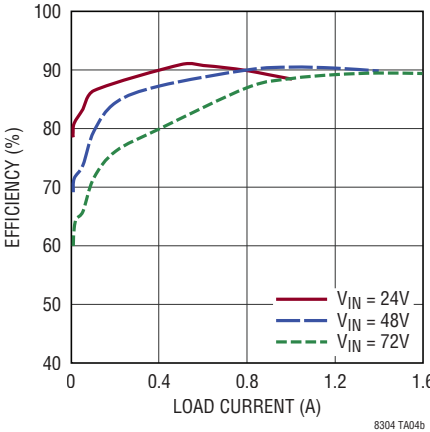

18V to 80V_{IN}/24V_{OUT} Isolated Flyback Converter

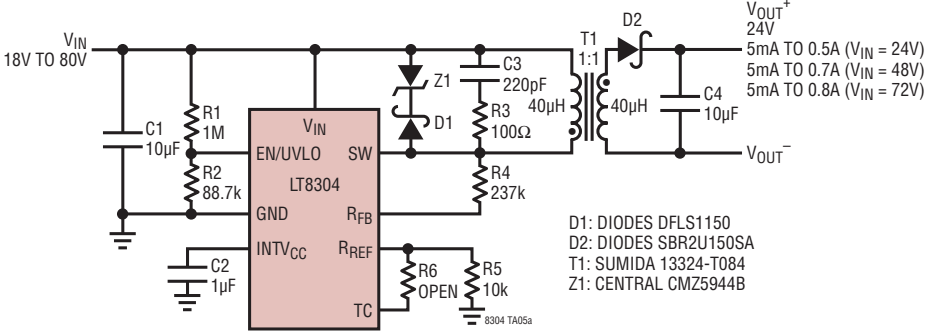

Efficiency vs Load Current

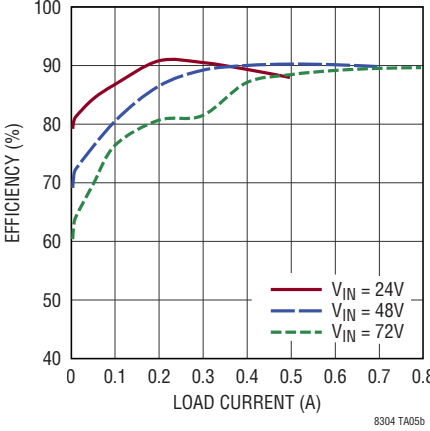

TYPICAL APPLICATIONS

18V to 80V_{IN}/48V_{OUT} Isolated Flyback Converter

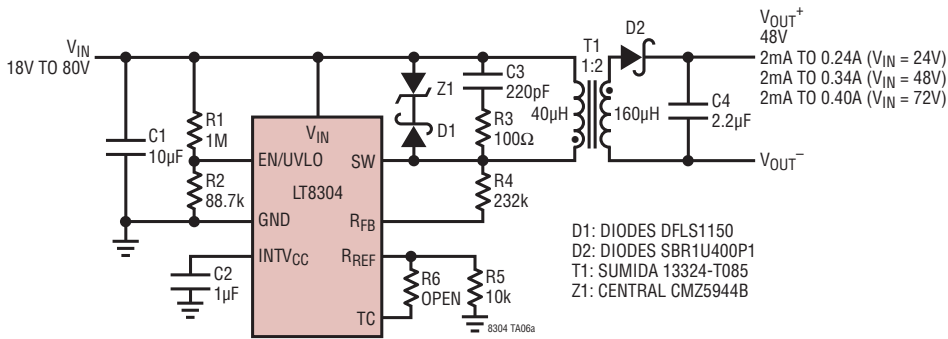

Efficiency vs Load Current

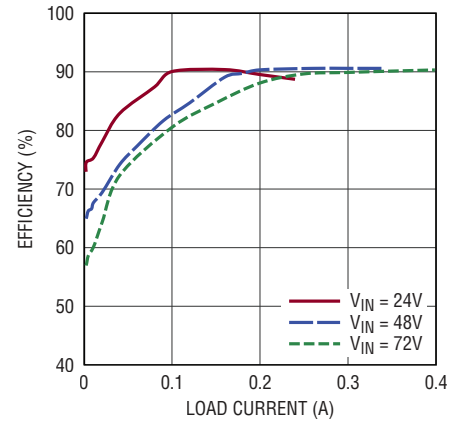

TYPICAL APPLICATIONS

4V to 36V_{IN}/200V_{OUT} Isolated Flyback Converter

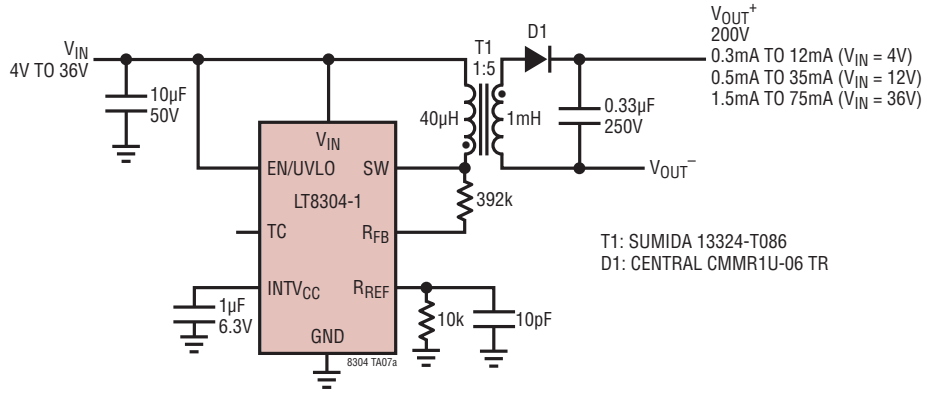

Efficiency, $V_{OUT} = 200V$

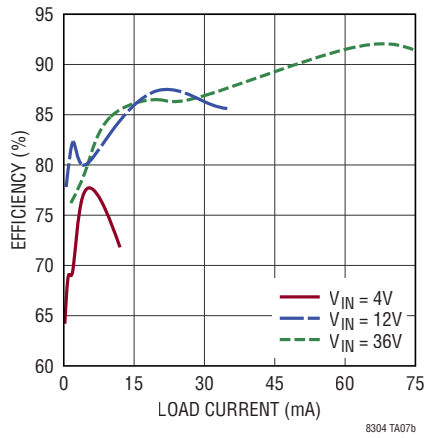

Load Regulation, $V_{OUT} = 200V$

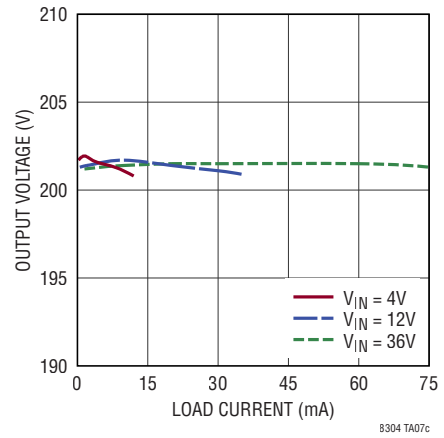

4V to 18V_{IN}/400V_{OUT} Isolated Flyback Converter

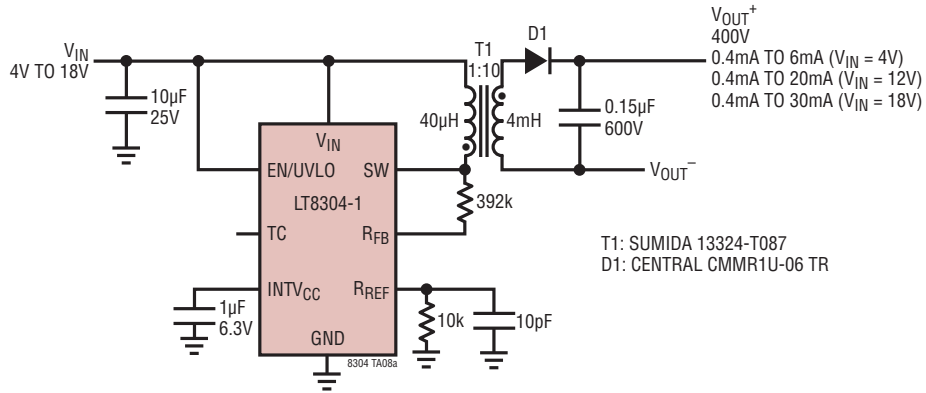

Efficiency, V_{OUT} = 400V

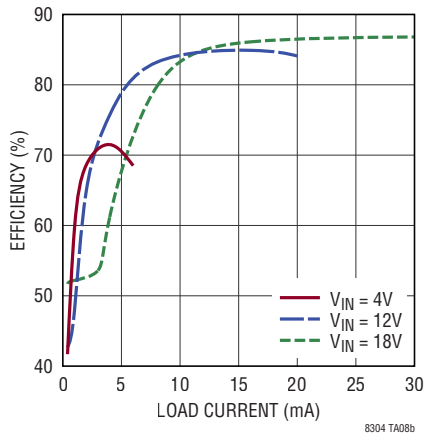

Load Regulation, V_{OUT} = 400V

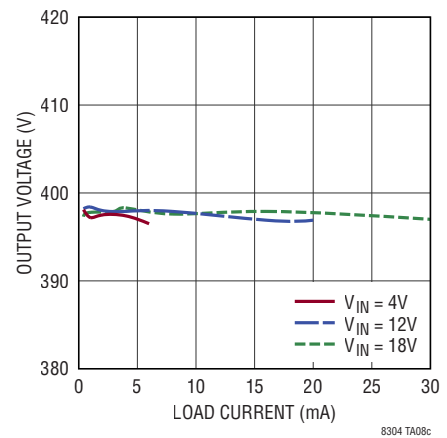

TYPICAL APPLICATIONS

-4V to -80V_{IN}/12V_{OUT} Buck-Boost Converter

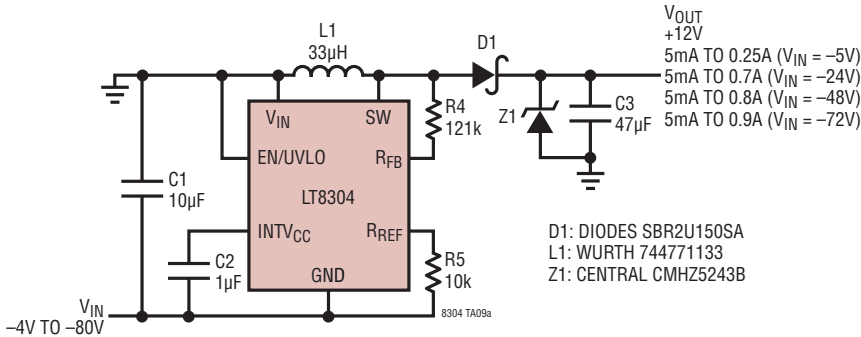

Efficiency vs Load Current

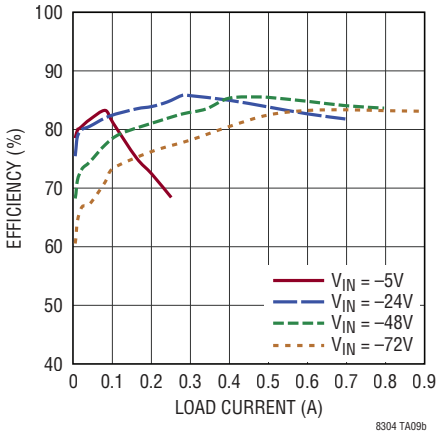

-18V to -80V_{IN}/-12V_{OUT} Negative Buck Converter

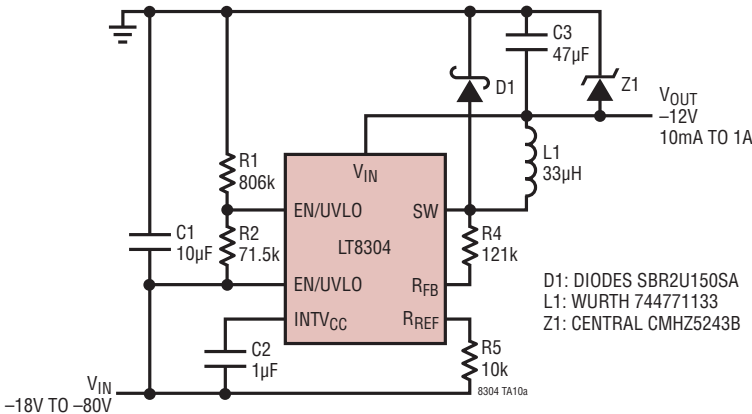

Efficiency vs Load Current

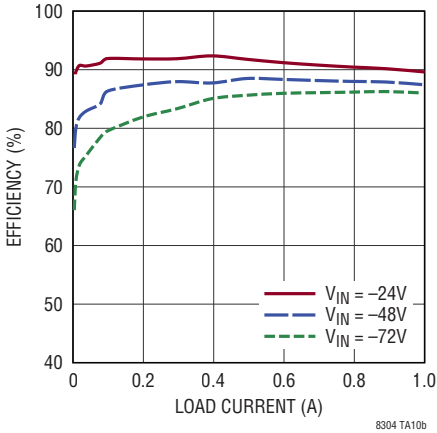

PACKAGE DESCRIPTION

Please refer to <http://www.linear.com/product/LT8304#packaging> for the most recent package drawings.

S8E Package 8-Lead Plastic SOIC (Narrow .150 Inch) Exposed Pad (Reference LTC DWG # 05-08-1857 Rev C)

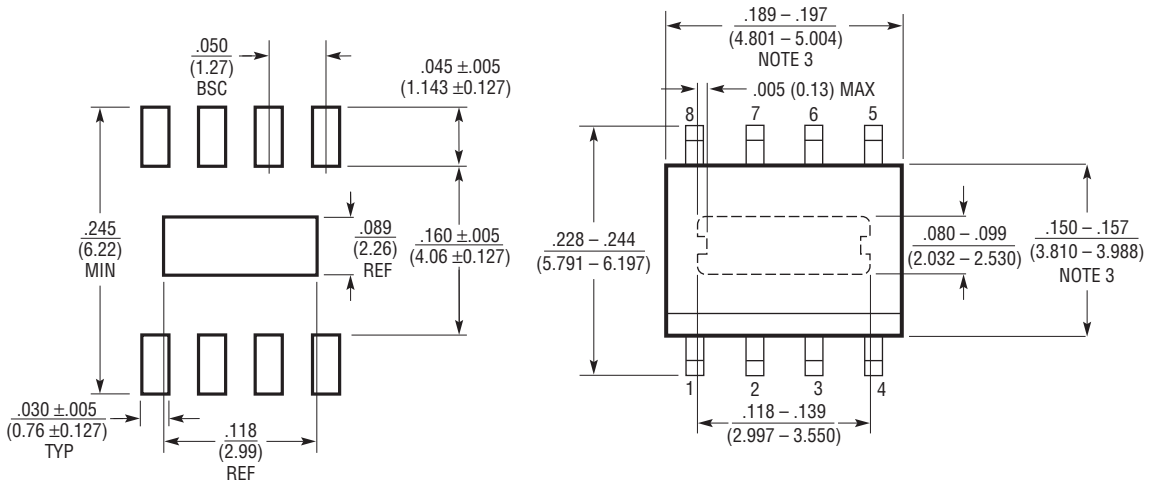

RECOMMENDED SOLDER PAD LAYOUT

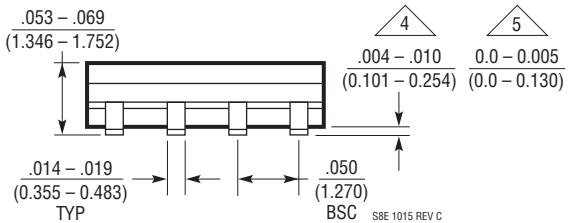
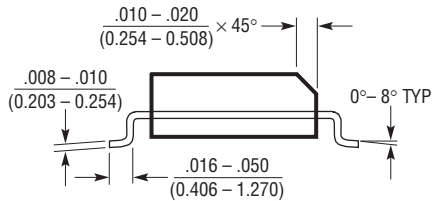

- NOTE:
 1. DIMENSIONS IN INCHES (MILLIMETERS)
 2. DRAWING NOT TO SCALE
 3. THESE DIMENSIONS DO NOT INCLUDE MOLD FLASH OR PROTRUSIONS. MOLD FLASH OR PROTRUSIONS SHALL NOT EXCEED .010" (0.254mm)

4. STANDARD LEAD STANDOFF IS 4mils TO 10mils (DATE CODE BEFORE 542)
 5. LOWER LEAD STANDOFF IS 0mils TO 5mils (DATE CODE AFTER 542)

REVISION HISTORY

REV	DATE	DESCRIPTION	PAGE NUMBER
A	02/17	Added LT8304-1 and H-Grade options Changed TC Pin Current conditions Changed TC pin description to °C Added High Step-Up V_{OUT} Applications section Updated Predesigned Transformers – Typical Specifications table Revised Turns Ratio section Added new application circuits and graphs	All 3 7 9 13 14 23, 24

TYPICAL APPLICATION

4V to 100V_{IN}/140V_{OUT} Boost Converter

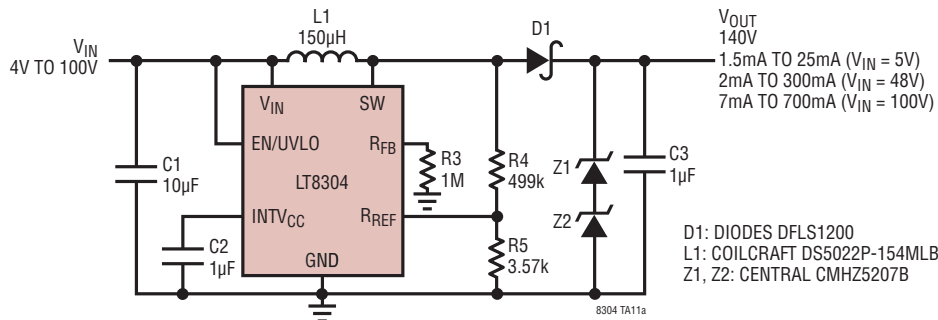

Efficiency vs Load Current

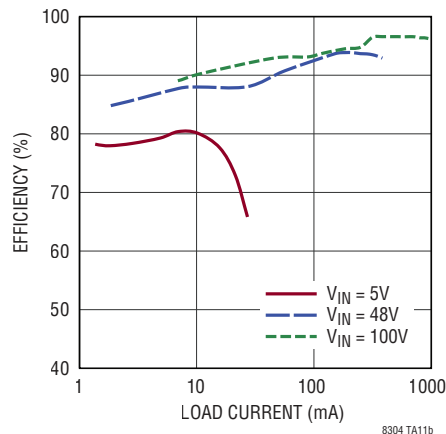

RELATED PARTS

PART NUMBER	DESCRIPTION	COMMENTS
LT8300	100V _{IN} Micropower Isolated Flyback Converter with 150V/260mA Switch	Low I _Q Monolithic No-Opto Flyback, 5-Lead TSOT-23
LT8301	42V _{IN} Micropower Isolated Flyback Converter with 65V/1.2A Switch	Low I _Q Monolithic No-Opto Flyback, 5-Lead TSOT-23
LT8302	42V _{IN} Micropower Isolated Flyback Converter with 65V/3.6A Switch	Low I _Q Monolithic No-Opto Flyback, 8-Lead SO-8E
LT8303	100V _{IN} Micropower Isolated Flyback Converter with 150V/450mA Switch	Low I _Q Monolithic No-Opto Flyback, 5-Lead TSOT-23
LT8309	Secondary-Side Synchronous Rectifier Driver	4.5V ≤ V _{CC} ≤ 40V, Fast Turn-On and Turn-Off, 5-Lead TSOT-23
LT3573/LT3574 LT3575	40V Isolated Flyback Converters	Monolithic No-Opto Flybacks with Integrated 1.25A/0.65A/2.5A Switch
LT3511/LT3512	100V Isolated Flyback Converters	Monolithic No-Opto Flybacks with Integrated 240mA/420mA Switch, MSOP-16(12)
LT3748	100V Isolated Flyback Controller	5V ≤ V _{IN} ≤ 100V, No-Opto Flyback, MSOP-16(12)
LT3798	Off-Line Isolated No-Opto Flyback Controller with Active PFC	V _{IN} and V _{OUT} Limited Only by External Components
LT3757A/LT3759/ LT3758	40V/100V Flyback/Boost Controllers	Universal Controllers with Small Package and Powerful Gate Drive
LT3957/LT3958	40V/80V Boost/Flyback Converters	Monolithic with Integrated 5A/3.3A Switch

8304fa

Looking for pricing, stock, or lifecycle information?

Click below to explore more details on WIN SOURCE:

 [View LT8304ES8E#PBF on WIN SOURCE](#)

 [Analog Devices Inc. Information](#)

Optimize Your Supply Chain with WIN SOURCE Solutions

-  Global Sourcing Solution
-  Obsolete Management
-  Cost Control Management
-  Shortage Management
-  Alternative Solution
-  Excess Inventory Management