



**THE DATASHEET OF  
SI3401-D-GM**



## FULLY-INTEGRATED 802.3-COMPLIANT PD INTERFACE AND SWITCHING REGULATOR

### Features

- IEEE 802.3 standard-compliant solution, including pre-standard (legacy) PoE support
- Highly-integrated IC enables compact solution footprints
  - Minimal external components
  - Integrated diode bridges and transient surge suppressor
  - Integrated switching regulator controller with on-chip power FET
  - Integrated dual current-limited hotswap switch
- Support non-isolated and isolated switching topologies
- Comprehensive protection circuitry
  - Transient overvoltage protection
  - Undervoltage lockout
  - Early power-loss indicator
  - Thermal shutdown protection
  - Foldback current limiting
- Programmable classification circuit
- Low-profile 5 x 5 mm 20-pin QFN
- Pb-Free and RoHS-compliant

### Applications

- Voice over IP telephones and adapters
- Wireless access points
- Security cameras
- Point-of-sale terminals
- Internet appliances
- Network devices
- High power applications (Si3401)

### Description

The Si3400 and Si3401 integrate all power management and control functions required in a Power-over-Ethernet (PoE) powered device (PD) application. The Si3400 and Si3401 convert the high voltage supplied over the 10/100/1000BASE-T Ethernet connection into a regulated, low-voltage output supply. The optimized architectures of the Si3400 and Si3401 minimize the solution footprint, reduce external BOM cost, and enable the use of low-cost external components while maintaining high performance. The Si3400 and Si3401 integrate the required diode bridges and transient surge suppressors, thus enabling direct connection of ICs to the Ethernet RJ-45 connector. The switching power FET and all associated functions are also integrated. The integrated switching regulator supports isolated (flyback) and non-isolated (buck) converter topologies. The Si3400 and Si3401 support IEEE STD™ 802.3-2005 (future instances are referred to as 802.3) compliant solutions as well as pre-standard products, all in a single IC. Standard external resistors connected to the Si3400 and Si3401 provide the proper 802.3 signatures for the detection function and programming of the classification mode. Startup circuits ensure well-controlled initial operation of both the hotswap switch and the voltage regulator. The Si3400 and Si3401 are available in low-profile, 20-pin, 5 x 5 mm QFN packages. While the Si3400 is designed for applications up to 10 W, the Si3401 is optimized for higher power applications (up to approximately 15 W). See also “AN313: Using the Si3400/01 in High Power Applications” for more information.

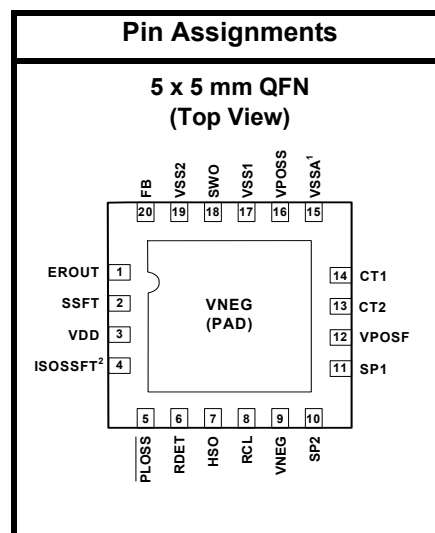

#### Notes:

1. Pin VSSA added on revisions CZ and higher.
2. Pin ISOSSFT added on revisions CZ and higher. Function available on revision E silicon. For Rev CZ, or to disable this feature on Revision E, tie this pin to VDD.



---

**TABLE OF CONTENTS**

---

<b><u>Section</u></b>	<b><u>Page</u></b>
<b>1. Electrical Specifications</b> .....	<b>4</b>
<b>2. Typical Application Schematics</b> .....	<b>8</b>
<b>3. Functional Description</b> .....	<b>10</b>
3.1. Overview .....	10
3.2. PD Hotswap Controller .....	10
3.3. Switching Regulator .....	13
<b>4. Pin Descriptions</b> .....	<b>15</b>
<b>5. Package Outline</b> .....	<b>16</b>
<b>6. Ordering Guide</b> .....	<b>17</b>
<b>Document Change List</b> .....	<b>18</b>
<b>Contact Information</b> .....	<b>20</b>

# Si3400/Si3401

## 1. Electrical Specifications

**Table 1. Absolute Maximum Ratings (DC)<sup>1</sup>**

Type	Description	Rating	Unit
Voltage	CT1 to CT2	-60 to 60	V
	SP1 to SP2	-60 to 60	
	VPOS <sup>2</sup>	-0.3 to 60	
	HSO	-0.3 to 60	
	VSS1 or VSS2	-0.3 to 60	
	SWO	-0.3 to 60	
	PLOSS to VPOS <sup>2</sup>	-60 to 0.3	
	RDET	-0.3 to 60	
	RCL	-0.3 to 5	
	SSFT to VPOS <sup>2</sup>	-5 to 0.3	
	EROUT to VSS1, VSS2, or VSSA	-0.3 to VDD+0.3	
	FB to VPOS	-5 to 0.3	
	RIMAX to VSS1, VSS2, or VSSA	-0.3 to VDD+0.3	
	VSS1 to VSS2 or VSSA	-0.3 to 0.3	
VDD to VSS1, VSS2, or VSSA	-0.3 to 5		
Current	RCL	0 to 100	mA
	RDET	0 to 1	
	CT1, CT2, SP1, SP2	-400 to 400	
	VPOS <sup>2</sup>	-400 to 400	
	HSO	0 to 400	
	PLOSS	-0.5 to 5	
	VDD	0 to 2	
	SWO	0 to 400	
	VSS1, VSS2, or VSSA	-400 to 0	
Ambient Temperature	Storage	-65 to 150	°C
	Operating	-40 to 85	

**Notes:**

1. Unless otherwise noted, all voltages referenced to VNEG. Permanent device damage may occur if the maximum ratings are exceeded. Functional operation should be restricted to those conditions specified in the operational sections of this data sheet. Exposure to absolute maximum rating conditions for extended periods may adversely affect device reliability.
2. VPOS is equal to VPOSF and VPOSS tied together for test condition purposes.

**Table 2. Absolute Maximum Ratings (Transient)<sup>1</sup>**

Transient surge defined in IEC60060 as a 1000 V impulse of either polarity applied across CT1–CT2 or SP1–SP2. The shape of the impulse shall have a 300 ns full rise time and a 50  $\mu$ s half fall time, with 201  $\Omega$  source impedance.

Type	Description	Rating	Unit
Voltage	CT1 to CT2	–82 to 82	V
	SP1 to SP2	–82 to 82	
	VPOS <sup>2</sup>	–0.7 to 80	
	HSO	–0.7 to 80	
	VSS1, VSS2, or VSSA	–0.7 to 80	
	SWO	–0.7 to 80	
	PLOSS to VPOS <sup>2</sup>	–80 to 0.7	
	RDET	–0.7 to 80	
Current	CT1, CT2, SP1, SP2	–5 to 5	A
	VPOS <sup>2</sup>	–5 to 5	
ESD <sup>3</sup>	HBM, all pins	–2 to 2	kV

**Notes:**

1. Unless otherwise noted, all voltages referenced to VNEG. Permanent device damage may occur if the maximum ratings are exceeded. Functional operation should be restricted to those conditions specified in the operational sections of this data sheet. Exposure to absolute maximum rating conditions for extended periods may adversely affect device reliability.
2. VPOS is equal to VPOSF and VPOSS tied together for test condition purposes.
3. For more information regarding system-level ESD tolerance, refer to “AN315: Robust Electrical Surge Immunity for PoE PDs through Integrated Protection”.

**Table 3. Recommended Operating Conditions**

Description	Symbol	Min	Typ	Max	Units
CT1 – CT2  or  SP1 – SP2	VPORT	2.8	—	57	V
Ambient Operating Temperature	TA	–40	25	85	°C

**Note:** Unless otherwise noted, all voltages referenced to VNEG. All minimum and maximum specifications are guaranteed and apply across the recommended operating conditions. Typical values apply at nominal supply voltage and ambient temperature unless otherwise noted.

**Table 4. Electrical Characteristics**

Parameter	Description	Min	Typ	Max	Unit
VPORT	Detection	2.7	—	11	V
	Classification	14	—	22	
	UVLO Turn Off	—	—	42	
	UVLO Turn On	30	—	36	
	Transient Surge <sup>1</sup>	62	—	79	
Input Offset Current	VPORT < 10 V	—	—	10	μA
Diode bridge leakage	VPORT = 57 V	—	—	25	μA
IPOINT Classification <sup>2</sup>	Class 0	0	—	4	mA
	Class 1	9	—	12	
	Class 2	17	—	20	
	Class 3	26	—	30	
	Class 4	36	—	44	
IPOINT Operating Current <sup>3</sup>	36 V ≤ VPORT ≤ 57 V	—	2	3.1	mA
Current Limit <sup>4</sup>	Inrush	—	130	—	mA
	Operating	350 (Si3400) 470 (Si3401)	525 550	—	mA
Hotswap FET On-Resistance + R <sub>SENSE</sub>	36 V ≤ VPORT ≤ 57 V	0.5	—	1.4	Ω
Power loss VPORT Threshold		27	30	33	V
Switcher Frequency		—	350	—	kHz
Maximum Switcher Duty Cycle <sup>5</sup>	ISOSSFT connected to VDD	—	50	—	%
Switching FET On-Resistance		0.3	—	0.86	Ω
Regulated Feedback @ pin FB <sup>6</sup>	DC Avg.	—	1.23	—	V
Regulated Output Voltage Tolerance <sup>6</sup>	Output voltage tolerance @ VOUT	–5	—	5	%

**Notes:**

1. Transient surge defined in IEC60060 as a 1000 V impulse of either polarity applied to CT1–CT2 or SP1–SP2. The shape of the impulse shall have a 300 ns full rise time and a 50 μs half fall time with 201 Ω source impedance.
2. The classification currents are guaranteed only when recommended RCLASS resistors are used, as specified in Table 10.
3. IPOINT includes full operating current of switching regulator controller.
4. The PD interface includes dual-level input current limit. At turn-on, before the HSO load capacitor is charged, the current limit is set at the inrush level. After the capacitor has been charged within ~1.25 V of VNEG, the operating current limit is engaged. This higher current limit remains active until the UVLO lower limit has been tripped or until the hotswap switch is sufficiently current-limited to cause a foldback of the HSO voltage.
5. See “AN296: Using the Si3400/01 PoE PD Controller in Isolated and Non-Isolated Designs” for more information.
6. Applies to non-isolated applications only (VOUT on schematic in Figure 1).

Table 4. Electrical Characteristics (Continued)

Parameter	Description	Min	Typ	Max	Unit
VDD accuracy @ 0.8 mA	$36\text{ V} \leq V_{\text{PORT}} \leq 57\text{ V}$	4.5	—	5.5	V
Softstart charging current		—	12	—	$\mu\text{A}$
Thermal Shutdown	Junction temperature	—	160	—	$^{\circ}\text{C}$
Thermal Shutdown Hysteresis		—	—	25	$^{\circ}\text{C}$

**Notes:**

1. Transient surge defined in IEC60060 as a 1000 V impulse of either polarity applied to CT1–CT2 or SP1–SP2. The shape of the impulse shall have a 300 ns full rise time and a 50  $\mu\text{s}$  half fall time with 201  $\Omega$  source impedance.
2. The classification currents are guaranteed only when recommended RCLASS resistors are used, as specified in Table 10.
3. IPORT includes full operating current of switching regulator controller.
4. The PD interface includes dual-level input current limit. At turn-on, before the HSO load capacitor is charged, the current limit is set at the inrush level. After the capacitor has been charged within  $\sim 1.25\text{ V}$  of VNEG, the operating current limit is engaged. This higher current limit remains active until the UVLO lower limit has been tripped or until the hotswap switch is sufficiently current-limited to cause a foldback of the HSO voltage.
5. See “AN296: Using the Si3400/01 PoE PD Controller in Isolated and Non-Isolated Designs” for more information.
6. Applies to non-isolated applications only (VOUT on schematic in Figure 1).

Table 5. Total Power Dissipation

Description	Condition	Min	Typ	Max	Units
Power Dissipation	$V_{\text{PORT}} = 50\text{ V}$ , $V_{\text{OUT}} = 5\text{ V}$ , 2 A	—	1.2	—	W
Power Dissipation*	$V_{\text{PORT}} = 50\text{ V}$ , $V_{\text{OUT}} = 5\text{ V}$ , 2 A w/ diode bridges bypassed	—	0.7	—	W

**\*Note:** Silicon Laboratories recommends the on-chip diode bridges be bypassed when output power requirements are  $>10\text{ W}$  (Si3401) or in thermally-constrained applications. For more information, see “AN313: Using the Si3400 and Si3401 in High Power Applications”.

Table 6. Package Thermal Characteristics

Parameter	Symbol	Test Condition	Typ	Units
Thermal resistance (junction to ambient)	$\theta_{\text{JA}}$	Still air; assumes a minimum of nine thermal vias are connected to a 2 in <sup>2</sup> heat spreader plane for the package “pad” node (VNEG).	44	$^{\circ}\text{C}/\text{W}$

## 2. Typical Application Schematics

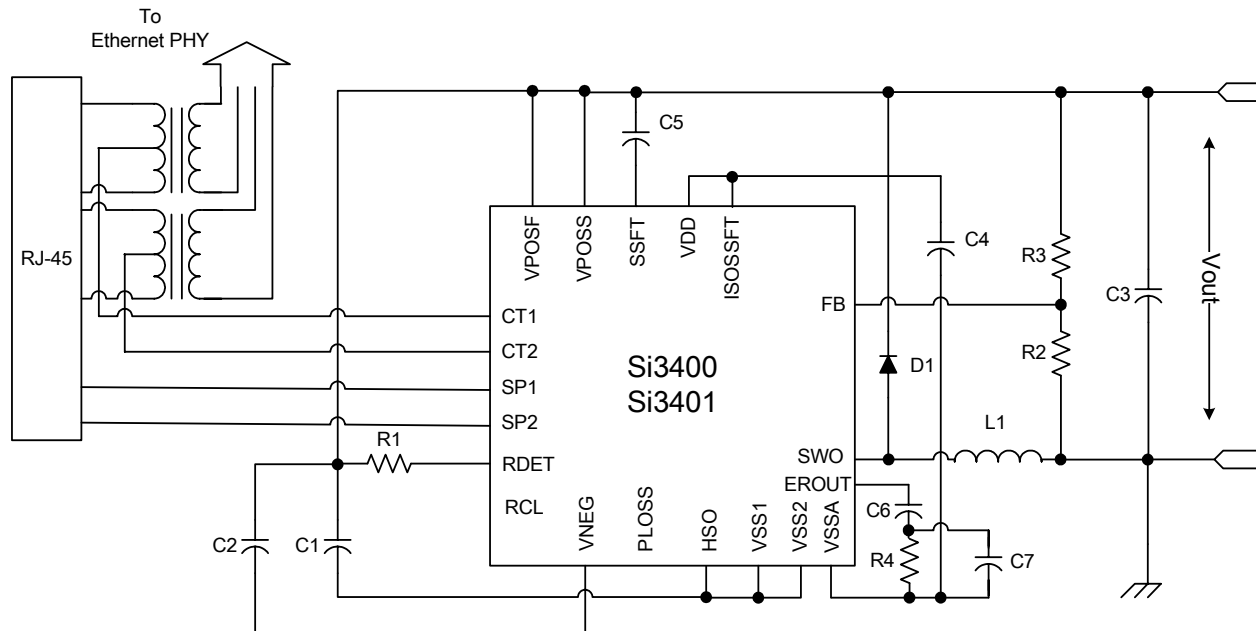
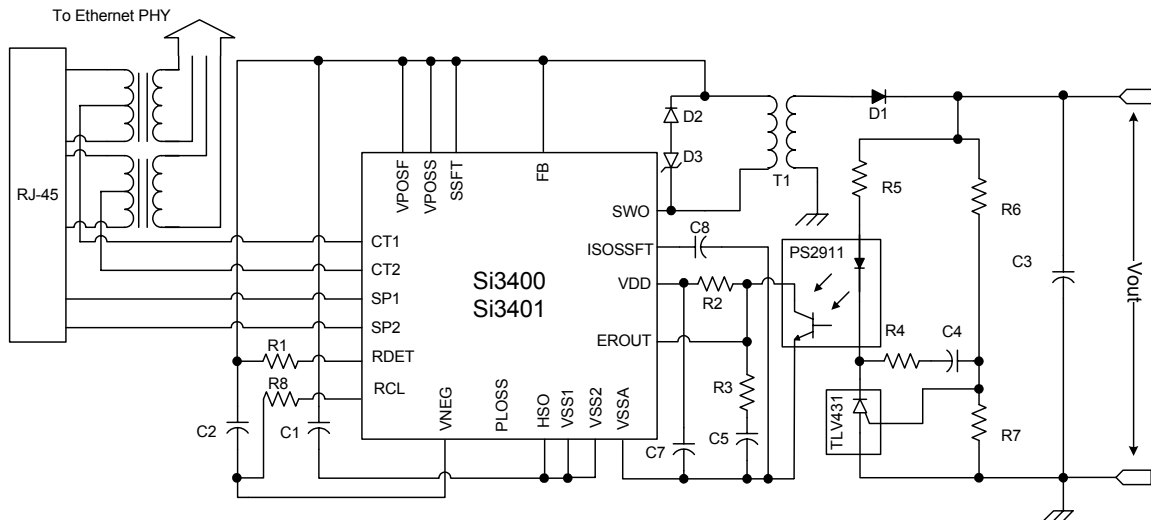

**Figure 1. Schematic—Class 0 with Non-Isolated 5 V Output\***

**\*Note:** This is a simplified schematic. See “AN296: Using the Si3400/01 PoE PD Controller in Isolated and Non-Isolated Designs” for more details and complete application schematics.

**Table 7. Component Listing—Class 0 with 5 V Output**

Item	Type	Value	Toler.	Rating	Notes
C1	Capacitor	15 $\mu$ F	20%	100 V	Switcher supply capacitor. Several parallel capacitors are used for lower ESR.
C2	Capacitor	0.1 $\mu$ F	20%	100 V	PD input supply capacitor.
C3	Capacitor	1000 $\mu$ F	20%	10 V	Switcher load capacitor - 1000 $\mu$ F in parallel with and X5R 22 $\mu$ F for lower ESR.
C4	Capacitor	0.1 $\mu$ F	20%	16 V	VDD bypass capacitor.
C5	Capacitor	0.1 $\mu$ F	10%	16 V	Softstart capacitor.
C6	Capacitor	3.3 nF	10%	16 V	Compensation capacitor.
C7	Capacitor	150 pF	10%	16 V	Compensation capacitor.
R1	Resistor	25.5 k $\Omega$	1%	1/16 W	Detection resistor.
R2	Resistor	7.32 k $\Omega$	1%	1/16 W	Feedback resistor divider.
R3	Resistor	2.87 k $\Omega$	1%	1/16 W	Feedback resistor divider.
R4	Resistor	30.1 k $\Omega$	1%	1/16 W	Feedback compensation resistor.
D1	Diode			100 V	Schottky diode; part no. PDS5100.
L1	Inductor	33 $\mu$ H	20%	3.5 A	Coilcraft part no. DO5010333.



**Figure 2. Schematic—Class 1 with Isolated 5.0 V Output\***

**\*Note:** This is a simplified schematic. See “AN296: Using the Si3400/01 PoE PD Controller in Isolated and Non-Isolated Designs” for more details and complete application schematics.

**Table 8. Components—Class 1 with Isolated 5.0 V Output**

Item	Type	Value	Toler.	Rating	Notes
C1	Capacitor	15 $\mu$ F	20%	100 V	Switcher supply capacitor. Several parallel capacitors are used for lower ESR.
C2	Capacitor	0.1 $\mu$ F	20%	100 V	PD input supply capacitor.
C3	Capacitor	1100 $\mu$ F	20%	10 V	Switcher load capacitor. 100 $\mu$ F in parallel 1000 $\mu$ F and optional 1 $\mu$ H inductor for additional filtering.
C4	Capacitor	15 nF	10%	16 V	Feedback compensation.
C5	Capacitor	220 nF	10%	16 V	Feedback compensation.
C7	Capacitor	0.1 $\mu$ F	20%	16 V	VDD bypass capacitor.
C8	Capacitor	1 $\mu$ F	20%	16 V	Isolated mode soft start (tie ISOSSFT to VDD if this feature is not used).
R1	Resistor	25.5 k $\Omega$	1%	1/16 W	Detection resistor.
R2	Resistor	4.99 k $\Omega$	1%	1/16 W	Pull-up resistor.
R3	Resistor	100 $\Omega$	1%	1/16 W	Feedback compensation resistor.
R4	Resistor	10 k $\Omega$	1%	1/16 W	Feedback compensation resistor.
R5	Resistor	2.05 k $\Omega$	1%	1/16 W	Pull-up resistor.
R6	Resistor	36.5 k $\Omega$	1%	1/16 W	Feedback resistor divider.
R7	Resistor	12.1 k $\Omega$	1%	1/16 W	Feedback resistor divider.
R8	Resistor	127 $\Omega$	1%	1/16 W	Classification resistor.
D1	Diode	10 A		40 V	Schottky diode; part no. PN PDS1040.
D2	Diode	1 A		100 V	Snubber diode (1N4148)
D3	Diode	15 V		9 A	Snubber diode (DFLT15A)
T1	Transformer	40 $\mu$ H			Coilcraft part number FA2672 (5 V).
PS2911	Optocoupler				
TLV431	Voltage reference				

## 3. Functional Description

The Si3400 and Si3401 consist of two major functions: a hotswap controller/interface and a complete pulse-width-modulated switching regulator (controller and power FET).

### 3.1. Overview

The hotswap interfaces of the Si3400 and Si3401 provide the complete front end of an 802.3-compliant PD. The Si3400 and Si3401 also include two full diode bridges, a transient voltage surge suppressor, detection circuit, classification current source, and dual-level hotswap current limiting switch. This high level of integration enables direct connection to the RJ-45 connector, simplifies system design, and provides significant advantages for reliability and protection. The Si3400 and Si3401 require only four standard external components (detection resistor, optional classification resistor, load capacitor, and input capacitor) to create a fully 802.3-compliant interface. For more information about supporting higher-power applications, see “AN313: Using the Si3400 and Si3401 in High Power Applications” and “AN314: Power Combining Circuit for PoE for up to 18.5 W Output”.

The Si3400 and Si3401 integrate a complete pulse-width modulated switching regulator that includes the controller and power FET. The switching regulator utilizes a constant frequency pulse-width modulated controller optimized for all possible load conditions in PoE applications. The regulator integrates a low on-resistance ( $R_{on}$ ) switching power MOSFET that minimizes power dissipation, increases overall regulator efficiency, and simplifies system design. An integrated error amplifier, precision reference, and programmable soft-start current source provide the flexibility of using a non-isolated buck regulator topology or an isolated flyback regulator topology.

The Si3400 and Si3401 are designed to operate with both 802.3-compliant Power Sourcing Equipment (PSE) and pre-standard (legacy) PSEs that do not adhere to the 802.3 specified inrush current limits. The Si3400 and Si3401 are compatible with compliant and legacy PSEs because they use two levels for the hotswap current limits. By setting the initial inrush current limit to a low level, a PD based on the Si3400 or Si3401 minimizes the current drawn from either a compliant or legacy PSE during startup. After powering up, the Si3400 and Si3401 automatically switch to a higher-level current limit, thereby allowing the PD to consume up to 12.95 W (the max power allowed by the 802.3 specification).

The inrush current limit specified by the 802.3 standard can generate high transient power dissipation in the PD. By properly sizing the devices and implementing on-chip thermal protection, the Si3400 and Si3401 can go through multiple turn-on sequences without overheating the package or damaging the device. The switching regulator power MOSFET has been conservatively designed and sized to withstand the high peak currents created when converting a high-voltage, low-current supply into a low-voltage, high-current supply. Excessive power cycling or short circuit faults will engage the thermal overload protection to prevent the onboard power MOSFETs from exceeding their safe and reliable operating ranges.

### 3.2. PD Hotswap Controller

The Si3400 and Si3401 hotswap controllers change their mode of operation based on the input voltage applied to the CT1 and CT2 pins or the SP1 and SP2 pins, the 802.3-defined modes of operation, and internal controller requirements. Table 9 defines the modes of operation for the hotswap interface.

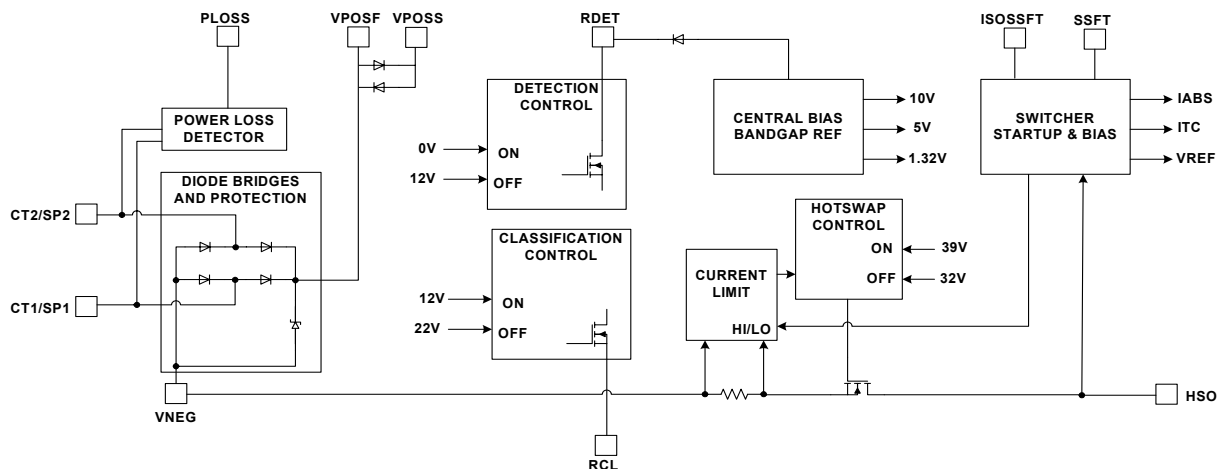

Figure 3. Hotswap Block Diagram

Table 9. Hotswap Interface Modes

Input Voltage ( CT1-CT2  or  SP1-SP2 )	Si3400 and Si3401 Mode
0 V to 2.7 V	Inactive
2.7 V to 11 V	Detection signature
11 V to 14 V	Detection turns off and internal bias starts
14 V to 22 V	Classification signature
22 V to 42 V	Transition region
42 V up to 57 V	Switcher operating mode (hysteresis limit based on rising input voltage)
57 V down to 36 V	Switcher operating mode (hysteresis limit based on falling input voltage)

### 3.2.1. Rectification Diode Bridges and Surge Suppressor

The 802.3 specification defines the input voltage at the RJ-45 connector of the PD with no reference to polarity. In other words, the PD must be able to accept power of either polarity at each of its inputs. This requirement necessitates the use of two sets of diode bridges, one for the CT1 and CT2 pins and one for the SP1 and SP2 pins to rectify the voltage. Furthermore, the standard requires that a PD withstand a high-voltage transient surge consisting of a 1000 V common-mode impulse with 300 ns rise time and 50  $\mu$ s half fall time. Typically, the diode bridge and the surge suppressor have been implemented externally, adding cost and complexity to the PD system design.

The diode bridge\* and the surge suppressor have been integrated into the Si3400 and Si3401, thus reducing system cost and design complexity.

**\*Note:** Silicon Laboratories recommends that on-chip diode bridges be bypassed when >10 W of output power is required.

By integrating the diode bridges, the Si3400 and Si3401 gain access to the input side of the diode bridge. Monitoring the voltage at the input of the diode bridges instead of the voltage across the load capacitor provides the earliest indication of a power loss. This true early power loss indicator, PLOSS, provides a local microcontroller time to save states and shut down gracefully before the load capacitor discharges below the minimum 802.3-specified operating voltage of 36 V. Integration of the surge suppressor enables optimization of the clamping voltage and guarantees protection of all connected circuitry.

As an added benefit, the transient surge suppressor, when tripped, actively disables the hotswap interface and switching regulator, preventing downstream circuits from encountering the high-energy transients.

### 3.2.2. Detection

In order to identify a device as a valid PD, a PSE will apply a voltage in the range of 2.8 V to 10 V on the cable and look for the 25.5 k $\Omega$  signature resistor. The Si3400 and Si3401 will react to voltages in this range by connecting an external 25.5 k $\Omega$  resistor between VPOS and VNEG. This external resistor and internal low-leakage control circuitry create the proper signature to alert the PSE that a valid PD has been detected and is ready to have power applied. The internal hotswap switch is disabled during this time to prevent the switching regulator and attached load circuitry from generating errors in the detection signature.

Since the Si3400 and Si3401 integrate the diode bridges, the IC can compensate for the voltage and resistance effects of the diode bridges. The 802.3 specification requires that the PSE use a multi-point,  $\Delta V/\Delta I$  measurement technique to remove the diode-induced dc offset from the signature resistance measurement. However, the specification does not address the diode's nonlinear resistance and the error induced in the signature resistor measurement. Since the diode's resistance appears in series with the signature resistor, the PD system must find some way of compensating for this error. In systems where the diode bridges are external, compensation is difficult and suffers from errors. Since the diode bridges are integrated in the Si3400 and Si3401, the IC can easily compensate for this error by offsetting resistance across all operating conditions and thus meeting the 802.3 requirements. An added benefit is that this function can be tested during the IC's automated testing step, guaranteeing system compliance when used in the final PD application. For more information about supporting higher-power applications (above 12.95 W), see "AN313: Using the Si3400 and Si3401 in High Power Applications" and "AN314: Power Combining Circuit for PoE for up to 18.5 W Output".

### 3.2.3. Classification

Once the PSE has detected a valid PD, the PSE may classify the PD for one of five power levels or classes. A class is based on the expected power consumption of the powered device. An external resistor sets the nominal class current that can then be read by the PSE to determine the proper power requirements of the PD.

When the PSE presents a fixed voltage  $V$  between 15.5 V and 20.5 V to the PD, the Si3400 and Si3401 assert the class current from VPOS through the RCL resistor.

# Si3400/Si3401

The resistor values associated with each class are shown in Table 10.

**Table 10. Class Resistor Values**

Class	Usage	Power Levels	Nominal Class Current	RCL Resistor (1%, 1/16 W)
0	Default	0.44 W to 12.95 W	< 4 mA	> 1.33 k $\Omega$ (or open circuit)
1	Optional	0.44 W to 3.84 W	10.5 mA	127 $\Omega$
2	Optional	3.84 W to 6.49 W	18.5 mA	69.8 $\Omega$
3	Optional	6.49 W to 12.95 W	28 mA	45.3 $\Omega$
4	Reserved	Reserved	40 mA	30.9 $\Omega$

The 802.3 specification limits the classification time to 75 ms to limit the power dissipated in the PD. If the PSE classification period exceeds 75 ms and the die temperature rises above the thermal shutdown limits, the thermal protection circuit will engage and disable the classification current source in order to protect the Si3400 and Si3401. The Si3400 and Si3401 stay in classification mode until the input voltage exceeds 22 V (the upper end of its classification operation region).

### 3.2.4. Under Voltage Lockout

The 802.3 standard specifies the PD to turn on when the line voltage rises to 42 V and for the PD to turn off when the line voltage falls to 30 V. The PD must also maintain a large on-off hysteresis region to prevent wiring losses between the PSE and the PD from causing startup oscillation.

The Si3400 and Si3401 incorporate an undervoltage lockout (UVLO) circuit to monitor the line voltage and determine when to apply power to the integrated switching regulator. Before the power is applied to the switching regulator, the hotswap switch output (HSO) pin is high-impedance and typically follows VPOS as the input is ramped (due to the discharged switcher supply capacitor). When the input voltage rises above the UVLO turn-on threshold, the Si3400 and Si3401 begin to turn on the internal hotswap power MOSFET. The switcher supply capacitor begins to charge up under the current limit control of the Si3400 and Si3401, and the HSO pin transitions from VPOS to VNEG. The Si3400 and Si3401 include hysteretic UVLO circuits to maintain power to the load until the input voltage falls below the UVLO turn-off threshold. Once the input voltage falls below 30 V, the internal hotswap MOSFET is turned off.

### 3.2.5. Dual Current Limit and Switcher Turn-On

The Si3400 and Si3401 implement dual current limits. While the hotswap MOSFET is charging the switcher supply capacitor, the Si3400 and Si3401 maintain a low current limit. The switching regulator is disabled until the voltage across the hotswap MOSFET becomes sufficiently low, indicating the switcher supply capacitor is almost completely charged. When this threshold is reached, the switcher is activated, and the hotswap current limit is increased. This threshold also has hysteresis to prevent systemic oscillation as the switcher begins to draw current and the current limit is increased, which allows resistive losses in the cable to effectively decrease the input supply.

The Si3400 and Si3401 stay in a high-level current limit mode until the input voltage drops below the UVLO turn-off threshold or excessive power is dissipated in the hotswap switch. This dual level current limit allows the system designer to design powered devices for use with both legacy and compliant PoE systems.

An additional feature of the dual current limit circuitry is foldback current limiting in the event of a fault condition. When the current limit is switched to the higher level, 400 mA of current can be drawn by the PD. Should a fault cause more than this current to be consumed, the voltage across the hotswap MOSFET will increase to clamp the maximum amount of power consumed. The power dissipated by the MOSFET can be very high under this condition. If the fault is very low impedance, the voltage across the hotswap MOSFET will continue to rise until the lower current limit level is engaged, further reducing the dissipated power. If the fault condition remains, the thermal overload protection circuitry will eventually engage and shut down the hotswap interface and switching regulator. The foldback current limiting occurs much faster than the thermal overload protection and is, therefore, necessary for comprehensive protection of the hotswap MOSFET.

### 3.2.6. Power Loss Indicator

A situation can occur in which power is lost at the input of the diode bridge and the hotswap controller does not detect the fault due to the VPOS to VNEG capacitor maintaining the voltage. In such a situation, the PD can remain operational for hundreds of microseconds despite the PSE having removed the line voltage. If it is recognized early enough, the time from power loss to power failure can provide valuable time to gracefully shut down an application.

Due to integration of the diode bridges, the Si3400 and Si3401 are able to instantaneously detect the removal of the line voltage and provide that early warning signal to the PD application. The  $\overline{\text{PLOSS}}$  pin is an open drain output that pulls up to VPOS when a line voltage greater than 27 V is applied. When the line voltage falls below 27 V, the output becomes high-impedance, allowing an external pull-down resistor to change the logic state of PLOSS. The benefit of this indicator is that the powered device may include a microcontroller that can quickly save its memory or operational state before draining the supply capacitors and powering itself down. This feature can help improve overall manageability in applications, such as wireless access points.

### 3.3. Switching Regulator

Power over Ethernet (PoE) applications fall into two broad categories, isolated and non-isolated. Non-isolated systems can be used when the powered device is self-contained and does not provide external conductors to the user or another application. Non-isolated applications include wireless access points and

security cameras. In these applications, there is no explicit need for dc isolation between the switching regulator output and the hotswap interface. An isolated system must be used when the powered device interfaces with other self-powered equipment or has external conductors accessible to the user or other applications. For proper operation, the regulated output supply of the switching regulator must not have a dc electrical path to the hotswap interface or switching regulator primary side. Isolated applications include point-of-sale terminals where the user can touch the grounded metal chassis.

The application determines the converter topology. An isolated application will require a flyback transformer-based switching topology while a non-isolated application can use an inductor-based buck converter topology. In the isolated case, dc isolation is achieved through a transformer in the forward path and a voltage reference plus opto-isolator in the feedback path. The application circuit shown in Figure 2 is an example of such a topology. The non-isolated application in Figure 1 makes use of a single inductor as the energy conversion element, and the feedback signal is directly supplied into the internal error amplifier. As can be seen from the application circuits, the isolated topology has an increased number of components, thus increasing the bill of materials (BOM) and system footprint.

To optimize cost and ease implementation, each application should be evaluated for its isolated or non-isolated requirements.

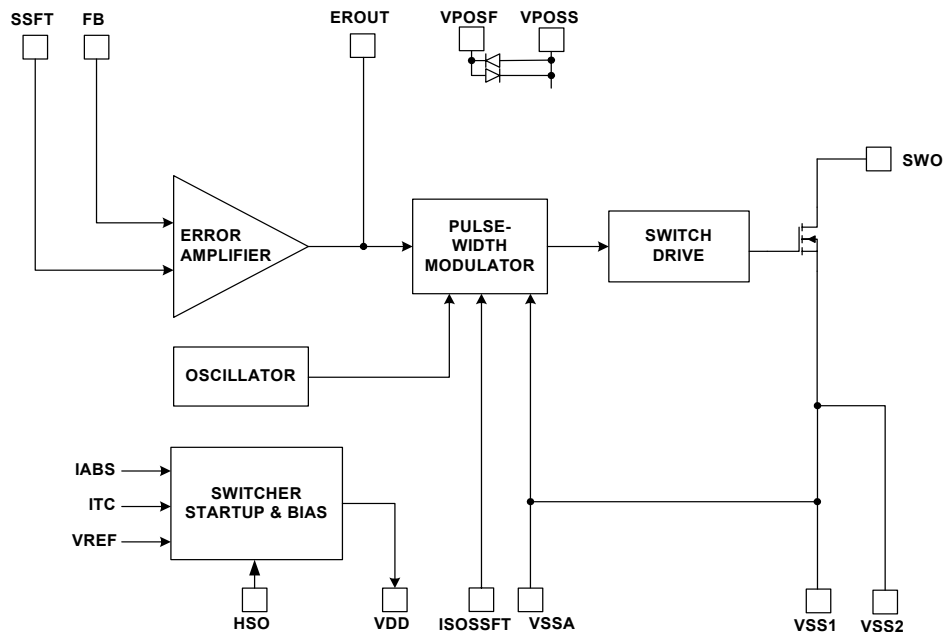

Figure 4. Switcher Block Diagram

### 3.3.1. Switcher Startup

The switching regulator is disabled until the hotswap interface has both identified itself to the PSE and charged the supply capacitor needed to filter the switching regulator's high-current transients. Once the supply capacitor is charged, the hotswap controller engages the internal bias currents and supplies used by the switcher. Additionally, the soft-start current begins to charge the external soft-start capacitor.

The voltage developed across the soft-start capacitor serves as the error amplifier's reference in the non-isolated application. Ramping this voltage slowly allows the switching regulator to bring up the regulated output voltage in a controlled manner. Controlling the initial startup of the regulated voltage restrains power dissipation in the switching FET and prevents overshoot and ringing in the output supply voltage.

In the isolated mode, a capacitor connected between pins ISOSSFT and VSSA slowly ramps the duty cycle clamp in the PWM circuit. Tie this pin to VDD if not used.

### 3.3.2. Switching Regulator Operation

The switching regulator of the Si3400 and Si3401 is constant-frequency, pulse-width-modulated (PWM), and controller integrated with switching power FETs optimized for the output power range defined by the 802.3 specification.

Once the hotswap interface has ensured proper turn-on of the switching regulator controller, the switcher is fully operational. An internal free-running oscillator and internal precision voltage reference are fed into the pulse-width modulator. The output of the error amplifier (either internal for non-isolated applications or external for isolated applications) is also routed into the PWM and determines the slicing of the oscillator.

The PWM controls the switching FET drive circuitry. A significant advantage of integrating the switching power FET onto the same monolithic IC as the switching regulator controller is the ability to precisely adjust the drive strength and timing to the FET's sizable gate, resulting in high regulator efficiency. Furthermore, current-limiting circuitry prevents the switching FET from sinking too much current, dissipating too much power, and becoming damaged. Thermal overload protection provides a secondary level of protection.

The flexibility of the Si3400 and Si3401's switching regulator allows the system designer to realize either the isolated or non-isolated application circuitry using a single device. In operation, the integration of the switching FET allows tighter control and more efficient operation than a general-purpose switching regulator coupled with a general-purpose external FET.

### 3.3.3. Flyback Snubber

Extremely high voltages can be generated by the inductive kick associated with the leakage inductance of the primary side of the flyback transformer used in isolated applications.

Refer to "AN296: Using the Si3400/01 PoE PD Controller in Isolated and Non-Isolated Designs" for more information on the snubber.

## 4. Pin Descriptions

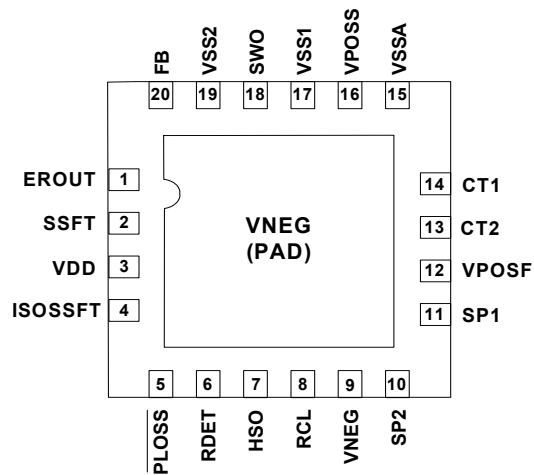

**Table 11. Si3400 and Si3401 Pin Descriptions (Top View)**

Pin#	Name	Description
1	EROUT	Error-amplifier output and PWM input; directly connected to opto-coupler in isolated application.
2	SSFT	Soft-start output pin ramps voltage across external soft-start capacitor to allow switcher to ramp output slowly.
3	VDD	5 V supply rail for switcher; provides drive for opto-coupler.
4	ISOSSFT	Isolated mode soft start enable input. Tie to VDD for non-isolated applications. Connect a 0.1 $\mu\text{F}$ capacitor between this pin and VSSA for isolated applications.
5	$\overline{\text{PLOSS}}$	Early power loss indicator; open drain output is pulled to VPOS when VPORT is applied.
6	RDET	Input pin for external precision detection resistor; also used for establishing absolute current reference.
7	HSO	Hotswap switch output; connects to VNEG through hotswap switch.
8	RCL	Input pin for external precision classification resistor; float if optional RCLASS is unused.
9, Pad	VNEG	Rectified high-voltage supply, negative rail. Must be connected to thermal PAD node (VNEG) on package bottom. This thermal pad must be connected to VNEG (pin #9) as well as a 2 in <sup>2</sup> heat spreader plane using a minimum of nine thermal vias.
10	SP2	High-voltage supply input from spare pair; polarity-insensitive.
11	SP1	High-voltage supply input from spare pair; polarity-insensitive.
12	VPOSF	Rectified high-voltage supply, positive rail (force node)
13	CT2	High-voltage supply input from center tap of Ethernet transformer; polarity-insensitive.
14	CT1	High-voltage supply input from center tap of Ethernet transformer; polarity-insensitive.
15	VSSA	Analog ground.
16	VPOSS	Rectified high-voltage supply, positive rail sense node.
17	VSS1	Negative supply rail for switcher; externally tied to HSO.
18	SWO	Switching transistor output; drain of switching N-FET.
19	VSS2	Negative supply rail for switcher; externally tied to HSO.
20	FB	Regulated feedback input in non-isolated application.

# Si3400/Si3401

## 5. Package Outline

Figure 5 illustrates the package details for the Si3400 and Si3401. Table 12 lists the values for the dimensions shown in the illustration.

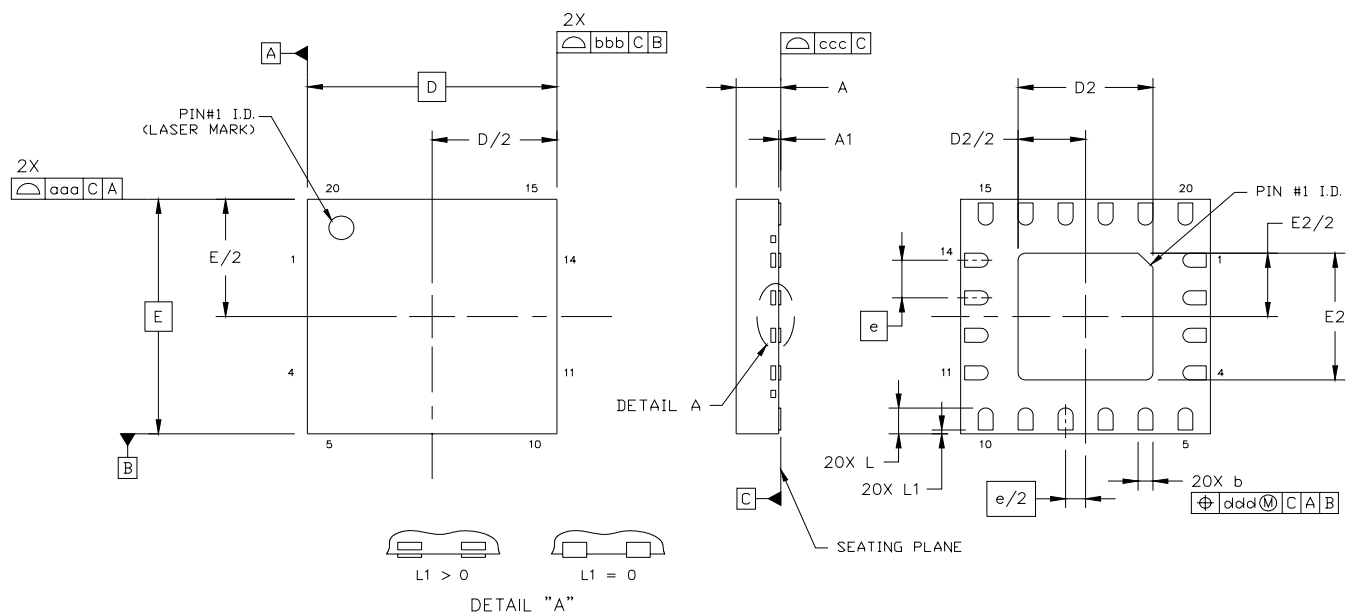

**Figure 5. 20-Lead Quad Flat No-Lead Package (QFN)**

**Table 12. Package Dimensions**

Dimension	Min	Nom	Max
A	0.80	0.85	0.90
A1	0.00	0.02	0.05
b	0.25	0.30	0.35
D	5.00 BSC.		
D2	2.60	2.70	2.80
e	0.80 BSC.		
E	5.00 BSC.		
E2	2.60	2.70	2.80
L	0.50	0.55	0.60
L1	0.00	—	0.10
aaa	—	—	0.10
bbb	—	—	0.10
ccc	—	—	0.08
ddd	—	—	0.10

**Notes:**

1. All dimensions shown are in millimeters (mm) unless otherwise noted.
2. Dimensioning and tolerancing per ANSI Y14.5M-1994.
3. This drawing conforms to the JEDEC Solid State Outline MO-220, Variation VHHB-1.

## 6. Ordering Guide

Part Number <sup>1,2</sup>	Package	Temp Range	Recommended Maximum Output Power <sup>3</sup>
Si3400-X-GM	20-pin QFN, Pb-free; RoHS compliant	-40 to 85 °C	≤ 10 W
Si3401-X-GM	20-pin QFN, Pb-free; RoHS compliant	-40 to 85 °C	14 to 16 W

**Notes:**

1. "X" denotes product revision.
2. Add an "R" at the end of the part number to denote tape and reel option.
3. Refer to "AN313: Using the Si3400/01 in High Power Applications" and "AN314: Power Combining Circuit for PoE for up to 18.5 W Output" for more information about using the Si3400 and Si3401 in higher power applications.

## DOCUMENT CHANGE LIST

### Revision 0.3 to Revision 0.4

- Updated Figure 2 on page 9.
  - R9 now correctly connected to VNEG; RIMAX now connects to VDD.
- Added Table 6, “Package Thermal Characteristics,” on page 7.
- Updated Figure 3 on page 10.
- Updated Table 4 on page 6.
  - Updated switcher frequency specification to 350 kHz.
- Added “pad” notes to VNEG pin under Description section in Table 11 on page 15.
- Updated Table 7, “Component Listing—Class 0 with 5 V Output,” on page 8 and Table 8, “Components—Class 1 with Isolated 5.0 V Output,” on page 9.
  - Updated recommended BOMs.

### Revision 0.4 to Revision 0.5

- Updated Table 4 on page 6.
  - Updated test condition for VDD current.
  - Updated minimum value of switcher FET on resistance.
- Updated Table 8 on page 9 and Table 10 on page 12.
  - Updated Rclass information.
- Updated “5. Package Outline” and Table 12, “Package Dimensions,” on page 16.
  - Replaced package drawing and dimensions table.

### Revision 0.5 to Revision 0.6

- Added Si3401.
- Updated Figure 1 on page 8.
- Updated Table 7 on page 8.
- Updated “6. Ordering Guide” on page 17.

### Revision 0.6 to Revision 0.7

- Added VSSA pin throughout document for product revisions beginning with Rev D.
- Updated Table 2 specs (for ESD).
- Updated Table 4 specs (for current limits).
- Updated Table 5 specs (for power dissipation).
- Updated Figure 1 and Table 7.
- Updated Figure 2 and Table 8.
- Updated Figure 4 and Table 11.

### Revision 0.7 to Revision 0.8

- ISOSSFT (pin 4) added throughout document.
- Updated Figures 1 and 2 for addition of ISOSSFT pin. Function available on Revision E and higher.

### Revision 0.8 to Revision 0.9

- Updated throughout document to support Revision E.
- Added Regulated Output Voltage Tolerance specification to Table 4, for non-isolated applications only.
- Updated Figure 1, Figure 2, and Table 7 for Rev. E BOM changes.
- Nominal class resistor values updated for Rev. E in Table 10.

**NOTES:**

## CONTACT INFORMATION

### Silicon Laboratories Inc.

400 West Cesar Chavez  
Austin, TX 78701  
Tel: 1+(512) 416-8500  
Fax: 1+(512) 416-9669  
Toll Free: 1+(877) 444-3032  
Email: [PoEinfo@silabs.com](mailto:PoEinfo@silabs.com)  
Internet: [www.silabs.com](http://www.silabs.com)



The information in this document is believed to be accurate in all respects at the time of publication but is subject to change without notice. Silicon Laboratories assumes no responsibility for errors and omissions, and disclaims responsibility for any consequences resulting from the use of information included herein. Additionally, Silicon Laboratories assumes no responsibility for the functioning of undescribed features or parameters. Silicon Laboratories reserves the right to make changes without further notice. Silicon Laboratories makes no warranty, representation or guarantee regarding the suitability of its products for any particular purpose, nor does Silicon Laboratories assume any liability arising out of the application or use of any product or circuit, and specifically disclaims any and all liability, including without limitation consequential or incidental damages. Silicon Laboratories products are not designed, intended, or authorized for use in applications intended to support or sustain life, or for any other application in which the failure of the Silicon Laboratories product could create a situation where personal injury or death may occur. Should Buyer purchase or use Silicon Laboratories products for any such unintended or unauthorized application, Buyer shall indemnify and hold Silicon Laboratories harmless against all claims and damages.

Silicon Laboratories and Silicon Labs are trademarks of Silicon Laboratories Inc.

Other products or brandnames mentioned herein are trademarks or registered trademarks of their respective holders.

## Looking for pricing, stock, or lifecycle information?

Click below to explore more details on WIN SOURCE:

-  [View SI3401-D-GM on WIN SOURCE](#)
-  [Silicon Labs Information](#)

## Optimize Your Supply Chain with WIN SOURCE Solutions

-  Global Sourcing Solution
-  Obsolete Management
-  Cost Control Management
-  Shortage Management
-  Alternative Solution
-  Excess Inventory Management